

EK-UC60F

UNDERCOUNTER FREEZER



FEATURES

NEMA 5-15P



- CFC free refrigerant and foam insulation
- Electronic thermostat and digital LED temperature display for accurate control and easy reading
- Easy to mount 2.5" casters (lockable in front) are standard with all units
- Self-closing doors that remain open at 90 degrees
- Magnetic gasket can be replaced without any tools
- Adjustable, heavy-duty epoxy coated wire shelves (one per door)
- Stainless steel framework construction
- Auto defrosting and auto evaporation of condensation water
- Freezer door frames have integral factory installed heating element to eliminate condensation
- Interior: 304 stainless steel
- Exterior: 430 stainless steel
- R-290 Natural refrigerant
- Temperature: 0 to -10°F / -17 to -23 °C
- Electrical: 115/60/1 with NEMA 5-15P, 10ft cord

Specifications subject to change without notice

WARRANTY: One (1) Year Parts & Labor. Warranty commences on date of sale.



SIDE

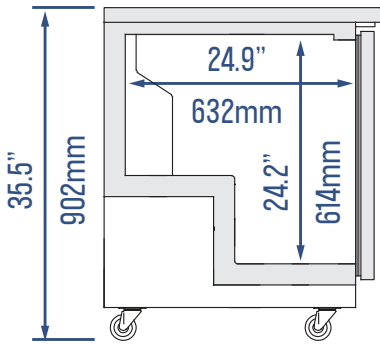

FRONT

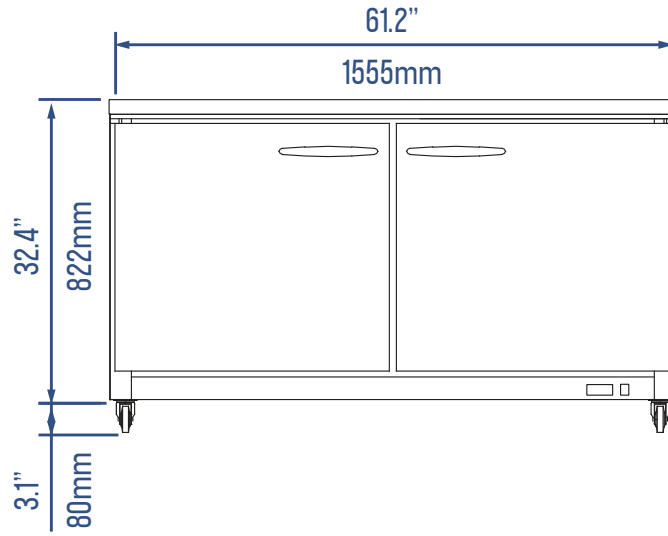

TOP

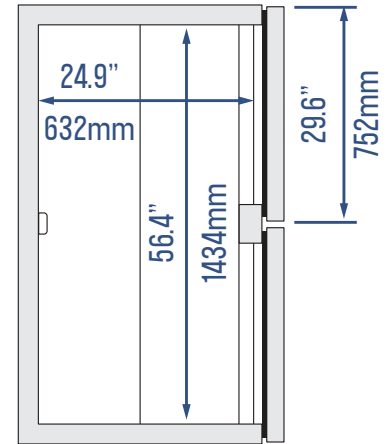

TECHNICAL SPECIFICATIONS

Model	Doors	Exterior Dimensions W x D x H	Interior Dimensions W x D x H	Amps	HP	Shipping Weight
EK-UC60F	2	61.2 x 29.9 x 35.5 in 1555 x 760 x 902 mm	56.4 x 24.9 x 24.2 in 1434 x 632 x 614 mm	5A	1/2	353 lbs 160 kg