

➤ Instructions

Thule Tour Rack 100090

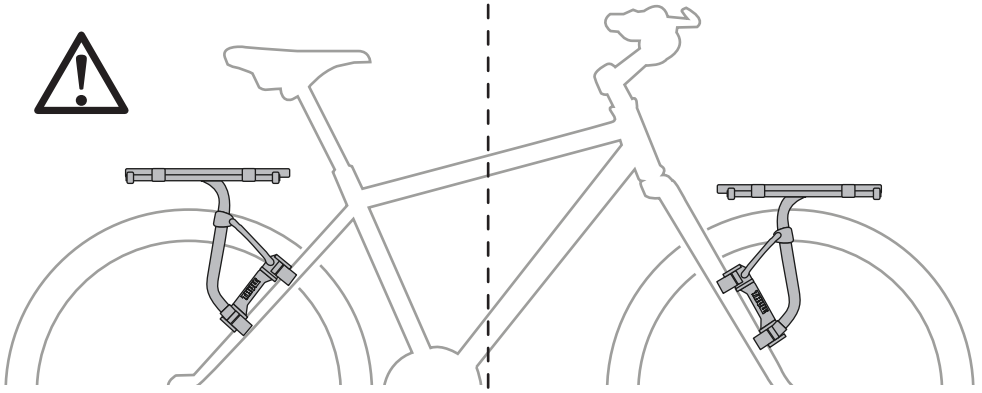



Max.
25 lbs
11.3 kg

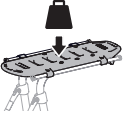

Max.
15.5 lbs
7 kg

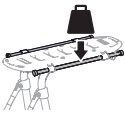

Max.
25 lbs
11.3 kg



Max.
22 lbs
10 kg



Max.
13.75 lbs
6.2 kg

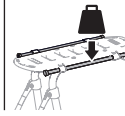

Max.
22 lbs
10 kg



Not ok



Not ok



Not ok



Not ok

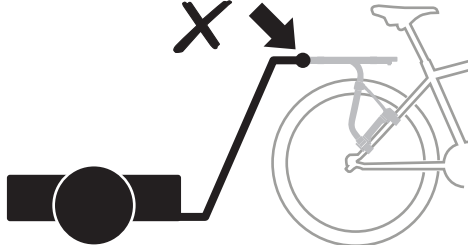



- EN** Do not make any modifications to the rack. Do not use the rack if it is damaged or becomes loose.
- DE** Nehmen Sie keine Veränderungen an dem Gepäckträger vor. Verwenden Sie den Gepäckträger nicht, wenn er beschädigt ist oder nicht fest sitzt.
- FR** N'apportez pas de modifications au porte-bagages. N'utilisez pas le porte-bagages s'il est endommagé ou mal fixé.
- NL** Breng geen aanpassingen aan op deze bagagedrager. Gebruik de bagagedrager niet als hij beschadigd is of los gaat zitten.
- IT** Non apportare modifiche al portatutto. Non utilizzare il portatutto se danneggiato o se si allenta.
- ES** No haga ninguna modificación en el soporte. No lo utilice si esta dañado o se ha aflojado.
- PT** Não efectue quaisquer modificações ao suporte. Não utilize o suporte se este estiver danificado ou solto.
- SV** Gör inte några modifieringar på hållaren. Använd inte hållaren om den har blivit skadad eller sitter löst.
- DK** Undlad at foretage ændringer på bagagebæreren. Undlad at bruge bagagebæreren, hvis den er beskadiget eller sidder løst.
- NO** Ikke gjør endringer på stativet. Ikke bruk stativet hvis det er skadet eller er løst.
- FI** Älä tee muutoksia telineeseen. Älä käytä telinettä, jos se on vaurioitunut tai irronnut.
- ET** Hoidikut ei tohi mingil viisil modifitseerida. Ärge kasutage hoidikut, kui see on kahjustatud või ei ole korralikult kinnitatud.
- LV** Neveikt bagāžniekam nekādas izmaiņas. Nelietot bagāžnieku, ja tas ir bojāts vai kļūvis vaļīgs.
- LT** Nekeiskite bagažinės konstrukcijos. Nenaudokite bagažinės, jei ji pažeista arba atsilaisvinusi.
- PL** Nie należy modyfikować bagażnika w żaden sposób. Nie używać bagażnika, jeśli jest uszkodzony lub obłuzowany.
- RU** Не вносите изменений в конструкцию багажника. Не используйте его, если он поврежден или плохо закреплен.
- UK** Не змінюйте конструкцію багажника. Не використовуйте багажник, якщо він пошкоджений або погано закріплений.
- BG** Не правете никакви промени по релсите. Не използвайте релсите, ако са повредени или разхlabени.
- CS** Nosič nijak neupravujte. Nosič nepoužívejte, je-li poškozen nebo se uvolní.
- SK** Nevykonávajte žiadne úpravy nosiča. Nepoužívajte nosič, ak je poškodený alebo zle upevnený.
- SL** Ne spreminjajte prtlačnika. Če je prtlačnik poškodovan ali se razhlaja, ga ne uporabljajte.
- HR/BIH** Ne radite nikakve preinake na nosaču. Nemojte koristiti nosač, ako je oštećen ili nije dobro pričvršćen.
- RO** Nu aduceți niciun fel de modificări portbagajului. Nu utilizați portbagajul dacă este deteriorat sau dacă sistemul de fixare începe să se slăbească.
- HU** Ne végezzen módosításokat a csomagtartón. Ne használja a csomagtartót, amennyiben az megsérült, vagy kilazult.
- EL** Μην τροποποιείτε με κανέναν τρόπο τη σχάρα. Μην χρησιμοποιείτε τη σχάρα, αν έχει υποστεί ζημιά ή έχει χαλαρώσει.
- TR** Taşıma sisteminde herhangi bir deęişiklik yapmayın. Hasarlıya veya gevşemişse taşıma sisteminizi kullanmayın.
- HE** אין לערוך שינויים כלשהם במתלה. אין להשתמש במתלה אם הוא פגום או רופף.
- AR** لا تجري أي تعديلات على الحمل. لا تستخدم الحمل إذا كان نالفاً أو أصبح مرتخياً.
- ZH** 不要对此车架进行任何改装。如果车架损坏或松动，请勿使用机架。
- JA** ラックを改造しないでください。ラックに破損またはグラつきがある場合は使用しないでください。
- KO** 랙을 개조하지 마십시오. 랙이 손상 또는 느슨해진 경우 사용하지 마십시오.
- TH** อย่าดัดแปลงแก๊วไรค์ อย่าใช้แร็คถ้าแร็คได้รับความเสียหายหรือหลวม

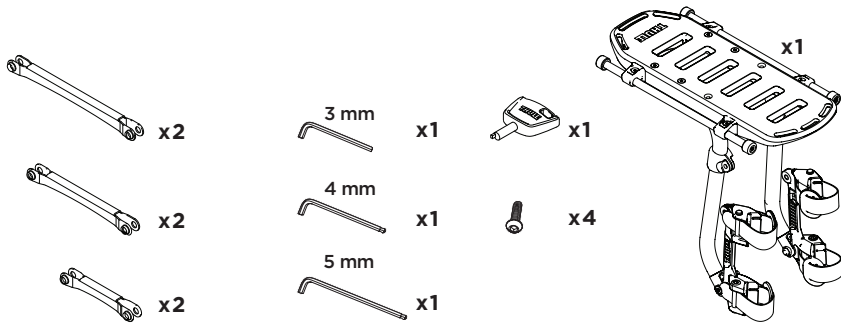

1 (x4)

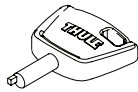

A

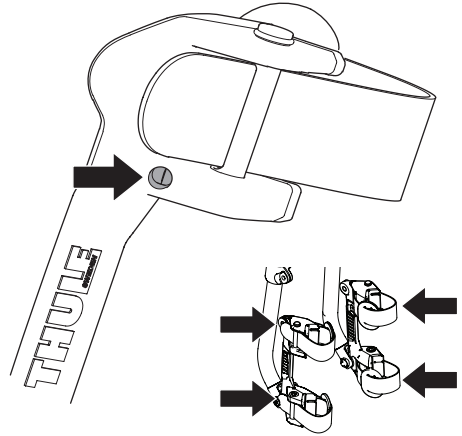
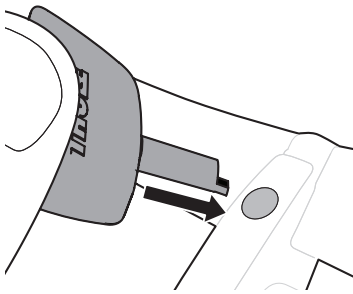

B

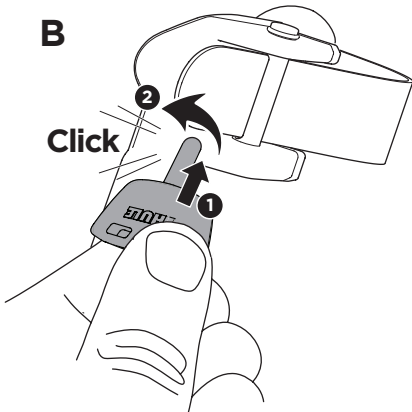

C

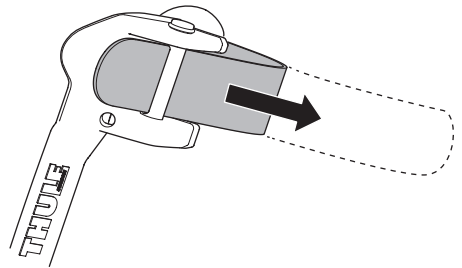

2

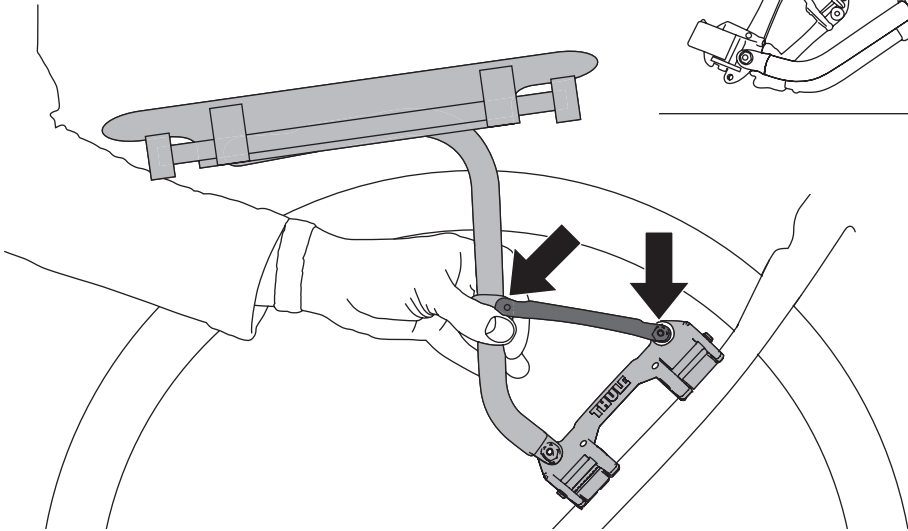
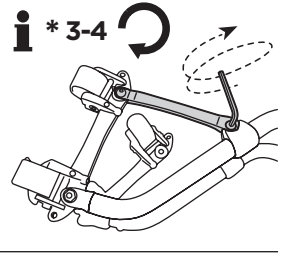
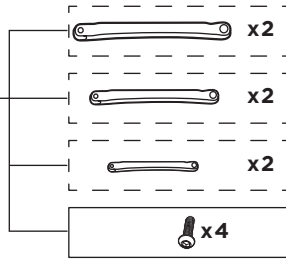
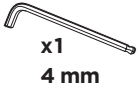

ok
✓

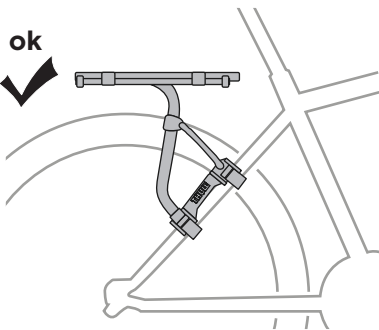

ok
✓

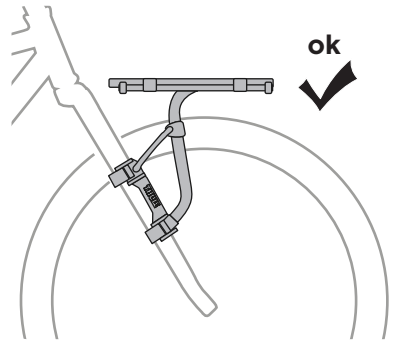

3

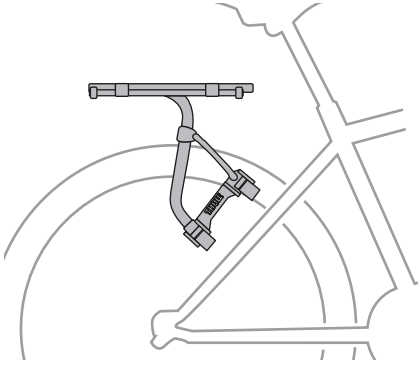
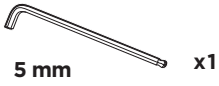

Not ok

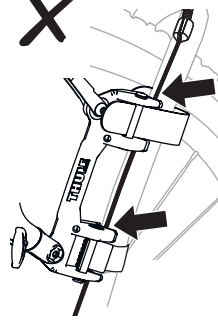

ok

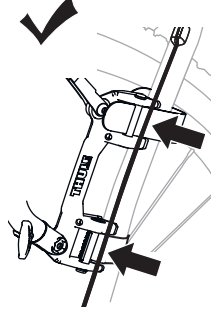

B

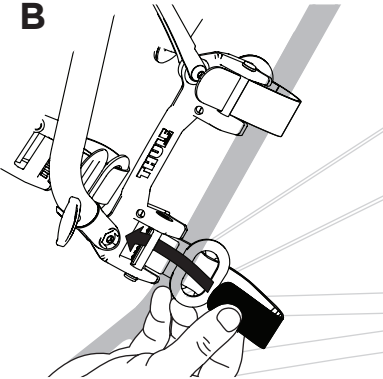

C

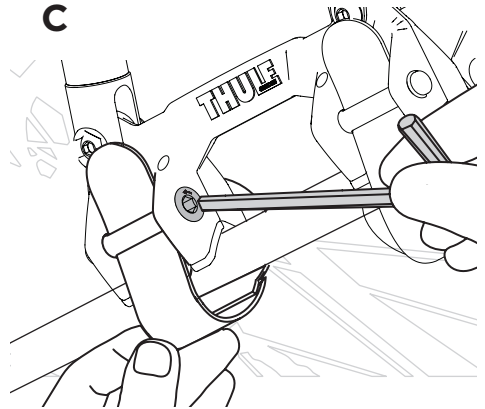

D

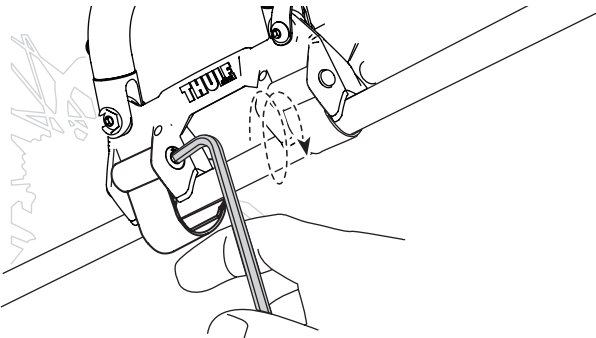

x4



4



A

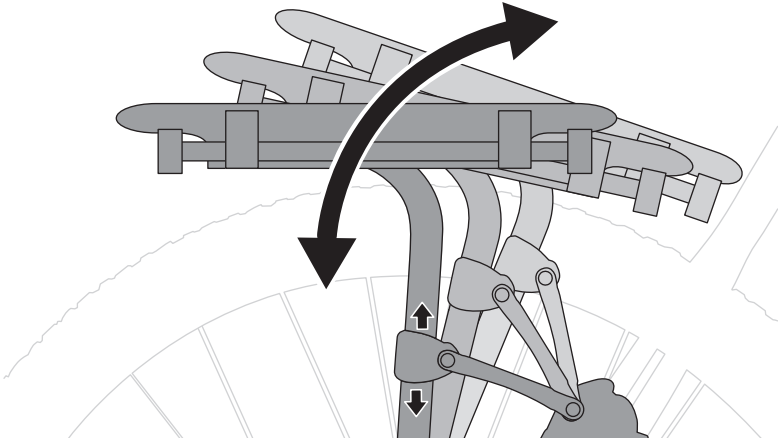

B

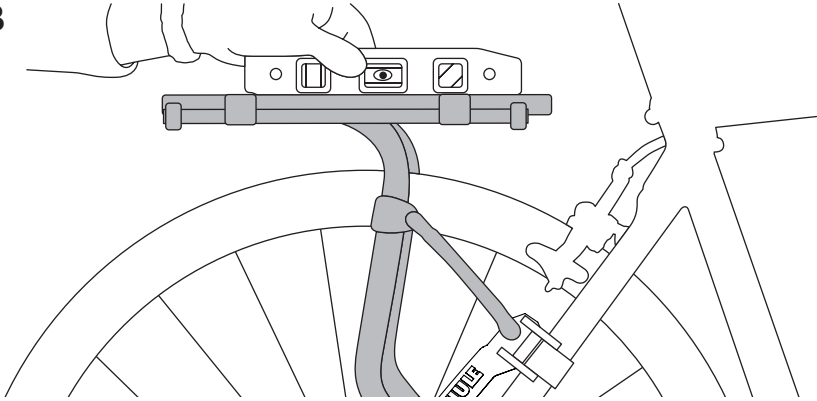

C

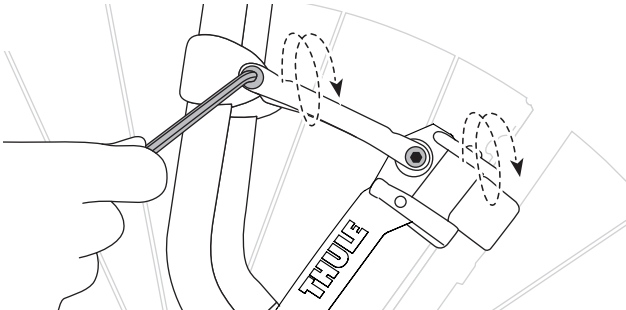

x4



5

3 mm x1

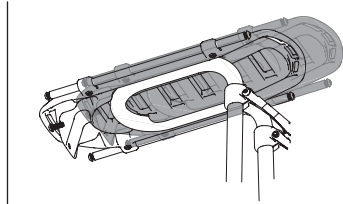
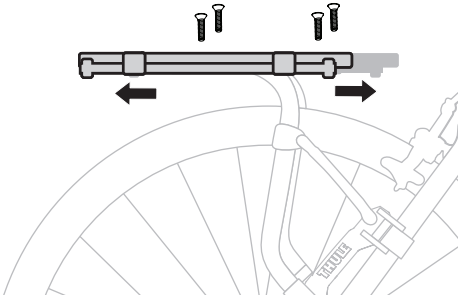

A

i (x4)

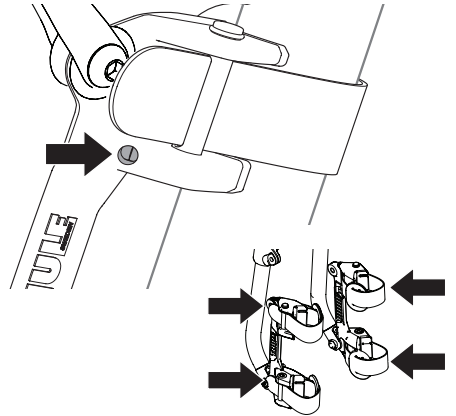
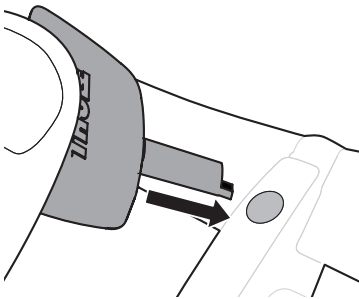
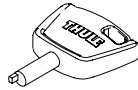

B

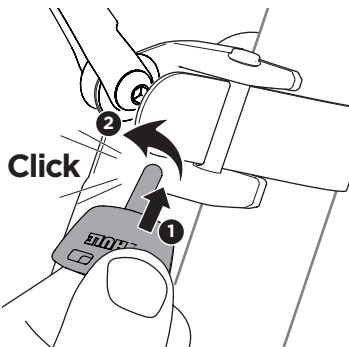

C

