

# Grandma's Hot Box

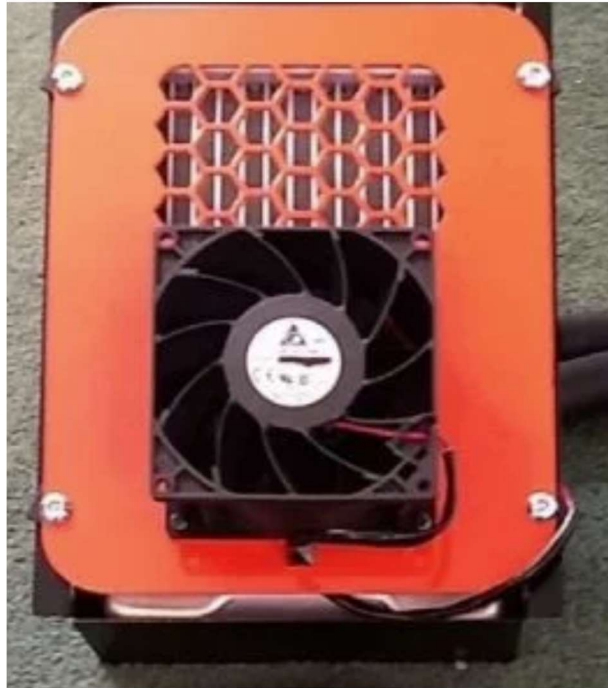

- 1 x metal box
- 1 x face plate
- 1 x fan can be purchase on our website
- 1 x switch can be purchase on our website
- 4 x m6 clip nuts
- 4 x m6 x 25mm screws
- 2 x heater hoses gates 28467
- 6 x hose clamps 1.5"
- 12ft to 15ft of 20ga wire
- 2 x reducer nipples
- 4 x fan screws
- 1x Heater core [Spectra 94575 Heater Core](#)

1. Remove seats
2. Lift the rear access panel upward and towards front of vehicle to remove.

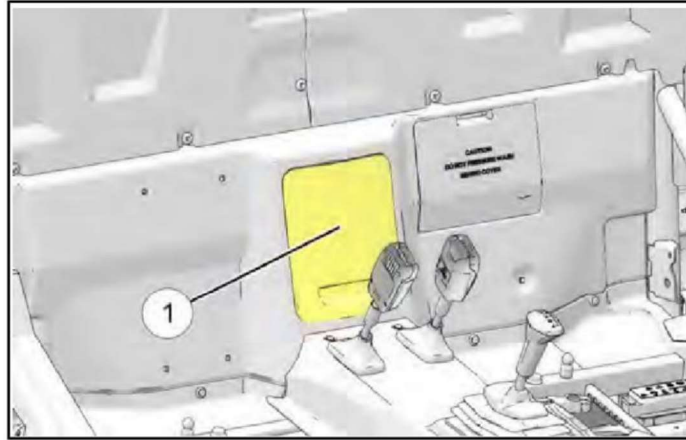

3. Place the face plate into the opening and drill out the mounting holes in the plastic as in the picture drill closest to the radius

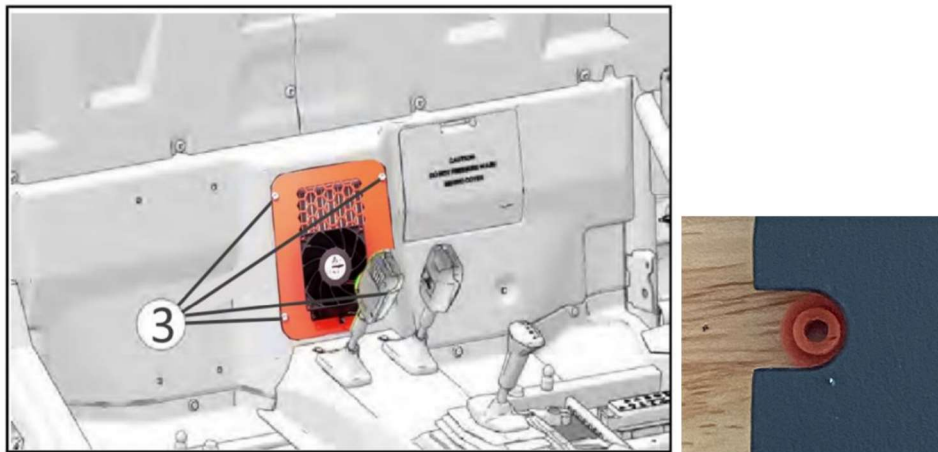

4. Insert Weather Stripping into the bottom of box as shown in picture below start with the piece where the 2 oval cutouts place just under then the sides then the bottom make sure they are tight to each other this keeps outside air and water out. Ee used a closed foam weather stripping we got form Lowes **M-D 10-ft x 3/4-in x 1/2-in Gray PVC Foam Window Weatherstrip**  
Item #66682  
Model #02311

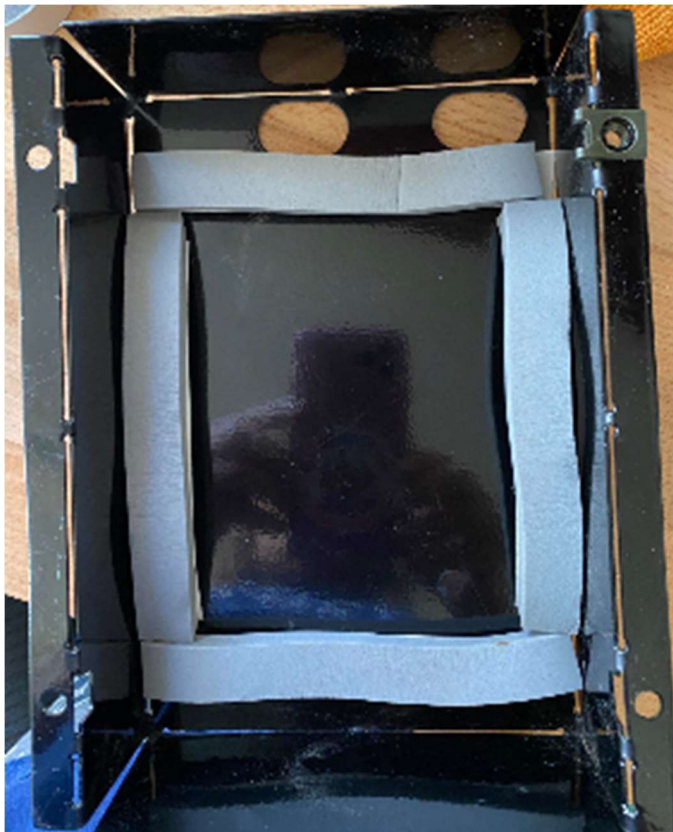
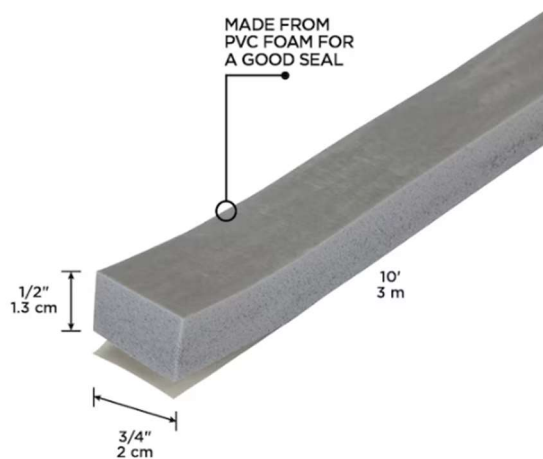

Insert heater core into box [Spectra 94575 Heater Core](#)

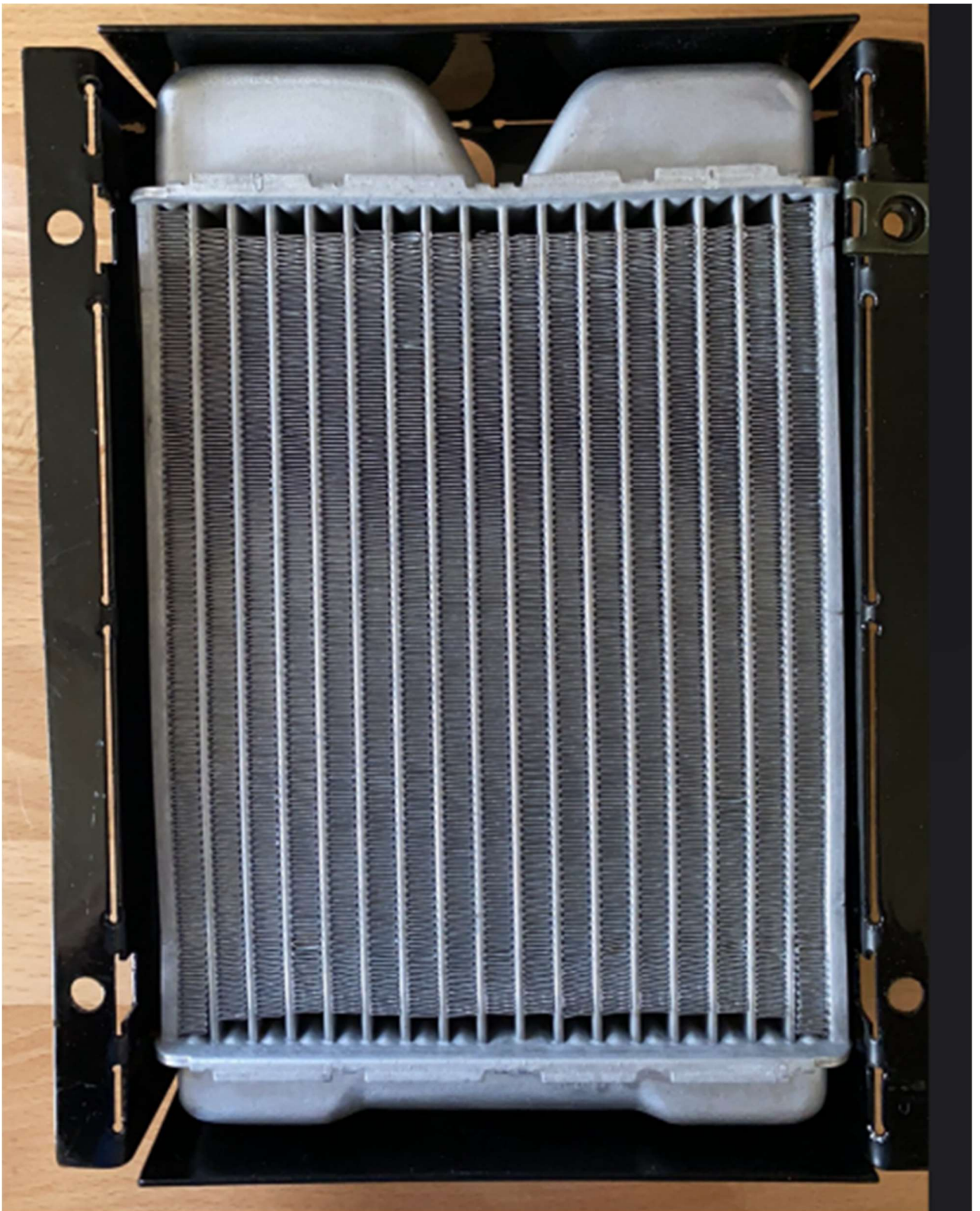



5. Slip clip nuts over holes from inside out. These clip nuts used are threaded M6x1 Purchase on Amazon M6-1.0 Screw Size for GM 11503714

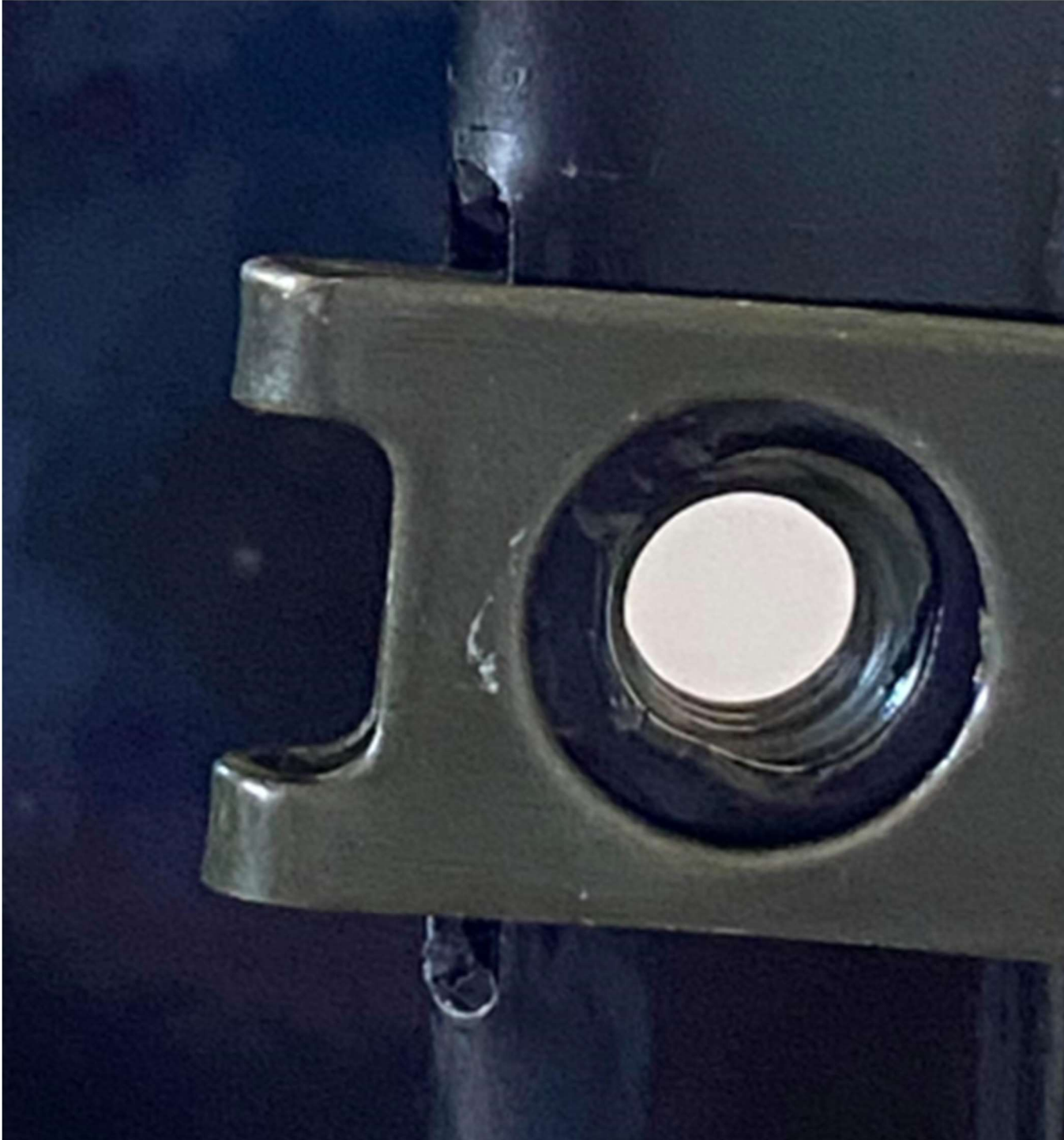

6. Installing the 2 hoses onto the heater core angles to the right is shown you may need to shorten hoses depending on where you cut into the oil cooler line.

GATES heater hose 28467 you can purchase these hoses at any auto parts store

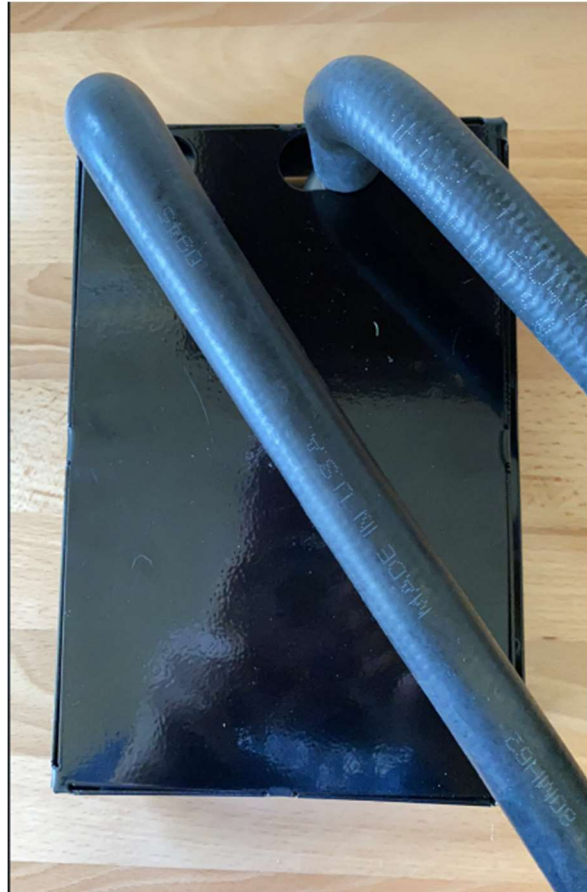

Place hose clamps on and tighten just so you can still rotate hoses.

7. Insert reducer nipples into hoses and tighten down hose clamps.  
5/8" to 1/2" can also be purchased at auto part store

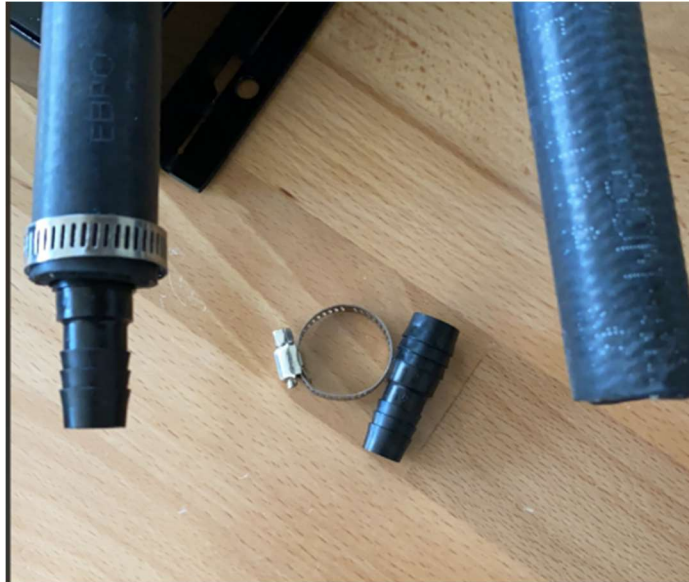

8. Now you can fill heater core with antifreeze and cap off the ends with plugs that are included.  
I used an 3/8 rubber cap on the 1\2" side to hold the Anti-Freeze in the system  
if you do it this way you will only lose a table spoon of liquid

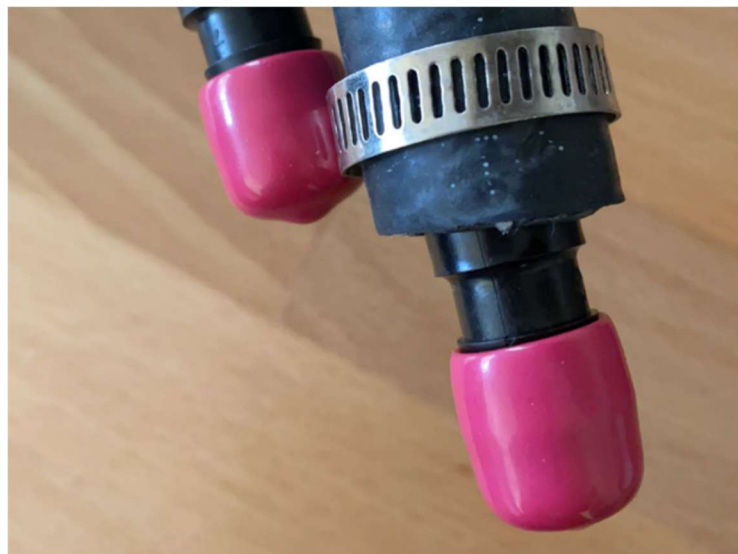

9. Make sure you place foam around fan has no gaps

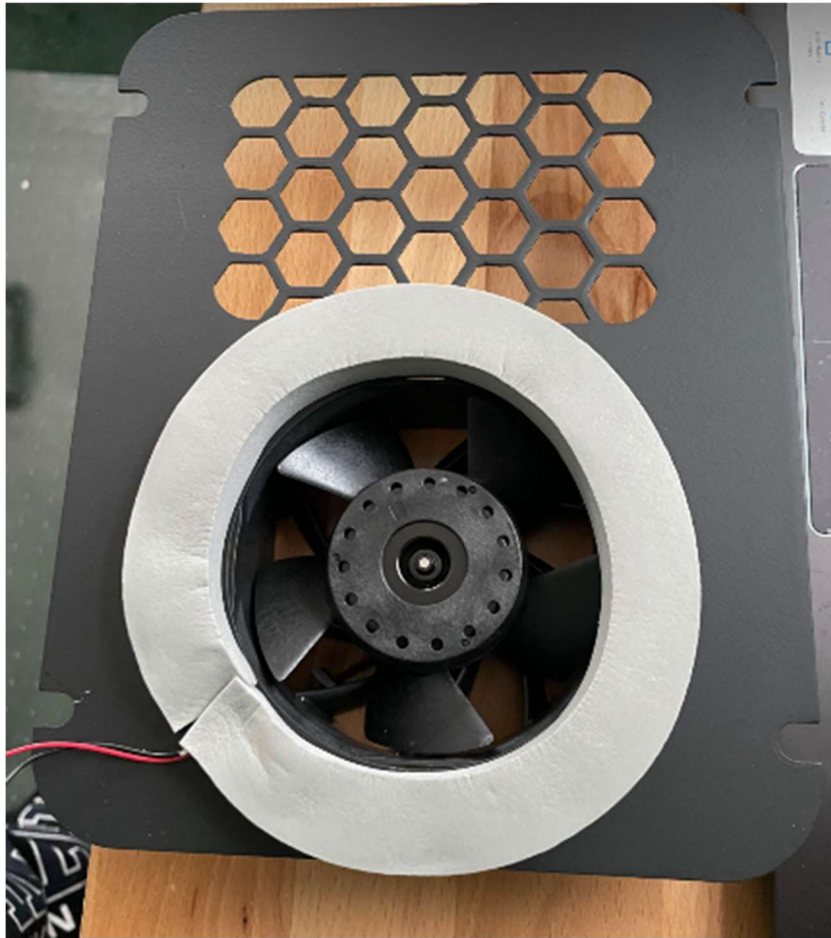

If we do have some fans left over they will be on sale on the website until they are gone.



10. It is now time to install the heater into the access hole there are 2 ways to do this get a helper to hold the box and help line up the holes from the back of the machine or take the top plastic above the access hole off (if doing this yourself you will have to take this piece off)

Remove the seven T-40 Torx screws ② on the cab side of cargo box. ""for self install""

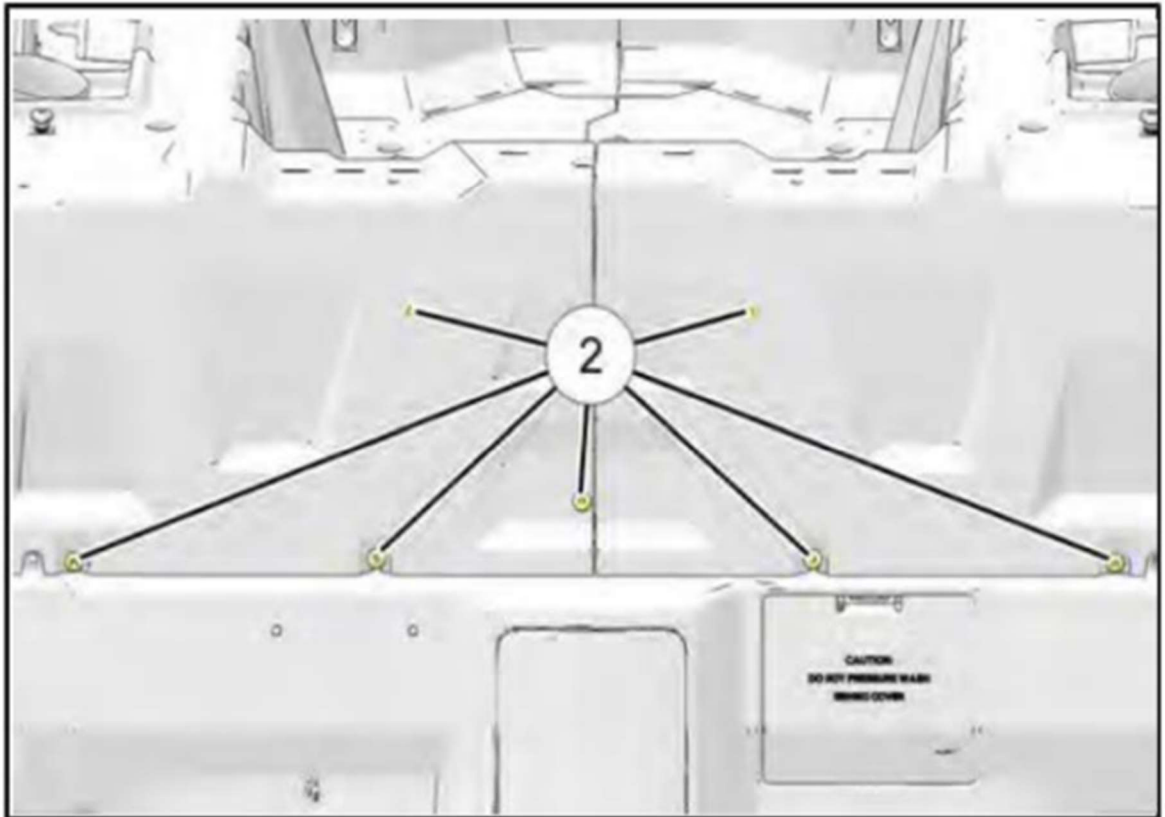

There may be more screws than what is shown depending on what year your machine is

11. You are going to want to pinch off the oil cooler lines with needle nose vice grips about 2" gap between them this will keep the loss of fluids and keeps the mess down. Place one 3" from the top of the hose and the other 2" below the first one.



12. Spilt hose between the 2 vice grips (on the hose closest to the outside of the machine on the passenger side) and install heater core hoses to each end Trim hoses in kit to fit so there is no excess.

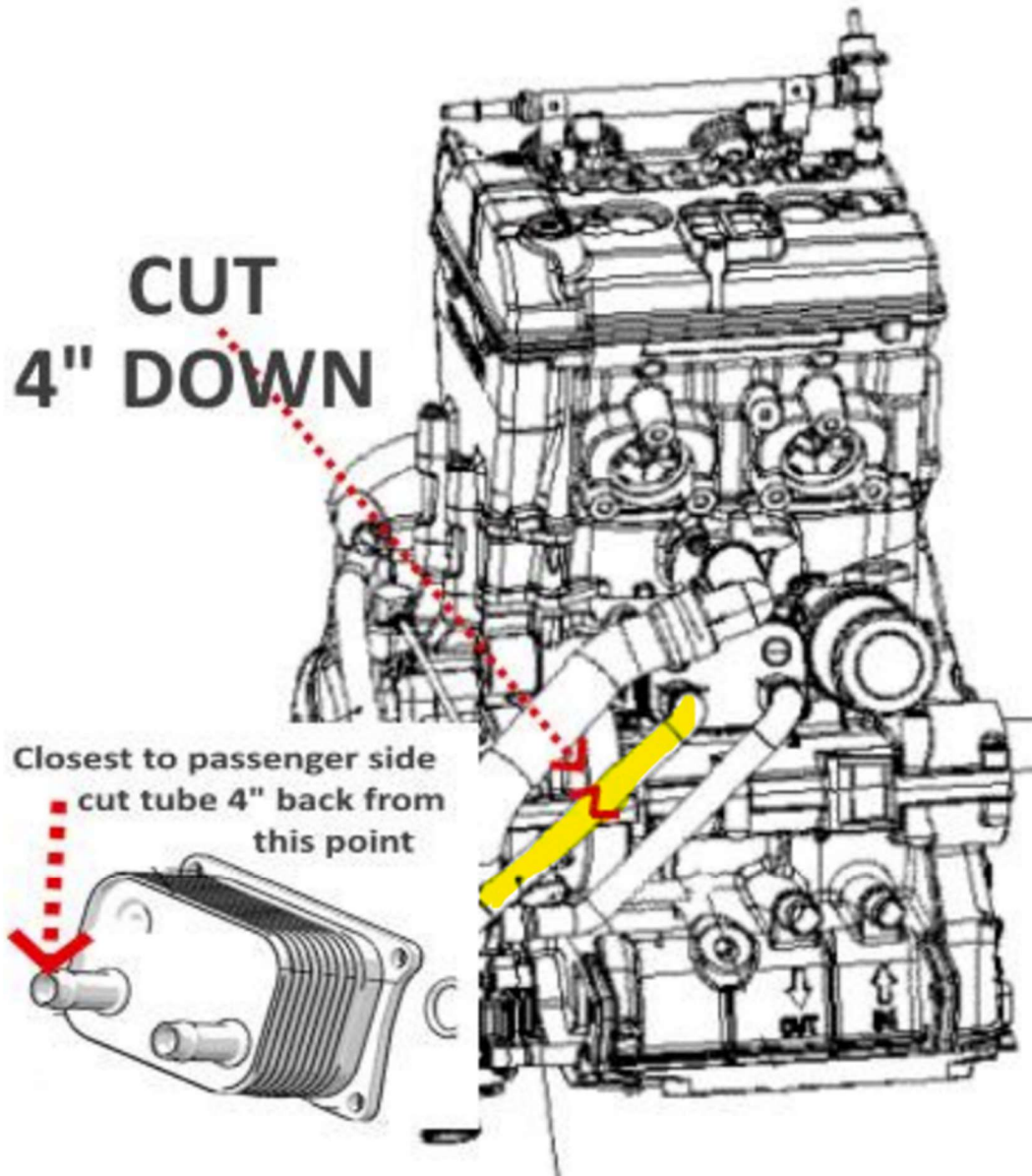

13. Once you have each hose connected tighten down the hose clamps

14. Now you can wire this system up you're going to need to take the tunnel off so you can run the wires under and up to the dash

