

Infra-red Gas Heaters



MANUAL for INSTALLATION, RUNNING and MAINTENANCE

Models: UFO EB /08 and UFO M /08

Version "UFO /08"

SIABS S.r.l. – ITALY

viale Del Lavoro, 7
20010 – Casorezzo (MILAN)

Phone: +39 02 90384081

Email: commerciale@siabs.it

Web: www.siabs.com

CONTENT

General instruction	3
For Your safety	4
Warranty terms	4
Labels	5
. plate with technical data	5
. packing label	5
Technical data	6
. appliances version UFO EB/08 (electronic start-up, two-stages)	6
. appliances version UFO M/08 (manual start-up, on-off)	6
Installation	7 to 15
. ventilation	7
. positioning	8
. handling	8
. MINIMUM height of installation (for people comfort)	9
. MINIMUM distances (from flammable surfaces)	9
. assembling	10
. connection to GAS supply	11
. connection to ELECTRIC feeding	12
. SIT control unit, TWO-STAGE version	13 and 14
. SIT control unit, wiring diagram, TWO-STAGE version	15
Put in operation and First Start-up	16 to 19
. appliances version UFO EB/08 (electronic start-up, two-stages)	17 and 18
. appliances version UFO M/08 (manual start-up, on-off)	19
Maintenance and Annual Check	20 to 22
. ordinary maintenance (suggestions)	20
. nozzle replacement	21
. trouble shooting	22
. serial number (bars code)	22
SPARE-PARTS, suggested list	22
Decommissioning and disposal (norms for user)	23
CE certificate	24
Service sheet	25



GENERAL INSTRUCTIONS for INSTALLER, USER and MAINTENANCE PERSONNEL

Thank you for your preference and trust granted! SIABS is pleased to have You among his Customers; our appliances are designed and manufactured to the most modern and rational processing systems and we do think that their use will be fully satisfactory.

To keep appliances perfectly working and safe, time passing, we invite you to **read and follow the instructions** of this handbook and **commit all installation and maintenance (ordinary and extraordinary) operations only to skilled personnel**, with specific technical skills in the field of components of heating, preferably to SIABS authorized Service Centre.

For the INSTALLER:

- **read carefully the warnings** in the manual **before performing any operation** as they provide important information concerning the safety of installation, use and the necessary maintenance operations to be performed
- this manual is integral and essential part of the product and **must be delivered to the user; retain it carefully for further consultations**
- **in case of non-compliance with the following instructions, the warranty covering the product(s) will be null and void**
- **BEFORE THE INSTALLATION**, verify that local gas distribution (type of gas and pressure) and appliance settings are compatible
- appliance must be **installed only in premises with adequate ventilation**
- installation should be done in **accordance with the Regulations in force** in the country of destination, to the state of art, following instructions by the Manufacturer
- **incorrect installation can cause damage** to people, animals and things; the Manufacturer doesn't accept any contractual and extra-contractual liability in tort and contract for damages caused by errors in installation and use
- use only original accessories and modification kits
- after you have removed all items from packing box, **make sure that all components have been included and their integrity**, in case of doubt not use the appliance and contact the Manufacturer; elements of packaging are potentially dangerous: therefore should not be left within the reach of children and must be disposed according to regulations in force
- before any cleaning or maintenance operation, **wait until the appliance is cold, disconnect it from the electricity supply and bring the fuel shut-off valve in the closed position**

For the USER and OWNER of the plant:

- this manual is integral and essential part of the product and **must be delivered to the user; retain it carefully for further consultations**
- **in case of non-compliance with the following instructions, the warranty covering the product(s) will be null and void**
- use only original accessories and modification kits
- in case of failure and/or malfunction of the appliance, turn it off refraining from any attempt to repair or direct intervention; **contact SIABS authorized Service Centre**
- when you decide to stop using the appliance, for **DISPOSAL or RESALE**, you will have to render harmless all parties which can be a source of potential danger; **the technical manual is integral and essential part of the product: it must be preserved and accompany the appliance in case of property change, so that it can be consulted by the new user and / or maintenance staff**

FOR YOUR SAFETY



In case of gas smell: DO NOT operate the heating plant, vent the ambient, DO NOT start apparatus or electric switches; contact the installer and gas supply company and follow scrupulously their instruction

IMPORTANT: appliances **MUST NOT be used in domestic environments.** This appliance will be devoted only to the use for which it was expressly provided, **all other uses will be considered improper and therefore dangerous.**

IMPORTANT: appliances **MUST NOT be used in ambient with flammable materials, liquids or vapours:** non-compliance with these requirements may be cause of death, injury to persons or damage to things.

Warranty

SIABS guarantees its products, whether installed by authorized personnel, for a period of 24 months from the invoice date. The warranty does not cover the components supplied by third parties, these are subject to the conditions of the original warranty.

The guarantee is only the free supply on Ex-Works basis, of parts with manufacturing or workmanship defects.

The guarantee does not cover problems due to carelessness, incorrect setting, misuse of the appliance or fortuitous accidents, and not dependent on imperfection processing or defective materials, and those due to dismantling or changes without prior authorization from SIABS.

The correct functioning of the appliances depends on a proper installation and start-up. Failure to comply with these rules immediately involves the decay of the guarantee, and therefore of responsibility by the manufacturer.

Plate label

On each unit you will find a plate with technical data – **do not remove** – placed on the cover of the gas group.

Apparatus type A1, gas category II 2H3B/P

		Този уред трябва да бъде инсталиран съгласно действащите норми и само в помещения, където е възможна вентилация и директно проветряване в съответствие с норматива EN 13410. Да се прочетат инструкциите преди да се инсталира или използва този уред.	
Телефон +39- 02-90384081 www.siabs.com - ИТАЛИЯ		PIN код 0694BS0965	
Модел	UFO EB/08	Предназначен за държава	BG
Версия	UFO	Година на производство	2013
Категория	II 2H3B/P	0694	
Преди всякаква интервенция или ремонт на уреда да се изключат подаването на газ и електрическото захранване			
Категория нагревател	: A1	Тип пlynу	G20
Напрежение	230 Volt	Полезна мощност Hs MAK / MIN	9.4 / 7.1 кВт
Честота	50 Hz	Полезна мощност Hi MAK / MIN	8.5 / 6.4 кВт
Електрическа мощност	24 Вт	Разход на газ MAK / MIN	0.90 / 0.68 м3/ч
Степен на защита	IP20	МАК захранващо налягане	50.0 мбар
Диаметър на дюзата	2.30 mm	Налягане на газа	20.0 мбар
Категория NOx	4	Налягане пред дюзата MAK / MIN	15.0 / 9.0 мбар
ЗАБРАНЕНО Е ИЗПОЛЗВАНЕТО НА УРЕДА В ЖИЛИЩНИ ПОМЕЩЕНИЯ			

Plate label (f.e.: appliance UFO E B/08, electronic start-up, version two-stages, G20 gas)

Essential features of the appliance are given on the packing label, outside on the packing box.

dal 1952 			
bruciatori & calore radiante		694	
www.siabs.com		+39_02_90384081	
Категория	II 2H3B/P	метан (G20) 20 mbar	
Предназначен за държава	BG		
Инфра червен нагревател :	UFO EB/08		
Версия :	UFO		
внимание :	Две нива на мощност		
Този уред трябва да бъде инсталиран съгласно действащите норми и само в помещения, където е възможна вентилация и директно проветряване в съответствие с норматива EN 13410. Да се прочетат инструкциите преди да се инсталира или използва този уред.			

TECHNICAL DATA

Appliance model		UFO EB /08	UFO M /08
Electric feeding		230 Volt - 1phase - 50 Hz	NO
MAX feeding pressure	(mbar)	50,0	50,0
Gas group	nr.	1	1
Gas connection		1 x 3/8"	1 x 3/8"
Absorbed power	(Watt)	24	NO
NOx class		4	4
Weight	(kg)	10	10
Cover diameter	(mm)	800	800
Height	(mm)	650	650
Remote control	(mm)	option	option
GAS G20			
Heat input MAX (Hs)	(kW)	9,4	9,4
Heat input MAX (Hi)	(kW)	8,5	8,5
Heat input MIN (Hs)	(kW)	7,1	-
Heat input MIN (Hi)	(kW)	6,4	-
GAS supply pressure	(mbar)	20,0	20,0
NOZZLE pressure MAX	(mbar)	15,0	15,0
NOZZLE pressure MIN	(mbar)	9,0	-
Gas consumption MAX	(Sm ³ /h)	0,90	0,9
Gas consumption MIN	(Sm ³ /h)	0,68	-
Nozzle diameter	(mm)	2,30	2,3
GAS G30			
Heat input MAX (Hs)	(kW)	10,8	10,8
Heat input MAX (Hi)	(kW)	10,0	10,0
Heat input MIN (Hs)	(kW)	8,1	-
Heat input MIN (Hi)	(kW)	7,5	-
GAS supply pressure	(mbar)	30,0	20,0
NOZZLE pressure MAX	(mbar)	27,7	27,7
NOZZLE pressure MIN	(mbar)	15,5	-
Gas consumption MAX	(kg/h)	0,79	0,8
Gas consumption MIN	(kg/h)	0,59	-
Nozzle diameter	(mm)	1,60	1,6
GAS G31			
Heat input MAX (Hs)	(kW)	10,9	10,8
Heat input MAX (Hi)	(kW)	10,0	10,0
Heat input MIN (Hs)	(kW)	8,2	-
Heat input MIN (Hi)	(kW)	7,5	-
GAS supply pressure	(mbar)	37,0	37,0
NOZZLE pressure MAX	(mbar)	35,9	35,9
NOZZLE pressure MIN	(mbar)	20,0	-
Gas consumption MAX	(kg/h)	0,78	0,8
Gas consumption MIN	(kg/h)	0,58	-
Nozzle diameter	(mm)	1,60	1,6

IMPORTANT: "GAS supply pressure", defined as the dynamic pressure of the circuit, or part of the circuit downstream of the pressure reducer, with all the appliances running, and must be detected in this condition. With lower pressure difficulties in start-up may occur.

INSTALLATION

Ventilation of the ambient



Appliances must be installed in well-ventilated and manned ambient, in compliance with current legislation

The unit leaves the combustion products into the environment in which it is used (appliance type A1). It is therefore necessary to **ensure ventilation and air changes of the premises in which the appliance is installed**, realizing appropriate air outlet openings on the perimeter walls of the same, or creating a system of mechanical ventilation. To ensure a sufficient air change, the flow of air needed can be calculated using the following equation (UNI EN 13410):

$$V_{\text{tot}} = \Sigma Q_{\text{nb}} \times L$$

- V_{tot} air change flow rate in m³/h
- ΣQ_{nb} total heating power installed in the premises in kW
- L air change coefficient (must be ≥ 10 m³/h / kW)

IMPORTANT: air change coefficient "L" to be used **MUST NOT** be lower than **10 m³/h for each kW of installed power**

For NO reason the appliance(s) can be installed:

- in rooms smaller than 12 m³
- in ambient used as residential ambient
- where wind speed is higher than 2 m/s

Positioning

The appliance must be installed / suspended at ceiling (Picture 1). On top of the tube structure is welded a plate (Picture 2) drilled to balance the weight of the appliance. On request, S hooks and chains can be provided for **hanging installation**.



Picture 1

IMPORTANT: appliances must be installed **in vertical position**

Handling

During extraction of the appliances from package and for all operations of handling till final place of installation, must **NOT** be used as lifting points the gas group (cover, gas valve, flame control), the cover, the flexible gas pipe and the electric cable.

Appliances must be taken at the installation point / height using the tube structure or the drilled plate, welded on the upper part of the tube itself (Picture 2): **all other parts of the appliances are NOT designed to withstand its weight.**

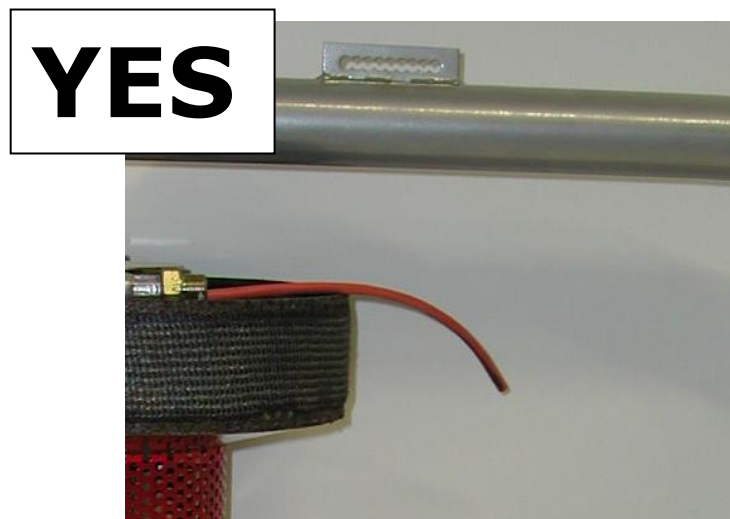

Picture 2

MINIMUM height of installation (for people comfort)

Indicative heights for the installation of appliances are as follows:

MODEL	HEIGHT of INSTALLATION (mt)	
	MIN	MAX
UFO EB / 08 (electronic start-up, TWO-STAGES version)	2,5	3,5
UFO M / 08 (manual start-up, ON-OFF version)	2,0	2,5

Height "MIN" means the minimum height at which the appliance should be installed so that people who are in radiated zone, **are not subject to excessive heat**.

Quotes relate to installation with **ambient temperature of 10 ÷ 12 °C**; in case of ambient with higher or lower temperatures the minimum height of installation must be reviewed; consider a reduction of 5 % (for temperatures lower of approx. 5 ° C) or increase of 5 % (for temperatures higher of approx. 5 ° C).

Above MINIMUM **heights of installation are indicative**, consult us each case to select the most advisable unit and the best height of installation (mostly for limit values).

MINIMUM distances from flammable surfaces

IMPORTANT: flammable materials inside the radiation could begin to burn and cause fires.



SURFACES CLOSE to APPLIANCES MUST BE DONE IN MATERIAL of CLASS 'A0' with respect TO FIRE RESPONSE (NOT COMBUSTIBLE and NOT FLAMMABLE) and with DEGREE of RESISTANCE TO FIRE EQUAL or MORE THAN "REI 90"

Minimum distances of installation must be respected between the heating surface of the appliances and the adjacent walls, **inside the area of radiation and outside**, if they are not protected against radiation or are flammable materials.

The **MINIMUM** distances are as follows:

MODEL	MINIMUM distance (mt) between appliance and ...			
	ceiling	floor	front	side
UFO EB / 08 and UFO M /08	0,7	2,0	1,0	1,0

NOTE – contact us in case of different distances or special cases

ASSEMBLING

Open the packing box and take out the appliance (Picture 1) and the aluminium cover (Picture 2).



Picture 1



Picture 2

Remove the nut and washer from the M8 pin, fixed on the upper part of the burner (Picture 3).



Picture 3

Place the cover (Picture 4); place the washer on the cover and use a CH13spanner to tighten the M8 nut to fix the cover. (Picture 5).

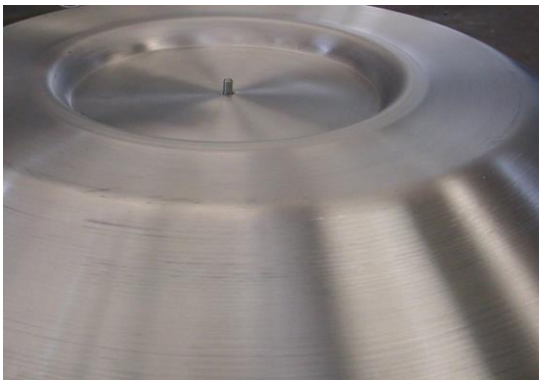

Picture 4



Picture 5

IMPORTANT: once installation is finished, check that power supply cable is not in contact with the aluminium cover (warm while appliance is running!!).

Connection to GAS supply

IMPORTANT: hydraulic connection of the appliances to the gas distribution net must be made according to information given in this technical book exclusively by professionally qualified staff.

The appliances are supplied according to the type of gas chosen, and then before making the connection to the power network of gas, **make sure that the gas used and pressure of gas circuit correspond to what is shown on the data plate label** of the unit. **Before connection to the gas pipeline, make sure that the pipes are properly cleaned and produced in accordance with regulations in force in the country of installation.**

NOTICE: provide a **fuel interception tap** close to the appliance, and with easily accessible position; make the **connection between the appliance and the gas network using an approved steel flexible pipe.**

IMPORTANT: "GAS supply pressure", defined as the dynamic pressure of the circuit, or part of the circuit downstream of the pressure reducer, with all the appliances running, and must be detected in this condition. With lower pressure difficulties in start-up may occur.

Once the connection is made, **in compliance with the rules in force in the country of installation, a)** verify the sealing of hydraulic pipes and gas connection to the unit, **b)** check that the pressure is correct, **c)** make sure that the apparatus functions in the conditions for which it was prepared.

- **UFO EB /08 = electronic start-up:** gas connection is 3/8". Appliances are equipped with a multifunctional group comprising: double seat valve fitted with pressure stabilizer and integrated flame control. The **stabilizer accepts a maximum inlet pressure of 50 mbar** and the valve is equipped with a pressure intake, to measure and control incoming and outgoing pressures.
- **UFO M /08 = manual start-up:** gas connection is 3/8". Appliances are equipped with valve tap, **pressure stabilizer for maximum inlet pressure of 50 mbar** with pressure intake at nozzle.

IMPORTANT: all appliances are **supplied already tested and set** to the properly operating pressure; **DO NOT remove seal on the pressure regulator (R): expiring of guarantee!**



Feeding gas pipeline **must be kept at a distance of at least 1 m from the zone of discharge of the combustion products** and **must not be exposed to direct irradiation of appliances**

Connection to ELECTRIC feeding (for appliance UFO EB /08 with electronic start-up)

IMPORTANT: the **electrical connection of the equipment shall be made in accordance with the directions given in this technical book** exclusively by professionally qualified personnel. **The installation must be carried out in accordance with regulations in the country of installation.**

The appliance must be fed with 230 Volt / Single Phase / 50 Hz feeding. The control flame mounted on gas valve has a plug/socket connection with security hook (picture 3). Mount a bipolar switch upstream of the heater for switch-on and switch-off, so you can isolate it from electric supply. Use this manual for the size of the power supply line, or refer to the data given in the plate label of the heater. In any case, use a cable with minimum section 4x1.5mm² (TWO-STAGE version).

The wiring diagram is shown on page 15 of this manual.

For the electrical connection unlock the plug and unscrew its case; connect a cable according to the indications given on the terminal plug, namely:

- L1** phase wire
- N** neutral wire
-  earth wire
- L2** modulator command for two-stage gas valve (if provided)
- L3** signal for burner block (if provided)

IMPORTANT: it is **essential** for the smooth functioning of the appliances, to **respect the Phase / Neutral polarity**, with that indicated on the power connector.

IMPORTANT: for safety of the user, and smooth functioning of the appliances, heater must be equipped with **efficient plant grounding**, executed according to existing regulations in the Country of installation. Under no circumstances you can use the gas connection pipeline as grounding of equipment.



NOTE for "SIT" TWO-STAGE gas valve

IMPORTANT:

- for this version, a specific switch for pressure modulator feeding must be placed in the main electric switchboard
 - modulator fed: HIGH pressure running
 - modulator NOT fed: LOW pressure running
- start-up of the appliance **must always take place** with the modulator fed (HIGH pressure running)
- you will find the data (heat input, pressure and gas flow rate) referring to the appliances with TWO-STAGE version, in the tables at page 6 of this manual.

N.B. – MINIMUM heating capacity = feed L1 + N
– MAXIMUM heating capacity = feed L1 + L2 + N

You will find the data (heat input, pressure and gas flow rate) referring to the appliances with TWO-STAGE version, in the tables at page 6 of this manual.

The TWO-STAGE version allows:

- save on gas consumption
- better comfort condition for people
- lower number of start-up / switch-off of the heater
- power reserve for particularly cold winters

Setting of the pressure

Unscrew the screw of the **PO** pressure intake of the gas valve before the nozzle (pictures 1.A and 1.B), and connect a water column manometer. Feed the modulator and take out the yellow tap of the pressure regulator. Act, as shown in picture 2, on the CH10 screw for setting of the maximum pressure, till you get the required pressure (**turn clockwise to increase and counter clockwise to decrease**). Take out tension at the pressure modulator, and with a screw-driver act on the inner screw for minimum setting (picture 3) till you get the required pressure (**turn clockwise to increase and counter clockwise to decrease**).

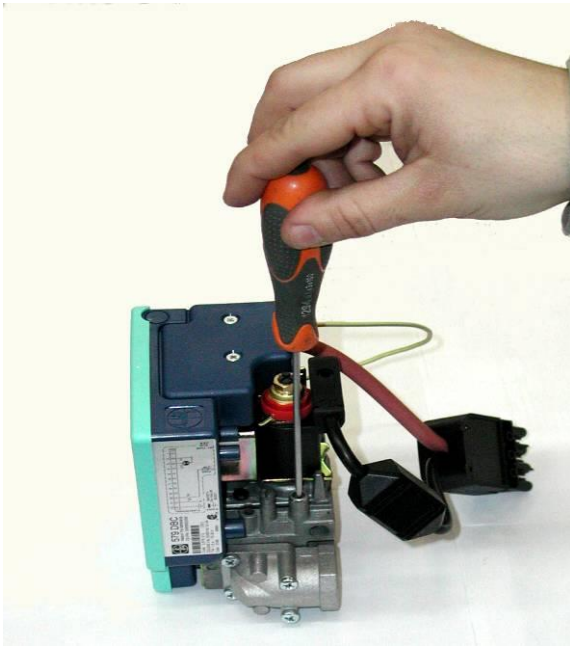

Picture 1.A

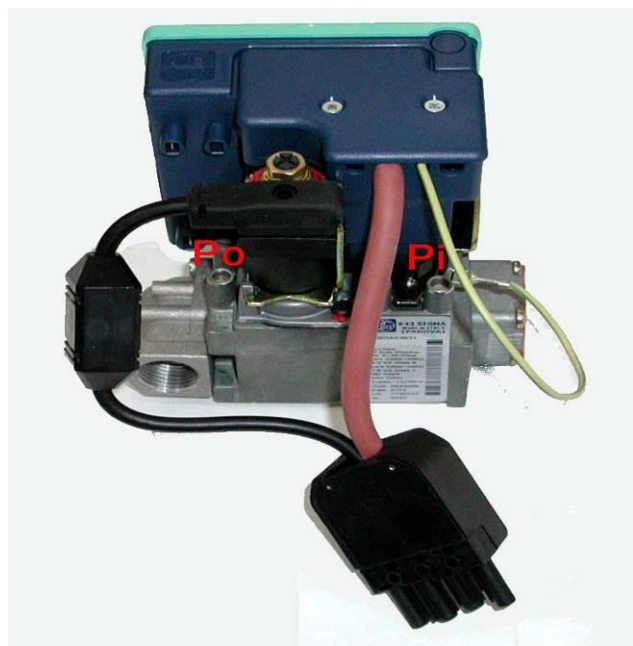

Picture 1.B



Picture 2



Picture 3

WIRING DIAGRAM, "SIT" control unit TWO-STAGE

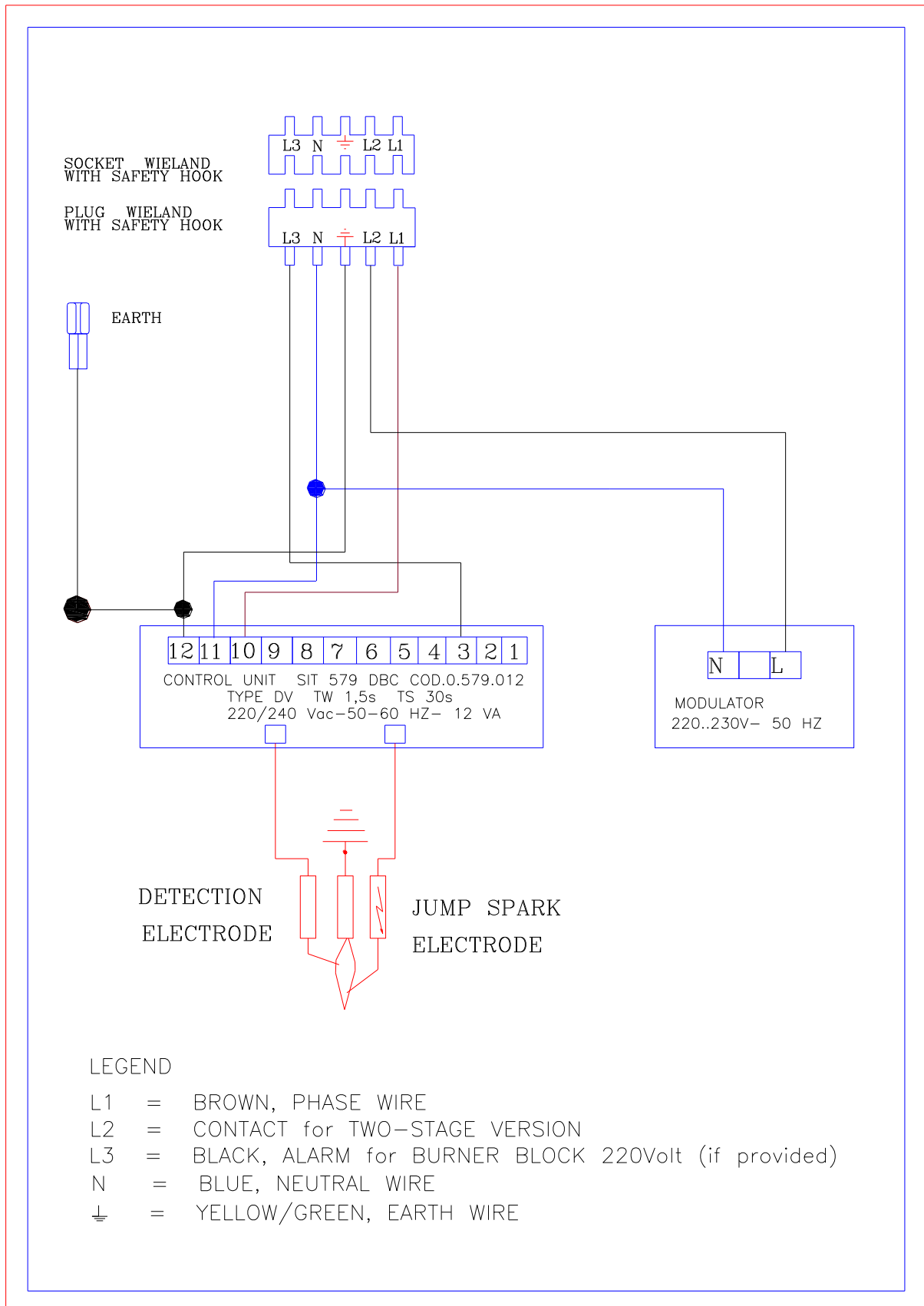

PUT IN OPERATION and FIRST START-UP (for all the models)

When you first start the appliances is important to **make some preliminary checks** to ensure its proper running; operations listed below are considered essential:

- make sure there are no losses in the gas line and that is properly sized
- **check that the pressure and type of gas used comply with the data on the plate of the characteristics of the appliance**
- check the correct mounting of gas group, gas valve and flame control, (only for appliance UFO EB /08, with electronic start-up)
- check that the power electric line has been correctly sized, which has been respected phase - neutral polarity and that the cable grounding is connected (only for appliance UFO EB /08, with electronic start-up)
- make sure the mechanical installation (supports) of the appliance have been properly carried out and that the connections bolts are tight
- use only steel materials, since heat is transferred from appliances to supports

Put in operation and first start-up for models with ELECTRONIC START-UP (appliance UFO EB /08)

For appliances equipped with **electronic system of start-up and flame control**, start-up sequence includes the following phases:

- giving tension to the appliances, ignition electrode begins sparking, and the gas valve opens
- the sparking electrode ends after 30 seconds
- in the case has not been detected the presence of flame, control flame goes into block after 30 seconds; for re-start it is necessary to remove tension for a period of not less than 20 seconds; after that period of time, the start-up sequence can be repeated; if the heater continues going into block, refer to the section 'Maintenance' of this manual
- switch-off of the appliance is done by taking out power supply to control unit

IMPORTANT: in case of failure at time of first start-up, **pressure settings have to be checked, acting on pressure intakes**

Only in case of maintenance, following instruction of qualified SIABS personnel, pressure settings can be modified using the following procedure:

- unscrew the 4 fixing screws of gas group cover (Picture 1), with a 8mm socket spanner



Picture 1



Picture 2

- remove the seal on the cap of pressure regulator
- unscrew the screw of intake pressure (Picture 2), upstream at the nozzle and connect a suitable gauge, to check correct pressure during setting

- remove the cap of pressure regulator (Picture 3) and act on the screw of adjustment (Picture 4) till match up to the pressure gauge reading with that stated on plate label (**turn clockwise to increase and counter clockwise to decrease**).

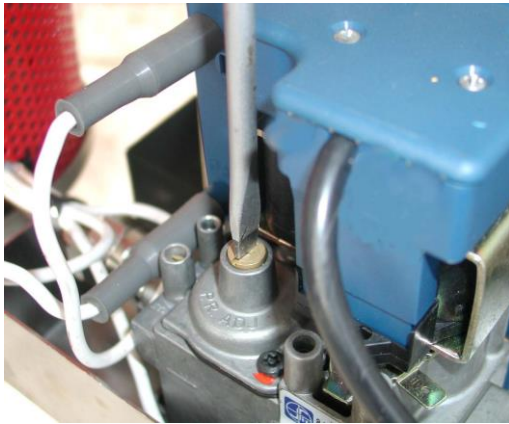

Picture 3

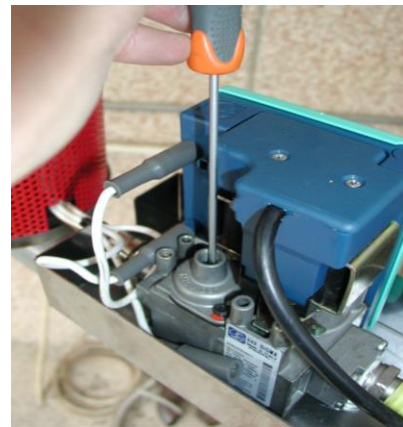

Picture 4

- the new and correct nozzle pressure should be checked at intake pressure (Picture 5)
- disconnect the pressure gauge and close the screw of intake pressure (Picture 6)



Picture 5



Picture 6

- reassemble the cap of the regulator and place a new suitable seal (Picture 7)
- mount the gas group cover (Picture 8) and tight the 4 fixing screws



Picture 7



Picture 8

Put in operation and first start-up for models with MANUAL START-UP (appliance UFO M /08)

For appliances with **manual start-up**, start-up sequence includes the following phases:

- push button of gas valve (Picture 1)
- push simultaneously the button of piezo-static starter till ignition takes place (Picture 2)
- press the button of the valve about 10sec. or until the activation of the electromagnetic part of the thermocouple
- switch-off of the appliance is done by closing gas supply to the

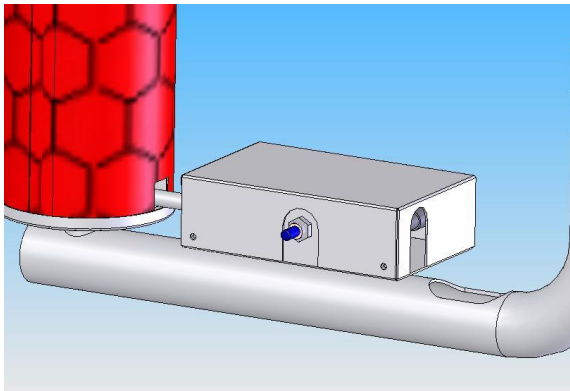

Picture 1

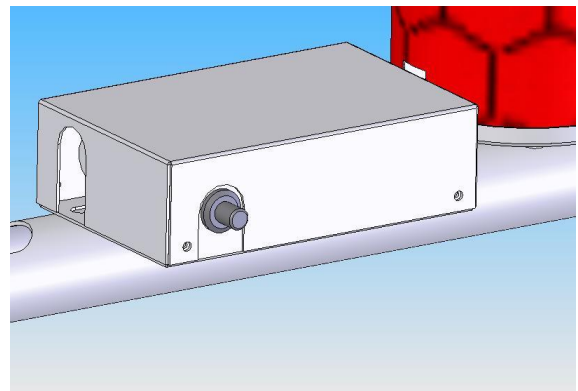

Picture 2

IMPORTANT: in case of failure at time of first start-up, **pressure settings have to be checked, acting on pressure intakes**

Only in case of maintenance, following instruction of qualified SIABS personnel, pressure settings can be modified using the following procedure:

- unscrew the screw of intake pressure, and connect a suitable gauge, to check correct pressure during setting (Picture 3)
- remove the cap of pressure regulator (Picture 3) and act on the screw of adjustment till match up to the pressure gauge reading (Picture 4) with that stated on plate label **(turn clockwise to increase and counter clockwise to decrease)**.
- disconnect the pressure gauge and close the screw of intake pressure
- reassemble the cap of the regulator and place a new suitable seal



Picture 3



Picture 4

MAINTENANCE

Ordinary maintenance

An appropriate use of the appliances, plus their proper and regular maintenance are essential to ensure better performance and longer working life.



Before making any maintenance, make sure that both the gas and the power supply have been excluded, and that the apparatus is cold. For all routine and / or extraordinary maintenance, contact only professionally qualified staff, or rather a Technical Assistance Centre authorized by SIABS

At least once a year before the season of use, it is strongly advisable to perform an intervention for control / inspection and cleaning:

- visual inspection of radiant surface (metallic fibre)
- cleaning of radiant surface with compressed air with LOW HUMIDITY at LOW PRESSURE
- nozzle cleaning
- electrodes cleaning, correct position and efficiency sparking
- check of keeping all the electrical connections
- search for possible losses on the gas circuit and gas valve
- check of gas pressure at nozzle
- general control of all components of the appliance
- control of openings and ventilation systems (natural and/or mechanical)
- control of alarm signals, if any

If the appliances are installed in dusty environments is advisable to clean more frequently the burners blowing compressed air with LOW HUMIDITY at LOW PRESSURE. In case the appliance is running, shut it down and wait, before you blow, that it is cold.

Nozzle replacement

In case you need to change the type of gas for which the appliance was prepared, you should contact SIABS to get the specific transformation kit, specifying the model of appliance, serial number and the new gas. The operations must be performed by qualified personnel and in compliance with the regulations.

IMPORTANT: If you change the **nozzle** to move to a different type of gas (f.e.: from LPG G30 to G20 natural gas) **it is COMPULSORY to change the PRESSURE STABILIZER – only for manual start-up version – and the plate label with technical data**, placing a new label with the new data, **repeat checks listed at page 20 "PUT IN OPERATION and FIRST START-UP"**, afterwards put seal again after operation.

To change the gas nozzle, act as follows:

- unscrew the 2 fixing screws and take out the protection grid (Picture 9)
- unscrew the 4 screw in the lower part (not loosen them up to the end) using a 8 mm socket spanner (Picture 10)
- using a CH13 spanner unscrew and take out the gas nozzle (Picture 11)
- screw down the new gas nozzle, mount the protection net and screw the 2 fixing screws

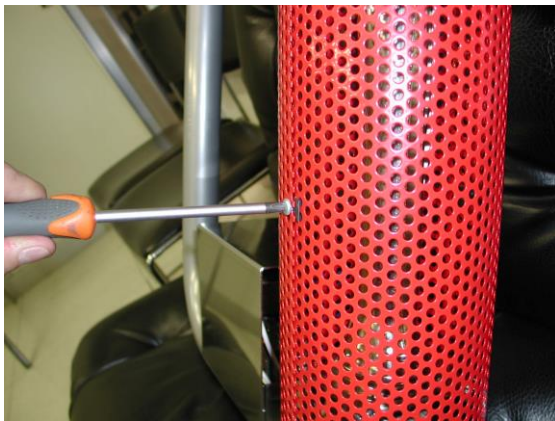

Picture 9



Picture 10



Picture 11

Trouble shooting

TROUBLE	POSSIBLE CAUSE	SOLUTION
A the heater turns on, the ignition electrode continues to sparkle then goes to block	A1 Phase and Neutral with wrong connection A2 The flame detection electrode is too far from radiant superface A3 The control unit is defective	A1 Check Phase / Neutral polarity and eart connection A2 Verify that the flame detection electrode is approx. 4 mm from the radiant surface A3 Replace the control unit
B the heater turns on partially	B1 Insufficient gas flow B2 Inlet gas pressure of the burner is too low B3 Dirty nozzle	B1 Check that gas supply has sufficient flow rate compared to gas consumption of the heater B2 Check that the gas pressure corresponds to that shown on the plate label B3 Clean nozzle with compressed air (NO mechanical device)
C the burner does flash-back	C1 Inlet gas pressure of the burner is too high C2 Burner or ceramic plates are dirty C3 Ceramic plates are cracked	C1 Check that the gas pressure corresponds to that shown on the plate label C2 After burner is cold, blow air at low pressure on the ceramic plates surface, from inside C3 Replace the ceramic plates
D the heater doesn't turn because no gas is getting	D1 Interruption in the elctric plant D2 No tension D3 Solenoid valve is live, but coils are not energized	D1 Verify voltage at connector of power supply D2 Replace the control unit D3 Replace the gas valve
E the ignition electrode doesn't sparkle, and burner goes to block	E1 The electrode doesn't spark because of wrong distance between its tip and earth E2 Power interruption E3 The spark of the ignition electrode starts close to the ceramic protection, due to its breakcage, or between cable and mass	E1 Adjust distance (closer or further) between tip of ignition electrode and mass : should be 3 ÷ 4 mm E2 Check contacts connection of electrodes and control unit E3 Replace the whole ignition and detection device, or just the cable, or just the electrode
F the gas valve turns on, but the heater doesn't turn and goes to block	F1 Air in the gas pipe F2 No gas	F1 Repeat the ignition cycle several times, waiting a time of approx. 20 sec between an ignition and the other F2 Verify that all devices of fuel interception, on gas pipeline, do not prevent passage

Serial number (bars code)

It is advisable to communicate us the **serial number** of the appliance(s) (label with bars code) for all operation of regular or extraordinary maintenance, and for orders of spare-parts.



On the structure tube



Outside, on packing box

Suggested SPARE-PARTS list

SPARE-PARTS list		
Description	Code	Quantity
. nozzle	various	_____
. kit for gas conversion = nozzle + plate label (page 5)	_____	_____
. start-up device (electrodes set)	08213411	_____
Model with ELECTRONIC start-up		
. SIT gas valve SIGMA 843 for models TWO-STAGES	2550000005	_____
. SIT flame control 579 DBC	2551000003	_____
. wiring (from flame control to electrodes)	_____	_____
. wiring (from flame control to plug)	_____	_____
Model with MANUAL start-up		
. SIT gas valve, model M1C – 3/8" M-M	2550000002	_____
. piezo starter, with wiring SIABS:A 1*0,75	PZ10026	_____
. thermo-couple	2552000021	_____
N.B. – specify appliance(s) model and gas type when ordering spare-parts		

Decommissioning and disposal

INFORMATION TO USERS "Implementation of Directives 2002/95/EC, 2002/96/EC and 2003/108/EC, relating to the use of hazardous substances in electrical and electronic equipment, as well as waste disposal"

The product at the end of its useful life **must be separated from other waste**. You should therefore **give the equipment at end of its working life to appropriate separate collection centres of electric and electronic waste**, or return it to the dealer when purchasing a new device to be equivalent in terms of one to one.

The proper differentiated collection to deliver the decommissioned apparatus to recycling, treatment and environmentally compatible disposal, helps to avoid possible negative effects on environmental and health, and promote the recycling of materials making up the equipment.

Illegal disposal of the product by the holder imply the application of administrative penalties according to law.



N.B. – Do not dispose of the product in mixed waste

CE certificate



Numero / Number: KIP-066847/01 Sostituisce / Replaces:
 Emesso / Issued: 22/02/2012 Scopo / Scope: Directive 2009/142/EC
 Rapporto / Report: 300965
 NIP/ PIN: 0694BS0965

CERTIFICATO DI ESAME CE DI TIPO EC TYPE EXAMINATION CERTIFICATE

Kiwa dichiara che i prodotti
Kiwa hereby declares that the products

diffusori termici a gas ad irraggiamento luminoso, tipo
non-domestic overhead luminous radiant heaters, type

Marchio / trade mark: **SIABS**

Modelli / models:	16P	10+10PSB	12PR	10PB	8PM
	16+16P	12+12PSB	12P	12PRB	M4D/06
	16PB	16+16PSB	10+10P	12PB	M6D/06
	16+16PD	4P	12+12P	10+10PB	3TG/06
	10+10PS	6P	4PB	12+12PB	5TG/06
	12+12PS	8P	6PB	4PM	UFO EB/06
	16+16PS	10P	8PB	6PM	UFO M/06

costruit da /

made by

di / in

SIABS S.r.l.
 Casorezzo (MI), Italia

soddisfano i requisiti riportati nella
meets the essential requirements as described in the
Direttiva Apparecchi a Gas 2009/142/CE
Directive on appliances burning gaseous fuels 2009/142/EC

I suddetti prodotti sono stati approvati per
Mentioned products have been approved for

Tipi di apparecchi / appliance type : **A₁**

Paesi e categorie apparecchi / Countries and appliance categories
 AL, AT, BE, BG, CH, CY, CZ, DE, DK, EE, ES, FI, FR, GB, GR, HR, HU,
 IE, IS, IT, LT, LU, LV, MK, MT, NO, NL, PL, PT, RO, SE, SI, SK, TR

I _{2H}	G2C	20 mbar	I _{3P}	G31	30 mbar
I _{2H}	G2C	25 mbar (HU only)	I _{3P}	G31	37 mbar
I _{2C}	G2C	20 mbar	I _{3P}	G31	50 mbar
I _{2E+}	G2C/G25	20/25 mbar	I _{3B}	G30	30 mbar
I _{2LL}	G2E	20 mbar (DE only)	I _{3B}	G30	50 mbar
I _{2L}	G2E	25 mbar (NL only)	I _{3BP}	G30	30 mbar
I ₃₊	G3C/G31	28-30/37 mbar	I _{3BP}	G30	50 mbar

Le famiglie di gas e gruppi di gas sopra indicati possono essere combinati per ottenere le categorie II e III secondo la norma EN437:2009.
The above gas families and gas groups can be combined to obtain categories II and III according to the standard EN437:2009.

Kiwa Italia S.p.a.

Sede Legale
 Via Mamei Goffredo, 20
 20129 Milano

Sede Amministrativa e operativa
 Via Trevisi, 32/34
 31020 Sar Venderiano (TV)
www.kiwa.com

GASTEC

Kiwa

Ing. Emanuele Ferrari
 Director Product Certification

kiwa
 Approved

EC Directive



2009/142/EC

GASTEC

CE
0694

DATE and STAMP

OPERATION / NOTES

DATE and STAMP

OPERATION / NOTES

DATE and STAMP

OPERATION / NOTES

DATE and STAMP

OPERATION / NOTES

SIABS S.r.l.
viale Del Lavoro, 7
20010 – Casorezzo (MILAN)
ITALY

to contact us:

Phone +39 02 90384081
E-mail commerciale@siabs.it
Web page www.siabs.com

Continuous development to improve the product could cause changes of above without notice.