

* BRACKET & DOME NOT IN BEL SCOPE, ONLY FIXING ARRANGEMENT TO BE PROVIDED

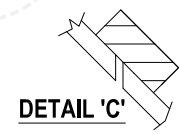
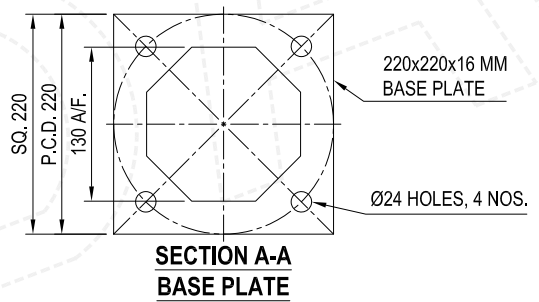
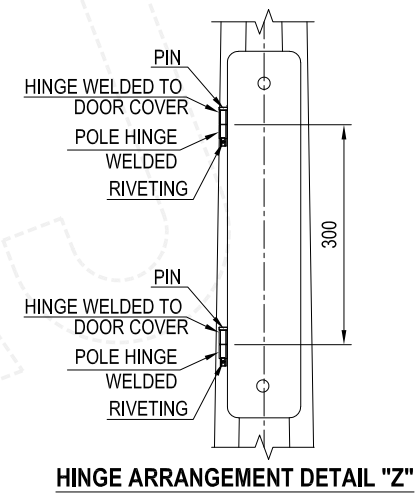
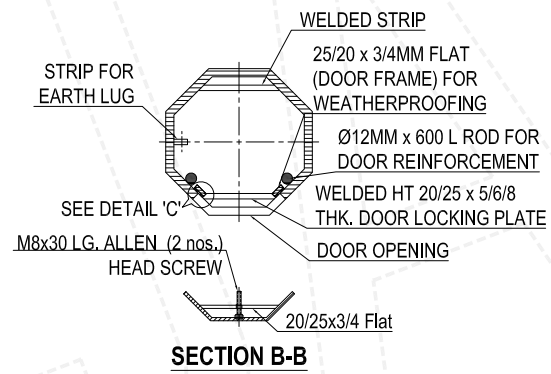
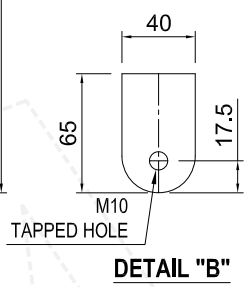
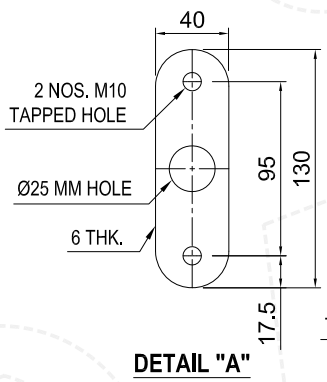
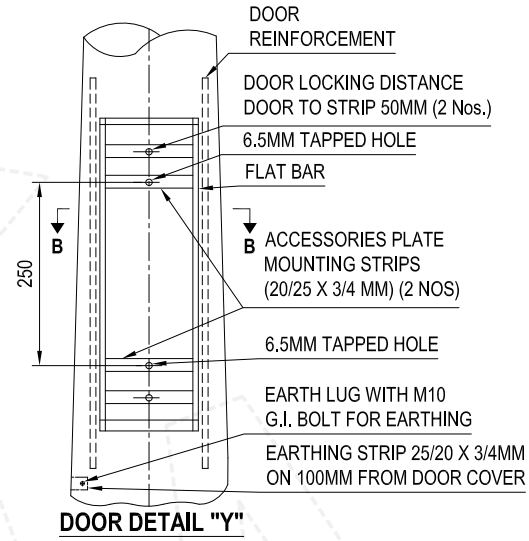
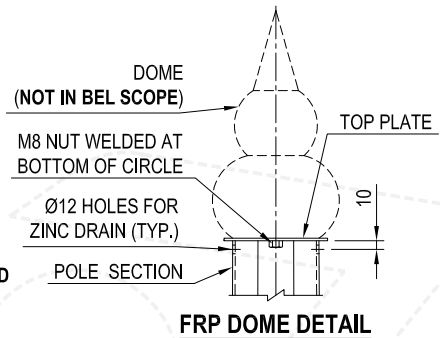

TOLERANCES :-	
DIAMETERS A/F	± 2.5 %
POLE TOTAL LENGTH	± 1.2 %
POLE STRAIGHTNESS	± 0.3 %

- WITHOUT BRACKET AND FOUNDATION BOLT.
- PROVISION OF HOLES FOR MOUNTING DOUBLE ARM SWORD TYPE BRACKET.

CLIENT	TURNING POINT		
PROJECT	STREET LIGHTING		
CONTRACTOR	---		
MANUFACTURER	 Engineering, Procurement, Construction Leaders in Lighting & Power Systems		
TITLE	GA DWG. OF 8M OCTAGONAL POLE WITH DA SWORD TYPE BRACKET	DATE	11.03.2020
DRWN BY	KMR	PROJECT CODE	DRG. NO.
DSSD BY	VA	1512003026	SHT 01 OF 01
CHKD BY	VA	DESIGN CODE	EPC-SL-20-1512003026-8M-001
APPRD BY	CSM	---	

This drawing is the property of "BAJAJ ELECTRICALS LTD." & must be returned on request. It is submitted as confidential information in connection with enquiry, tenders, orders or contracts. It is not to be used for any other purpose or order nor may it re-cooped or lent without our authority in writing.				
REV NO	DATE	REVISION DESCRIPTION	DRWN	CHKD
01	12.03.2020	FOR MANUFACTURING	KMR	VA