

\*SWORD BRACKET & FRP DOME NOT IN BEL SCOPE, ONLY MOUNTING ARRANGEMENT SHALL BE PROVIDED

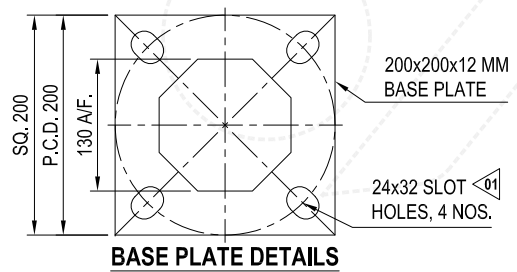

**BASE PLATE DETAILS**

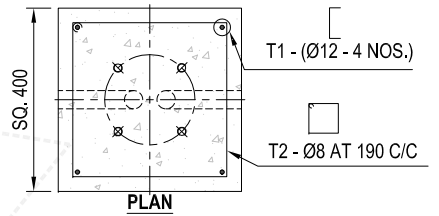

**PLAN**

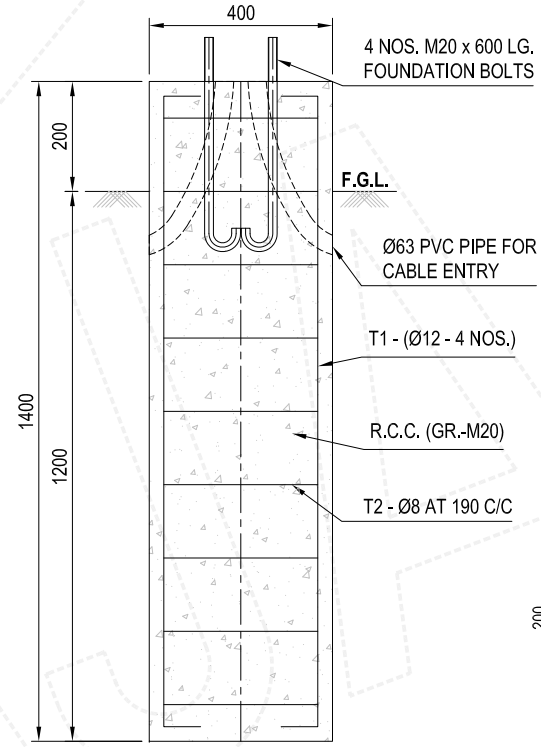

**DETAIL OF CIVIL FOUNDATION**

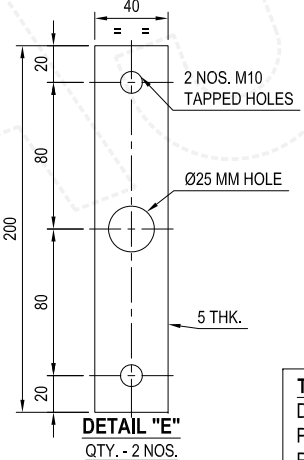

**DETAIL "E"**  
QTY. - 2 NOS.

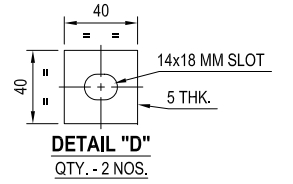

**DETAIL "D"**  
QTY. - 2 NOS.

TOLERANCES :-	
DIAMETERS A/F	± 2.5 %
POLE TOTAL LENGTH	± 1.2 %
POLE STRAIGHTNESS	± 0.3 %

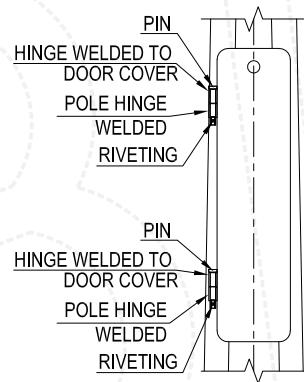

**HINGE ARRANGEMENT DETAIL "Z"**

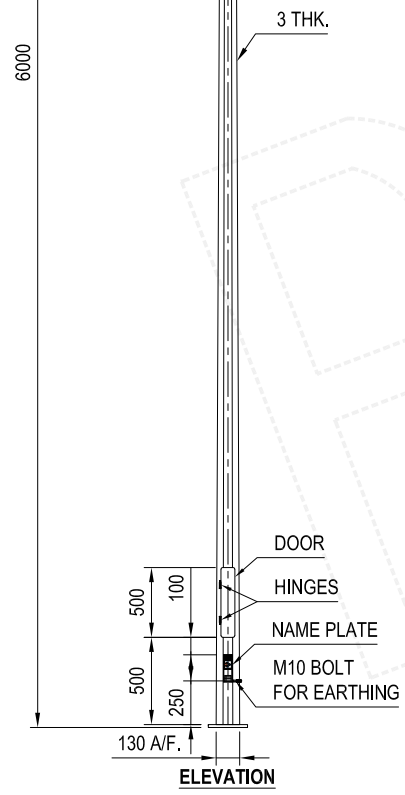

**ELEVATION**

- NOTES :-**
- ALL DIMENSIONS ARE IN M.M.
  - DESIGN STANDARD BS EN 40-3-1&3
  - DESIGN CRITERIA :
    - BASIC WIND SPEED - IS : 875 PART III : 2015
    - DESIGN LIFE - 25 YEARS.
    - TERRAIN CATEGORY - 2
    - TOPOGRAPHY - FLAT
  - MATERIALS :
    - SHAFT : HOT ROLLED STEEL PLATE CONFORM TO IS-2062/ BSEN 10025 OR EQUIVALENT GRADE.
    - FLANGE/GUSSETS/DOOR STIFFENER : AS PER IS-2062/ BSEN 10025 OR EQUIVALENT GRADE.
    - FOUNDATION BOLTS : EN-8 GRADE
  - FINISHING : HOT DIP GALVANIZED TO BS EN ISO 1461.
  - TOLERANCES SHALL BE AS PER BS EN 40-2 UNLESS OTHERWISE SPECIFIED IN THE DRAWING
  - MAKE OF THE POLE "BAJAJ".
  - THIS HAS TO BE READ IN CONJUNCTION WITH FINAL OFFER.

- FOUNDATION NOTES :-**
- ASSUMED S.B.C. - 10 T/M<sup>2</sup> (MINIMUM)
  - GRADE OF R.C.C - M20
  - GRADE OF STEEL REINFORCEMENT Fe 415 / Fe 500
  - CLEAR COVER TO REINFORCEMENT - 50 MM
  - CONCRETE VIBRATED
  - USE SHUTTERING

CLIENT	TURNING POINT		
PROJECT	STREET LIGHTING		
CONTRACTOR	----		
MANUFACTURER			
TITLE	GENERAL ARRANGEMENT DRAWING OF 6M OCTAGONAL POLE WITH SWORD TYPE DOUBLE ARM BRACKET		DATE 21.03.2023
DRWN BY	TM	PROJECT CODE	DRG. NO.
DSGD BY	HVR	-----	SHT 01 OF 01
CHKD BY	YT	DESIGN CODE	EPC-SL-23-43590-6M-OP-SWD-GAD
APPRD BY	SA	-----	

REV NO	DATE	REVISION DESCRIPTION	DRWN	CHKD	APPRD
01	21.03.2023	UPDATED FOUNDATION DRAWING	TM	YT	SA

This drawing is the property of "BAJAJ ELECTRICALS LTD." & must be returned on request. It is submitted as confidential information in connection with enquiry, tenders, orders or contracts. It is not to be used for any other purpose or order nor may it be re-copied or lent without our authority in writing.