

BASE PLATE DETAILS

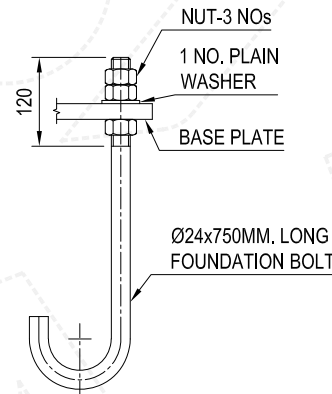

FOUNDATION BOLT DETAIL

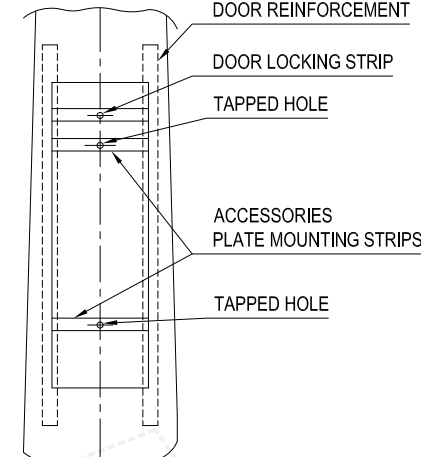

DOOR DETAIL "Y"

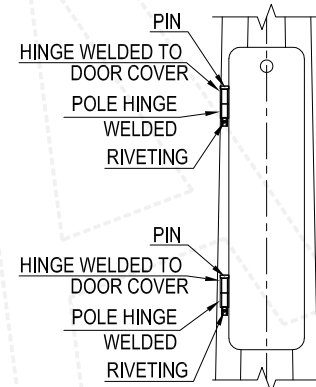

HINGE ARRANGEMENT DETAIL "Z"

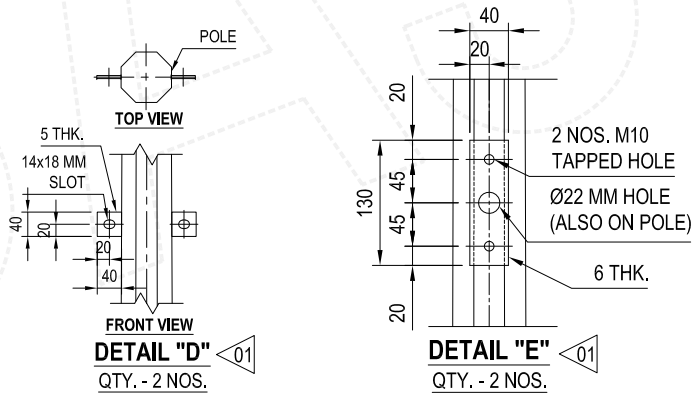

DETAIL "D" QTY. - 2 NOS.

DETAIL "E" QTY. - 2 NOS.

- NOTES :-**
- ALL DIMENSIONS ARE IN M.M.
 - DESIGN STANDARD BS EN 40-3-1&3
 - DESIGN CRITERIA :
 - BASIC WIND SPEED - IS : 875 PART III : 2015
 - DESIGN LIFE - 25 YEARS.
 - TERRAIN CATEGORY - 2
 - TOPOGRAPHY - FLAT
 - MATERIALS :
 - SHAFT : HOT ROLLED STEEL PLATE CONFORM TO IS-2062/ BSEN 10025 OR EQUIVALENT GRADE.
 - FLANGE/GUSSETS/DOOR STIFFENER : AS PER IS-2062/ BSEN 10025 OR EQUIVALENT GRADE.
 - FOUNDATION BOLTS : EN-8 GRADE
 - FINISHING : HOT DIP GALVANIZED TO BS EN ISO 1461.
 - TOLERANCES SHALL BE AS PER BS EN 40-2 UNLESS OTHERWISE SPECIFIED IN THE DRAWING
 - MAKE OF THE POLE "BAJAJ".
 - THIS HAS TO BE READ IN CONJUNCTION WITH FINAL OFFER.

TOLERANCES :-

DIAMETERS A/F	± 2.5 %
POLE TOTAL LENGTH	± 1.2 %
POLE STRAIGHTNESS	± 0.3 %

CLIENT	TURNING POINT			DATE	08.07.2024
PROJECT	STEET LIGHT PROJECT			SHT	01 OF 01
CONTRACTOR	-----			REV. NO.	00
MANUFACTURER				GENERAL ARRANGEMENT DRAWING OF 7M OCTAGONAL POLE WITH SWORD TYPE 1M DOUBLE ARM BRACKET	
TITLE	DRWN BY	DBA	PROJECT CODE	DRG. NO.	
	DSGD BY	SK	69590	EPC-SL-24-7M-OP-SWD-DAB-GAD-001	
	CHKD BY	VA	DESIGN CODE		
	APPRD BY	SA	-----		

This drawing is the property of "BAJAJ ELECTRICALS LTD." & must be returned on request. It is submitted as confidential information in connection with enquiry, tenders, orders or contracts. It is not to be used for any other purpose or order nor may it be re-copied or lent without our authority in writing.

REV NO	DATE	REVISION DESCRIPTION	DRWN	CHKD	APPRD
01	08.07.2024	REVISED AS PER MARKED.	DBA	VA	SA