



Product Catalogue

TW45C Drive

Legal information

All rights reserved

© Copyright by thyssenkrupp Aufzugswerke GmbH

Note on industrial property rights ISO 16016

Printed in Germany

This document – including excerpts – may only be reprinted or otherwise copied with the express written approval of thyssenkrupp Aufzugswerke GmbH.

Any duplication, dissemination or storage on data media unauthorised by thyssenkrupp Aufzugswerke GmbH is an infringement of copyright and shall give rise to prosecution.

Subject to change without notice

We expressly reserve the right to make changes of a technical nature for the purpose of improving our products or enhancing the safety standard - even without a separate announcement.

Choice of colours

The choice of colours used in our documents for the components is solely for illustration purposes in the documentation.

Contact your thyssenkrupp Aufzugswerke sales partner for details of colours for your specific products.

Issued by

thyssenkrupp Aufzugswerke GmbH

Bernhäuser Strasse 45

73765 Neuhausen a. d. F.

Germany

E-mail: Doku.elevator.plant.de@thyssenkrupp.com

Internet: www.thyssenkrupp-elevator-eli.de

Table of Contents

1	Product Family Description - Machines with Worm Gears	1
1.1	W Series machines	1
1.2	TW Series machines	1
2	Description - TW45C Machine	2
2.1	Machine location in machine room / vertical motor position IMV1	3
2.2	Machine location in machine room / horizontal motor position	4
2.3	Machine location in machine room / with emergency brake, NBS	6
2.4	Installation site of machine – machine room with horizontal rope departure direction – SA1.....	7
2.5	Machine location in machine room position with earthquake safeguard complying with EN81-77	8
2.6	Machine location in headroom (flange fixing)	9
2.7	Machine location in shaft pit (flange fixing).....	10
2.8	Machine location in shaft pit (foot mounting).....	11
3	Technology	12
3.1	Gear unit.....	12
3.2	Operational brake	13
3.3	Traction sheave	16
3.4	Motor versions	16
3.5	Machine versions	18
3.6	Combination of versions / options	23
3.7	Technical data	24
3.8	Maintenance instructions	29
3.9	Machine dimension sheets	29
3.10	Machine base frame	34
3.11	Machine base frame dimension sheets.....	40
3.12	Specification and order sheets.....	44
4	Scope of Supply and Packaging	45
4.1	Scope of supply	45
4.2	Packaging, shipping, storage on the construction site.....	46

1 Product Family Description - Machines with Worm Gears

ThyssenKrupp Aufzugswerke GmbH offers the following series of machines with worm gears:

Range of performance	W series machines		TW series machines	
	type	axle distance	type	axle distance
lower	-	-	TW45C	120 mm
lower / medium			TW63B	155 mm
medium			TW130	191 mm
medium / upper	W263C	263 mm	TW160	225 mm
upper	W332C	332 mm	-	-

TWM_10001_ENG

Table 1-1: Overview of product family - machines with worm gears

1.1 W Series machines

The designations of this model series (next generation of SO model series) consist of the combination of gear drive (W) and axle distance of the gear in mm (e.g. 332 mm), as well as an identifier for the generation (e.g. C).

These single-stage worm gears are designed with plain bearings except for the thrust bearing on the worm shaft. The lubrication used is a synthetic gear oil (polyalkylene glycol with additives) of viscosity class 220.

1.2 TW Series machines

The designation of this series (successor generation to the W Series) is derived from the combination of ThyssenKrupp Wormgear (TW) and a parameter for the main performance point (e.g. Q=1600 kg → 160) of the machine, as well as an identifier for the generation (e.g. B).

As part of technical further development, these machines are designed completely with low-friction rolling bearings.

The use of a synthetic gear oil (polyalkylene glycol with additives) of viscosity class 460 increases the power density and enhances the gear efficiency to achieve an extension of the oil change intervals.

2 Description - TW45C Machine

The TW45C machine (ThyssenKrupp Wormgear / Q = 450 kg / generation C) is used within the framework of the TW model series (machines with worm gears, anti-friction bearings, lubrication with synthetic gear oil) for traction elevators in the lower range of performance.

The TW45C has been available since May 2011 and it differs from the previous version TW45B in that there are modified anti-friction bearings with optimised sealing (stroke unit on worm shaft).

The TW45C machine, conceived for systems with rated load 450 kg at 1.0 / 1.25 m/s, consists of a worm gear with integrated operational brake, overhung traction sheave, flange-connected three-phase motor in IMB5/V1 structural shape as well as the optionally possible emergency brake, NBS.

The corresponding production, assembly and assignment of the components means that the versions of the machine described below are possible:

- Vertical upright motor position; traction sheave position on left / on right; with / without emergency brake system, NBS – for machine location in the machine room
- Horizontal motor position; traction sheave position on left / on right; with / without emergency brake system, NBS – for machine location in the machine room
- Horizontal motor position; traction sheave position on left / on right – for machine location in the headroom
- Horizontal motor position; traction sheave position on left / on right – for machine location in the shaft pit (e.g. Simpakt, Ecolift)

The machine is available exclusively with frequency-controlled motors (V3F).

2.1 Machine location in machine room / vertical motor position IMV1

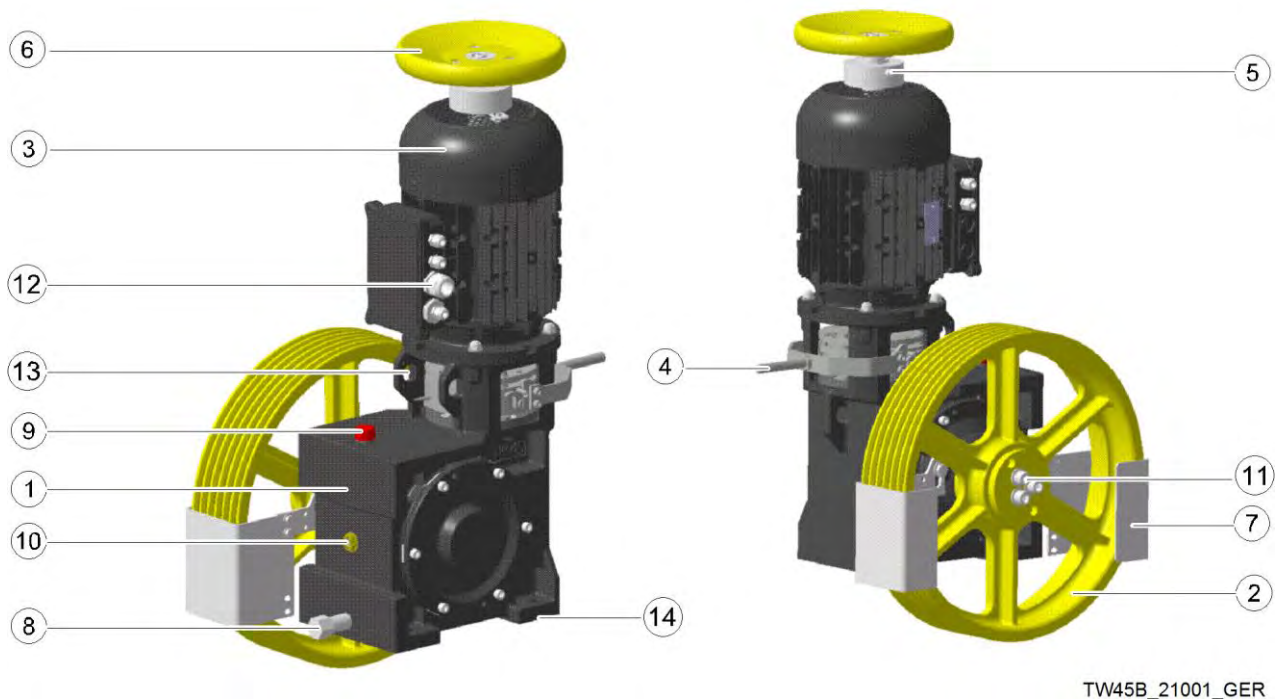

TW45B_21001_GER

Fig. 2-1: TW45C machine - version for location in machine room / vertical motor position IMV1 (shown with traction sheave position on left)

Description of items for Fig. 2-1

1	Driving gear (vertical motor position / mounting surface - foot)	2	Traction sheave (D360 / D440 / D520 / D590)
3	Motor (version with terminal box for connection of the operational brake)	4	Operational brake Mayr RSZ125-2x50 Nm including mounted lever for manual release
5	Actual-value sensor	6	Handwinding wheel (D270)
7	Rope guard (adjustable)	8	Oil drain (3/4")
9	Oil filling hole and ventilation (R3/4")	10	Oil level monitoring (gauge glass)
11	Traction sheave mount	12	Motor connection (M16x1.5 / M25x1.5) Brake connection (2 M16x1.5)
13	Transport eyebolts	14	Mounting surface of machine base frame (foot mounting)

2.2 Machine location in machine room / horizontal motor position

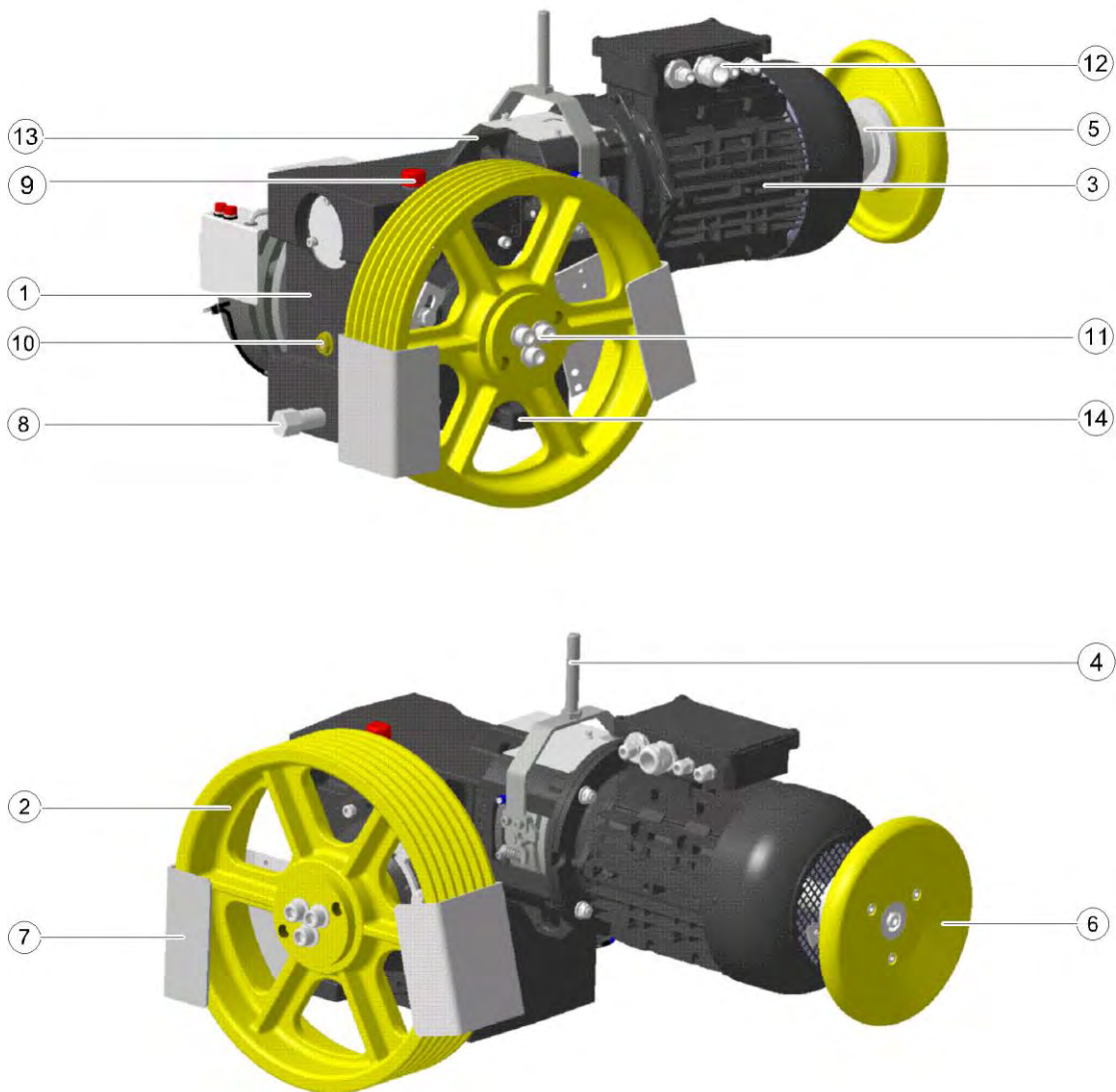

TW45B_22001_GER

Fig. 2-2: TW45C machine - version for location machine room / motor position horizontal IMB5 (shown with traction sheave position left, with emergency brake system)

Description of items for Fig. 2-2

1	Driving gear (horizontal motor position / mounting surface - foot)	2	Traction sheave (D360 / D440 / D520 / D590)
3	Motor (version with terminal box for connection of the operational brake)	4	Operational brake Mayr RSZ125-2x50 Nm including mounted lever for manual release
5	Actual-value sensor	6	Handwinding wheel (D270)
7	Rope guard (adjustable)	8	Oil drain (R3/4")
9	Oil filling hole and ventilation (R3/4")	10	Oil level monitoring (gauge glass)
11	Traction sheave mount	12	Motor connection (M16x1.5 / M25x1.5) Brake connection (2 M16x1.5)
13	Transport eyebolt	14	Mounting surface of machine base frame (foot mounting)

2.3 Machine location in machine room / with emergency brake, NBS

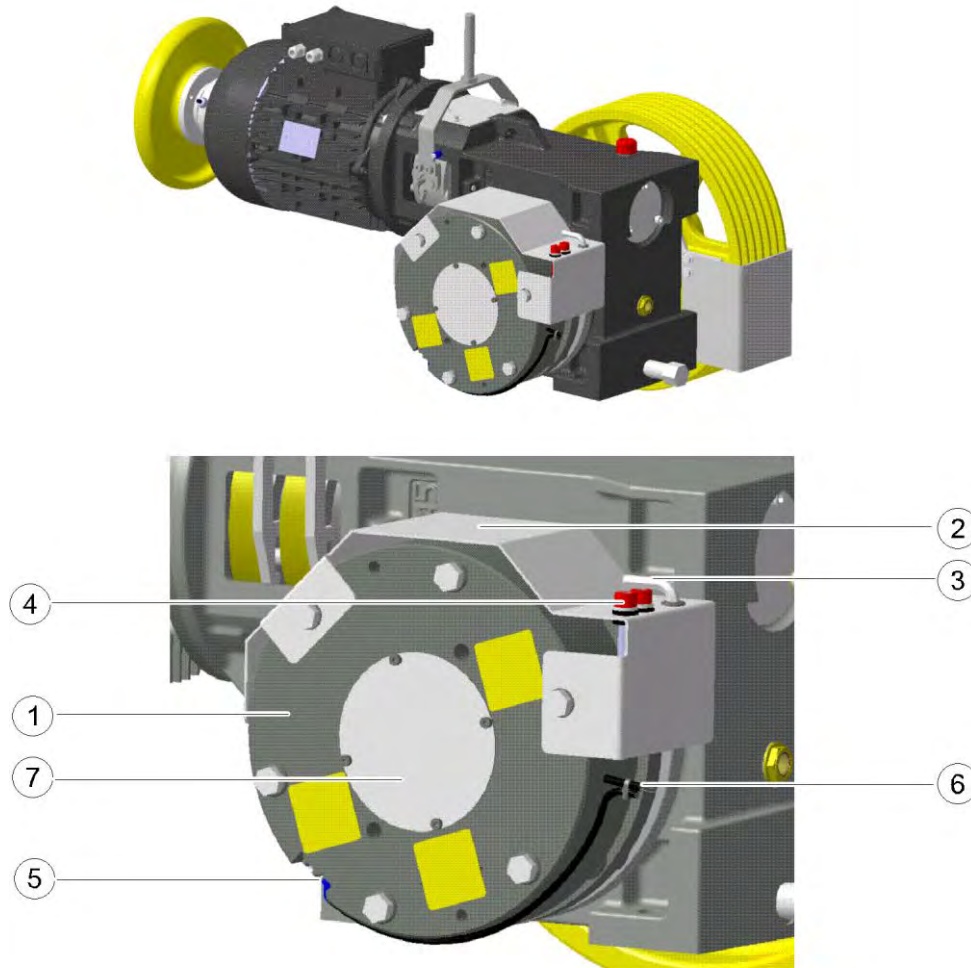

TW45B_23001_GER

Fig. 2-3: TW45C machine - version for location in machine room / with emergency brake, NBS (shown: horizontal motor position, traction sheave position–on left)

Description of items for Fig. 2-3

1	Disc brake - emergency brake system	2	Cover plate for brake
3	Socket wrench for manual release	4	Screws for manual release (screw head marked in red)
5	Brake test switch with connection line	6	Connection line, brake voltage
7	Protective cover for brake		

2.4 Installation site of machine – machine room with horizontal rope departure direction –SA1



Fig. 2-4: TW45C machine - version for installation site – machine room with horizontal rope departure direction – SA1 (shown: traction sheave position - left / motor position - horizontal)

The machine contains only the components for rope guard of the top rope line. To assist installation of these components, the bearing bracket on the traction sheave side has been fitted at the plant rotated by 60°.

The horizontal rope departure direction is possible in both directions (opposing the motor and/or towards the motor with horizontal motor position). With a vertical motor position, both horizontal directions are also possible.

The top rope guard can be adjusted +/- 15° in relation to the horizontal.

The additional components for the rope guard of the bottom rope line and/or in the area between the rope entry and departure points required in accordance with EN81-1:1998 and/or EN81-20/5.5.7 are not included in the scope of supply of the machine and must be fitted on the machine base frame depending on the order.

2.5 Machine location in machine room position with earthquake safeguard complying with EN81-77

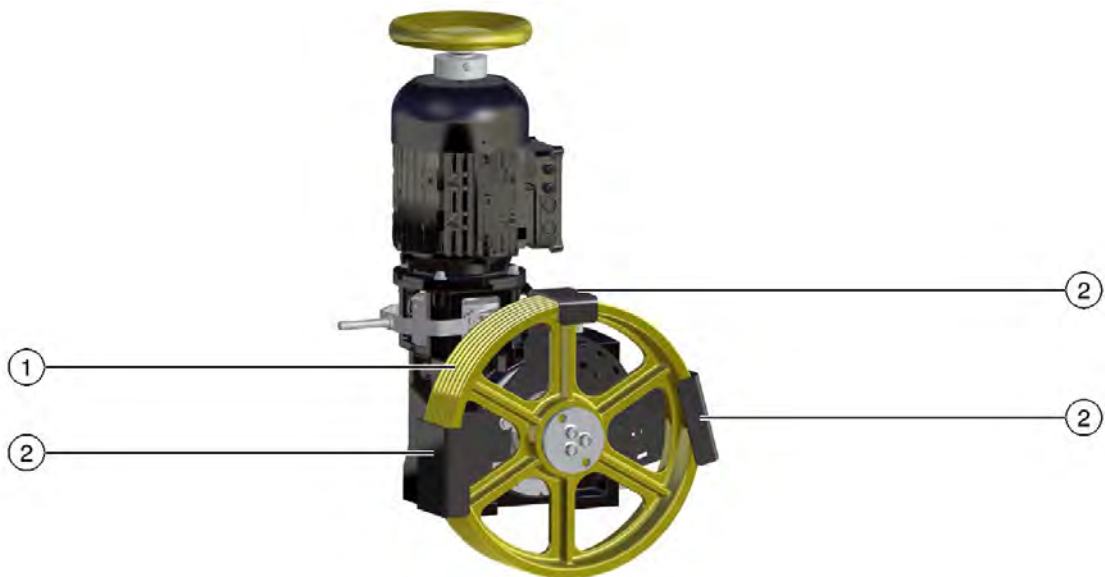

Fig. 2-5: TW45C machine - version for location in machine room (shown: traction sheave position on left / motor position vertical and earthquake safeguard complying with EN81-77)

Description of items for Fig. 2-5

1	Traction sheave (D360 / D440 / D520 / D590)	2	Earthquake safeguard complying with EN81-77
---	---	---	---

2.6 Machine location in headroom (flange fixing)

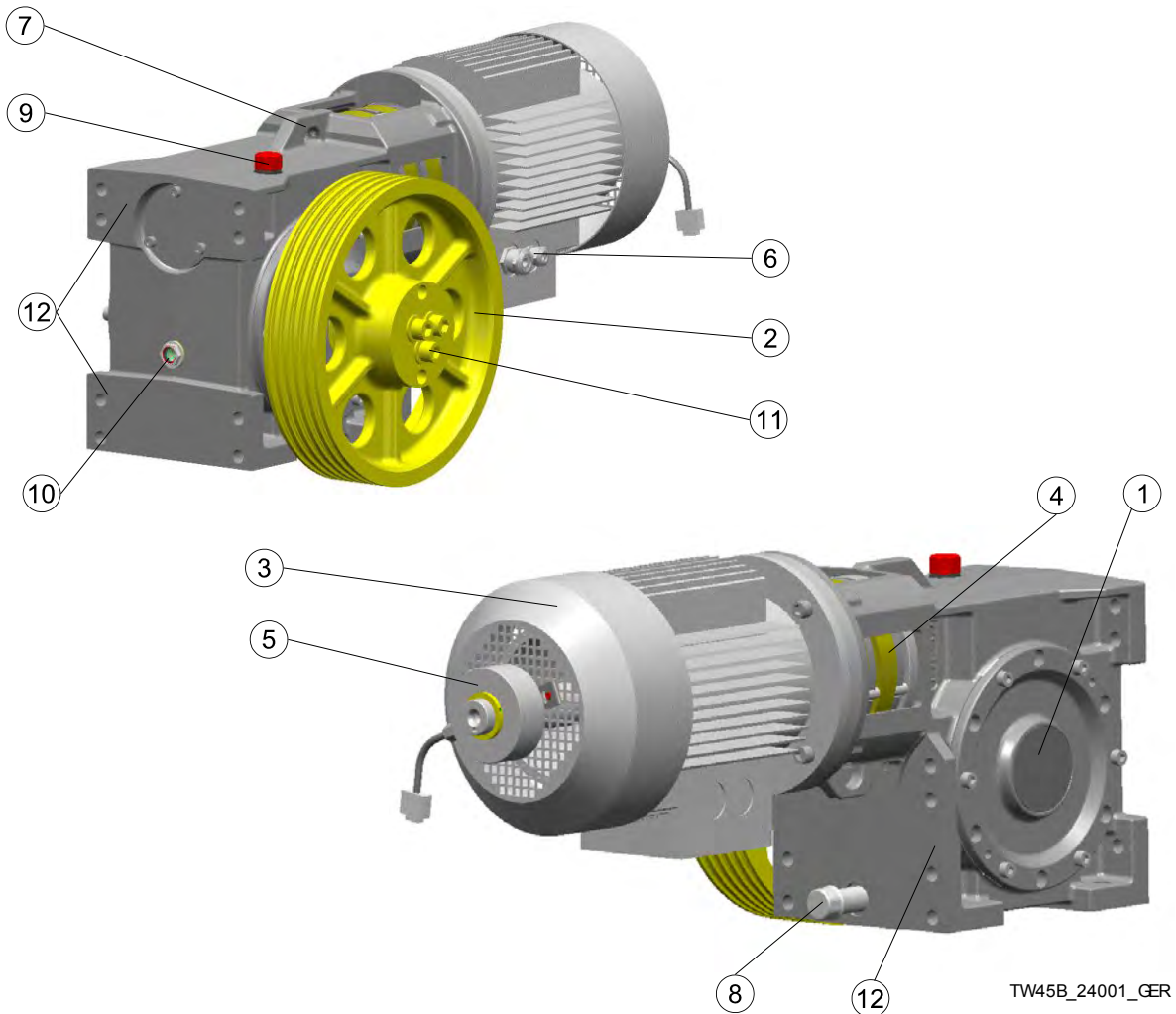
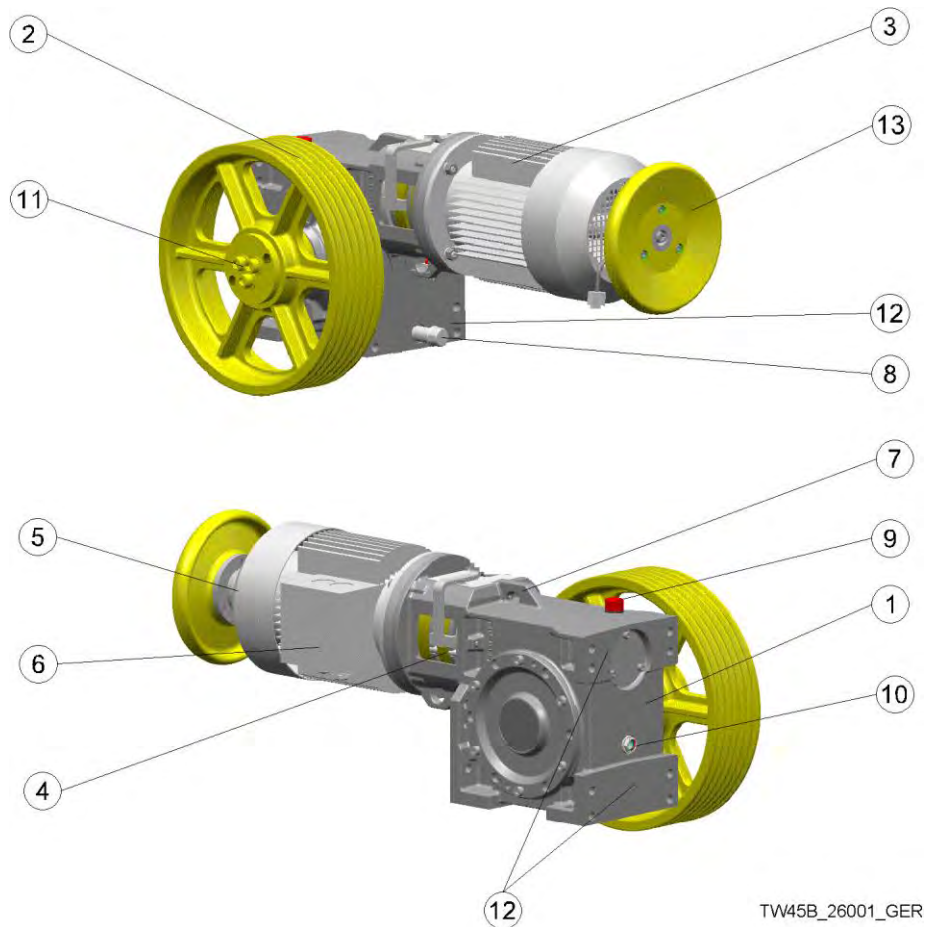

Fig. 2-6: TW45C machine - version for location in headroom
(shown: version with traction sheave position on left)

Description of items for Fig. 2-6

1	Driving gear (horizontal motor position / mounting surface - flange)	2	Traction sheave (D360)
3	Motor	4	Operational brake Warner SZ50/50 (2x50 Nm) including connection line 6 m
5	Actual-value sensor	6	Motor connection (M16x1.5 / M25x1.5)
7	Transport eyebolt	8	Oil drain (R3/4")
9	Oil filling hole and ventilation (R3/4")	10	Oil level monitoring (gauge glass)
11	Traction sheave mount	12	Mounting surfaces of machine base frame (flange fixing)

2.7 Machine location in shaft pit (flange fixing)



TW45B_26001_GER

Fig. 2-7: TW45C machine - version for location in shaft pit
(shown: version for Simpakt with traction sheave position on left)

Description of items for Fig. 2-7

1	Driving gear (horizontal motor position / mounting surface - flange)	2	Traction sheave (D360 / 440 / 520 / 590)
3	Motor (junction box at side)	4	Operational brake Warner SZ50/50 (2x50 Nm) including connection line 6 m
5	Actual-value sensor	6	Motor connection (M16x1.5 / M25x1.5)
7	Transport eyebolt	8	Oil drain (R3/4")
9	Oil filling hole and ventilation (R3/4")	10	Oil level monitoring (gauge glass)
11	Traction sheave mount	12	Mounting surfaces of machine base frame (flange fixing)
13	Handwinding wheel D270 (optional)		

2.8 Machine location in shaft pit (foot mounting)

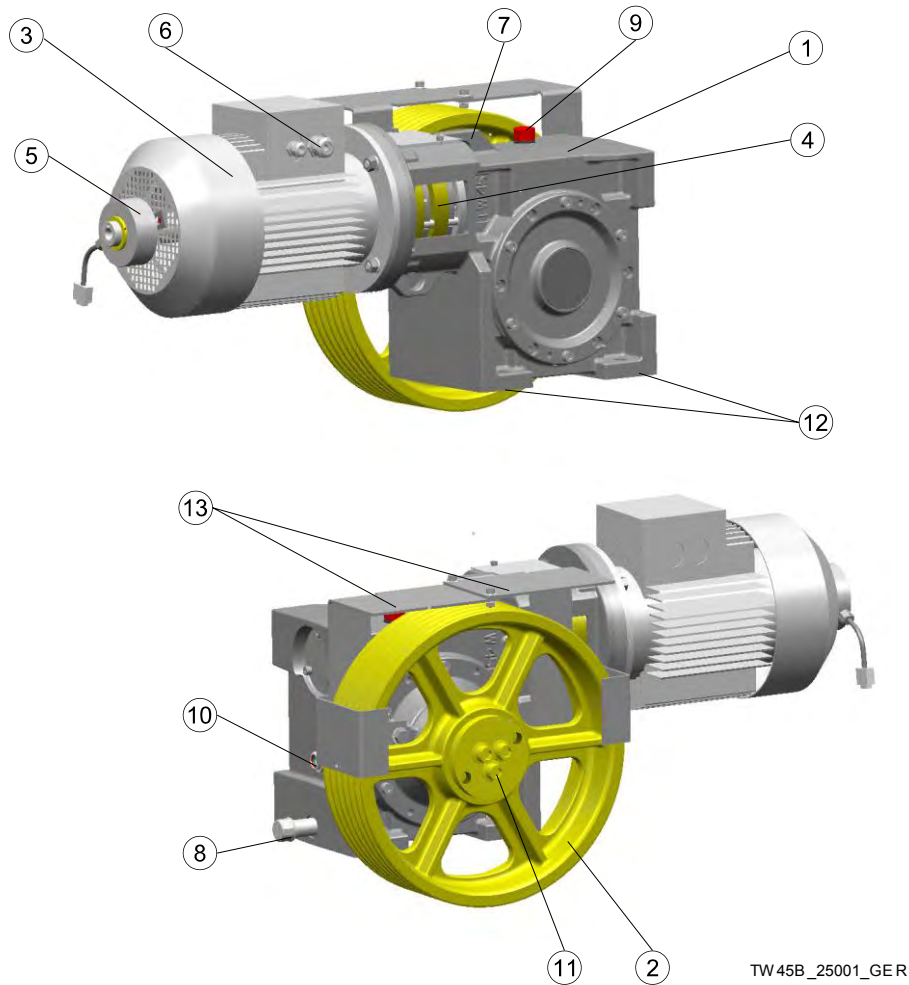

Fig. 2-8: TW45C machine - version for location in shaft pit
(shown: version for Ecolift with traction sheave position on left)

Description of items for Fig. 2-8

1	Driving gear (horizontal motor position / mounting surface - foot)	2	Traction sheave (D360, D440, D520/590)
3	Motor	4	Operational brake Warner SZ50/50 (2x50 Nm) including connection line 6 m
5	Actual-value sensor (handwinding wheel optional)	6	Motor connection (M16x1.5/M25x1.5)
7	Transport eyebolt	8	Oil drain (R3/4")
9	Oil filling hole and ventilation (R3/4")	10	Oil level monitoring (gauge glass)
11	Traction sheave mount	12	Mounting surfaces of machine base frame (foot mounting)
13	Components for the rope guard (only D440)		

3 Technology

3.1 Gear unit

Single-stage worm gear with:

- Housing in monoblock design (EN-GJL 250) with separate AS and BS bearing brackets
- Three housing variants, each design adapted for mounting surface to machine base frame and motor position:
 - Vertical motor position / mounting surface - foot (emergency brake NBS possible)
 - Horizontal motor position / mounting surface - foot (emergency brake NBS possible)
 - Horizontal motor position / mounting surface - flange (emergency brake NBS not possible)
- With deployment of the machine with the shaft pit location, the housing with mounting surface foot (e.g. Ecolift) or flange (e.g. Simpakt) is used depending on the installation situation
- Motor flange (construction size A250) integrated on housing
- Worm shaft made of case-hardened steel (16MnCrS5); optimised anti-friction bearings via stroke unit with life-time grease lubrication and optimised seal system
- Worm wheel made of centrifugally cast bronze (CuSn12Ni-C-GZ) with screw-connected hub
- Drive shaft made of tempering steel (C60), anti-friction bearings with oil-bath lubrication
- Contact pattern position of gear teeth adjustable; backlash not adjustable
- With vertical motor position, gear teeth run under oil; with horizontal motor position, with transport oil from oil sump via worm wheel gear teeth
- Oil level monitoring via gauge glass; oil drain (R3/4"); casing ventilation
- Components for the rope guard suitable for traction sheaves dia. 320 / 360 / 440 / 520 and 590 in accordance with EN81-1:1998 resp. EN81-20/5.5.7 (not generally with machine location in headroom or shaft pit or with horizontal rope departure direction).
- Machine name plate

name	unit	technical data
manufacturer		ThyssenKrupp Aufzugswerke
gear type		TW45C
axle distance	(mm)	120
ratios		40:3 / 41:2 / 32:1 / 46:1
oil filling	(L)	4.0 (horizontal motor position)
		5.0 (vertical motor position)
oil used		synthetic gear oil (Polyalkylenglykol with additives)
description		SM1
backlash	(°)	0.03 - 0.07
weight	(kg)	approx. 105

TW45B_30101_ENG

Table 3-1: Data for gear unit

3.2 Operational brake

Different versions of the operational brake are used, depending on the location of the machine.

The operational brakes integrated between the gearing and motor are redundantly structured electromagnetic 2-circuit disc brakes with an integrated elastic dog clutch (plug-in type) for the connection of motor and worm shaft.

3.2.1 Version for location in the shaft (MRL)

Designation	Unit	Technical data
Manufacturer		Warner Electric Europe
Type		Warner SZ50/50 Nm
Braking torque	(Nm)	2 x 50
Braking torque setting		Not possible
Design		2-surface disc brake arranged in tandem (2 brake circuits)
Brake linings		Made without asbestos
Brake disk diameter	(mm)	151
Air gap	(mm)	0.25 +/- 0.05
Air gap setting		Not possible
Electrical ventilation		1 magnetic clamp per brake circuit (series connection)
Operating voltage ¹⁾	(VDC)	180 - overexcitation 90 - holding voltage
Operating current ¹⁾	(A)	1.09 - overexcitation 0.72 - holding current
Performance data ¹⁾	(W)	196 - overexcitation 65 - holding power
Monitoring devices		none
Manual release		Manual release lever (not mounted) optionally possible
Length of connection cable	(m)	6 (including connectors/brake circuits externally connected in series)
Type of protection		IP54
Weight	(kg)	approx. 15
Type approval code		without (not required)

¹⁾ Values are valid for series connection of both braking circuits

TW45B_30201_ENG

Table 3-2: Data for operational brake - version for location in the shaft (MRL)

3.2.2 Version for location in the machine room

Designation	Unit	Technical data
Manufacturer		Chr.Mayr GmbH
Type		ROBA-stop RSZ125
Braking torque	[Nm]	2 x 50
Braking torque setting		not possible
Design		2-surface disc brake (2 mechanical brake circuits with a joint electromagnetic circuit for release)
Brake linings		asbestos-free
Brake disc diameter	[mm]	130
Air gap	[mm]	0.5 +0.25
Air gap setting		not possible
Electrical ventilation		1 magnetic clamp with armature base plate
Operating voltage	[VDC]	180 - overexcitation
		90 - holding voltage
Operating current	[A]	1.68 - overexcitation
		0.84 - holding current
Performance data	[W]	303 - overexcitation
		76 - stopping power
Monitoring devices		Release monitoring (microswitch)
Manual release		Manual release lever (permanently mounted) ¹⁾
Connection cable length	[m]	1 (with wire end sleeves; connection lines have an intermediate connection in the motor terminal box)
Protection class		IP54
Weight	[kg]	approx. 11
Type approval code		without (not required)

¹⁾ manual release of both brake circuits; single-circuit test by means of plug-in test gauge

TW45B_30202_ENG

Table 3-3: Data for operational brake - version for location in the machine room

This brake is generally designed with a brake monitoring device (microswitch).

3.3 Traction sheave

Depending on the location of the machine, different versions are standardised as traction sheaves.

The one-part traction sheaves are fastened overhung on the drive shaft by using a cone (1:15) and a mounting plate including 3 screws (M16-8.8 microencapsulated with locking washer).

name	unit	technical data				
diameter - DT	(mm)	320	360	440	520	590
rim width - B	(mm)	102	77	115		
max. number of grooves - z x d ²⁾		7 x 8	5 x 8	7 x 8	7 x 8	
			4 x 9	7 x 9	7 x 9	
				6 x 10/11	6x10/11	
					5 x 12	
groove type		seat / vee groove ¹⁾				
vee groove angle		depends on project specs ¹⁾				
groove clearance - RA						
standardized versions		7x8-S95-RA14.0	5x8-S85-RA14.5	4x8-K45-RA18.5		
			5x8-S90-RA14.5			
weight	(kg)	30	25	45	55	60
material		special alloyed EN-GJL 250				

¹⁾ Version in accordance with product description groove profiles with hardened groove flanks (min. 50 HRC).

²⁾ With minimum groove clearance - RA_{min} in accordance with product description groove profiles

TW45B_30301_ENG

Table 3-4: Traction sheave data

3.4 Motor versions

Frequency-controlled three-phase motors (manufactured by EME/CEG) are generally used. The mechanical layout (design IMB5/V1, flange A250, AS/BS shaft ends, encoder mounting etc.) is executed in accordance with building code BV 6531- 07 Sheet 1.

In extension of the building code, the motors are modified and receive a larger terminal box with the possibility to connect the connection lines of the operational brake (type Mayr RSZ 125) to a terminal block. For connection of the brake (coil and microswitch) on the installation side, 2 M16x1.5 cable glands are available on the motor terminal box.

Related to the motor shaft, mounting and thus the location of the motor connection box is possible under 4x90°.

The following motor operating data apply to deployment with TAW frequency inverters type CPI10E (IN = 12 A / IA = 18 A), CPI15/15E (IN = 18 A / IA = 30 A) and CPI26E (IN = 27 A / IA = 43 A).

name	unit	technical data			
manufacturer		EME (CEG)			
type		MT132STD 20197S	MT132STD 20193S		
motor type designation TKAW		C 5.2 400	C 7.0 400		
voltage/frequency	[V/Hz]	340/42			
S5 - operation data		180 c/h / 50% ED			
speed range	[1/min]	1000 → 1249	1250 → 1800	1000 → 1249	1250 → 1800
performance	[kW]	4.2 → 5.2	5.2	5.6 → 7.0	7.0
torque	[Nm]	40	40 → 28	54	54 → 37
rated current	[A]	12.5		16.5	
allowed starting torque	[Nm]	70	70 → 63	88	88 → 79
allowed starting current	[A]	20		25	
effective power	[V]	340		340	
cos φ		0.87		0.88	
efficiency		0.82		0.82	
structural shape		IMB5/V1			
type of protection		IP54			
ventilation		internal ventilator			
handwinding wheel ¹⁾	[mm]	D270 (plastic)			
kproj.	[mm]	485			
weight	[kg]	50		60	
real value generator (standard)		WDG100-38-1024/4096 TTL			
real value generator (special)		WDG100-38-1024 HTL / WDG100-38-1024 Sinus/Cosinus			

¹⁾ optional w ithout handwinding wheel for location of machine in headroom/pit

TW45B_30401_ENG

Table 3-5: Data for motor, encoder and handwinding wheel

The specified electrical data apply to the following site conditions:

- Max. altitude 1000 m amsl
- Max. temperature + 40 °C at max. 50% air humidity
- Max. relative air humidity 70% at 20 °C

If the conditions stated above are exceeded, the deratings in accordance with VDE0530 apply.

The encoders (description and technical data, see product catalogue for elevator motors) include a 10 m long connection cable, including connector (types 1024/4096 TTL) for connection to TAW frequency inverters or free cable ends with end sleeves (type 1024 HTL and type 1024 sine / cosine).

3.5 Machine versions

3.5.1 Standard version for machine location in the machine room

In the standard version for deployment in the machine room, the TW45C machine consists of the components:

- Driving gear (including oil filling) with mounting surface - foot - for horizontal / vertical motor position
- Gear ratios 46:1, 32:1, 41:2 or 40:3
- Operational brake type Mayr RSZ125-2x50 Nm including permanently mounted brake release lever and brake monitoring device (microswitch)
- Motor in version EME (CEG) MT132 (5.2 kW) or EME (CEG) MT132 (7 kW); mounting with terminal box location in accordance with Fig. 2-1 and as standard;
motor versions with intermediate terminal connection for connection lines of the operational brake
- Actual-value sensor; version WDG100-1024 TTL as standard
- Handwinding wheel dia. 270
- Traction sheave dia. 320 , dia. 440, dia. 520 or dia. 590 as standard
- Traction sheave dia. 360 is possible; the location of the traction sheave in relation to the machine altered by 5 mm is important here (dimension of middle of traction sheave to machine 195 instead of 200 mm)
- Components for the rope guard; standardised for traction sheave dia. 320, 360, 440, 520 and dia. 590
- Blocking clamp

3.5.2 Special versions

The following optional versions are possible:

- Emergency brake, NBS (only with machine location in the machine room)
- Actual-value sensor - special
- version for the machine location in the headroom
- Versions for machine location in the shaft pit
- Brake release lever (not fitted) for manual release of the operational brake type Warner SZ50/50-2x50 Nm with machine location in the shaft
- Earthquake safeguard complying with EN81-77 (only with machine location in the machine room, not for horizontal rope departure direction)
- Rope departure direction - horizontal (SA1); for further information see chapter 2.4.

Other special versions or options are currently not available.

3.5.3 Version with emergency brake, NBS

The optional version of the emergency brake (NBS) meets the requirements for the protection device that prevents overspeed in the upward-moving elevator car in accordance with EN81-1:1998 / 9.10 resp. EN81-20/5.6.6 and unintended elevator car movements in accordance with EN81-1:2010-06 / 9.11 (EN81-1/A3) resp. EN81-20/5.6.7.

Alongside the operational brake, an additional braking device is fitted on the drive shaft, consisting of the components:

- Type-approved electromagnetic disc brake in accordance with Table 3-5
- Driving gear in emergency brake system (NBS) version (bearing bracket NBS, brake flange NBS for fitting the brake)
- Traction sheave / worm wheel shaft NBS (including components for sealing)

The braking device is located on the machine side opposite the traction sheave and directly affects the traction sheave shaft.

The technical documentation must be attached a certificate for the calculation of the traction sheave shaft for the TW45C machine with emergency brake system (NBS).

The emergency brake is activated via a separate control unit including terminal box and connecting lines as well as an additional safety switch at the overspeed governor (Thyssen) to activate the facility in the event of overspeed.

The emergency brake is released manually (e.g. emergency rescue in the event of a power failure) via screws that are screwed into the brake in the event of triggering, thus releasing the brake / armature base plate of the disc brake. During normal operation, the screws and a socket wrench are kept in the guard plate of the brake.

For installation of the manual release screw, a minimum distance of 100 mm is to be set between the emergency brake and the adjoining wall of the machine room or similar.



Later fitting of the emergency brake, NBS, on existing machines is not possible.

name	unit	technical data
manufacturer		Chr. Mayr GmbH
type		Mayr RSO500/1200 Nm
braking torque	[Nm]	1200
braking torque adjustment		not possible
design		4-surface disc brake
brake lining type		made without asbestos
brake disc diameter	[mm]	213
air gap	[mm]	0.6
air gap adjustment/stroke		not possible
electrical ventilation		1 magnetic clamp with armature base plate
operating voltage	[VDC]	207 - overexcitation 104 - holding voltage
operating current	[A]	1.7 - overexcitation 0.85 - holding current
performance data	[W]	353 - overexcitation 88 - holding power
monotoring devices		ventilation monitoring (microswitch)
manual emergency ventilation		2 x M10 - screws
length of connection cable	[m]	approx. 1.0
type of protection		IP54
weight	[kg]	approx. 50
type approval sign		EU-BD 762 ²⁾ resp. ABV 762/2 ³⁾
type approval sign		EU-BD 762 ²⁾ resp. ESV 762/2 ³⁾
with reaction times t10 / t50 / t90 ¹⁾	[ms]	55 / 90 / 180
certificate for traction sheave shaft test number:		TW45C-RSO500/1200 Nm

¹⁾ DC-side shutdown (emergency stop)

²⁾ acc. to EN81-20/50

³⁾ acc. to EN81-1:1998+A3:2009

Table 3-6: Data for emergency brake - NBS

3.5.4 Version for the machine location in the headroom

The version of the machine for use in the headroom consists of the components:

- Driving gear (including oil filling) with mounting surface - flange and horizontal motor position
- Gear ratio 32:1 or 40:3; version 40:3 on installations with rope suspension 2:1 as standard
- Operational brake type Warner SZ50/50-2x50 Nm with separate brake circuits that can be released electrically and cable length 6 m
- Motor in version EME (CEG) MT132 (5.2 kW) or EME (CEG) MT132 (7 kW); mounting with terminal box location at bottom (see Fig. 2-6) as standard
- Actual-value sensor; version WDG100-38-1024 TTL as standard
- Traction sheave dia. 360/5x8; (groove type S85°)
- without handwinding wheel
- without components for rope guard (part of machine base frame)

3.5.5 Version for machine location in the shaft pit

The version of the machine for use in the shaft pit consists of the components:

- Driving gear (including oil filling) with mounting surface - foot and motor position vertical or horizontal (e.g. Ecolift) or with mounting surface flange and motor position horizontal (e.g. with Simpakt)
- Gear ratio 32:1 or 40:3; version 32:1 on installations with rope suspension 1:1 (e.g. for Ecolift); version 40:3 on installations with rope suspension 2:1 (e.g. for Simpakt)
- Operational brake type Warner SZ50 50-2x50 Nm with separate electrical-release brake circuits and cable length 6 m; optional with brake release levers for manual release (e.g. for Simpakt)
- Motor in version EME (CEG) MT132 (5.2 kW) or EME (CEG) MT132 (7 kW); mounting with terminal box location at top (e.g. for Ecolift, see Fig. 2-8) or at side (e.g. for Simpakt, see)
- Actual-value sensor; version WDG100-38-1024 TTL as standard
- Traction sheave dia. 440 as standard; dia. 520, dia. 590 and dia. 360 possible as options
- without handwinding wheel (e.g. for Ecolift); optionally with handwinding wheel (e.g. for Simpakt)
- Components for the rope guard suitable for arrangement of the machine in the shaft pit with rope departure direction vertically upwards ($\alpha = 180^\circ$) for traction sheave dia. 440 (e.g. for Ecolift)

3.5.6 Version with earthquake safeguard complying with EN81-77

The optional version of the rope guard complying with EN81-77 enables compliance with the requirements for protection devices in earthquake regions up to earthquake category 1 as standard.

The rope guard fitted as standard is replaced with the modified rope guard which, in the event of an earthquake, prevents the ropes from leaving the groove of the traction sheave.

Attention should be paid to ensuring that the rope guard is installed in accordance with the installation instructions.

The rope holder complying with EN81-77 is standardised for traction sheaves dia. 360 / 440 / 520 / 590, but not for traction sheave dia. 320.

The rope guard is designed in such a way that all standard gaps between the ropes on the rope departure can be covered with the TW45B O SR and TW45B M SR base frames.

3.6 Combination of versions / options

combination	46:1	32:1	41:2	40:3	C 5.2	C 7.0	RSZ125	SZ50/50	TWR	SK	SG	horizontal	upright	foot	flange	440	520	590	360	320	NBS	EN81-77	SA1
46:1																							
32:1	O																						
41:2	O	O																					
40:3	O	O	O																				
C 5,2	X	X	X	X																			
C 7,0	X	X	X	X	O																		
RSZ125	X	X	X	X	X	X																	
SZ50/50	X	X	X	X	X	X	O																
TWR	X	X	X	X	X	X	X	O															
SK	O	X	X	X	X	X	O	X	O														
SG	O	X	X	X	X	X	O	X	O	O													
horizontal	X	X	X	X	X	X	X	X	X	X	X												
upright	X	X	X	X	X	X	X	X	X	O	X	O											
foot	X	X	X	X	X	X	X	X	X	O	X	X	X										
flange	X	X	X	X	X	X	O	X	O	X	X	X	O	O									
440	X	X	X	X	X	X	X	X	X	O	X	X	X	X	X								
520	X	X	X	X	X	X	X	X	X	O	X	X	X	X	X	O							
590	X	X	X	X	X	X	X	X	X	O	X	X	X	X	X	O	O						
360	X	X	X	X	X	X	X	X	X	X	X	X	X	X	X	O	O	O					
320	X	X	X	X	X	X	X	X	X	X	X	X	X	X	X	O	O	O	O				
NBS	X	X	X	X	X	X	X	O	X	O	O	X	X	X	O	X	X	X	X	X			
EN81-77	X	X	X	X	X	X	X	X	X	O	O	X	X	X	X	X	X	X	X	O	X		
SA1	X	X	X	X	X	X	X	X	X	O	O	X	X	X	X	X	X	X	X	X	X	O	

explanation:

- | | |
|-----------------------------|--|
| X | combination possible |
| O | combination not possible |
| 46:1 / 32:1 / 41:2 / 40 :3 | version - gear ratio |
| C 5.2 / 7.0 kW | version - motor |
| TWR | machine location - machine room |
| SK | machine location - headroom |
| SG | machine location - pit |
| horizontal/upright | version - motor position |
| foot/flange | version - mounting surface (machine at machine base frame) |
| 440 / 520 / 590 / 360 / 320 | version - traction sheave |
| NBS | version with NBS emergency brake system |
| RSZ125 or SZ50/50 | version of operating brake |
| EN81-77 | Version with earthquake protection according to EN81-77 |
| SA1 | Version for horizontal rope exit |

TW45B_30601_ENG

Table 3-7: Overview of the combination options

3.7 Technical data

3.7.1 Performance chart

r	V _{nenn}	n ₁	DT	i	V _{n1}	Q' _{max}	F' _{max}	x	
1:1	0.50	1000	440	46:1	0.50	630	800	50	
						675		45	
	0.63	1250	440		0.63	550	850	50	
						630		45	
		1070	520		500	850	50		
					550		45		
		940	590		450	800	50		
					500		45		
	0.80	1600	440		0.80		450	800	50
							500		45
		1350	520				450		50
							500		45
		1190	590	400		50			
				450		45			
	1100	440	630	50					
	32:1	1.00	1390	440	1.00	550	850	50	
						630		45	
		1180	520	0.80	1.00	500	850	50	
						550		45	
						450		45/50	
		1040	590	0.63	1.00	450	850	45/50	
						630		50	
						675		45	
		1.25	1740	440	1.25	475	900	50	
						525		45	
			1470	520		425	900	50	
						475		45	
	1300	590	400	800	45/50				
450			45/50						
40:3	1.60	1650	590	32:1	1.60	350	700	50	
						375		45	
	1420	440	41:2	1.60	400	1000	50		
					450		45		
	1200	520	0.80	1.60	400	900	45		
					375		45		
	1060	590	0.63	1.60	375	850	45		
					450		45/50		

TW45B_30701_GER

Table 3-8: Performance chart, Part 1

r	V _{enn}	n ₁	DT	i	V _{n1}	Q' _{max}	F' _{max}	x	
2:1	0.40	1600	440	46:1	0.40	1000	1600	50	
		1350	520			900			
		1110	440			1300			
	0.50	1390	440	0.50	1150				
		1180	520		1050				
	0.63	1750	440	32:1	0.63	1000			
			520			900			
		1370	360		41:2	1200	1500	50	
			520			1350		45	
		1300	590		32:1	850	1600	50	
			440			41:2		1050	1500
	1200	440	41:2	1200	1400	45			
	0.80	1740	360	41:2	0.80	1050	1350	50	
			520			1200	1300	45	
		1420	440			950	1350	50	
			520			1050		45	
		1210	520			40:3	850	1350	50
			360				950		45
		1130	360			41:2	1200	1600	50
			590				750		
	1060	590	41:2	850	1400	45			
	930	440	40:3	1050	1500	50			
	1.00	1780	440	41:2	1.00	825	1300	50	
			520			900	1400	45	
		1510	360			40:3	750	1250	50
			590				41:2	825	1300
		1415	360			40:3	1050	1500	
			590				41:2	675	1300
		1330	590			40:3	750	1500	
	440		40:3	900	50				
1160	440	40:3	1000	1500	45				

TW45B_30702_GER

Table 3-9: Performance chart, Part 2

r	v _{nenn}	n ₁	DT	i	v _{n1}	Q' _{max}	F' _{max}	x
2:1	1.25	1660	590	41:2	1.25	600	1100	50
						675		45
		1450	440	40:3	1.25	825	1300	50
		1230	520			675	1200	
	1.60	1570	520		1.60	630	1000	
		1380	590			525		
	2.00	1730	590		2.00	475	1100	

explanation:

r	- rope suspension
v _{nenn}	(m/s) rated speed
n ₁	(rpm) motor speed
DT	(mm) diameter of traction sheave
i	- gear ratio
v _{n1}	(m/s) actual speed (with n ₁)
Q' _{max}	(kg) rated load (max.)
F' _{max}	(kg) mass of car (max. with Q' _{max})
x	(%) offset load

rope weights performance data incl. suspension rope weight for:
 FH = 20 m for v_{nenn} up to 0.63 m/s
 FH = 30 m for v_{nenn} up to 1.25 m/s
 FH = 40 m for v_{nenn} up to 1.60 m/s

TW45B_30706_ENG

Table 3-10: Performance chart, Part 3

All specified performance data apply to the following application conditions:

- Operating data max. 180 c/h at 50% duty cycle
- Ambient temperature + 5°C to + 40°C

For types of performance not shown in the chart or deviating installation data, there is the possibility to use a calculation program (e.g. TLD) to check the operational safety of the machine.

The machines are conceived for a service life of at least 15 years and/or 20,000 hours of operation.

3.7.2 Load data - traction sheave shaft

The load value F_{tzul} listed below is the limit value of the permitted radial stress for the traction sheave shaft calculated from the overall mass present on the installation.

The overall mass of the installation is determined and the load is checked as part of the calculation program TLD.

- Radial shaft load for $n_2 = n_1 / i \leq 50$ rpm: $F_{tzul} \leq 30$ kN
- Radial shaft load for $n_2 = n_1 / i > 50$ rpm: $F_{tzul} \leq 26$ kN
- There are restrictions for F_t for the rope departure directions horizontal and vertical upwards.
- The permitted loads and any necessary constructive measures are to be clarified with tkAW on request.

3.7.3 Gear efficiency

The specified gear efficiencies η_G and $\eta_{G'}$ are extreme values which are to be applied for dimensioning the motor, frequency inverter and braking resistor, etc.

The rated efficiency η_n provides information on the value η_G that can be achieved under optimum operating conditions.

The efficiencies η_{an} and $\eta_{an'}$ describe the state of gear starting (overcoming static friction or build-up of lubricating film in the gear teeth; at η_{an} values < 0.5 the gear, when stopped, must be viewed as self-inhibiting).

- η_g : minimum design efficiency, driving
- $\eta_{g'}$: maximum design efficiency, driven (braking)
- η_n : rated efficiency - driving
- η_{an} : starting efficiency - driving
- $\eta_{an'}$: starting efficiency - driven

ratio / speed (rpm)	η_g		$\eta_{g'}$		η_n	η_{on}	$\eta_{an'}$
	800 - 1249	1250-1800	800 - 1249	1250-1800	1250-1800	-	-
46:1	0.68	0.70	0.70	0.72	0.73	0.39	-0.08
32:1	0.72	0.74	0.74	0.76	0.77	0.46	0.18
41:2	0.80	0.82	0.82	0.84	0.85	0.56	0.47
40:3	0.86	0.88	0.88	0.90	0.91	0.66	0.66

TW45B_30703_ENG

Table 3-11: Gear efficiency

3.7.4 Mass moment of inertia

location machine	J _{rot}		machine room	headroom	
				pit	
ZB machine TW45C ¹⁾	(kgm ²)	0,0045	x	x	x
motor 5.2 kW	(kgm ²)	0,018	x	x	
motor 7.0 kW	(kgm ²)	0,024			x
handwinding wheel D270	(kgm ²)	0,01	x		
ZB machine complete	(kgm ²)	-	0,0325	0,0225	0,0285

¹⁾ incl. traction sheave

TW45B_30704_ENG

Table 3-12: Mass moment of inertia

The mass moment of inertia for versions of the machine not listed in the table is to be determined according to the details of the individual components.

3.7.5 Weight data

machine location	m (kg)	machine room				headroom	
		landing pit					
ZB machine TW45C ¹⁾	120	x	x			x	x
ZB machine TW45C ²⁾	160			x	x		
motor 5.2 kW	50	x	x	x	x	x	
motor 7.0 kW	60						x
traction sheave D590	60						
traction sheave D520	55		x		x		
traction sheave D440	45	x		x			
traction sheave D360	25					x	x
traction sheave D320	30						
ZB machine complete	-	215	225	255	265	195	205

¹⁾ version without emergency brake

²⁾ version with NBS emergency brake system

TW45B_30705_ENG

Table 3-13: Weight data

The overall mass for versions of the machine not listed in the table is to be determined according to the weight data of the individual components.

3.7.6 Acoustic specifications

Airborne noise levels in the machine room at a distance of 1 m during operation at normal rating at the TKAW frequency inverter:

- approx. 63 dB(A) at motor speed $n_1 \leq 1250$ rpm
- approx. 65 dB(A) at motor speed $n_1 \leq 1500$ rpm
- approx. 67 dB(A) at motor speed $n_1 \leq 1800$ rpm

3.8 Maintenance instructions

- Oil change: for the first time after 4 years, then every 8 years
- Other components: maintenance-free

3.9 Machine dimension sheets

3.9.1 Version for machine location in machine room / vertical motor position IMV1

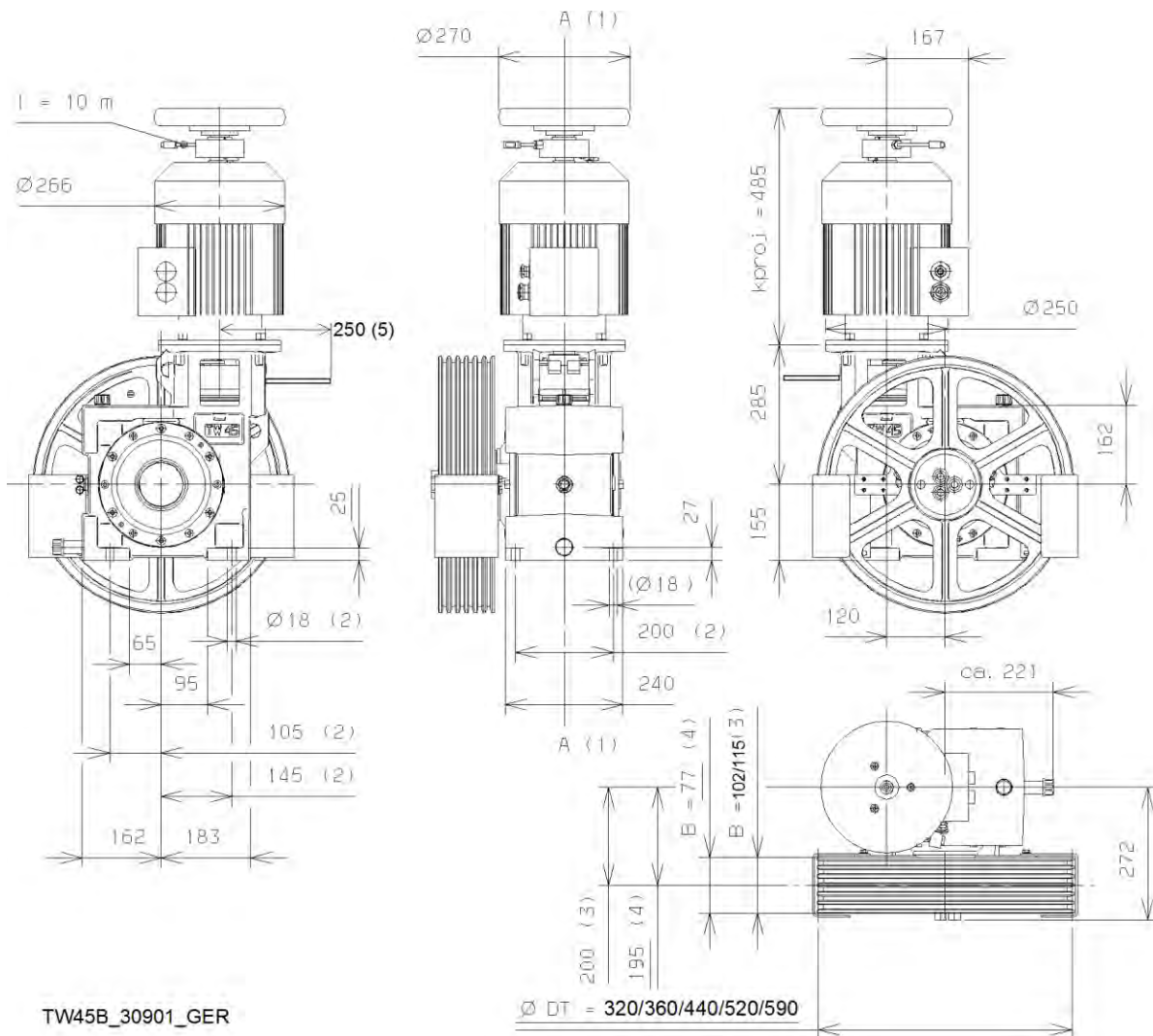

Fig. 3-1: TW45C machine - version for location in machine room / vertical motor position IMV1 (shown: traction sheave position on left)

Description of items for Fig. 3-1

(1)	Traction sheave position on right, mirror-inverted to A-A	(2)	Screwed connections - machine base frame M16 -8.8
(3)	with DT = 320 (B=102) / 440 / 520 / 590	(4)	with DT = 360
(5)	manual brake release for brake Mayr RSZ125-2x50 Nm		

3.9.2 Version for location in machine room / motor position horizontal IMB5 in combination with emergency brake NBS (optional)

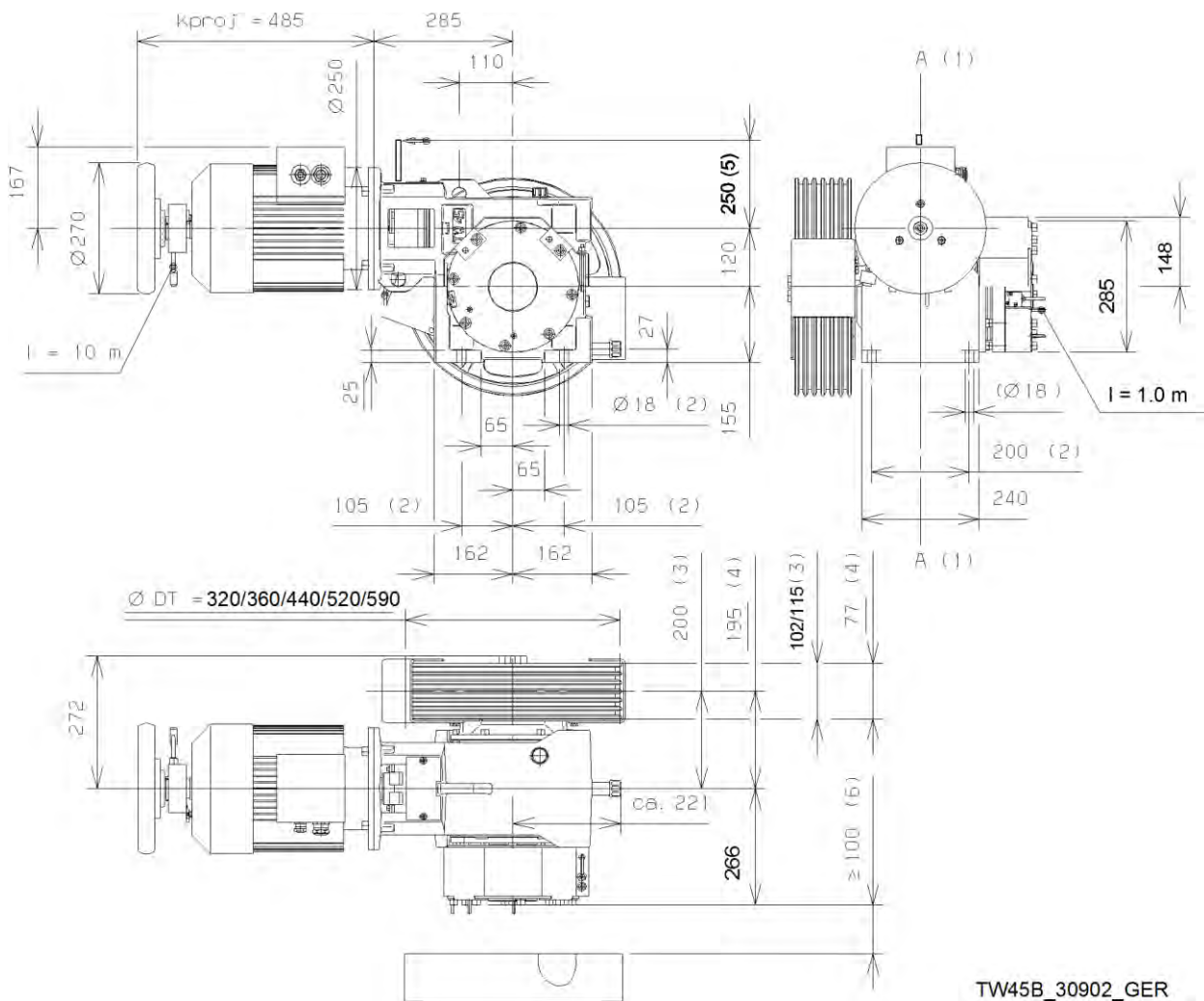
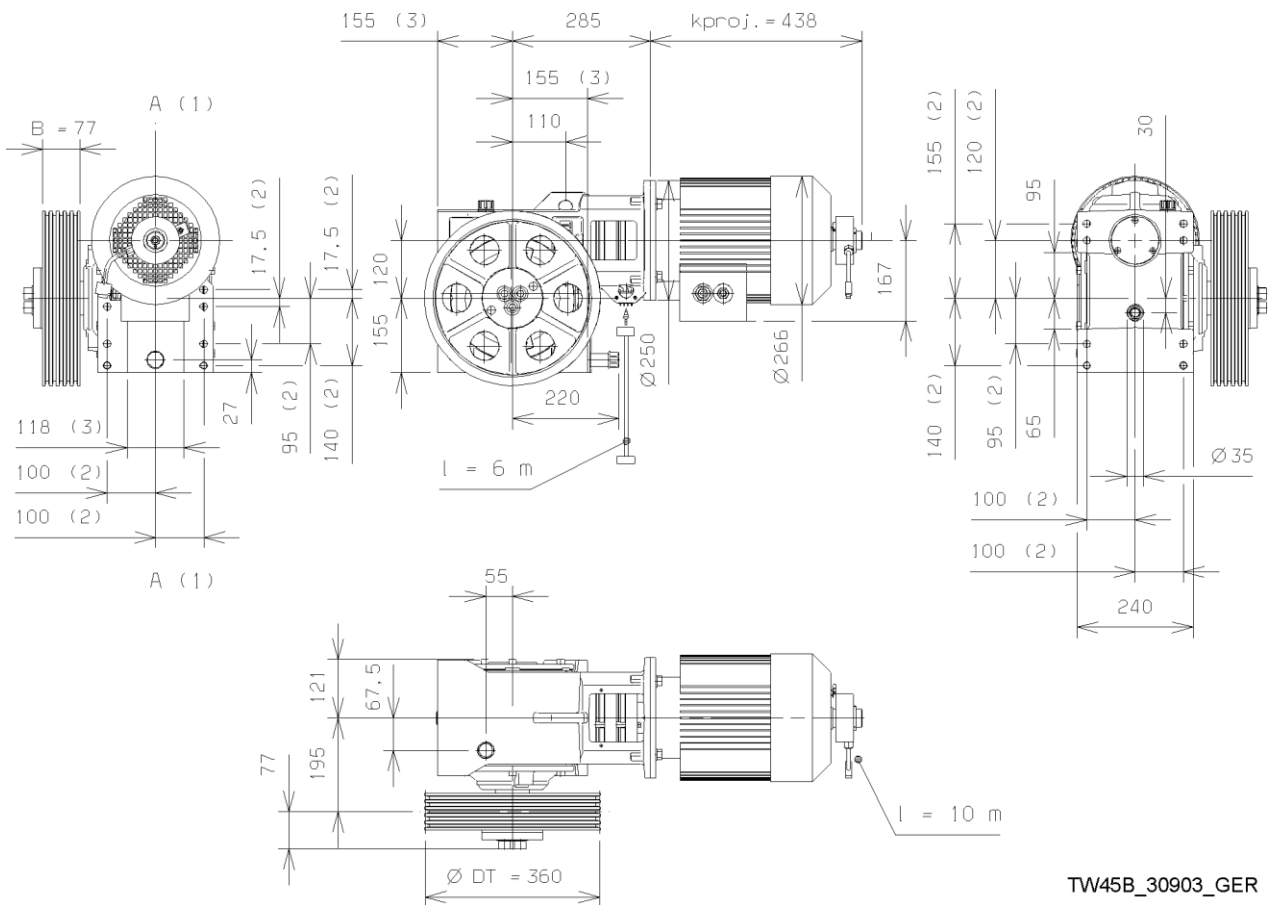

Fig. 3-2: TW45C machine - version for location in machine room / motor position - horizontal IMB5 with emergency brake NBS - shown: traction sheave position - on left)

Description of items for Fig. 3-2

(1)	Traction sheave position on right, mirror-inverted to A-A	(2)	Screwed connections - machine base frame M16 -8.8
(3)	with DT = 320 (W=102) / 440 / 520 / 590	(4)	with DT = 360
(5)	manual brake release for brake Mayr RSZ125-2x50 Nm	(6)	Clearance for manual release of the emergency brake, NBS

3.9.3 Version for machine location in headroom



TW45B_30903_GER

Fig. 3-3: TW45C machine - version for location in headroom
(shown: version with traction sheave position on left)

Description of items for Fig. 3-3

1	Traction sheave position on right, mirror-inverted to A-A	2	Thread M16x25 deep
3	Mounting surfaces - machine base frame		

3.9.4 Version for machine location in the shaft pit (flange fixing)

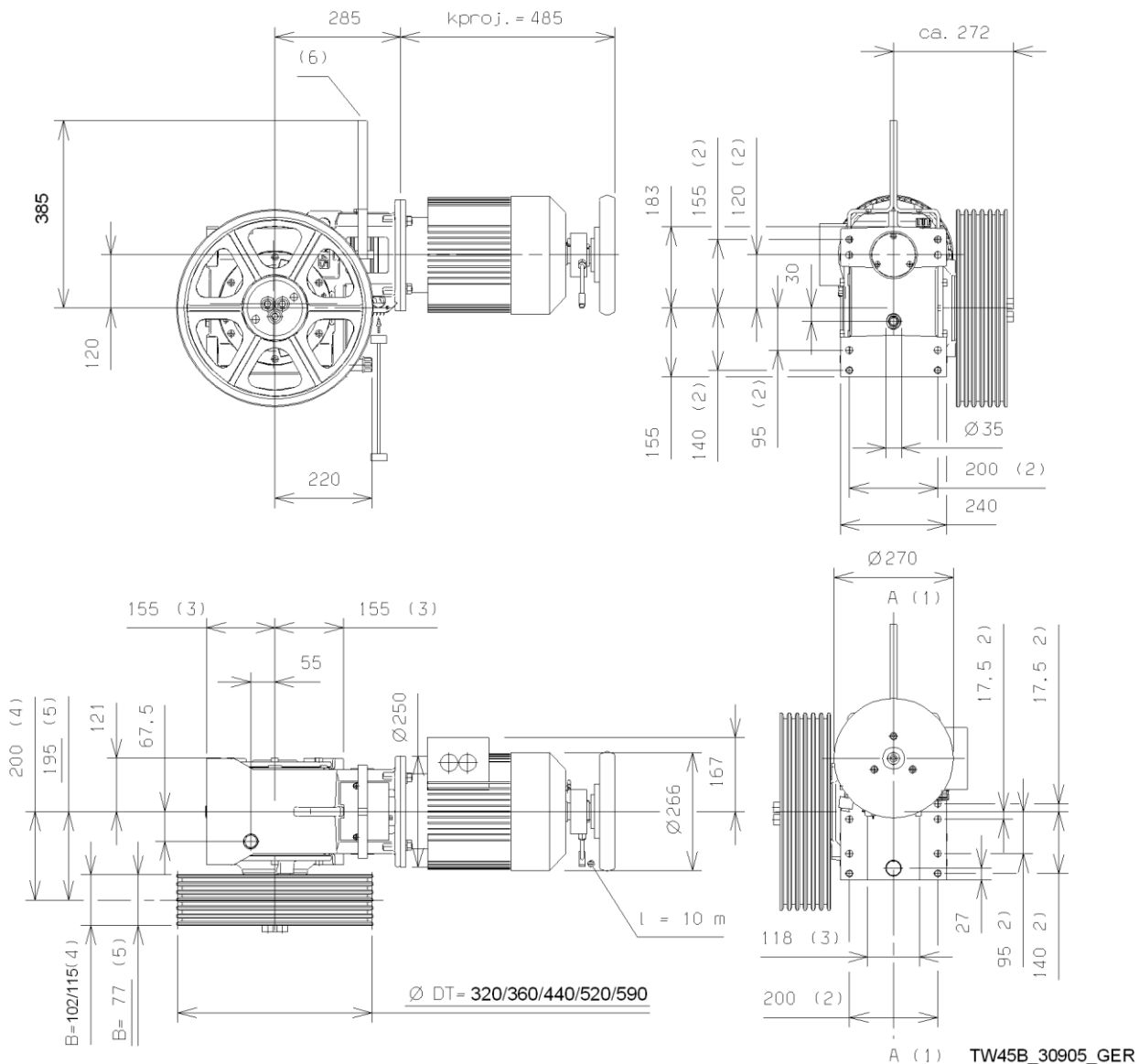
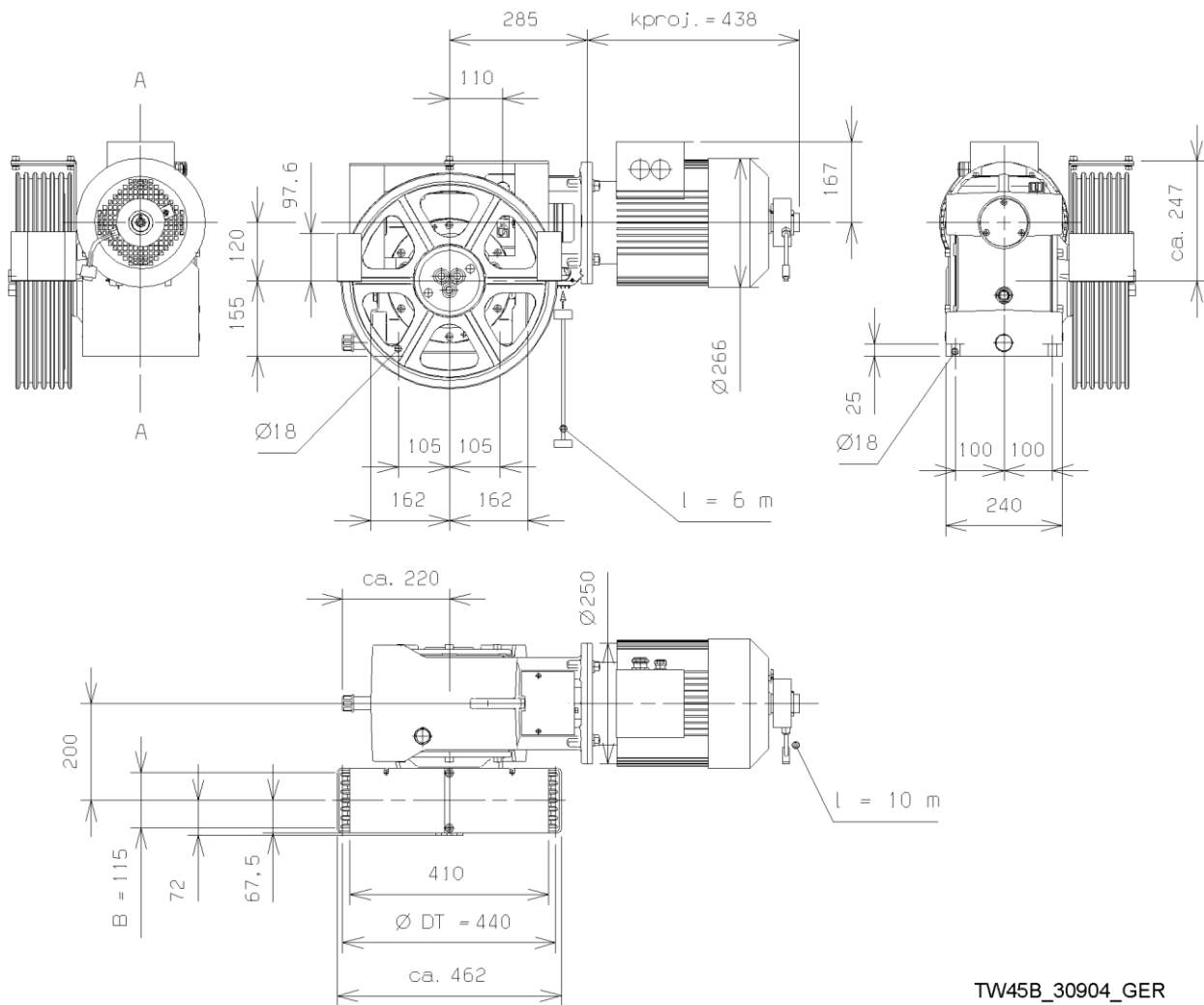

Fig. 3-4: TW45C machine - version for location in shaft pit with flange fixing (e.g. for Simpakt; shown: version with traction sheave position on left)

Description of items for Fig. 3-4

1	Traction sheave position on right, mirror-inverted to A-A	2	Thread M16x25 deep
3	Mounting surfaces - machine base frame	4	with DT = 320 (W=102) / 440 / 520 / 590
5	with DT = 360	6	manual brake release for brake (plug-in)

3.9.5 Version for machine location in the shaft pit (foot mounting)



TW45B_30904_GER

Fig. 3-5: TW45C machine - version for location in shaft pit with foot mounting (e.g. Ecolift; shown: version with traction sheave position on left; on right mirror-inverted to A-A)

3.9.6 Version for machine installation site - machine room with rope departure direction - horizontal

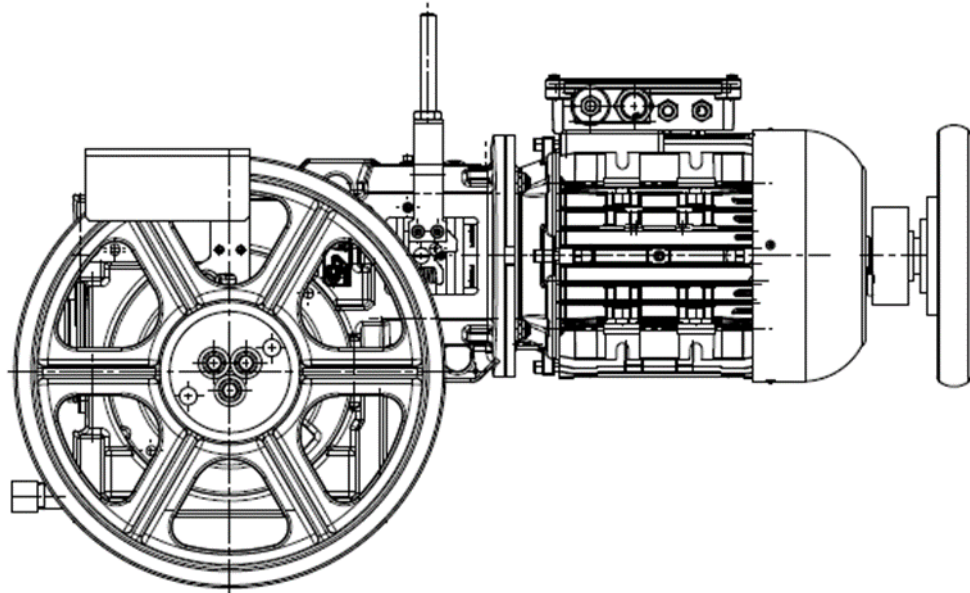

Fig. 3-6: Machine TW45C - Version for installation site - machine room with rope outlet direction - horizontal (shown version with traction sheave position - left and motor position - horizontal)

Adjustment range of the upper rope guard +/- 15° to the horizontal.

3.10 Machine base frame

The machine base frames of the TW45B are used for the TW45C machine.

The machine base frames with / without rope pulley described below are intended for installation of the machine in the machine room above the shaft.

The machine base frame without rope pulley consists of three plated-edge longitudinal brackets with two welded face plates. The hole pattern in the machine base frame permits a shift of the machine on the machine base frame in the modular dimensions 40/50 mm.

The machine base frame with rope pulley consists of the machine base frame without rope pulley as an upper frame part and bolted-on supports for the rope pulley bearings and insulation elements.

With this machine base frame, there is the possibility for a right-hand or left-hand configuration of the rope pulley position with the corresponding installation of the supports.

3.10.1 AY machine base frame TW45B O SR

The machine base frame TW45B O SR in the version without rope pulley is used for:

- Installations with rope suspension 1:1 and direct rope departure with a rope distance elevator car - counterweight $ASL \leq (DT + 100)$ mm with traction sheave dia. 520 or 590 mm
- Installations with rope suspension 2:1 and traction sheave dia. 360, 440, 520 or 590 mm

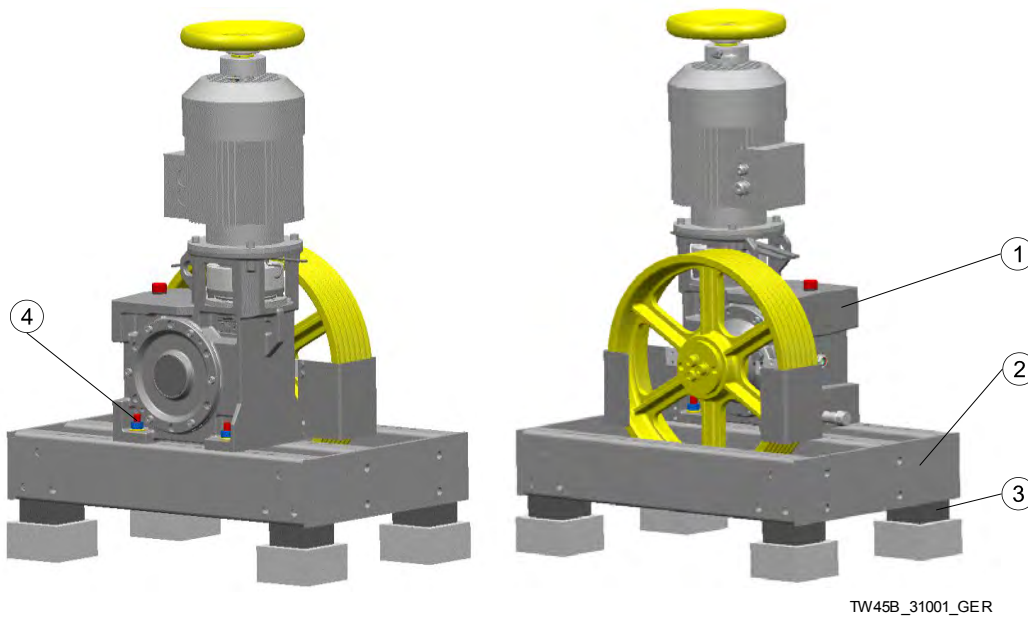

TW45B_31001_GER

Fig. 3-7: TW45B O SR machine base frame (shown with machine in vertical motor position and traction sheave position on left)

Description of items for Fig. 3-7

1	TW45C machine	2	Machine base frame TW45B O SR
3	Insulation elements	4	Mounting parts for machine base frame

Technical data

- Weight of machine base frame: approx. 50 kg

Project planning dimensions

For project planning dimensions, see dimension sheet (Section 3.11.1)

3.10.2 AY machine base frame TW45B M SR

Machine base frame in version with rope pulley depending on the rope pulley position in left-hand or right-hand configuration for use with:

- Installations with rope suspension 1:1 and rope distance elevator car - counterweight ASL = 608 ÷ 833 mm and traction sheave dia. 440 or dia. 520 mm

The rope pulleys that are used are the versions D360-7x dia. 8 (traction sheave with 5/7x dia. 8), dia. 450-7x dia. 10/11 mm (traction sheave with 5x dia. 10/11) or dia. 450-8x dia. 10/11 mm (traction sheave with 6x dia. 10/11). The rope pulleys (versions, see product description mechanical elevator parts 60 720 12 00 0) are designed with maintenance-free rolling bearings.

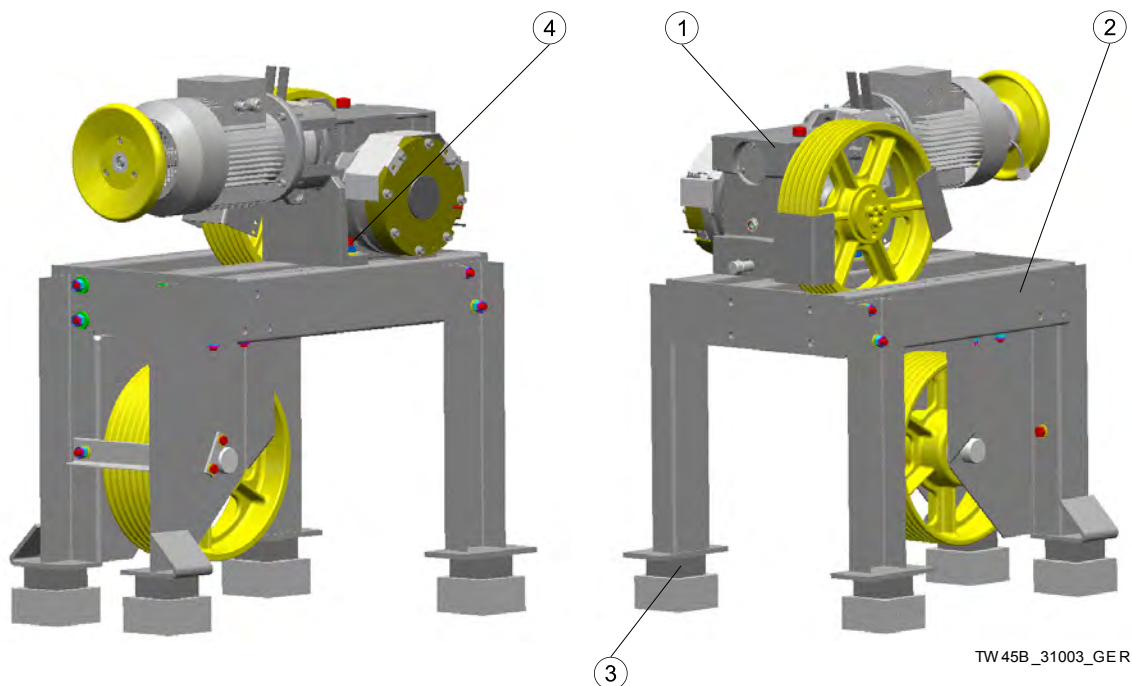

TW45B_31003_GER

Fig. 3-8: TW45B M SR machine base frame (shown: machine base frame in right-hand configuration of the rope pulley with machine in horizontal motor position and traction sheave position on left, incl. emergency brake - NBS)

Description of items for Fig. 3-8

1	TW45C machine	2	Machine base frame TW45B M SR
3	Insulation elements	4	Mounting parts for machine base frame

Technical data

- Weight of machine base frame:

rope pulley version (mm)	m	weight incl. rope pulley
D360	(kg)	140
D450	(kg)	170

TW45B_31004_ENG

Table 3-14: Weight data for M SR machine base frame, project planning dimensions

Project planning dimensions

- Project planning dimensions for the version with rope pulley position on right, see dimension sheet (Section 3.11.2)
- Project planning dimensions for the version with rope pulley position on left, see dimension sheet (Section 3.11.2)

3.10.3 Machine base frame for the machine location in headroom

The TW45C machine is used in the via a special headroom frame.

Suspension plates adapted to the contour of the gear housing (flange fixing) are screw-connected on the face of the machine. Together with the crossbeams, which are also screw-connected, this inner frame unit is mounted via insulation elements in the headroom frame.

A cover plate bolted between the suspension plates serves as a safety device against the risk of falling for the traction sheave and performs the protective functions for the rope entry points.

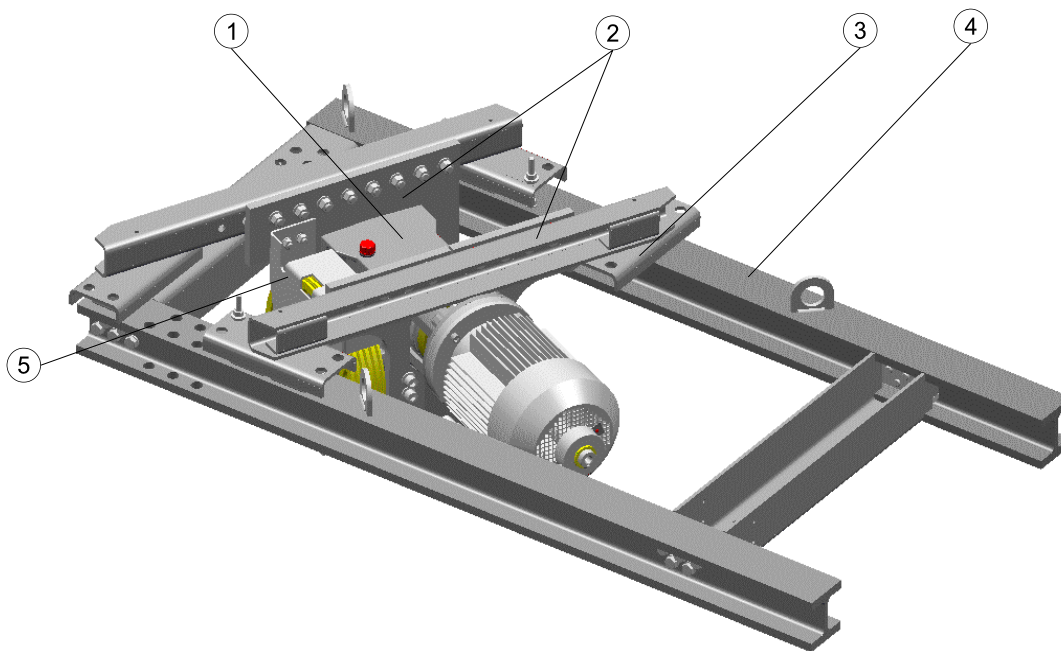

TW45B_31010_GER

Fig. 3-9: Headroom frame (shown with machine in traction sheave position on left)

Description of items for Fig. 3-9

1	TW45C machine - version for location in the headroom	2	Suspension plates with crossbeams
3	Insulation elements	4	Headroom frame (shown without mounting parts)
5	Cover plate for traction sheave		

3.10.4 Mounting parts for machine on machine base frame TW45B

A set of screw connection elements (M16-8.8) is available for mounting the TW45C machine on the machine base frame TW45B O SR / M SR.

3.10.5 Instructions for setting up machine base frames in the machine room

The machine base frames are set up over impact soundproof elements (rubber block 100 x 100 x 50 mm high) in the machine room.

- Insulation elements without support for machine room without floor pavement or erection of machine base frame directly on floor pavement.
- Insulation elements with support for machine room with floor pavement (≤ 60 mm height); support made from Multiplex laminated wood 140 x 140 x 80 mm high.

3.10.6 Version with earthquake safeguard complying with EN81-77

Optional components are available for the TW45B O SR and TW45B M SR base frames; these meet the requirements for protection devices complying with EN81-77.

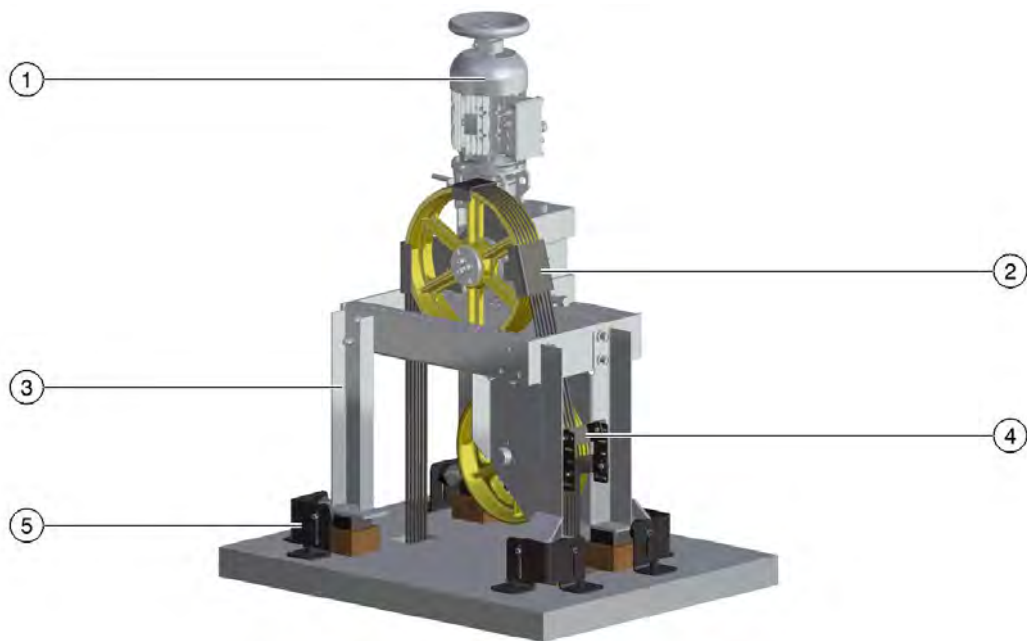

Fig. 3-10: Safeguard measures on AY machine frame unit in accordance with EN 81-77

Description of items for Fig. 3-10 Fig. 3-9 Fig. 3-14

1	TW45C machine, vertical	2	Rope guard complying with EN81-77 for traction sheave
3	Machine base frame TW45B M SR	4	Rope holder complying with EN81-77 for rope pulley dia. D450
5	Shift protection complying with EN81-77		

The safeguard measures are only suitable for machine base frames with locations in the machine room.

The protection device consists of a modified rope guard for rope pulleys dia. D360 or D450 which prevent the ropes departing from the grooves.

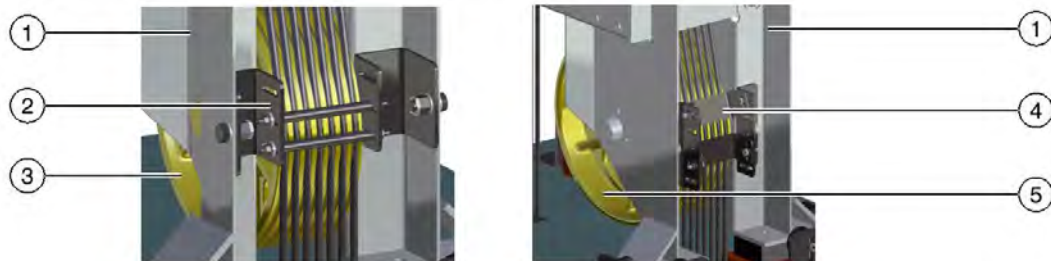

Fig. 3-11: Safeguard measures on AY machine frame unit in accordance with EN 81-77

Description of items for Fig. 3-11

1	Machine base frame TW45B M SR	2	Rope holder complying with EN81-77 for rope pulley dia. D360
3	Rope pulley dia. D360	4	Rope holder complying with EN81-77 for rope pulley dia. D450
5	Rope pulley dia. D450		

The safeguard measures also consist of shift protection devices that prevent the machine from changing its position.

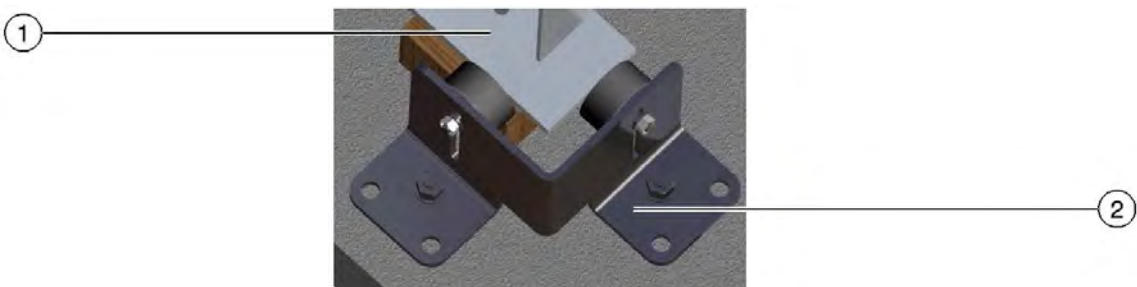

Fig. 3-12: Earthquake safeguard complying with EN81-77 on machine base frame (shown is the shift protection)

Description of items for Fig. 3-12

1	Machine base frame TW45B M SR	2	Shift protection complying with EN81-77
---	-------------------------------	---	---

3.11 Machine base frame dimension sheets

3.11.1 Version of machine base frame without rope pulley

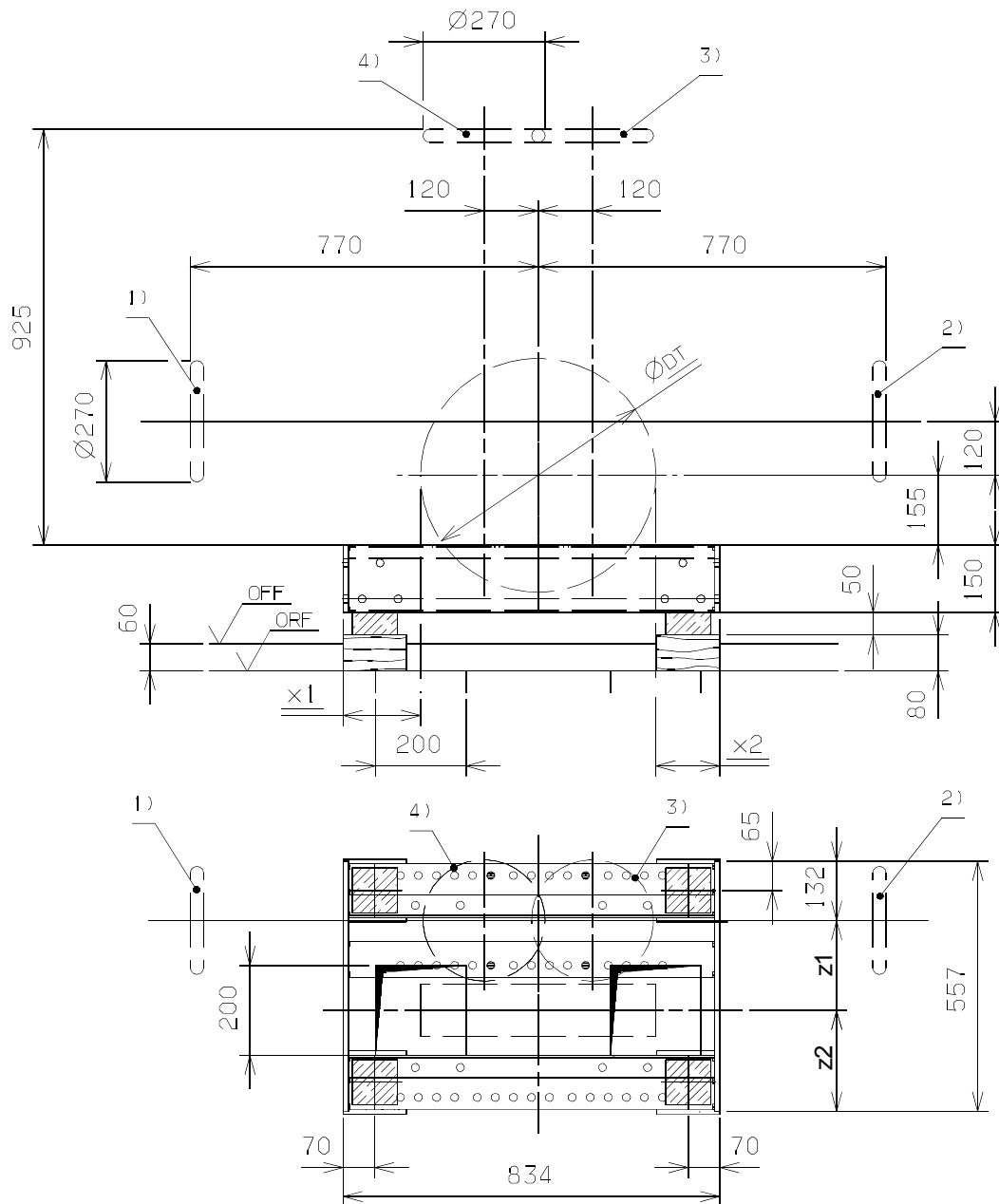

- 1) Machine with horizontal motor position / traction sheave position on right
- 2) Machine with horizontal motor position / traction sheave position on left
- 3) Machine with vertical motor position / traction sheave position on right
- 4) Machine with vertical motor position / traction sheave position on left

TW45B_31007_GER

Fig. 3-13: TW45B machine base frame - version without rope pulley

Project planning dimensions:

Traction sheave version DT (mm)	Unit	Project planning dimension		Machine arrangement			
				left		right	
		z1	z2	x1 _{min}	x1 _{max}	x2 _{min}	x2 _{max}
360	(mm)	195	230	52	412	52	412
440		200	225	52	332	52	332
520				52	252	52	252
590				57	177	57	177

TW45B_31002_ENG

Table 3-15: Project planning dimensions for O SR machine base frame

Intermediate values for x1 and x2 in the modular dimension of 40 mm possible

3.11.2 Version of machine base frame with rope pulley

Project planning dimensions:

- Rope clearance dimensions ASL and wrap angle α

Traction sheave version DT (mm)		Rope pulley version (mm)							
		D360				D450			
		ASL min	α max	ASL max	α min	ASL min	α max	ASL max	α min
440	(mm) / (°)	592	167	832	149	576	168	776	150
520	(mm) / (°)	672			154	616	170		157

TW45B_31005_ENG

Table 3-16: Project planning dimensions for M SR machine base frame

Intermediate values for ASL in the modular dimension of 40 mm possible

- Distances:

rope pulley version (mm)		project planning dimension				
		x1	x2	y1	y2	z1
D360	(mm)	130	61	645	190	245
D450	(mm)	231	116	600	235	255

TW45B_31006_ENG

Table 3-17: Project planning dimensions for M SR machine base frame

Right-hand design of the rope pulley position

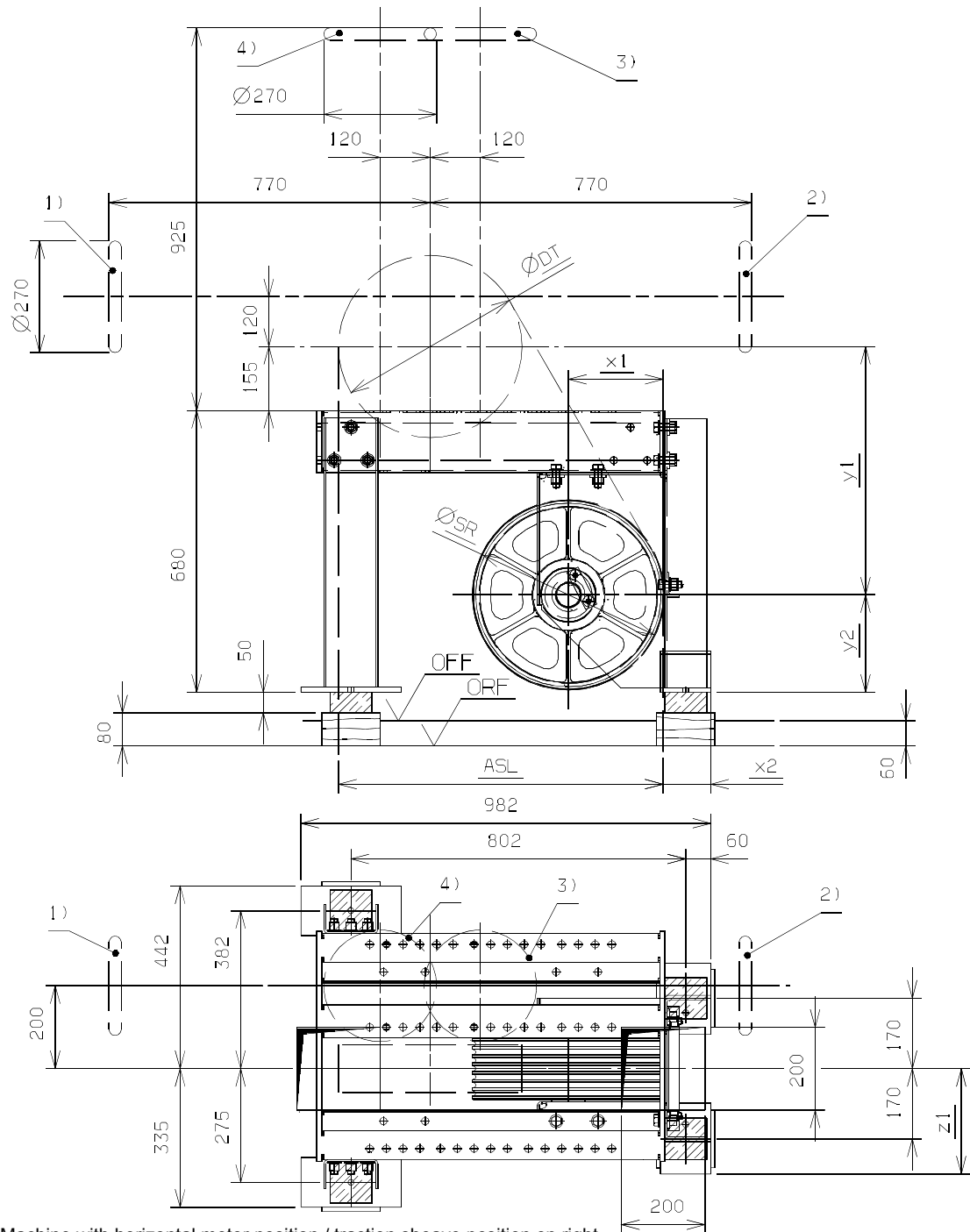

- 1) Machine with horizontal motor position / traction sheave position on right
- 2) Machine with horizontal motor position / traction sheave position on left
- 3) Machine with vertical motor position / traction sheave position on right
- 4) Machine with vertical motor position / traction sheave position on left

TW45B_31008_GER

Fig. 3-14: TW45B M SR machine base frame - version with rope pulley position on right

3.12 Specification and order sheets

The specifications for the machine and the machine base frames are made using SAP parts list:

- Assembly machine TW45C – 6231 000 3843
- Assembly machine frame TW45B – 6231 000 3856

4 Scope of Supply and Packaging

4.1 Scope of supply

4.1.1 Main components

- Driving gear
- Traction sheave
- Motor
- Machine base frame (optional)

4.1.2 Dispatch information

The following variants are possible:

Drive without machine base frame:

The drive is supplied secured on a throw-away pallet to the dispatch department. The machine is packaged ready for dispatch in the dispatch department.

Drive with machine base frame (in subassemblies):

The gear drive and the machine base frame are sent separately to the dispatch department. The subassemblies are packaged ready for dispatch in the dispatch department.

4.1.3 Standard delivery

The standard scope of supply comprises:

- Machine (driving gear including operational brake, motor, traction sheave, handwinding wheel with actual-value sensor)
- Rope guard
- Emergency brake NBS (optional)
- Components for special versions (optional)

4.1.4 Extended scope of supply

- Machine base frame (optionally pre-assembled or in single parts on pallet)
- Operating manual (available the national languages: German, English, French and Russian)
- Blocking clamp
- Insulation elements
- Mounting parts

4.1.5 Delivery period

Product	Delivery period	Can be supplied as of
TW45C (standard version)	6 weeks	Immediately

4.2 Packaging, shipping, storage on the construction site

The drive is secured on a wooden pallet. The associated small parts are included in cardboard boxes/cartons or in packing unit bags.

Unloading by crane or forklift truck is possible.

The drive is secured on a wooden pallet. The associated small parts are included in cardboard boxes/cartons or in packing unit bags.

Unloading by crane or forklift truck is possible.

ThyssenKrupp Aufzugswerke GmbH
Bernhäuser Strasse 45
73765 Neuhausen a. d. F.
Germany

E-mail: Doku.elevator.plant.de@thyssenkrupp.com

Internet: www.thyssenkrupp-elevator-eli.de

Version 03/2019

TW 45 C ,
Linksmaschine

TW 45 C ,
Rechtsmaschine

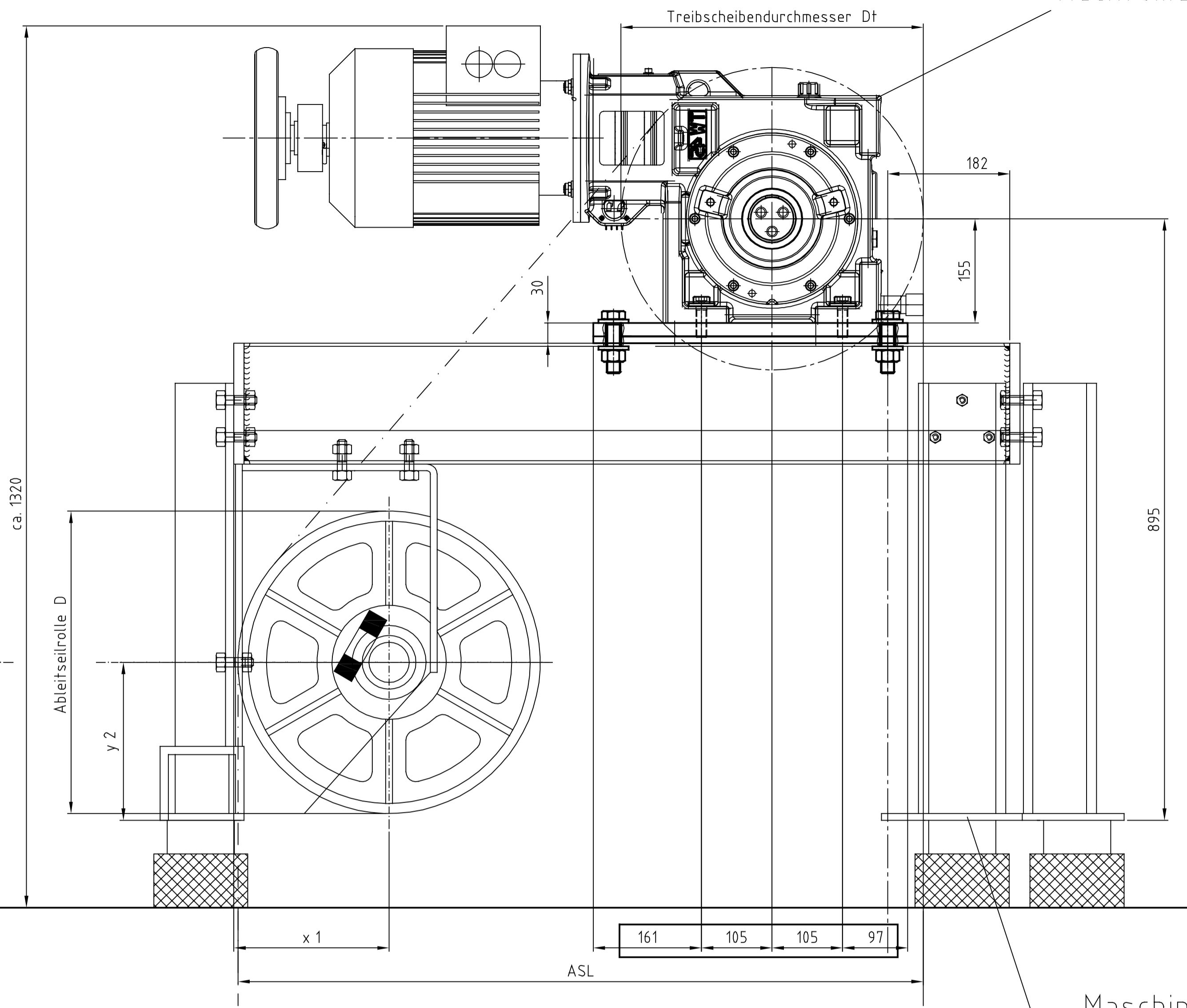
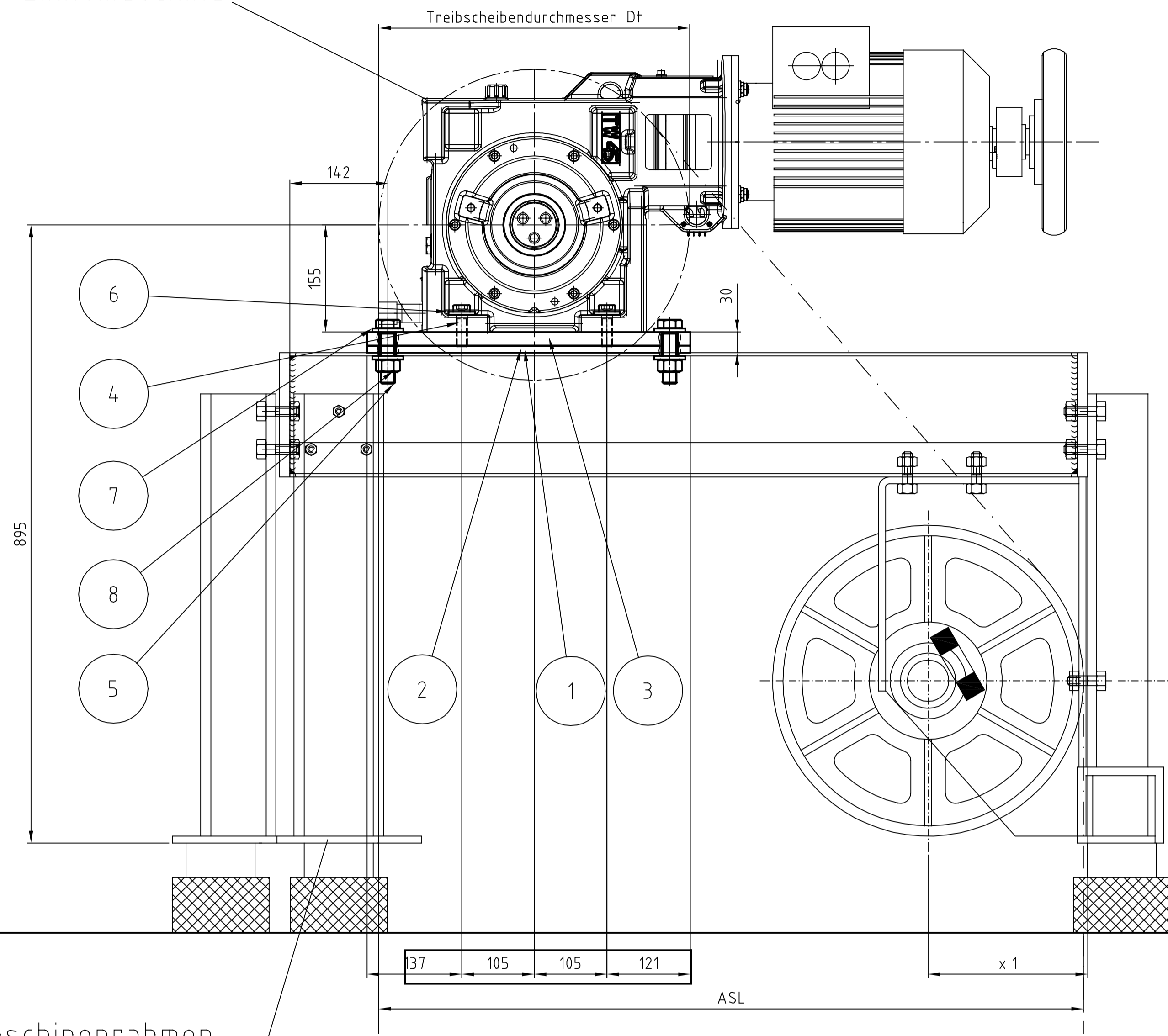

Maschinenrahmen
TW63 -B0/MSR
Seilrollenlage - rechts

Maschinenrahmen
TW63 -B0/MSR
Seilrollenlage - links

Maße x 1 und y2 s. Technikkatalog

Beachtung : Links.- und Rechtsmaschine
haben unterschiedliche Anschraubmaße auf
der Adapterplatte , s.

ASL einstellbar in Stufen von 68 mm z.B. von ASL min. zu ASL max.

Treibscheiben- durchmesser Df	Ableitseilrolle D = 360				Ableitseilrolle D = 450				Ableitseilrolle D = 540			
	ASL min.	Umschlingungs- winkel	ASL max.	Umschlingungs- winkel	ASL min.	Umschlingungs- winkel	ASL max.	Umschlingungs- winkel	ASL min.	Umschlingungs- winkel	ASL max.	Umschlingungs- winkel
320	603	153 °	1011	135 °	-	-	-	-	-	-	-	-
360	623	154 °	1031	136 °	-	-	-	-	-	-	-	-
440	663	156 °	1071	138 °	607	162 °	1015	138 °	-	-	-	-
520	703	159 °	1111	141 °	647	165 °	1055	141 °	647	163 °	1055	139 °
590	738	161 °	1146	143 °	682	167 °	1090	143 °	682	161 °	1090	137 °

hierzu Zchnng. 6232 450 165 7 BL 2

		Oberfläche	Maßstab 1:5	Position	-	Menge	-
	Datum	Name					
	Bearb. 03.07.2012	boettner	ZB.Maschinenrahmen TW 63 mit TW45				
	Gepr.		Anordnungsblatt , ASL varabel				
	Norm		6232 450 165 7				
Zust./Änderungen	Datum	Name	Datenname 6232 450 165 7.dwg				