



Operating instructions

Last updated: 09.2016

Motor unit for sliding gates

Comfort 860 S, 861 S



[E] EASY
[S] OPERATING
SYSTEM

MSBUS 

Marantec 

Table of Contents

1.	General safety instructions	3
1.1	Use for the intended purpose	3
1.2	Target group	3
1.3	Warranty	3
2.	Supply package	4
3.	Gate system	4
3.1	Overview	4
3.2	Gate version	5
4.	Installation	5
4.1	Preparing for installation	5
4.2	Installing the motor unit	7
4.3	Mounting the toothed rack	7
4.4	Adjusting the height of the motor unit	10
4.5	Mounting the reference point magnet	11
4.6	Connection to the control unit	12
5.	Operation	12
5.1	Open the motor unit	12
5.2	Close the motor unit	12
5.3	Hand transmitter	12
5.4	Emergency operation	12
6.	Care and cleaning	13
7.	Maintenance	13
7.1	Maintenance work by the operator	13
7.2	Maintenance work by qualified and trained professionals	13
8.	Disassembly	13
9.	Disposal	13
10.	Rectifying faults	13
11.	Appendix	14
11.1	Technical data	14
11.2	Protection of closing edges	14
11.3	Declaration for the incorporation of a partly completed machine	15

DANGER!

IMPORTANT SAFETY INSTRUCTIONS:

ATTENTION! IT IS VITALLY IMPORTANT FOR THE SAFETY OF PERSONS THAT YOU FOLLOW ALL THE INSTRUCTIONS. KEEP THESE INSTRUCTIONS IN A SAFE PLACE.

IMPORTANT INSTRUCTIONS FOR SAFE INSTALLATION:

ATTENTION! SERIOUS INJURIES CAN BE CAUSED IF THE EQUIPMENT IS NOT INSTALLED CORRECTLY – BE SURE TO FOLLOW ALL THE INSTALLATION INSTRUCTIONS.

Regarding this document

- Original instruction manual.
- Part of the product.
- Read these instructions carefully before use and keep them in a safe place for future reference.
- Protected by copyright.
- No part of this manual may be reproduced without our prior approval.
- Subject to alterations in the interest of technical progress.
- All dimensions are given in millimetres.
- The drawings are not true to scale.

Meaning of symbols

DANGER!

Safety notice indicating a danger that will directly result in death or severe injury.

WARNING!

Safety notice indicating a danger that could result in death or severe injury.

CAUTION!

Safety notice indicating a danger that could result in slight or moderate injuries.

NOTICE

Safety notice indicating a danger that could result in damage to property or in irreparable damage to the product.

CHECK

Reference to a check that needs to be carried out.

REFERENCE

Reference to separate documents that must be observed.

- Instruction requiring action
- List, itemisation
- Reference to other sections of this document
-  Factory settings

1. General safety instructions

DANGER!

Failure to comply with the documentation could result in life-threatening danger!

- Be sure to follow all the safety instructions in this document.

1.1 Use for the intended purpose

- The motor unit is designed exclusively for opening and closing gates.
- Never use the gate to lift persons or objects.

The following applies for the product Comfort 860 S, 861 S:

- The path of the gate must be horizontal, i.e. without any gradient (gate systems with a gradient are special cases and a professional must be consulted).
 - The following data must be complied with:
 - Maximum pulling force
 - Maximum compressive force
 - Maximum gate size
 - Maximum gate weight
- "11.1 Technical data"
- This product is only suitable for sliding gates.

1.2 Target group

- Installation, connection, setting in operation and servicing: Qualified, trained skilled personnel.
- Operation, inspection and servicing: The operator of the gate system.

Requirements to be met by qualified and trained skilled personnel:

- Knowledge of the general and specific safety and accident prevention regulations.
- Knowledge of the relevant electrical regulations.
- Training in the use and care of appropriate safety equipment.
- Adequate instruction and supervision by qualified electricians.
- The ability to recognise hazards that can be caused by electricity.
- Knowledge of the application of the following standards
 - EN 12635 ("Doors and gates - Installation and use"),
 - EN 12453 ("Safety in use of power operated doors - Requirements"),
 - EN 12445 ("Safety in use of power operated doors - Test methods"),
 - EN 13241-1 ("Industrial, commercial and garage doors and gates - Part 1: Products without fire resistance or smoke control characteristics").

Requirements to be met by the operator of the gate system:

- Knowledge and safekeeping of the instruction manual.
- Safe and proper keeping of the inspection logbook.
- Knowledge of general safety and accident-prevention regulations.
- Instruction of all persons who use the door system.
- Ensure that the door system is serviced and maintained periodically by qualified and trained professionals.

Special requirements apply to the following users:

- Children aged eight and above.
 - Persons with reduced physical, sensory or mental capabilities.
 - Persons with a lack of experience and knowledge.
- These users are only authorised to operate the device.
- Special requirements:
- The users must be supervised.
 - The users must have been briefed on how to use the device.
 - The users must understand the dangers involved in handling the device.
 - Children are not allowed to play with the device.

1.3 Warranty

The product is manufactured in accordance with the directives and standards listed in the manufacturer's declaration and in the declaration of conformity.

The product left the factory in perfect working order.

In the following cases, the manufacturer will accept no liability for damage. The warranty for the product and accessory components becomes void in the event of:

- Failure to observe these operating instructions.
- Incorrect handling and use of the product for anything other than its intended purpose.
- Work being carried out by unqualified personnel.
- Changes or modifications to the product.
- The use of replacement parts that have not been approved or were not manufactured by the manufacturer.

The warranty does not cover batteries, rechargeable batteries, fuses and bulbs.





Further safety instructions are given in the relevant sections of this document.



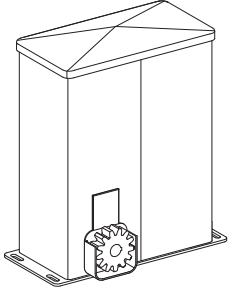
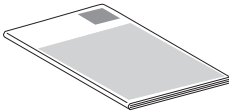

- "4. Installation"
- "5. Operation"
- "6. Care and cleaning"
- "8. Disassembly"

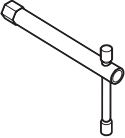
2. Supply package

Regional deviations are possible.

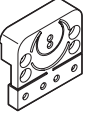
Item	Operator	
1		1x
2		1x

Item	Accessories	
3		4x
4		12x
5		12x
6		1x
7		1x
8		1x

Item	Reference point magnet	
9		1x
10		1x
11		1x
12		2x
13		1x

3. Gate system

3.1 Overview

3.1 / 1

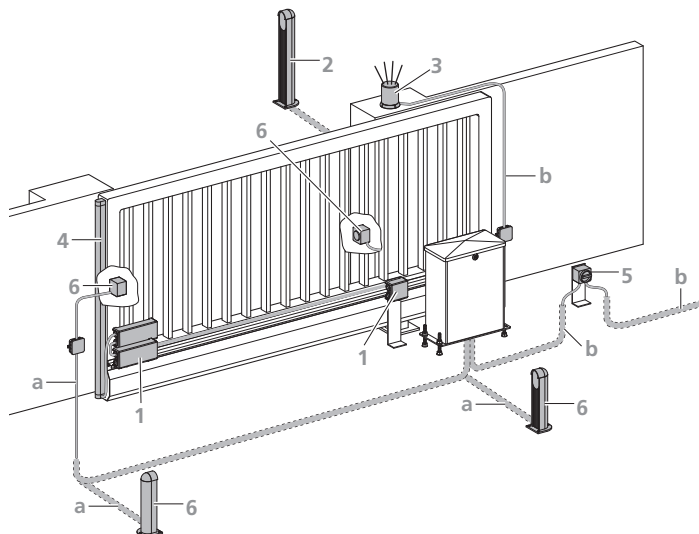

This is just an example of a gate system and can vary depending on the type of gate and the associated equipment. The gate system shown comprises the following components:

- 1 Signal transmission system
- 2 Key switch / code button
- 3 Signal light
- 4 Closing edge safety device (CESD)
- 5 Main switch (mains isolator switch)
- 6 Photocell

Cable cross-sections:

- a 2 x 0.4 mm²
- b 3 x 1.5 mm²

REFERENCE

Further information on accessories can be found on the manufacturer's website.

For the installation and cabling of the gate sensors, control elements and safety equipment, the relevant installation instructions must be observed.

3.2 Gate version

Gate version on rails

3.2 / 1

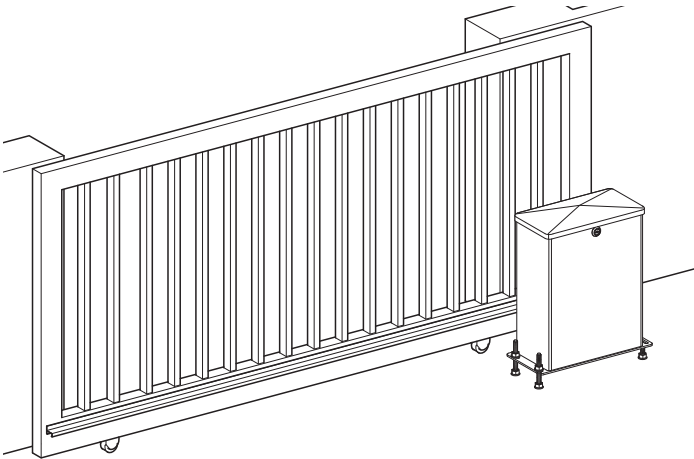

Cantilevered gate version

3.2 / 2

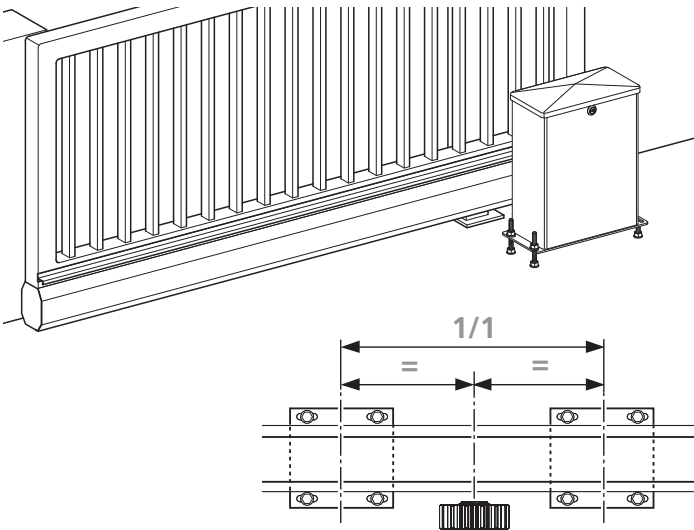

4. Installation

DANGER!

Life-threatening danger due to electric shock!

- It is vital that you disconnect the operator system from the power supply before commencing cabling work. Take measures to ensure that the power supply remains disconnected for the duration of the cabling work.
- Observe the local safety regulations.
- It is imperative that you lay power cables separately from control cables.
The control voltage is 24V DC.

NOTICE

Material damage resulting from incorrect installation of the operator!

To avoid installation errors and damage to the gate and operator system, the following installation instructions must be observed at all costs.

- Ensure that the gate is in good mechanical order:
 - The gate remains stationary in every position.
 - The gate can be moved easily.
 - The gate opens and closes properly.
- When installing the operator system, the gate must be in the closed position.
- Only use fixing materials that are suitable for the foundation material in question.

4.1 Preparing for installation

Before commencing installation, the following works must be carried out without fail.

Supply package

- Check that all the parts are present.
- Check that all the necessary accessory parts for your installation situation are present.

Installation site

The installation site must meet the following conditions:

- There must be sufficient space to allow the motor unit and the toothed rack to be installed on the inside of the gate with the gate closed.
- The motor unit must not extend into the gateway area.
- For cantilevered gates, the motor unit must be mounted at the mid point between the carrier roller assemblies.
→ "3.2 / 2"
- The foundations must be suitable for heavy-duty wall plugs.
- Check whether the existing foundations are suitable.
- Check the routing of the supply cable.
Pay particular attention to the cable exit point where the motor unit is to be installed.
→ "4.1 / 2"

Gate system

- Remove any components from the gate (such as ropes, chains, brackets, etc.) that are no longer needed.
- All equipment that will no longer be required after the gate operator system has been installed must be taken out of service.
- Ensure that a suitable mains connection and a mains isolator switch are available for your gate system.
The minimum cross-section of the earth cable must be $3 \times 1.5 \text{ mm}^2$.
- Ensure that all cables are suitable for outdoor use with respect to UV resistance and cold resistance.
- Check that the gate to be operated fulfils the following conditions:
 - When closed, the gate should extend at least 400 mm further than the clear width on the installation side.
 - The gate must have a mechanical gate stop in both directions.
 - The closing edges must be fitted with a flexible gate seal.

NOTICE

Material damage resulting from incorrect installation of the gate operator!

- The following conditions must be met to prevent the gate and operator systems from being damaged:
- The gate itself must be straight and torsion-free, so that the distance between the motor unit and the gate never changes.
 - The motor must be aligned to face the gate, so that the spur gear can mesh with the toothed rack whatever the position of the gate.
 - The wall plugs for the floor console must be at least 80 mm from the edge of the foundations to prevent the foundations from breaking out.

4.1 / 1

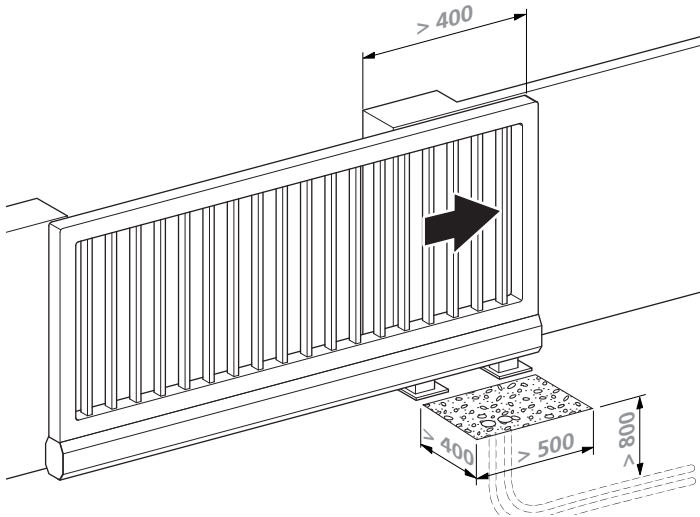

4.1 / 2

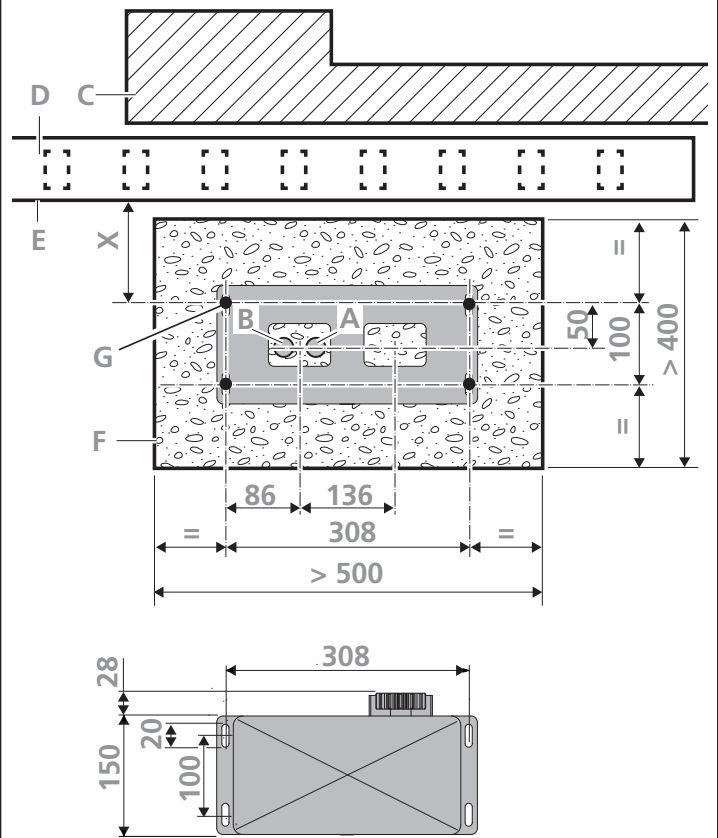

- A Empty conduit for control cable
- B Empty conduit for electricity supply cable
- C Wall
- D Gate
- E Mounting surface for the toothed rack
- F Foundations
- G Front screw fixing point for the motor unit in the ground

- x Distance between the mounting surface (E) and the front screw fixing point for the motor unit in the ground (G).
Special 441: $x = 60$
Special 471: $x = 73$

The installation height must comply with.

→ "4.3 Mounting the toothed rack"

When using an existing toothed rack, the dimension 64 applies from the front wall plug position (G) to the mid point of the toothed rack.

4.2 Installing the motor unit

- Before installing the motor unit, check whether the possible height adjustment of the motor unit is sufficient for the situation on site, or if the motor unit needs to be raised on a backplate.
- Align the motor unit parallel to the gate.
- "4.4 Adjusting the height of the motor unit"
- Drill the holes for the wall plugs as shown in the drill pattern provided.
- Route the control cable and the power supply cable to the installation position.
- "4.1 / 2"
- "5.1 Open the motor unit"

4.2 / 1

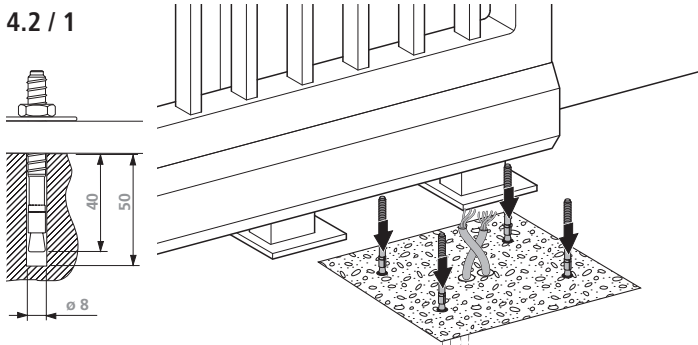

4.2 / 2

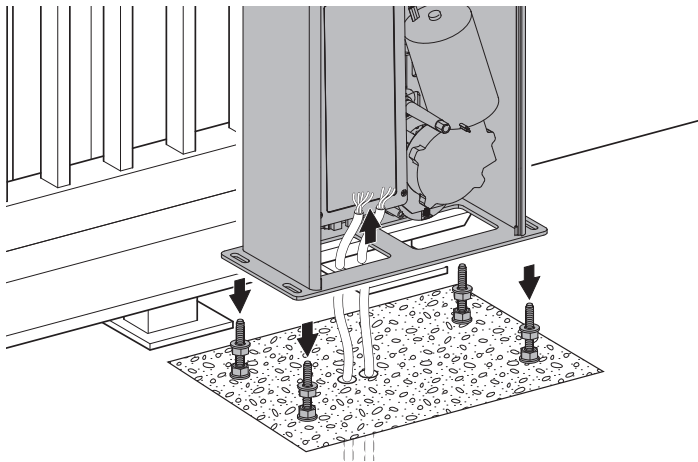

4.2 / 3

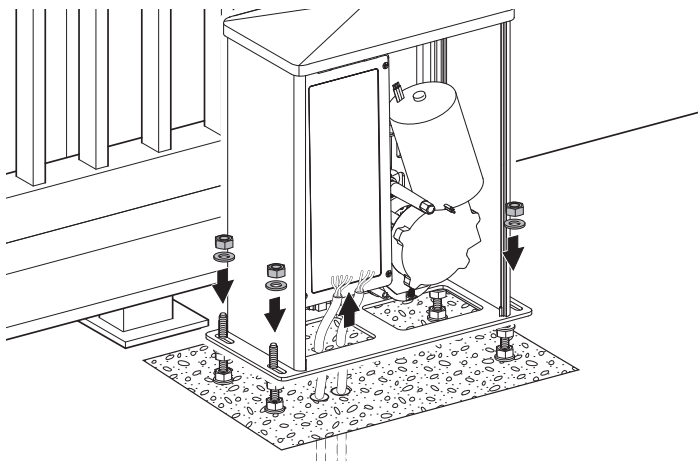

→ "5.2 Close the motor unit"

4.3 Mounting the toothed rack

If the toothed rack has already been mounted, this step is not necessary.

Conditions for mounting:

- The motor unit has been mounted.
- The motor unit is unlocked (released).
- "5.4 Emergency operation"

NOTICE

Material damage due to incorrect installation of the toothed rack!

An incorrectly fitted toothed rack can result in damage to the gate system and the gate operator. To prevent damage:

- Ensure that screws (A) do not obstruct the operation of the gate (e.g. by extending into the path of the gate rollers (B)).
- Ensure that the spur gear (C) is not touching the gate.
- The spur gear (C) should not be at its lowest possible position (it must be possible to lower the spur gear by 1 to 2 mm after the toothed rack assembly has been installed).

4.3 / 1

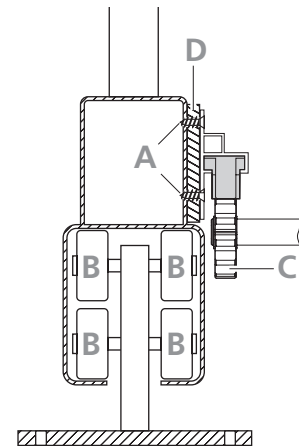

- Determine the installation position of the toothed rack on the gate.
- Adjust the motor unit to the appropriate height.
- "4.4 Adjusting the height of the motor unit"

The toothed rack can be adapted to fit the gate with the aid of a backplate (D).

NOTICE

Malfunctions due to incorrect installation of the toothed rack!

If the length of the toothed rack does not extend out, the gate system can become disengaged from the spur gear in the OPEN and CLOSED positions. It will no longer be possible to operate the gate with the motor.

- Ensure that the toothed rack projects at least 90 mm in the OPEN and CLOSED gate positions.

4.3 / 2

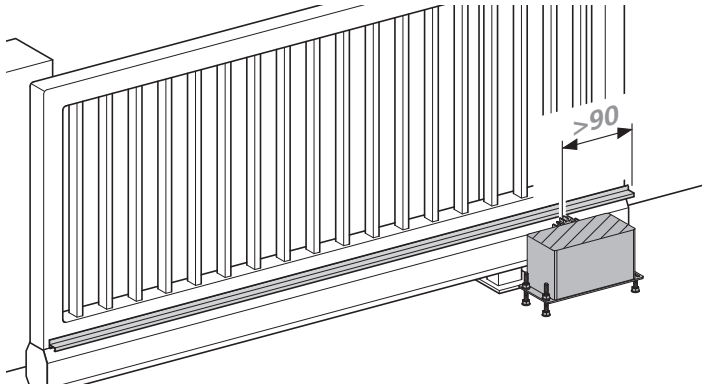

4.3 / 3

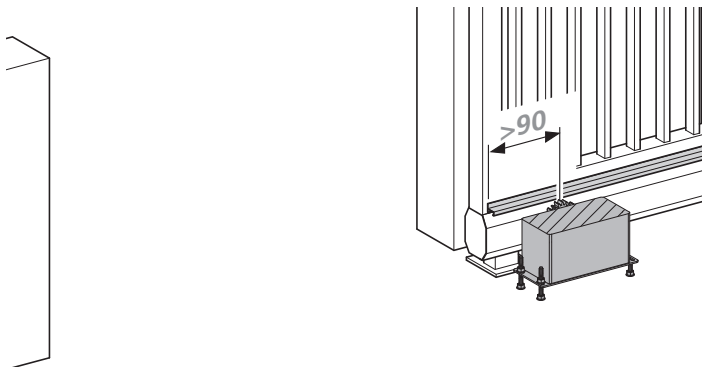

The toothed racks can be supplied in the following standard lengths:

Special 441

- 2,000 mm
- 4,000 mm

Special 471

- 1,020 mm

The toothed racks can be cut to length or slotted together according to requirements.

NOTICE

Material damage due to incorrect installation of the toothed rack segments!

Toothed rack segments in the cover profile could be damaged when the profile is shortened.

To prevent damage to the toothed rack segments:

- Ensure that there are no toothed rack segments at the point to be shortened in the cover profile.

Movable toothed rack segments in the cover profile could be damaged if the gate starts moving.

- Ensure that the assembled segments in the cover profile are prevented from moving.

Special 441

4.3 / 4

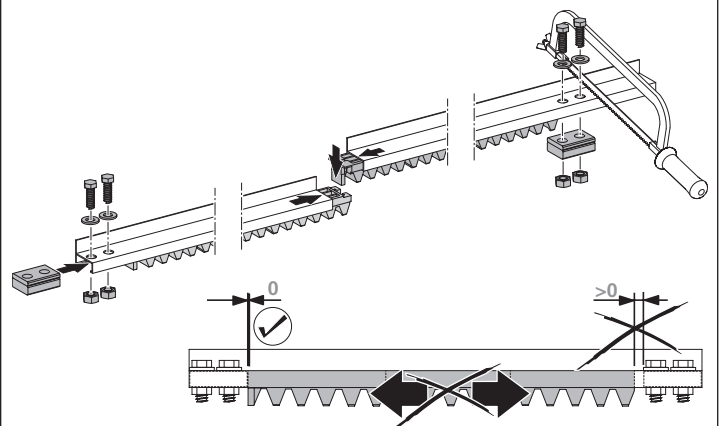

Special 471

4.3 / 5

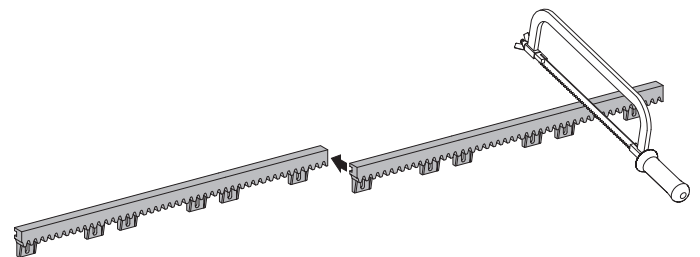

NOTICE

Material damage due to incorrect installation of the toothed rack segments!

Projecting or insufficiently tightened screws could result in the toothed rack jamming during gate movement or being ripped out of the gate.

- Ensure that the pan head screws are tightened and the screw heads are prevented from colliding with the spur gear.

Screw fixing points on the gate

Special 441

4.3 / 6

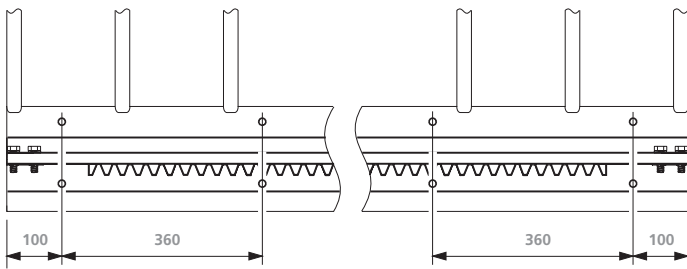

Special 471

Important:

The reference point magnet must be mounted before the rail is fitted.

→ "4.5 Mounting the reference point magnet"

4.3 / 7

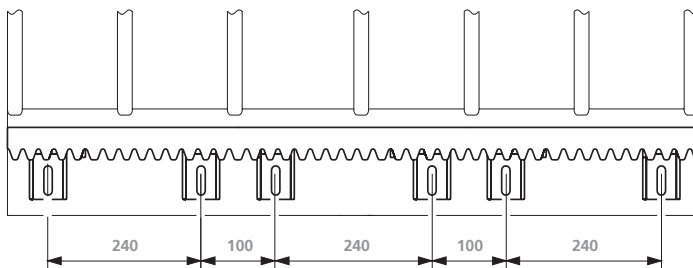

Installation

4.3 / 8

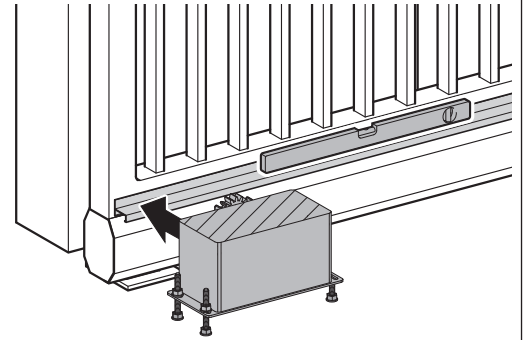

- Lay the toothed rack onto the spur gear so that the toothed rack meshes with the spur gear.
- Align the toothed rack horizontally.
- Clamp the toothed rack to the other side with a clamp to hold it in place.
- Screw the toothed rack to the gate at the first screw fixing point, in accordance with the relevant drill pattern.
- Remove the clamp.
- Keep the toothed rack pressed against the spur gear every time you close the gate a bit further.

4.3 / 9

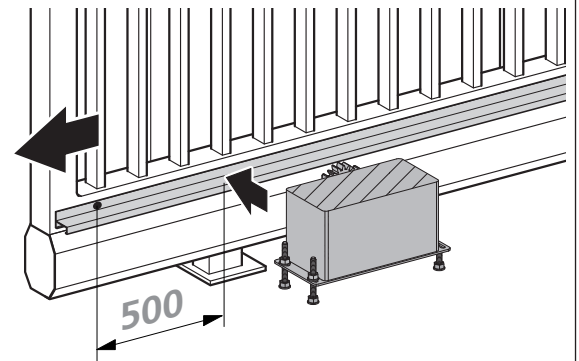

4.3 / 10

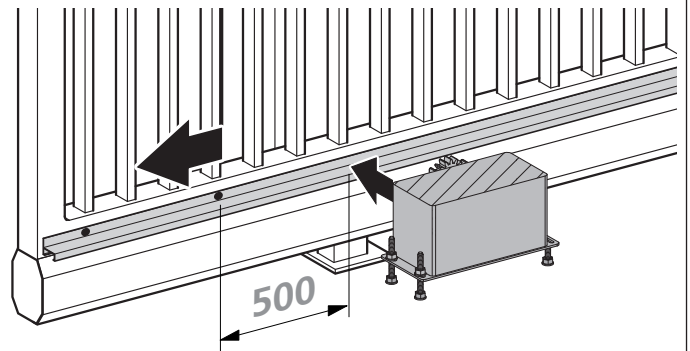

4.3 / 11

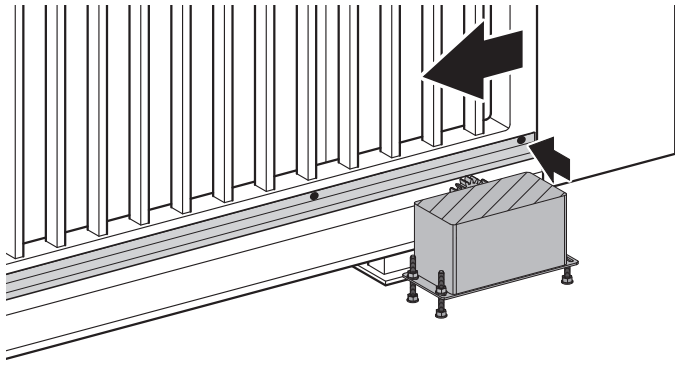

- Close the gate 500 mm further at a time.
- Screw the toothed rack to each closed gate section in turn, as shown on the relevant drill pattern.

NOTICE

Malfunctions due to incorrect installation of the toothed rack!

If the adjustment between the toothed rack and the spur gear is too tight, the operator system could jam and become damaged during gate movement.

- Ensure that a clearance of 1 to 2 mm is maintained between the toothed rack and the spur gear.

4.3 / 12

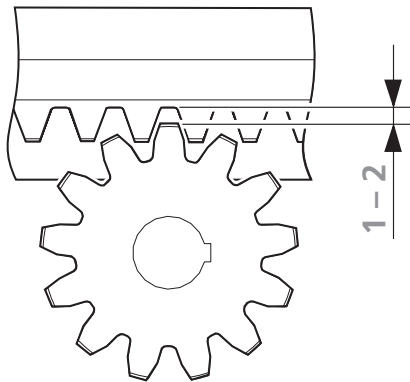

- Lower the motor unit by 1 to 2 mm.
- "4.4 Adjusting the height of the motor unit"

CHECK

A functional check must be carried out to ensure that the toothed rack is engaged with the spur gear along its entire length:

- Ensure that the gate operator is unlocked (released).
- "5.4 Emergency operation"
- Move the gate slowly by hand into the OPEN and CLOSED end positions.
- The spur gear must be propelled by the movement of the gate.

4.4 Adjusting the height of the motor unit

4.4.1 Adjusting the height of the housing

4.4.1 / 1

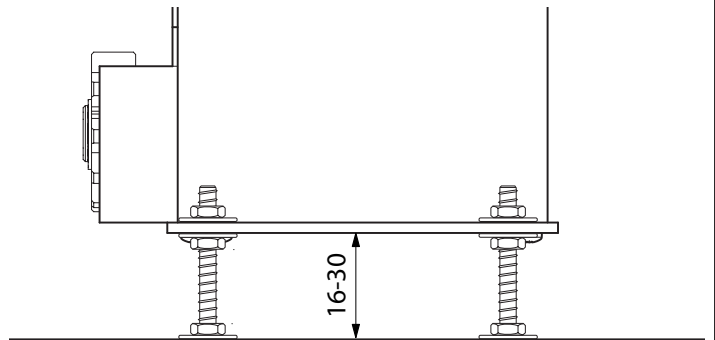

The height of the motor unit can be adjusted using the heavy-duty wall plugs.

4.4.2 Adjusting the height of the spur gear

In order to adjust the height of the spur gear, first loosen the screws (A).

Once the height has been adjusted, the screws (A) must be retightened.
→ "5.1 Open the motor unit"

4.4.2 / 1

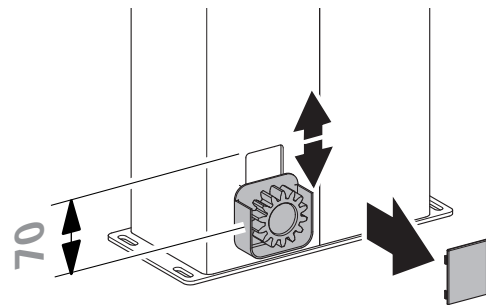

4.4.2 / 2

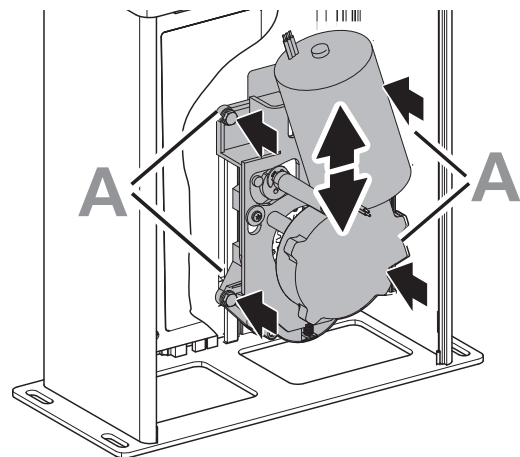

4.4.2 / 3

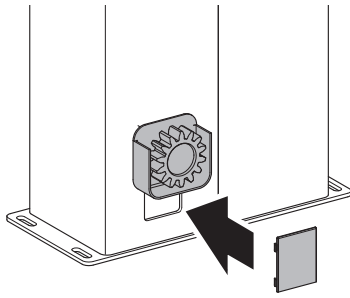

4.4.2 / 4

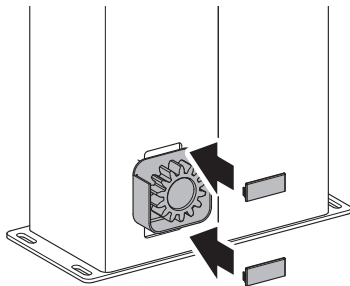

→ "5.2 Close the motor unit"

4.5 Mounting the reference point magnet

WARNING!

Danger of injury due to uncontrolled movement of the gate!

To avoid injury, the gate must have a mechanical end stop in both directions; otherwise it could spring out of line.

The operator system determines the extent of travel and the gate positions electronically. To do so, it requires a reference point on the gate or the toothed rack. A special reference point magnet is used as the reference point.

NOTICE

Malfunctions due to incorrect installation of the reference point magnet!

Measuring the gate operator reference point can be interfered with or prevented by the presence of old magnets and incorrect installation clearances. To prevent faults:

- Remove any existing magnets (e.g. in the case of retrofit measures with an existing toothed rack).
- Ensure that there is a distance between the reference point magnet (A) and the motor unit (B) of 2-8 mm.
- The distance between the centre of the magnet (A) and the centre of the spur gear (C) must be 70 mm.

4.5 / 1

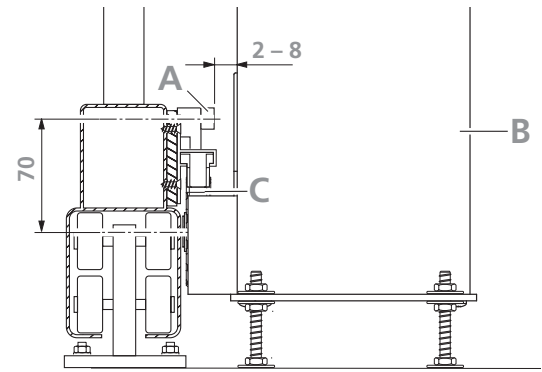

4.5 / 2

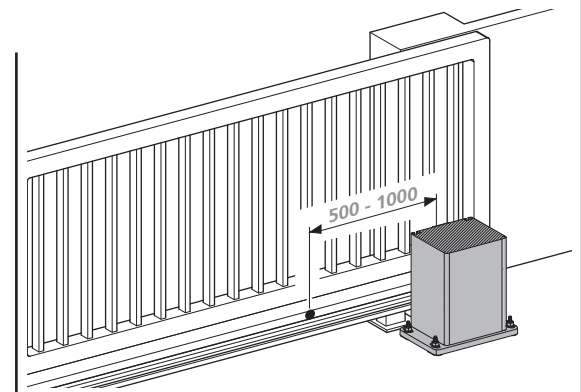

- Move the gate to the CLOSED position.
- Determine the position for the reference point magnet.

The reference point magnet is mounted differently depending on the type of toothed rack used.

Special 441

4.5 / 3

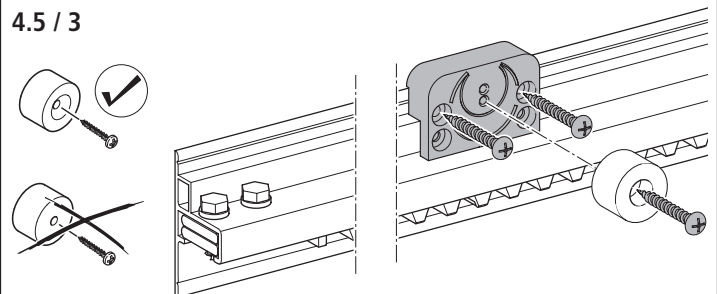

Special 471

4.5 / 4

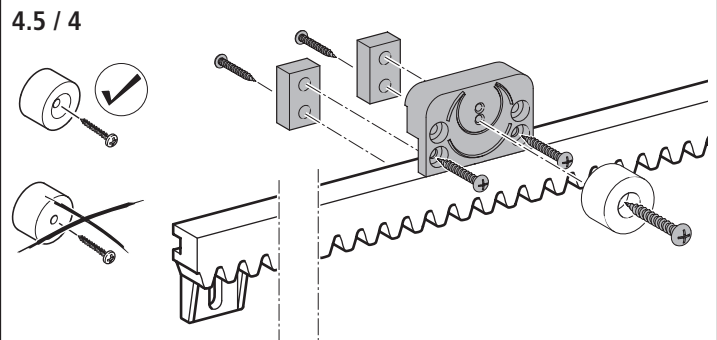

4.6 Connection to the control unit

REFERENCE

Follow the instructions in the relevant documentation when connecting the operator to the control unit.

5. Operation

5.1 Open the motor unit

5.1 / 1

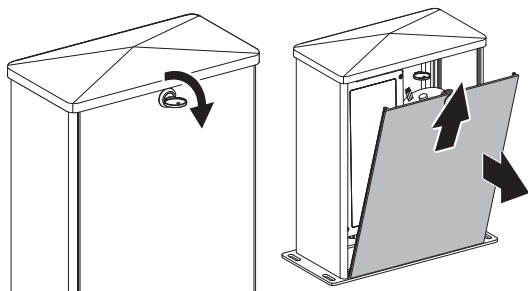

5.2 Close the motor unit

5.2 / 1

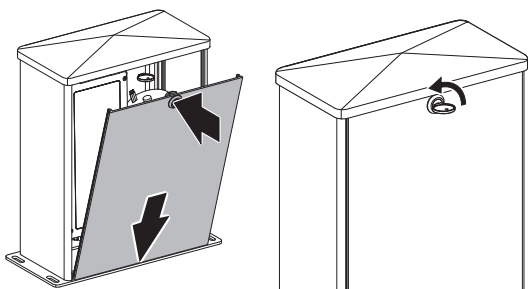

5.3 Hand transmitter

REFERENCE

Follow the instructions in the relevant documentation for operation with a hand transmitter.

5.4 Emergency operation

NOTICE

Malfunctions due to incorrect handling!

If the gate is not locked in the position in which it was released, the reference point monitoring will no longer work correctly.

- Ensure that the gate is locked in the position in which it was released.

→ "5.1 Open the motor unit"

5.4 / 1

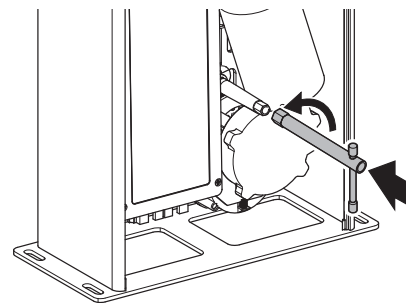

5.4 / 2

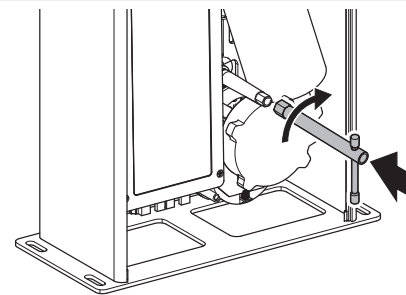

→ "5.2 Close the motor unit"

6. Care and cleaning

DANGER!

Life-threatening danger due to electric shock!

- It is vital that you disconnect the operator system from the power supply before cleaning. Take measures to ensure that the power supply remains disconnected for the duration of the cleaning operation.

NOTICE

Damage resulting from incorrect operation!

When cleaning the operator system, never use: direct water jets, high pressure cleaners, acids or alkaline solutions.

- Clean the outside of the housing using a damp, soft cloth that does not shed fibres.

If particularly dirty, the housing can be cleaned using a mild detergent.

7. Maintenance

7.1 Maintenance work by the operator

Damage or wear to a door system must only be rectified by qualified and trained professionals.

To ensure fault-free operation, the gate system must be inspected regularly and, if necessary, be repaired. Before starting work on the gate system, the operator system must always be disconnected from the power supply.

- Check once a month that the operator system reverses when the gate touches an obstacle. Place an obstacle in the path of the gate to check this.
- Check all the moving parts of the gate system and gate operator system.
- Check the gate system for signs of damage or wear and tear.
- Move the gate manually to check that the gate travels easily and smoothly.
- Check that the photocell functions properly.
- Check that the closing edge safety device functions properly.
- Check the power supply cable for signs of damage.
For safety reasons, if the power supply cable is damaged it must be replaced by the manufacturer or his customer service department, or by a similarly qualified person.

7.2 Maintenance work by qualified and trained professionals

Power-operated windows, doors and gates must be inspected by qualified and trained professionals whenever necessary, but at least once a year (written inspection records must be kept).

- Test the driving power with a force tester designed for this purpose.
- Replace any damaged or worn parts.

8. Disassembly

DANGER!

Life-threatening danger due to electric shock!

- It is vital that you disconnect the operator system from the power supply before commencing dismantling work. Take measures to ensure that the power supply remains disconnected for the duration of the dismantling work.

WARNING!

Possibility of serious injury due to incorrect dismantling!

- Comply with all applicable occupational health and safety regulations.

The system must be dismantled by qualified and trained professionals, following the installation instructions in reverse order.

9. Disposal

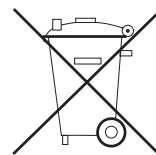

Do not dispose of old equipment or batteries with the normal household waste!

- Dispose of old devices at a waste collection centre for electronic waste or via your specialist dealer.
- Dispose of old batteries in a battery recycling container or via a specialist dealer.
- Dispose of the packaging material in the special waste collection containers for paper, cardboard and plastic.

10. Rectifying faults

REFERENCE

To rectify faults, follow the instructions in the control unit documentation.

11. Appendix

11.1 Technical data

Electrical data

Voltage rating, regional deviations are possible	V	230 / 260
Rated frequency	Hz	50 / 60
Power consumption in operation*	kW	0,4
Power consumption in standby*	W	ca. 3.2
Duty cycle	min	KB 5
Control voltage	V DC	24
Protection category of motor unit		IP 44
Protection class		I

* without any additional equipment connected

Mechanical data

Max. push and pull force		
– Comfort 860 S	N	400
– Comfort 861 S	N	800
Max. travel speed	mm/s	200
Opening time, dependent on gate type	s	20–25

Environmental data

Dimensions of motor unit

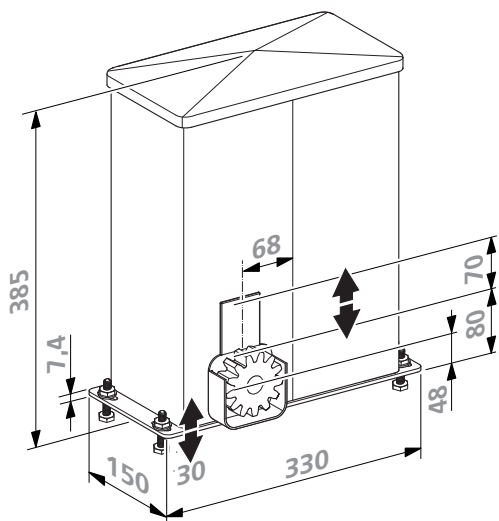

Weight		
– Comfort 860 S	kg	12.5
– Comfort 861 S	kg	14.5
Sound pressure level	dB(A)	< 70

Environmental data

Temperature range		°C	-20
		°C	+60

Use

Comfort

860 S 861 S

Sliding gates			
– Max. gate width	mm	8,000	8,000
– Max. gate weight	kg	400	800

11.2 Protection of closing edges

Weight of gate (kg)	Rubber profile		Speed	
	Main closing edge	Secondary closing edge	Normal run	Soft run
400	A	B	100 mm/s	100 mm/s
	C	C	140 mm/s	140 mm/s
	D	D	185 mm/s	100 mm/s
	E	E	245 mm/s	160 mm/s
800	C	C	–	–
	D	D	110 mm/s	110 mm/s
	D	E	115 mm/s	75 mm/s
	E	E	190 mm/s	95 mm/s

- A 1K-36H-Ind1 passive / art. no.: 78078
- B 1K-36H-Ind1 passive / art. no.: 78079
- C 2K-58H Ind 1B passive / art. no.: 63823
- D Protect – Contact 700 / art. no.: 104620
(only cut to length/assembled)
- E Protect – Contact 800 / art. no.: 104622
(only cut to length/assembled)

Cutting to length/assembly

for Protect-Contact 700:

- Cutting to length/assembly of flow strip / art. no. 115079
- Cutting to length/assembly of end strip / art. no. 115078

for Protect-Contact 800:

- Cutting to length/assembly of flow strip / art. no. 115081
- Cutting to length/assembly of end strip / art. no. 115080

11.3 Declaration for the incorporation of a partly completed machine

(Declaration of Incorporation in line with EC Machinery Directive 2006/42/EC in accordance with Annex II, Part 1 B)

Manufacturer:

Marantec Antriebs und Steuerungstechnik GmbH & Co. KG,
Remser Brook 11, 33428 Marienfeld, Germany

The partly completed machine (product):

Comfort 860 S, 861 S Sliding Gate Operator
Revision status: R01

has been developed, designed and manufactured in accordance with the:

- EU Machinery Directive 2006/42/EC
- EU RoHS Directive 2011/65/EU
- EU Low Voltage Directive 2014/35/EU
- EU Electromagnetic Compatibility Directive 2014/30/EU
- Radio Equipment Directive (RED) 2014/53/EU

Applied and referenced standards and specifications:

- EN ISO 13849-1, PL "c", Cat. 2
Safety of machinery - Safety-related parts of control systems - Part 1: General principles for design
- EN 60335-2-103
Household and similar electrical appliances – Safety – Part 2-103: Particular requirements for drives for gates, doors and windows.
- EN 61000-6-3/2
Electromagnetic compatibility – Emitted interference and immunity

The following requirements of EC Directive 2006/42/EC were complied with:

General principles, No. 1.1.2, 1.1.3, 1.1.5, 1.1.6, 1.2.1, 1.2.2, 1.2.3, 1.2.6, 1.3.1, 1.3.4, 1.3.7, 1.3.8, 1.3.9, 1.4.1, 1.4.3, 1.5.1, 1.5.4, 1.5.6, 1.5.8, 1.5.14, 1.7

Furthermore, we declare that the special technical documentation for this partly completed machine was prepared in accordance with Annex VII Part B and we undertake to supply these documents, in electronic form, to the national authorities in response to a duly reasoned request.

This partly completed machine is intended only for installation in a door system, in order to create a complete machine pursuant to Machinery Directive 2006/42/EC. The door system may not be set in operation until it has been ascertained that the complete system complies with the requirements of the above-mentioned EC directives.

This declaration shall no longer be valid if changes are made to the product without our authorisation.

Authorised agent for the preparation of the technical documentation:
Marantec Antriebs- und Steuerungstechnik GmbH & Co. KG,
Remser Brook 11 · 33428 Marienfeld · Germany
Fon +49 (5247) 705-0



Marienfeld, 1 February 2016

M. Hörmann
Director



Identification plate, motor unit

Type A _____

Rev (B) _____

Art. No. (C) _____

Prod. No. (GB) _____

