

25 Years of Manufacturing Excellence

# Zeta<sup>®</sup>

ALARM SYSTEMS



# simplicity CO

Addressable Carbon Monoxide Detection,  
Monitoring & Ventilation System

# Introduction

## Description of Carbon Monoxide CO

Carbon Monoxide is a colourless, odourless, flammable toxic gas. It is a chemical asphyxiant and acts toxically by combining with haemoglobin in the red blood cells to form the stable compound carbon monoxide-haemoglobin. If inhaled, concentrations of 0.4% in the air can prove fatal in less than one (1) hour, while inhalation of high concentration can cause sudden collapse with little or no warning.

CO Concentration	Symptoms	Inhalation Time
0.02% (200 ppm)	Light headache	2-3 hours
0.04% (400 ppm)	Front headache	1-2 hours
	Severe headache/Dizziness	2-3 hours
0.08% (800 ppm)	Nausea/Convulsions	45 minutes
	Fainting	2 hours
0.16% (1600 ppm)	Headache/Nausea	20 minutes
	Death	2 hours
0.32% (3200 ppm)	Headache/Nausea	10-15 minutes
	Death	30 minutes
0.64% (6400 ppm)	Headache/Nausea	1-3 minutes
	Death	10-15 minutes

## How is CO Generated?

Carbon Monoxide is a by-product of combustion. Any fuel burning appliance, vehicle, tool or other device has the potential to produce dangerous levels of Carbon Monoxide.

The AirCO<sub>n</sub> 8 system is designed to detect & monitor CO concentrations in places such as warehouses, car parks, tunnels and enclosed buildings where forklifts, cars and delivery trucks can produce deadly amounts of carbon monoxide, in high traffic areas Carbon Monoxide can accumulate in these areas and can be a serious safety and health concern.

## What is the Simplicity CO

The Simplicity CO system was designed to be simple to use addressable carbon monoxide detection and ventilation system, capable of detecting low concentrations of CO, and automatically starting the building's ventilation fans. Its features include:-

- ✓ True analogue addressable system
- ✓ Economical 2 wire installation
- ✓ Can view the PPM reading of every detector
- ✓ Each detector can be given a 20 character label to ease device identification (optional).
- ✓ Loop of 126 devices divided into 8 zones
- ✓ Continuously displays the maximum reading in each zone
- ✓ Option for 2 ventilation relays per zone, for systems with 2 speed fans
- ✓ Zonal or common ventilation options
- ✓ Easy to use ventilation level selection
- ✓ Battery backup enables the system to give an alarm warning in the case of mains power failure
- ✓ System "programming" is determined by detector & relay address settings
- ✓ Suitable for small and large installations
- ✓ Designed & Manufactured in the UK
- ✓ Meets latest low voltage directive
- ✓ CE marked

# Simplicity CO

## Addressable CO Monitoring & Ventilation Control Panel



The Simplicity CO system is a self conditioned controller with a capacity to handle up to 110 CO monitors which are divided to 8 monitoring zones.

Each Zone will permanently display on the Liquid Crystal Display (LCD) the highest concentration of CO in that zone in PPM (Particles Per Million). This monitored value is updated every 10 seconds. The system will allow up to 2 interface modules (ZIOU/I-230) which are programmed to initiate a signal to Ventilation equipments to operate at pre-determined levels of concentration. Should the CO concentration keep rising while the Ventilation is still on, an alarm is raised at a pre-determined level.

The Simplicity CO system is ideal for:

- ✓ Underground car parking facilities
- ✓ Warehouses where non-electric fork lift & vehicles are used
- ✓ Tunnels
- ✓ Factories
- ✓ Boiler Rooms etc.

Model	S32/CO	S64/CO	S126/CO
Part No	37-167	37-168	37-169
Capacity	32 Devices	64 Devices	126 Devices
Mains Voltage	230 +/-10% VAC, 50-60 Hz		
System Voltage	24 Vdc + 9V Communication (Nominal)		
Power Supply	2 Amp PSU		
Wiring	Radial (8 zones) or 1 Loop Selectable		
Alarm Output	2 x 150mA @ 24 Vdc		
Panel Size (mm)	370(W) x 311(H) x 113(D)		
Space for Batteries	Up to 2 x 7.0 AH SLA Batteries		
Weight	4Kg		

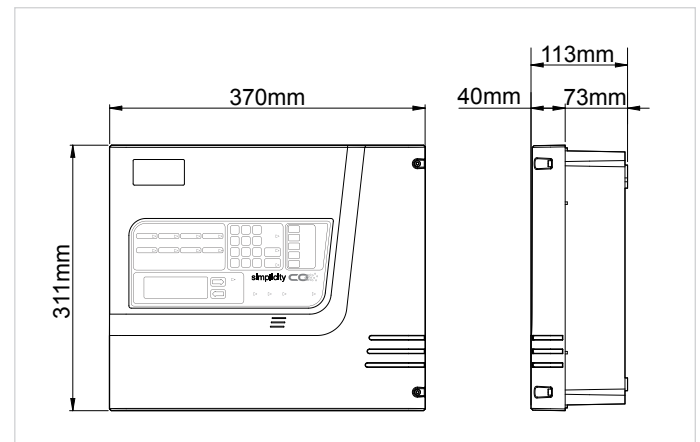

### ZIOU/I-230

The ZIOU/I-230 Mains IO Modules are fully monitored loop powered devices which permit the interfacing of ventilation equipment with the Simplicity CO Control Panel using normally open dry contact connections.

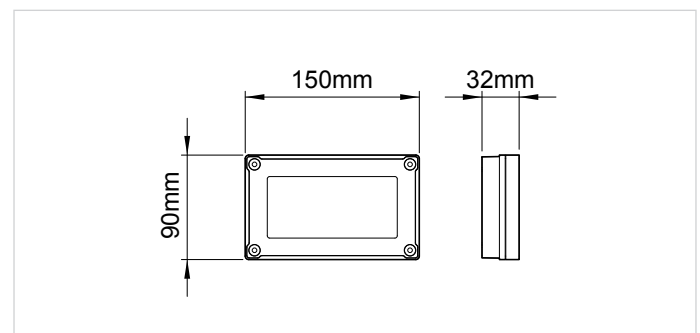
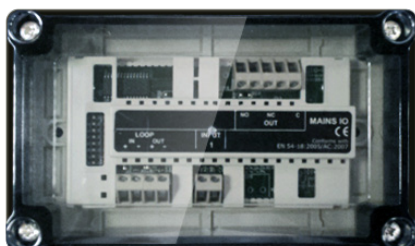

# CO800N

## Addressable Carbon Monoxide Detector



The CO800N is an analogue addressable Carbon Monoxide detector specifically designed for use with the Simplicity CO addressable carbon monoxide monitoring & ventilation panel

The detector uses an electro-chemical sensor with the detection range of 0 to 600 ppm of carbon monoxide. The detectors address is set via a binary dipswitch on the rear of the detector.

The optimum mounting height for this detector is between 1.5 & 2m from the floor.

Model	CO800N
Part No	47-015
Operating Voltage	17-28 Vdc
Standby Current	500 $\mu$ A @ 24 Vdc
Operating Temperatures	-20°C to +60°C
Max Humidity	95% RH no condensation
Max Wind Speed	Not effected
Ingress Protection	IP43
Coverage	300m <sup>2</sup>
Sensor / Range	Electro-chemical / 0-600 ppm
Sensor Lifetime	5 years maximum

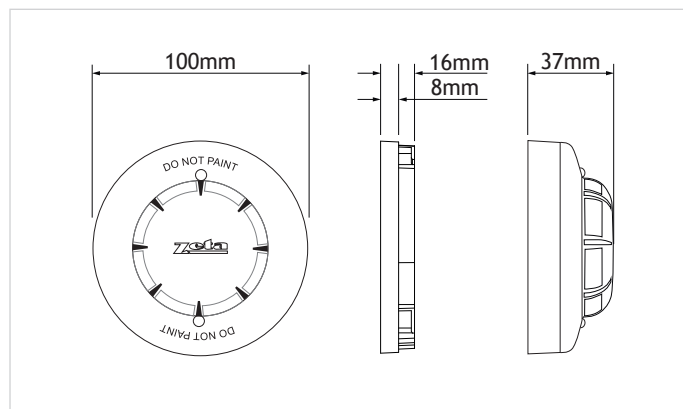

### Test Cannister

In order to achieve safe testing of the CO detectors, the solo CO canister with the dispenser can introduce CO safely to the sensor from outside, demonstrating free flow from the atmosphere to the sensor.

The CO contained within the Solo canister is at a level which poses no threat to the user when used correctly.



# Simplicity CO - Typical Wiring

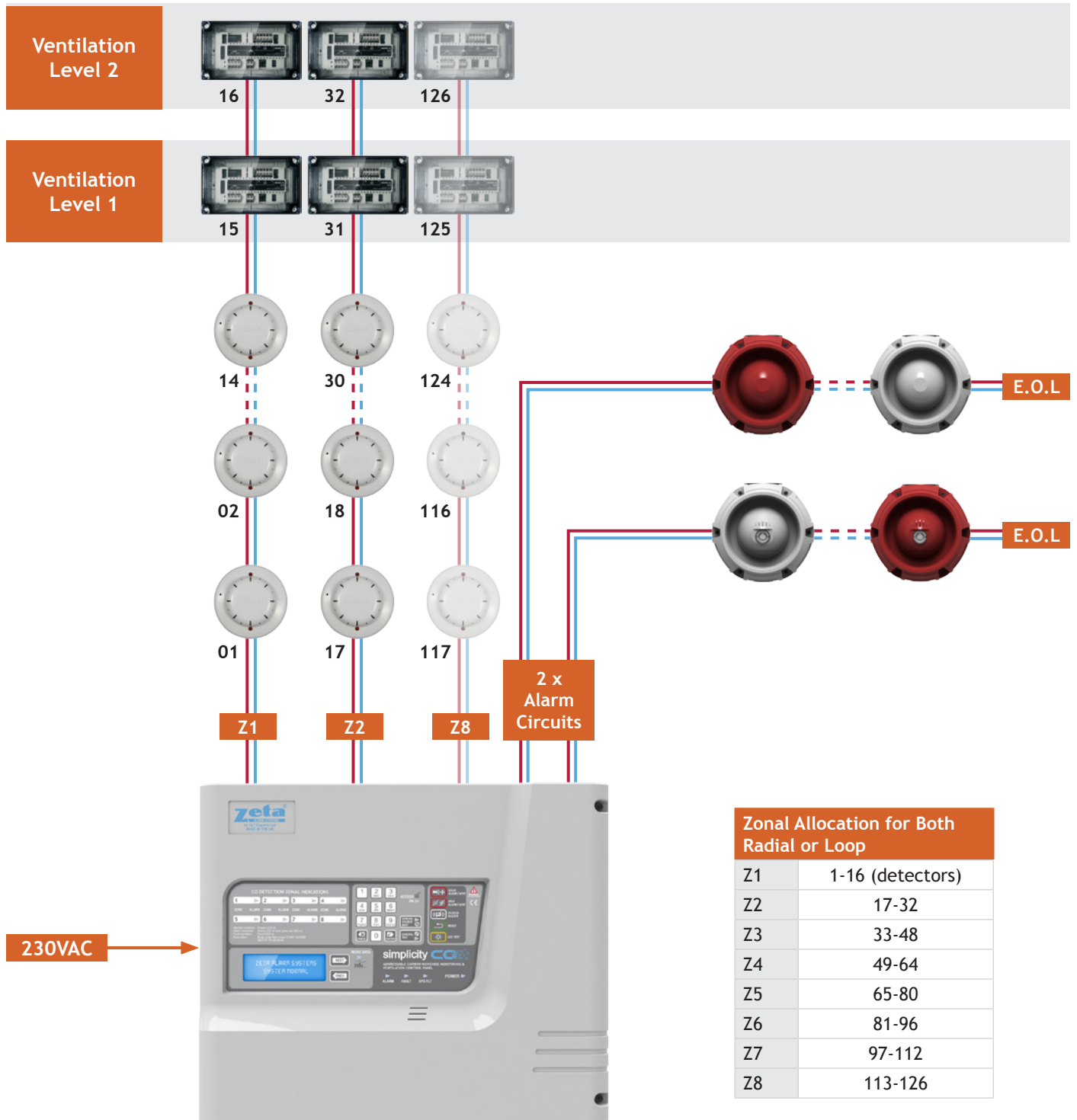

# Simplicity CO Product Range

	Model	Part No	Description
	S32/CO	37-167	Simplicity CO 32 Addr. CO Panel, 2 Zone, 32 Device
	S64/CO	37-168	Simplicity CO 64 Addr. CO Panel, 4 Zone, 64 Device
	S126/CO	37-169	Simplicity CO 126 Addr. CO Panel, 8 Zone, 126 Device
	CO800N	47-015	Analogue Addressable CO monitor c/w mounting base
	ZIOU/I-230	48-125	Interface module, loop powered provides a set of voltage free contacts (5.0A Rating)
	ZRP/R	42-630	Conventional Raptor Sounder, Red
	ZRP/W	42-631	Conventional Raptor Sounder, White
	ZRPB/R	42-632	Conventional Raptor Sounder Beacon, Red plastic, White Flash
	ZRPB/W	42-633	Conventional Raptor Sounder Beacon, White plastic, White Flash
	Solo - CO	25-013	CO test Canister
	Solo - 330	48-415	CO dispenser
	Solo - 100	48-400	6m Test Pole

Available now from:



Assessed to ISO 9001: 2008  
Certificate number 330

Tel: +44 (0) 1792 455 175

Fax: +44 (0) 1792 455 176

Detection House  
72-78 Morfa Road  
Swansea  
SA1 2EN  
United Kingdom

**GLT Exports Ltd**  
MANUFACTURERS OF FIRE ALARM EQUIPMENT

Email: [info@zetaalarmsystems.com](mailto:info@zetaalarmsystems.com)  
Web: [www.zetaalarmsystems.com](http://www.zetaalarmsystems.com)