



Underground Fire Hydrant Squat Type

Product Description

The Series 29/388 is a squat fire hydrant suitable for use with water and neutral liquids, to a maximum temperature of 70°C. Complies with requirements of BS 750 and BS EN1074-2:2000 and EN 14339:2005, underground hydrants. Also to BS EN 1074-6 for potable (drinking) water.

Working Pressure

Max Working Pressure: 16bar (232 psi)

Standards

- Designed according to BS750:2012, Designed according to EN 1074 part 1 & 2, Designed according to EN 14339:2005
- WIMES 8.09 Compliant

Test and Approvals

- Hydraulic test to BS 750, Seat: 1.1 x PN. Body: 1.5 x PN. Operating torque test
- Resistance to operating load - MOT - 105NM - MST - 210NM
- Kitemarked to BS750
- WRAS approved for cold water use
- Drinking Water Inspectorate Regulation 31 compliant

Features

- Inlet flange universally drilled to EN1092-2 PN10/16 and BS10 Table D/E.
- BS 750 Type 2c. Screwed - down type with screwed 2½" round thread outlet.
- Complies with Annex ZA of BS EN 14339 in respect of Construction Products Directive (CPR)(EU) 305/2011.
- Temperature Range: -10°C to +70°C, Insulation essential for temperatures of 0°C and below.
- Fully maintainable.
- Low weight design.
- 2½" London round thread outlet to BS 750.
- Exceeds flow requirements: Kv = 92 minimum 2000l/min @1.7 bar. Actual: Kv = 96, 2092 l/min @1.7 bar.
- Auto-frost drain valve as standard
- Fixed stopper.
- Corrosion resistant construction, ductile iron coated with WRAS approved epoxy coating Blue RAL 5017, to 250 microns min. Holiday free in accordance with WIS 04-52-01, compliant with BS EN 1074-6 for disinfection products.
- Note: It is recommended that applications in a corrosive atmosphere or sited in exposed locations use a stainless steel stem 1.4404 (316) and all exposed fasteners in A4 stainless steel.

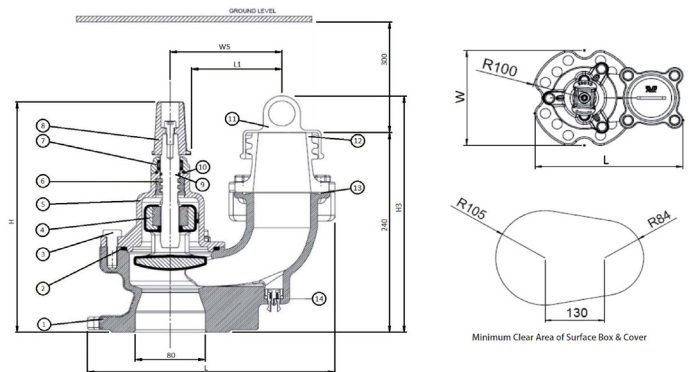

Material Specification

Part No	Description	Materials
1	Body	Ductile iron GJS-500-7 (GGG-50)
2	Body Bonnet Seal	NBR rubber
3	Fasteners	Stainless steel A2
4	Stopper Assem.	Ductile iron GJS-500-7 (GGG-50)
5	Bonnet	Ductile iron GJS-500-7 (GGG-50)
6	Thrust Collar	Brass, DZR CW602N
7	Gland Flange Assem.	Ductile iron GJS-500-7 (GGG-50)
8	Stem Cap	Ductile iron GJS-500-7 (GGG-50)
9	Stem	Stainless steel 1.4021
10	Gland Flange Seal	NBR rubber
11	Dust Cap	PE
12	Outlet	Stainless steel 1.4021
13	Body Outlet Seal	NBR rubber
14	Auto Frost Valve	Nylon 6.6, Body and plunger with NBR WRAS approved O-rings and stainless steel spring to DIN17224

Dimensions

Size	H mm	H3 mm	L mm	L1 mm	W mm	W5 mm	Weight kg	Ordering Code
DN80	278	284	283	102	190	127	13	RDBS750SQ

Manufactured by AVK Aqua-Gas Manufacturing who hold the WRAS & Kitemark Certificates

DS: 12.07
Issue A
05/12/2019
© 2019 Rapidrop

Rapidrop Global Ltd
T: +44 (0) 1733 847 510 F: +44 (0) 1733 553 958
e: rapidrop@rapidrop.com
w: www.rapidrop.com