

CAF/CADF series



Features

- Able to be applied to various applications with 4-way mounting.
- Easy maintenance due to easy rod separation.

Symbol
Double Acting / Single Rod
Single Acting / Spring Return

How to Order

CAF - A 10 - S 20 [] [] [] []
 ① ② ③ ④ ⑤ ⑥ ⑦ ⑧

① Series

CAF	Without magnet
CADF	Built-in magnet

② Mount type

A	Through-hole type
B	Lateral mounting type
S	Axial mounting type

- ※ A: Bore size Ø10
- ※ B, S: Bore size Ø12, Ø16, Ø20

③ Bore size

	Bore size
4	Ø4(developing)
6	Ø6(developing)
8	Ø8(developing)
10	Ø10
12	Ø12
16	Ø16
20	Ø20(developing)

④ Stroke(mm)

Bore size	Standard stroke	
	Double Acting	Single Acting / Spring Return
Ø10	4,6,8,10,15 20,25,30	4,6,8,10
Ø12	5,10,15,20	5,10
Ø16	25,30	

⑤ Action

Nil	Double Acting
S	Single Acting Spring Return

⑥ Rod end thread

Nil	Rod end female thread
N	Rod end male thread

⑦ Auto switch

Reed	Model	Solid state	Model
A-90(V)	D-A90(V)K	F-9N(V)	D-F9N(V)K
A-93(V)	D-A93(V)K	F-9P(V)	D-F9P(V)K
A-93N	D-A93KN	F-9B(V)	D-F9B(V)K
A-93S	D-A93(V)K-S	F-9N(V)S	D-F9N(V)K-S
		F-9P(V)S	D-F9P(V)K-S
		F-9B(V)S	D-F9B(V)K-S

- ※ Only for auto switch attached type.
- ※ Refer to Auto Switch Catalogue for more information.

⑧ Number of auto switches

Nil	2 pcs
S	1 pc
N	N pcs (N: 3, 4, 5...)

- ※ Only for auto switch attached type.



Specifications

Bore size		Ø4	Ø6	Ø8	Ø10	Ø12	Ø16	Ø20	
Action		Double Acting / Single Acting Spring Return							
Fluid		Compressed Air							
Proof pressure		10.7kgf/cm ² (1.05MPa)							
Max. operating pressure		7.1kgf/cm ² (0.7MPa)							
Min. operating pressure	Double Acting	1.5kgf/cm ² (0.15MPa)			1kgf/cm ² (0.1MPa)	0.7kgf/cm ² (0.07MPa)		0.5kgf/cm ² (0.05MPa)	
	Single Acting Spring Return	2kgf/cm ² (0.2MPa)	2kgf/cm ² (0.2MPa)		2kgf/cm ² (0.2MPa)	2.5kgf/cm ² (0.25MPa)		1.8kgf/cm ² (0.18MPa)	
Ambient & fluid temperature		-10℃ ~ 70℃(Without magnet) -10℃ ~ 60℃(Built-in magnet)							
Operating piston speed		50~500mm/sec							
Cushion		None					Rubber cushion		
Lubrication		Not required							
Tolerance of stroke		+0.5 0					+1.0 0		
Mounting		Through-hole type					CAFB: Through-hole type (Lateral, axial direction: 2 locations each) CAFS: Through-hole type (Axial direction: 2 locations)		

Mass

Double Acting

Unit: g

Bore size	Stroke(mm)													Additional weight	
	4	5	6	8	10	15	20	25	30	35	40	45	50	Built-in magnet	Rod end male threaded
Ø4	7.2	-	7.9	8.6	9.3	11.1	12.8	-	-	-	-	-	-	-	0.4
Ø6	12.4	-	13.6	14.8	16.0	18.9	21.8	24.7	27.6	-	-	-	-	2.7	0.8
Ø8	15.6	-	17.0	18.4	19.7	23.0	26.4	29.9	33.4	-	-	-	-	3.0	1.5
Ø10	17.9	-	19.4	20.8	22.3	25.9	38.5	33.1	36.7	-	-	-	-	3.2	2.6
Ø12	-	20	-	-	26	32	38	44	50	-	-	-	-	6	4
Ø16	-	32	-	-	39	46	53	60	67	-	-	-	-	9	8
Ø20	-	52	-	-	62	72	82	92	102	112	122	132	142	12	13

Single Acting

Unit: g

Bore size	Stroke(mm)					Additional weight	
	4	5	6	8	10	Built-in magnet	Rod end male threaded
Ø4	7.2	-	7.9	-	-	-	0.4
Ø6	12.8	-	14.0	15.2	-	2.7	0.8
Ø8	15.8	-	17.2	18.6	19.9	3.0	1.5
Ø10	17.9	-	19.4	20.8	22.3	3.2	2.6
Ø12	-	23	-	-	28	6	4
Ø16	-	34	-	-	41	9	8
Ø20	-	53	-	-	63	12	13

Structure

Bore size Ø10

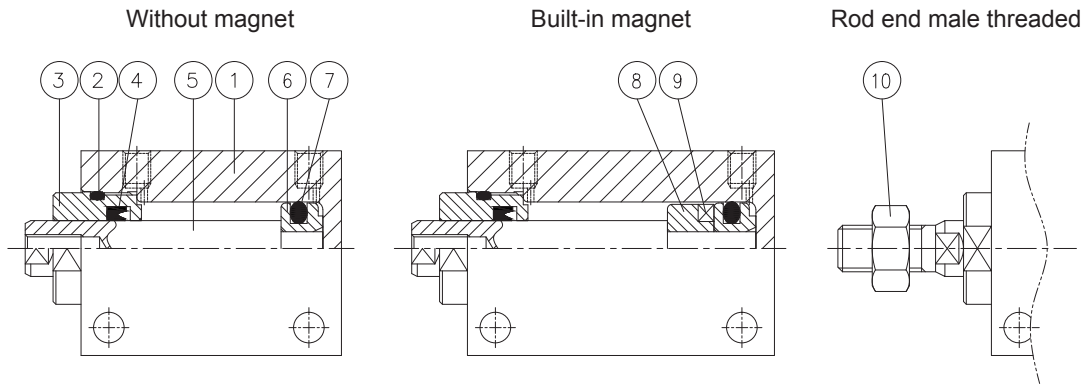

No	Parts	Material	Remark
1	Cylinder tube	Aluminum alloy	Hard anodized
2	Tube O-ring	NBR	-
3	Rod cover	Copper alloy	-
4	Rod packing	NBR	-
5	Rod	Stainless steel	Hard chrome plated

No	Parts	Material	Remark
6	Piston	Copper alloy	-
7	Piston packing	NBR	-
8	Magnet Holder	Copper alloy	-
9	Magnet	-	-
10	Rod nut	Carbon steel	Zinc plated

Bore size Ø12~Ø16

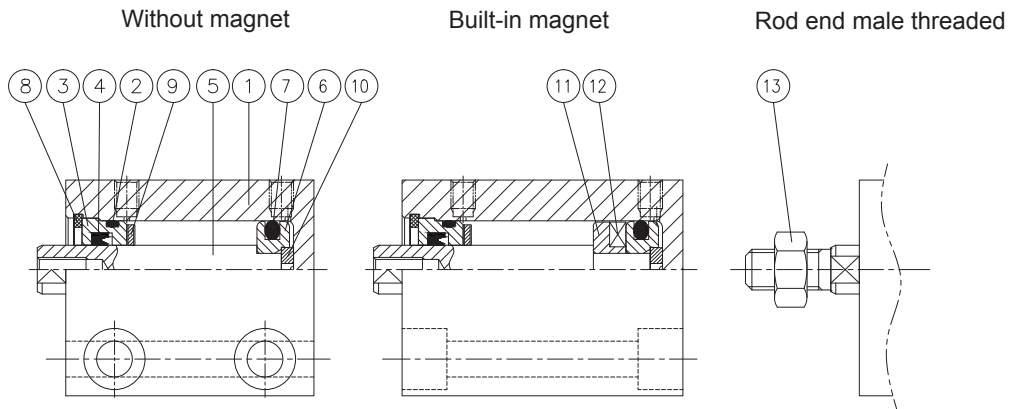

No	Parts	Material	Remark
1	Cylinder tube	Aluminum alloy	Hard anodized
2	Tube O-ring	NBR	-
3	Rod cover	Copper alloy	-
4	Rod packing	NBR	-
5	Rod	Carbon steel	Hard chrome plated
6	Piston	Copper alloy	-
7	Piston packing	NBR	-

No	Parts	Material	Remark
8	Snap Ring	Spring steel	-
9	Dumper A	Urethane	-
10	Dumper B	Urethane	-
11	Magnet Holder	Copper alloy	-
12	Magnet	-	-
13	Rod nut	Carbon steel	Zinc plated

Dimensions-Bore size Ø12 ~ Ø16

Lateral Mounting (B)

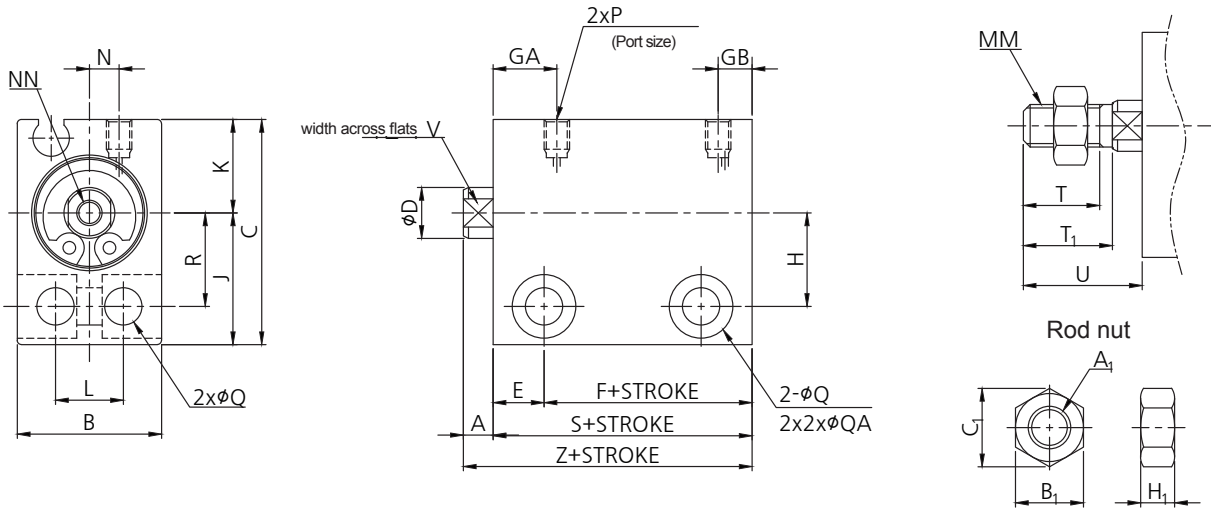

Unit: mm

Bore size	A	B	C	D	E	GB	H	J	K	L	MM	NN	N	P	Q	A1	H1	B1	C1
Ø12	3.5	17	26.5	6	6	4	11	15.5	11	8	M5x0.8	M3x0.5 effective depth 6	3.5	M3x0.5	4.4 through	M5x0.8	4	8	9.2
Ø16	3.5	21	29.5	8	6	4	12.5	17	12.5	11.5	M6x1	M4x0.7 effective depth 8	5.5	M3x0.5	4.4 through	M6x1	5	10	11.5

Bore size	QA	R	T	T1	U	V	W	without magnet				built-in magnet			
								F	GA	S	Z	F	GA	S	Z
Ø12	7.5 C.B.depth 7	11	9	10.5	14	5	26	3.5	7.5	15.5	19	7.5	7.5	19.5	23
Ø16	7.5 C.B.depth 7	12.5	10	12	15.5	6	27.5	4	8.5	16.5	20	8.5	9	21	24.5

Axial Mounting (S)

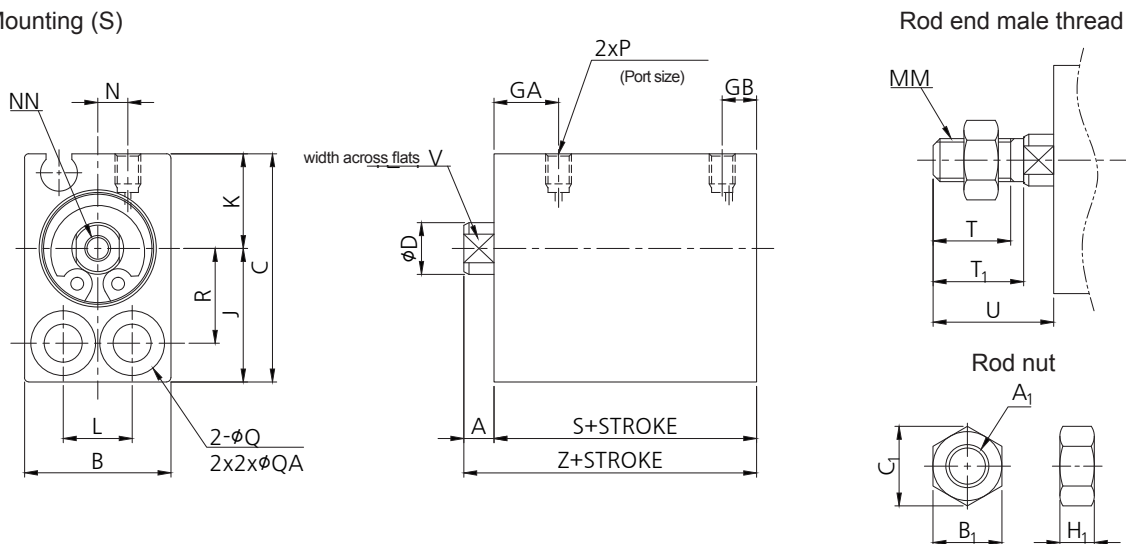

Unit: mm

Bore size	A	B	C	D	GB	J	K	L	MM	NN	N	P	Q	A1	H1	B1	C1
Ø12	3.5	17	26.5	6	4	15.5	11	8	M5x0.8	M3x0.5 effective depth 6	3.5	M3x0.5	4.4 through	M5x0.8	4	8	9.2
Ø16	3.5	21	29.5	8	4	17	12.5	11.5	M6x1	M4x0.7 effective depth 8	5.5	M3x0.5	4.4 through	M6x1	5	10	11.5

Bore size	QA	R	T	T1	U	V	W	without magnet			built-in magnet		
								GA	S	Z	GA	S	Z
Ø12	7.5 C.B.depth 5.5	11	9	10.5	14	5	26	7.5	15.5	19	7.5	19.5	23
Ø16	7.5 C.B.depth 5.5	12.5	10	12	15.5	6	27.5	8.5	16.5	20	9	21	24.5