

CCTS series



Features

- It converts air pressure to equivalent hydraulic pressure. The hydraulic pressure is used to operate an actuator.
- It solves the sticking and slipping problems with low speed operations.
- It can be driven at a constant speed by momentary operation by air pressure compression.

Symbol

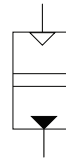

How to Order

CCTS - 63 - 100

①

②

③

① Series

CCTS	Air-hydro converter
------	---------------------

② Bore size

Bore size	Converter nominal size (mm)	Air port size	Oil port size
63	Ø63	Rc(PT)3/8	Rc(PT)3/4
100	Ø100	Rc(PT)1/2	Rc(PT)1"
140	Ø140	Rc(PT)1/2	Rc(PT)1"
160	Ø160	Rc(PT)3/4	Rc(PT)3/4"

③ Stroke

50, 100, 150, 200, 250, 300, 400, 450, 500, 600, 700, 800

※ Contact us for other stroke.

Specifications

Fluid	Turbine Oil (40~100mm ² /S)
Proof pressure	10.3kgf/cm ² (1.05MPa)
Operating pressure	0~6.9kgf/cm ² (0~0.7MPa)
Ambient & fluid temperature	5 ~ 50℃

Converter nominal size (mm)	cross sectional area	Standard effective oil level stroke (cm ³)											Limited flow l/min
		50	100	150	200	250	300	400	500	600	700	800	
Ø63	31.2	125	281	436	592	748	904	1,216	1,527	1,839	-	-	36
Ø100	78.5	314	707	1,100	1,492	1,885	2,278	3,063	3,848	4,634	-	-	88
Ø140	153.9	-	1,385	-	2,925	-	4,464	6,004	7,543	9,082	10,622	12,161	150
Ø160	201.1	-	1,810	-	3,820	-	5,831	7,841	9,852	11,863	13,873	15,884	217

Dimensions

CCTS 63

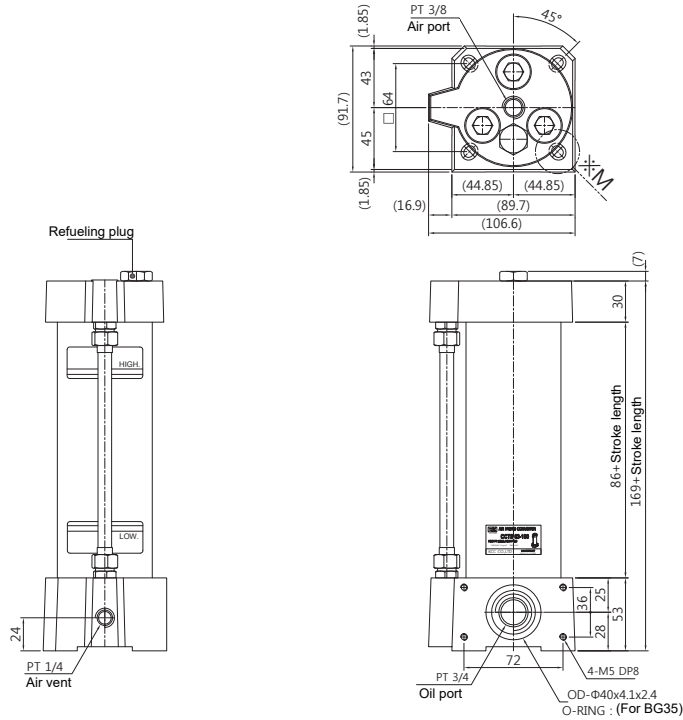

Accessories included with the shipment

1. Hex Socket Wrench Bolt: M6x60L-4EA
2. O-ring: BG35-1EA (For oil port)

※M details (S=2)

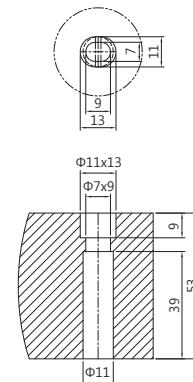

CCTS 100

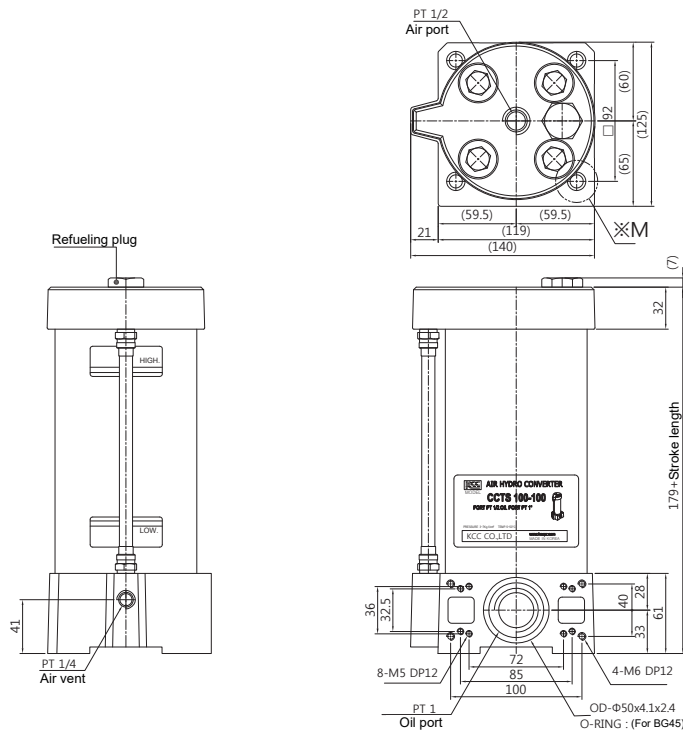

Accessories included with the shipment

1. Hex Socket Wrench Bolt: M8x70L-4EA
2. O-ring: BG45-1EA (For oil port)

※M details (S=2)

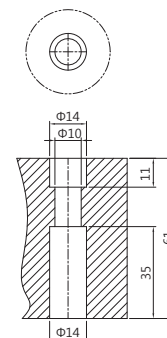

Dimensions

CCTS 140

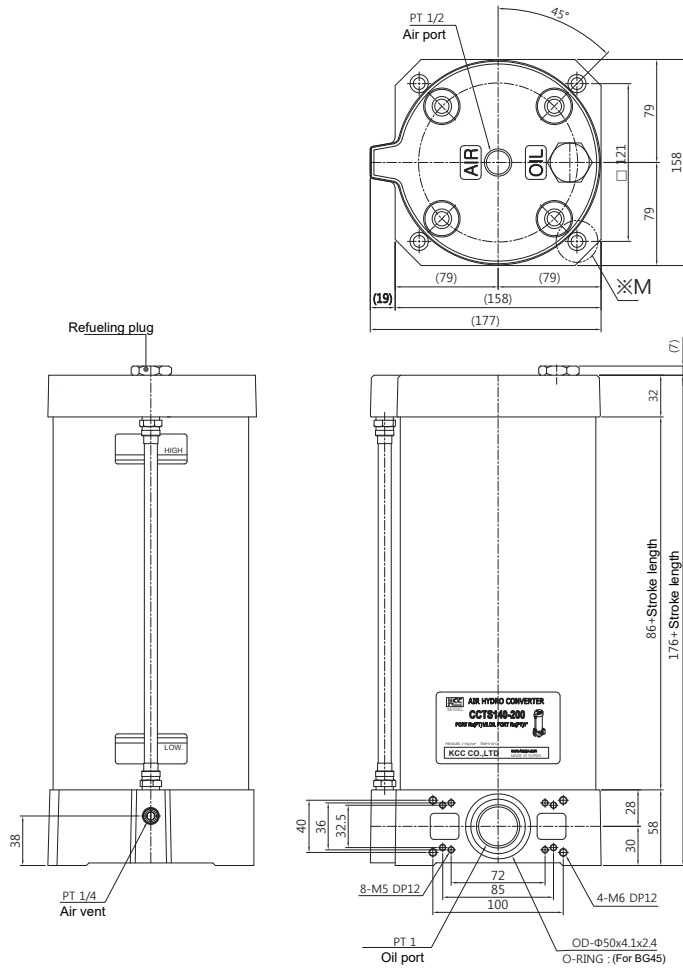

Accessories included with the shipment

1. Hex Socket Wrench Bolt: M8x70L-4EA
2. O-ring: BG45-1EA (For oil port)

※M details (S=2)

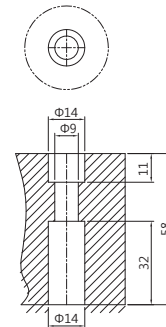

Dimensions

CCTS 160

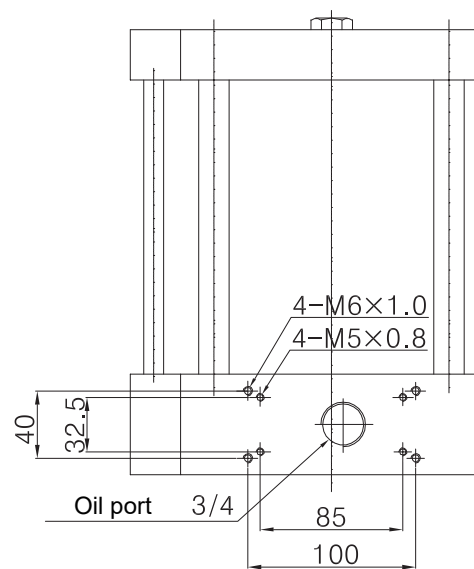
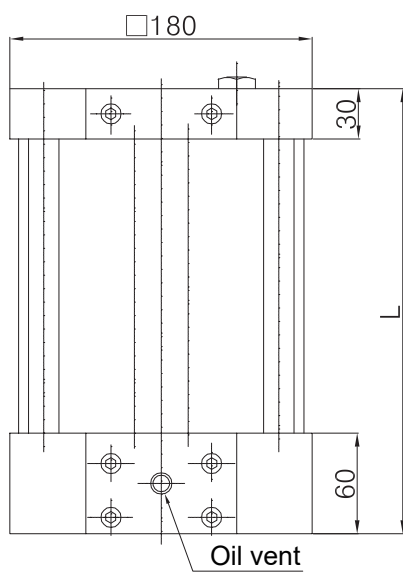
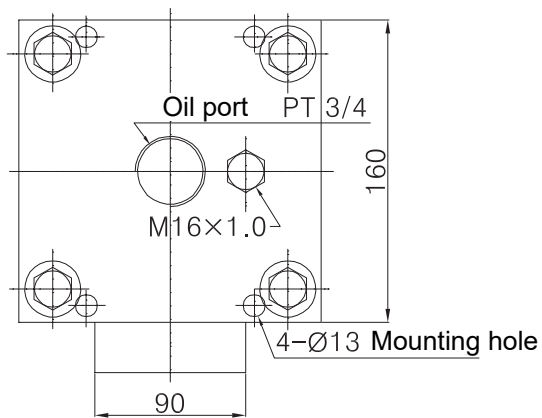

Application Circuit

Key points in applying circuit design

- **Dual circuit as the standard circuit**
A converter is fitted at the rod side and at the head side of cylinder each, to prevent air inflow on occurrence of leak at the cylinder piston packing, and this is applied as the standard circuit.
- **Meter-out circuit control**
The assembly will control the oil that is returned from a cylinder to a converter.
- **Flow Rate Setup**
Select the pipe, nipples and assembly to satisfy the required flow.
- **Cautions in cylinder selection**
The cylinder must be of the low pressure type. (G or L type)
There is a magnet integrated type too. (Switch is sold separately)

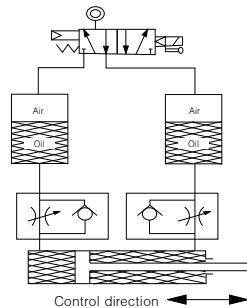

1) Dual Speed Control Circuit

The standard covalence and transformation circuits are used, and both directions of the cylinder are controlled.

- **Application**
 - Feed at low or constant velocity
 - Cutting motion of machine tools
 - Valve open/close
 - Vertically moving load
 - Industrial machinery
 - Woodworking machine and etc

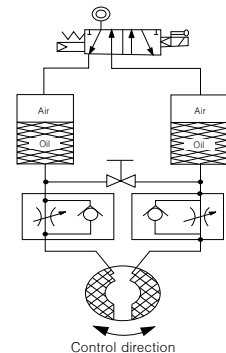

2) Rotary Cylinder Circuit

The Rotary Cylinder Circuit controls speed of the rotary cylinders. The foregoing cylinder is added to a rotary cylinder to enable various circuit configurations. A connection valve is installed to compensate the leakage inside the rotary cylinder.

- **Application**
 - Industrial robots
 - Conveyor
 - Paint equipment
 - Valve open/close
 - Turntable

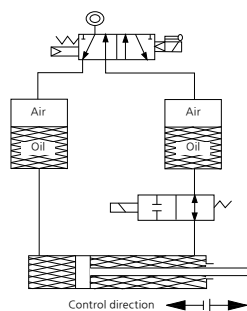

3) Intermediate Stop Circuit

This is used for reliable intermediate stopping.

- **Application**
 - Spot welding machine
 - Machine tool
 - Valve open/close

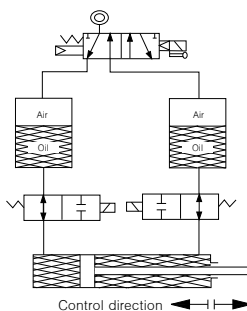

4) Locking Circuit

This is used for intermediate stopping in forward and reverse movements. Even the pneumatic source is blocked, this circuit ensures a reliable locking.

- **Application**
 - Valve open/close
 - Vertical moving load
 - Welding machine

Application Circuit

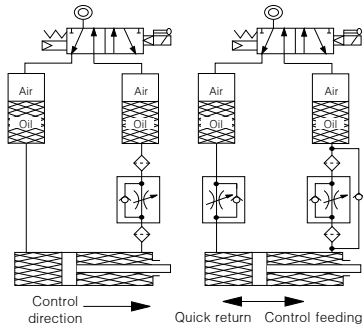

5) Low Speed Stable Circuit

This is an example of 5~10 μ m filters being fitted in front and rear of a throttle valve in order to facilitate stable movement at low speed and to prevent any adverse effect of foreign materials in the hydraulic fluid. The throttle valve should be in V-groove shape. There is a case where hydraulic fluid of high viscosity is stably used at 10mm/min. If the cylinder speed is less than 40mm/min, use this control circuit.

- Application
- Cutting motion of machine tool
- Medical device
- Feed system in industrial machinery
- Camera processing machine
- Semi-conductor manufacturing equipment
- Testing devices

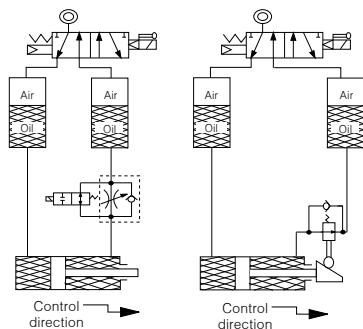

6) 2 Stage-Speed Control Circuit

The circuit for 2 stage-speed transmission for rapid feed and cutting feed, enables a step feed, multiple program-transmissions when fitted with solenoid and throttle valves, and absorbing of impact during switching when fitted with mechanical valves.

- Application
- Cutting feed of machine tool
- Butterfly valve open/close
- cushioning device

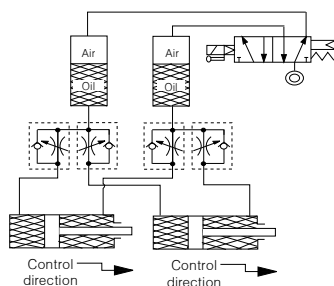

7) Synchronising Circuit

The synchronising circuit is used to synchronise multiple cylinders. If the cylinder rods are connected, synchronising is satisfactory; if they are not connected, synchronising is poor after the air valve is being switched. The cushion packing must be removed with this circuit.

- Application
- Vertical table feed
- Arm synchronising
- Lifter
- Extruder

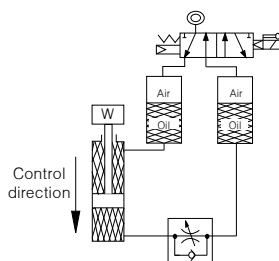

8) Impact Prevention Circuit

This is used for shock absorbers and on the spot where impact is being made by falling weights.

- Application
- Lifter
- Conveyor
- Packing machine
- Dental lab equipment

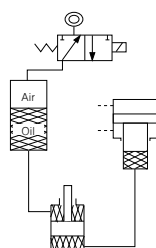

9) Auxiliary Circuit for Booster

This is used for RAM return in air-hydro boosters.

- Application
- Dental lab equipment
- Mold