

ACS4 series



Features

- Aluminum tube
- With built-in magnet (Standard).
- With non-lubricated seal.
- Improved bush decreases deflection and improves lateral load resistance.
- Easy maintenance with screw fastening.
- Rod seal is easy to be replaced
- A floating cushion seal is applied.

Symbol	
Double Acting / Single Rod	Single Acting / Spring Return
Double Acting / Double Rod	Single Acting / Spring Extend

How to Order

ACS4 - N LB 32 - S 100

① Series

ACS4	Double acting single rod small cylinder
ACS4 W	Double acting double rod small cylinder
ACS4A	Double acting single rod small cylinder (With air cushion)
ACS4W	Double acting double rod small cylinder (With air cushion)

② Type

Nil	Non-lubricated (Standard)
L	Low hydraulic pressure (≤9.9kgf/cm ²)

③ Mounting style

B	Standard	CD	Integrated clevis
LB	Foot	TR	Rod side trunnion
FA	Rod side flange	TH	Head side trunnion
FB	Head side flange	BC	Boss-cut (Standard)
CA	Single clevis	BF	Boss-cut flange
CB	Double clevis	BT	Boss-cut trunnion

④ Bore size

20	25	32	40
∅20	∅25	∅32	∅40

⑤ Cylinder stroke

Bore size	Standard stroke	Max. stroke
∅20	10, 15, 20, 25, 30, 35,	1000
∅25	40, 45, 50, 60, 75, 100, 125, 150, 175,	1500
∅32	200, 250, 300, 350, 400, 450, 500, 550, 600	2000
∅40	25, 50, 75, 100, 125, 150, 175, 200, 250, 300, 350, 400, 450, 500, 600	2000

- ※ Other intermediate strokes is available upon request.
- ※ Refer to page [1]-133, for Specification about custom-made rod ends.

⑥ Bellows

Type	Material	Max. ambient temperature
Nil	Without bellows	
J	Nylon Tarpaulin	60°C
K	Neoprene cloth	110°C

⑦ Rod end attachment

Nil	Rod end nut (Standard): 1pc
I	Single knuckle joint
Y	Double knuckle joint

⑧ Auto switch

Reed A/S	Model	Solid State A/S	Model
C72	D-C72K	H7A1	D-H7A1K
C73	D-C73K	H7A2	D-H7A2K
C76	D-C76K	H7B	D-H7BK
C80	D-C80K		

- ※ Refer to Auto Switch Catalogue for more information.
- ※ Only for auto switch attached type.

⑨ Number of auto switches

Nil	2 pcs
1	1 pc
N	N pcs (N: 3, 4, 5...)

- ※ Only for auto switch attached type.

⑩ Special order

Nil	None
TS	Multi-step stroke cylinder(Single rod)
TW	Multi-step stroke cylinder(Double rod)
TD	Tandem cylinder
ASJ	Stroke adjustable type (In forward direction within 25mm)
BSJ	Stroke adjustable type (In forward direction within 50mm)
SV	Heat resistant cylinder
SS	Stainless steel piston rod

⑪ Working format

Nil	Double acting cylinder
S	Single acting spring return
T	Single acting spring extend

Specifications

Type	Non-Lubricated			Low hydraulic pressure
	Double acting, Single rod	Double acting, Double rod	Single acting return(S) / Single acting extend(T)	
Fluid	Air			Hydraulic fluid
Proof pressure	14.7kgf/ cm ² (1.5MPa)			
Max. operating pressure	9.9kgf/ cm ² (1.0MPa)			Low Hydraulic L Type: 9.9kgf/ cm ² (1.0MPa)
Min. operating pressure	0.5kgf/ cm ² (0.05MPa)	0.8kgf/ cm ² (0.08MPa)	Forward: 1.8kgf/ cm ² (0.18MPa) Reverse: 2.3kgf/ cm ² (0.23MPa)	1.8kgf/ cm ² (0.18MPa)
Ambient & fluid temperature	-10°C ~ 70°C(Without auto switch) -10°C ~ 60°C(With auto switch)			
Operating piston speed	Rubber cushion: 50~750mm/s, Air cushion: 50~1000mm/s		Rubber cushion: 50~750mm/s	Rubber cushion: 15~300mm/s
Cushion	Rubber cushion, Air cushion		Rubber cushion	Rubber cushion
Tolerance of thread	KS class 2			
Tolerance of stroke	~250 ST : +1.0 0		251~500 ST : +1.4 0	

Accessory

Mounting style		Standard	Axial foot	Rod side flange	Head side flange	Integrated clevis	Single clevis	²⁾ Double clevis	Rod side trunnion	Head side trunnion	Boss cut	Boss cut flange	Boss cut trunnion
Standard	Mounting screw	●(1pc)	●(2pcs)	●(1pc)	●(1pc)	-	-	-	¹⁾ ●(1pc)	¹⁾ ●(1pc)	●(1pc)	●(1pc)	●(1pc)
	Rod end nut	●	●	●	●	●	●	●	●	●	●	●	●
	Clevis pin	-	-	-	-	-	-	³⁾ ●	-	-	-	-	-
Option	Single knuckle joint	●	●	●	●	●	●	●	●	●	●	●	●
	²⁾ Double knuckle joint	●	●	●	●	●	●	●	●	●	●	●	●
	Bellows	●	●	●	●	●	●	●	●	●	●	●	●

- ※ 1)Trunnion nut is included in the rod side trunnion and head side trunnion.
- ※ 2)Pin and snap ring are included in double clevis and double knuckle joint.
- ※ 3)Snap ring is included in clevis pin.
- ※ Double rod type cylinder includes 2pcs rod end nuts.

Mounting Style

Mounting style	Minimum order quantity	Bore size(mm)			Remarks
		Ø20	Ø25	Ø32	
Axial foot	1set (2pcs)	LB 20	LB 25/32		LB 40 (Round type) Foot 2pcs, Nut 1pc
Flange	1pc	FA/FB 20	FA/FB 25/32		FA/FB 40 (Round type) Flange 1pc, Nut 1pc
Single clevis	1pc	CA 20	CA 25/32		CA 40 (Round type) Single clevis 1pc
Double clevis	1pc	CB 20	CB 25/32		CB 40 (Round type) Double clevis 1pc, Clevis pin 1pc, Snap ring 2pcs
Trunnion	1pc	TC 20	TC 25/32		TC 40 (Round type) Trunnion 1pc, Trunnion nut 1pc

Rod End Attachment

Accessory	Bore size(mm)		
	Ø20	Ø25, Ø32	Ø40
Single Knuckle Joint	I20	I25/32	I40
Double Knuckle Joint	Y20	Y25/32	Y40

- ※ Rod end attachment of ACS2 40 and that of ACM 40 are the same.



Mass

Unit: kg

Bore size (mm)		Double acting single rod cylinder				Double acting double rod cylinder			
		Ø20	Ø25	Ø32	Ø40	Ø20	Ø25	Ø32	Ø40
Basis mass	Standard	0.154	0.238	0.288	0.626	0.176	0.283	0.329	0.727
	Foot	0.228	0.316	0.366	0.778	0.250	0.361	0.407	0.879
	Flange	0.198	0.290	0.340	0.734	0.220	0.335	0.381	0.835
	Integrated clevis	0.134	0.208	0.248	0.566	-	-	-	-
	Single clevis	0.204	0.290	0.340	0.754	-	-	-	-
	Double clevis (With pin)	0.214	0.298	0.348	0.788	-	-	-	-
	Trunnion	0.194	0.308	0.348	0.726	0.216	0.353	0.389	0.827
	Boss-cut Standard	0.144	0.218	0.268	0.596	-	-	-	-
	Boss-cut Flange	0.184	0.268	0.318	0.706	-	-	-	-
Boss-cut Trunnion	0.184	0.288	0.328	0.696	-	-	-	-	
Additional mass per each 50mm of stroke		0.064	0.080	0.084	0.140	0.096	0.120	0.137	0.205
Accessory	Single knuckle joint	0.056	0.056	0.056	0.166	-	-	-	-
	Double knuckle joint (With pin)	0.074	0.072	0.072	0.220	-	-	-	-
	Rod nut	0.002	0.008	0.008	0.016	-	-	-	-

Calculation:

1. Double acting single rod cylinder

Ex) ACS4-N-LB32-S100

Basis mass: 0.366(FootØ32) / Additional mass: 0.084/50 / Stroke: 100mm
 $0.366 + 0.084/50 \times 100 = 0.534\text{kg}$

2. Double acting double rod cylinder

Ex) ACS4W-N-LB32-S100

Basis mass: 0.407(FootØ32) / Additional mass: 0.137/50 / Stroke: 100mm
 $0.398 + 0.137/50 \times 100 = 0.681\text{kg}$

Structure

Standard (Non lubricated) ACS4A-N B

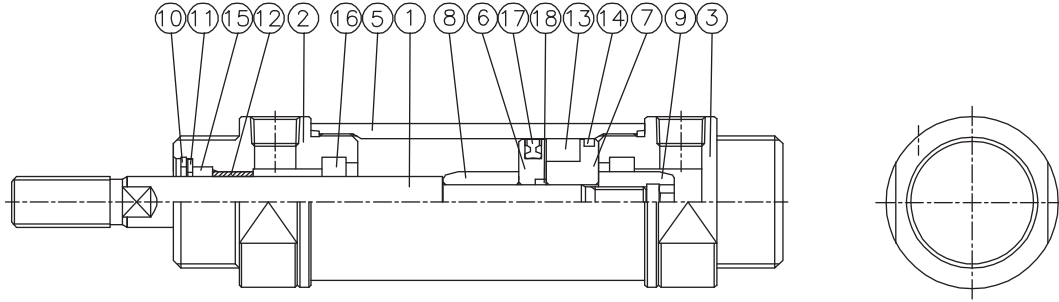

Boss-cut ACS4A-N BC

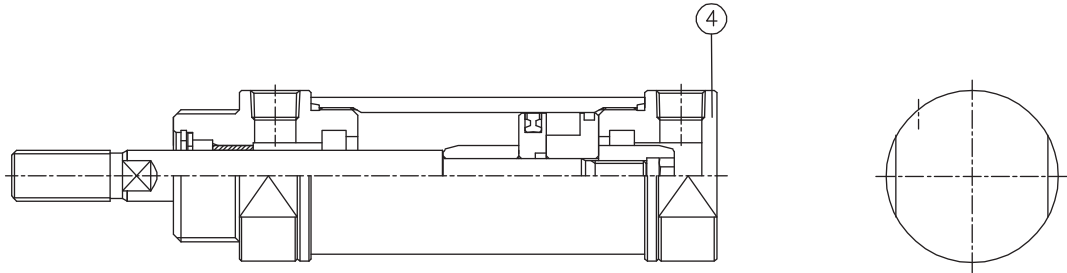

Part no.	Parts	Material	Remark
1	Rod	Carbon Steel	Hard Chromium Plating
2	Rod Cover	AL Alloy	White Anodizing
3	Head Cover	AL Alloy	White Anodizing
4	Head Cover	AL Alloy	Boss Cut Type
5	Cylinder Tube	AL Alloy	-
6	Piston	AL Alloy	-
7	Magnet Holder	AL Alloy	-
8	Cushion Ring	AL Alloy	-
9	Cushion Ring Nut	AL Alloy	-
10	Stop Ring	Carbon Tool Steel	-
11	Packing Wash	Rolled Steel	-
12	Bush	Sintered Metal	-
13	Magnet	-	-
14	Wearing	Resin	-

Part no.	Parts	Material	Bore size			
			Ø20	Ø25	Ø32	Ø40
15	Rod Packing	NBR	DRP8	DRP10	DRP12	DRP14
16	Cushion Packing	NBR	-	-	-	-
17	Piston Packing	NBR	OPA20	OPA25	OPA32	OPA40
18	Rod O-Ring	NBR	S6	S6	S8	S10

Dimensions-Standard (B)

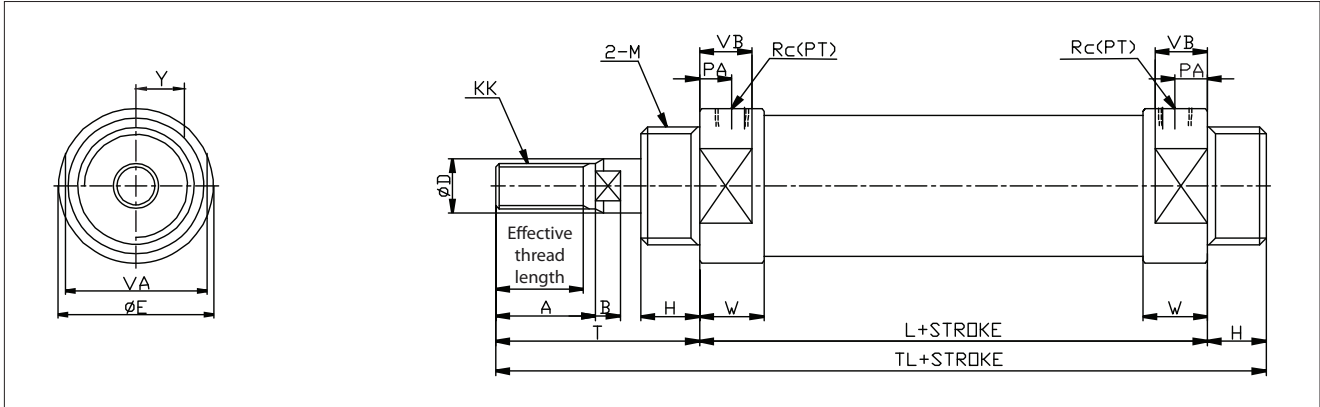

Unit : mm

Bore size	Effective thread length	A	B	ØD	ØE	H	KK	L	M	PA	Rc(PT)	T	TL
Ø20	15.5	18	5.0	8	28	13	M8X1.25	62	M20X1.5	8	1/8	41	116
Ø25	19.5	22	5.5	10	34	13	M10X1.25	62	M26X1.5	8	1/8	45	120
Ø32	19.5	22	5.5	12	38	13	M10X1.25	64	M26X1.5	8	1/8	45	122
Ø40	21.0	24	7.5	14	50	16	M14X1.50	88	M32X2.0	11	1/4	50	154

Bore size	VA	VB	W
Ø20	24	12	15
Ø25	30	12	15
Ø32	32	12	15
Ø40	46	18	21

Dimensions-Foot (LB)

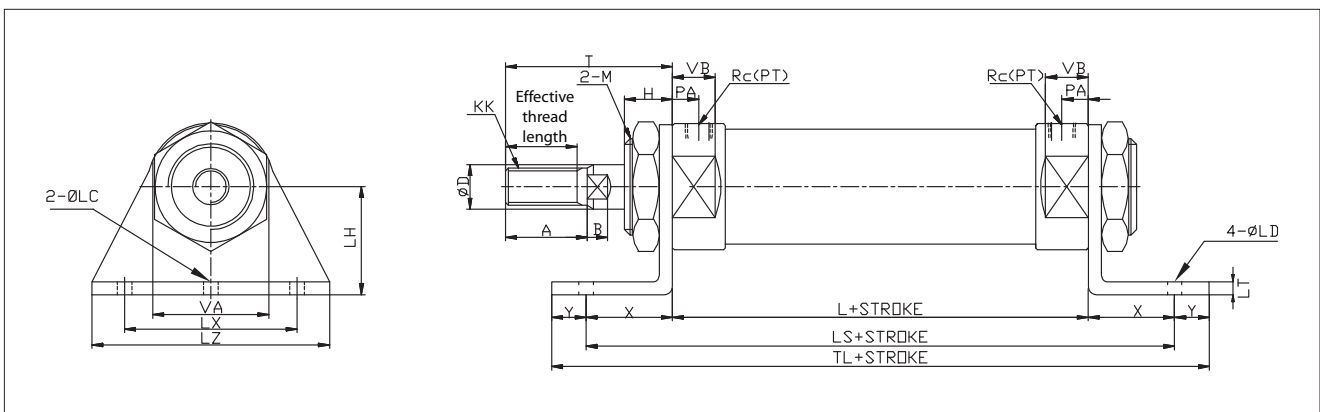

Unit:mm

Bore size	Effective thread length	A	B	ØD	H	KK	L	ØLC	ØLD	LH	LS	LT	LX	LZ
Ø20	15.5	18	5.0	8	13	M8X1.25	62	4	6.8	25	102	3	40	55
Ø25	19.5	22	5.5	10	13	M10X1.25	62	4	6.8	28	102	3	40	55
Ø32	19.5	22	5.5	12	13	M10X1.25	64	4	6.8	28	104	3	40	55
Ø40	21.0	24	7.5	14	16	M14X1.50	88	4	7.0	30	134	3	55	75

Bore size	M	PA	Rc(PT)	T	TL	VA	VB	W	X	Y
Ø20	M20X1.5	8	1/8	41	118	24	12	15	20	8
Ø25	M26X1.5	8	1/8	45	118	30	12	15	20	8
Ø32	M26X1.5	8	1/8	45	120	32	12	15	20	8
Ø40	M32X2.0	11	1/4	50	158	46	18	21	23	12

Dimensions-Rod side flange (FA)

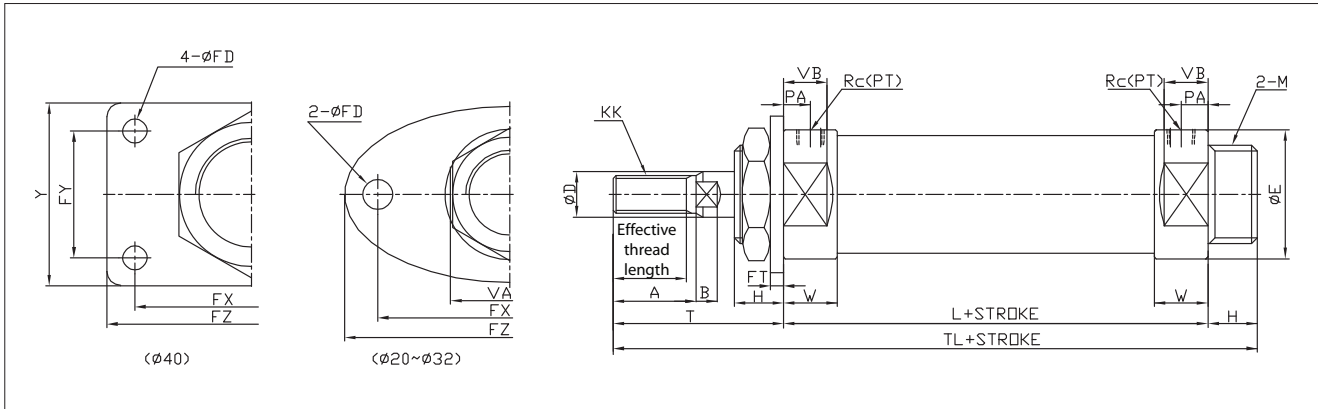

Unit:mm

Bore size	Effective thread length	A	B	ØD	ØE	ØFD	FT	FX	FY	FZ	H	KK	L	M
Ø20	15.5	18	5.0	8	28	7	3.2	60	-	75	13	M8X1.25	62	M20X1.5
Ø25	19.5	22	5.5	10	34	7	4.5	60	-	75	13	M10X1.25	62	M26X1.5
Ø32	19.5	22	5.5	12	38	7	4.5	60	-	75	13	M10X1.25	64	M26X1.5
Ø40	21.0	24	7.5	14	50	7	4.5	66	36	82	16	M14X1.50	88	M32X2.0

Bore size	PA	Rc(PT)	T	TL	VA	VB	W	Y
Ø20	8	1/8	41	116	24	12	15	40
Ø25	8	1/8	45	120	30	12	15	42
Ø32	8	1/8	45	122	32	12	15	42
Ø40	11	1/4	50	154	46	18	21	52

Dimensions-Head side flange (FB)

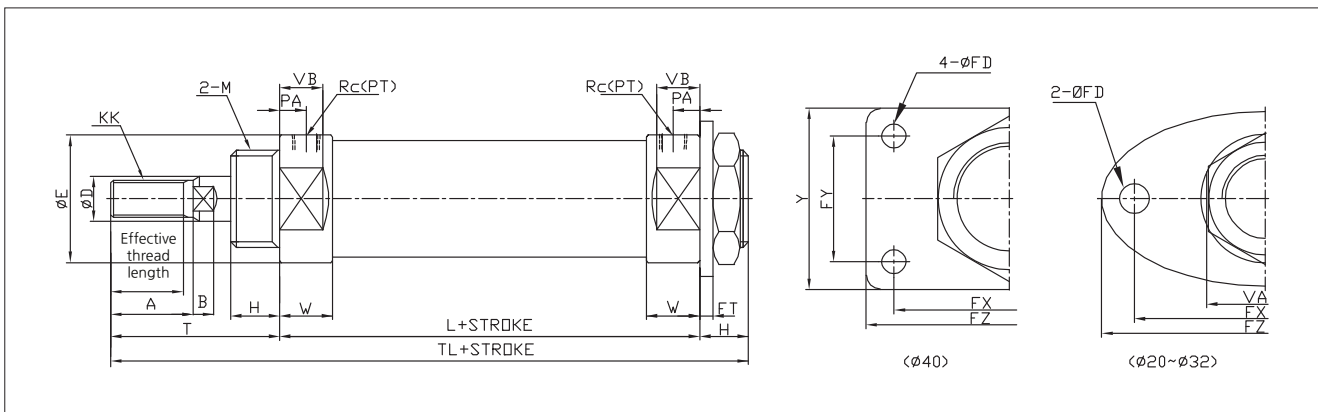

Unit:mm

Bore size	Effective thread length	A	B	ØD	ØE	ØFD	FT	FX	FY	FZ	H	KK	L	M
Ø20	15.5	18	5.0	8	28	7	3.2	60	-	75	13	M8X1.25	62	M20X1.5
Ø25	19.5	22	5.5	10	34	7	4.5	60	-	75	13	M10X1.25	62	M26X1.5
Ø32	19.5	22	5.5	12	38	7	4.5	60	-	75	13	M10X1.25	64	M26X1.5
Ø40	21.0	24	7.5	14	50	7	4.5	66	36	82	16	M14X1.50	88	M32X2.0

Bore size	PA	Rc(PT)	T	TL	VA	VB	W	Y
Ø20	8	1/8	41	116	24	12	15	40
Ø25	8	1/8	45	120	30	12	15	42
Ø32	8	1/8	45	122	32	12	15	42
Ø40	11	1/4	50	154	46	18	21	52

Dimensions-Single clevis (CA)

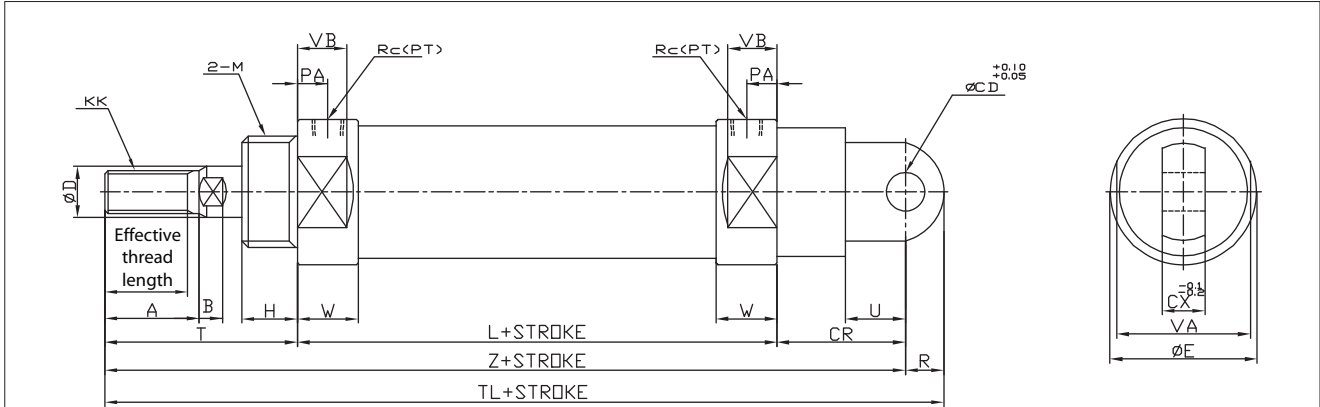

Unit:mm

Bore size	Effective thread length	A	B	ØCD	CR	CX	ØD	ØE	H	KK	L	M	PA
Ø20	15.5	18	5.0	9	30	10	8	28	13	M8X1.25	62	M20X1.5	8
Ø25	19.5	22	5.5	9	30	10	10	34	13	M10X1.25	62	M26X1.5	8
Ø32	19.5	22	5.5	9	30	10	12	38	13	M10X1.25	64	M26X1.5	8
Ø40	21.0	24	7.5	10	39	15	14	50	16	M14X1.50	88	M32X2.0	11

Bore size	R	Rc(PT)	T	TL	U	VA	VB	W	Z
Ø20	9	1/8	41	142	14	24	12	15	133
Ø25	9	1/8	45	146	14	30	12	15	137
Ø32	9	1/8	45	148	14	32	12	15	139
Ø40	11	1/4	50	188	18	46	18	21	177

Dimensions-Double clevis (CB)

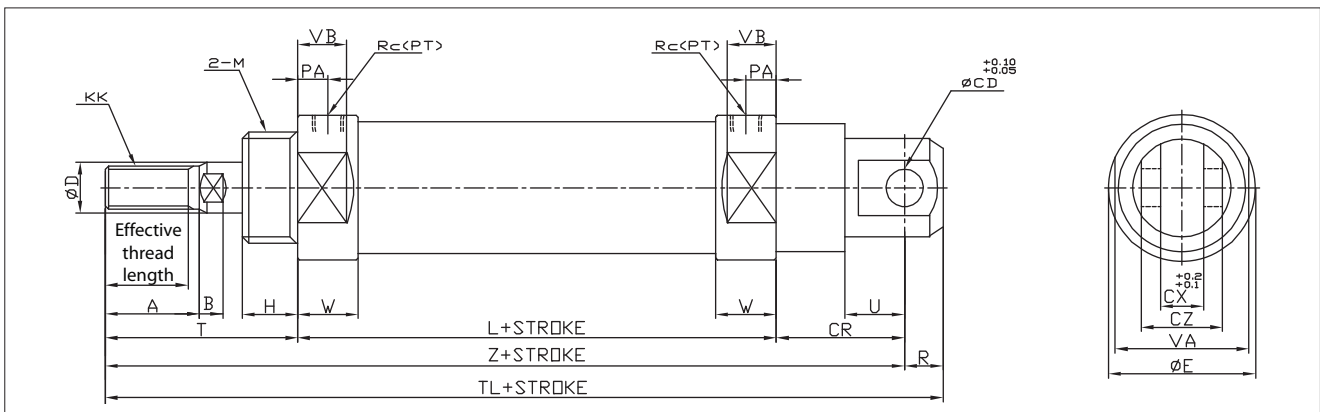

Unit:mm

Bore size	Effective thread length	A	B	ØCD	CR	CX	CZ	ØD	ØE	H	KK	L	M
Ø20	15.5	18	5.0	9	30	10	19	8	28	13	M8X1.25	62	M20X1.5
Ø25	19.5	22	5.5	9	30	10	19	10	34	13	M10X1.25	62	M26X1.5
Ø32	19.5	22	5.5	9	30	10	19	12	38	13	M10X1.25	64	M26X1.5
Ø40	21.0	24	7.5	10	39	15	30	14	50	16	M14X1.50	88	M32X2.0

Bore size	PA	R	Rc(PT)	T	TL	U	VA	VB	W	Z
Ø20	8	9	1/8	41	142	14	24	12	15	133
Ø25	8	9	1/8	45	146	14	30	12	15	137
Ø32	8	9	1/8	45	148	14	32	12	15	139
Ø40	11	11	1/4	50	188	18	46	18	21	177

Dimensions-Integrated clevis (CD)

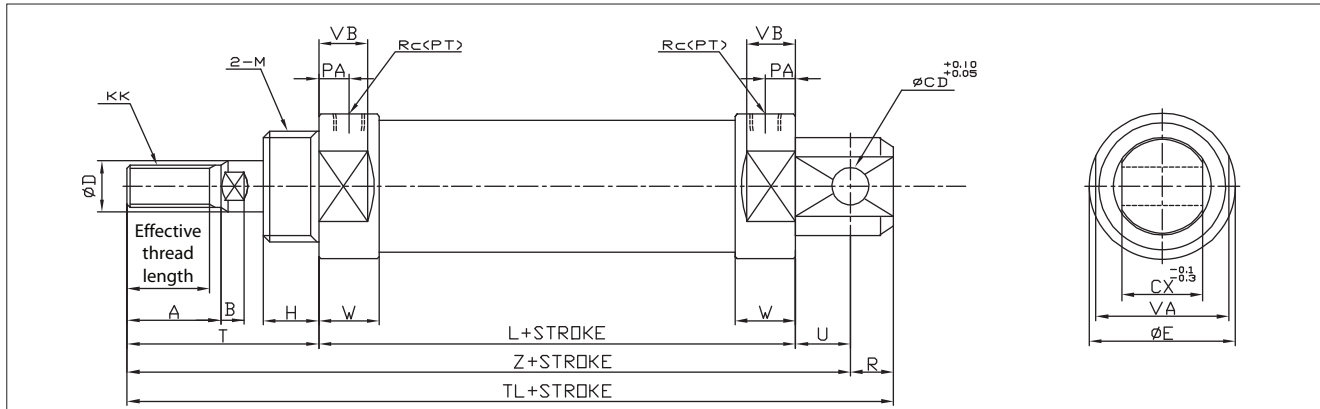

Unit:mm

Bore size	Effective thread length	A	B	ØCD	CX	ØD	ØE	H	KK	L	M	PA	R
Ø20	15.5	18	5.0	8	12	8	28	13	M8X1.25	62	M20X1.5	8	9
Ø25	19.5	22	5.5	8	12	10	34	13	M10X1.25	62	M26X1.5	8	10
Ø32	19.5	22	5.5	10	20	12	38	13	M10X1.25	64	M26X1.5	8	12
Ø40	21.0	24	7.5	10	20	14	50	16	M14X1.50	88	M32X2.0	11	12

Bore size	Rc(PT)	T	TL	U	VA	VB	W	Z
Ø20	1/8	41	124	12	24	12	15	115
Ø25	1/8	45	129	12	30	12	15	119
Ø32	1/8	45	136	15	32	12	15	124
Ø40	1/4	50	165	15	46	18	21	153

Dimensions-Rod side trunnion (TR)

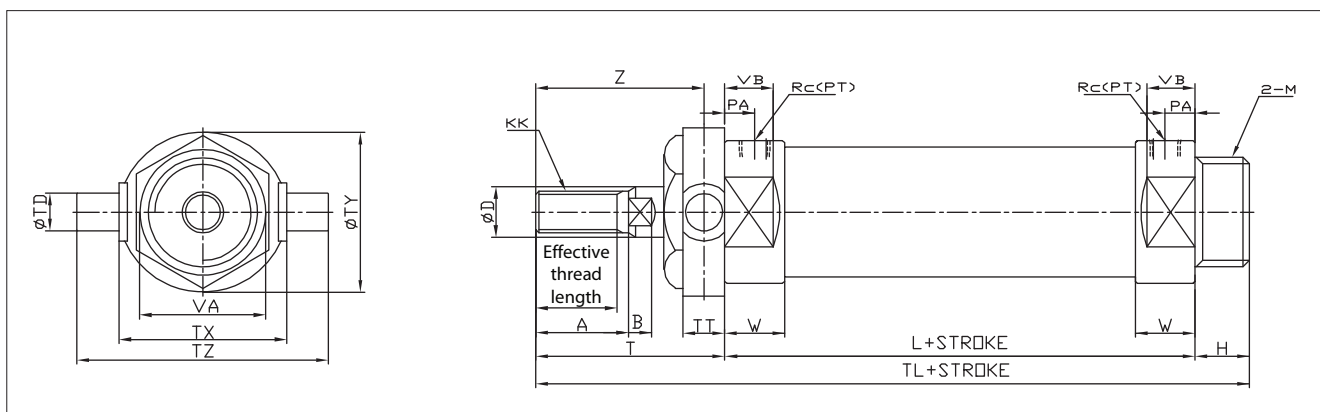

Unit:mm

Bore size	Effective thread length	A	B	ØD	ØE	H	KK	L	M	PA	Rc(PT)	T	ØTD
Ø20	15.5	18	5.0	8	28	13	M8X1.25	62	M20X1.5	8	1/8	41	8
Ø25	19.5	22	5.5	10	34	13	M10X1.25	62	M26X1.5	8	1/8	45	9
Ø32	19.5	22	5.5	12	38	13	M10X1.25	64	M26X1.5	8	1/8	45	9
Ø40	21.0	24	7.5	14	50	16	M14X1.50	88	M32X2.0	11	1/4	50	10

Bore size	TL	TT	TX	ØTY	TZ	VA	VB	W	Z
Ø20	116	10	32	32	52	24	12	15	36
Ø25	120	10	40	40	60	30	12	15	40
Ø32	122	10	40	40	60	32	12	15	40
Ø40	154	11	53	53	77	46	18	21	44.5

Dimensions-Head side trunnion (TH)

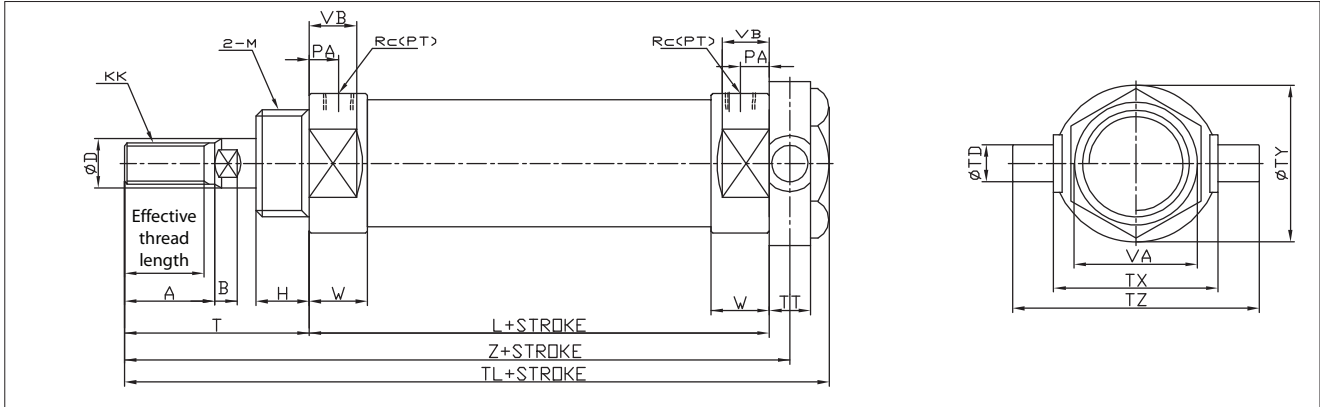

Unit:mm

Bore size	Effective thread length	A	B	ØD	ØE	H	KK	L	M	PA	Rc(PT)	T	ØTD
Ø20	15.5	18	5.0	8	28	13	M8X1.25	62	M20X1.5	8	1/8	41	8
Ø25	19.5	22	5.5	10	34	13	M10X1.25	62	M26X1.5	8	1/8	45	9
Ø32	19.5	22	5.5	12	38	13	M10X1.25	64	M26X1.5	8	1/8	45	9
Ø40	21.0	24	7.5	14	50	16	M14X1.50	88	M32X2.0	11	1/4	50	10

Bore size	TL	TT	TX	ØTY	TZ	VA	VB	W	Z
Ø20	116.5	10	32	32	52	24	12	15	108
Ø25	121.5	10	40	40	60	30	12	15	112
Ø32	123.5	10	40	40	60	32	12	15	114
Ø40	155	11	53	53	77	46	18	21	143.5

Dimensions-Boss-cut (BC)

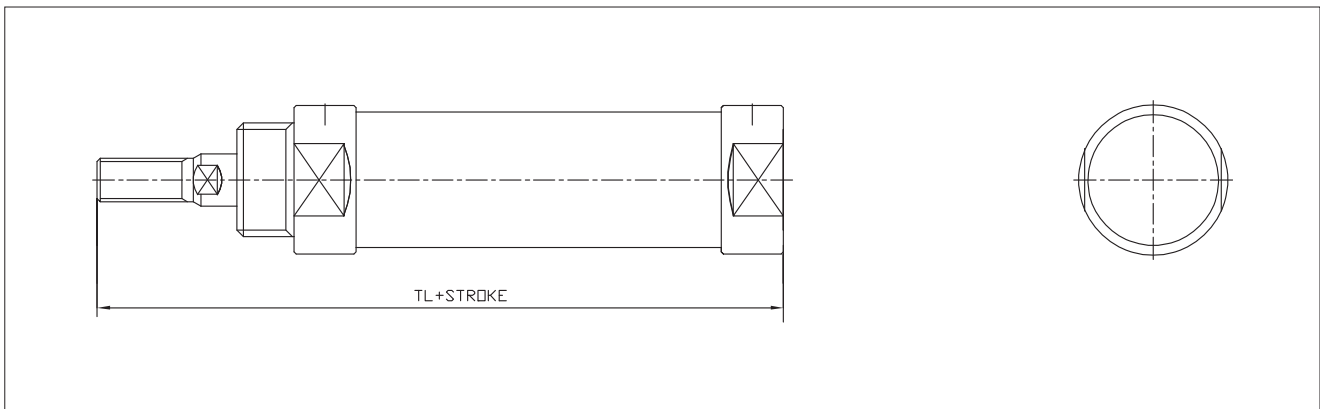

The reduction of the attachment space is achieved by removing the screw portion of the headcover and reducing the overall length.

Unit:mm

Unit:mm

Compact (Boss-cut)	
Bore size	TL
Ø20	103
Ø25	107
Ø32	109
Ø40	138

Overall length dimension comparison(with general form)			
Ø20	Ø25	Ø32	Ø40
-13	-13	-13	-16

※ Attachment type: Standard (BC), Rod side flange (BF), Rod side trunnion (BT)

※ Other dimensions are not the same as ACS4 Standard.

Dimensions-Accessory

Single Knuckle Joint

Material: Free-cutting steel

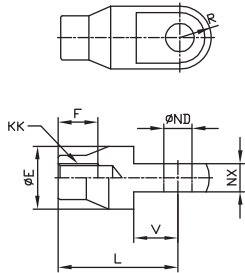

Unit:mm

Part No.	Bore size	øE	F	L	KK	øND ^{H10}	NX	R	V
I20	Ø20	20	16	36	M8X1.25	9 ^{+0.06} ₀	9 ^{-0.1} _{-0.2}	10	14
I25/32	Ø25, 32	20	18	38	M10X1.25	9 ^{+0.06} ₀	9 ^{-0.1} _{-0.2}	10	14
I40	Ø40	24	22	55	M14X1.50	12 ^{+0.07} ₀	16 ^{-0.1} _{-0.3}	15.5	20

Double Knuckle Joint

Y20, Y25/32 Material: Free-cutting steel Y40 Material: Cast iron

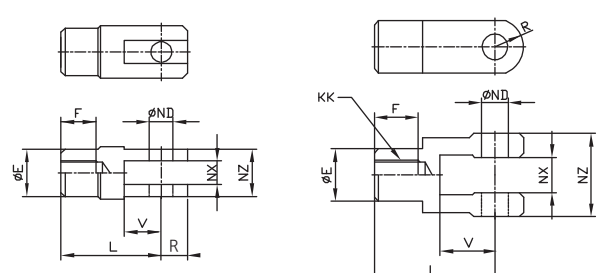

Unit:mm

Part No.	Bore size	øE	F	L	KK	øND ^{H10}	NX	NZ	R	V
Y20	Ø20	18	16	36	M8X1.25	9 ^{+0.06} ₀	9 ^{+0.2} _{+0.1}	18	12	14
Y25/32	Ø25, 32	18	18	38	M10X1.25	9 ^{+0.06} ₀	9 ^{+0.2} _{+0.1}	18	10	14
Y40	Ø40	24	30	55	M14X1.50	12 ^{+0.07} ₀	16 ^{+0.3} _{+0.1}	38	13	25

Rod End Nut

Material: Carbon steel

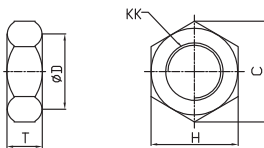

Unit:mm

Part No.	Bore size	C	øD	H	KK	T
RN-02	Ø20	15.0	12.5	13	M8X1.25	5
RN-03	Ø25, 32	19.6	16.5	17	M10X1.25	6
RN-04	Ø40	25.4	21.0	22	M14X1.50	8

Attachment Nut

Material: Carbon steel

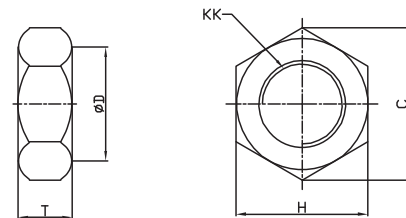

Unit:mm

Part No.	Bore size	C	øD	H	KK	T
SN-02	Ø20	30	25.5	26	M20X1.5	8
SN-03	Ø25, 32	37	31.5	32	M26X1.5	8
SN-04	Ø40	47.3	40.5	41	M32X2.0	10

Clevis Pin

Material: Carbon steel

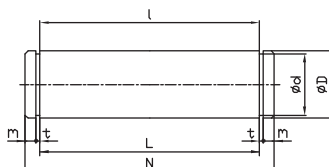

Unit:mm

Part No.	Bore size	øD ^{H9}	ød	L	N	m	t	Remark
CPS-02	Ø20	9 ^{-0.040} _{-0.076}	8.6 ⁰ _{-0.06}	19.2	25	1.75	1.15 ^{+0.14} ₀	Y+CB
CPS-03	Ø25,32	9 ^{-0.040} _{-0.076}	8.6 ⁰ _{-0.06}	19.2	25	1.75	1.15 ^{+0.14} ₀	Y+CB
CPS-04	Ø40	10 ^{-0.040} _{-0.076}	9.6 ⁰ _{-0.09}	30.2	36.2	1.85	1.15 ^{+0.14} ₀	CB
CPM-04	Ø40	12 ^{-0.050} _{-0.093}	11.5 ⁰ _{-0.11}	38.2	44.2	1.85	1.15 ^{+0.14} ₀	Y (Same as ACM400)

Dimensions-Bellows (J, K)

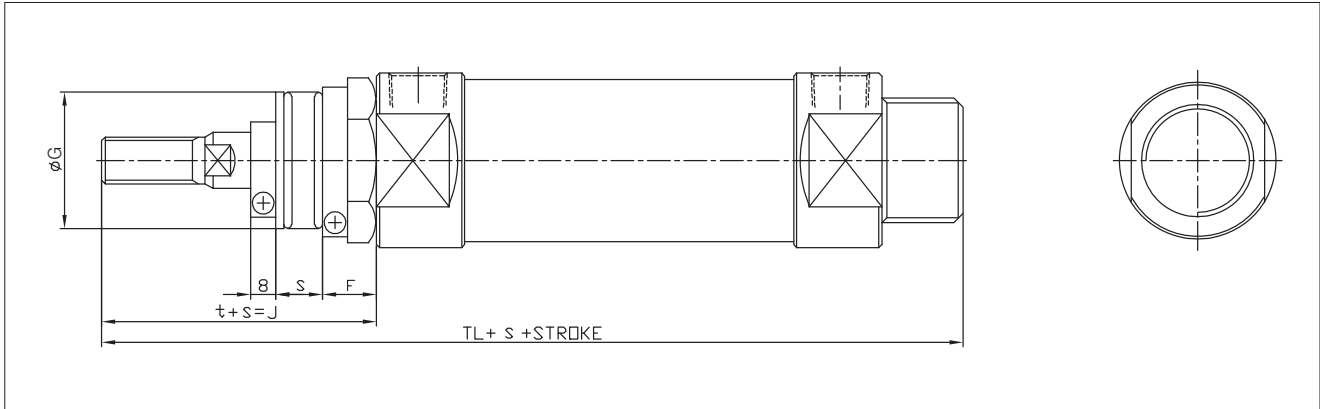

Unit:mm

Bore size	F	ØG	s	t	TL
Ø20	16	39	0.3Stroke+3	56	131
Ø25	16	39	0.3Stroke+3	60	135
Ø32	16	39	0.3Stroke+3	60	137
Ø40	18	40	0.25Stroke+3	67	171

	J	K
Material	Nylon Tarpaulin	Neoprene Cloth
Heat resistant	60°C	110°C

※ Dimensions not indicated are the same as ACS4 Standard.
※ SUS band is attached to bellows.

Dimensions-Double acting double rod (W)

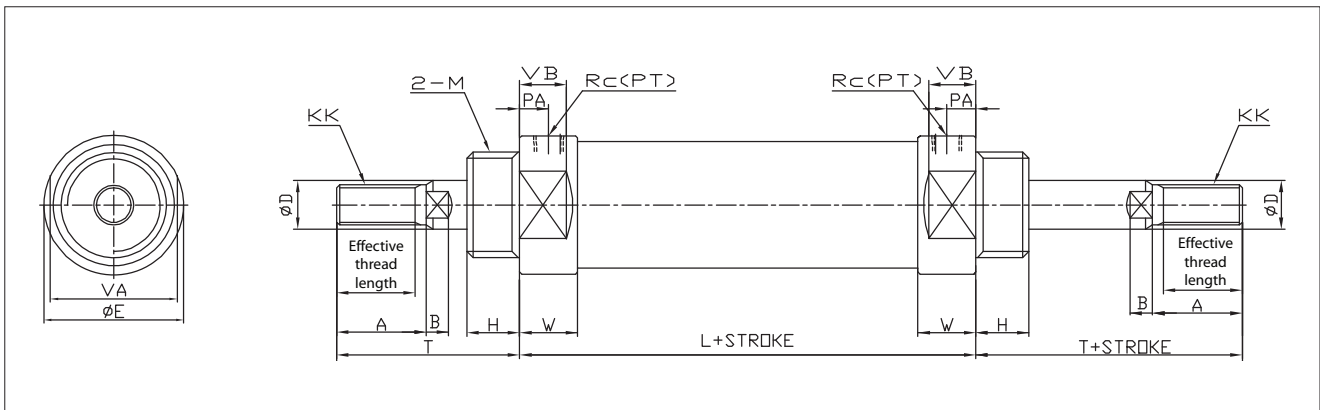

Unit:mm

Bore size	Effective thread length	A	B	ØD	ØE	H	KK	L	M	PA	Rc(PT)	T	TL
Ø20	15.5	18	5.0	8	28	13	M8X1.25	62	M20X1.5	8	1/8	41	144
Ø25	19.5	22	5.5	10	34	13	M10X1.25	62	M26X1.5	8	1/8	45	152
Ø32	19.5	22	5.5	12	38	13	M10X1.25	64	M26X1.5	8	1/8	45	154
Ø40	21.0	24	7.5	14	50	16	M14X1.50	88	M32X2.0	11	1/4	50	188

Bore size	VA	VB	W
Ø20	24	12	15
Ø25	30	12	15
Ø32	32	12	15
Ø40	46	18	21

Single Rod Multi-Step Stroke Cylinder (TS)

By integrating two cylinders in series enable back and forth stroke and two-steps control for a doubled output.

Ordering notation: A Stroke + Total Stroke

Ex) 150 + 200 (A Side = 150, B Side = 50)

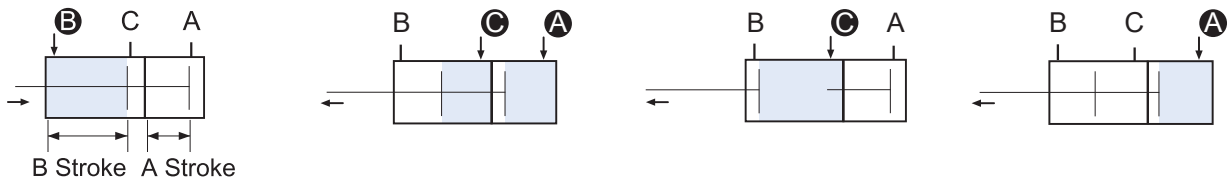

When B port is supplied with air pressure, A and B strokes reverse.

When both A and C ports are supplied with air pressure, forward output is doubled.

When C port is supplied with air pressure, rod and B Stroke move forward.

When A port is supplied with air pressure, rod and A Stroke move forward.

Dimensions-Single Rod Multi-Step Stroke Cylinder (TS)

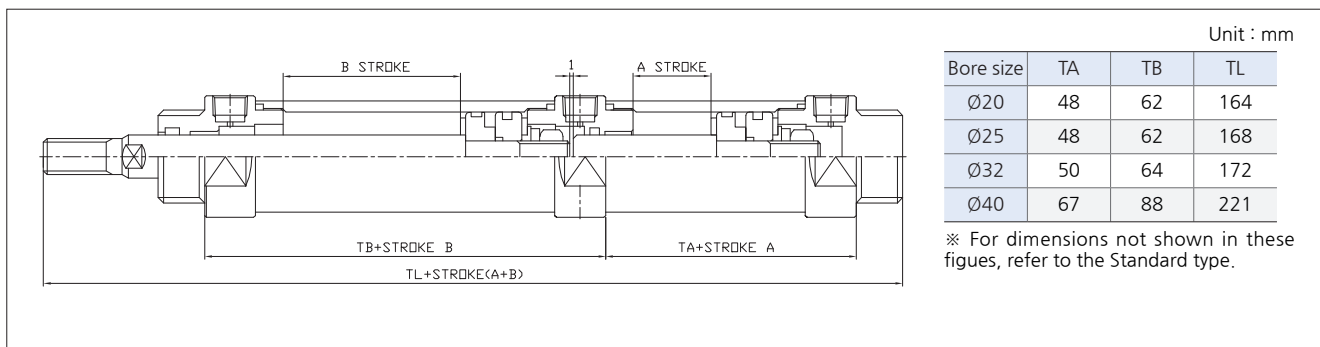

Double Rod Multi-Step Stroke Cylinder (TW)

Head side assembly. By integrating two cylinders enable back and forth stroke and three steps control.

Ordering notation: A Stroke + B Stroke

Example) 150 + 200 (A Side = 150, B Side = 200)

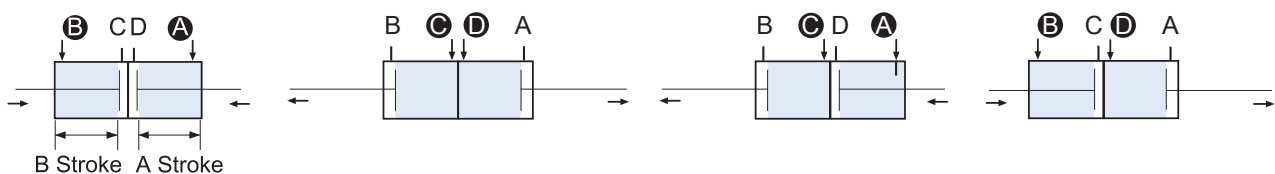

When A and B ports are supplied with air pressure, A and B strokes reverse.

When C and D ports are supplied with air pressure, A and B strokes move forward.

When A and C ports are supplied with air pressure, B stroke move forward.

When B and D ports are supplied with air pressure, A stroke move forward.

Dimensions-Double Rod Multi-Step Stroke Cylinder (TW)

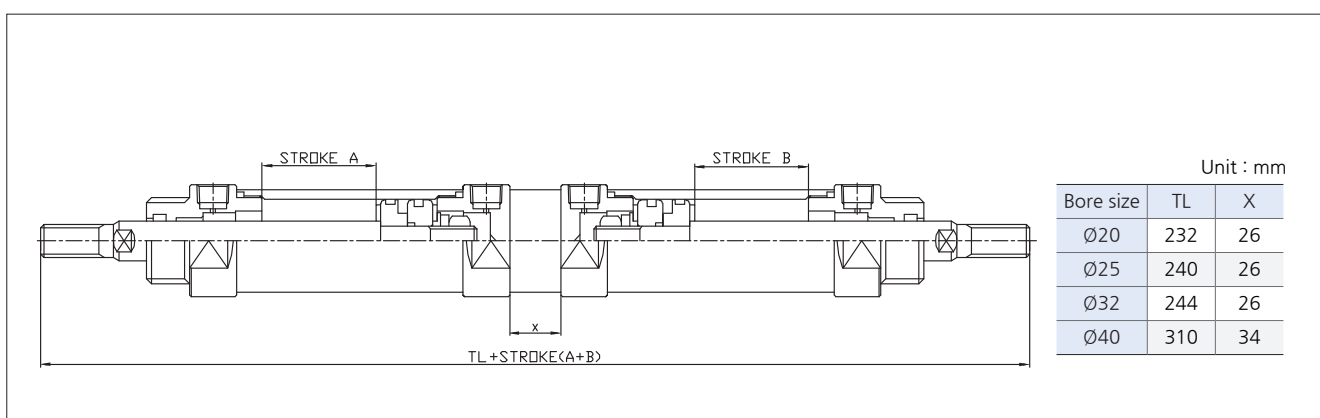

Tandem Cylinder (TD)

Two cylinders connected in series for a doubled output.

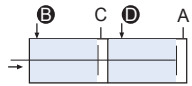

When A and B ports are supplied with air pressure, reverse operating output is doubled.

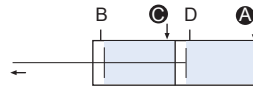

When A and C ports are supplied with air pressure, forward operating output is doubled.

Dimensions-Tandem Cylinder (TD)

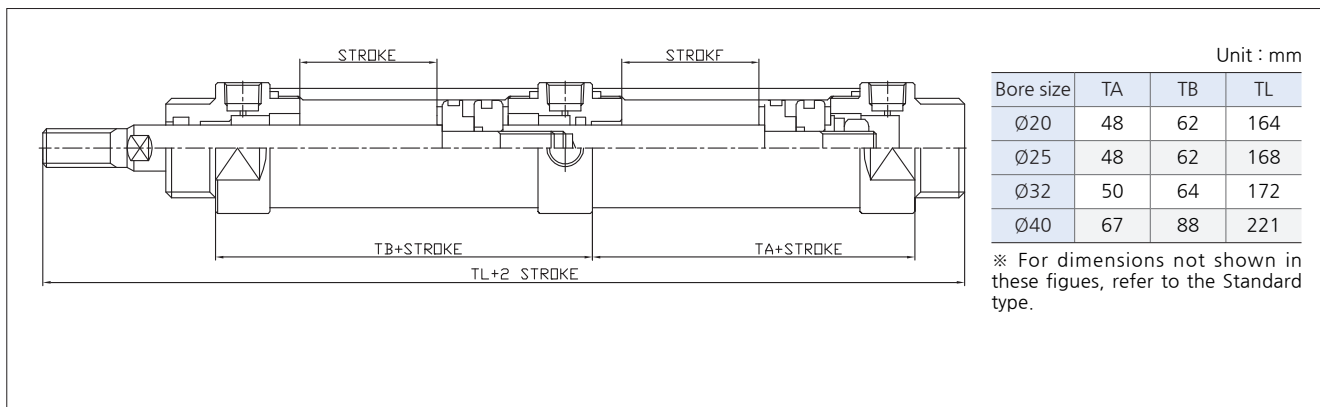

Stroke Adjustable Cylinder (ASJ, BSJ)

To adjust the entire forward stroke from 0mm to 50mm an adjustment mechanism is attached to the head side.

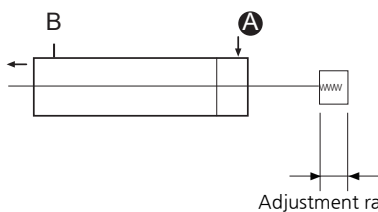

ASJ : 25mm adjustment
BSJ : 50mm adjustment
XSJ : Xmm adjustment (X is defined by user)

Dimensions-Stroke Adjustable Type (ASJ, BSJ)

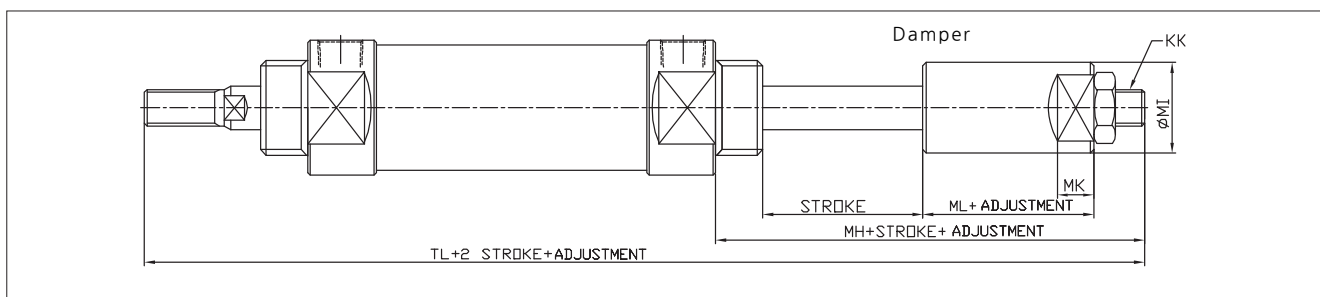

Unit:mm

Bore size	KK	MK	ØMI	MH	ML	TL
Ø20	M8X1.25	8	20	47	20	150
Ø25	M10X1.25	10	25	49	22	156
Ø32	M10X1.25	10	25	49	22	158
Ø40	M14X1.50	12	30	60	26	198

Dimensions-Single acting spring return (S), Single acting spring extend (T)

Single acting spring return

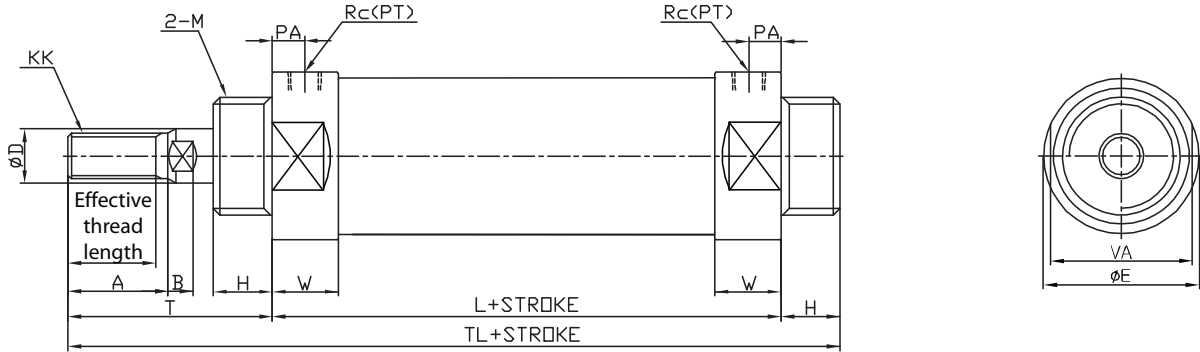

Single acting spring extend

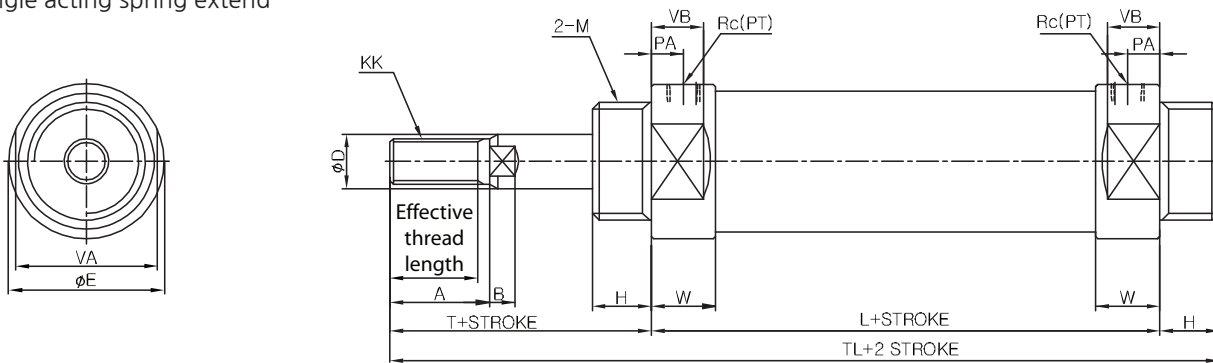

Unit:mm

Bore size	Effective thread length	A	B	ØD	E	H	KK	PA	Rc(PT)	T	VA	VB	W	M
Ø20	15.5	18	5	8	28	13	M8×1.25	8	1/8	41	24	12	15	M20×1.5
Ø25	19.5	22	5.5	10	34	13	M10×1.25	8	1/8	45	30	12	15	M26×1.5
Ø32	19.5	22	5.5	12	38	13	M10×1.25	8	1/8	45	32	12	15	M26×1.5
Ø40	21	24	7.5	14	50	16	M14×1.5	11	1/4	50	46	18	21	M32×2.0

Bore size \ Stroke	1~50		51~100		101~150		151~200		201~250	
	L	TL	L	TL	L	TL	L	TL	L	TL
Ø20	87	141	112	166	137	191	-	-	-	-
Ø25	87	145	112	170	137	195	-	-	-	-
Ø32	89	147	114	172	139	197	164	222	-	-
Ø40	113	179	138	204	163	229	188	254	213	279

Heat resistant cylinder (SV)

Heat resistant cylinder can be used at a high ambient temperature up to 150°C by equipped with heat-resistant seal.

Specifications

Type	Non-lubricated
Cylinder Bore size	Ø20, Ø25, Ø32, Ø40
Temperature	-20~150°C
Packing material	VITON

Stainless steel piston rod (SS)

Stainless steel cylinder rod is selected to prevent the end of rod from corrosion when it is in contact with water during operation.

Specifications

Type	Non-lubricated
Cylinder Bore size	Ø20, Ø25, Ø32, Ø40
Rod material	SUS 303

ACS4K series



Features

- Aluminum tube
- With built-in magnet
- With non-lubricated seal
- Improved bush decreases deflection and improves lateral load resistance
- Easy maintenance with screw fastening
- Rod seal is easy to be replaced
- A floating cushion seal is applied

How to Order

ACS4K - B 25 - S 150

① ② ③ ④ ⑤ ⑥ ⑦ ⑧ ⑨ ⑩

① Series

ACS4K	Rod Rotation Prevention Single Rod
ACS4WK	Rod Rotation Prevention Double Rod

② Mounting style

B	Standard	CD	Integrated clevis
LB	Foot	TR	Rod side trunnion
FA	Rod side flange	TH	Head side trunnion
FB	Head side flange		
CA	Single clevis		
CB	Double clevis		

③ Bore size

20	25	32	40
Ø20	Ø25	Ø32	Ø40

④ Cylinder stroke

Bore size	Standard stroke	Max. stroke
Ø20	25, 50, 75, 100, 125, 150, 175, 200, 250, 300	1000
Ø25		1500
Ø32		
Ø40		

※ Other intermediate strokes is available upon request.

※ Refer to page [1]-140, for Specification about custom-made rod ends.

⑤ Bellows

Type	Material	Max. ambient temperature
Nil	Without bellows	
J	Nylon Tarpaulin	60°C
K	Neoprene cloth	110°C

⑥ Rod end attachment

Nil	Rod end nut (Standard):1pc
I	Single knuckle joint
Y	Double knuckle joint

⑦ Auto switch

Reed A/S	Model	Solid State A/S	Model
C72	D-C72K	H7A1	D-H7A1K
C73	D-C73K	H7A2	D-H7A2K
C76	D-C76K	H7B	D-H7BK
C80	D-C80K		

※ Only for auto switch attached type.

※ Refer to page [10]-10, 19 for more information.

⑧ Number of auto switches

Nil	2 pcs
S	1 pc
N	N pcs (N: 3, 4, 5...)

※ Only for auto switch attached type.

⑨ Special order

Nil	None
TS	Multi-step stroke cylinder(Single rod)
TW	Multi-step stroke cylinder(Double rod)
ASJ	Stroke adjustable type (In forward direction within 25mm)
BSJ	Stroke adjustable type (In forward direction within 50mm)

⑩ Working format

Nil	Double acting cylinder
S	Single acting spring return
T	Single acting spring extend



Specifications

Bore size(mm)		Ø20	Ø25	Ø32	Ø40
Fluid		Air			
Proof pressure		15kgf/cm ² (1.5MPa)			
Max. operating pressure		10kgf/cm ² (1.0MPa)			
Min. operating pressure	Double acting, Single rod	0.5kgf/cm ² (0.05MPa)			
	Double acting, Double rod	0.8kgf/cm ² (0.08MPa)			
	Single acting return(S) / Single acting extend(T)	Return : 1.8kgf/cm ² (0.18MPa) / Extend : 2.3kgf/cm ² (0.23MPa)			
Ambient & fluid temperature		Without auto switch : -10~70℃(Without freezing) With auto switch : -10~60℃(Without freezing)			
Operating piston speed		Rubber cushion : 50~750mm/sec			
Cushion		Rubber cushion			
Tolerance of thread		~250ST : $\begin{matrix} +1.0 \\ 0 \end{matrix}$	251~1000ST: $\begin{matrix} +1.4 \\ 0 \end{matrix}$	1001~1500ST: $\begin{matrix} +1.8 \\ 0 \end{matrix}$	
Type		Non Lubricated			
Degree of non-rotating load		±0.7°	±0.6°		±0.5°
Allowable rotation torque(N·m Below)		0.2	0.25		0.44

Precautions for installation

1. When using a rod anti-rotation cylinder, avoid using the piston rod with rotational torque.
The non-rotating guide is deformed and the degree of non-rotation increases.
2. When mounting or dismounting the workpiece at the rod end, hold the spanner at the end of the piston rod with the piston rod fully retracted before use. At this time, tighten so that the tightening torque is not applied to the anti-rotation guide.

Small Cylinder (Aluminum Tube)-Rod Rotation Prevention Type

Dimensions-Standard (B)

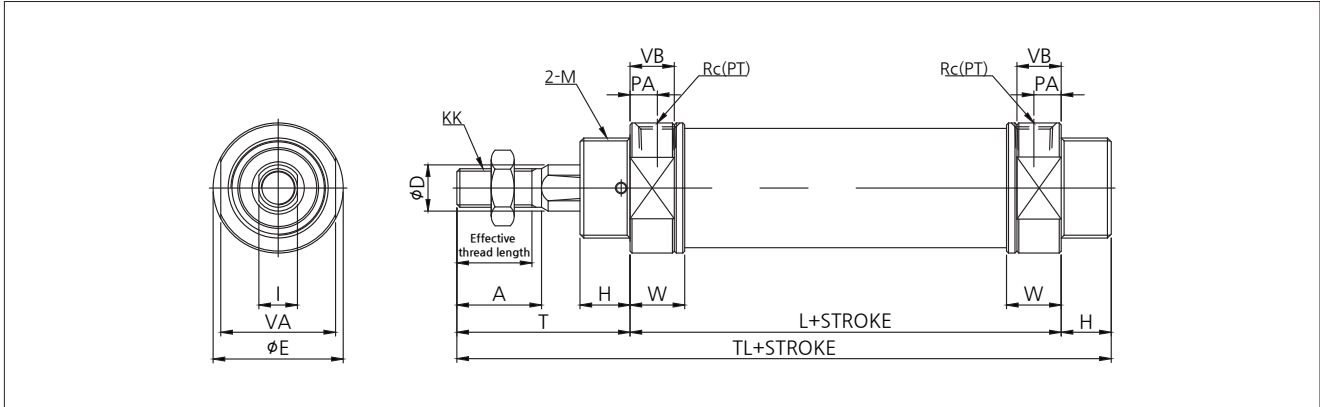

Unit:mm

Bore size	Effective thread length	A	ØD	ØE	H	I	KK	L	M	PA	Rc(PT)	T	TL	VA	VB	W
Ø20	15.5	18	8	28	13	8	M8X1.25	62	M20X1.5	7	1/8	41	116	24	12	14.2
Ø25	19.5	22	10	34	13	10	M10X1.25	62	M26X1.5	7	1/8	45	120	30	12	14.2
Ø32	19.5	22	12	38	13	10	M10X1.25	64	M26X1.5	7.5	1/8	45	122	32	12	14.5
Ø40	21.0	24	14	50	16	14	M14X1.50	88	M32X2.0	11	1/4	50	154	46	18	21

※ The external dimensions of the piston rod are the same as those of the standard cylinder (refer to the standard cylinder for external dimensions)

Dimensions-Double rod (W)

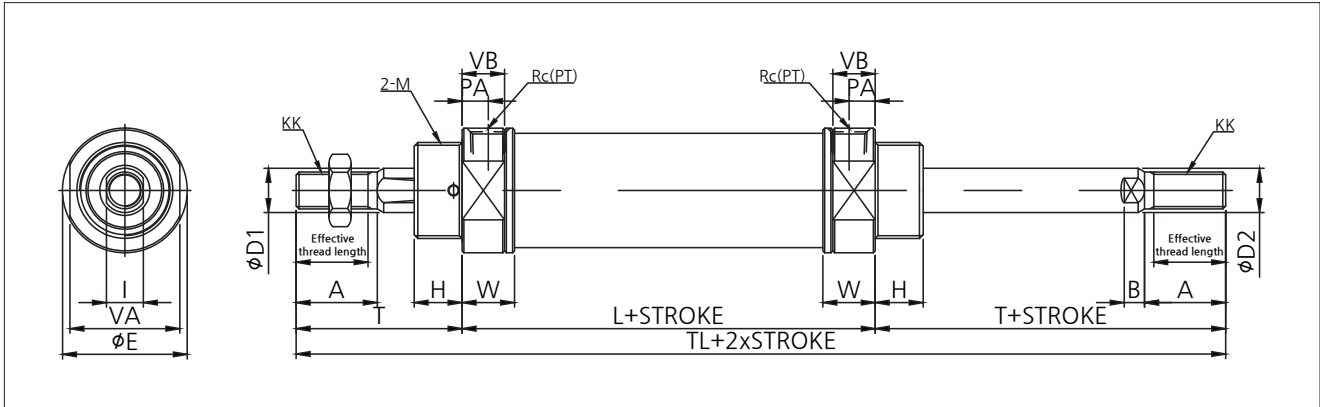

Unit:mm

Bore size	Effective thread length	A	B	ØD1	ØD2	ØE	H	I	KK	L	M	PA	Rc(PT)	T	TL	VA	VB	W
Ø20	15.5	18	5.0	10	8	28	13	8	M8X1.25	62	M20X1.5	7	1/8	41	116	24	12	14.2
Ø25	19.5	22	5.5	12	10	34	13	10	M10X1.25	62	M26X1.5	7	1/8	45	120	30	12	14.2
Ø32	19.5	22	5.5	12	12	38	13	10	M10X1.25	64	M26X1.5	7.5	1/8	45	122	32	12	14.5
Ø40	21.0	24	7.5	14	14	50	16	14	M14X1.50	88	M32X2.0	11	1/4	50	154	46	18	21

※ The external dimensions of the piston rod are the same as those of the standard cylinder (refer to the standard cylinder for external dimensions)