

# *Opel Astra*



## Electronic Workshop Manual



# Opel Astra Opel Kadett

## Workshop Manual

- A — MAINTENANCE, BODY AND CHASSIS SHEET METAL PARTS
- B — PAINT
- C — BODY EQUIPMENT
- D — HEATING AND VENTILATION SYSTEM, AIR CONDITIONING
- E — FRAME, FRONT WHEEL SUSPENSION, WHEELS AND TYRES
- F — REAR AXLE AND REAR WHEEL SUSPENSION
- H — BRAKES
- J — ENGINE AND ENGINE AGGREGATES
- K — CLUTCH AND TRANSMISSION
- L — FUEL AND EXHAUST SYSTEM, EXHAUST EMISSIONS TEST
- M — STEERING
- N — ELECTRICAL EQUIPMENT AND INSTRUMENTS
- R — OPTIONAL EQUIPMENT, ACCESSORIES

# DEFINITION OF PROCEDURES

<b>Remove, Disconnect</b>	Any form of removal on vehicle (unbolt, drive out, etc.)	<b>Inspect</b>	Check component for function and wear
<b>Install, Connect</b>	Any form of installation on vehicle (bolt on, fit, etc.)	<b>Measure</b>	Measure component to check that it conforms to specified values
<b>Disassemble</b>	Disassemble component for cleaning, checking, etc.	<b>Adjust</b>	All adjustment operations involving specified values
<b>Assemble</b>	Assemble component after completion of function check	<b>Tighten (Torque)</b>	Tighten bolts or nuts to prescribed torque
<b>Clean</b>	To guarantee function or reduce wear (bearing surface, sealing surface, etc.)	<b>Torque — Angle Method</b>	Tighten bolts or nuts to prescribed torque and tighten further
		<b>Note, Warning, Caution</b>	Safety regulations or important notes

## Lifting Points for Lifting Equipment

To raise the vehicle, lifting tools may be placed only at the points indicated.

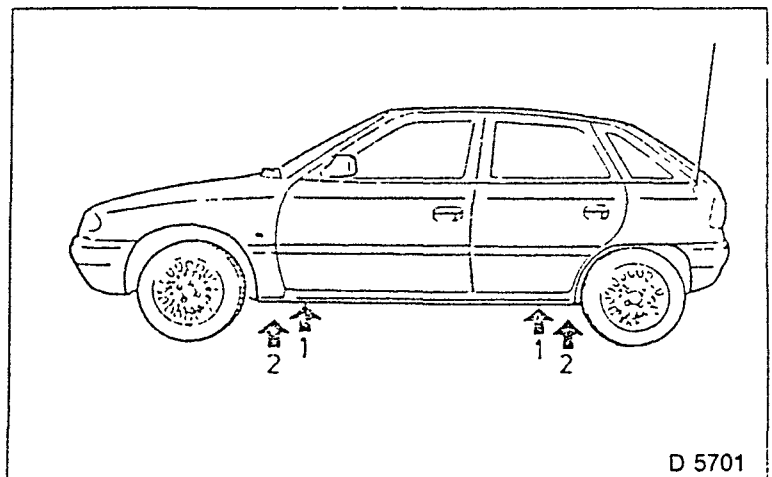
If these exact positions are not used, permanent body deformation may be caused.

Rubber pads must be used on the lifting arms.

Under no circumstances must the vehicle be lifted at engine parts, transmission or rear axle.

1 — Lifting point for vehicle jack

2 — Lifting point for lift and floor jack.



# SAFETY NOTICE

Proper maintenance and repair is very important for the safe and reliable functioning of all motor vehicles. The service procedures recommended by the Delta Motor Corporation and contained in these Service Instructions are effective methods of carrying out maintenance and repair. Some of these operations require the use of tools specially designed for a particular purpose. These special tools should be used as and when recommended.

Service Instructions and Technical Information Bulletins belong in the hands of supervisors and mechanics, as they must be constantly referred to and carefully followed to ensure that the vehicle is maintained in a safe condition.

It is expressly requested that the warning and safety measures contained in these Service Instructions be read and followed with care in order to minimize the risk of personal injury to service personnel and to eliminate the possibility of damaging the vehicle or rendering it unsafe.

When carrying out operations which involve the possibility of an electrical short circuit, the ground strap must be disconnected from the battery. This also applies when the vehicle is being electrically welded.

Disconnection of the ground strap automatically erases the contents of the memories of the electronic systems. Electrical systems such as the board computer clock, the window winder electronics and the stations stored in the radio, should be reprogrammed as far as possible, when the ground strap is reconnected.

**WARNING:** The fan is controlled by a thermostatic switch and may consequently start to operate unexpectedly.

These warnings and precautions are not exhaustive. Delta Motor Corporation cannot possibly foresee and evaluate all the conceivable ways in which maintenance and repair might be carried out or the possible hazardous consequences of each method.

It is important that anyone who uses a service procedure or tool, which is not recommended, first satisfies himself thoroughly that neither his own safety nor vehicle safety will be jeopardized by the service method he selects.

Attention is drawn to the fact that all work in connection with the following service operations should only be carried out in accordance with the pertinent rules and instructions of the local trade or similar association, in particular the accident prevention regulations.

The legal requirements for the safety of vehicles on the road must be complied with.

Laws relating to environmental protection and to health should be equally observed.

The contents of these Service Instructions are based on latest product information available at the time of publication. Delta Motor Corporation (Pty) Ltd., expressly reserves the right to make alterations in the technical details of the vehicles in the data, illustrations and Service Instructions.

**Opel Astra**  **Opel Kadett**

## **Workshop Manual**

### **Section A**

# **Maintenance, Body and Chassis Sheet Metal Parts**

Issued by: Service Division  
Delta Motor Corporation  
July, 1993

# Index

*Page*

## Body and Chassis Sheet Metal Parts

BODY DIMENSION CHART.....	A- 8
BODY DIMENSION TABLE .....	A-14
BODY REPAIR USING CEMENTING ..	A- 4
BODY REPAIR WITH STRAIGHTENING BENCHES. ....	A- 5
GENERAL INSTRUCTIONS .....	A- 3
LEGEND FOR WELDING OPERATIONS .....	A- 6
WELDING SEAMS.....	A- 6

## Trim Panels, Trim Panel Parts, Spoiler

COWL PANEL, REMOVE AND INSTALL.....	A-18
FRONT PANELLING, REMOVE AND INSTALL. ....	A-15
FRONT PANELLING, REPLACE.....	A-16
OUTER B PILLAR PANEL, REMOVE AND INSTALL. ....	A-20
RADIATOR GRILLE, REMOVE AND INSTALL.....	A-17
REAR PANELLING, REMOVE AND INSTALL (ASTRA) .....	A-21
REAR PANELLING, REMOVE AND INSTALL (KADETT).....	A-20
REAR SPOILER, INSTALL (ASTRA) .....	A-23
REAR SPOILER, REMOVE AND INSTALL (KADETT) (200iS & 200ts). ....	A-22
REAR SPOILER, REMOVE AND INSTALL (KADETT).....	A-21
STONE PROTECTOR, REMOVE AND INSTALL .....	A-19
TAILGATE TRIM STRIP, REMOVE AND INSTALL (KADETT) (200iS & 200ts).....	A-25
WHEEL WELL INNER PANELLING, REMOVE AND INSTALL.....	A-17

## Sheet Metal Parts (Bolted)

BONNET, BONNET FUNCTIONING PARTS, REMOVE AND INSTALL . . .	A-27
BONNET HINGE, REPLACE .....	A-28
HINGE BOW, LUGGAGE COMPARTMENT LID, REPLACE (ASTRA).....	A-30
LUGGAGE COMPARTMENT LID, REMOVE AND INSTALL (ASTRA) .....	A-30
TAILGATE, REMOVE AND INSTALL.....	A-29
WING, REMOVE AND INSTALL.....	A-26

## Sheet Metal Parts (Welded)

A PILLAR, REPLACE .....	A-37
AIR DEFLECTOR PANEL ASSEMBLY, REPLACE COMPLETELY.....	A-33
AIR DEFLECTOR PANEL ASSEMBLY, REPLACE PARTIALLY.. . . .	A-34
B PILLAR, REPLACE ... ..	A-39
CONTROL ARM BRACE — FRONT FRAME SIDE MEMBER, REPLACE.. ..	A-37
DOOR SILL PANELLING, REPLACE ... ..	A-40
FRONT MEMBER (RADIATOR CROSSMEMBER), REPLACE .....	A-32
FRONT MEMBER (RADIATOR CROSSMEMBER), REPLACE PARTIALLY .. ..	A-32
FRONT MEMBER CENTRE, REPLACE .....	A-33
FRONT WHEEL WELL, REPLACE COMPLETELY .....	A-35
LOWER REAR END PANEL, REPLACE COMPLETELY (KADETT) . . . . .	A-49
LOWER REAR END PANEL, REPLACE COMPLETELY (ASTRA) ... ..	A-50
LOWER REAR END PANEL, REPLACE PARTIALLY (KADETT).....	A-50
LOWER REAR END PANEL, REPLACE PARTIALLY (ASTRA) ... . . . .	A-51
OUTER PANELLING — DOOR, REPLACE .. . . . .	A-41
OUTER PANELLING, TAILGATE, REPLACE .....	A-41
REAR QUARTER PANEL, REPLACE (KADETT). . . . .	A-43
REAR QUARTER PANEL, REPLACE (ASTRA) . . . . .	A-44
REAR QUARTER PANEL, REPLACE PARTIALLY (ASTRA) . . . . .	A-45
REAR SECTION OF INNER REAR QUARTER PANEL, REPLACE PARTIALLY (KADETT) .. . . .	A-46
REAR SECTION OF INNER REAR QUARTER PANEL, REPLACE PARTIALLY (ASTRA).. . . . .	A-47
REAR SIDE MEMBER ENDS, REPLACE BOTH (KADETT) . . . . .	A-52
REAR SIDE MEMBER ENDS, REPLACE BOTH (ASTRA) .. . . . .	A-53
ROOF PANELLING, REPLACE (KADETT) ... . . . .	A-54
ROOF PANELLING, REPLACE (ASTRA)... . . . .	A-55
SIDE BRACKET FOR FRONT PANELLING, REPLACE .....	A-35
WHEEL WELL AND FRONT FRAME SIDE MEMBER, REPLACE PARTIALLY .....	A-36

<b>Special Service Tools</b> .....	A-56
------------------------------------	------

# BODY AND CHASSIS SHEET METAL PARTS

## General Instructions

Before beginning work on body sheet metal parts, remove body attaching parts, assemblies or fittings which interfere with the work. Disconnect battery ground strap

After carrying out repair work on the body, ensure that the ground connections are correct. Poor ground connections lead to faults in the system and, in extreme cases, to destruction of the control unit.

The appropriate guidelines and regulations related to fire and accident prevention are to be followed in connection with welding or grinding work on the body

The same attention is to be devoted to following the environmental protection and health regulations.

### NOTE:

**SINCE LEGAL PROVISIONS DIFFER IN INDIVIDUAL COUNTRIES, IT IS NOT POSSIBLE TO INCLUDE LEGAL PROVISIONS DETAILS IN THE WORKSHOP LITERATURE. IT IS THE INDIVIDUAL'S RESPONSIBILITY TO OBTAIN AND OBSERVE THE RESPECTIVE REQUIREMENTS.**

The section repairs shown in the operations are the result of extensive tests.

The welding procedures appearing in the various operations are identified with welding symbols.

There is basically no difference between the welding of body untreated deep drawn sheet metal and alloy-galvanized sheet metal. Alloy-galvanized sheet metal should preferably be spot welded.

Remove all paint layers completely from spot weld flanges.

Use corrosion protection measures and corrosion protection materials from the Parts and Accessories Department.

During any separation operations, grinding operations or welding operations, ensure that a suitable device for removing vapour is present.

Operations in this group are, on the whole, described and illustrated on left-hand drive vehicles. The operation processes on right-hand vehicles are generally a mirror image and analogous. The functions of the various systems are the same on both left-hand and right-hand drive vehicles. Any basic deviations are accompanied by the appropriate information.

The illustrated cutting sections and/or cutting lines are the result of comprehensive crash tests and examinations of vehicles which have been involved in accidents. Body sheet metal parts and body members (underbody) are made of cold-workable, deep drawn sheet steel in standard production. Consequently damaged parts must be cold when restoring them to their original shape.

No reference is made in these labour operations to continually recurring standard operations, such as separation of parts or grinding mating surfaces, as these should be known sufficiently well in the service workshops.

If the degree of damage does not permit restoration of the original shape, first straighten the mating surfaces. The damaged body section can then be replaced.

The repair methods specified in this group must be used in those areas where both cutting and joining would have an effect on the strength and safety of the body.

When delivered to the Paint shop, the surface of the body parts must be satisfactorily prepared for painting. The surface is paintable when damaged sheet metal parts have been repaired (dents removed, seams welded and soldered, overlapping seams in cases of partial replacement) in such a way that the paint shop does not need to apply more than three thin filler coats.

These operations belong to the sheet metal worker's working area and should be included in his specified repair time.

After accidents indicating considerable stress on the chassis, the following components in particular should be checked, independently of checking axle alignment, which should be carried out in all cases:

Check steering and steering linkage for correct operation through the complete turning circle, check visually for deformation and cracks.

Check all components of the chassis for deformation and cracks, including spring strut, steering knuckle, control arm, axle body and stabilizer and their fastening parts.



Test wheel rims and tyres for damage, examine tyres for cuts in the tread and the side walls and check for true running and balance.

## **SAFETY MEASURES:**

- Disconnect battery from vehicle electrical system.
- Install ground cable of welding equipment immediately beside point to be welded.
- Control units can be damaged at temperatures above 60°C/140°F.
- During removal/installation operations on the engine or transmission, ensure that all ground connections are correctly routed. If the engine is started although the ground connections are incomplete, the control units can be destroyed.

## **BODY REPAIR USING CEMENTING**

“Cementing” means joining of the same or different materials using an anorganic or organic substance at room temperature or with slight heating. Practical use of the cementing technique is limited to body components which do not bear a load (e.g. outer rear quarter panel). Load-bearing components, e.g. frame, members must not be cemented.

Using the previously employed repair method, welding in new sheet metal parts, an assortment of interior parts sensitive to fire and heat, e.g., inner trim panelling, seats, fuel tank, etc., had to be removed. The cementing method means a reduction in the amount of time required for the repair operations.

The cementing technique has a series of advantages compared to the welding process:

- Bond is free of tension.
- No change in material jointing.
- Maintenance of standard corrosion protection.
- Water-tight and corrosion-free joint. No electrochemical corrosion between different materials.
- Universal application. The cementing technique can be used after a short period of instruction.

A precondition for a stable bond which can tolerate the forces present in the bonded area is, besides exact observation of the processing instructions of the cement manufacturer, proper preparation and positioning of the joint surfaces and joining parts.

The joint surfaces shape which has been proven itself to be the most efficient in bodyworking and in repairs is the offset overlap with tapered upper plate, which is the preferred method.

The adhesion of the cement bond depends on the inner bonding force of the cement and of the bonding force between the cement layer and the surface of the parts being bonded. The specific properties of the cement and the condition of the surface of the parts being joined is important.

Thorough cleaning of the joining parts in the area to be cemented is a precondition for a stable cemented bond.

Any grease and wax remains, oxide layers, rust, scales, paint and primer must be completely removed from the surfaces being cemented.

For degreasing, only the solvent included in the repair set “TWO COMPONENT CEMENT (REPAIR PACKAGE) FOR CEMENTING OF BODY SHEET METAL” may be used.

### **WARNING:**

**NEVER USE ALCOHOL, BENZINE OR PAINT THINNER.**

In areas where the new component cannot be fixed with clamps until the cement has hardened, steel flat-headed blind rivets — type 4 X 8 mm, must be used. The rivets transfer practically no force but serve only to hold the new component firmly in place while the cement is hardening.

The further development of cementing materials has already made it possible to spot weld the cement area while it is still wet, instead of using rivets (not plug welding or seam welding).

The “TWO COMPONENT CEMENT (REPAIR PACKAGE) FOR CEMENTING OF BODY SHEET METAL” intended for cementing body components, is designed for the special requirements of body repairs and must only be used in the prescribed combination. It must **NEVER** be replaced by or mixed with other unauthorized materials.

When using two component cement based on epoxy resin, observe the processing instructions and safety measures of the manufacturer and relevant institutional regulations. When processing cementing materials, special safety measures must be observed in order to avoid damage to health.

The same restrictions apply here as for paint materials.

Avoid direct skin contact with cements. Unhardened epoxy resin cement can cause irritations on sensitive skin.

If cement comes into contact with skin, wash immediately with warm water and soap. Rub in skin protection cream. If cement spray gets into the eyes, wash out immediately with plenty of luke-warm water for 10 to 15 minutes. Contact an eye specialist.

## **BODY REPAIR WITH STRAIGHTENING BENCHES**

All work on supporting parts, frames and wheel well components are carried out on straightening benches

# LEGEND FOR WELDING OPERATIONS

Process:

RP = Resistance Spot Welding

SG = Shielded Arc Welding

MIG (inert gas metal arc)

MAG (Active gas metal arc)

Brazing

1 = Spot welding tongs

2 = Shielded arc welding unit

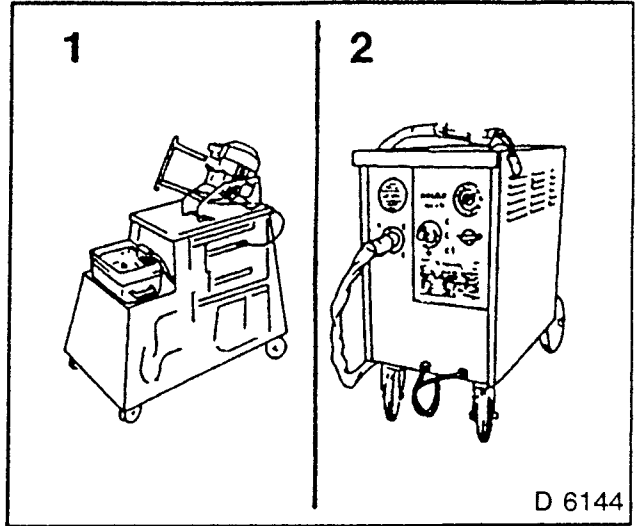


Fig. 1

Symbols:

1 — Resistance spot welding

2 — Plug spot welding

3 — Stitch seam spot welding

4 — Full seam

5 — Full seam, broken

6 — Brazing

8 — Number of spot welds

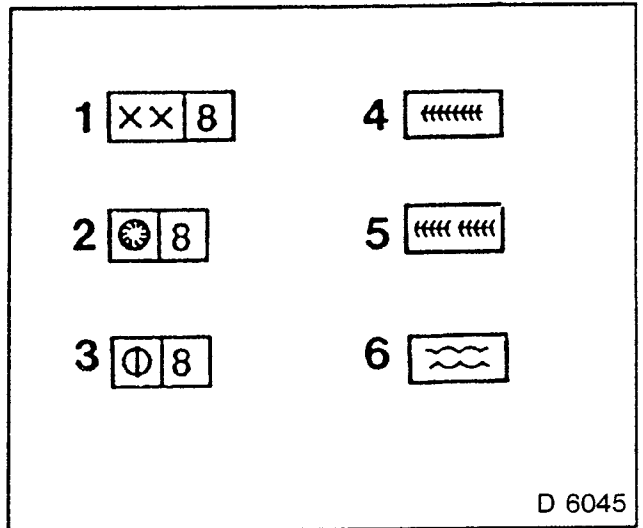


Fig. 2

## Welding Seams

### 1 — RESISTANCE SPOT WELDING

NOTE:

THE ELECTRODE PRESSURE REQUIRED FOR RESISTANCE SPOT WELDING WITH HAND SPOT WELDING TONGS IS NOT ADEQUATE WITH WELDING TONGS WITH A LENGTH OF OVER 40 cm.

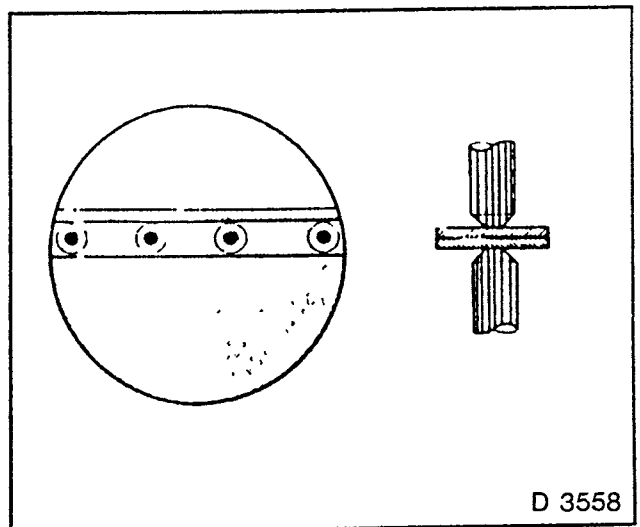


Fig. 3

**2 — PLUG SPOT WELDING**

1 — Overlapped

2 — Offset

a = 10 — 14 mm

b = 6 mm hole diameter with 0.75 mm or  
0.88 mm plates

7 mm hole diameter with 1.50 mm plates

c = 20 — 40 mm

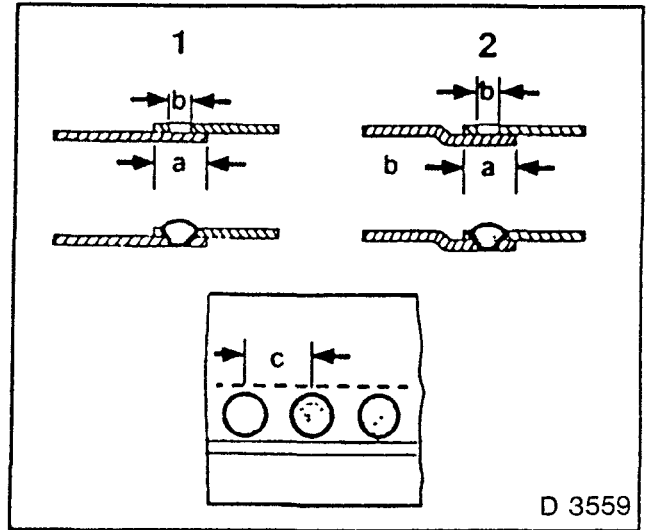


Fig. 4

**3 — STITCH SEAM SPOT WELDING**

1 — Overlapped

2 — Offset

a = 10 — 14 mm

b = 3 — 5 mm

c = 20 — 40 mm

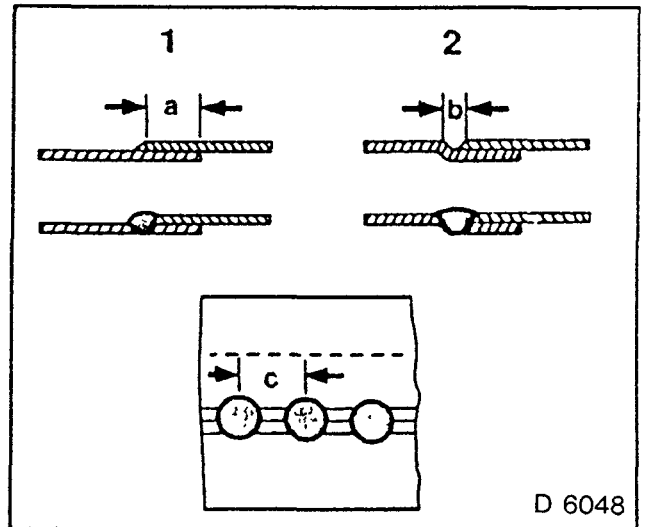


Fig. 5

**4 — FULL SEAM**

1 — Butt welded

2 — Overlapped

3 — Offset

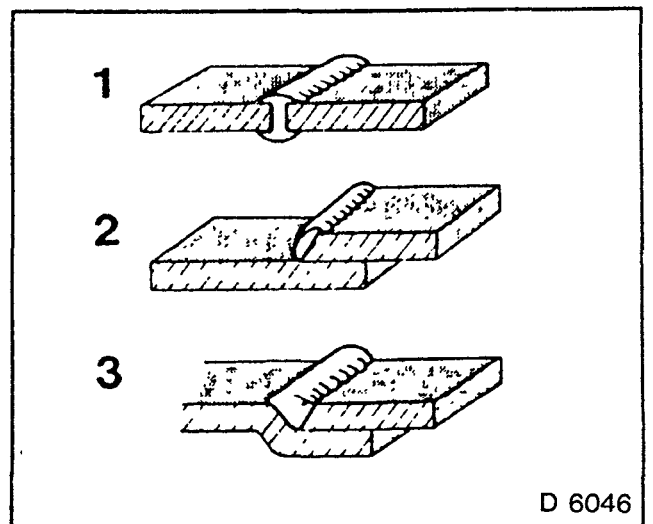


Fig. 6

D 6046

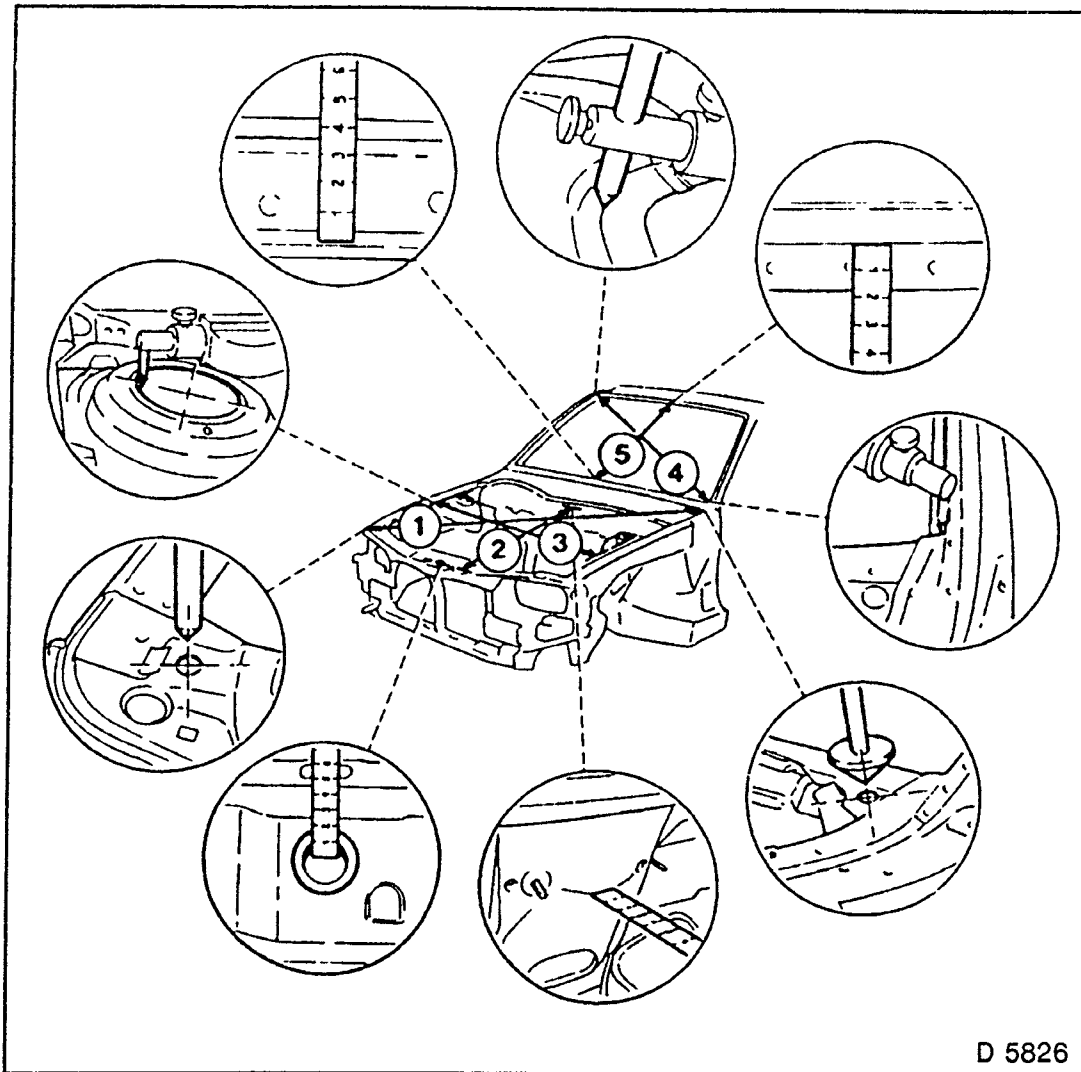
# BODY DIMENSION CHART

Observe precisely the body dimension chart when replacing welded sheet metal components

All dimensions without tolerances =  $\pm 2$  mm

## ALL MODELS

Pos	Dimensions in mm
1	1 573
2	805
3	1 138
4	1 364
5	740



D 5826

Fig. 7

**ASTRA & KADETT**

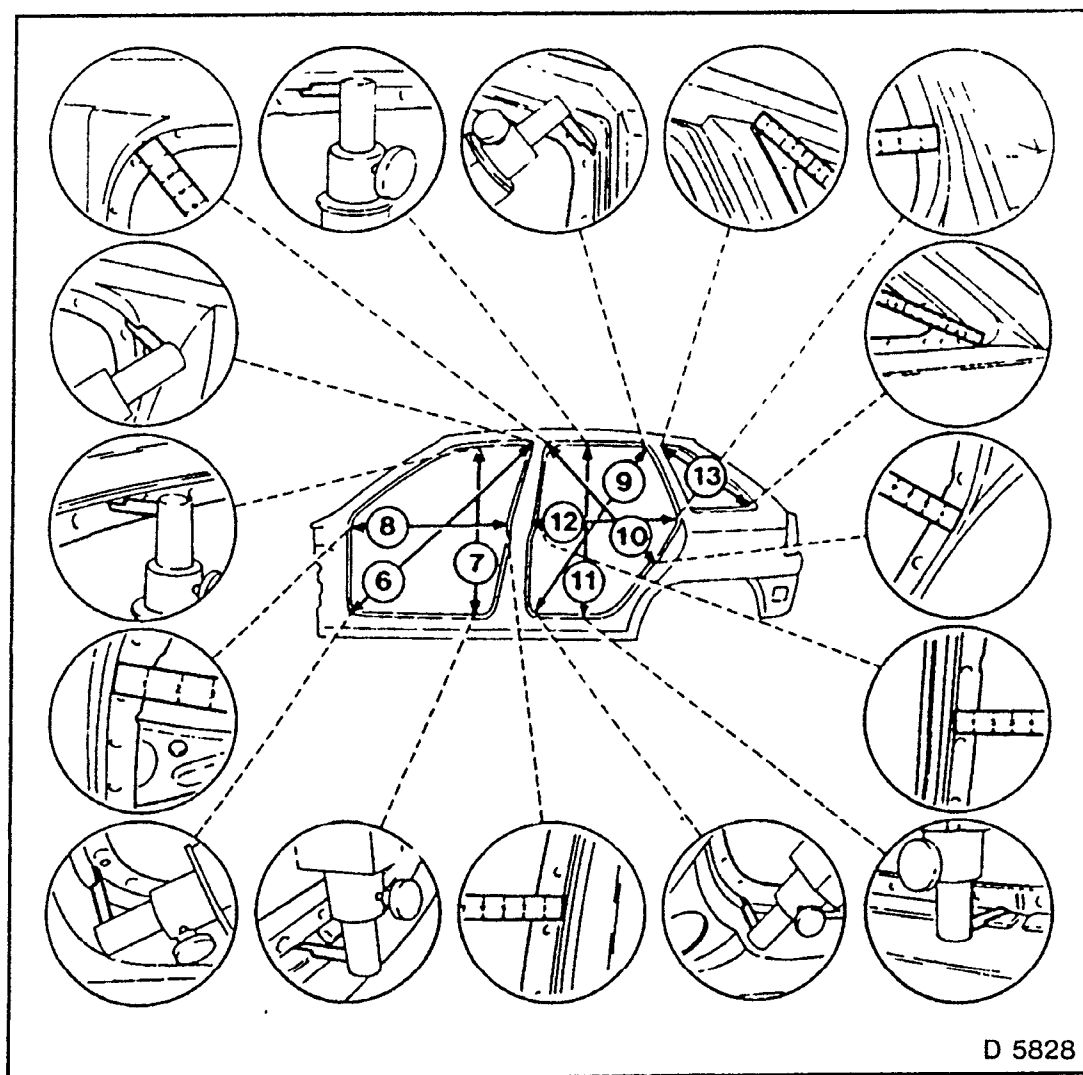
Pos.	Dimensions in mm
6	1 344
7	984
8	890
9	1 154
10	905
11	1 001
12	818

**ASTRA**

Pos	Dimensions in mm
13	615

**KADETT**

Pos.	Dimensions in mm
13	679



D 5828

Fig. 8

**KADETT**

Pos.    Dimensions  
      in mm

29        1 240

30        895

31        962

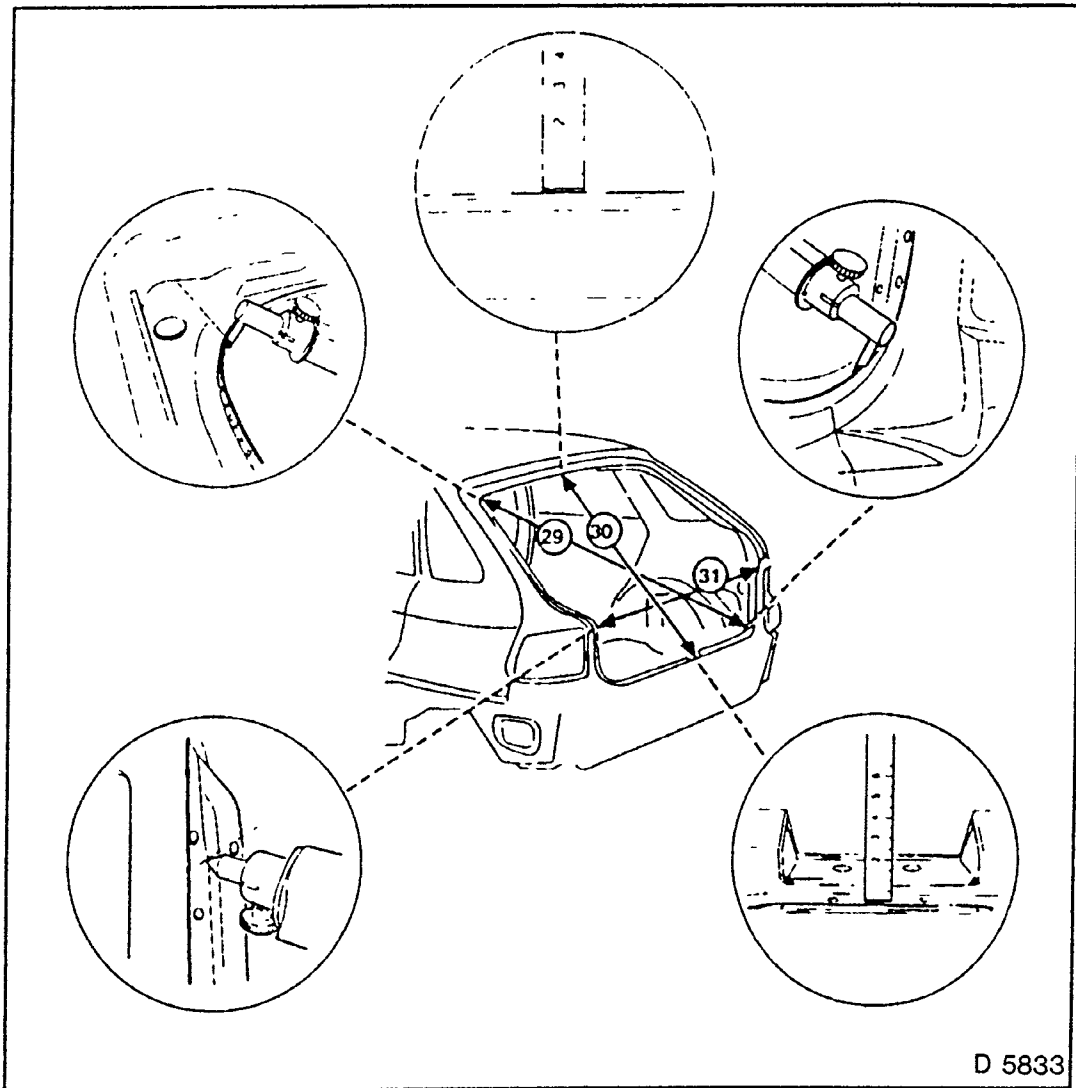


Fig. 9

**ASTRA**

Pos.	Dimensions in mm
36	1 082
37	505
38	1 215

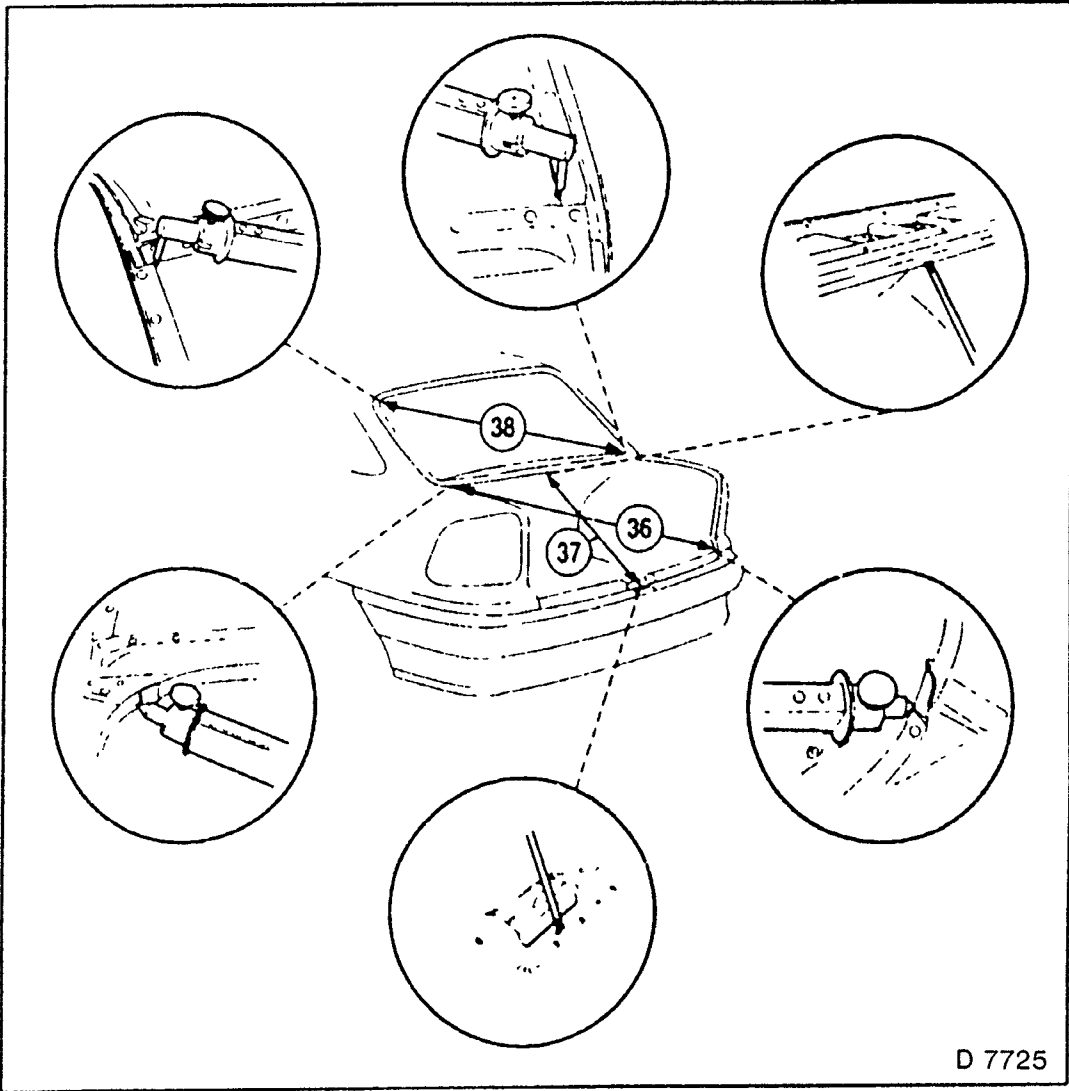
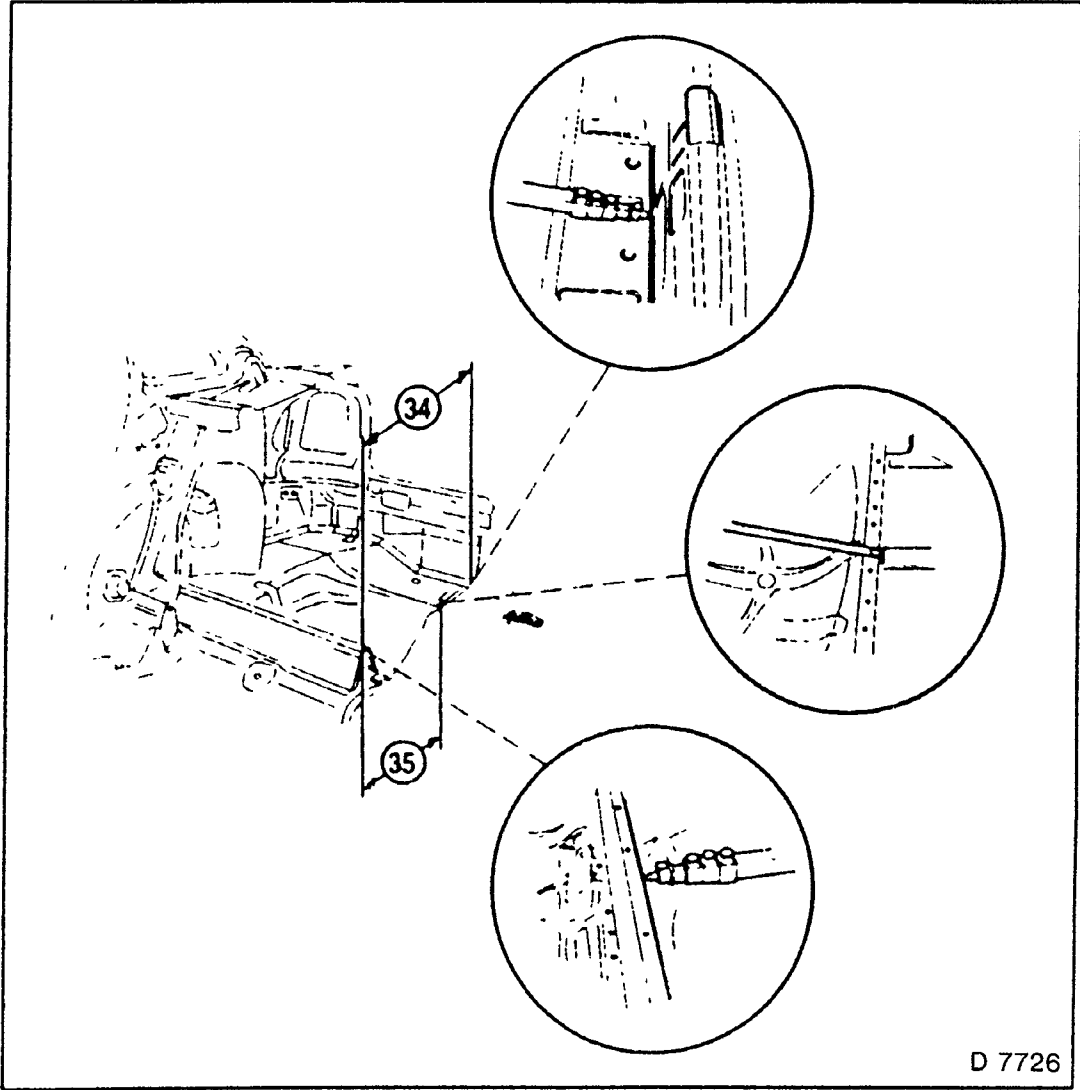


Fig. 10



**ASTRA**

Pos.	Dimensions in mm
34	945
35	777



D 7726

Fig. 11

**ASTRA & KADETT**

Pos.	Dimensions in mm
32	1 038

**ALL MODELS**

Pos.	Dimensions in mm
33	1 316

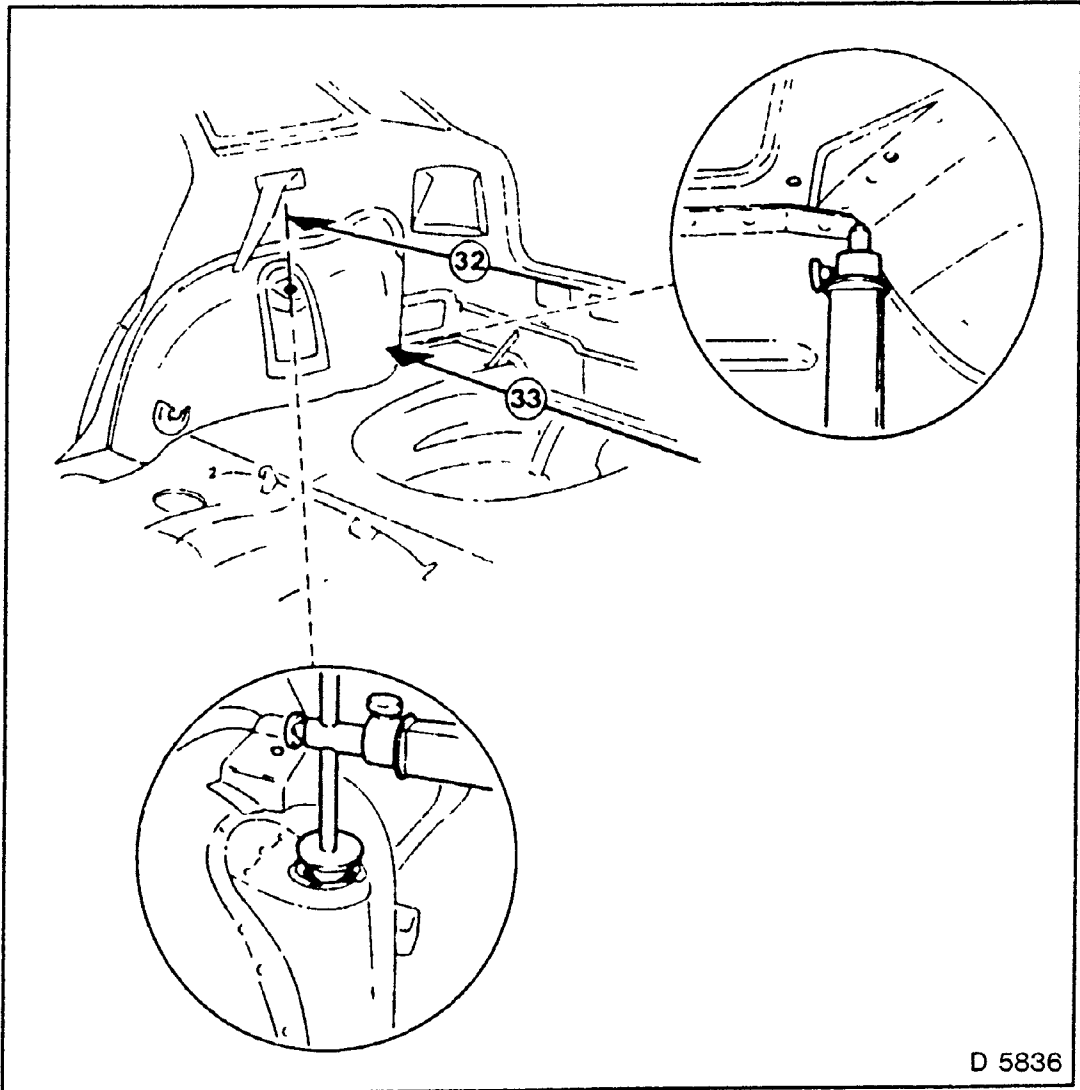


Fig. 12

## BODY DIMENSION TABLE

Pos.	DESCRIPTION, Measured Section	ASTRA	KADETT
		Dimensions in mm	
1	Diagonal of engine compartment opening	1 573	
2	Depth of engine Compartment (centre bonnet locking bolt)	805	
3	Width between both spring strut domes (outer edge of hole)	1 138	
4	Diagonal of windscreen frame	1 364	
5	Height of windscreen frame	740	
6	Diagonal of front door frame	1 344	1 344
7	Height of front door frame	984	984
8	Opening of front door frame (A to B pillar)	890	890
9	Diagonal of rear door frame (long)	1 154	1 154
10	Diagonal of rear door frame (short)	905	905
11	Height of rear door frame (centre of sill)	1 001	1 001
12	Opening of rear door frame	818	818
13	Diagonal of frame — rear quarter window	615	679
14	Height of frame — rear quarter window (centre)	—	—
17	Distance between both A pillars (upper)		970
18	Distance between both B pillars (upper)		960
19	Distance between both C pillars (upper)	950	950
20	Distance between both D pillars (upper)	—	—
21	Distance between both A pillars (door stop bracket)		1 366
22	Distance between both B pillars (door stop bracket)		1 376
23	Distance between both C pillars (at height of door lock bolt)	1 332	1 332
24	Distance between both A pillars (lower)		1 410
25	Distance between both B pillars (lower)		1 378
26	Distance between both C pillars (lower)	1 405	1 405
27	Distance between frame of rear side window (rear corner)	1 345	1 345
28	Diagonal of upper B pillar to lower B pillar		1 580
29	Tailgate diagonal opening	—	1 240
30	Tailgate opening height	—	895
31	Width of rear quarter panel ends (at height of rear lamps)	—	962
32	Distance between both shock absorber mountings (centre of hole)	1 038	1 038
33	Width between inner quarter panels (end of wheel housing)		1 316
34	Depth of luggage compartment floor	945	790
35	Depth of luggage compartment floor (crossmember to butt joint overlap)	777	—
36	Diagonal of luggage compartment lid opening	1 082	—
37	Depth of luggage compartment lid opening	505	—
38	Diagonal of rear screen frame opening	1 215	—

All dimensions in mm without tolerances. Tolerance  $\pm 2$  mm. All dimensions reference points which are not shown in detail are based on the body ridges or sealing flanges.

### NOTE:

A pillar = Hinge pillar of front door — All Models

C pillar = Lock pillar of rear door — Kadett

B pillar = Lock pillar of front door — All Models

D pillar = Side roof extension and frame of tailgate

## TRIM PANELS, TRIM PANEL PARTS, SPOILER

### Front Panelling — Remove and Install

#### REMOVE, DISCONNECT

1. Front panelling.
2. From side member — Two nuts.
3. From side bucket — Four bolts
4. From wheel housing inner panelling — Four bolts.
5. With heavy version "Front Member (Radiator Crossmember)" — Four body-bound rivets.

#### INSTALL, CONNECT

1. Front panelling.

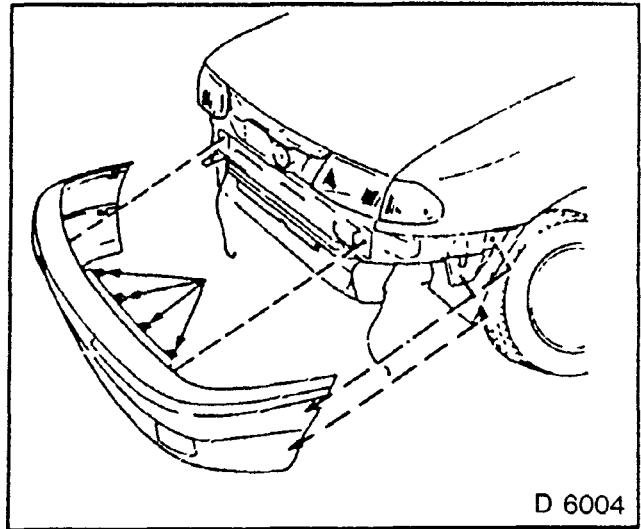


Fig. 13

## Front Panelling — Replace

Only work that deviates from the operation "Front Panelling, Remove and Install" is described.

### REMOVE, DISCONNECT

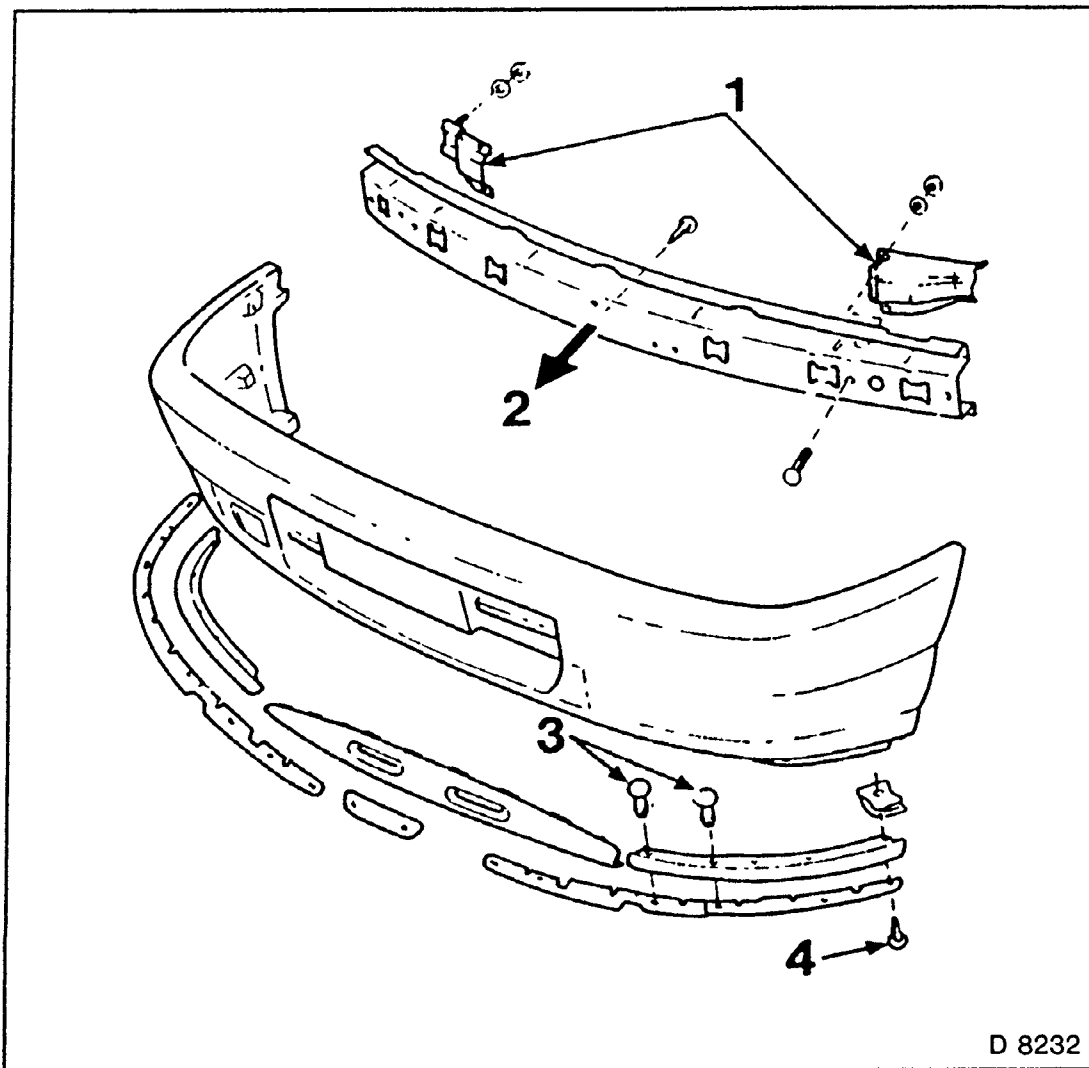
- 1 Front panelling.

### ASSEMBLY

- 1 = Brackets to support, two bolts each
- 2 = Support to front panelling, eleven bolts.
- 3 = Assemble front panelling extensions and reinforcement, four body-bound rivets.
- 4 = Bolts on extension to front panelling, fourteen bolts.

### INSTALL, CONNECT

1. Front panelling.



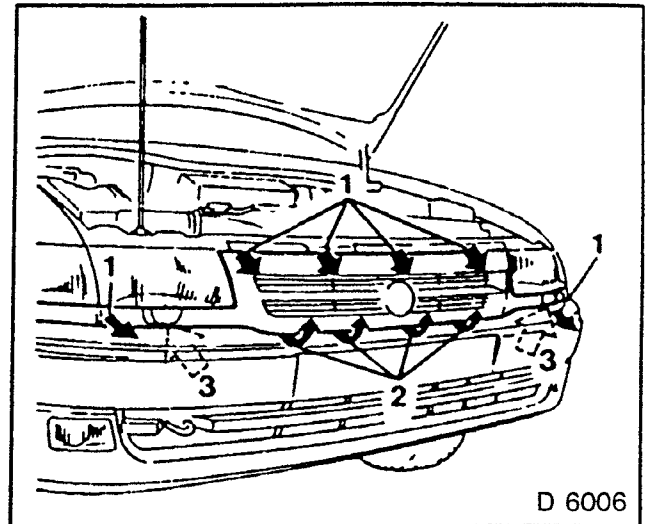
D 8232

Fig. 14

## Radiator Grille, — Remove and Install

### REMOVE, DISCONNECT

- 1 = Pull radiator grille forwards out of retaining lugs.
- 2 = Pull lower bracket upwards out of front panelling.
- 3 = Disconnect headlamp cleaner hose (if present).

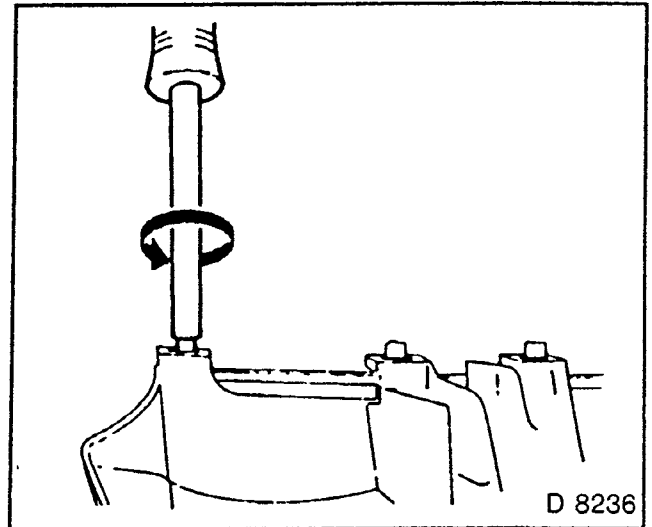


D 6006

Fig. 15

### INSTALL, CONNECT

1. After painting, place grille in radiator grille.
2. Bond plastic pins by screwing with KM — 205.
3. Apply seal lips.
4. Radiator grille.



D 8236

Fig. 16

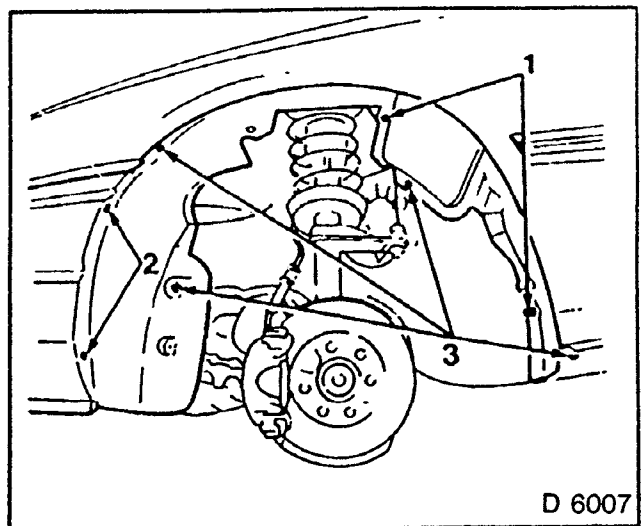
## Wheel Well Inner Panelling — Remove and Install

### REMOVE, DISCONNECT

- 1 Wheel well inner panelling.
  2. Two plastic nuts (1).
  3. Two bolts (2).
  4. Four body-bound rivets (3).
- Fig. 17 indicates wheel removed.

### INSTALL, CONNECT

1. Wheel well inner panelling — use new plastic nuts.



D 6007

Fig. 17

## Cowl Panel, — Remove and Install

### REMOVE, DISCONNECT

- 1 = Windscreen wiper arms.
- 2 = Rubber seal.
- 3 = Water deflector.
- 4 = Cowl panel.
- 5 = Two cover caps, two bolts.
- 6 = Two plastic nuts.
- 7 = Two velcro strips.

### INSTALL, CONNECT

- 1. Cowl panel.
- 2. Place paper strips between velcro strips as installation aid. Remove after installation.
- 3. Water deflector.
- 4. Rubber seal.
- 5. Windscreen wiper arms.

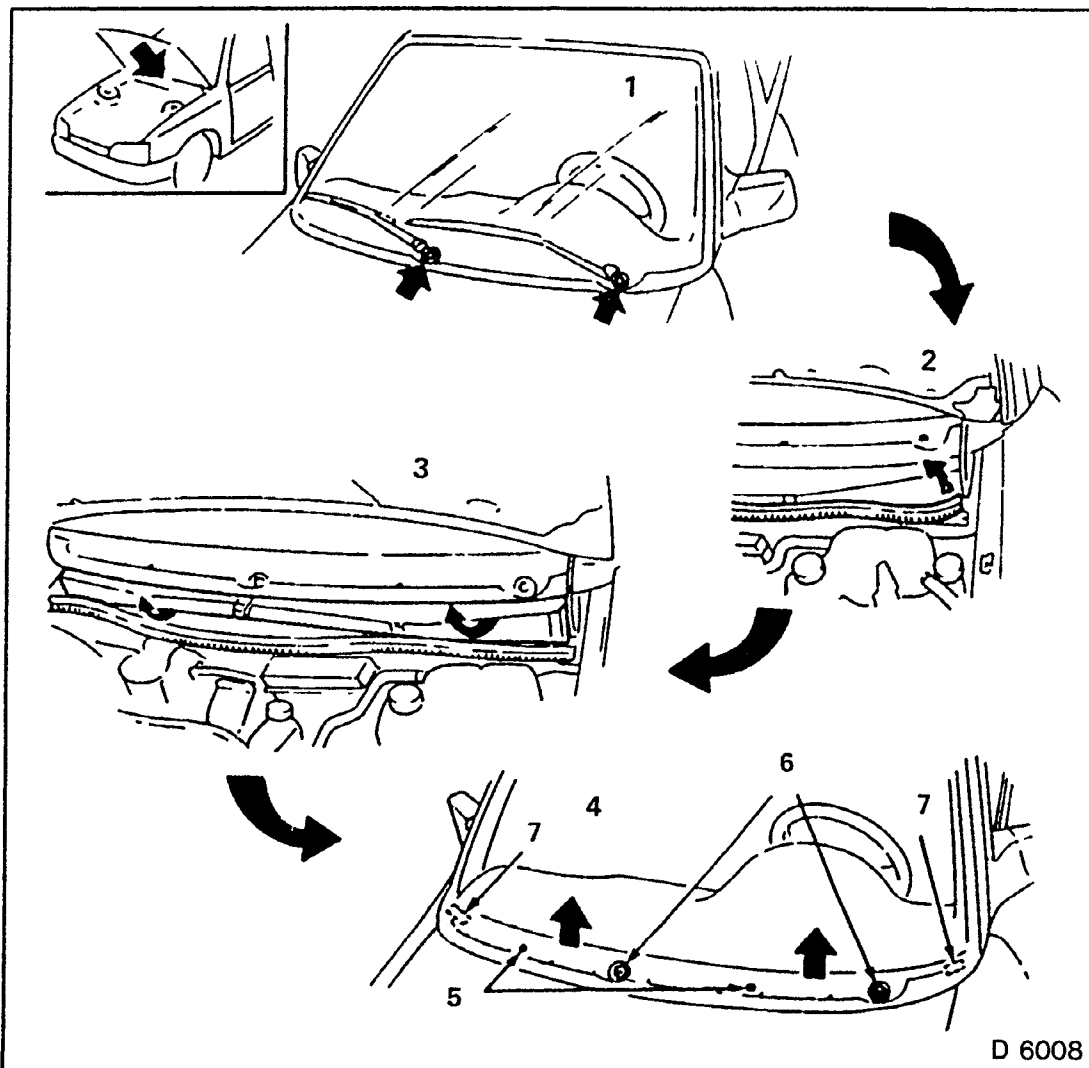


Fig. 18

## Outer B Pillar Panel — Remove and Install

### REMOVE, DISCONNECT

1. Panel — Four clips.

### INSTALL, CONNECT

1. Panel.

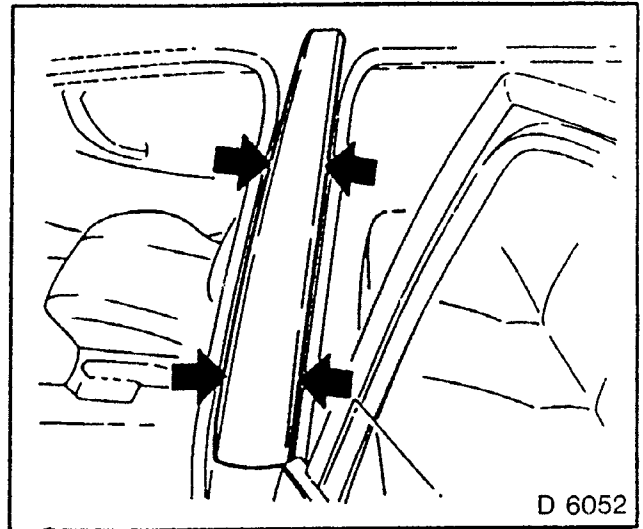


Fig. 20

## Rear Panelling — Remove and Install (Kadett)

### REMOVE, DISCONNECT

1. Licence plate lamp.
2. Rear end panel inner panelling.
3. Rear panelling.
4. On rear end panel — Two nuts.
5. On each wheel well — Two bolts.

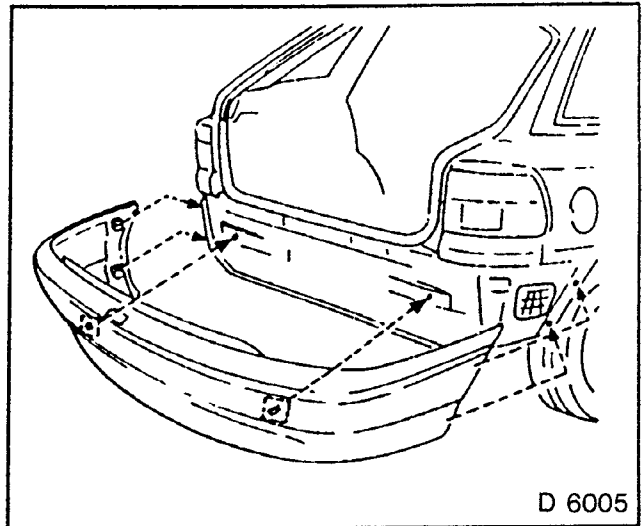


Fig. 21

### INSTALL, CONNECT

(GSi styled bumper only)

1. After painting cement two damping strips 150 mm long to inside of rear panelling.
2. Rear panelling.
3. Inner panelling.
4. Licence plate lamp.

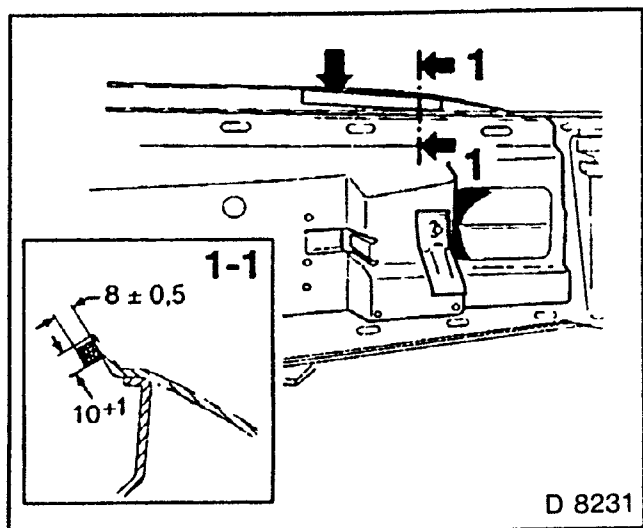


Fig. 22



## Rear Panelling — Remove and Install (Astra)

### REMOVE, DISCONNECT

1. Licence plate lamp.
2. Rear end panel inner panelling.
3. Rear panelling.
4. On rear end panel — Two nuts.
5. From wheel well — Two bolts on each.

### INSTALL, CONNECT

1. Rear panelling.
2. Licence plate lamp.
3. Inner panelling.

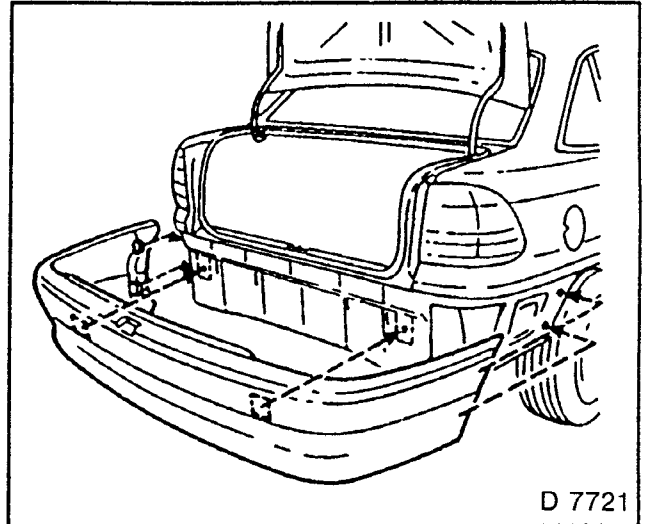


Fig. 23

## Rear Spoiler — Remove and Install (Kadett)

### REMOVE, DISCONNECT

1. Rear spoiler — Four bolts (1).
2. Rear spoiler member — Seven plastic nuts (2).
3. Remove spray nozzle (3).

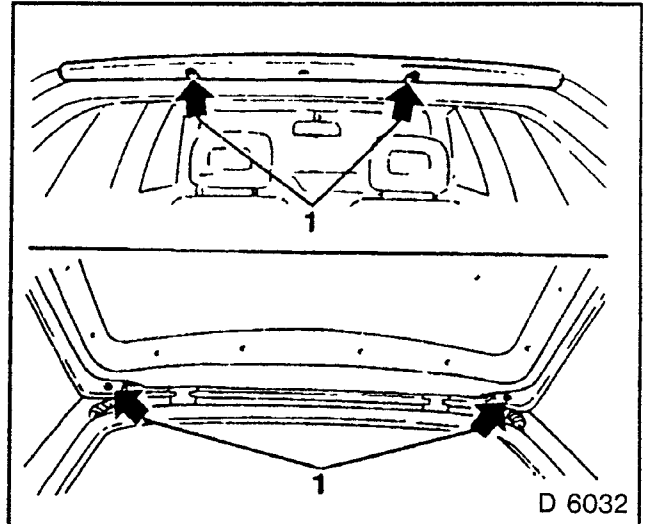


Fig. 24

### INSTALL, CONNECT

1. Rear spoiler member — use new plastic nuts.
2. Spray nozzle.
3. Rear spoiler.

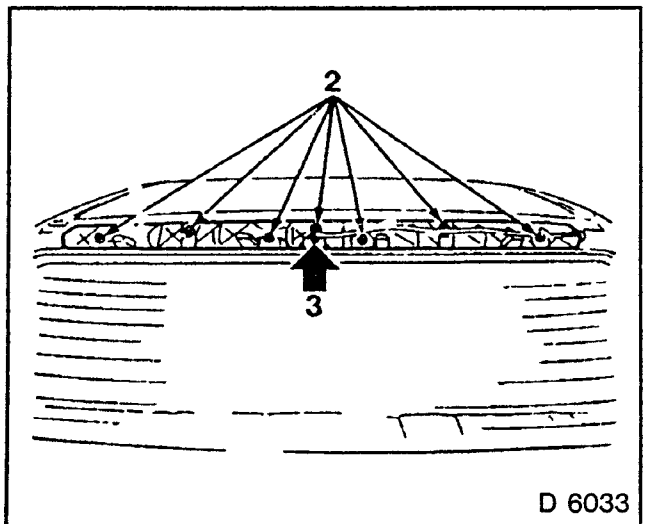


Fig. 25

## Rear Spoiler

### — Remove and Install (Kadett) (200iS & 200ts)

#### REMOVE, DISCONNECT

1. Tailgate upper inner panelling.
2. Rear spoiler.
  - 1.1 = Lever out two covers
  - 1.2 = Two bolts
  - 2 = Eight bolts
  - 3 = Remove double-sided adhesive tape
  - 4 = Remove rear spoiler washer nozzle bracket  
Seven plastic nuts  
Four bolts
- 5 = Remove seals and retaining clip.

#### INSTALL, CONNECT

1. Rear spoiler bracket.
2. Use new plastic nuts and new adhesive tape.
3. Rear spoiler.

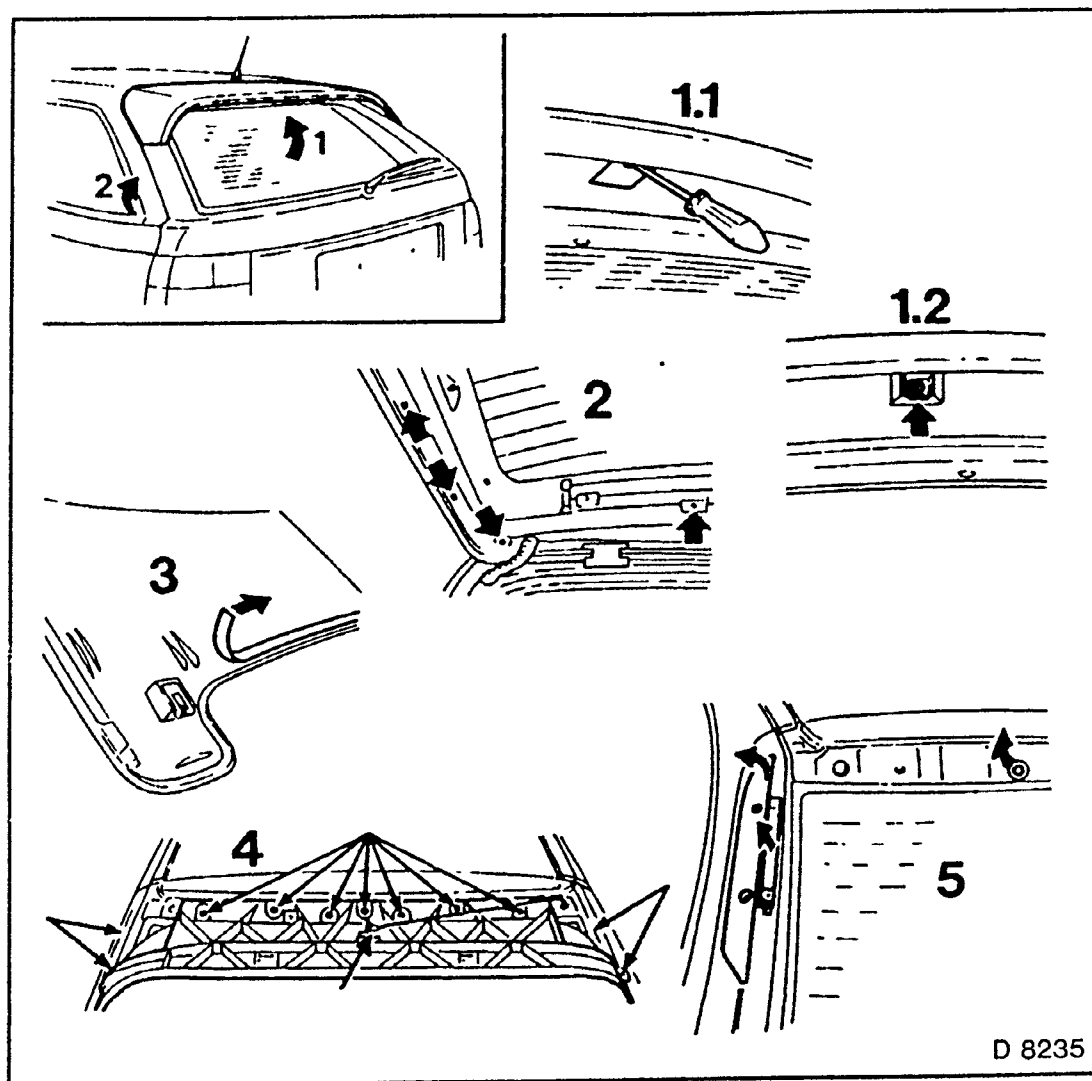


Fig. 26

# Rear Spoiler — Install (Astra)

(Additional operation to replacement of luggage compartment lid)

Only installation of standard rear spoiler is described.

## INSTALL, CONNECT

1. Transfer drill dimensions.
2. Drill holes.
3. Deburr hole edges and protect against corrosion.

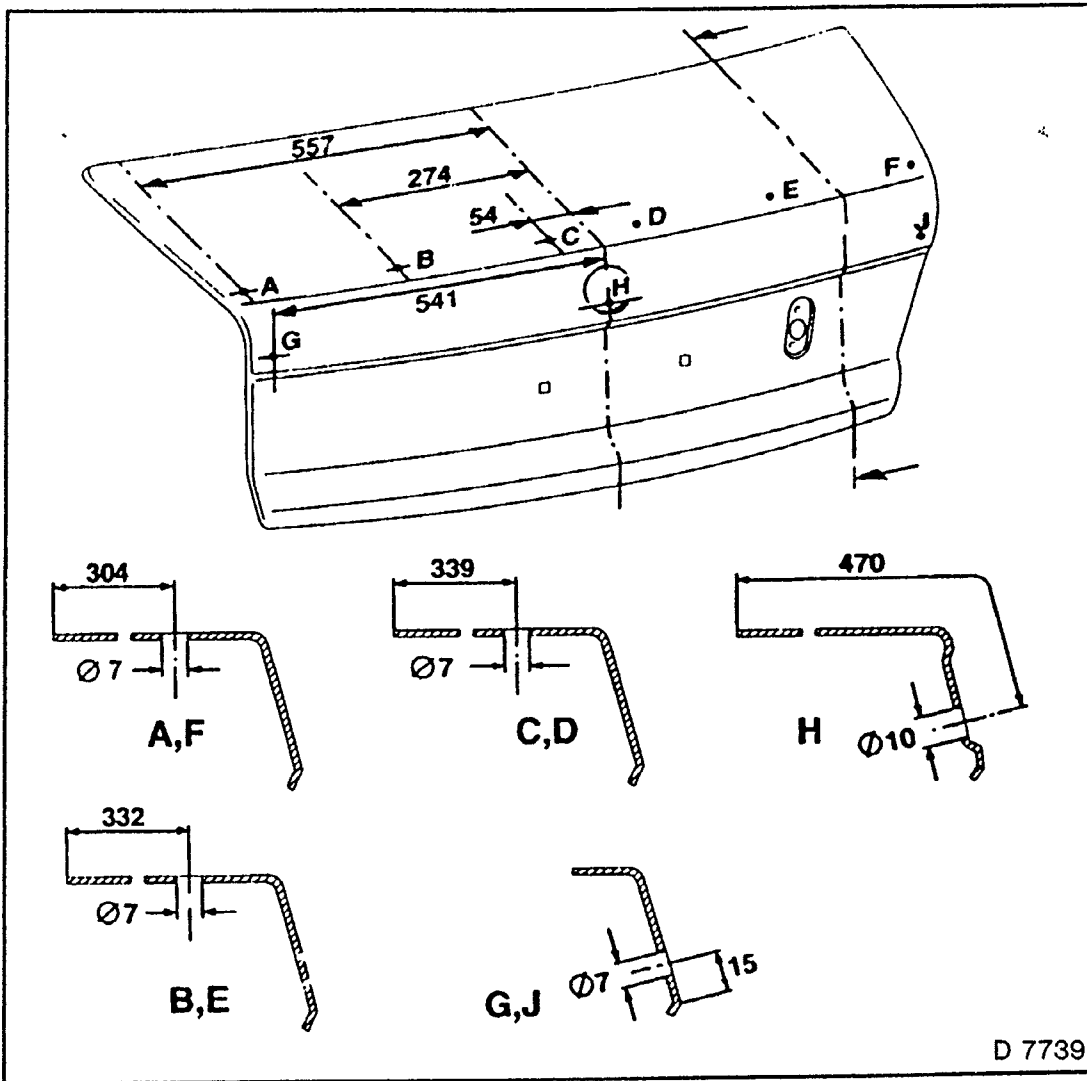


Fig. 27

**INSTALL, CONNECT**

1. Seal holes for company emblem on luggage compartment lid.
2. Clean cement surfaces on rear spoiler and luggage compartment lid.
3. Attach double-sided adhesive tape to rear spoiler (approximately 4 mm from outer edge).
4. Remove protective foil.
5. Place rear spoiler on luggage compartment lid.
6. Fasten rear spoiler.
7. Fastening parts:
  - 1 = Double-sided adhesive tape
  - 2.1 = Special hex bolt
  - 2.2 = Cap, self-adhesive
  - 2.3 = Seal
  - 3.1 = Hex nut with washer
  - 3.2 = Seal
8. Attach company emblem.

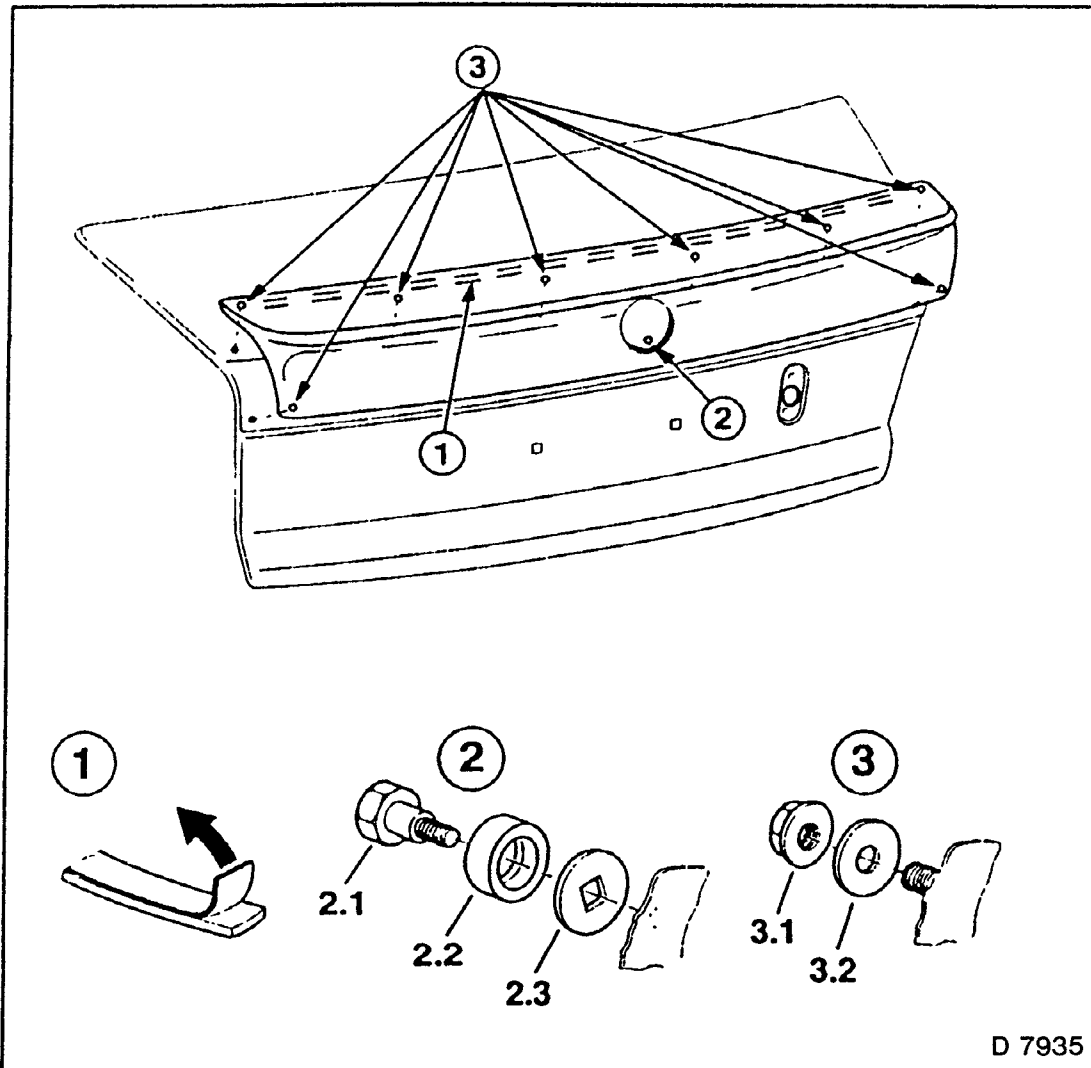


Fig. 28

D 7935

## Tailgate Trim Strip — Remove and Install (Kadett) (200iS & 200ts)

### REMOVE, DISCONNECT

1. Licence plate.
2. Pull trim strip towards rear out of retaining clamps.

### INSTALL, CONNECT

1. Trim strip.
2. Licence plate.

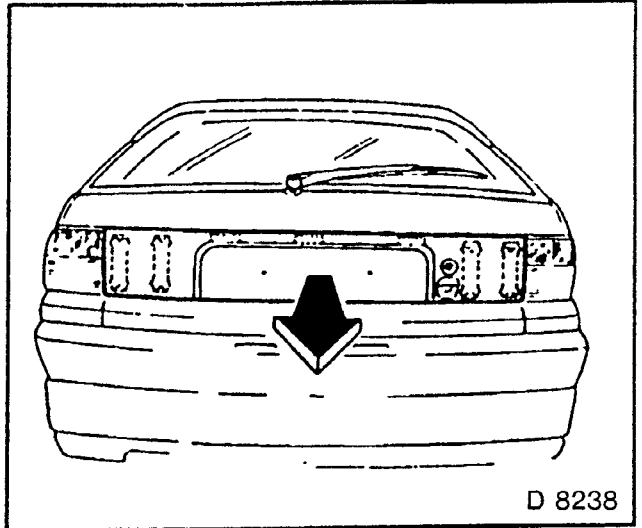


Fig. 29

## SHEET METAL PARTS (BOLTED)

### Wing — Remove and Install

#### REMOVE, DISCONNECT

1. Radiator grille.
2. Front panelling.
3. Turn signal unit.
4. Seven bolts on ridge line.
5. Wheel well inner panelling from wing.

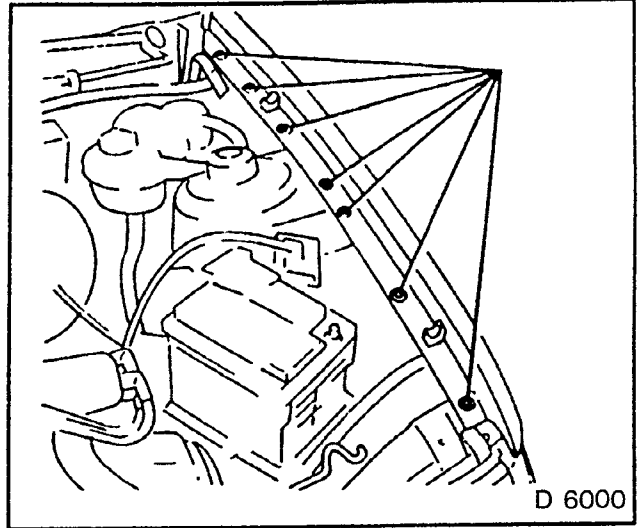


Fig. 30

6. Two bolts on outer A pillar
7. One bolt on wheel well bracket.
8. One bolt on front panel.
9. Wing.
10. Separate sealing compound (thermo-knife).

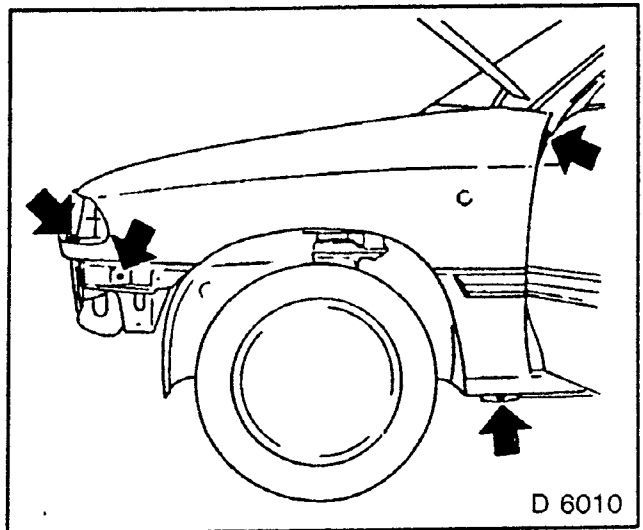


Fig. 31

#### INSTALL, CONNECT

1. Wing.
2. Seal bolt flange with sealing compound.
3. Align wing to neighbouring parts and fasten.

Pos.	Dimension in mm
1	4.5
2	4

1

2

Tolerance  $\pm 1$  mm.

4. Apply protective wax to inside of wing.

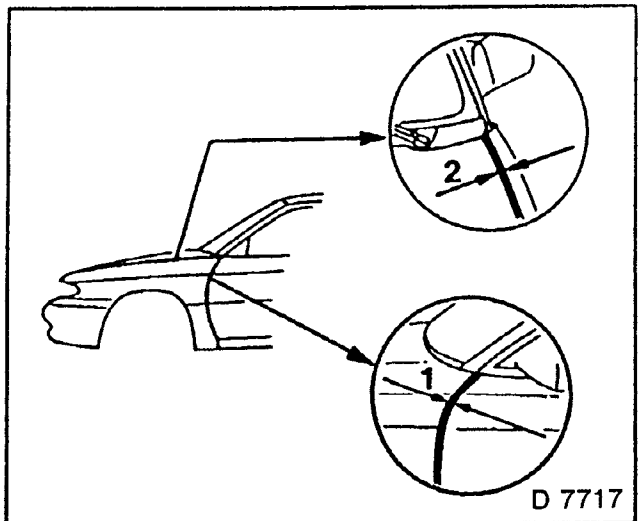


Fig. 32

With optional equipment "sill stone protector"

1. Blind rivets for retaining clips according to drill diagram on wing.
2. Protect drilled holes against corrosion.

**INSTALL, CONNECT**

1. Turn signallamp.
2. Front panelling.
3. Radiator grille.

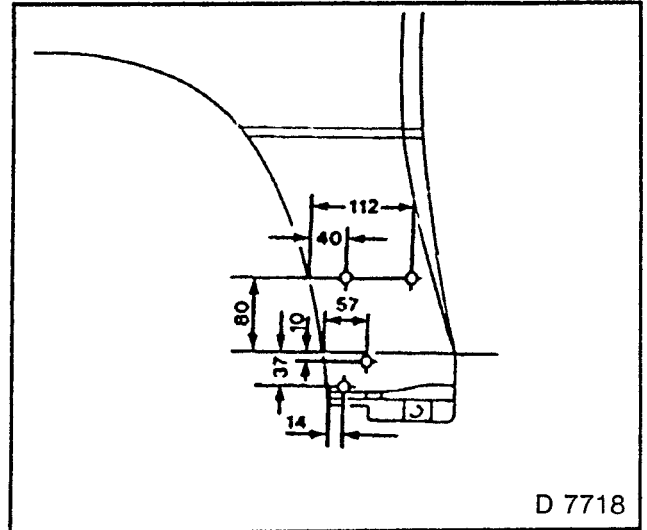


Fig. 33

**Bonnet, Bonnet Functioning Parts — Remove and Install**

**REMOVE, DISCONNECT**

1. Bonnet from both hinge bows (1) — second mechanic.
2. Bonnet attaching parts.

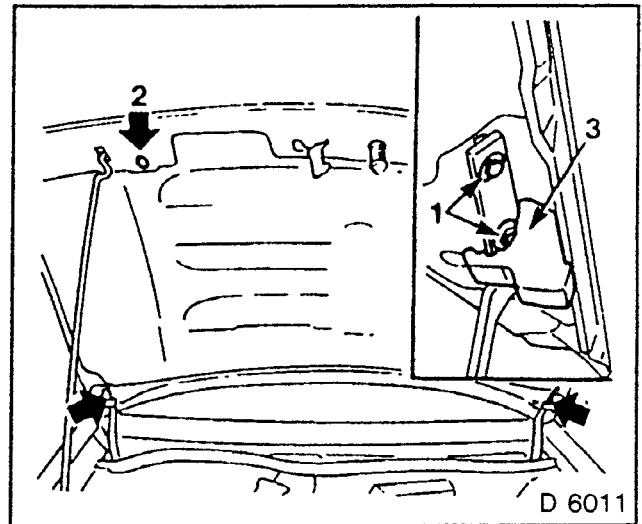


Fig. 34

**INSTALL, CONNECT**

- 1 Bonnet.  
Attaching parts
- 2 Screw in rubber buffer (2) — adjust height.
3. Cement damping rubber (3).

**INSTALL, CONNECT**

Lock components:

1. 3 = Spiral spring
2. 4 = Closure hook
3. 5 = Fastening rivet
4. Expand ends of rivet with pliers (6).

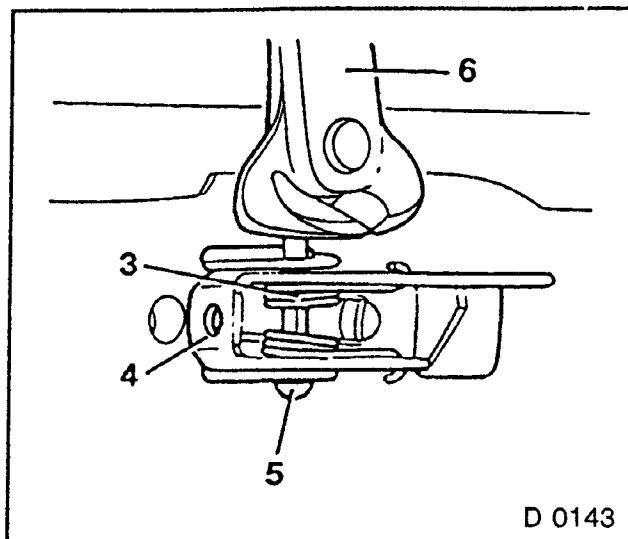


Fig. 35

5. Lock striker pin

**ADJUST**

Adjust dimension X = 40 to 45 mm measured from bonnet panel to washer (9).

Counterhold nut (7).

Order:

- 7 = Disc nut
- 8 = Coil spring
- 9 = Washer
- 10 = Lock striker pin with wrench size.

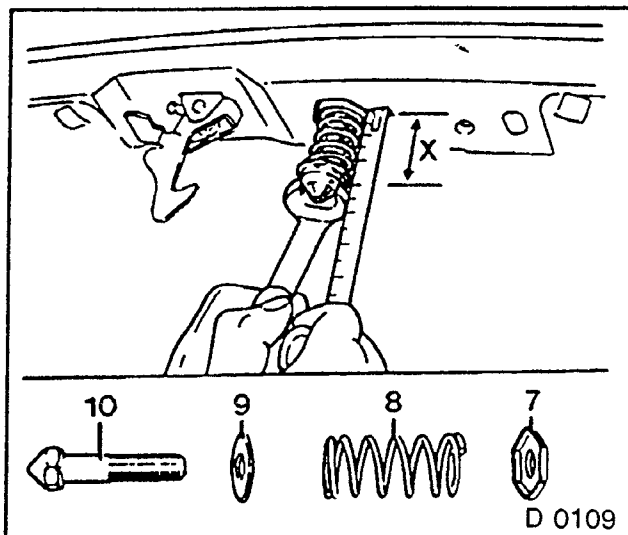


Fig. 36

**Bonnet Hinge — Replace****REMOVE, DISCONNECT**

1. Cowl panel
2. Bonnet.
3. Grind off head of rivet from hinge pin.
4. Remove hinge pin.
5. Hinge bow.

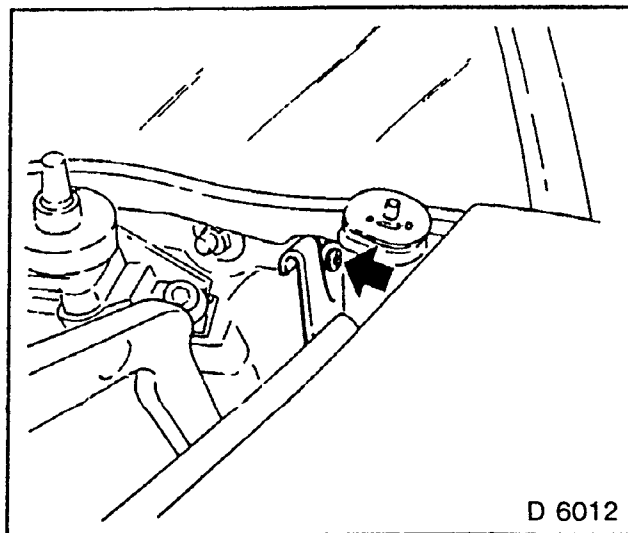


Fig. 37



**INSTALL, CONNECT**

- 1. Collar bolt — install instead of rivet pin.

Order of installation:

- 1 = Collar bolt (vehicle inside)
- 2 = Spring washer
- 3 = Hinge bow
- 4 = Bracket (retainer on body)
- 5 = Washer
- 6 = Hex nut

- 2. Bonnet.
- 3. Cowl panel.

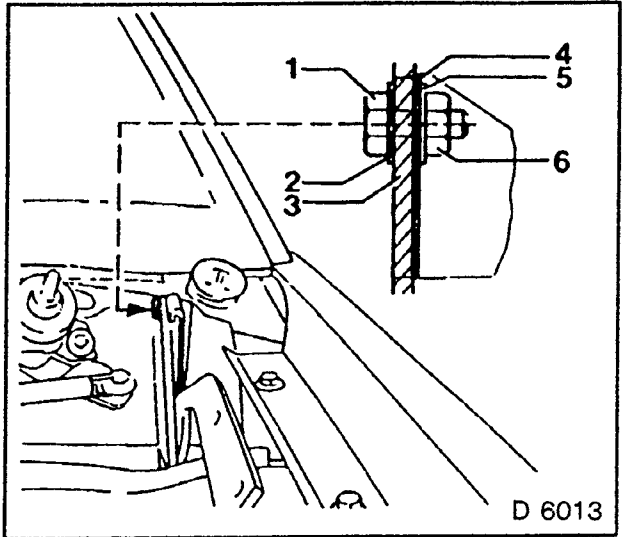


Fig. 38

**Tailgate — Remove and Install**

**REMOVE, DISCONNECT**

- 1. Wiring harness.
- 2. Screen washer nozzle hose.
- 3. Pneumatic spring.
- 4. Remove retaining clamp.
- 5. Tailgate — remove hinge pin.
- 6. Attaching parts.

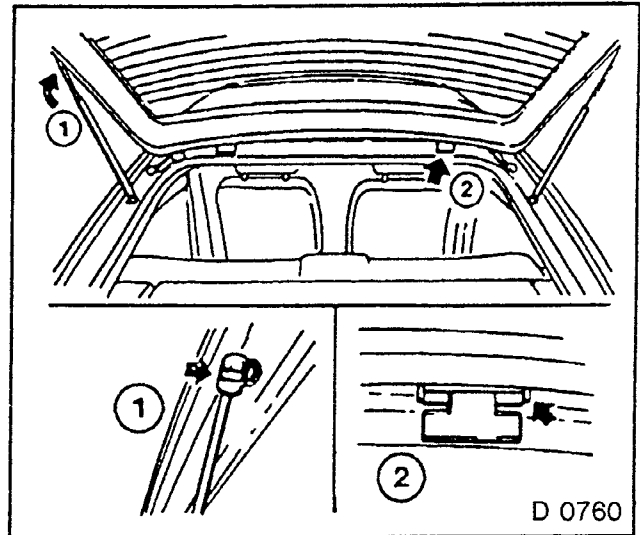


Fig. 39

**INSTALL, CONNECT**

- 1. Tailgate.
- 2. Attaching parts

## Luggage Compartment Lid — Remove and Install (Astra)

### REMOVE, DISCONNECT

1. 1 = Luggage compartment lid from hinge bow — Second mechanic required.
2. Attaching parts.

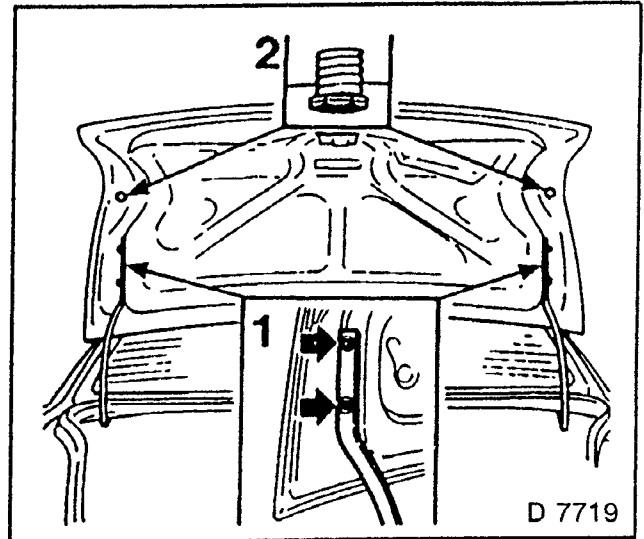


Fig. 40

### INSTALL, CONNECT

1. Luggage compartment lid.
  2. Attaching parts.
- 2 = Screw in rubber buffer — adjust height.

## Hinge Bow, Luggage Compartment Lid — Replace (Astra)

### REMOVE, DISCONNECT

1. Luggage compartment lid.
2. C/D pillar panelling.
3. Open service door (shown without service door).

- 1 = Detach tension spring  
2 = Hinge bow.

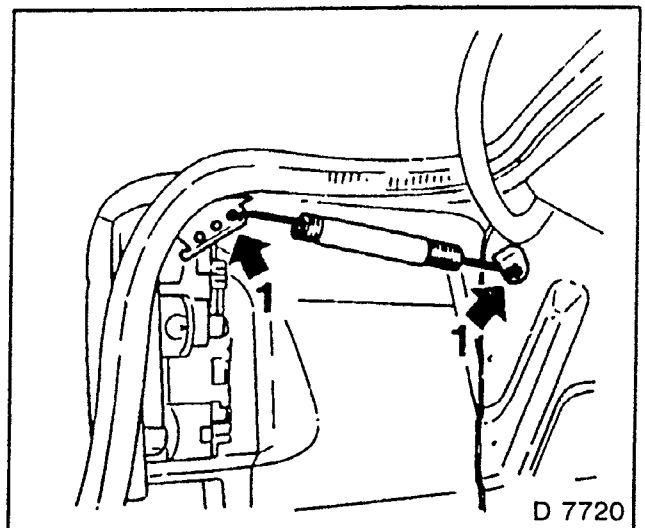


Fig. 41

**INSTALL, CONNECT**

1. Hinge bow.
2. Attach tension spring.
3. Close service door.
4. C/D pillar panelling.
5. Luggage compartment lid.

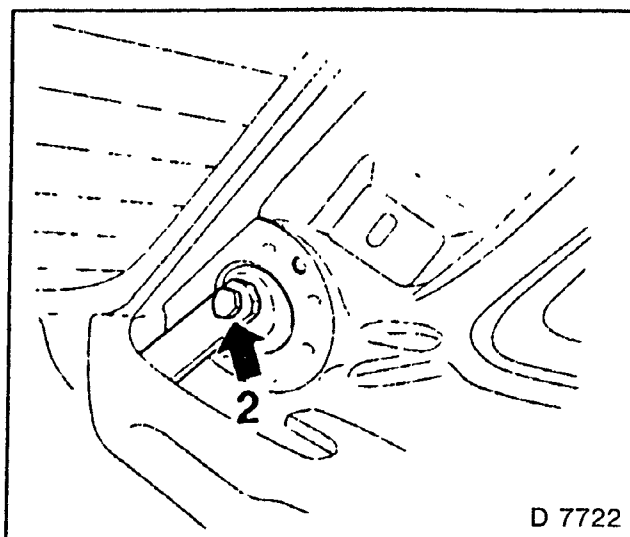


Fig. 42

## SHEET METAL PARTS (WELDED)

### Front Member (Radiator Crossmember) — Replace

#### REMOVE, DISCONNECT

1. Attaching parts.
2. Drill off front member
3. Side member.
4. Lock plate.
5. Front support
6. Gain access to welding spots by separating underside of front member.

#### INSTALL, CONNECT

1. Prepare front member
2. Apply spot welding paint.
3. Fit front member — use body straightening bench.
4. Weld in front member.
5. Attaching parts

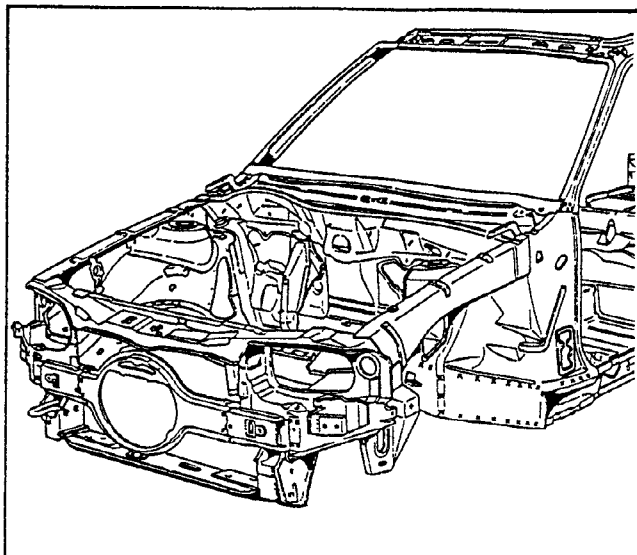


Fig. 43

### Front Member (Radiator Crossmember) — Replace Partially

Special economy parts are designed for partial replacement.

Only the procedures that deviate from the operation "Front Member (Radiator Crossmember), Replace" are described

#### REMOVE, DISCONNECT

1. Separate front member (damaged side) approximately 100 mm to right of centre of vehicle.
2. Note size of new part.  
Separation point applies to both right and left partial replacement.

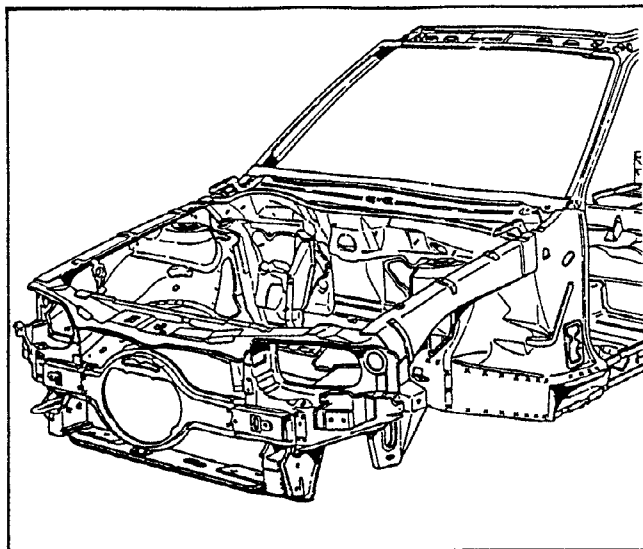


Fig. 44

**INSTALL, CONNECT**

1. Member
2. Butt-weld at cut point.

**Front Member Centre  
— Replace****REMOVE, DISCONNECT**

1. Attaching parts.
2. Drill off front member.

**INSTALL, CONNECT**

1. Prepare front member.
2. Apply spot welding paint.
3. Fit front member.
4. Weld in front member.
5. Attaching parts

**Air Deflector Panel  
Assembly  
— Replace Completely****REMOVE, DISCONNECT**

1. Attaching parts.
2. Drill off air deflector panel assembly.
3. Wheel well.
4. Side member.
5. Front Support.

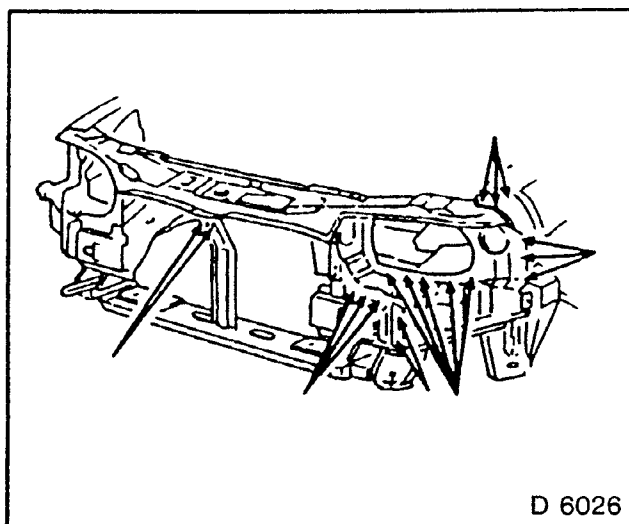


Fig. 45

**INSTALL, CONNECT**

- 1 Prepare air deflector panel
- 2 Apply spot welding paint.
- 3 Fit air deflector panel.
- 4 Weld in air deflector panel.
- 5 Attaching parts.

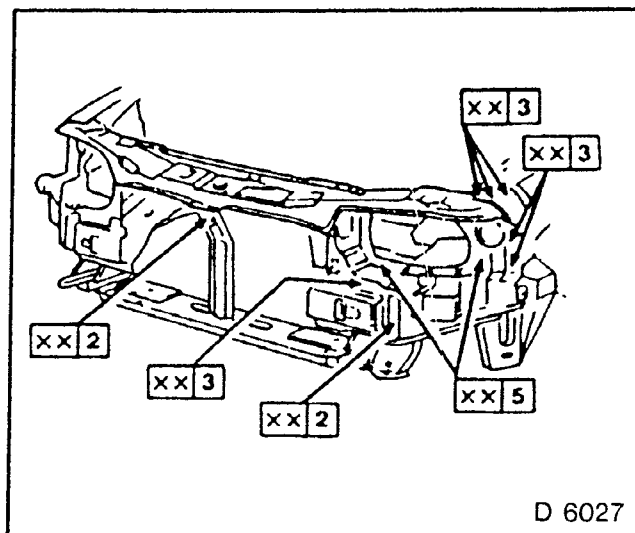


Fig. 46

## Air Deflector Panel Assembly — Replace Partially

Special economy parts are designed for partial replacement.

Only the procedures that deviate from the operation "Air Deflector Panel Assembly, Replace Completely" are described.

**REMOVE, DISCONNECT**

1. Separate air deflector panel (damaged side) approximately 100 mm to right of middle of vehicle.
2. Note size of new part.  
Separation point applies to both right and left partial replacement.

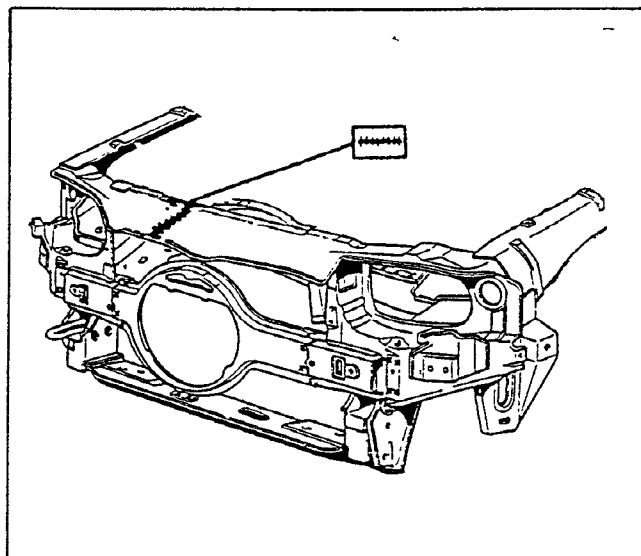


Fig. 47

**INSTALL, CONNECT**

1. Butt-weld air deflector panel to cut point.

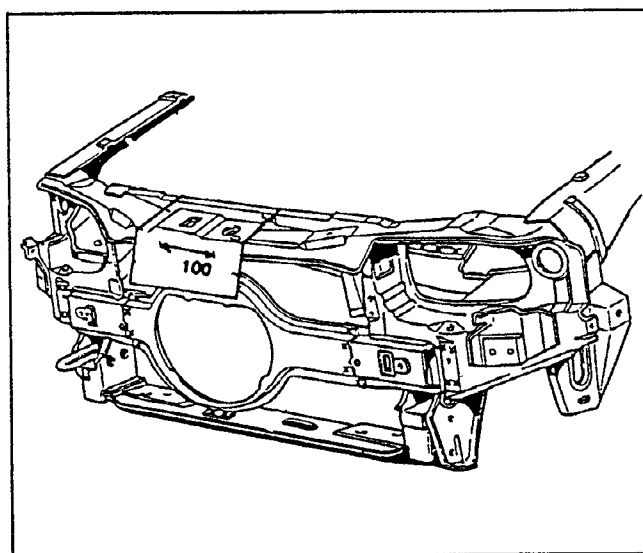


Fig. 48

## Side Bracket for Front Panelling — Replace

### REMOVE, DISCONNECT

1. Attaching parts
2. Mark contact surface (1).
3. Drill off bracket.
4. Air deflector panel.
5. Wheel well.

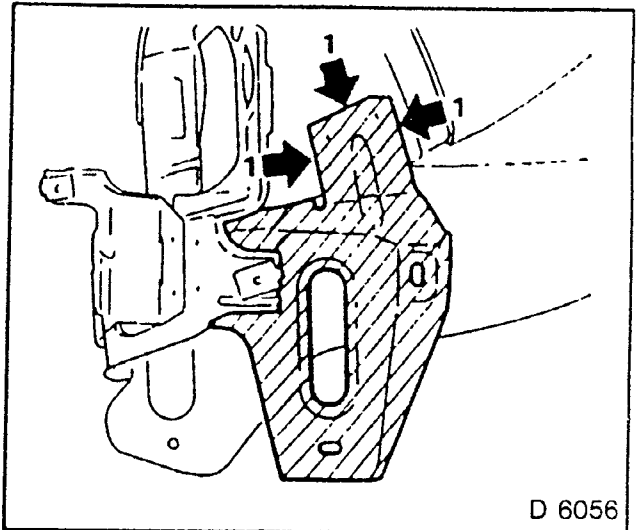


Fig. 49

### INSTALL, CONNECT

1. Prepare bracket.
2. Apply spot welding paint.
3. Weld in bracket as in production.  
Distance from front panelling front fastening to centre of hole: 200 mm
4. Attaching parts.

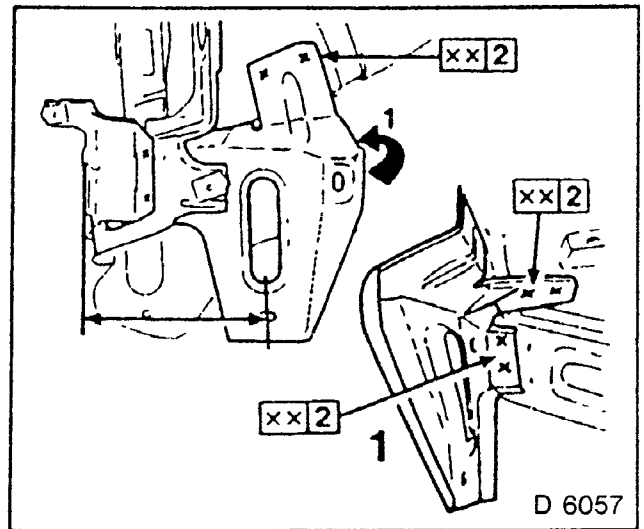


Fig. 50

## Front Wheel Well — Replace Completely

(Additional operation to replacement of air deflector panel).

### REMOVE, DISCONNECT

1. Attaching parts.
2. Wheel well strut.
3. Drill off wheel well sheet metal.
4. Side member.
5. Bulkhead.

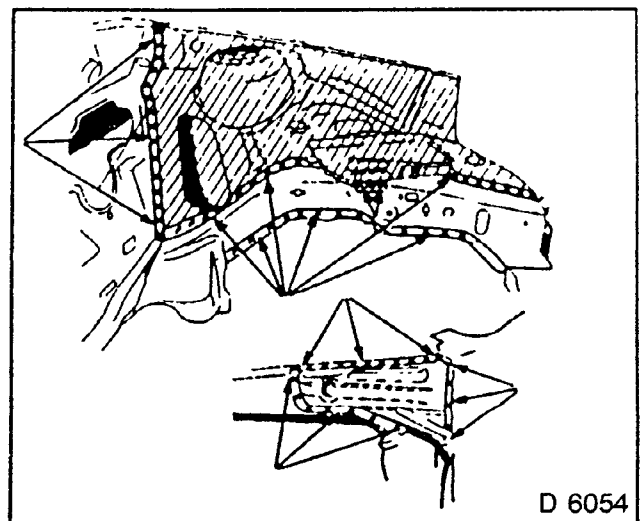


Fig. 51

**INSTALL, CONNECT**

1. Fit wheel well sheet metal — use body straightening bench.
2. Prepare flanges.
3. Apply spot welding paint or spot welding tape.
4. Weld in new part.
5. Weld wheel well strut.
6. Seal body seams.
7. Seal cavities.
8. Apply corrosion protection
9. Attaching parts.

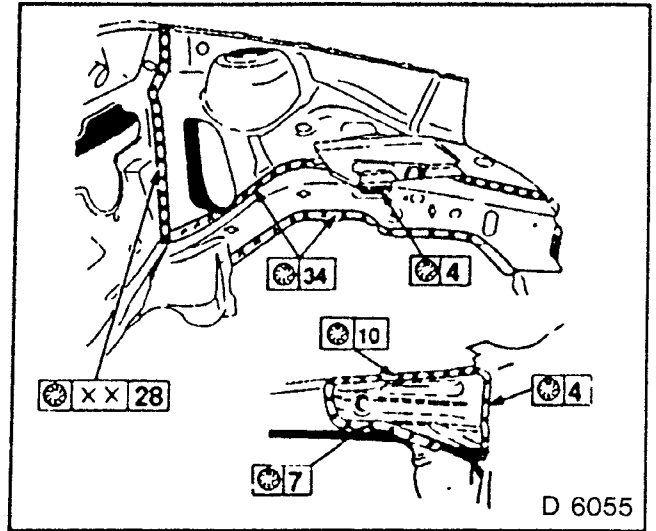


Fig. 52

**Wheel Well and Front Frame Side Member — Replace Partially**

Special economy parts are available for partial replacement (part without dome cap, without battery carrier).

Only operations that deviate from operation "Wheel Well Front, Replace Completely" are described.

**REMOVE, DISCONNECT**

1. Wheel well panel (1).
2. Separate in front of dome cap. **DO NOT** damage dome cap flange.
3. Separate side member (2) according to given measurements.

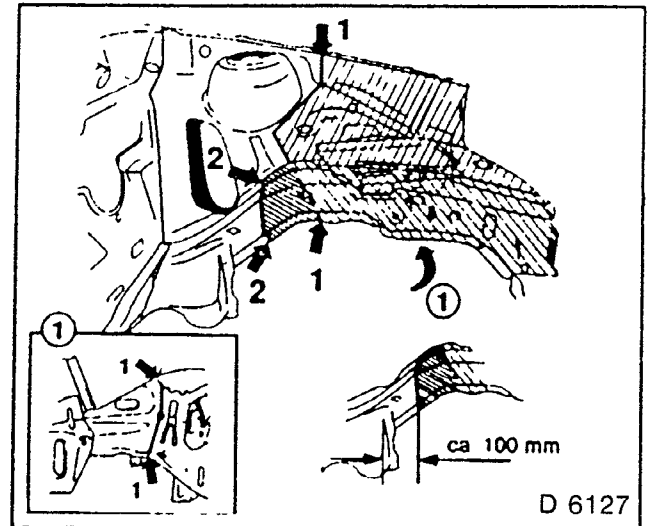


Fig. 53

**INSTALL, CONNECT**

1. Fit new parts — use body straightening bench.
2. Prepare flange.
3. Apply spot welding paint or spot welding tape.
4. Side member.
5. Wheel well panel.
6. Butt weld at cutting point.
7. Plug spot weld at overlapping points.

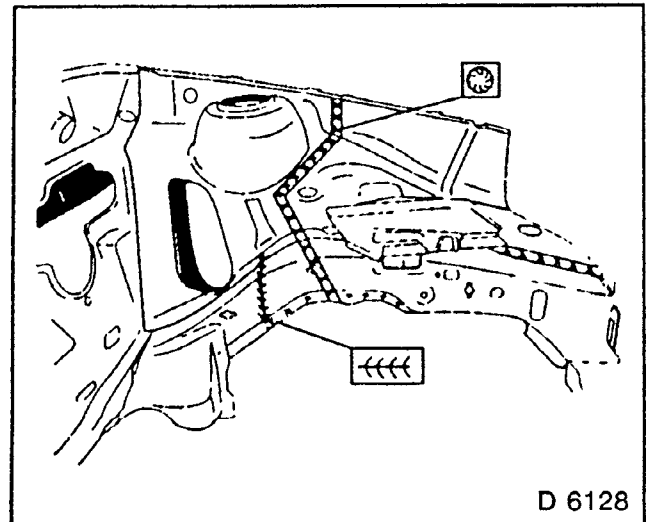


Fig. 54



## Control Arm Brace — Front Frame Side Member — Replace

### REMOVE, DISCONNECT

1. Attaching parts.
2. Drill off control arm brace and separate in front of crossmember floor.

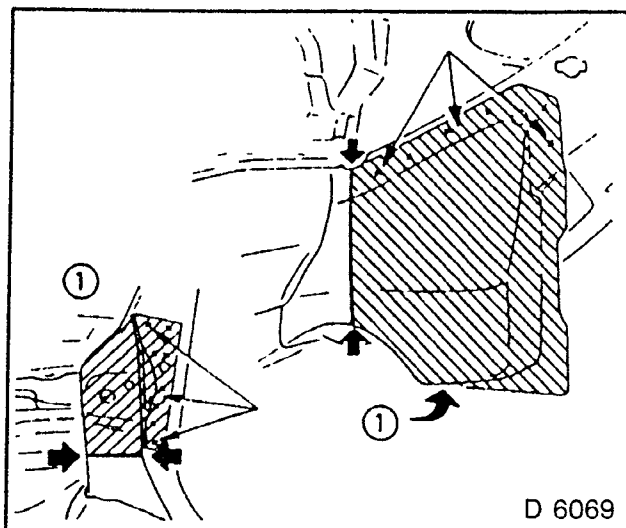


Fig. 55

### INSTALL, CONNECT

- 1 Prepare control arm brace.
2. Apply spot welding paint.
3. Fit control arm brace — use body straightening bench.
- 4 Weld in control arm brace.
- 5 Seal cavities.
6. Apply corrosion protection.
7. Attaching parts.

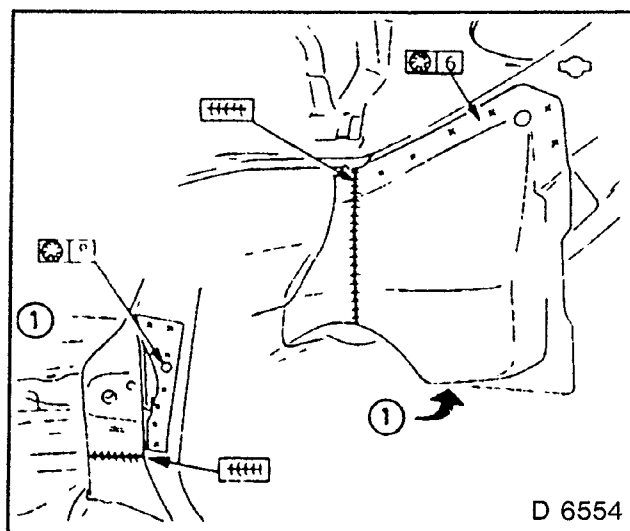


Fig. 56

## A Pillar — Replace

### REMOVE, DISCONNECT

1. Attaching parts.
2. Drill off wheel housing brace.
3. Separate A pillar — cut section 1.  
Note size of new part.  
On partial replacement of A pillar  
(separation at belt line) — cut section 2.

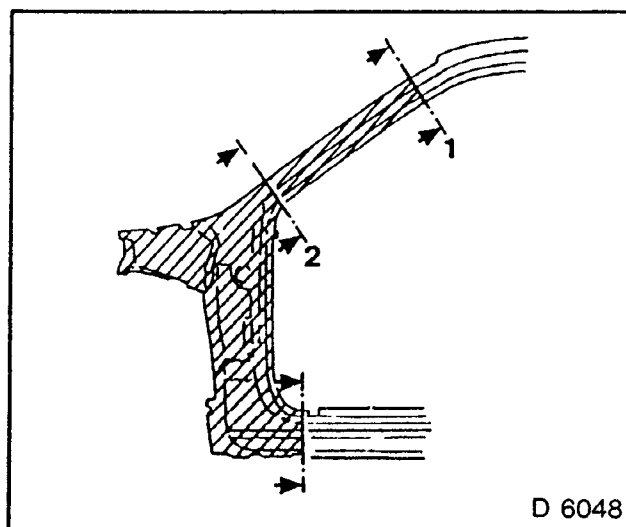
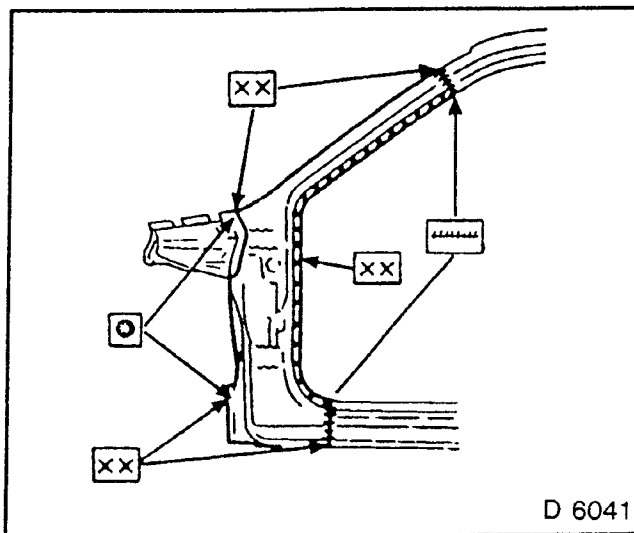


Fig. 57

**INSTALL, CONNECT**

1. Fit A pillar.
2. Prepare flange.
3. Apply spot welding paint or spot welding tape.
4. Weld in A pillar.
5. Weld in wheel housing brace.



D 6041

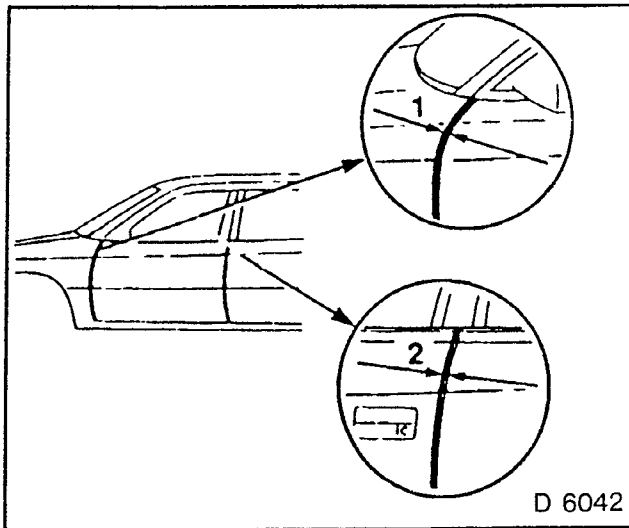
Fig. 58

**NOTE:**

A pillar is supplied with tack welded door hinges.  
 Place front door on hinges and adjust door gap according to measurements.  
 Dimensions vary from door shell to complete door  
 Door shell without door seal makes contact at inside.

Position	Door Shell	Complete door
1	4	4.5
2	5	5.5

All dimensions in mm.  
 Tolerance  $\pm 1$  mm.

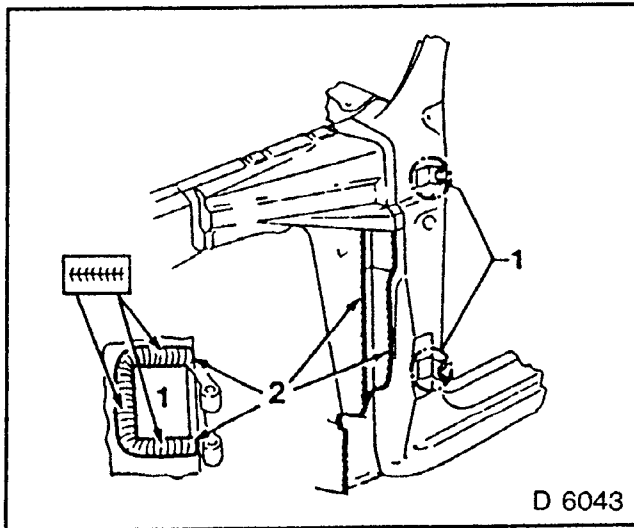


D 6042

Fig. 59

**INSTALL, CONNECT**

1. Weld in hinges (1).
2. Seal welding seam (2).
3. Seal cavities.
4. Attaching parts.



D 6043

Fig. 60

# B Pillar — Replace

## REMOVE, DISCONNECT

1. Attaching parts.
2. Front and rear door.
3. Seats.
4. Separate B pillar from seat belt attachment
5. Note size of new part.

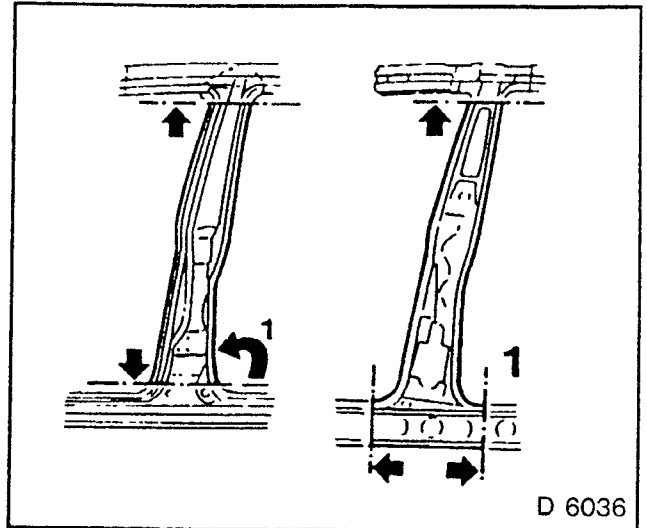


Fig. 61

## INSTALL, CONNECT

1. Fit B pillar.
2. Prepare flange.
3. Apply spot welding paint or spot welding tape.
4. Weld in new part

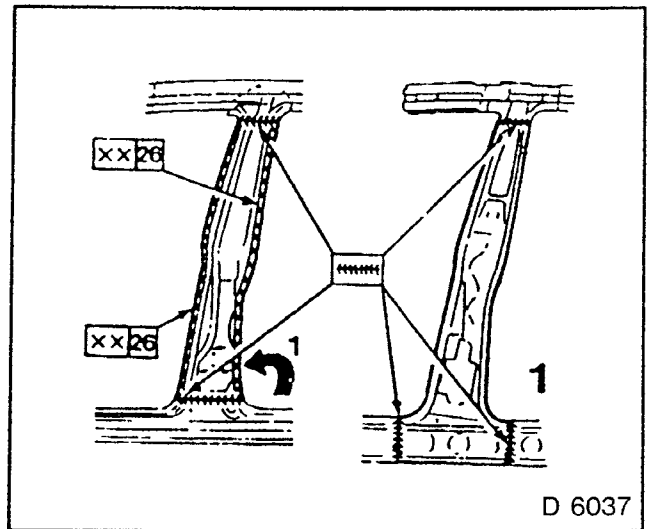


Fig. 62

### NOTE:

B pillar is supplied with tack welded door hinges.

Place rear doors on hinges and adjust door gap according to measurements.

Dimensions vary from door shell to complete door.

Door shell without door seal makes contact at inside.

Position	Door shell	Complete door
1	5	5.5
2	4	4.5

All dimensions in mm.

Tolerance  $\pm 1$  mm.

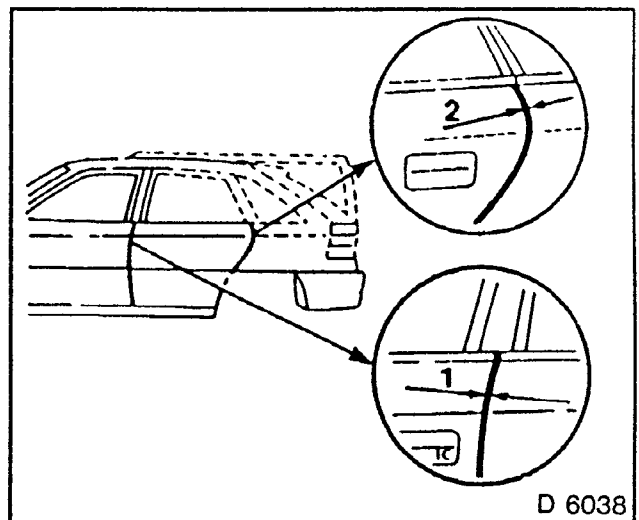


Fig. 63

**INSTALL, CONNECT**

1. Weld in hinges.
2. Seal welding seams.
3. Seal cavities.
4. Attaching parts.

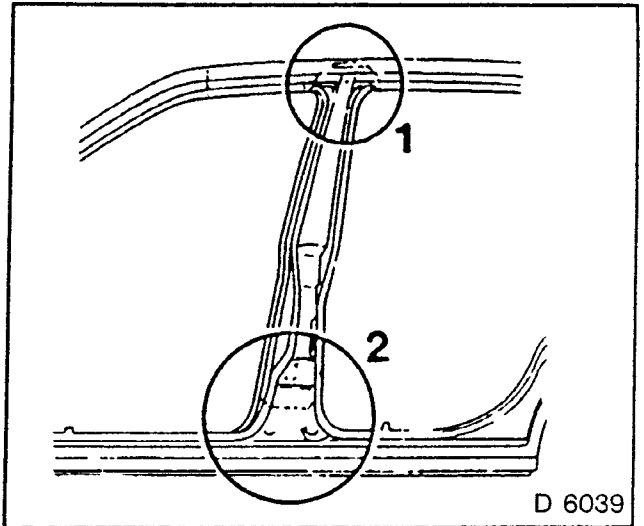


Fig. 64

**Door Sill Panelling, Replace****REMOVE, DISCONNECT**

1. Attaching parts.
  2. Separate door sill panelling.  
**DO NOT** damage reinforcement of A and B pillar.
  3. Note size of new parts.
  4. Fig. 65 shows separation line.
- 1 = Complete replacement.  
2 = Partial replacement, front  
3 = Partial replacement, rear

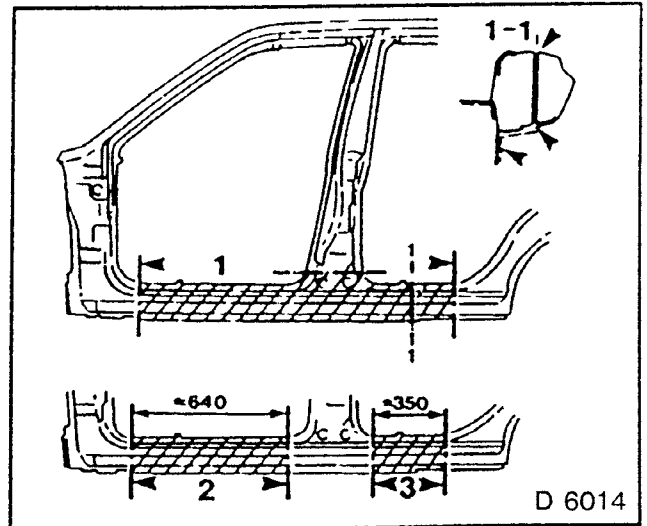


Fig. 65

**INSTALL, CONNECT**

1. Prepare door sill panelling.
2. Apply spot welding paint or spot welding tape.
3. Fit door sill panelling.
4. Weld in door sill panelling.
5. Seal cavities.
6. Coat with underbody protective coating underneath door sill panelling.
7. Attaching parts.

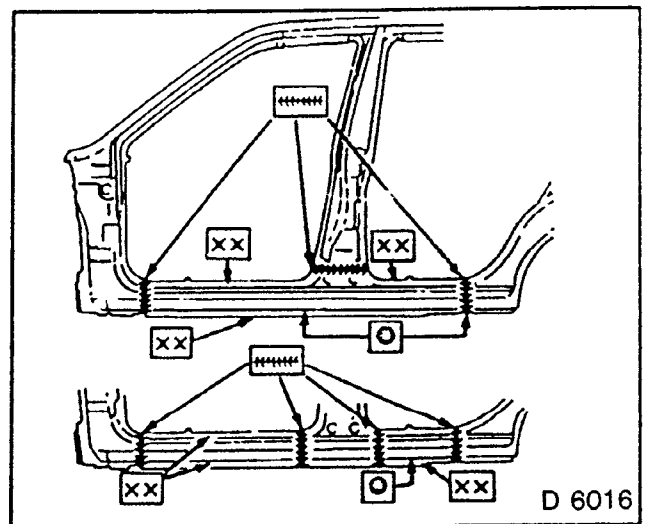


Fig. 66

# Outer Panelling, Door — Replace Outer Panelling, Tailgate — Replace

## REMOVE, DISCONNECT

1. Door/tailgate.

2. Attaching parts.

With new parts with window frame, cut off short — see information on separation points on page 43.

3. Drill off spot welds.

4. Sand down around flanges 1.

5. Remove outer panelling 2 from frame.

6. Remove remaining flange.

7. Remove cement residue 3 from frame.

8 Grind cement flange.

9 Grind cement flange 4 of new part in similar manner.

10. If necessary, align frame.

11 Fit new part to frame and cut points.

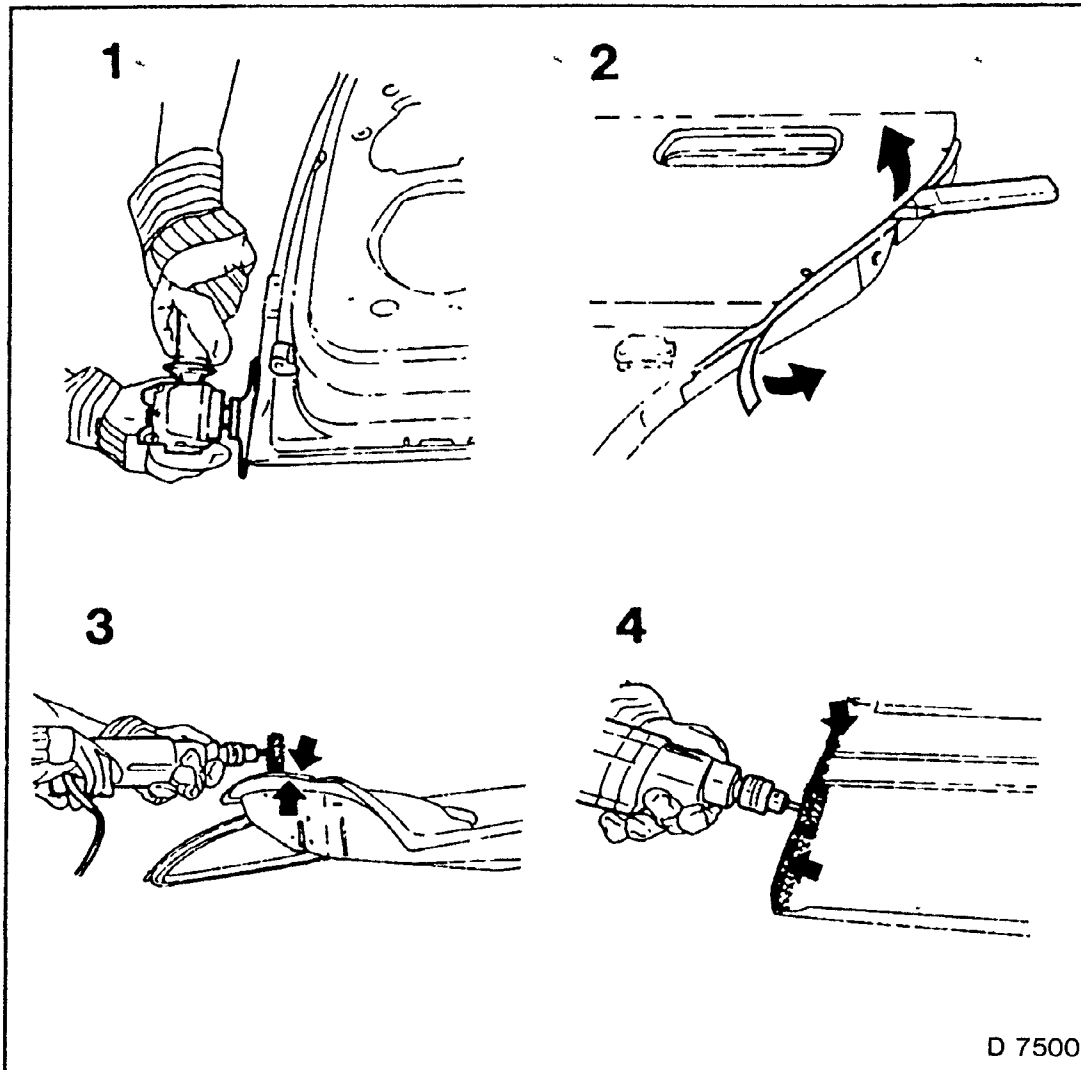
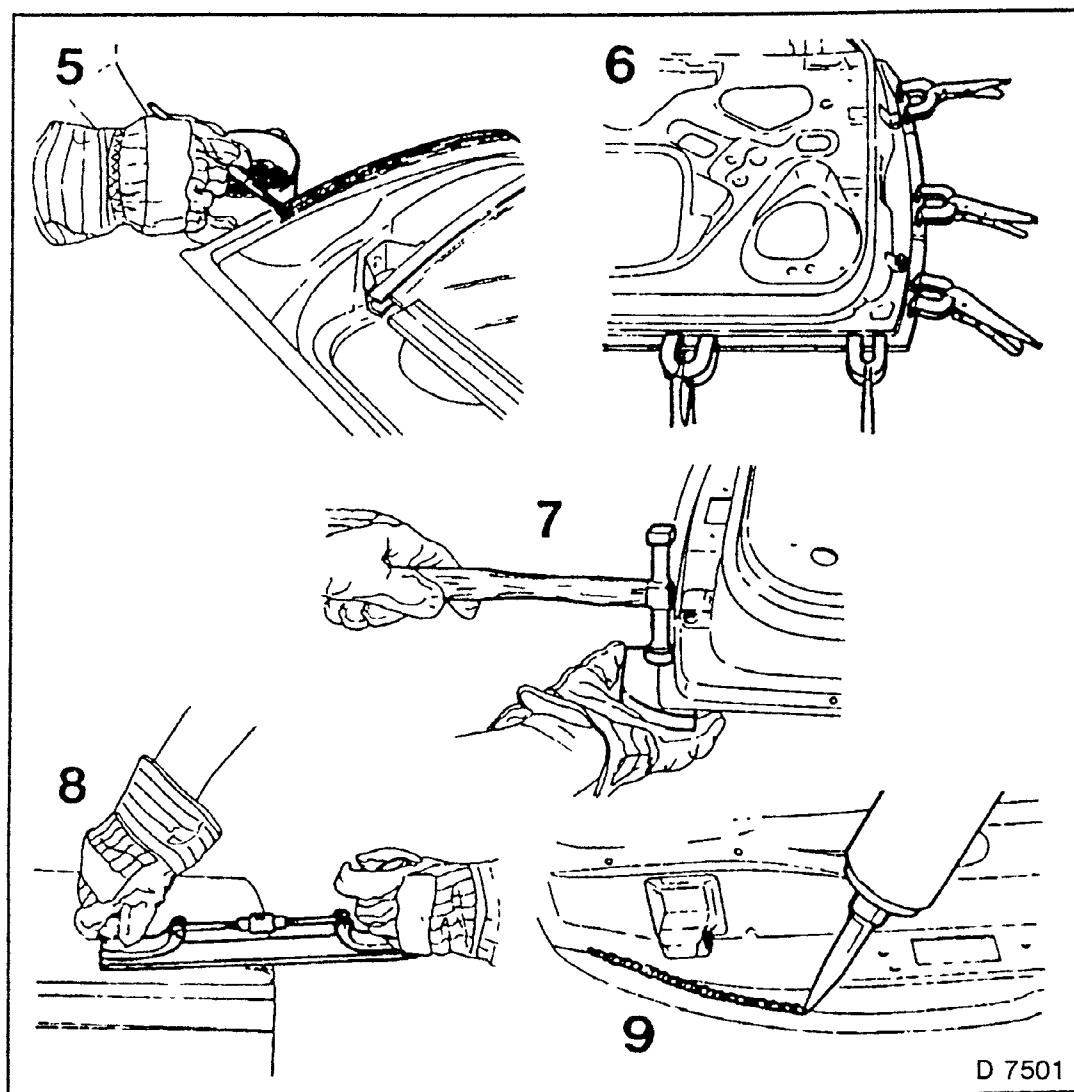


Fig. 67

**INSTALL, CONNECT**

1. Clean all cementing surfaces.
2. Prepare TWO COMPONENT CEMENT (REPAIR PACKAGE) FOR CEMENTING OF BODY SHEET METAL. (See operating instructions).
3. Apply TWO COMPONENT CEMENT 5 to cement flange of frame.
4. Apply TWO COMPONENT CEMENT at least 1 mm thick.
5. Place outer panelling 6 on frame, align and fix in place.
6. Border flange 7 of outer panelling (body hammer and finish hammer). Counterhold at same time with dolly
7. Remove superfluous spilt TWO COMPONENT CEMENT with scraper.
8. Weld outer panelling. Check surface of outer panelling in visible area 8 and — if necessary — rework.
9. Apply SEALING COMPOUND 9 (can be top-coated). It can be applied directly to the remaining "wet" cement.
10. Seal cavities.
11. Attaching parts. Door/tailgate.



D 7501

Fig. 68

**SEPARATION POINTS, WELDING INFORMATION, ATTACHING PARTS TO BE REMOVED.**

1 2 — Rear door (Astra/Kadett).

1. Remove door inner panelling.
2. Outside handle.
3. Outside mirror.
4. Window channel rubber. Outer weatherstrip
5. If present, remove stone protector.

2 —Rear door (Astra/Kadett).

1. Remove door inner panelling.
2. Outside handle.
- 3 Window channel rubber outer weatherstrip.
- 4 Remove insert corners. (Astra/Kadett)

3 — Tailgate (Kadett).

- 1 Remove tailgate screen.
- 2 Inner panelling.
- 3 Outside handle with lock cylinder casing.
- 4 Lock
5. Licence plate.
- 6 Lettering
- 7 Wiper arm.
- 8 If present, remove outer cover

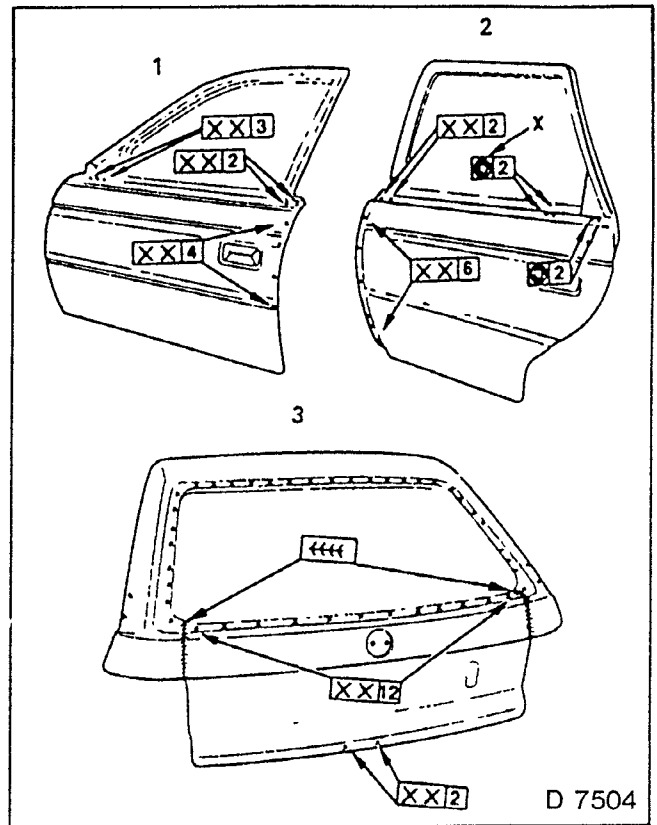


Fig 69

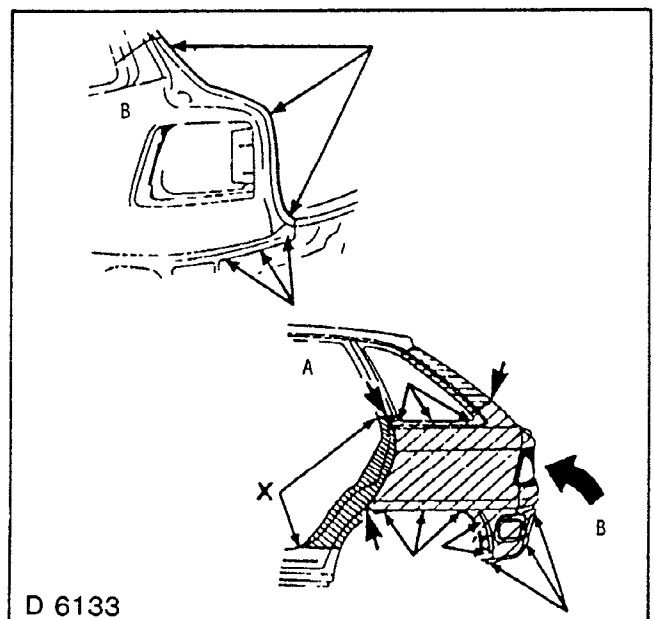
**Rear Quarter Panel — Replace (Kadett)**

**REMOVE, DISCONNECT**

- 1 Attaching parts
  2. Separate quarter panel.
- A = Separation lines. (Kadett).

Note size of new parts

X = Separation door lines on additional operation "Door Sill Panelling, Replace"  
New part of quarter panel is supplied to approximately separation line "X".



D 6133

Fig. 70

**INSTALL, CONNECT**

1. A = Prepare quarter panel.  
Allow flange to overlap, 10 mm wide.  
Fig. 71 shows Kadett.
2. Prepare flange.  
Apply spot welding paint or spot welding tape.
3. Weld in new parts.
4. Seal body seams.
5. Seal cavities.
6. Apply corrosion protection.
7. Attaching parts.

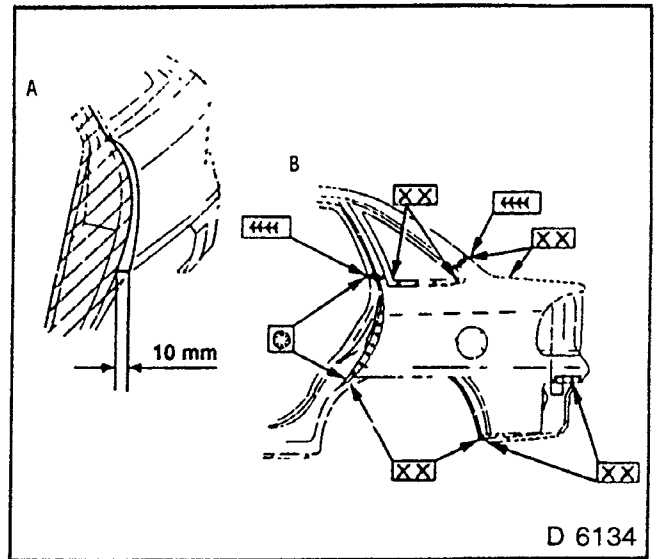


Fig. 71

**Rear Quarter Panel, Replace (Astra)****REMOVE, DISCONNECT**

- 1 Attaching parts.
- 2 Disconnect rear quarter panel  
A = Separation points (Astra).
3. Note size of new parts  
X = Separation lines on additional operation "Door Sill Panelling, Replace"  
New part of quarter panel is supplied to approximately separation line "X".  
D = Drill through welding points connecting body rear quarter panel and roof panel and remove remaining sheet metal.  
E = Optionally separate at upper edge and subsequently cement remainder of flange.

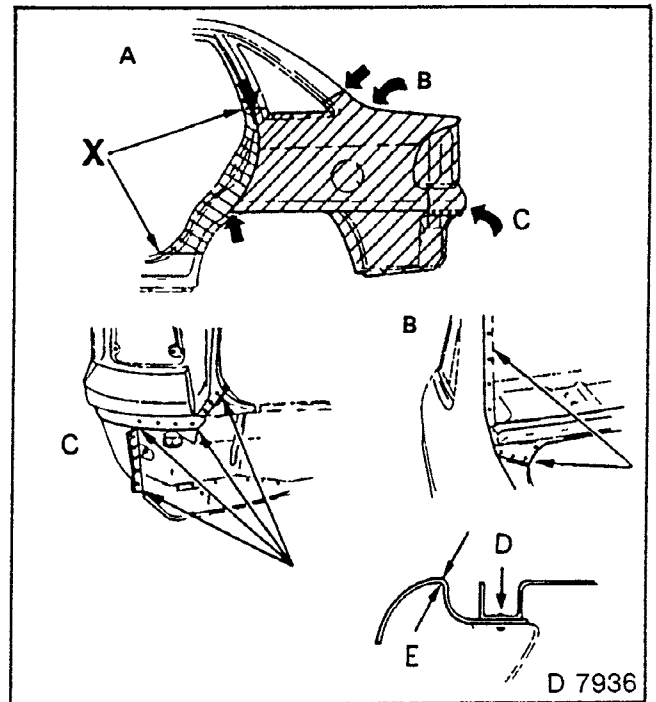


Fig. 72



**INSTALL, CONNECT**

1. Prepare rear quarter panel (Astra).  
Allow flange to overlap by 10 mm.
2. Prepare flange.
3. Apply spot weld paint or spot weld tape.
4. Weld in new part (Astra).

Optionally, cut off new part shortened at upper flange and cement to remainder of flange at upper rear quarter panel with two component cement (repair package) — cementing of body sheet metal

Always observe instructions for use.

5. Seal body seams
6. Seal cavities
7. Apply underseal.
8. Attaching parts.

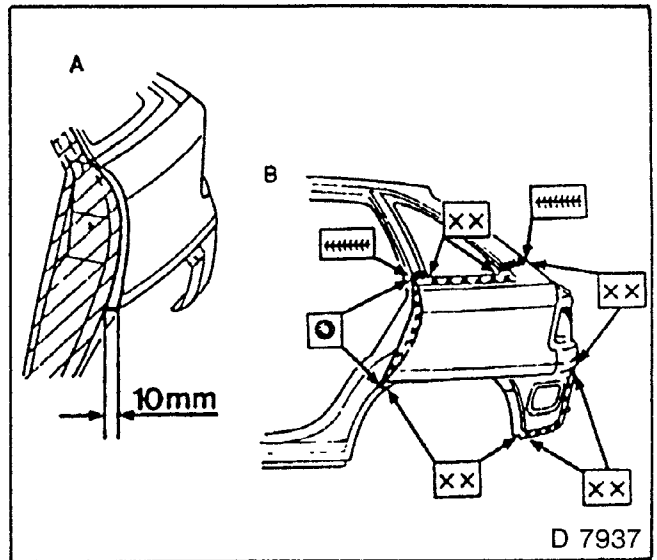


Fig. 73

**Rear Quarter Panel — Replace Partially (Astra)**

**REMOVE, DISCONNECT**

1. Attaching parts.
2. Separate quarter panel  
A = Partial replacement, rear (Astra)  
(bolted rear quarter window, cemented rear screen are not removed).
3. Note size of new part.

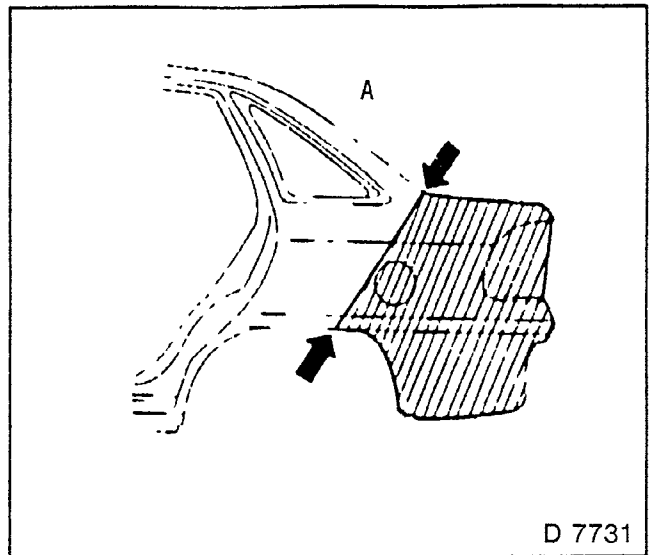


Fig. 74

**INSTALL, CONNECT**

1. Fit rear quarter panel economy part approximately 10 mm allowance for overlap.
2. Crimp flange.
3. Weld in rear quarter panel economy part.
4. Plug weld at overlap point

A = Installation on Astra, rear

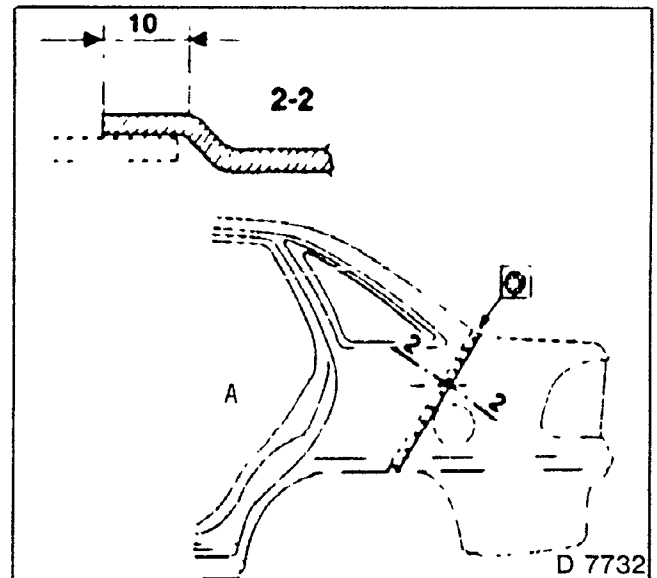


Fig. 75

## Rear Section of Inner Rear Quarter Panel — Replace Partially (Kadett)

(Additional operation to replacement of outer quarter panel).

Special economy parts are available for partial replacement

### REMOVE, DISCONNECT

- 1 Attaching parts.
- 2 Separate quarter panel.
  - A = Separation lines, (Kadett)
- 3 Note size of new part.

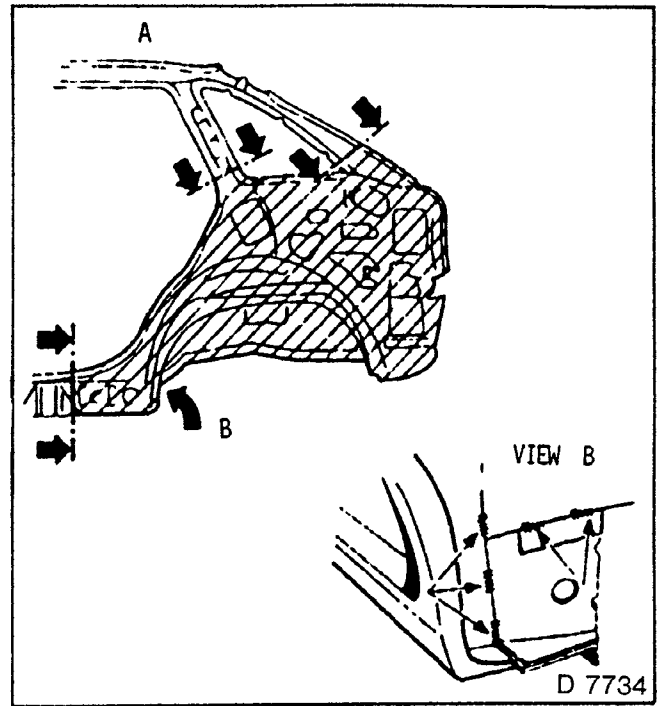


Fig. 76

### INSTALL, CONNECT

1. Fit inner quarter panel
- 2 Prepare inner quarter panel.
3. Apply spot welding paint or spot weld tape.
4. Weld in new part.
- 5 Attaching parts

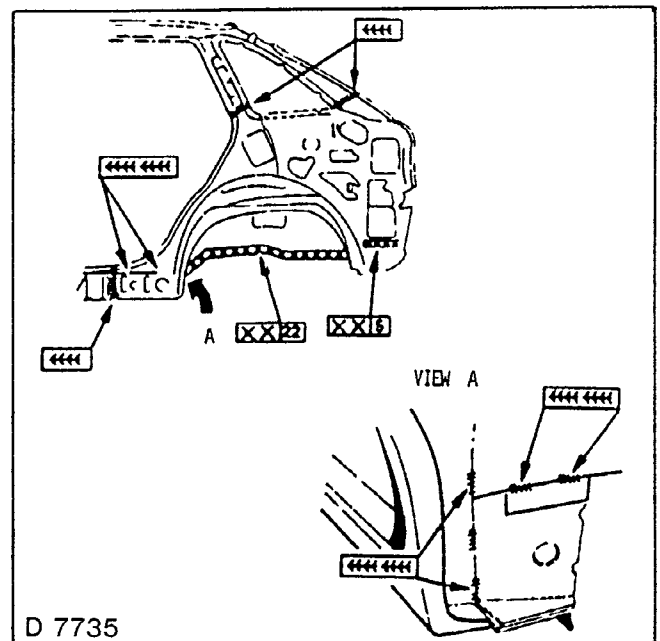


Fig. 77

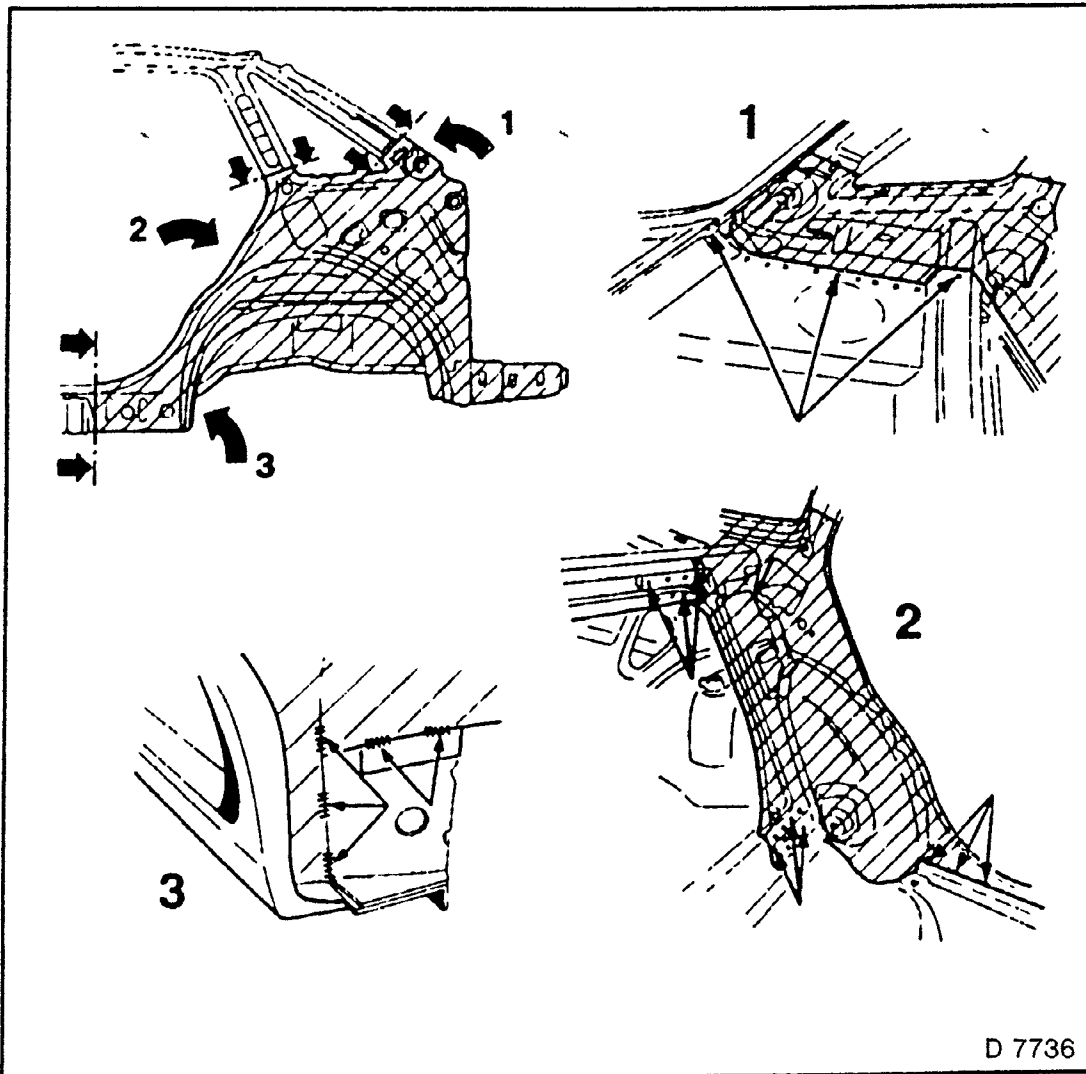
# Rear Section of Inner Rear Quarter Panel — Replace Partially (Astra)

(Additional operation to replacement of outer quarter panel).

Special economy parts are available for partial replacement.

## REMOVE, DISCONNECT

1. Attaching parts.
2. Separate rear quarter panel.
3. Observe size of new part.



D 7736

Fig. 78

**INSTALL, CONNECT**

1. Fit inner rear quarter panel.
2. Prepare inner rear quarter panel.
3. Apply spot welding paint or spot welding tape.
4. Weld in new part.
5. Attaching parts

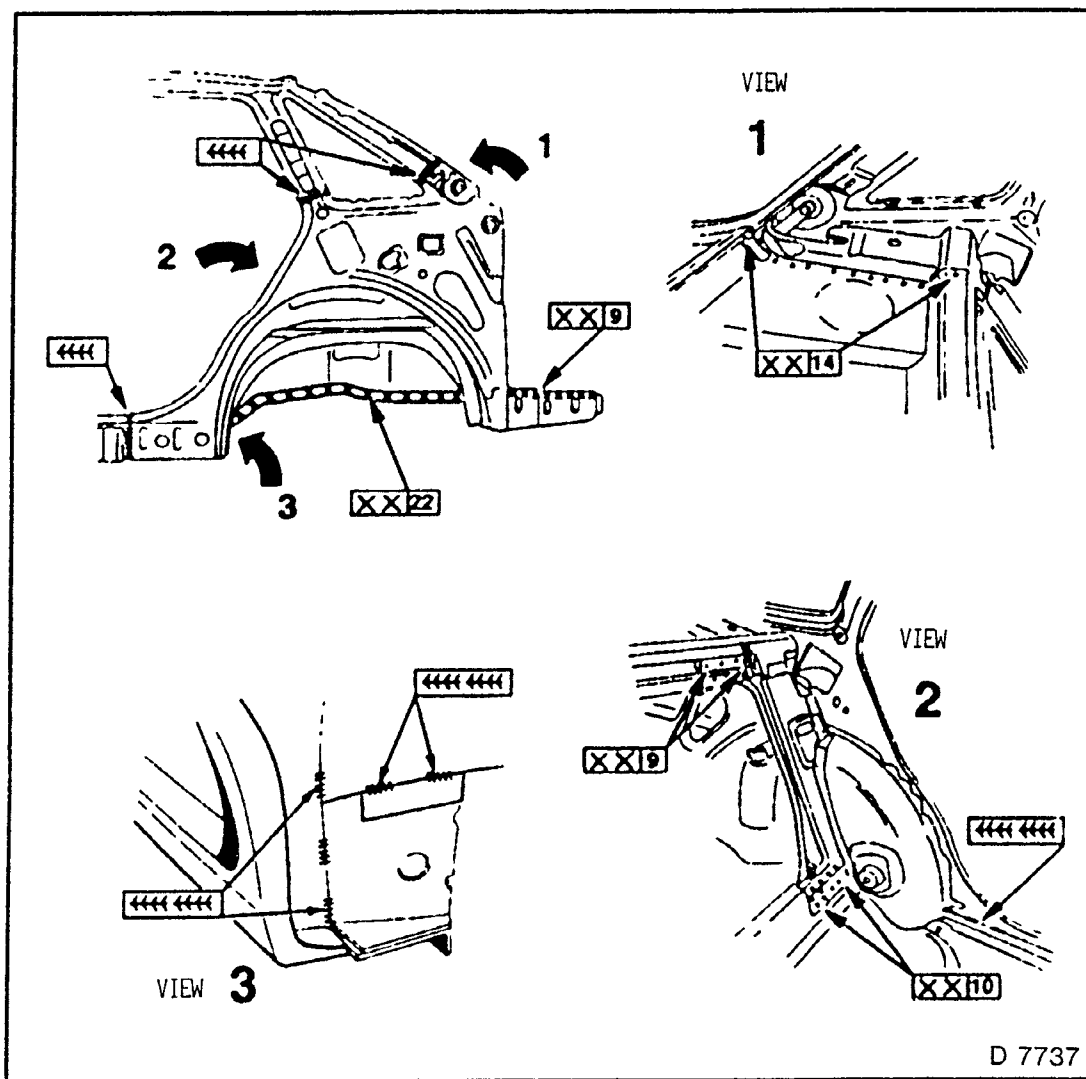


Fig. 79

## Lower Rear End Panel — Replace Completely (Kadett)

### REMOVE, DISCONNECT

1. Attaching parts.
2. Drill off rear end panel.
3. Quarter panel.
4. Floor plate.

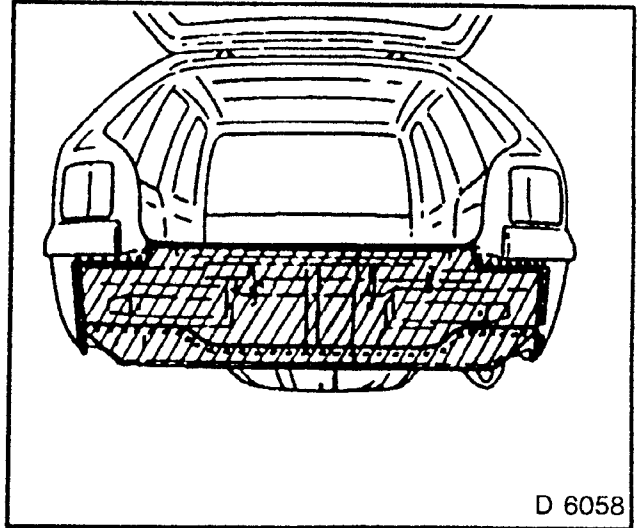


Fig. 80

### INSTALL, CONNECT

1. Fit rear end panel.
- 2 Prepare flange —  
Apply spot welding paint or spot welding tape.
- 3 Weld in rear end panel.
- 4 Seal body seams
- 5 Seal cavities.
6. Attaching parts.

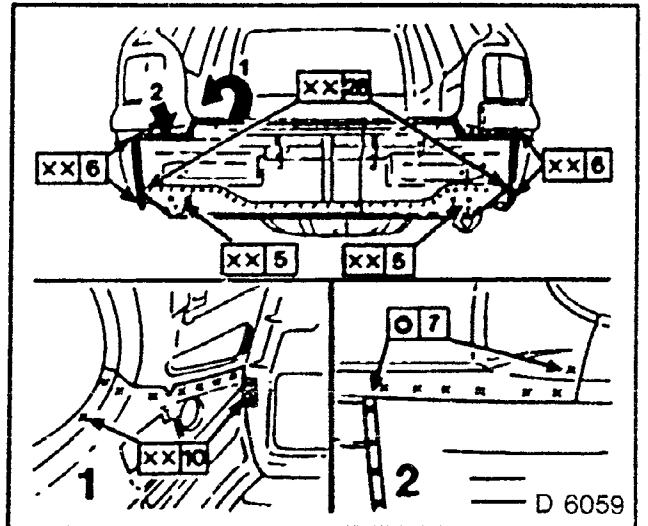


Fig 81

## Lower Rear End Panel — Replace Partially (Kadett)

Special economy parts are available for partial replacement.

Only operations that vary from “Lower Rear End Panel, Replace Completely” are described.

### REMOVE, DISCONNECT

1. Separate rear end panel (damaged side) approximately 100 mm to right of centre of vehicle.
2. Note size of new part.
3. Cutting line applies for right and left partial replacement.

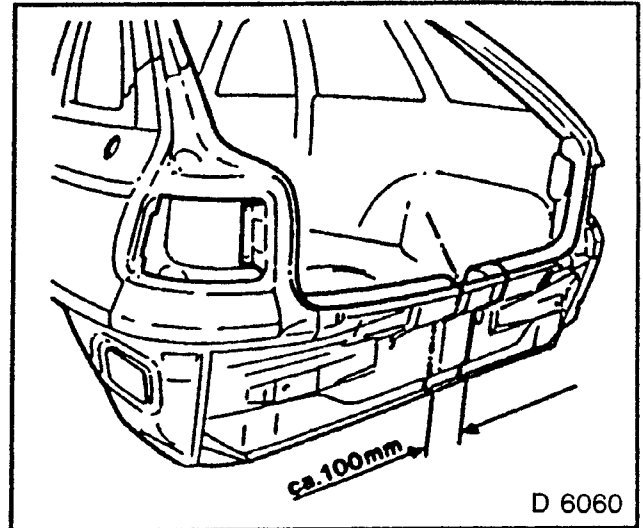


Fig. 82

### INSTALL, CONNECT

1. Butt weld new part at cutting point.

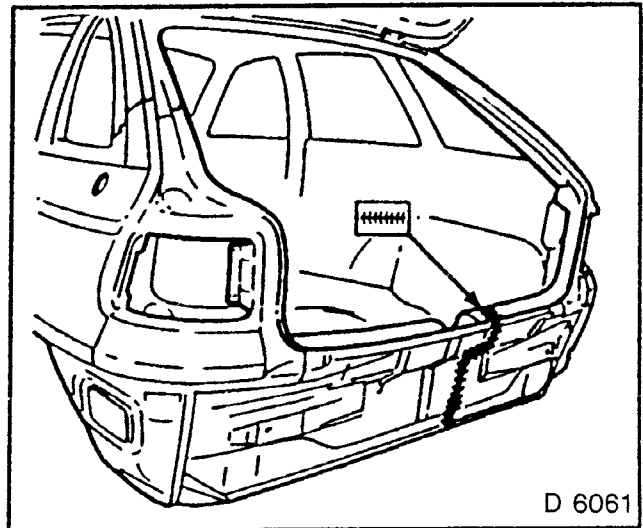


Fig. 83

## Lower Rear End Panel — Replace Completely (Astra)

### REMOVE, DISCONNECT

1. Attaching parts.  
Drill off rear end panel.
2. Rear quarter panel
3. Floor sheet metal.

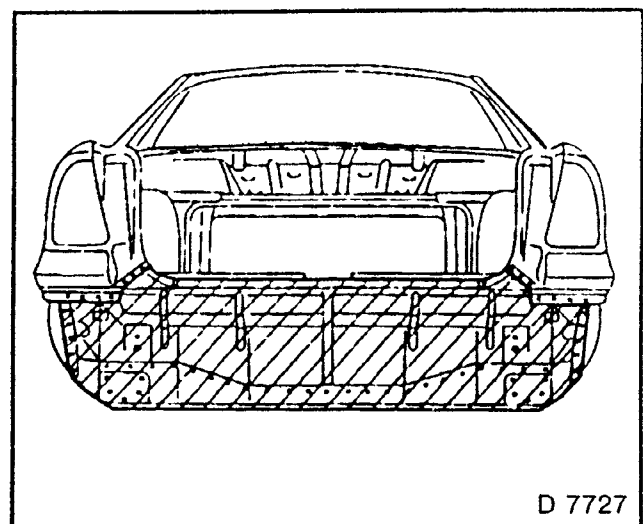


Fig 84

**INSTALL, CONNECT**

1. Fit rear end panel.
2. Prepare flange.  
Apply spot welding paint or spot welding tape.
3. Weld in rear end panel.
4. Seal body seams.
5. Seal cavities.
6. Attaching parts.

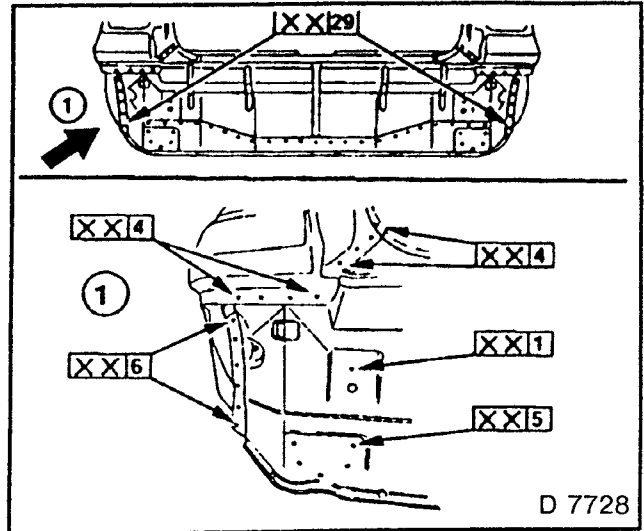


Fig. 85

**Lower Rear End Panel  
— Replace Partially  
(Astra)**

Special economy parts are available for partial replacement.

Only operations that vary from “Lower Rear End Panel, Replace Completely” are described.

**REMOVE, DISCONNECT**

1. Separate rear end panel (damaged side) approximately 100 mm to right of centre of vehicle
2. Note size of new part.
3. Separation point applies for both left and right partial replacement.

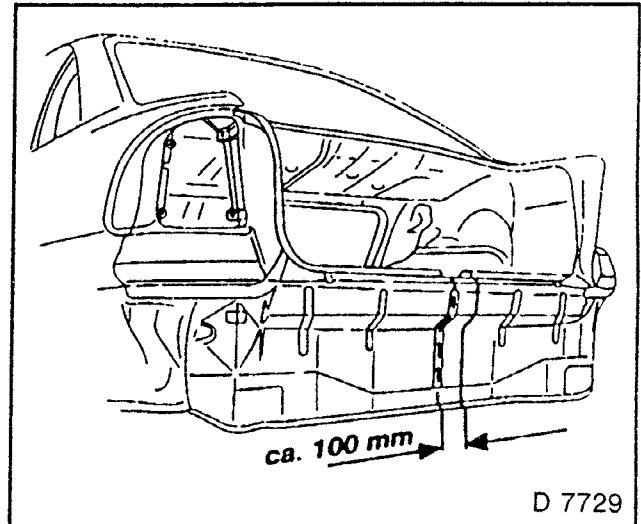


Fig. 86

**INSTALL, CONNECT**

1. Butt weld new part at cutting point

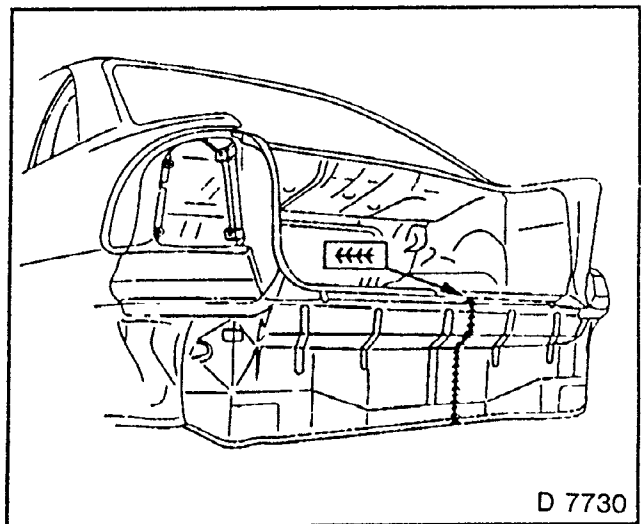


Fig. 87

## Rear Side Member Ends, Replace Both (Kadett)

(Additional operation to "Rear Quarter Panel, Replace" and "Lower Rear End Panel, Replace Completely")

### REMOVE, DISCONNECT

1. Attaching parts.
2. Separate side member (1) and floor (2) according to dimensions given.
3. Note size of new part.

**NOTE:**  
OFFSET OF CUTTING LINE.

### INSTALL, CONNECT

1. Prepare new parts.
2. Fit side member (3).
3. Weld in — use body straightening bench.
4. Fit floor — note body measuring chart.
5. Butt weld in spare wheel recess area.
6. Weld overlapping at side.
7. Weld in rear end panel.
8. Weld in quarter panel.
9. Seal body seams.
10. Seal cavities.
11. Apply corrosion protection.
12. Attaching parts.

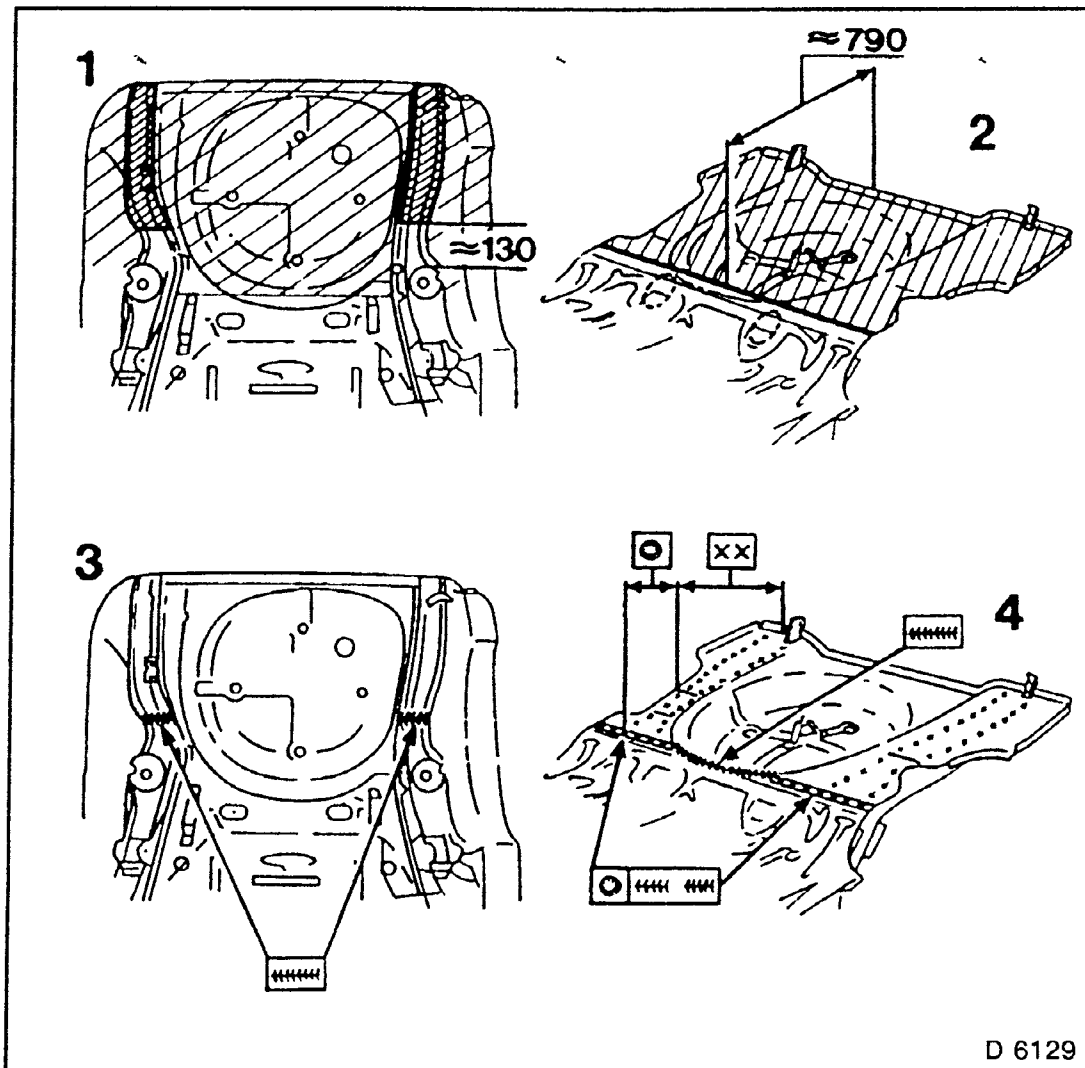


Fig. 88



# Rear Side Member Ends, Replace (Astra)

(Additional operation to "Rear Quarter Panel, Replace" and "Lower Rear End Panel, Replace Completely")

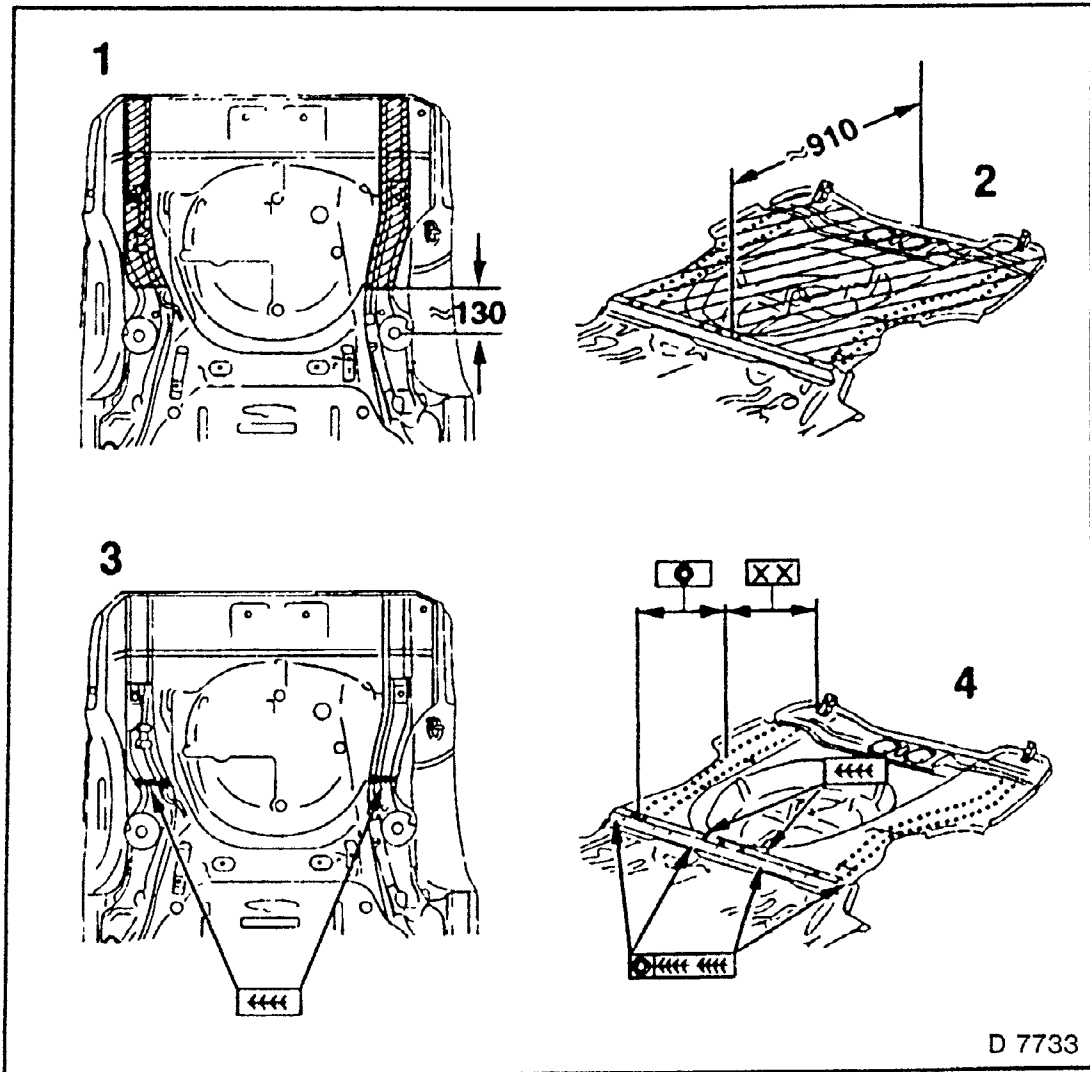
## REMOVE, DISCONNECT

1. Attaching parts.
2. Separate side member (1) and floor (2) according to dimensions given.
3. Note size of new part.

**NOTE:**  
**OFFSET OF CUTTING LINE.**

## INSTALL, CONNECT

1. Prepare new parts.
2. Fit and weld in side member (3) — use body straightening bench.
3. Fit floor.
4. Butt weld in area of spare wheel hollow.
5. Weld overlap at sides.
6. Weld in rear end panel.
7. Weld in quarter panel.
8. Seal body seams
9. Seal cavities.
10. Apply corrosion protection
11. Attaching parts.



D 7733

Fig. 89

## Roof Panelling — Replace (Kadett)

### REMOVE, DISCONNECT

1. Attaching parts.
2. Separate roof panelling.
- 3 Drill off welding points (approximately 122).

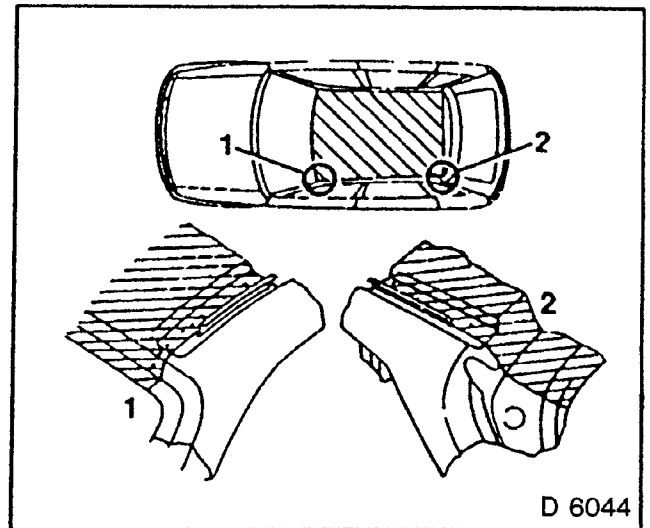


Fig. 90

### INSTALL, CONNECT

- 1 Fit new part.
2. Apply spot welding paint or spot welding tape
3. Weld in roof panelling.
- 4 Seal body seams.
- 5 Seal cavities.
6. Attaching parts

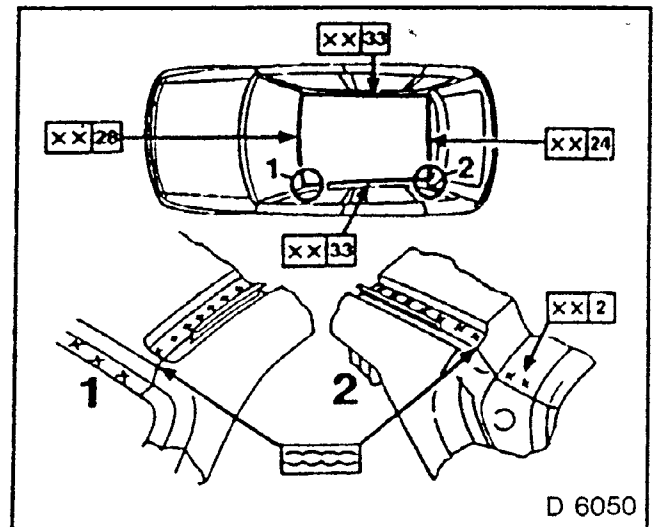


Fig. 91

# Roof Panelling — Replace (Astra)

## REMOVE, DISCONNECT

1. Attaching parts.
2. Separate roof panelling.
3. Drill off welding points (approximately 122).

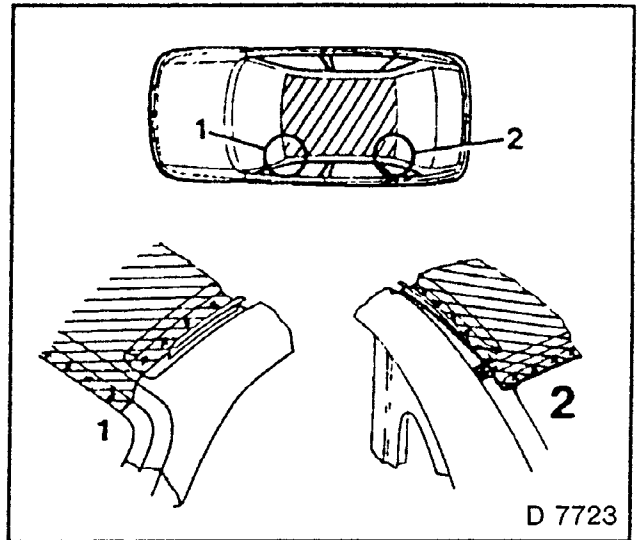


Fig. 92

## INSTALL, CONNECT

1. Fit new part.
2. Apply spot welding paint or spot welding tape.
3. Weld in roof panelling
4. Seal body seams.
5. Seal cavities.
6. Attaching parts.

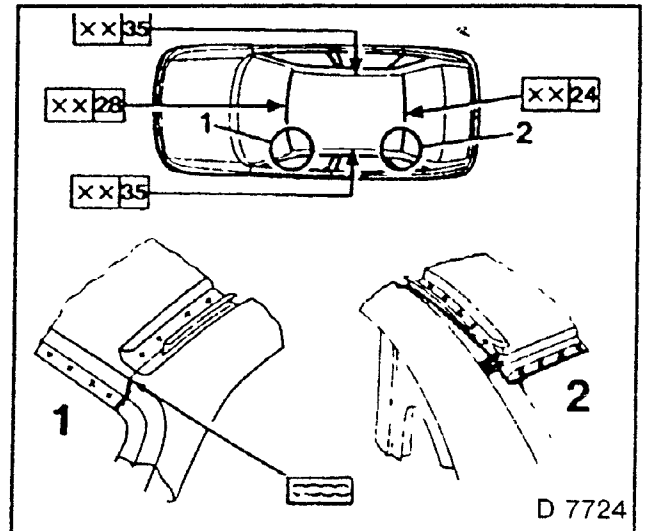
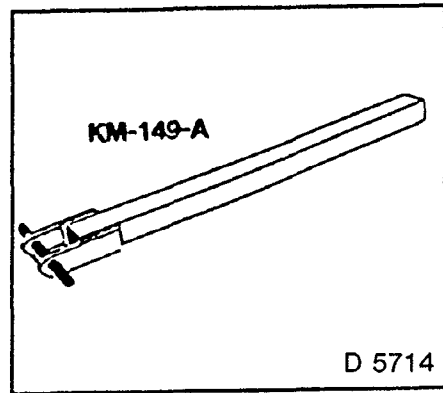


Fig. 93

## SPECIAL SERVICE TOOLS

### KM — 149 — A      ALIGNER.

To align the door hinge eyes.

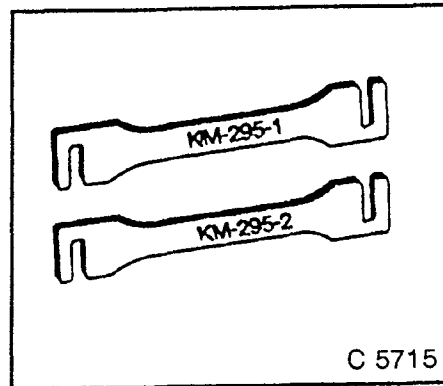


### KM — 295 — 1      ALIGNER, FRONT.

To align the door hinges on front door

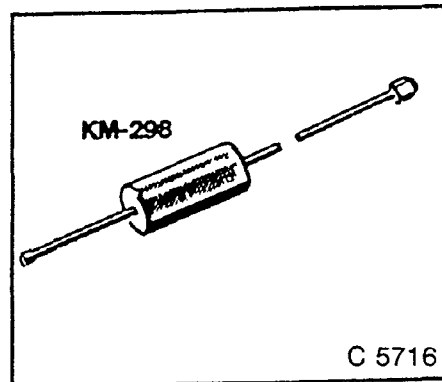
### KM — 295 — 2      ALIGNER, REAR.

To align the door hinges on rear door.



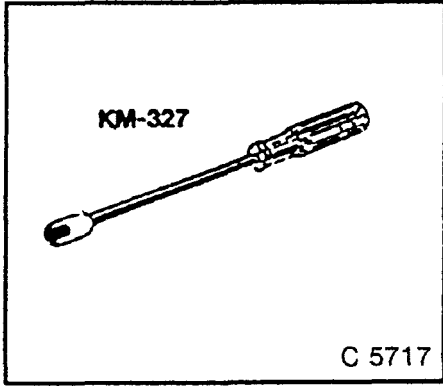
### KM — 298      PIN REMOVER.

To remove the door hinge pin



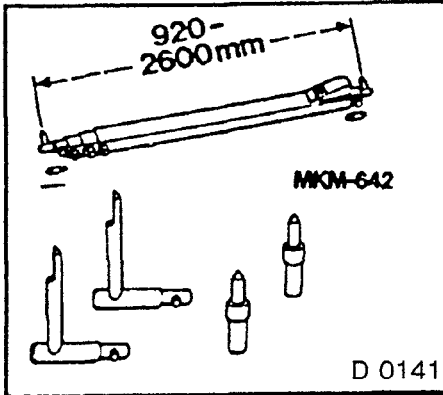
**KM — 327      CAP REMOVER.**

To remove and install the door hinge cap.

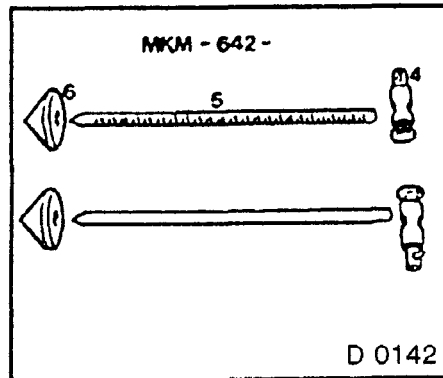


**MKM — 642 — A      TELESCOPIC MEASURING DEVICE (WITH ANGLE PIECE AND POINT).**

To measure the body  
(Measuring range. 920 — 2 600 mm)



**MKM — 642 — 4      ADAPTOR.  
MKM — 642 — 5      EXTENSION.  
MKM — 642 — 6      CONE.**



# **Opel Astra Opel Kadett**

## **Workshop Manual**

### **Section B**

### **Paint**

Issued by: Service Division  
Delta Motor Corporation  
July, 1993

# Index

	<i>Page</i>
GENERAL INFORMATION .....	B-2
EXPLANATION OF TIME ALLOWANCE PAINTING STAGES I, II AND III .....	B-7
NEGATIVE INFLUENCES ON VEHICLE PAINT .....	B-3
PAINT REPAIRS .....	B-4
PAINTING OF PLASTIC PARTS .....	B-6
PROCEDURE FOR PAINT REPAIRS .....	B-5
VEHICLE IDENTIFICATION PLATE .....	B-6

## GENERAL INFORMATION

Preconditions for attaining optimal paint results, besides a thorough knowledge of products and processes, are cleanliness of the equipment, working area and the surface to be painted. Ensure that the compressed air used is absolutely free of oil and water particles.

Use of DELTA approved materials ensures optimal suitability of paint products.

For these operations and processing of materials, observe the safety regulations and information regarding health and environmental protection guidelines provided by the relevant institutions.

- Always process paints, primer and filler in painting booths.
- Avoid naked flames and sparks.
- An adequate number of fire extinguishers must be on hand.
- Use dust masks, active carbon masks or oxygen masks, depending on the type of operation being carried out.
- When dry-sanding, use sanding machines with an integrated vacuum unit.
- Paint and solvent residues, vacuum unit filter, sanding dust, etc. must be disposed of according to regulations.
- All vehicle parts that are not being worked on should be masked during painting operations to prevent damage and dirt.



## NEGATIVE INFLUENCES ON VEHICLE PAINT

The painting of a vehicle not only improves its appearance, but also protects it from various environmental influences and corrosion.

The most common negative influences on paint are:

### **CLIMATIC INFLUENCES:**

Climatic influences include rain, snow, humidity, salt content in air, UV rays, heat, cold volume enlargement and diminution of the paintwork and the formation of condensation in the vehicle's cavities. These influences also count as natural ageing.

### **MECHANICAL INFLUENCES:**

Mechanical influences include the abrasion of dust and sand combined with the wind created by driving. In addition, contributions are made by the impact of scattered materials.

Washing and cleaning agents in the wash system or when washing by hand, polishes and polishing methods all count as mechanical influences.

### **INDUSTRIAL INFLUENCES:**

Industrial influences include so-called acid rain or acid condensation. Numerous additional factors include pesticides and weedkillers, concrete or cement dust, powdered lime and whitening sprayer, mortar spray, spray from house painting materials or silicon resin, house waterproofing agents, drops of paint remover, metal abrasion in metallic or corroded form, fluids such as brake fluid, solvent, battery acid, certain oils and recrement from furnaces.

### **BIOLOGICAL INFLUENCES:**

The most common causes of damage under the heading of biological influences include bird droppings, dead insects and their secretions, greenfly excrement, discolourations from blossom, buds, pollen, leaves and sap. Flour or grain dust and fodder remains are also included in this group.

## PAINT REPAIRS

### GENERAL

To ensure that paint repair operations progress efficiently, the relevant work factors — from when the vehicle is received until when it is returned — must be observed with extra care. As each workshop has its own structure, the operation plan suggested here is only a recommendation.

### RECEPTION: (SERVICE ADVISOR)

Assess damage or blemishes. Consider possibilities and limitations of spray technique.

Motivate customer; assess main and additional operations.

Estimate cost and produce work order.

Read Time Allowance catalogue correctly; complete order conscientiously.

The body worker must provide the basis for a paintable surface so that the painter can carry out his/her work according to the paint stages and processing regulations in question.

### PAINT: (PAINTER)

Read work order carefully.

Assess damage.

Determine vehicle paint type from vehicle identification plate.

Determine plastic type.

Co-ordinate sanding equipment to be used.

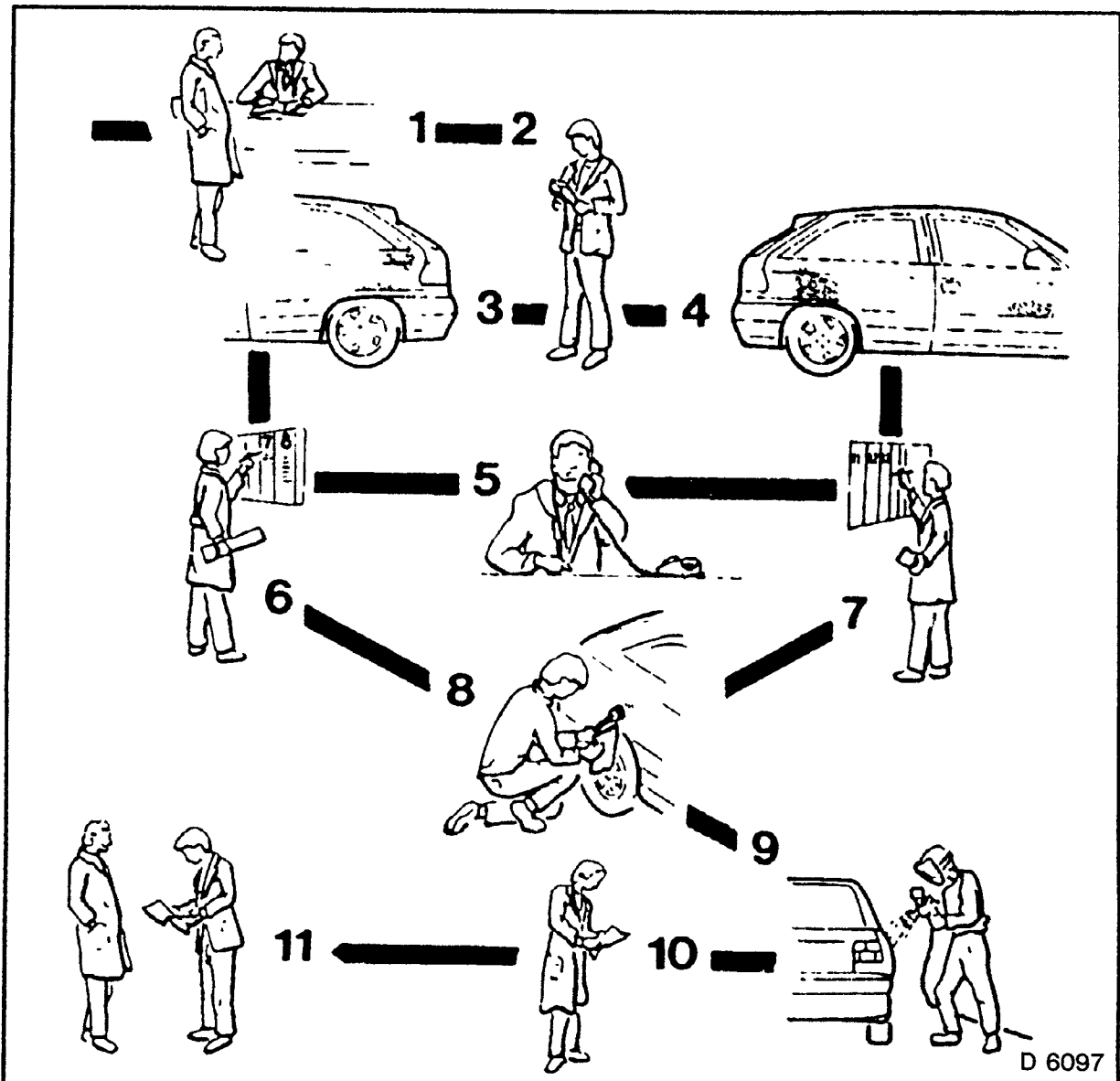
Select priming and filling materials according to economic considerations.

Determine economical paint application.

Utilize spray technique.

# PROCEDURE FOR PAINT REPAIRS

- 1 = Reception of vehicle
- 2 = Assessment of paint surface
- 3 = Small damage
- 4 = Larger damage
- 5 = Preparation of work order
- 6 = Preparations for painting (without sheet metal work)
- 7 = Sheet metal work with subsequent preparations for painting
- 8 = Colour check
- 9 = Paintshop
- 10 = Final check
- 11 = Return to customer



D 6097

Fig. 1

## Vehicle Identification Plate

The vehicle identification plate includes information about the colour of the vehicle.

Check information on vehicle identification plate.

Example: 08E = "Casablanca White" enamel paint.


 <b>DELTA MOTOR CORPORATION (PTY) LTD</b>					
<b>VIN</b> NO NR					
PAINT VERF			BOARD COMPUTER CODE		
TRIM STOFFERING					
G.C.M.	kg	P/D	kw	G.V.M.	kg
B.K.M.				B.V.M.	
D/T	kg	T	kg	V	kg
G.A.1	kg	G.A.2	kg	G.A.3	kg
B.A.1		B.A.2		B.A.3	
A1	kg	A2	kg	A3	kg

Fig. 2

## Painting of Plastic Parts

All plastic parts are marked on the reverse side with an abbreviation according to the type of plastic used (e.g. PUR = Polyurethane). To guarantee adequate paint adhesion, the paint system corresponding to the material must be used.

Avoid spraying thick layers of paint on plastic parts. Thick layers of paint can alter the properties of the plastic.

Material of painted plastic parts on vehicle and corresponding paint system:

	Paint system
1 = Polyurethane (PUR hard)	3,4
2 = Polyamide (PA)	3,4
3 = Primed polypropylene (PP/EPDM)	3,4
4 = Acrylonitrile-butadiene-styrene (ABS)	3,4

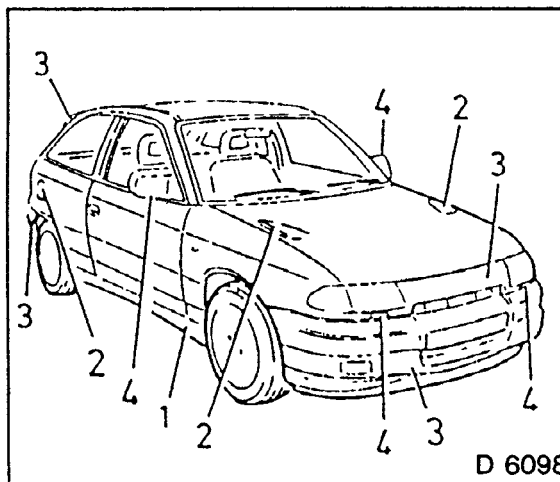


Fig. 3

## Explanation of Time Allowance Painting Stages I, II and III

The time allowances for major and combination painting operations are divided into painting stages.

Painting stage	Description
I	Painting new components. Coat complete surface. Fill complete surface. Partially apply putty on weld-in parts.
II	Painting surfaces. Coat complete surface, including small improvements (without applying putty).
III	Paint repair. Coat complete surface. Fill working surface. Partially apply putty to up to 50% of surface to be painted.

# **Opel Astra** **Opel Kadett**

## **Workshop Manual**

### **Section C**

# **Body Equipment**

Issued by: Service Division  
Delta Motor Corporation  
July, 1993

# Index

*Page*

**GLASS, WINDOW GUIDES, WINDOW WINDERS**

DOOR UPPER WINDOW GUIDE, REMOVE AND INSTALL .....	C-13
FRONT DOOR SASH WINDOW, REMOVE AND INSTALL (MANUAL AND ELECTRIC ACTUATION) ...	C-10
FRONT DOOR WINDOW ACTUATION, REMOVE AND INSTALL (ELECTRIC).....	C-12
FRONT DOOR WINDOW ACTUATION, REMOVE AND INSTALL (MANUAL) .	C-11
REAR DOOR SASH WINDOW, REMOVE AND INSTALL .....	C-11
REAR DOOR WINDOW ACTUATION, REMOVE AND INSTALL....	C-13
REAR QUARTER WINDOW, REMOVE AND INSTALL.....	C-14
REAR SCREEN, REMOVE AND INSTALL OR REPLACE (ASTRA).....	C- 7
RETAINING PLATE FOR REAR VIEW MIRROR, SERVICE CEMENT....	C- 9
TAILGATE SCREEN, REMOVE AND INSTALL OR REPLACE (KADETT) ..	C- 5
WINDSCREEN, REMOVE AND INSTALL OR REPLACE. ....	C- 3

**TRIM MOULDINGS, LETTERINGS, FITTINGS, HINGES**

FRONT DOOR LOCK CYLINDER, REMOVE AND INSTALL.....	C-15
FRONT DOOR LOCK, REMOVE AND INSTALL.....	C-16
FRONT DOOR OUTSIDE HANDLE, REMOVE AND INSTALL....	C-15
GLOVE COMPARTMENT LID LOCK CYLINDER, REMOVE AND INSTALL. ....	C-19
LUGGAGE COMPARTMENT LID LOCK CYLINDER, REMOVE AND INSTALL — (ASTRA) .. .	C-18
LUGGAGE COMPARTMENT LID OUTSIDE HANDLE, REMOVE AND INSTALL — (ASTRA) ....	C-17
LUGGAGE COMPARTMENT LOCK, REMOVE AND INSTALL — (ASTRA) .....	C-19
REAR DOOR LOCK, REMOVE AND INSTALL .....	C-17
REAR DOOR OUTSIDE HANDLE, REMOVE AND INSTALL .....	C-16
ROOF COVER STRIP, REMOVE AND INSTALL . . . . .	C-21
SIDE PROTECTIVE TRIM STRIPS, REPLACE. . . . .	C-20
TAILGATE HINGE, REMOVE AND INSTALL .....	C-20
TAILGATE LOCK CYLINDER, REMOVE AND INSTALL — (KADETT) .....	C-18
TAILGATE LOCK, REMOVE AND INSTALL — (KADETT).....	C-18
TAILGATE OUTSIDE HANDLE, REMOVE AND INSTALL — (KADETT)....	C-17

**SEATS, UPHOLSTERY, INNER PANELLING**

A PILLAR UPPER PANELLING, REMOVE AND INSTALL..	C-37
B PILLAR PANELLING, REMOVE AND INSTALL....	C-37
BELT LOCK TENSIONER, REMOVE AND INSTALL OR REPLACE .....	C-26

	<i>Page</i>
C/D PILLAR PANELLING, REMOVE AND INSTALL — (ASTRA) .....	C-38
C/D PILLAR PANELLING, REMOVE AND INSTALL — (KADETT) .....	C-38
CENTRE CONSOLE, REMOVE AND INSTALL .....	C-37
FRONT DOOR INNER PANELLING, REMOVE AND INSTALL .....	C-22
FRONT SEAT BACKRESTS, REMOVE AND INSTALL .....	C-28
FRONT SEAT, REMOVE AND INSTALL .....	C-25
HEADREST GUIDE SLEEVE, REMOVE AND INSTALL .....	C-30
INSTRUMENT PANEL PADDING, REMOVE AND INSTALL .....	C-35
MOULDED HEADLINING, REMOVE AND INSTALL OR REPLACE .....	C-35
REAR DOOR INNER PANELLING, REMOVE AND INSTALL .....	C-22
REAR END LOWER PANELLING, REMOVE AND INSTALL .....	C-41
REAR END PANEL SHELF, REMOVE AND INSTALL — (ASTRA) .....	C-40
REAR QUARTER PANELLING REAR SECTION, REMOVE AND INSTALL (ASTRA) .....	C-40
REAR QUARTER PANELLING REAR SECTION, REMOVE AND INSTALL (KADETT) .....	C-40
REAR SEAT BACKREST, REMOVE AND INSTALL .....	C-29
REAR SEAT HEADREST, SERVICE INSTALL .....	C-31
REAR SEAT, REMOVE AND INSTALL .....	C-29
REAR WHEEL WELL PANELLING, REMOVE AND INSTALL — (ASTRA) .....	C-41
RUBBER DOOR SEAL, REMOVE AND INSTALL OR REPLACE .....	C-23
SEAT BELT, FRONT, REMOVE AND INSTALL OR REPLACE .....	C-43
SEAT BELT, REAR, REMOVE AND INSTALL OR REPLACE .....	C-44
SILL PANELLING SEAL, REMOVE AND INSTALL .....	C-24
SILL PANELLING, FRONT, REMOVE AND INSTALL .....	C-39
SILL PANELLING, REAR, REMOVE AND INSTALL .....	C-39
TAILGATE PANELLING, REMOVE AND INSTALL .....	C-42
UPHOLSTERY COVER FOR ARMREST, REMOVE AND INSTALL OR REPLACE .....	C-34
UPHOLSTERY COVER FOR FRONT SEAT BACKREST, REMOVE AND INSTALL OR REPLACE .....	C-32
UPHOLSTERY COVER FOR FRONT SEAT, REMOVE AND INSTALL OR REPLACE .....	C-31
UPHOLSTERY COVER FOR REAR SEAT BACKREST, REMOVE AND INSTALL OR REPLACE .....	C-33
UPHOLSTERY COVER FOR REAR SEAT, REMOVE AND INSTALL OR REPLACE .....	C-33
<b>SPECIAL SERVICE TOOLS</b> .....	<b>C-45</b>
<b>TECHNICAL DATA</b> .....	<b>C-49</b>



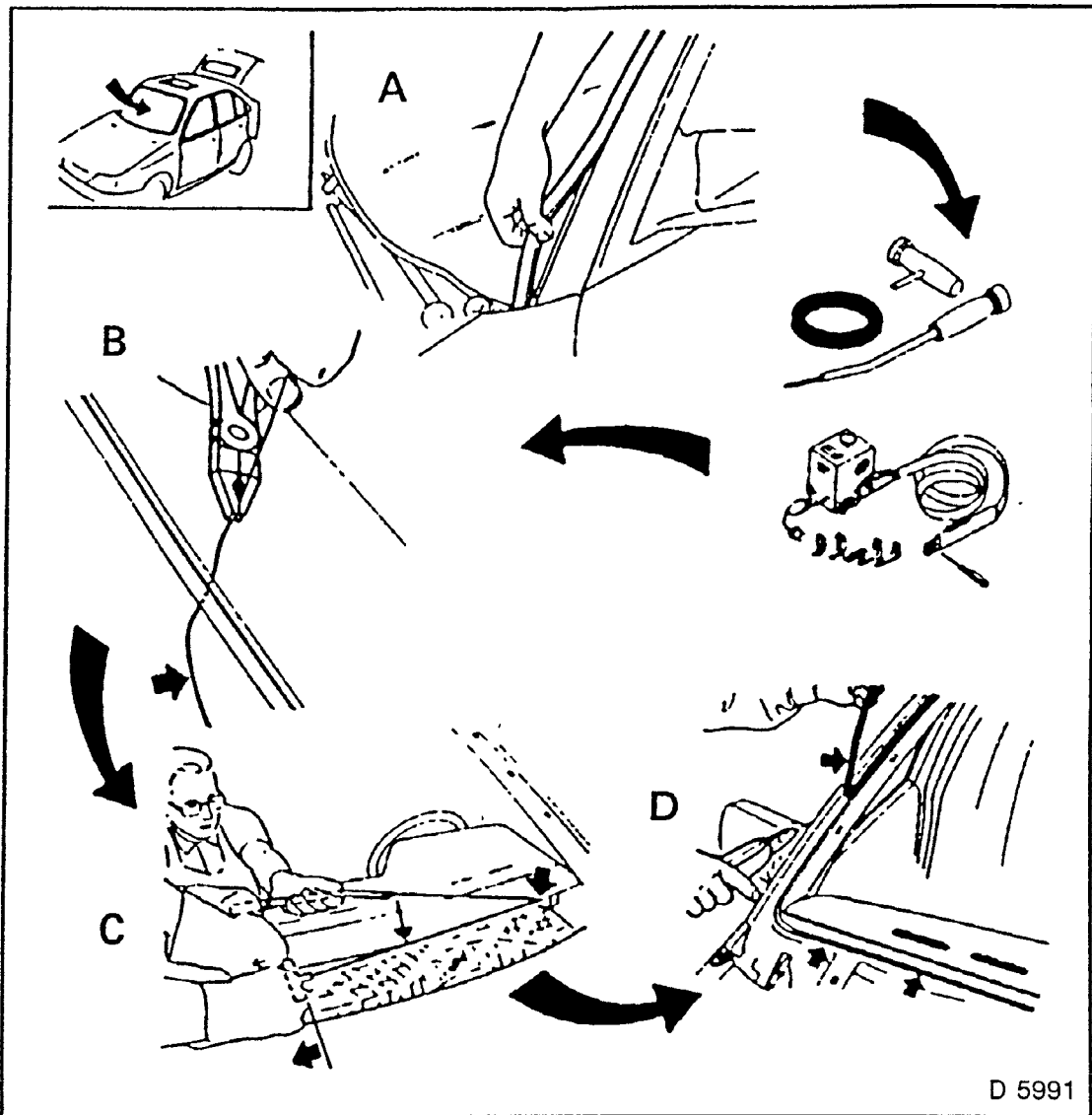


Fig 1

## GLASS, WINDOW GUIDES, WINDOW WINDERS

### Windscreen — Remove and Install or Replace

#### REMOVE, DISCONNECT

- 1 Wind protection panelling.
2. A pillar panelling.
  - a) Screen trim moulding, eccentric.

**NOTE:**

**Removers (alternatively);**  
**Wire Cutter MKM — 589 or**  
**Thermo Knife MKM — 590 — A**  
**Rough cut with type 18 mm.**  
**Recut with type 22 mm.**

- b) Insert wire.
- c) Cut out screen.

**WARNING:**  
**WEAR PROTECTIVE GOGGLES**  
**AND PROTECTIVE GLOVES.**

- d) Cut rest of cement bead to approximately 1 mm thickness  
 If necessary:  
 Eliminate paint damage on screen frame. See Section B.

D 5991

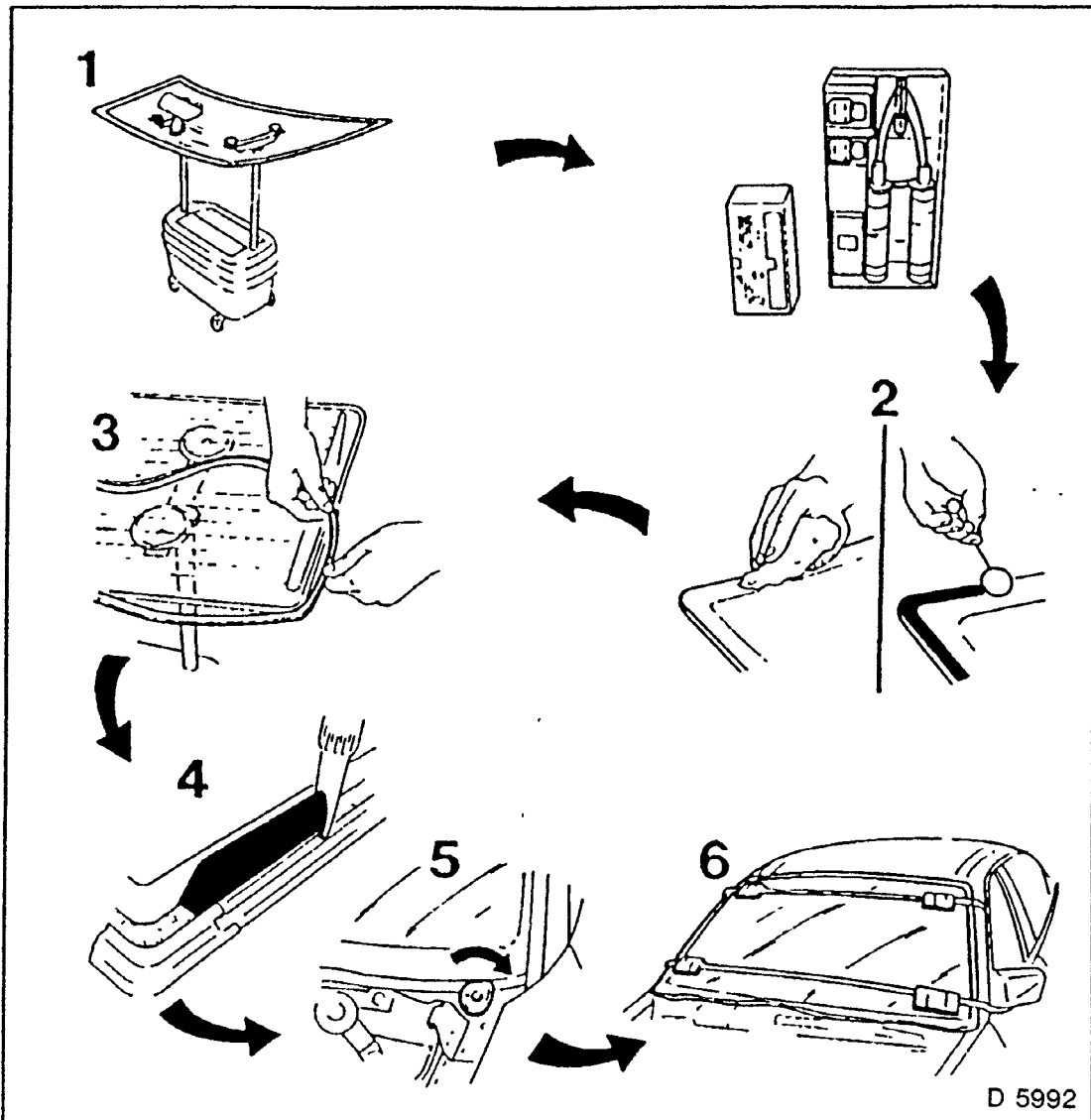


Fig 2

## INSTALL, CONNECT

1 Screen on holder.

### NOTE:

**Use 2-component Cementing Kit**

Observe operation instructions!

2 Clean cementing area and degrease. Apply glass primer (not on old screen)

3 Place trim strip on edge of screen.

4 Apply cement to screen.

5 Insert screen immediately in frame. Adjust height with eccentric

6 Fix screen with two Tension Belts MKM — 591 — do not tension too tight!

Ready for operation after one hour.

7 Wind protection panelling.

8. A pillar panelling.

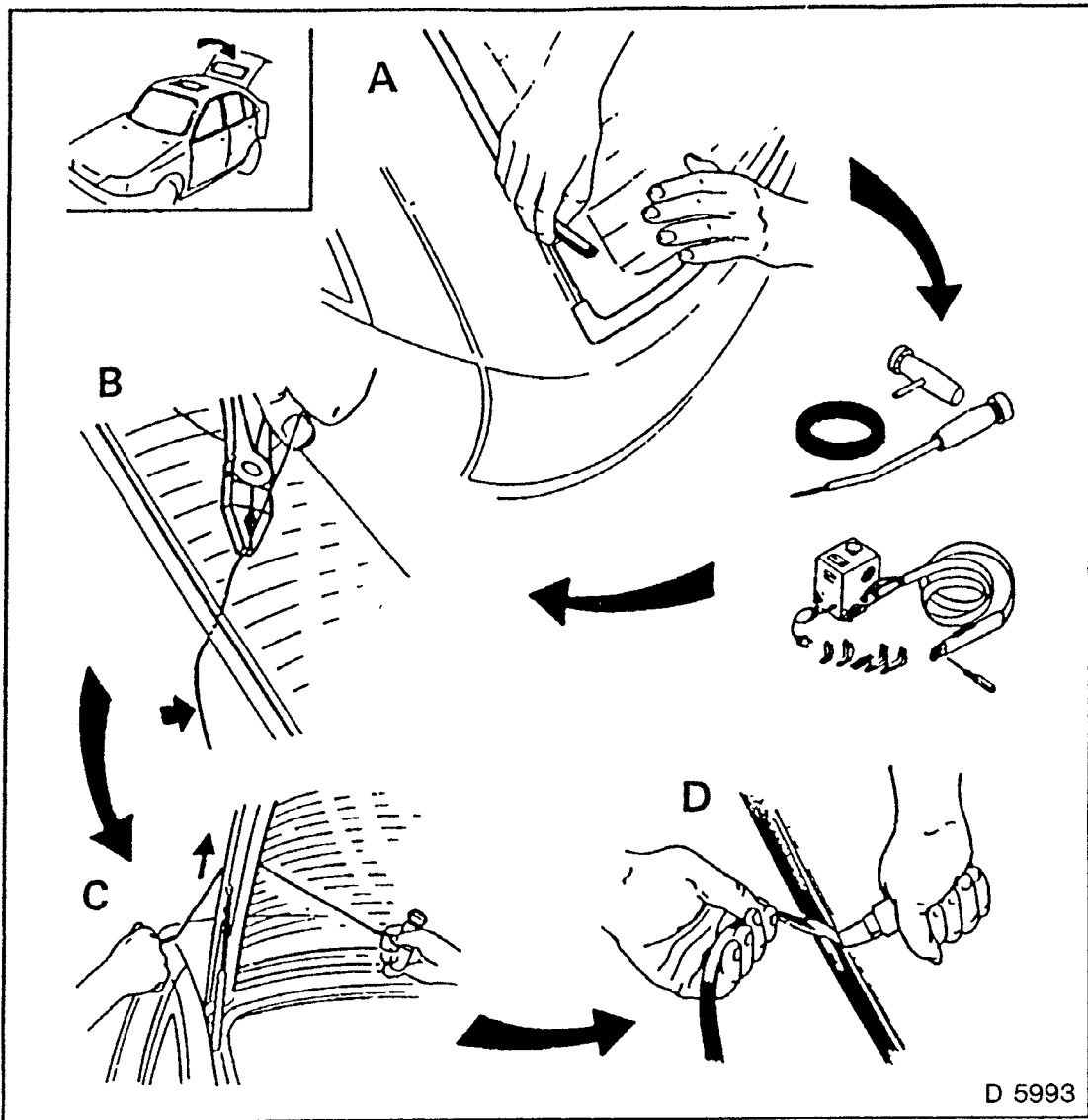


Fig 3

## Tailgate Screen — Remove and Install or Replace (Kadett)

### REMOVE, DISCONNECT

1. Tailgate panelling
2. Rear screen wiper, rear spoiler — if present.
  - a) Screen trim strip

### NOTE:

Removers (alternately)  
 Wire Cutter MKM 589 or  
 Thermo Knife MKM — 590 — A  
 Cut out with type 22 mm.

- b) Insert wire
- c) Cut out screen.

### WARNING WEAR PROTECTIVE GOGGLES AND PROTECTIVE GLOVES.

- d) Cut rest of cement bead to approximately 1 mm thickness.

If necessary:  
 Eliminate paint damage on screen frame. See Section B.

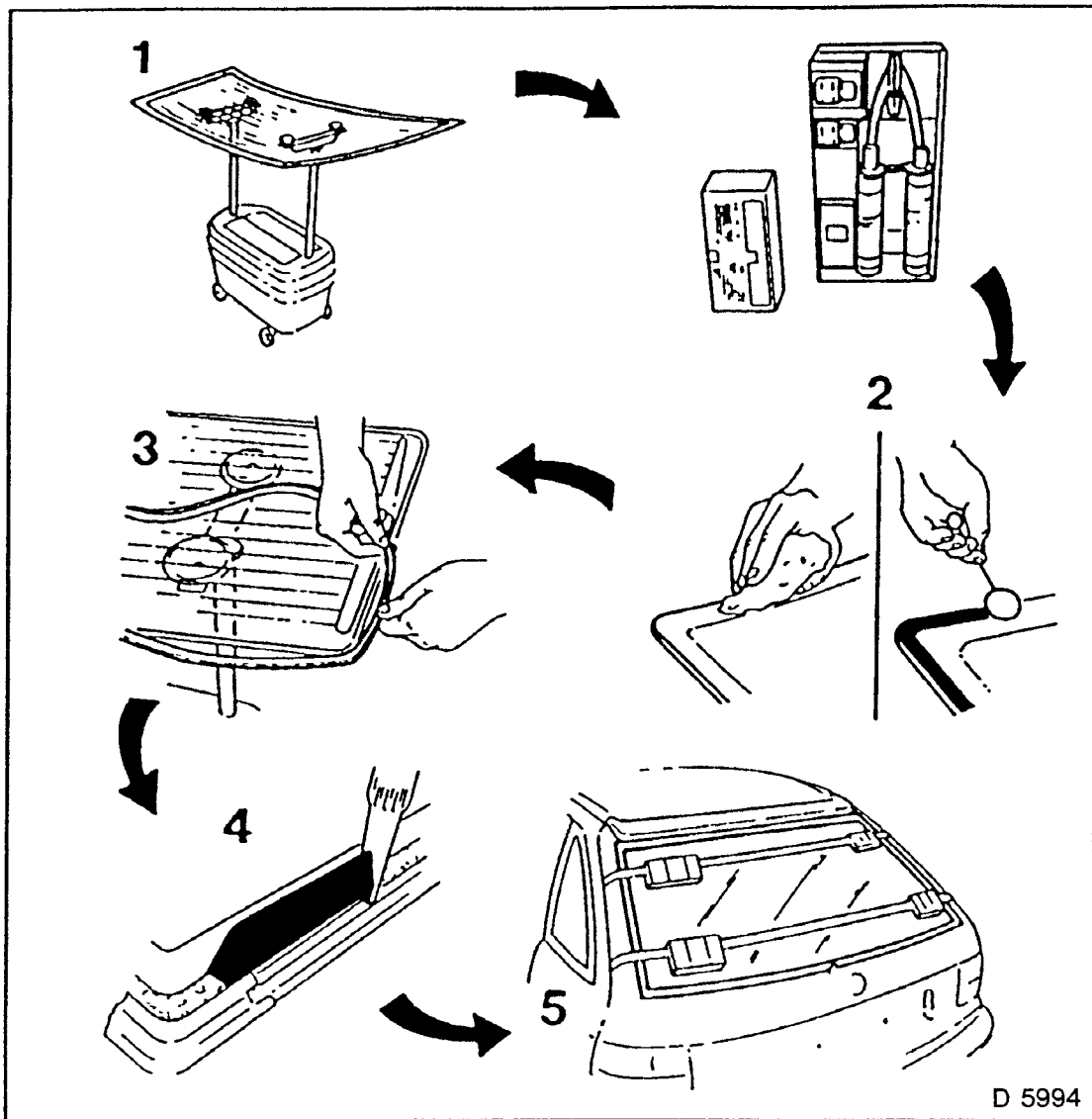


Fig 4

D 5994

## INSTALL, CONNECT

1. Screen on holder.

### NOTE:

#### Use 2-component Cementing Kit

Observe operation instructions!

2. Clean cementing area and degrease. Apply glass primer (not on old screen)
3. Place trim strip on edge of screen.
4. Apply cement to screen.
5. Insert screen immediately in frame and fix with two Tensioning Belts MKM — 591 — do not tension too tight.

Ready for operation after one hour

6. Panelling.
7. Rear screen wiper.
8. Rear Spoiler.

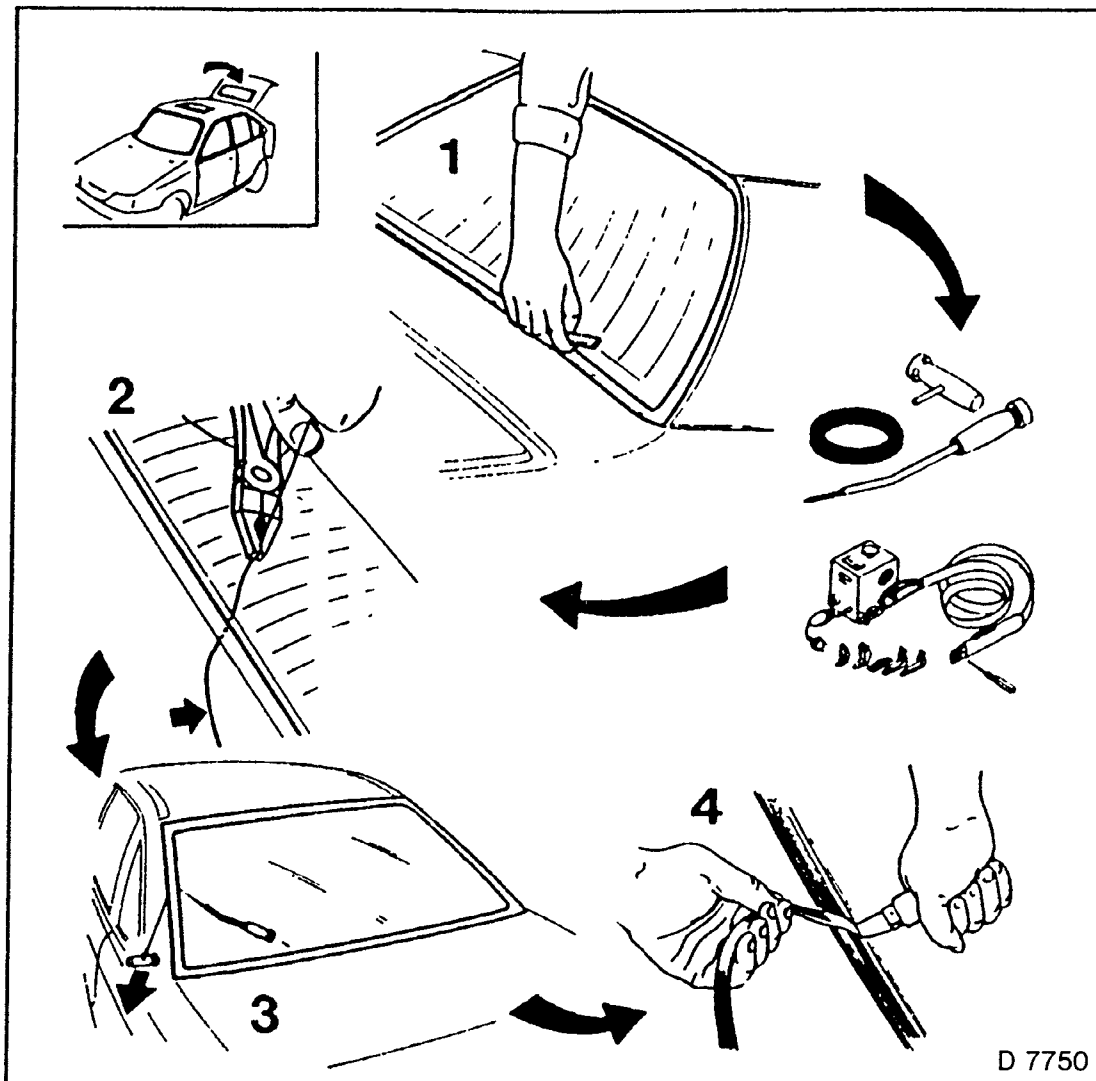


Fig 5

D 7750

## Rear Screen — Remove and Install or Replace (Astra)

### REMOVE, DISCONNECT

- Rear end panel shelf.
- Panelling — C/D pillars.
- Disconnect heated rear screen wiring plug.
- Close luggage compartment lid.
- Mask edges in working area.

- Screen trim strip.

### NOTE:

Removers (alternately)  
 Wire Cutter MKM — 589 or  
 Thermo Knife MKM — 590 — A  
 Cut out with type 22 mm

- Insert wire.
- Cut out screen.

### WARNING WEAR PROTECTIVE GOGGLES AND PROTECTIVE GLOVES.

- Cut rest of cement bead to approximately 1 mm thickness

If necessary:  
 Eliminate paint damage on screen frame. See Section B.

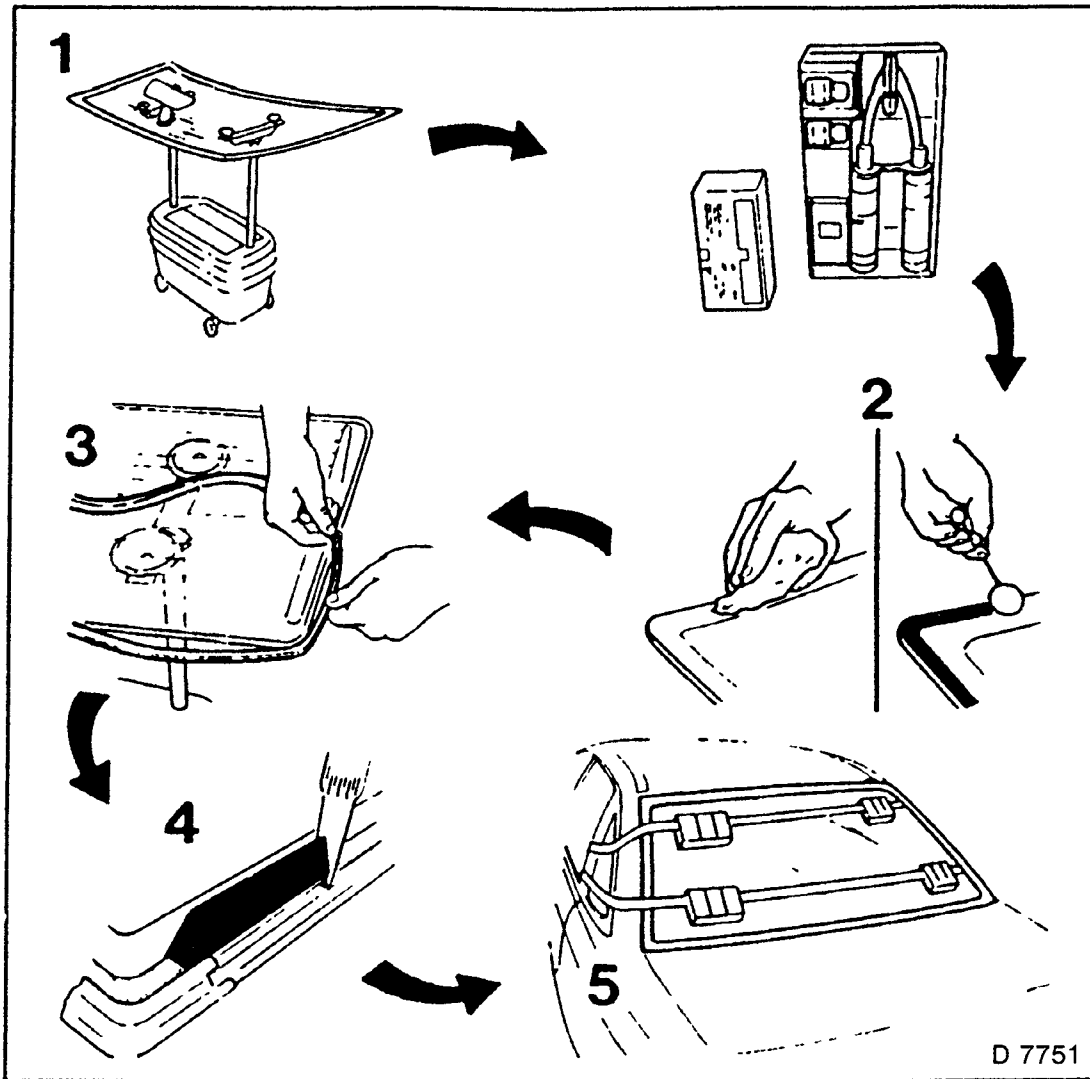


Fig 6

D 7751

## INSTALL, CONNECT

1 Screen on holder.

### NOTE:

Use 2-component Cementing Kit

Observe operation instructions!

2 Clean cementing area and degrease. Apply glass primer (not on old screen).

3. Place trim strip on edge of screen.

4. Apply cement to screen.

5. Insert screen immediately in frame and fix with two Tensioning Belts MKM — 591 do not tension too tight.

Ready for operation after one hour

6. Connect wiring plug.

7 C/D pillar panelling.

8. Rear end panel shelf.

# Retaining Plate for Rear View Mirror, Service Cement

## REMOVE, DISCONNECT

1. Rear view mirror — from retaining plate.
2. Retaining plate.
  - a) Grind slightly (grain P 100) and clean.
  - b) Clean screen in cementing area — Glass Cleaner.

## INSTALL, CONNECT

1. Localize cementing area with Masking Tape.
2. Mix Two Component Adhesive and apply with fine toothed spatula.
3. Join cementing parts and fix with masking tape;
 

Cement is ready to be installed after eighty minutes at room temperature; when heated to maximum 80°C/176°F setting time is shortened.
4. Fasten cementing area for mirror base.
 

A — 95 mm (from edge of moulded headlining).

B — Middle of screen.
5. Position rear view mirror

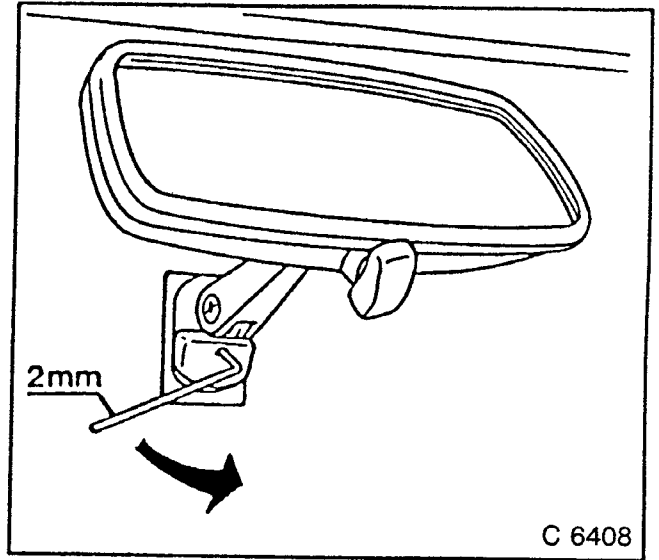


Fig 7

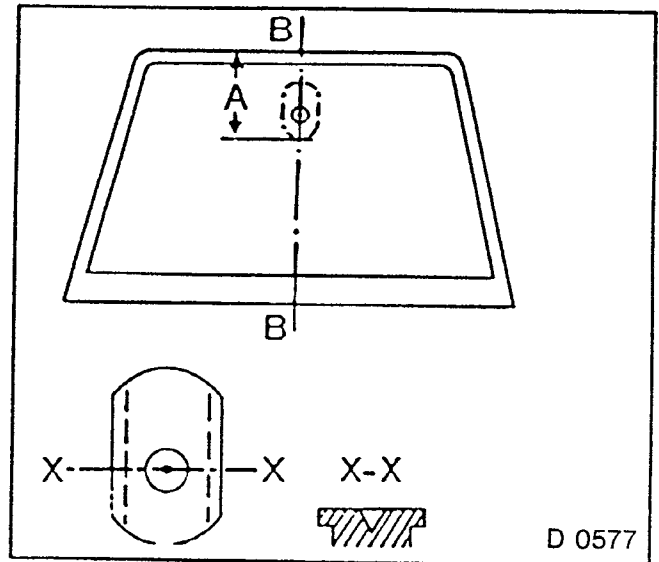


Fig 8

## Front Door Sash Window (Manual and Electric Actuation) Remove and Install

### REMOVE, DISCONNECT

1. Door inner panelling, foil, window shaft weatherstrips (outer and inner).
2. Rear window guide rail (1) — One screw underneath door lock, pull out window guide rail downwards.

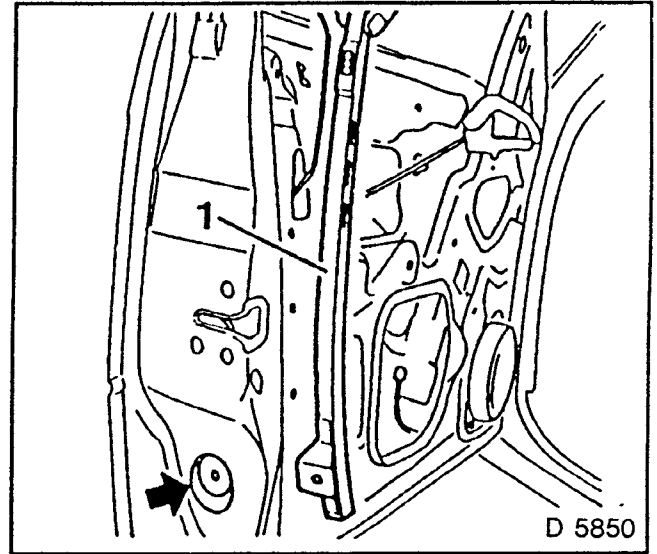


Fig 9

3. Wind window down.
- 4 Stop part (2).

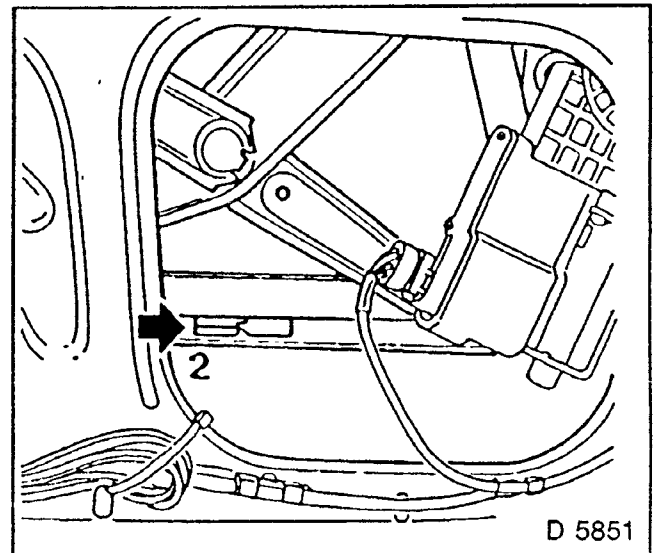


Fig. 10

### REMOVE, DISCONNECT

Scissors-type winder lower guide rail — two bolts (3).

- 1 Tilt sash window forward and pull from door channel.

### INSTALL, CONNECT

Sash window, stop part, window rear guide rail.

1. Adjust position of sash window in frame at screws (3).  
Window shaft weatherstrips, foil, door inner panelling.

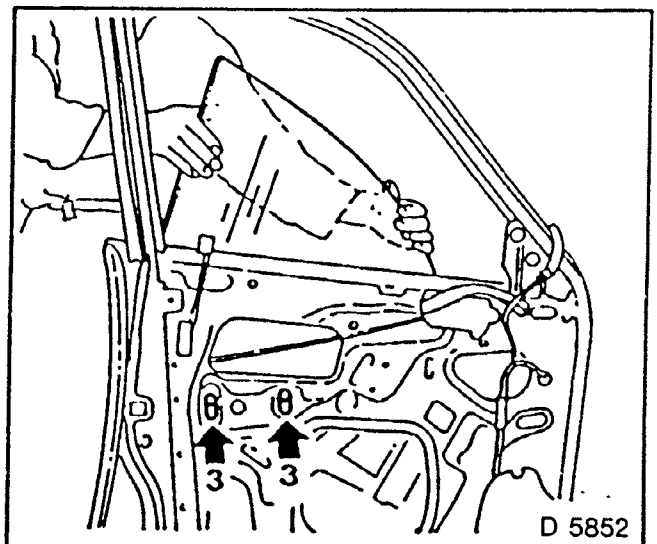


Fig. 11



## Rear Door Sash Window Remove and Install

### REMOVE, DISCONNECT

1. Door inner panelling.
2. Foil.
3. Window shaft weatherstrips (outer and inner).
4. Rear guide rail — two bolts.
5. Sash window — tilt forward and remove from shaft.

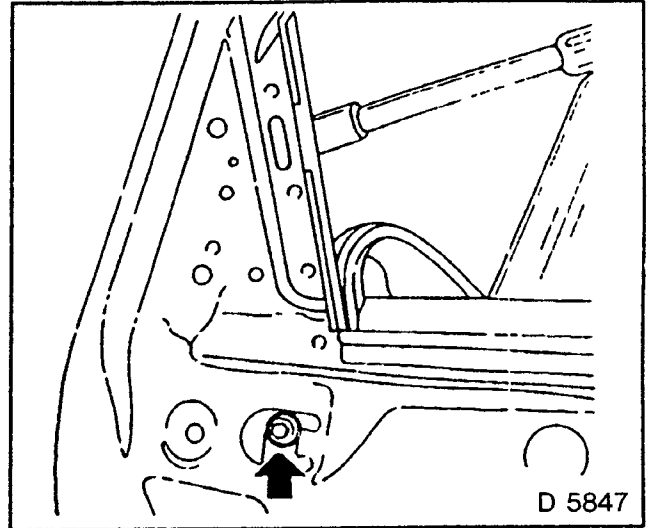


Fig. 12

### INSTALL, CONNECT

1. Sash window.
2. Rear guide rail.
3. Window shaft weatherstrips.
4. Foil.
5. Door inner panelling.

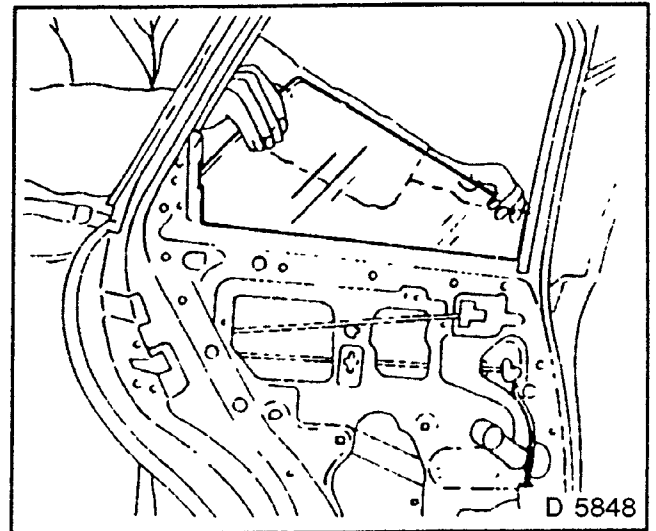


Fig 13

## Front Door Window Actuation, (Manual) — Remove and Install

### REMOVE, DISCONNECT

1. Door inner panelling.
2. Foil.
3. Wind window rail to height of upper installing hole. Secure window against slipping.
4. Drill of fastening rivets (1) and drive out.
5. Drill 8.5 mm — do not damage door panel.
6. Scissors-type winder lower guide rail — two bolts (2), window actuation.

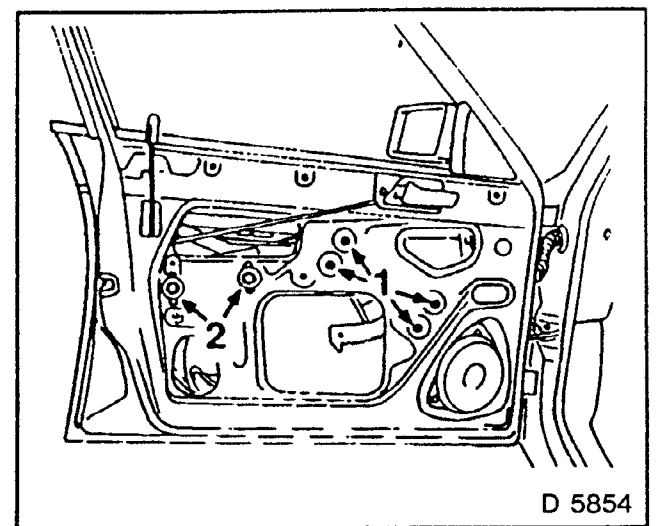


Fig 14

**INSTALL, CONNECT**

1. Window actuation — check function before installing.
2. Install lifting arms in window rail.
3. Rivet window actuation — steel blind rivets 4.8 x 11 mm.
4. Scissors-type winder lower guide rail.
5. Adjust position of sash window in frame at screws (2).
6. Foil.
7. Door inner panelling.

**Front Door Window Actuation, (Electric) — Remove and Install****REMOVE, DISCONNECT**

- 1 Disconnect wiring harness plug.
- 2 Door inner panelling.
- 3 Foil.
4. Wind window rail to height of upper installing hole. Secure window against slipping.
- 5 Drill off fastening rivets (1) and drive out.
- 6 Drill 8.5 mm — do not damage door panel.
- 7 Scissors-type winder lower guide rail — two bolts window actuation.

**INSTALL, CONNECT**

- 1 Window actuation — check function before installing.
2. Install lifting arms in window rail.
- 3 Rivet window actuation — steel blind rivets 4.8 x 11 mm.
- 4 Scissors-type winder lower guide rail.
5. Adjust position of sash window in frame at screws (2).
6. Foil.
7. Door inner panelling.
8. Wiring harness plug

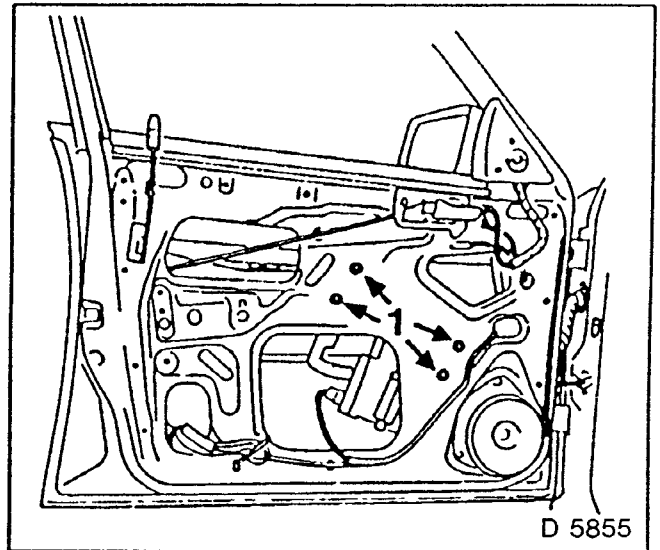


Fig. 15

## Rear Door Window Actuation — Remove and Install

### REMOVE, DISCONNECT

1. Door inner panelling.
2. Foil.
3. Window actuation.
4. Wind sash window up to centre of installing holes and secure against slipping.
5. Drill off fastening rivets (1) and drive out.
6. Drill 8.5 mm — do not damage door panel.

### INSTALL, CONNECT

- 1 Window actuation — check function before installing.
2. Insert sliding piece in window guide. Rivet window actuation — steel blind rivets 4.,8 x 11 mm.
3. Foil.
4. Door inner panelling.

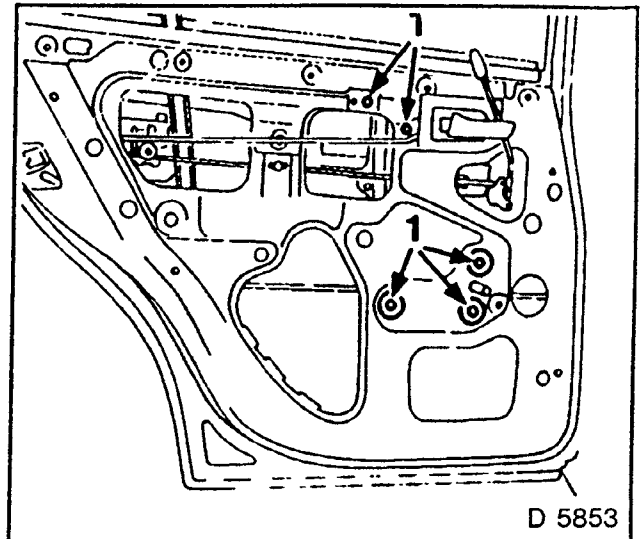


Fig 16

## Door Upper Window Guide Remove and Install

### REMOVE, DISCONNECT

Loosen window guide in stages from door window frame using wooden or plastic hammer and remove.

### INSTALL, CONNECT

1. Insert window guide at front and rear at bottom.
- 2 Starting at bottom, drive in window guide to stop in stages using rubber hammer.

### NOTE:

Ensure that profile is seated firmly.

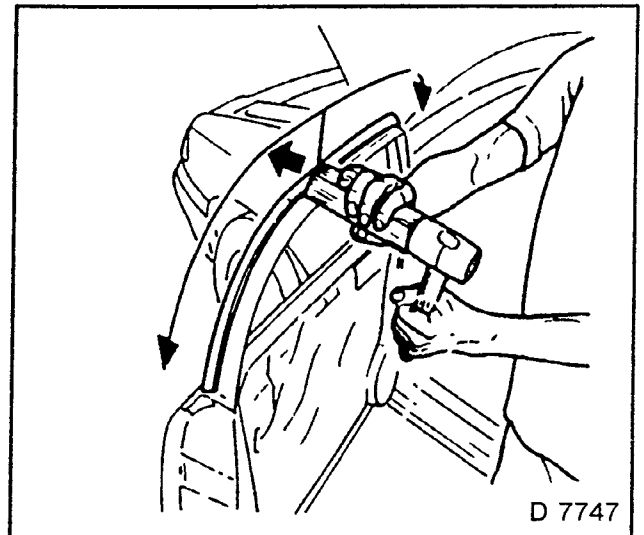


Fig 17

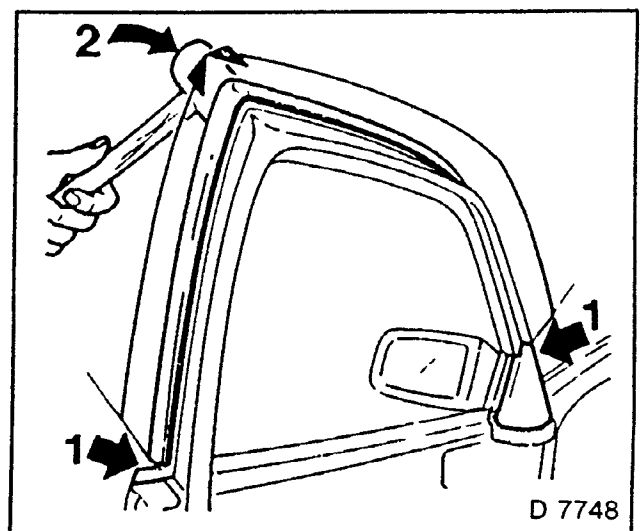


Fig. 18

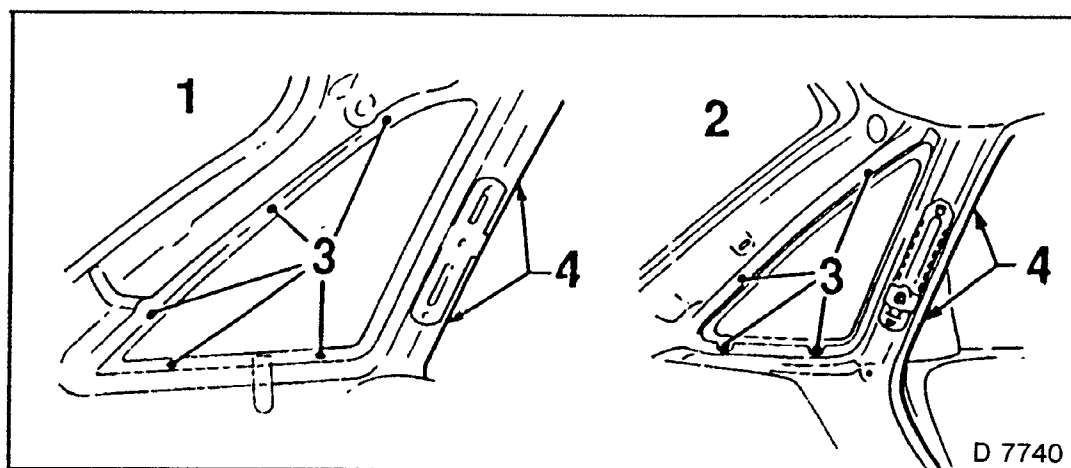


Fig. 19

## Rear Quarter Window — Remove and Install

### REMOVE, DISCONNECT

#### Panelling — Rear Quarter Window

1. (Kadett)  
Five plastic nuts (3).  
Two bolts (4).
2. (Astra)  
Four plastic nuts (3).  
Two bolts (4)

### INSTALL, CONNECT

1. Rear quarter window — use new seal, check seat of cemented seal.
2. Panelling.

**NOTE:**  
**USE NEW PLASTIC NUTS.**

## TRIM MOULDINGS, LETTERINGS, FITTINGS, HINGES

### Front Door Outer Handle — Remove and Install

#### REMOVE, DISCONNECT

1. Door inner panelling — See Section C.
2. Foil — partly loosen.
3. Detach linkage (1).
4. Two nuts (2)
5. Two retaining clips (3) on door panel.
6. Outer handle.

Where central door locking is fitted —

1. Microswitch from outer handle —
2. Remove retaining clip.

#### INSTALL, CONNECT

1. Outer handle.
2. Foil.
3. Door inner panelling.

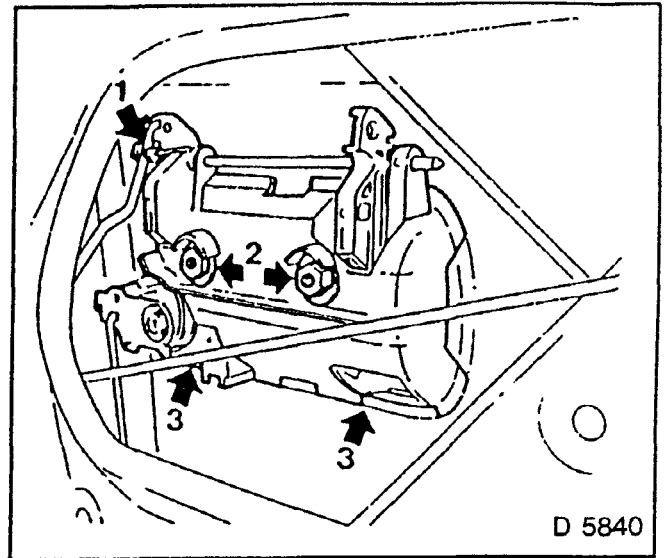


Fig 20

### Front Door Lock Cylinder — Remove and Install

#### REMOVE, DISCONNECT

- 1 Front door outer handle — See Section C

#### DISASSEMBLE

- 1 Outer handle.
2. Insert key in lock. Press off retaining ring

#### ASSEMBLE

- Outer handle
- 1 — Lock cylinder
  - 2 — Housing
  - 3 — Carrier
  - 4 — Spring
  - 5 — Ball
  - 6 — Casting
  - 7 — Retaining ring

#### INSTALL, CONNECT

- Outer handle.

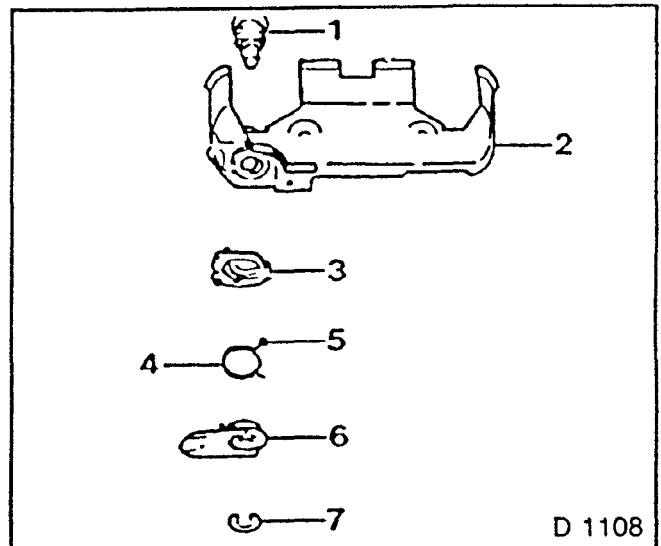


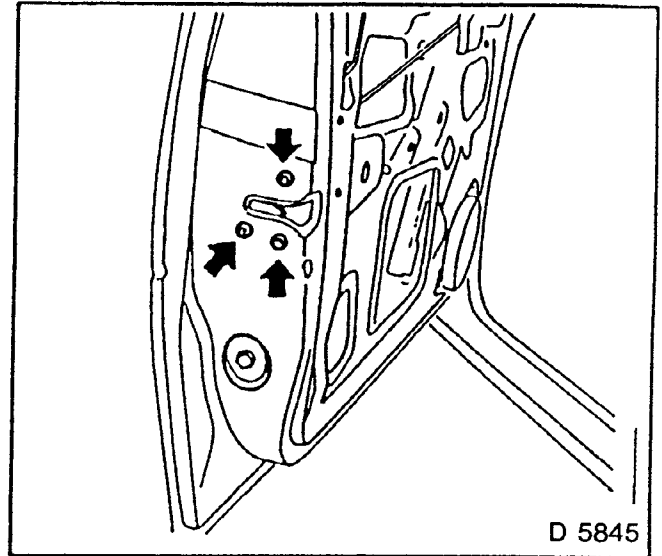
Fig 21

## Front Door Lock — Remove and Install

### REMOVE, DISCONNECT

1. Door inner panelling — See Section C.
2. Foil — partly remove.
3. Rear guide rail.
4. Detach linkage.
5. Lock — three Torx bolts —  
MKM — 604 — A

Where central door locking is fitted,  
disconnect wiring plug.

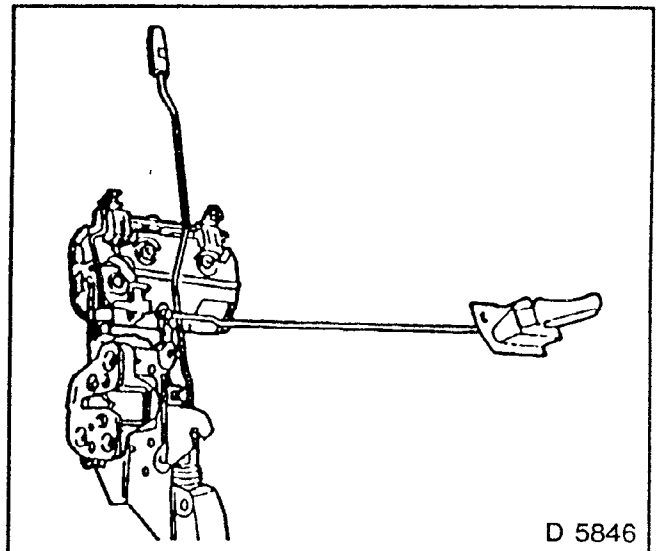


D 5845

Fig 22

### INSTALL, CONNECT

1. Lock.
2. Linkage.
3. Rear guide rail.
4. Foil
5. Door inner panelling.



D 5846

Fig 23

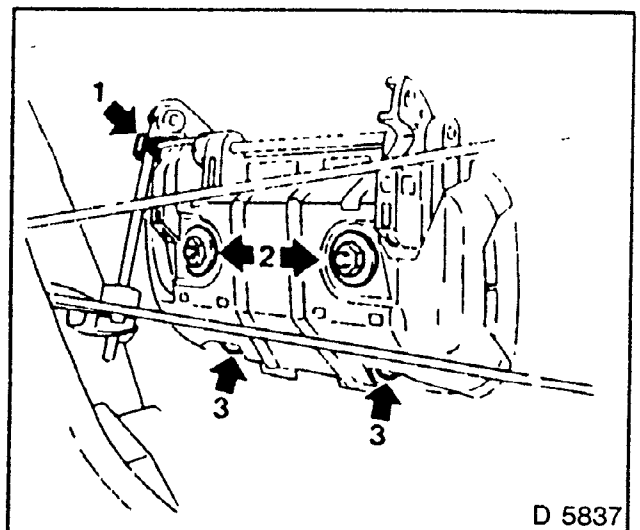
## Rear Door Outside Handle — Remove and Install

### REMOVE, DISCONNECT

1. Door inner panelling.
2. Foil — loosen partly.
3. Rear guide rail.
4. Detach linkage.
5. Two nuts (2)
6. Two retaining clips (3) on door panel.
7. Outside handle.

### INSTALL, CONNECT

1. Outside handle
2. Rear guide rail.
3. Foil.
4. Door inner panelling.



D 5837

Fig. 24

## Rear Door Lock, Remove and Install

### REMOVE, DISCONNECT

1. Door inner panelling.
2. Foil — remove partly.
3. Rear guide rail.
4. Detach linkage.
- 5 Lock — three Torx bolts — MKM — 604 — A

Where central door locking is fitted, disconnect wiring plug.

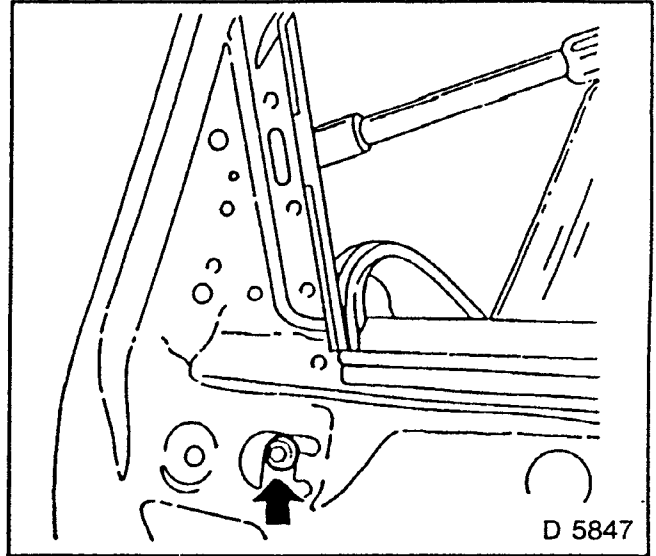


Fig. 25

### INSTALL, CONNECT

1. Lock.
2. Linkage.
3. Rear guide rail.
4. Foil.
- 5 Door inner panelling

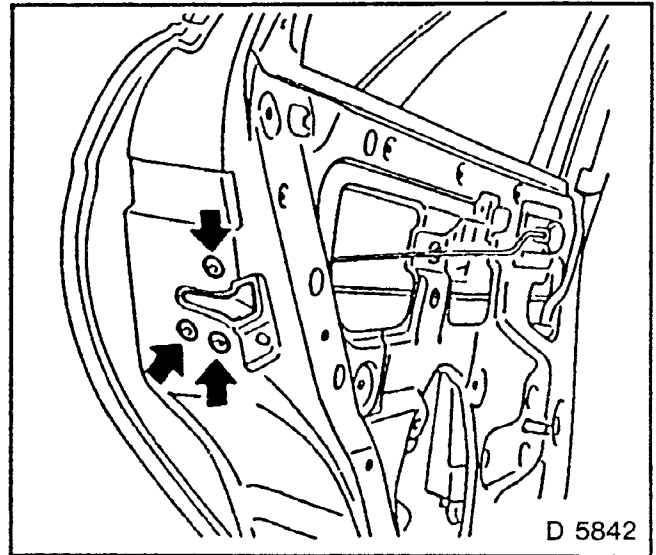


Fig. 26

## Tailgate Outside Handle (Kadett) — Remove and Install

## Luggage Compartment Lid Outside Handle (Astra) — Remove and Install

### REMOVE, DISCONNECT

1. Lower tailgate panelling (Kadett).
2. Luggage compartment lid cover (Astra).
- 3 Outside handle — two nuts

### INSTALL, CONNECT

1. Outside handle.
2. Lower tailgate panelling
3. Luggage compartment lid cover.

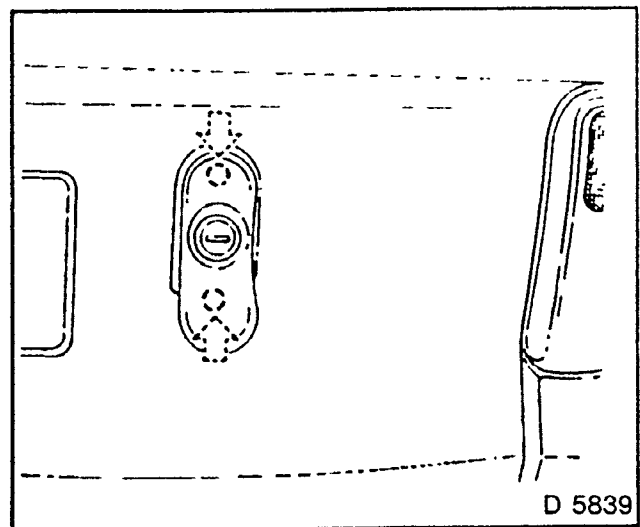


Fig. 27

## Tailgate Lock Cylinder (Kadett) — Remove and Install

## Luggage Compartment Lid Lock Cylinder (Astra) — Remove and Install

### REMOVE, DISCONNECT

1. Tailgate lower panelling (Kadett)
2. Luggage compartment cover (Astra).
3. Lock cylinder — two nuts, detach linkage.

Where central door locking is fitted,  
release microswitch and slider servo  
motor.

### INSTALL, CONNECT

1. Lock cylinder.
2. Tailgate lower panelling.
3. Luggage compartment lid cover.

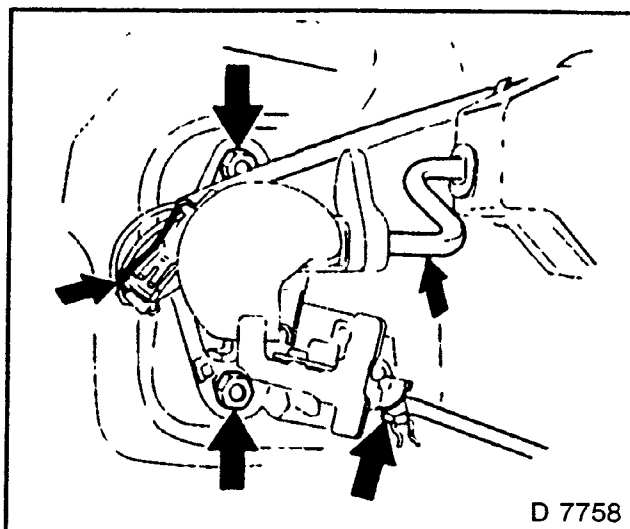


Fig 28

## Tailgate Lock — Remove and Install

### REMOVE, DISCONNECT

1. Lower tailgate panelling.
2. Detach linkage.
3. Lock

Fig. 29 — Kadett.

### INSTALL, CONNECT

1. Lock.
2. Attach linkage.
3. Lower tailgate panelling.

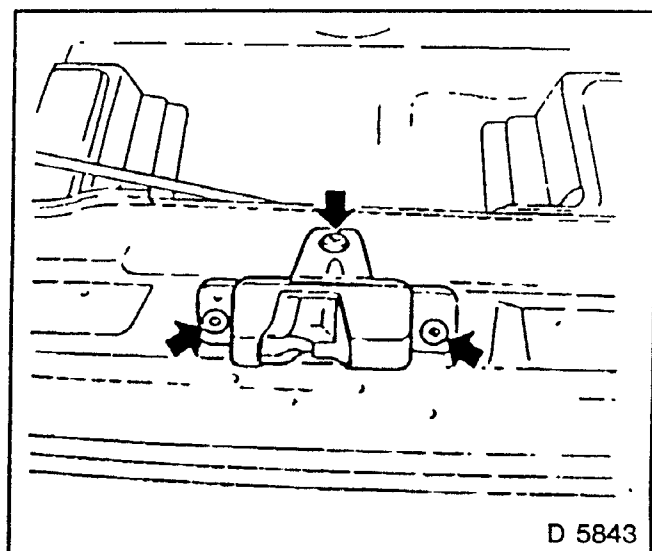


Fig 29



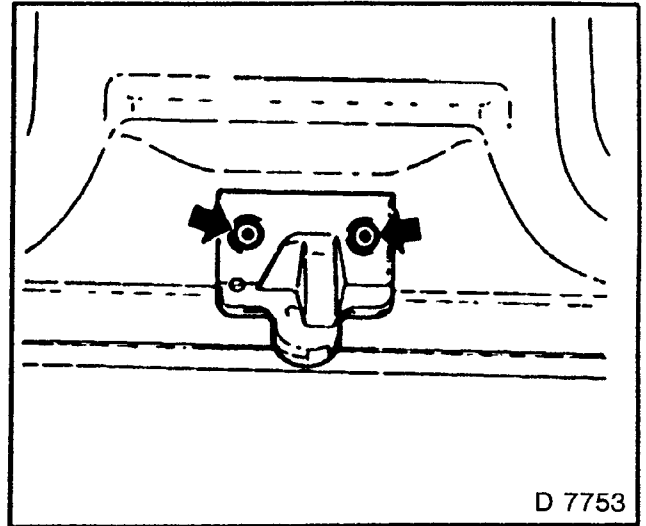
## Luggage Compartment Lock (Astra) — Remove and Install

### REMOVE, DISCONNECT

1. Lock — Two Torx bolts —  
MKM — 604 — A
2. Detach linkage.

### INSTALL, CONNECT

1. Attach linkage.
2. Lock.



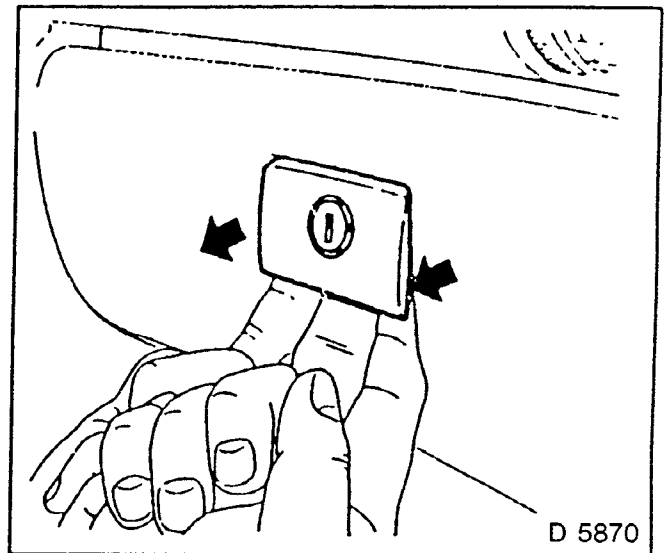
D 7753

Fig. 30

## Glove Compartment Lid Lock Cylinder — Remove and Install

### REMOVE, DISCONNECT

1. Press cover securing lugs together and remove cover.
2. Insert key in lock cylinder.
3. Turn lock cylinder in locking position and remove.

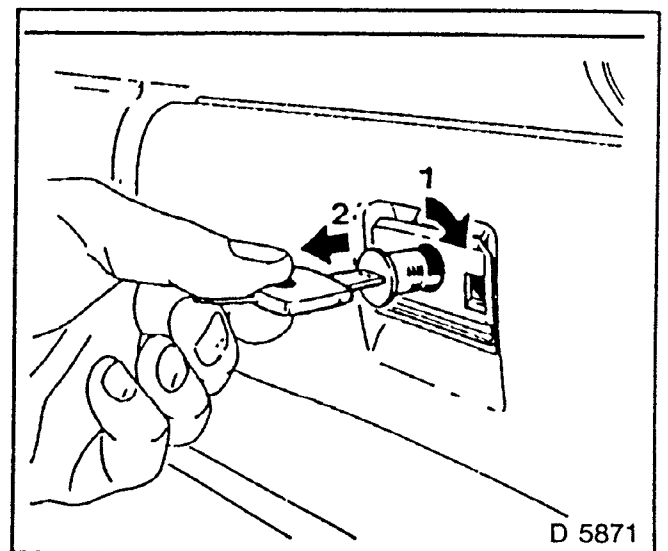


D 5870

Fig. 31

### INSTALL, CONNECT

1. Lock cylinder
2. Cover.



D 5871

Fig. 32

## Tailgate Hinge — Remove and Install

### REMOVE, DISCONNECT

1. Roof frame panelling.
2. Tailgate (second mechanic).
3. Pull out hinge bolts.
  - 1 — Hinge bolts
  - 2 — Retaining ring
  - 3 — Hinge bolt collar (points to centre of vehicle).
4. Hinge — unbolt.

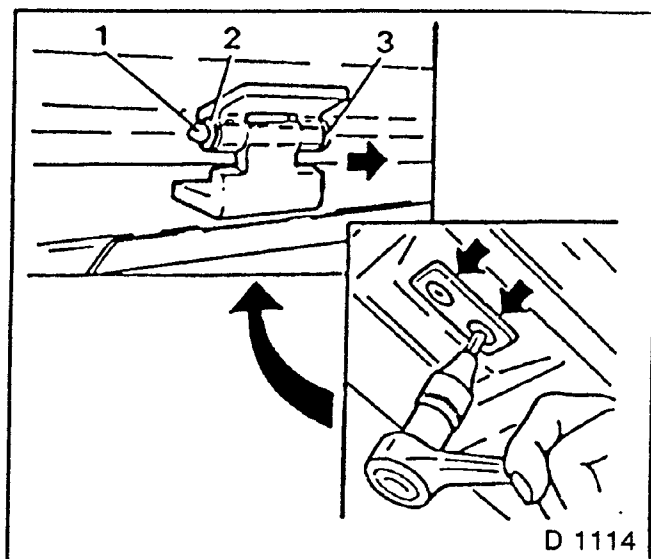


Fig. 33

### INSTALL, CONNECT

1. Hinge.
  - 1 — Hinge bolts (coat with grease)
  - 2 — Retaining ring
  - 4 — Countersunk bolt
  - 5 — Plate
  - 6 — Roof frame panel
  - 7 — Seal
  - 8 — Hinge
2. Tailgate.
3. Roof frame panelling.

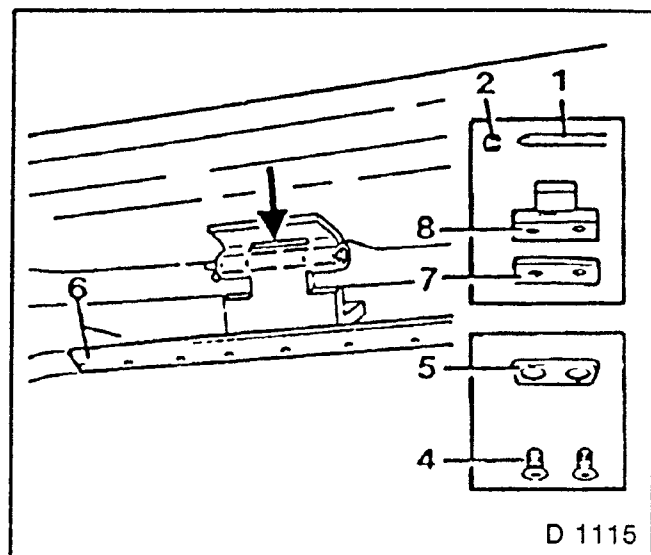


Fig. 34

## Side Protective Trim Strips — Replace

### REMOVE, DISCONNECT

1. Protective trim strips.  
Heat with hot air dryer and remove.

### WARNING:

**DO NOT OVERHEAT PAINT.**

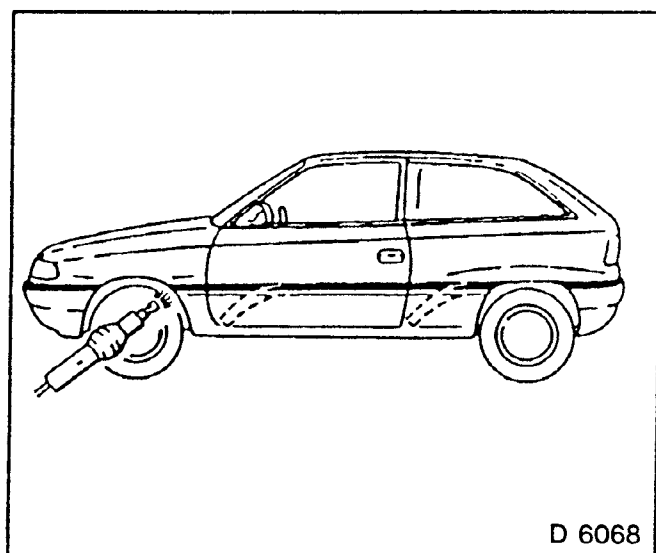
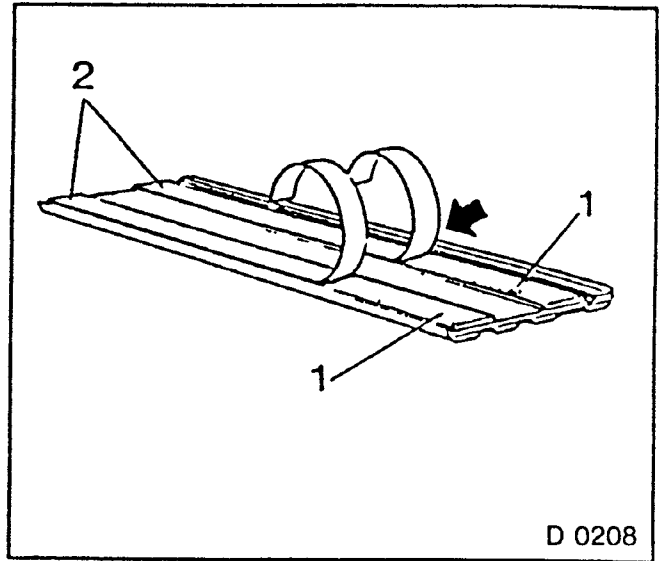


Fig. 35

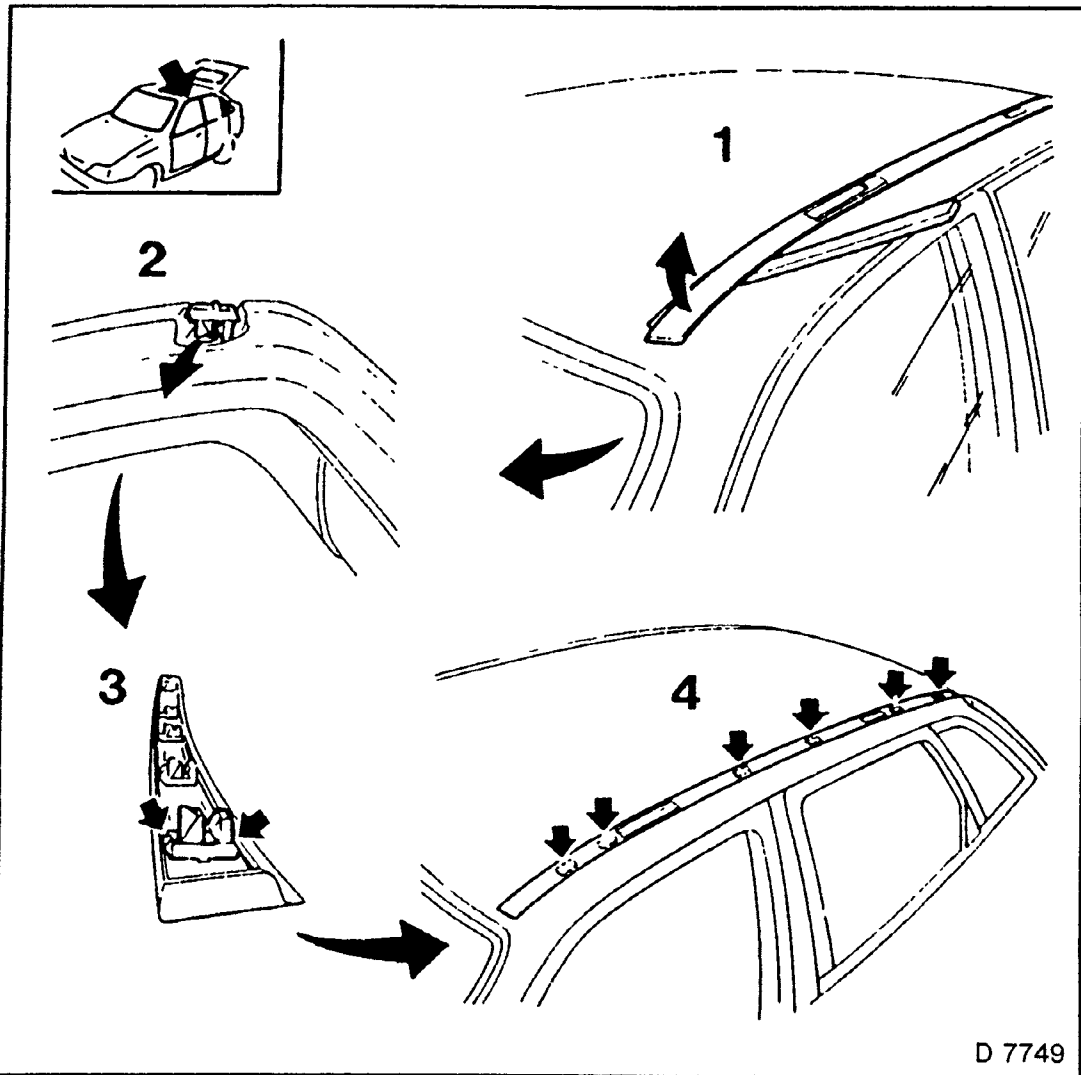
**INSTALL, CONNECT**

1. Protective trim strips.
2. Clean body cementing areas with benzine (commercially available).
3. Heat trim strips to approximately 80°C/176°F (hot air dryer, painting oven).
4. Remove protective foil.
5. Cement on trim strip.



D 0208

Fig 36



D 7749

Fig 37 2. Push out retaining clips.

**Roof Cover Strip —  
Remove and Install**

**REMOVE, DISCONNECT**

1. Lever up roof cover strip with plastic or wooden wedge.

**INSTALL, CONNECT**

3. Insert retaining clips into cover strip.
4. Press on cover strip.

## SEATS, UPHOLSTERY, INNER PANELLING

### Front Door Inner Panelling — Remove and Install

#### REMOVE, DISCONNECT

1. Window crank — KM — 317 — A
2. Door inner panelling — KM — 475 — A
3. Six bolts, nine clips (1)

Where "electric outside rear view mirror" and/or "electric window winders" is fitted, lever out switch strip.

4. Disconnect wiring plug behind door inner panelling.

#### INSTALL, CONNECT

1. Door inner panelling.
2. Window crank.

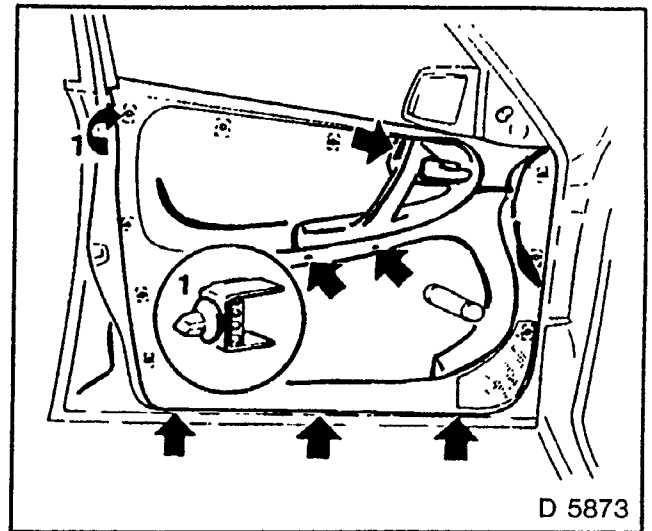


Fig. 38

### Rear Door Inner Panelling — Remove and Install

#### REMOVE, DISCONNECT

1. Door handle cover — lever off with screwdriver.
2. Window crank — KM — 317 — A
3. Door inner panelling — KM — 475 — A  
Four bolts, eleven clips (1)

#### INSTALL, CONNECT

1. Door inner panelling.
2. Window crank.
3. Door handle cover.

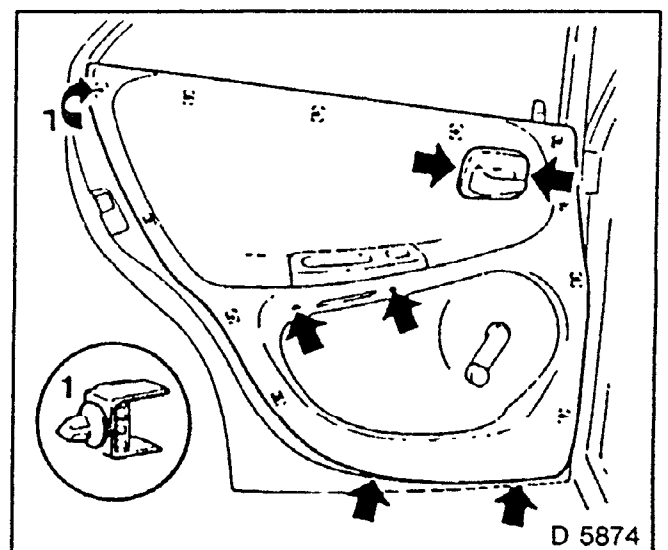


Fig. 39

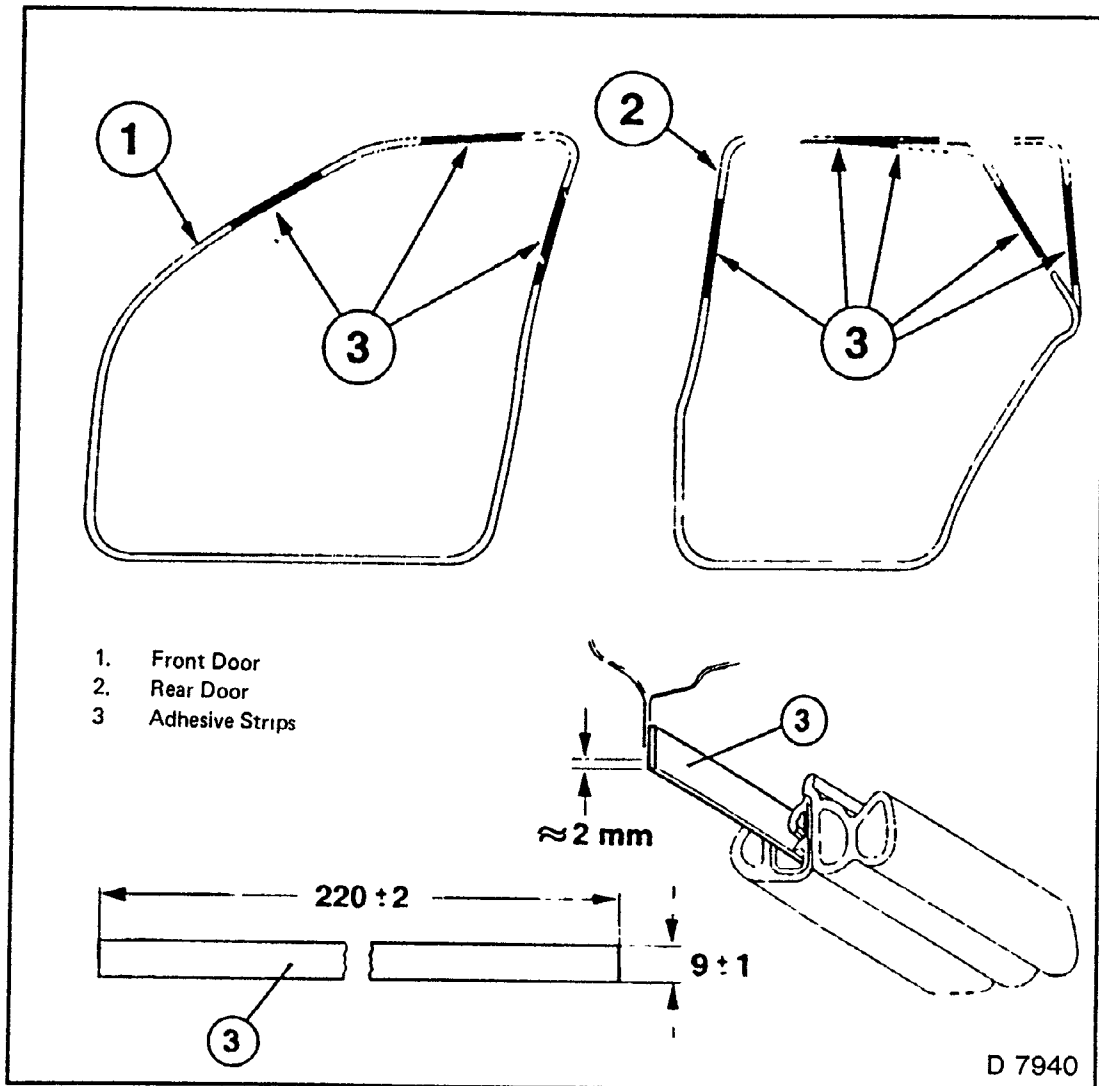


Fig 40

## Rubber Door Seal — Remove and Install or Replace

### REMOVE, DISCONNECT

1. Sill panelling
2. Pull off rubber seal
3. Remove remains of adhesive tape.
4. Clean cementing surface.

### INSTALL, CONNECT

1. Rubber seal.

### NOTE:

1. Completely removed rubber seals may not be re-used
2. Only partially removed rubber seals may be used.
  - a) Cement adhesive strips — 220 mm long — to body flange at  $+ 23^{\circ}\text{C}/73^{\circ}\text{F} \pm 5^{\circ}\text{C}/10^{\circ}\text{F}$  at least 15 minutes before installation of rubber seal.
  - b) Remove protective foil.
  - c) Install rubber seal.
  - d) Install sill panelling.
3. Always use new double-sided adhesive tape.

## Sill Panelling Seal — Remove and Install

### REMOVE, DISCONNECT

1. Lever off seal from welding pins.

### INSTALL, CONNECT

1. Seal.

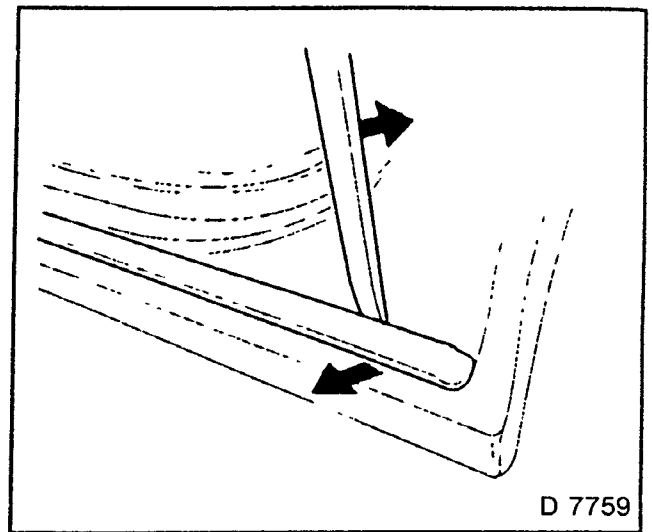


Fig. 41

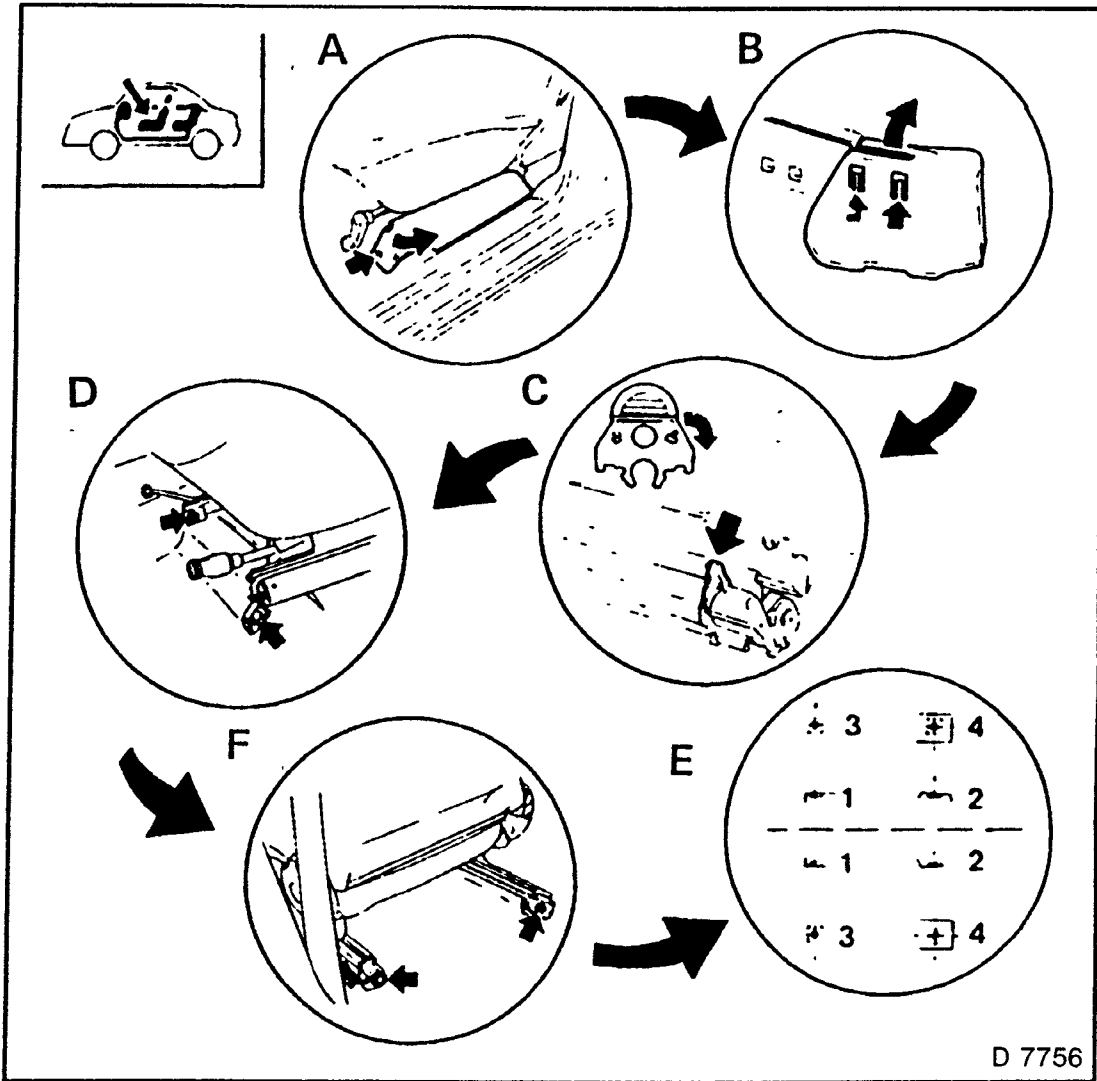


Fig 42

## Front Seat — Remove and Install

### REMOVE, DISCONNECT

- 1 Front outer cover.  
One bolt and remove backwards (A).
- 2 Rear inner cover.  
Two retaining lugs (B).

### CAUTION:

- 3 Before removing seat, always insert securing fork on the energy store into the special opening in the seat belt tensioner (C).
4. Remove front seat.
  - 4.1 Two bolts at front (D).
  - 4.2 Two bolts at rear (E).

### INSTALL, CONNECT

- 1 Front seat

### Tighten Torque

Bolts to underbody — 20 Nm  
Observe order 1 to 4 (f).  
Use new bolts

2. Remove securing fork.
3. Front and rear covers.

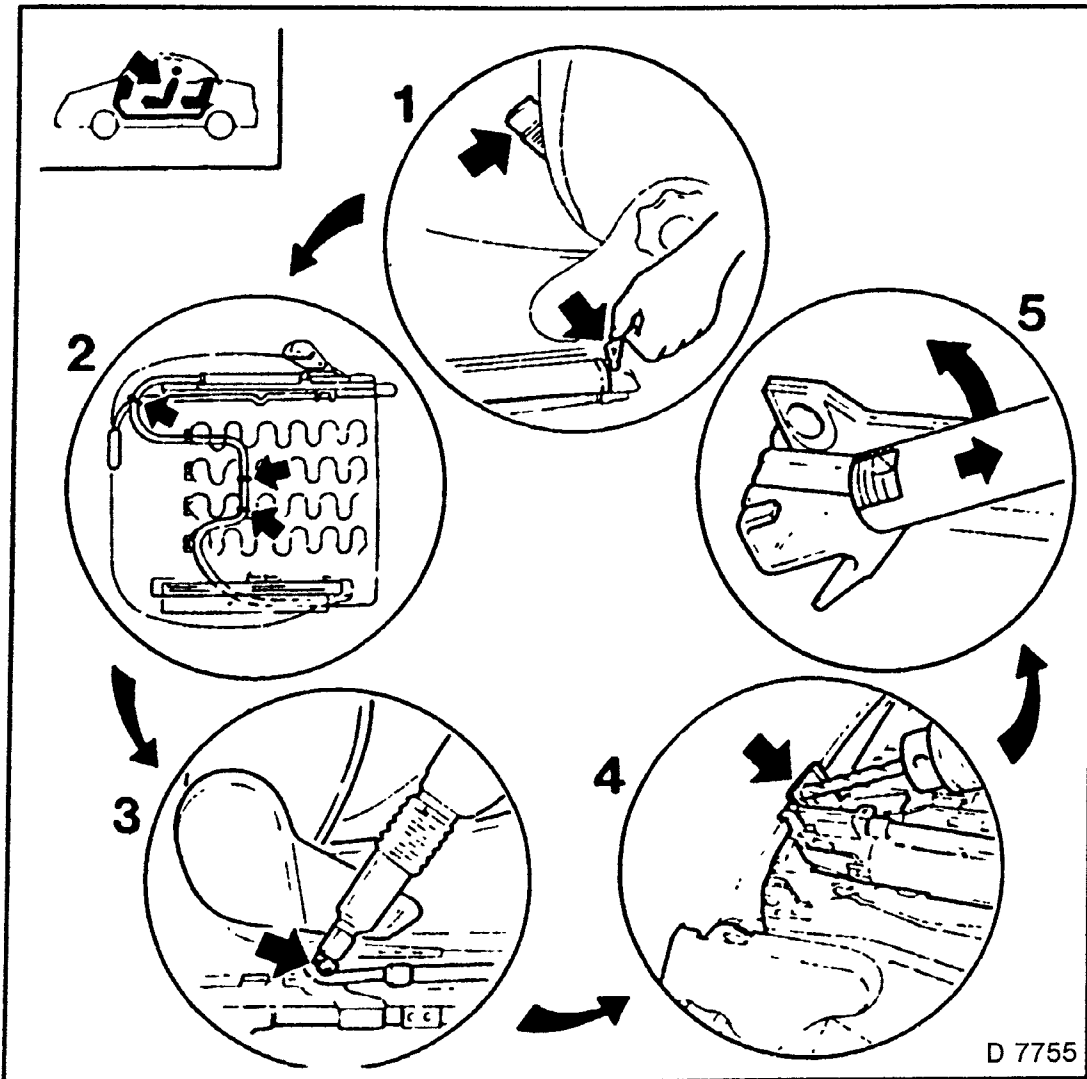


Fig 43

## Belt Lock Tensioner — Remove and Install or Replace

### REMOVE, DISCONNECT

- 1 With non-triggered belt lock tensioner (no yellow trigger display visible on lock) retaining fork fastened to kinetic energy store must be tightly inserted into special opening.

### NOTE:

- a) **INSERTED RETAINING FORK MUST BE ABLE TO BE PUSHED IN UP TO THE PIPE.**
- b) **BOTH RETAINING FORK SECURING LUGS MUST REST FIRMLY ON PIPE. IF NOT, TRIGGER BELT LOCK TENSIONER INTENTIONALLY IMMEDIATELY. TRIGGER**

**INTENTIONALLY BY BLOW OF HAMMER ON KINETIC ENERGY STORE (FRONT) WITH RETAINING FORK REMOVED.**

- c) **YELLOW TRIGGER WILL BE DISPLAYED ON BELT LOCK.**

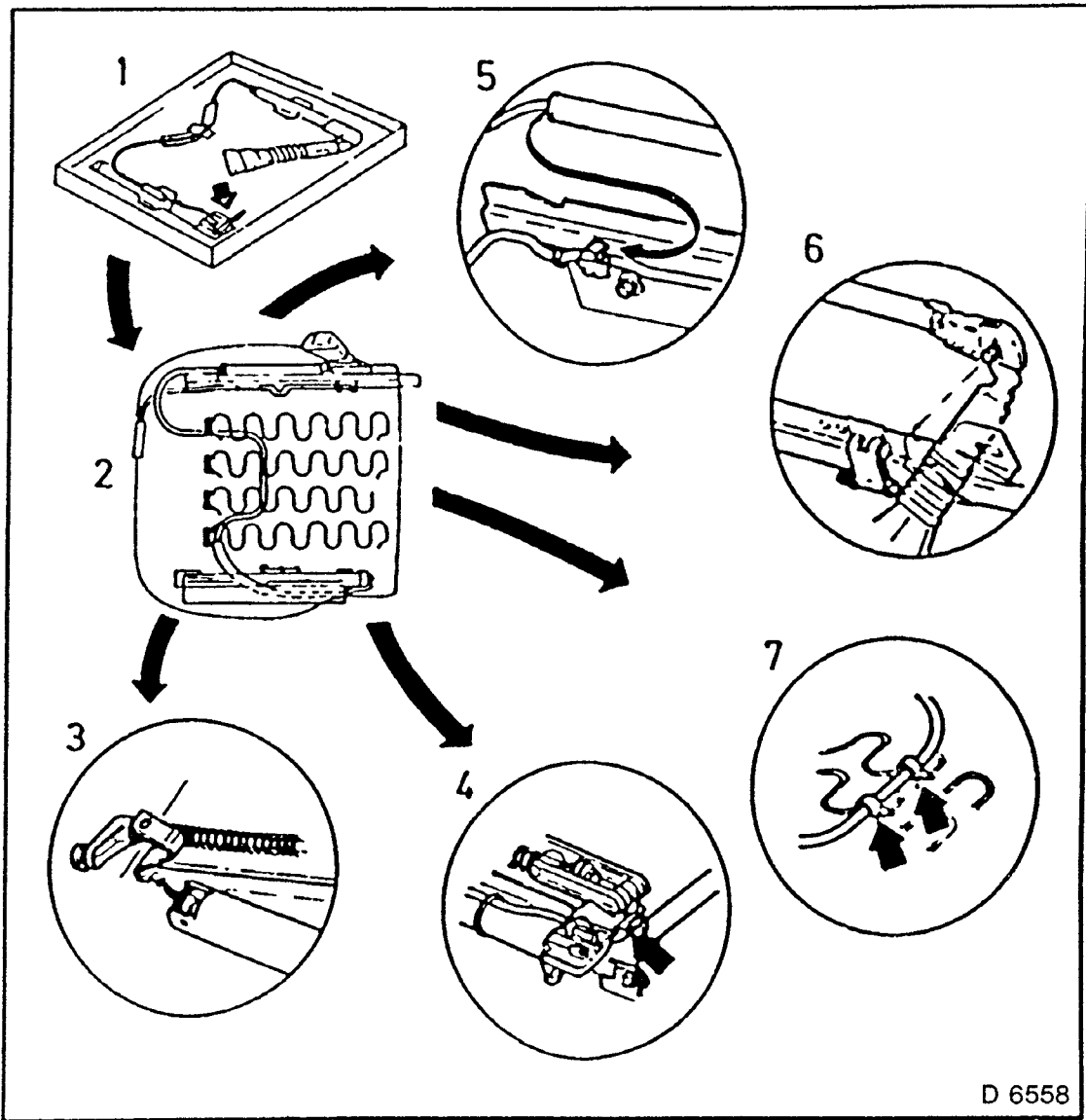
Front seat

2. Unclip bowden cable.
3. Unbolt belt lock
4. Drill out kinetic energy store fastening rivet.
5. Pull kinetic energy store from retaining drift.

### CAUTION:

**PROTECT BELT LOCK TENSIONER FROM VIBRATION AND ON NO ACCOUNT DISASSEMBLE (PRESSURE SPRING).**





D 6558

Fig 44

**INSTALL, CONNECT**

1. Check proper seating of retaining fork.  
Remove belt lock tensioner from packing.
2. Installation position on seat
3. Insert kinetic energy store into retaining drift
4. Bolt on kinetic energy store fastening clip
5. Push sleeve into retaining clip.
- 6 Bolt on lock.

**TIGHTEN (TORQUE)**

Belt lock tensioner to front seat —  
35 Nm

7. Attach Bowden cable with cable clips to seat springs at points marked with colour.
8. Install front seat.

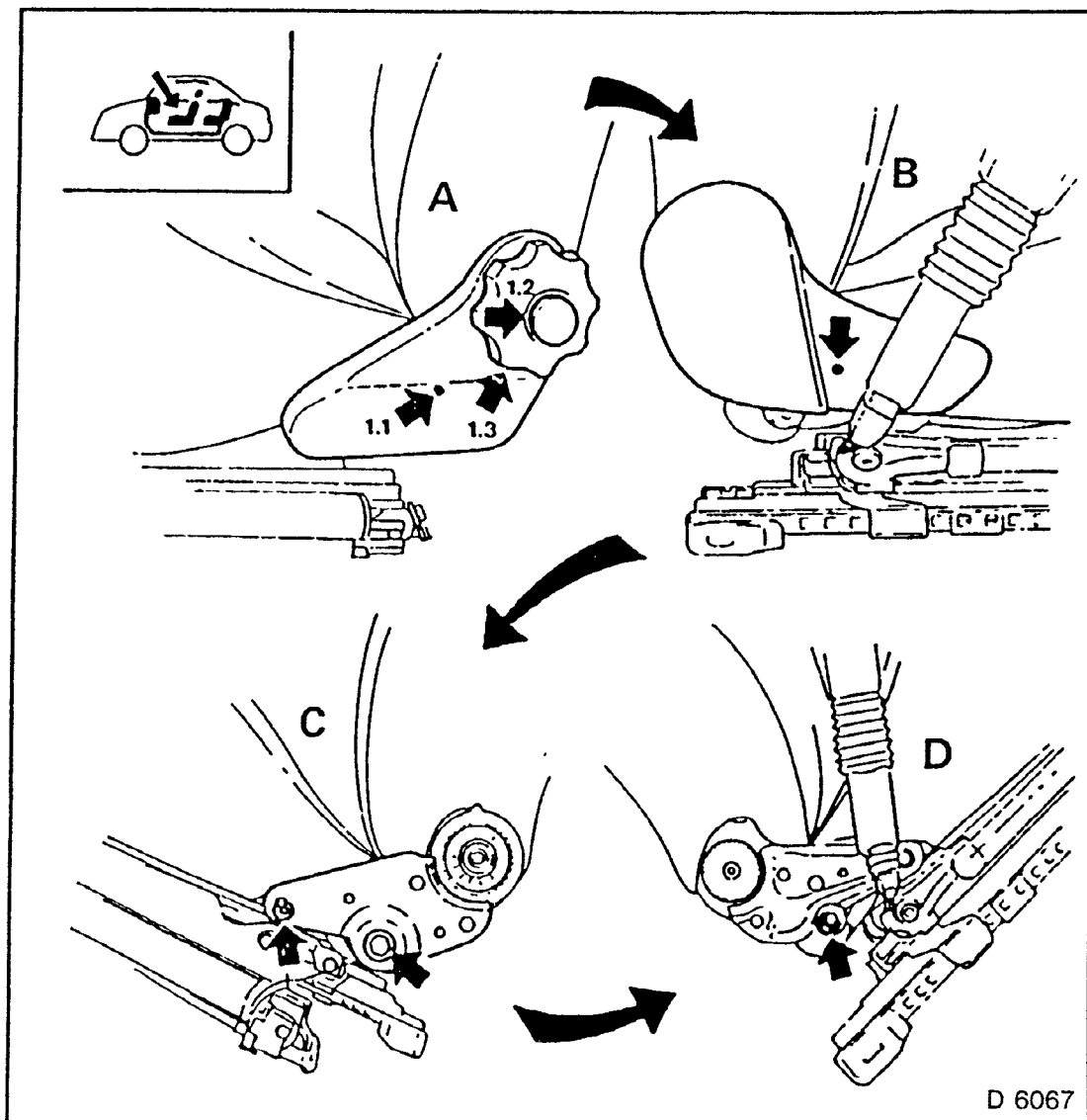


Fig 45

## Front Seat Backrests — Remove and Install

### REMOVE, DISCONNECT

- 1 Front seat.
  - A) Outer cover.
    - 1.1 Body-bound rivet pin
    - 1.2 Lever out plugs.
    - 1.3 Remove adjustment wheel
  - B) Inner cover.
    - Body-bound rivet pin.
  - C) Outside
    - Bolt, safety fitting.
  - D) Inside.
    - Safety fitting.
- 2 Front seat backrests.

### INSTALL, CONNECT

1. Front seat backrests.
- 2 Inner and outer covers.
3. Front seat.

**NOTE:**  
**PROTECT SEAT REMOVED ON  
 ACCOUNT OF SEAT LOCK  
 TENSIONER FROM VIBRATIONS.**

## Rear Seat — Remove and Install

### REMOVE, DISCONNECT

1. Lift up rear seat.
2. Unclip cover.
3. Lock washers.
4. Hinge pins.
5. Rear seat.

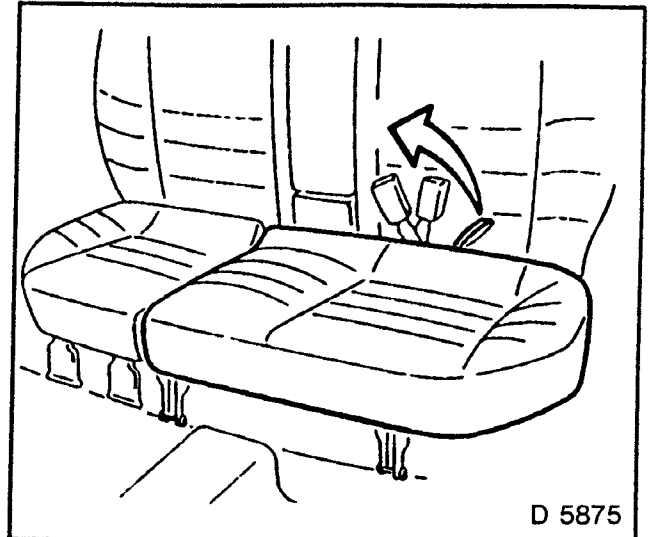


Fig 46

### INSTALL

1. Rear seat
2. Hinge pins
3. Lock washers
4. Cover

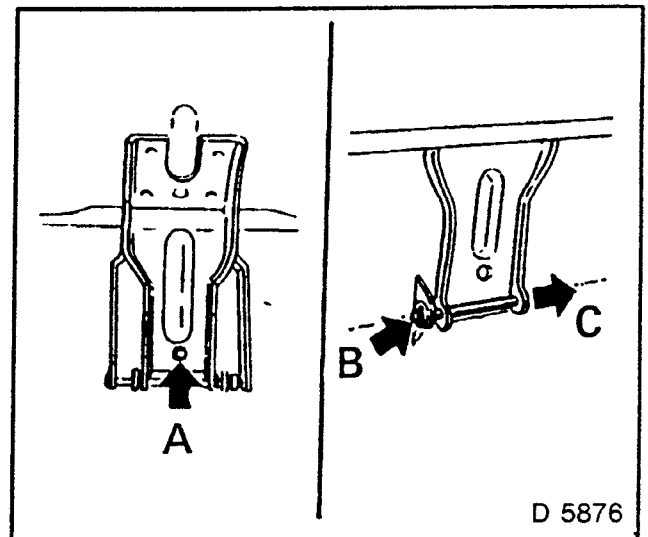


Fig 47

## Rear Seat Backrest — Remove and Install

### REMOVE, DISCONNECT

1. Fold rear seat backrest forward
2. Detach corners of carpet — KM — 569 — A (1).
3. Unbolt rear seat backrest (2) — Two bolts each.

### INSTALL

1. Rear seat backrest
2. Carpet

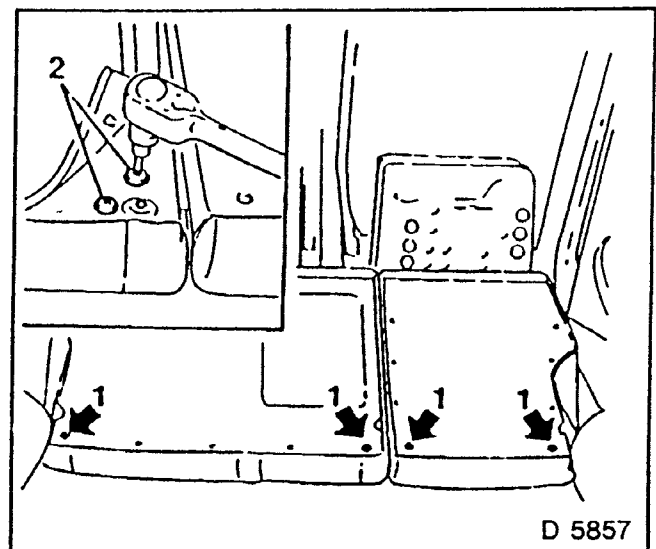


Fig. 48

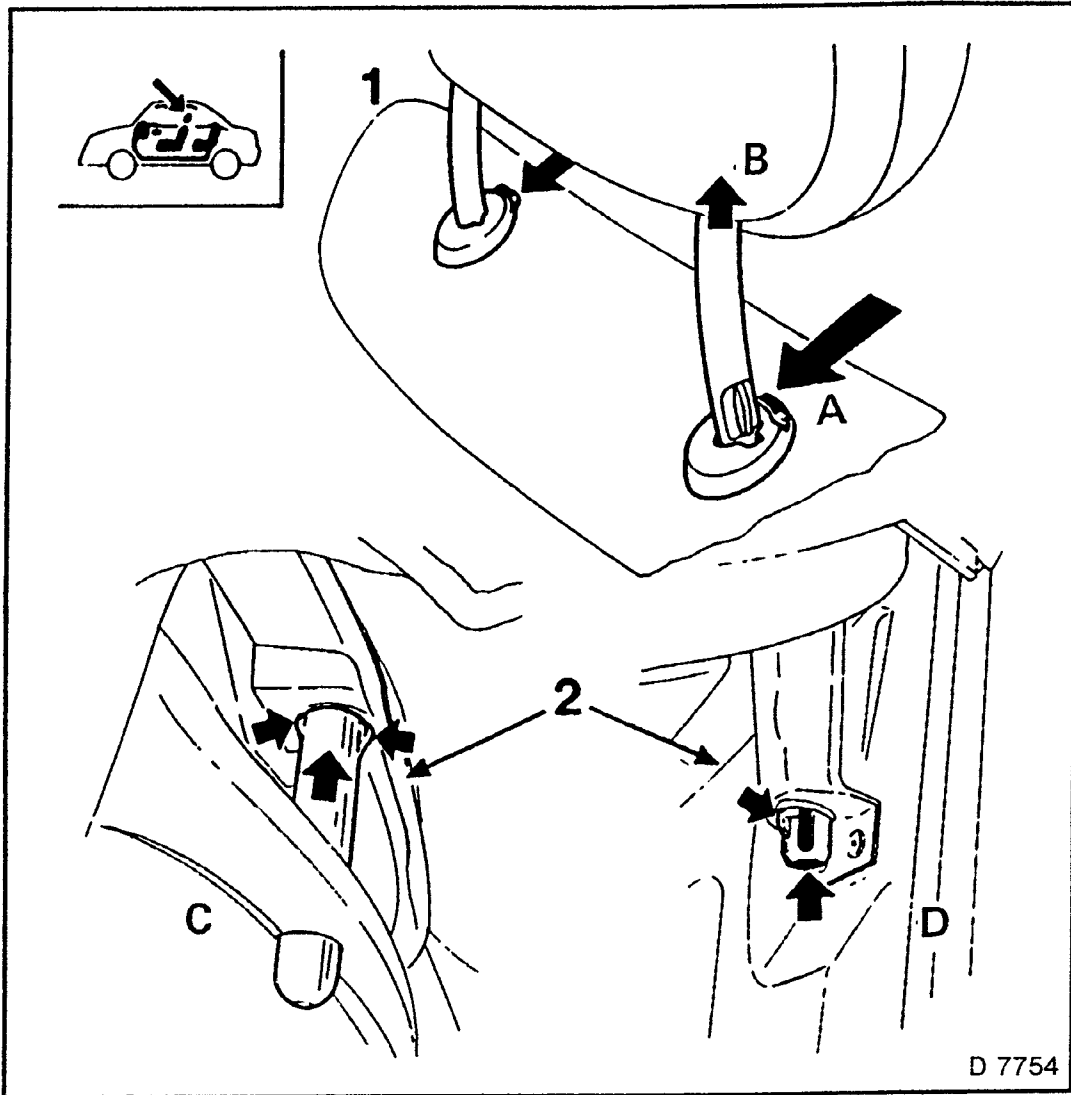


Fig 49

## Headrest Guide Sleeve — Remove and Install

### REMOVE, DISCONNECT

Front seat backrest or rear seat backrest

1. Headrest
  - A) Release two retaining springs
  - B) Pull out headrest upwards

Unstitch upholstery; ring clamps may not be removed.

2. Guide sleeve
    - Press in retaining lugs,
    - Remove guide sleeve
- C) Front seat  
D) Back seat

### INSTALL

1. Upholstery
2. Insert guide sleeve and engage
3. Headrest
4. Front seat backrest or rear seat backrest

## Rear Seat Headrest — Service Install

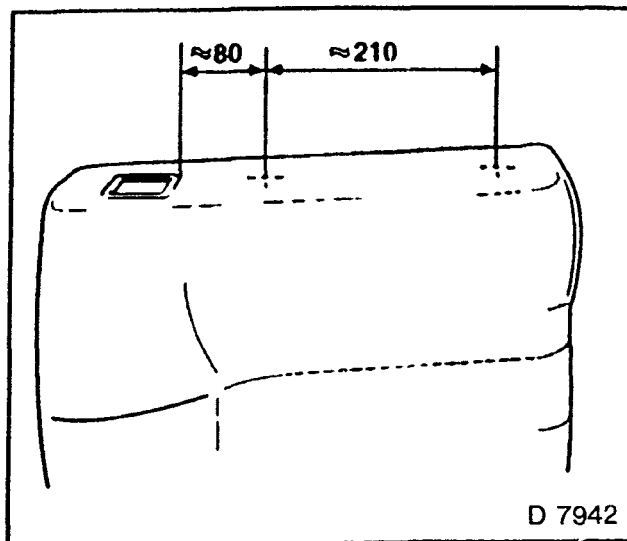
### REMOVE, DISCONNECT

1. Rear seat backrest.
2. Upholstery.
3. Replace backrest with version with rivetted brackets.

Do not install brackets into backrests to accommodate headrests. Only install headrests where brackets have been fitted.

### INSTALL, CONNECT

1. Upholstery
2. Locate holes under upholstery by probing with finger and cut small cross into upholstery.
3. Press in headrest guide sleeves.
4. Install headrest.
5. Rear seat backrest.



D 7942

Fig. 50

## Upholstery Cover for Front Seat — Remove and Install or Replace

### REMOVE, DISCONNECT

#### Front Seat:

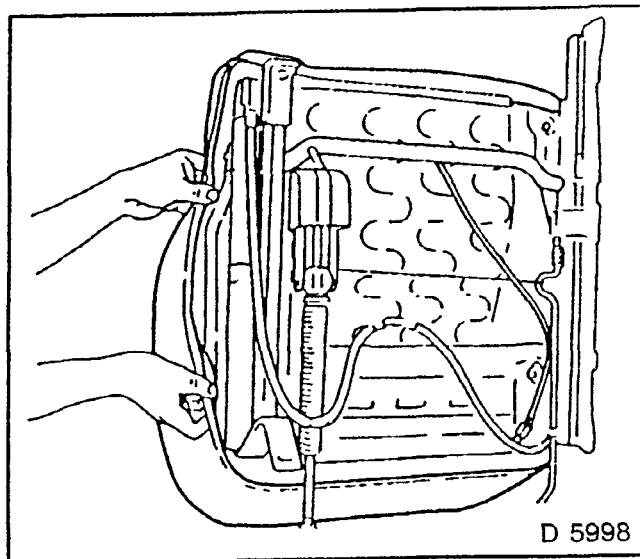
1. Before removing the front seat, the retaining fork fastened to the seat must be inserted into the special opening on belt lock tensioner. (if fitted).

#### Front seat backrests:

2. Disconnect wiring harness plug for seat heating (if present).
3. Loosen upholstery cover from underneath.

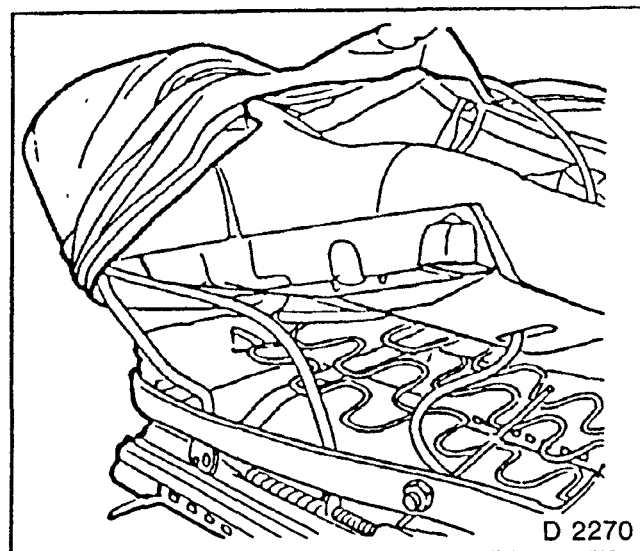
**NOTE:**  
**INSERT LOCKING PLATE INTO PRE-TENSIONER BEFORE REMOVING SEAT. THIS PLATE WILL PROTECT THE BELT LOCK TENSIONER FROM VIBRATIONS WHICH COULD TRIGGER THE BELT LOCK TENSIONER.**

4. Upholstery cover with upholstery from seat frame.



D 5998

Fig 51



D 2270

Fig 52

**REMOVE, DISCONNECT**

1. Seat area circlips.
2. Upholstery cover from upholstery.

**INSTALL, CONNECT**

1. Upholstery cover on upholstery.
2. Seat area circlips.
3. Fasten upholstery cover below.
4. Front seat backrest on front seat.
5. Connect wiring harness plug for seat heating (if present).
6. Front seat.

**NOTE:**  
**ENSURE THAT THE WIRING IS LAID CORRECTLY.**

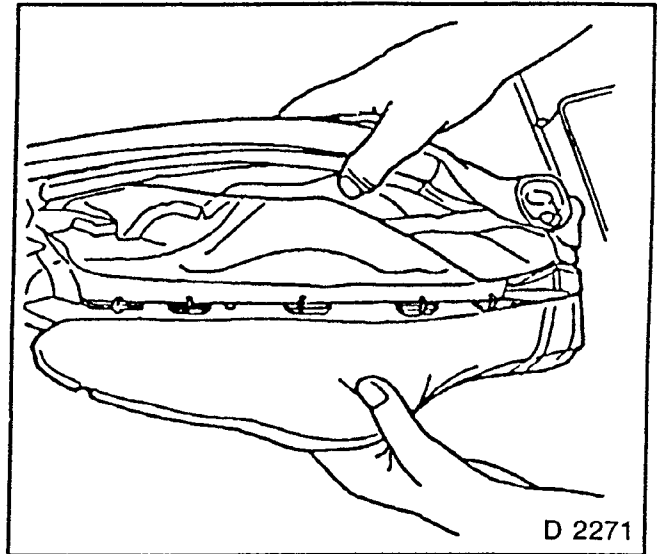


Fig. 53

## Upholstery Cover for Front Seat Backrest —

### Remove and Install or Replace

**REMOVE, DISCONNECT****Front seat and backrest —**

1. Wiring harness plug for seat heating (if present)
2. Headrest.
3. Detach upholstery cover underneath
4. Circlips.
5. Sleeves for headrest.
6. Upholstery cover

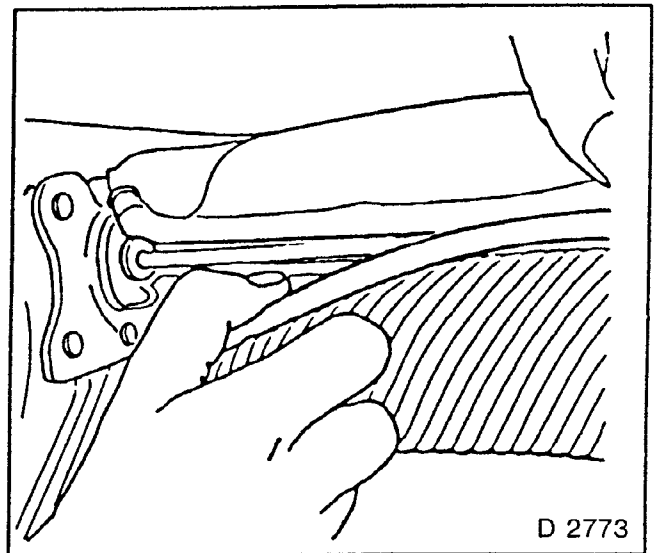


Fig. 54

**INSTALL, CONNECT**

1. Upholstery cover.
2. Circlips.
3. Hook in upholstery cover underneath.
4. Sleeves for headrest, front seat backrest on front seat.
5. Wiring harness plug for seat heating.
6. Front seat
7. Headrest.

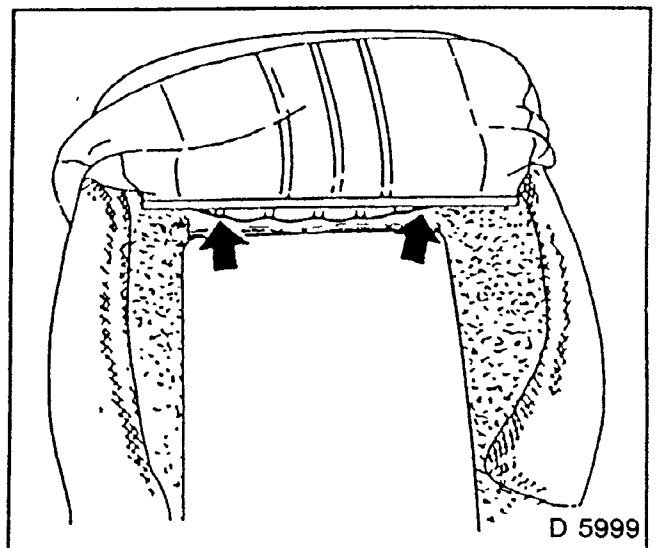


Fig. 55

## Upholstery Cover for Rear Seat —

### Remove and Install or Replace

#### REMOVE, DISCONNECT

Rear seat —

1. Loosen upholstery cover from underneath.
2. Seat area circlips (1).
3. Upholstery cover.

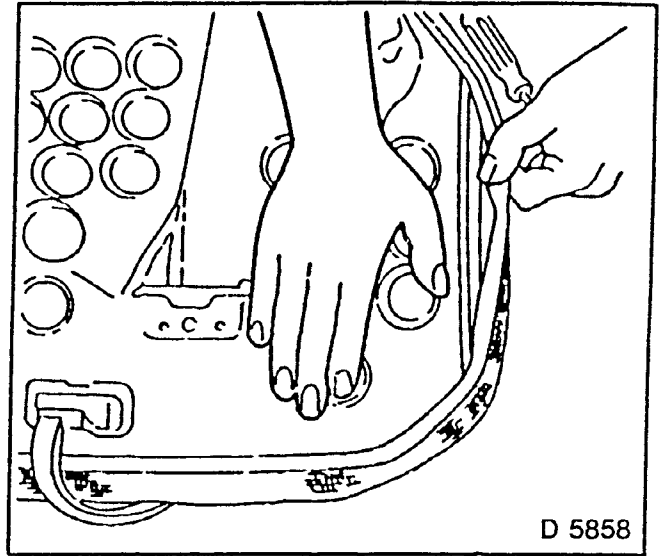


Fig. 56

#### INSTALL, CONNECT

1. Upholstery cover.
2. Seat area circlips.
3. Install upholstery cover underneath
4. Rear seat.

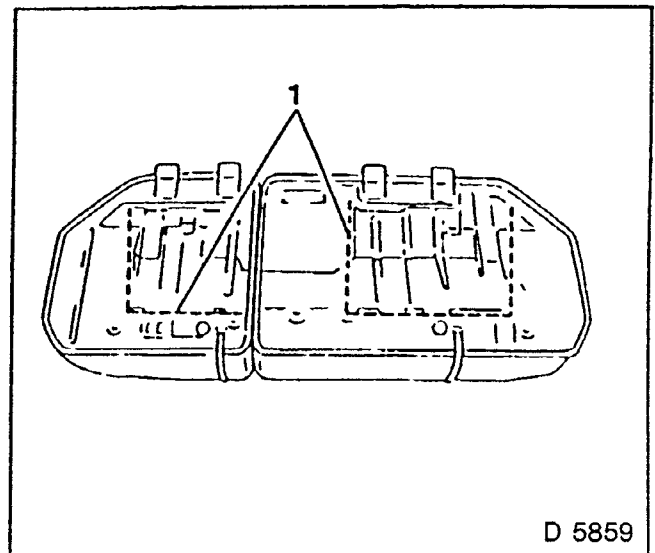


Fig. 57

## Upholstery Cover for Rear Seat Backrest —

### Remove and Install or Replace

#### REMOVE, DISCONNECT

Rear seat backrest—

1. Panelling from reverse side —  
KM — 569 — A
2. Loosen upholstery cover all round.
3. Circlips (1).
4. Upholstery cover.

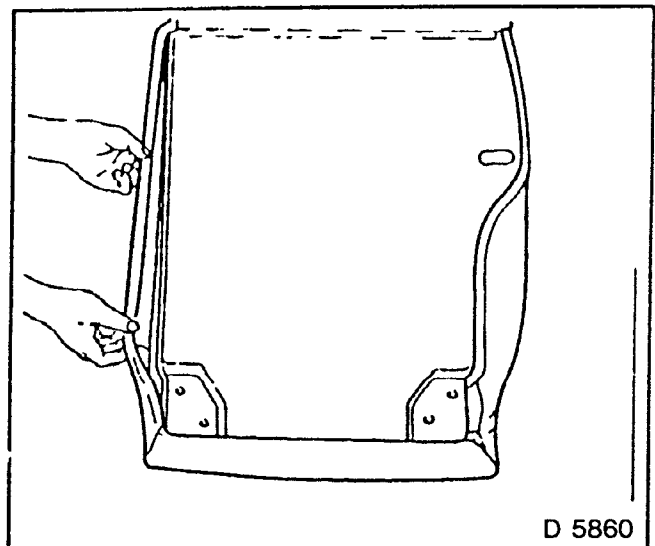


Fig. 58

**INSTALL, CONNECT**

1. Upholstery cover.
2. Circlips.
3. Install upholstery cover all round.
4. Rear seat backrest.

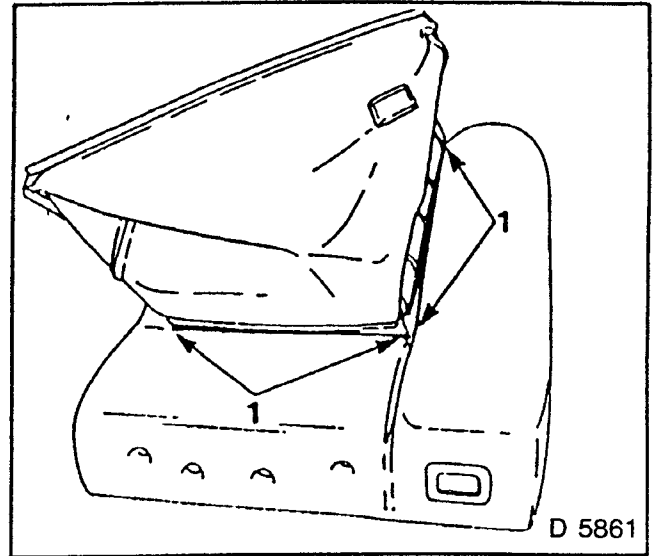


Fig 59

D 5861

## Upholstery Cover for Armrest (Where fitted) — Remove and Install or Replace

**REMOVE, DISCONNECT**

1. Armrest.
2. Open zip.
3. Upholstery cover from core part.

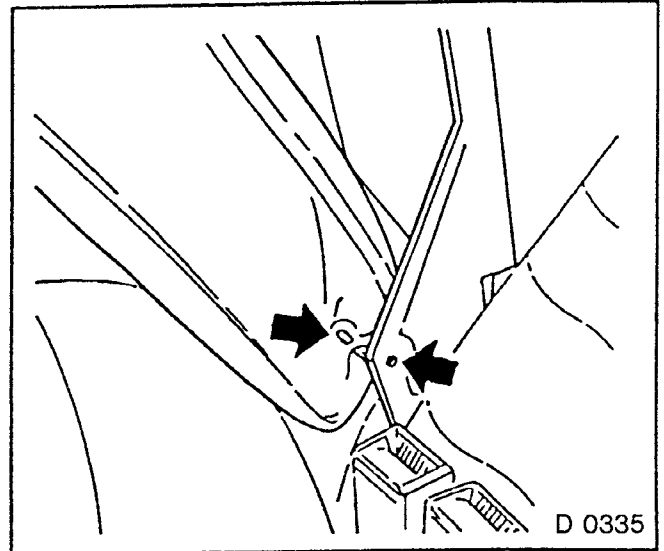


Fig 60

D 0335

**INSTALL, CONNECT**

1. Upholstery cover on core part.
2. Close zip with Mounting Set — KM — 643.
3. Secure zip ends — commercially available staples.
4. Armrest.

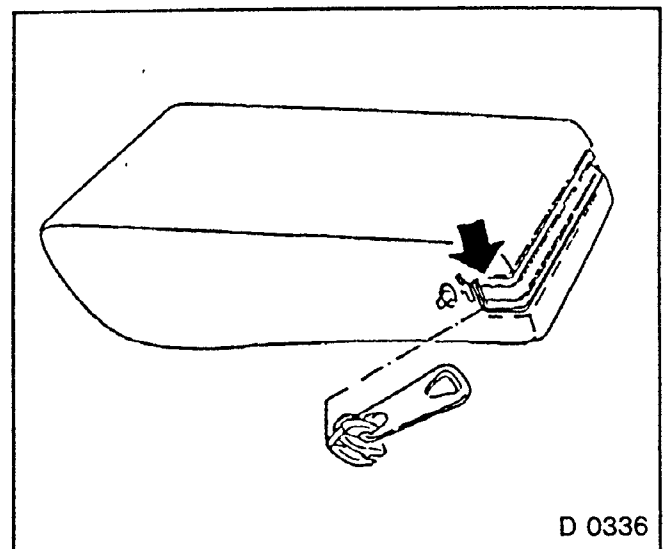


Fig 61

D 0336



## Moulded Headlining — Remove and Install or Replace

### REMOVE, DISCONNECT

1. A pillar upper panelling.
2. B pillar panelling.
3. C/D pillar panelling.
4. Rear roof frame panelling.
5. Sun visor (A).
6. Bracket (B)
7. Unclip interior lamp (C).

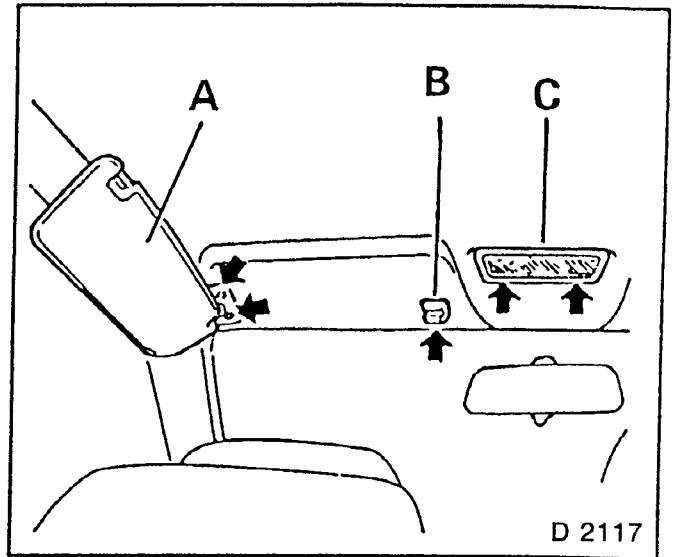


Fig 62

8. Assist handle (D) (where fitted).
9. Remove upper door weatherstrip (E).
10. Moulded headlining.

### INSTALL, CONNECT

1. Moulded headlining
2. Interior lamp.
3. Sun visor.
4. Bracket.
5. Assist handles
6. Door weatherstrips.
7. A pillar upper panelling.
8. B pillar panelling.
9. C/D pillar panelling.
10. Rear roof frame panelling.

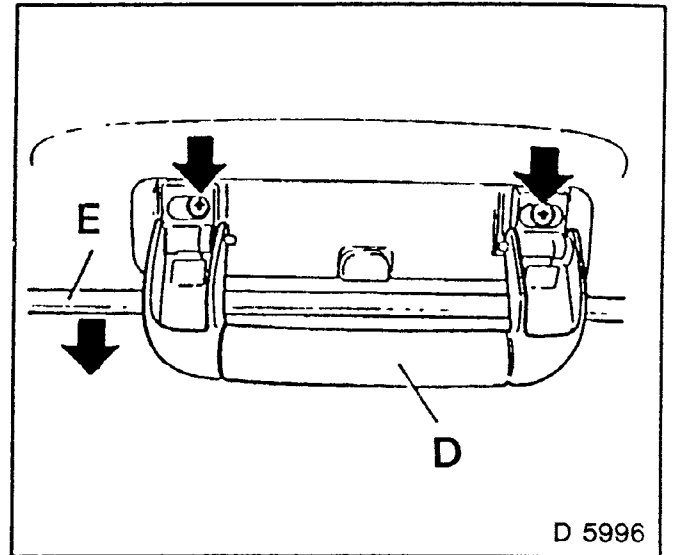


Fig. 63

## Instrument Panel Padding — Remove and Install

### REMOVE, DISCONNECT

- 1 Centre console.
2. Footwell panelling.
3. Glove compartment.
4. Cover.
5. Centre, with heating operating unit.

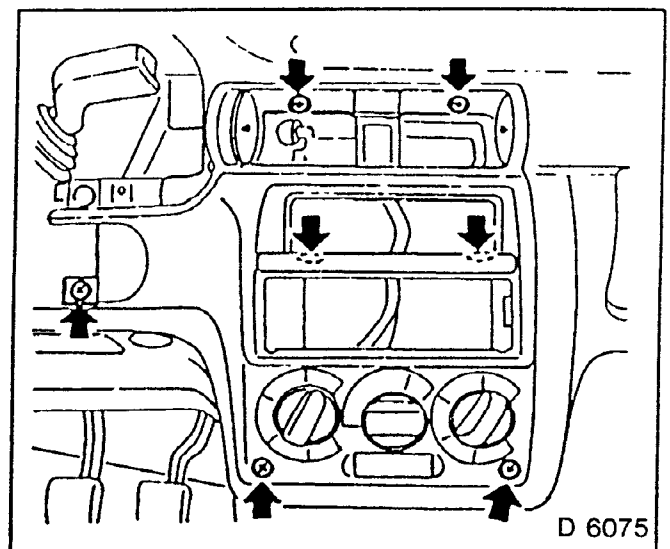


Fig. 64

6. Instrument housing.
7. Steering wheel.
8. Signal switch.
9. Wiper switch.
10. Heater vent housing.
11. Side (A) and (B) fastening.
12. Instrument panel padding.

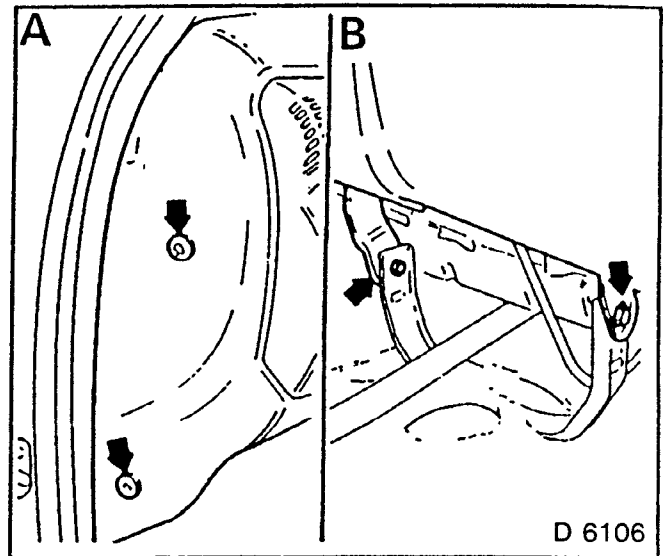


Fig 65

### REMOVE, DISCONNECT

1. Fuse box.
2. Screen wiper linkage.
3. Wiring/hose connections.
4. Instrument panel padding from bulkhead

### INSTALL, CONNECT

1. Instrument panel padding.
2. Screen wiper linkage.
3. Wiring/hose connections
4. Fuse box.
5. Heating vent housing.
6. Signal switch/wiper switch.
7. Steering wheel.
8. Instrument housing.
9. Centre cover.
10. Glove compartment.
11. Footwell panelling.
12. Centre console.

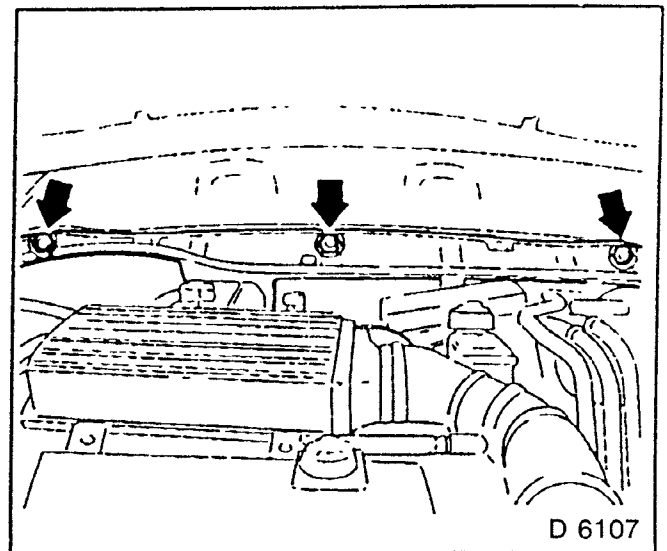


Fig 66

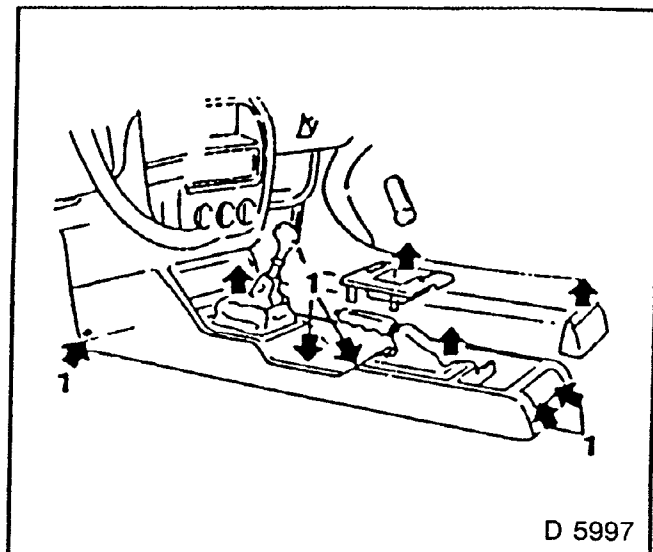
## Centre Console — Remove and Install

### REMOVE, DISCONNECT

1. Rear ashtray.
2. Centre storage compartment.
3. Shift lever folding cover.
4. Parking brake lever folding cover.
5. Centre console — six bolts (1).
6. "Seat heating" disconnect wiring plug, if fitted.

### INSTALL, CONNECT

1. Centre console.
2. Parking brake lever folding cover.
3. Shift lever folding cover.
4. Centre storage compartment.
5. Rear ashtray.



D 5997

Fig. 67

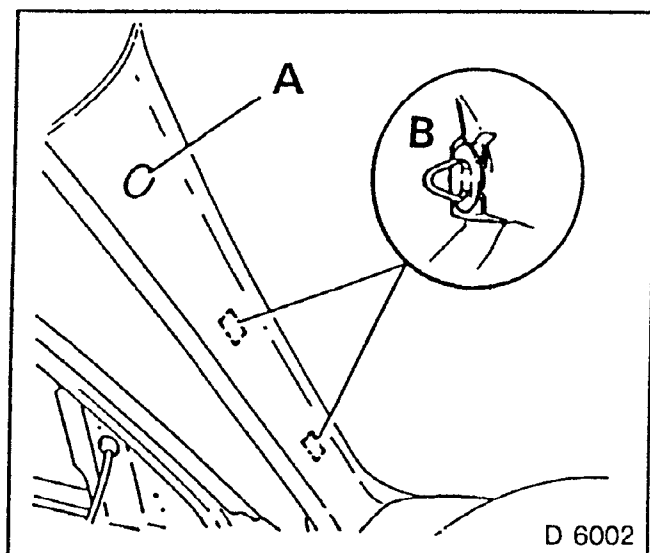
## A Pillar Upper Panelling — Disconnect and Connect

### REMOVE, DISCONNECT

- A pillar upper panelling.
1. One cover cap and bolt (A).
  2. Two spring clips (B).

### INSTALL, CONNECT

- A pillar upper panelling.



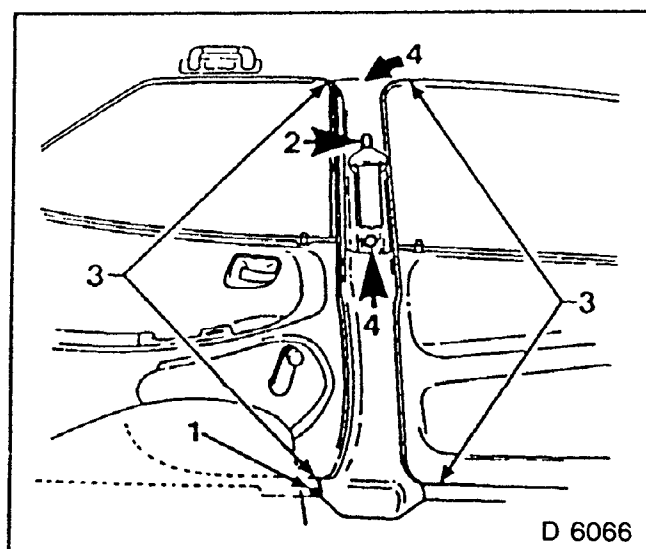
D 6002

Fig 68

## B Pillar Panelling (Kadett) — Remove and Install

### REMOVE, DISCONNECT

1. Loosen front bolt on rear sill panelling (1).
2. Belt fastening (2).
3. Remove door weatherstrip (3).
4. Two cover plugs and two bolts, above (4)
5. B pillar panelling.



D 6066

Fig. 69

**INSTALL, CONNECT**

1. B pillar panelling.
2. Door weatherstrip.
3. Belt fastening.
4. Sill panel bolt.

## C/D Pillar Panelling (Kadett) — Remove and Install

**REMOVE, DISCONNECT**

1. C pillar belt fastening.
2. Loudspeaker connecting cable.  
C/D pillar panelling.
3. Three cover caps, three bolts (1).
4. Six bolts (2).
5. One clip (rear side panelling) (3).

**INSTALL, CONNECT**

1. C/D pillar panelling.
2. Loudspeaker connecting cable
3. C pillar belt fastening.

**TIGHTEN, (TORQUE)**

1. C pillar belt fastening — 35 Nm.

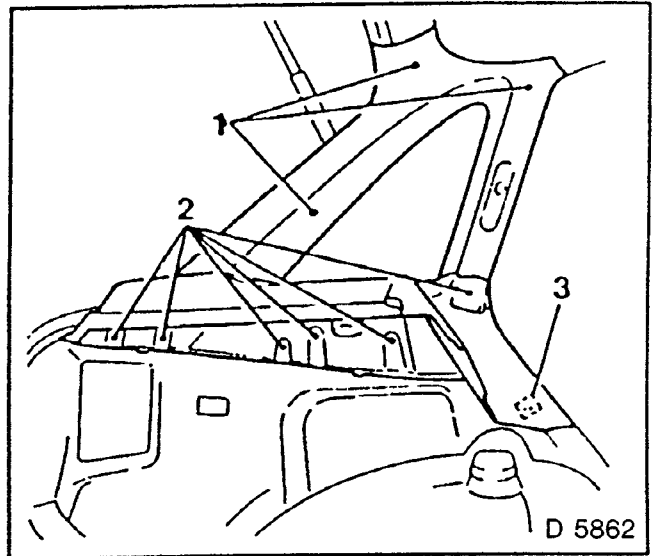


Fig. 70

## C/D Pillar Panelling (Astra) — Remove and Install

**REMOVE, DISCONNECT**

C pillar seat belt fastening.

1. Two cover caps, two bolts (1).
2. One bolt (2).
3. Two spring clips (3).

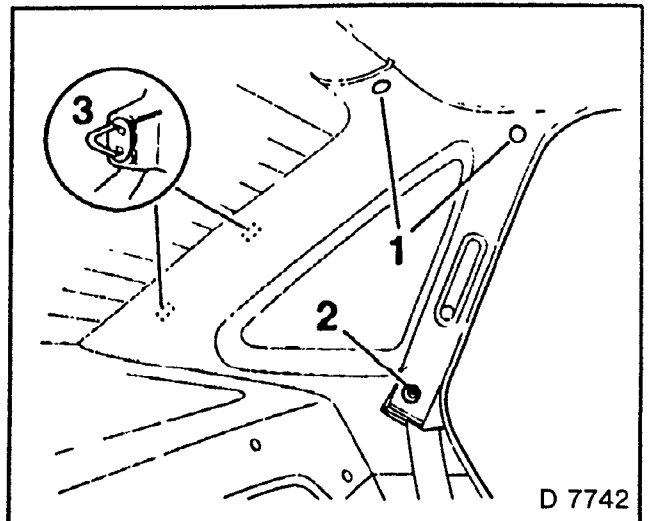


Fig. 71

**INSTALL, CONNECT**

1. C/D pillar panelling.
2. C pillar seat belt fastening.

**TIGHTEN, (TORQUE)**

C pillar seat belt fastening — 35 Nm.

**Sill Panelling, Front  
Disconnect and Connect**

**REMOVE, DISCONNECT**

Sill panelling.

1. Lever off three cover panels (1) three bolts.
2. One cover cap, one bolt (2).

**INSTALL, CONNECT**

1. Sill panelling.

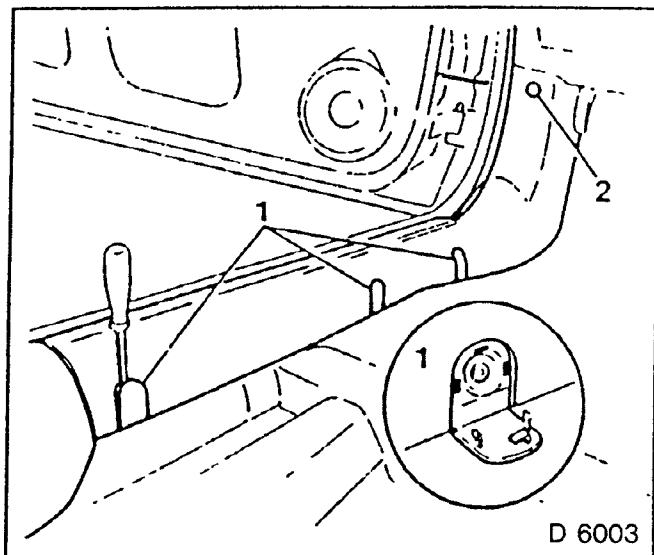


Fig 72

**Sill Panelling, Rear —  
Remove and Install**

**REMOVE, DISCONNECT**

- 1 Sill panelling.
2. Lever off cover panels, two bolts

**INSTALL, CONNECT**

1. Sill panelling.

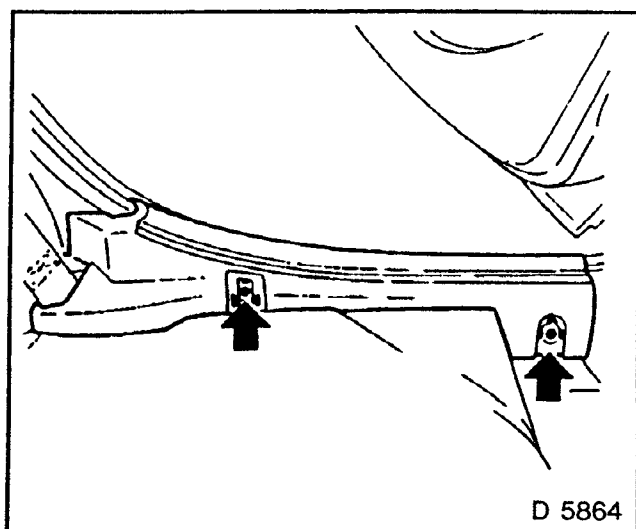


Fig 73

## Rear End Panel Shelf — (Astra) Remove and Install

### REMOVE, DISCONNECT

1. All C/D pillar panelling.
2. Edge strip.
3. Rear end panel shelf.
4. Six clips (1).
5. Pull out shelf forwards (2).

### INSTALL, CONNECT

1. Rear end panel shelf.
2. Edge strip.
3. C/D pillar panelling.

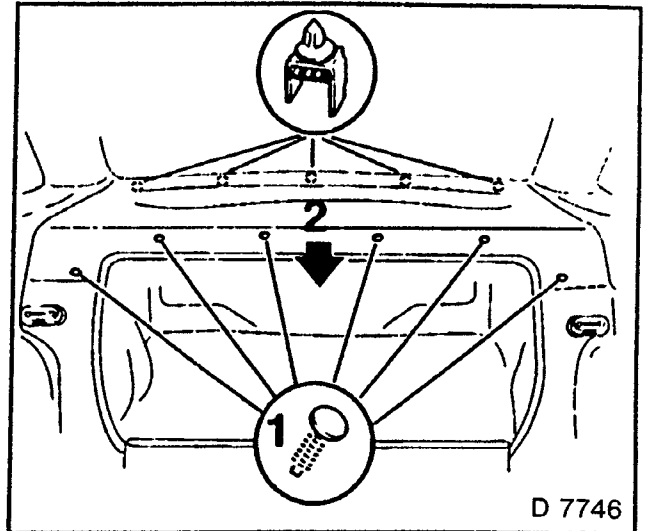


Fig 74

## Rear Quarter Panelling, Rear (Kadett) — Remove and Install

### REMOVE, DISCONNECT

#### Rear quarter panelling.

Fig. 75 shows left side.

1. Luggage compartment illumination (1).
2. One first aid kit retaining strap bolt (2)
3. Seven clips — KM — 475 — A (3).

#### Right side

4. Six clips — KM 475 — A

### INSTALL, CONNECT

1. Rear quarter panelling.
2. First aid kit retaining strip.
3. Luggage compartment illumination.

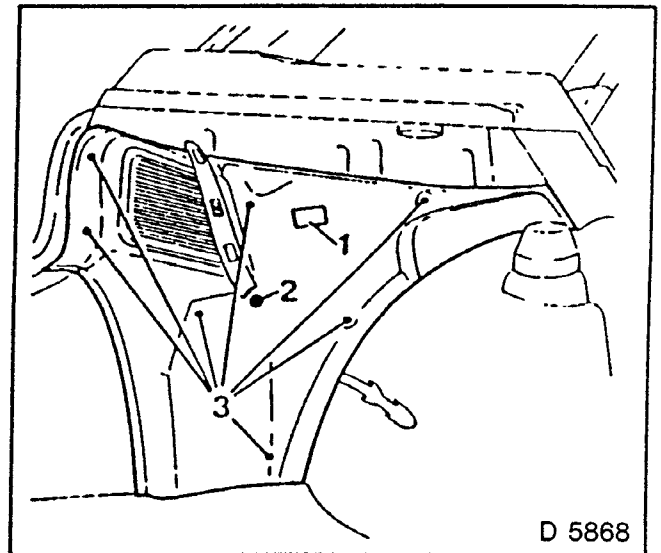


Fig 75

## Rear Quarter Panelling, Rear Section (Astra) — Remove and Install

### REMOVE, DISCONNECT

#### Rear quarter panelling.

1. Open screws (1).
2. Unscrew body — bound rivet pin (2).
3. Lever out body — bound rivet.

### INSTALL, CONNECT

1. Rear quarter panelling.

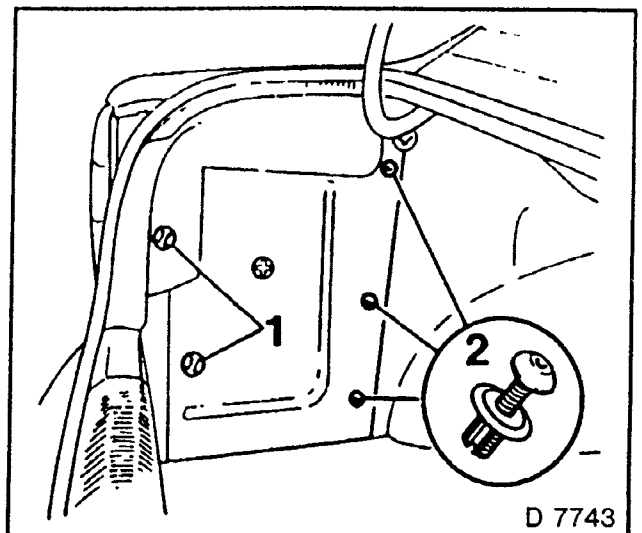


Fig. 76

## Rear Wheel Well Panelling (Astra) — Remove and Install

### REMOVE, DISCONNECT

Rear section of rear quarter panelling.

1. Remove edge strip partially (1).
2. Wheel well panelling.
- 3 Six clips (2).

### INSTALL CONNECT

1. Wheel well panelling.
2. Edge strip.
3. Rear section of rear quarter panelling.

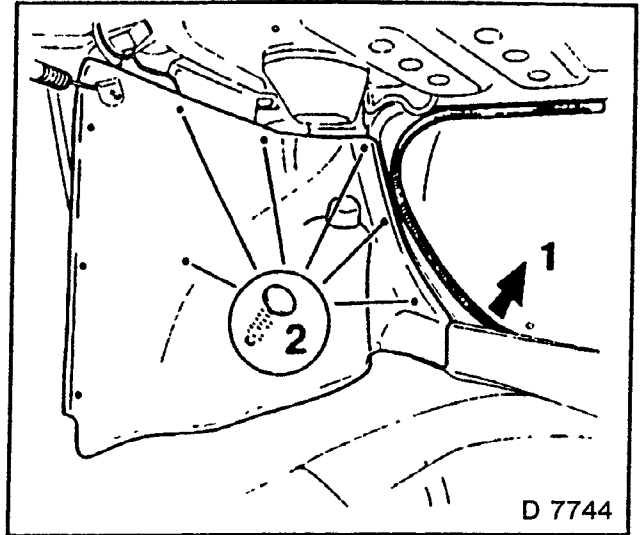


Fig. 77

## Rear End Lower Panelling — Remove and Install

### REMOVE, DISCONNECT

Rear end lower panelling.

1. Four bolts (1).
2. Four snap fasteners (2).

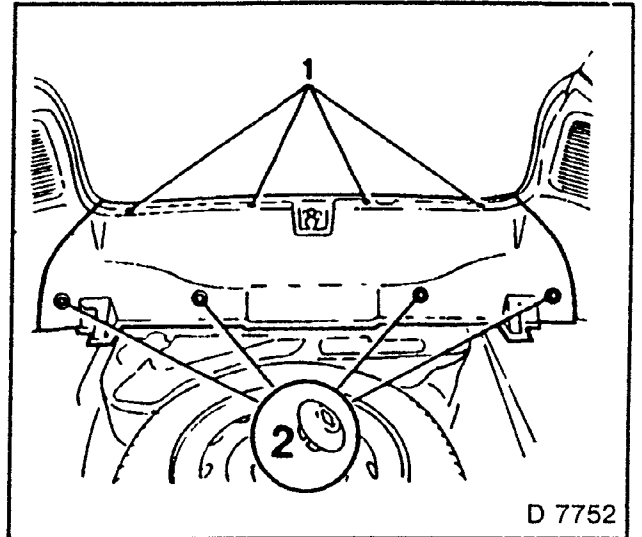


Fig. 78

### INSTALL, CONNECT

1. Rear end panelling.

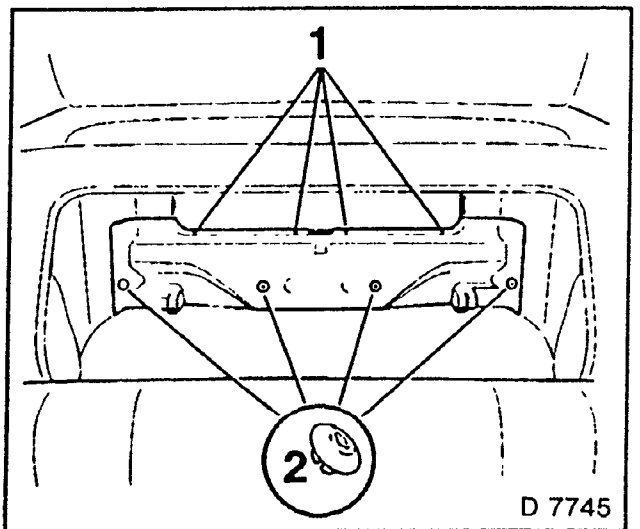


Fig. 79

## Tailgate Panelling — Remove and Install

### REMOVE, DISCONNECT

#### Tailgate panelling.

1. Torx bolts with MKM — 604 — A (1).
2. Cover caps and bolts (2).
3. Cover caps and bolts (3).
4. Retaining stud (4).

### INSTALL, CONNECT

1. Tailgate panelling.

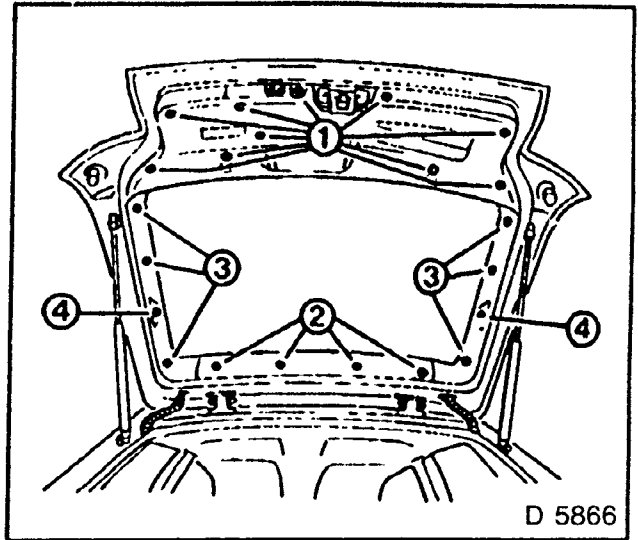
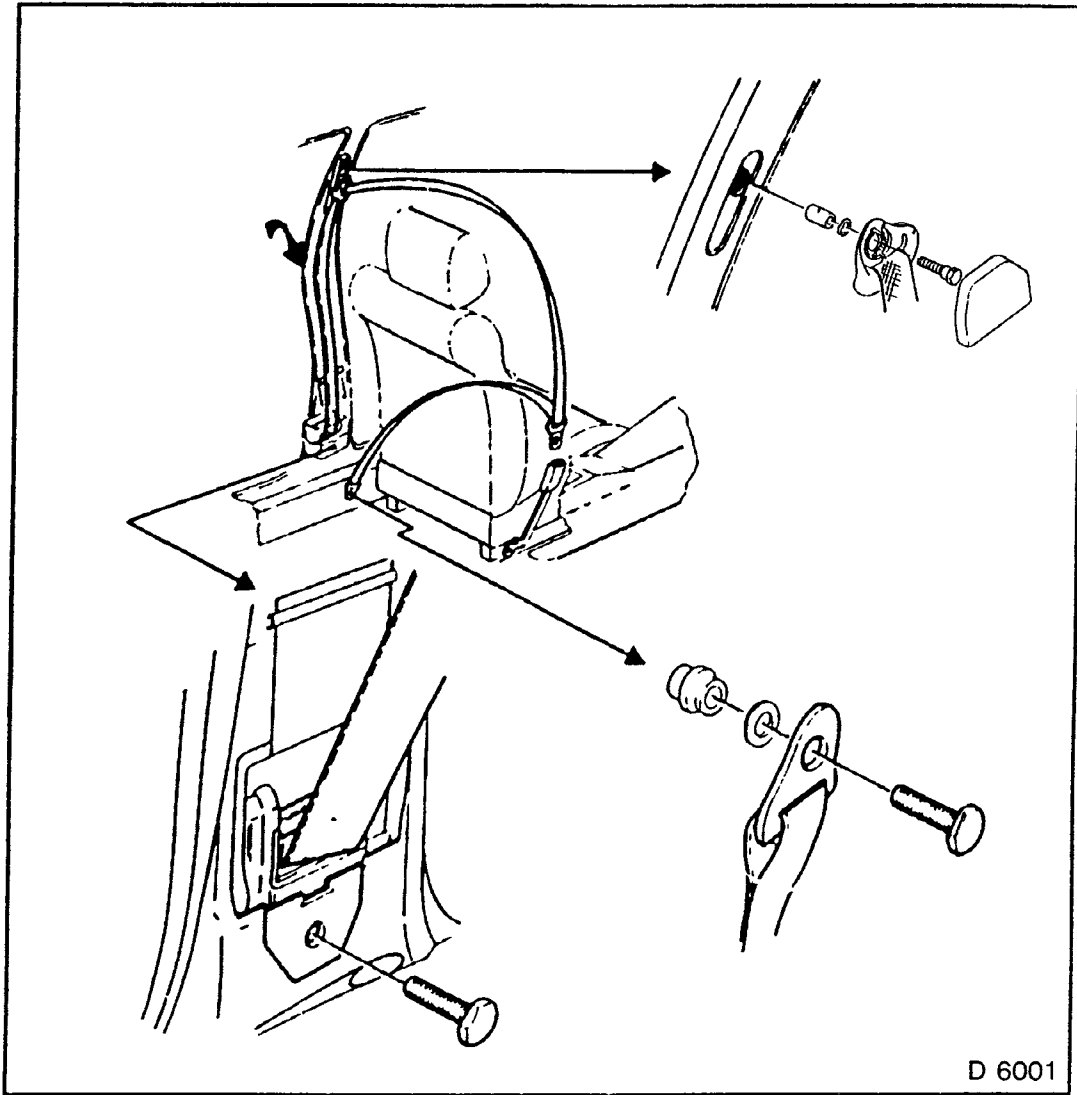


Fig. 80





D 6001

Fig 81

## Seat Belt, Front — Remove and Install or Replace

### REMOVE, DISCONNECT

#### B pillar lower panelling.

1. Lower belt fastening.
2. Belt return fitting.
3. Inertia reel retractor.

### INSTALL, CONNECT

1. Inertia reel retractor.
2. Belt return fitting.
3. Lower belt fastening.
4. B pillar lower panelling.

### TIGHTEN (TORQUE)

Belt to body — 35 Nm.

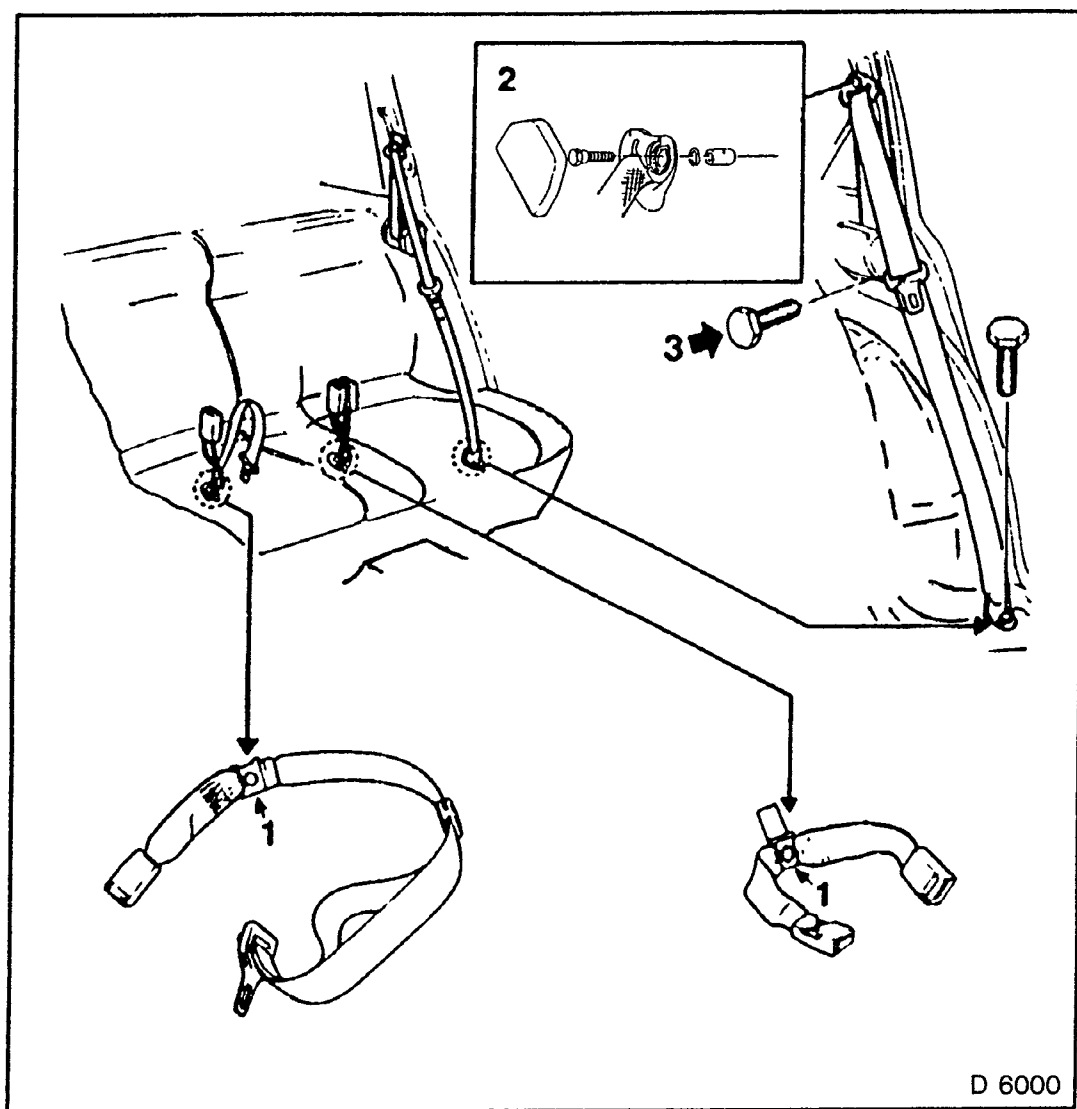


Fig 82

## Seat Belt, Rear — Remove and Install or Replace

### REMOVE, DISCONNECT

1. Fold over rear seat.
2. Remove belt locks and lap belt (1) from floor panel.
3. Rear quarter panelling.
4. Belt return fitting (2)
5. Inertia reel retractor (3).

### INSTALL, CONNECT

1. Inertia reel retractor.
2. Belt return fitting.
3. Belt locks and lap belt.
4. Rear quarter panelling.

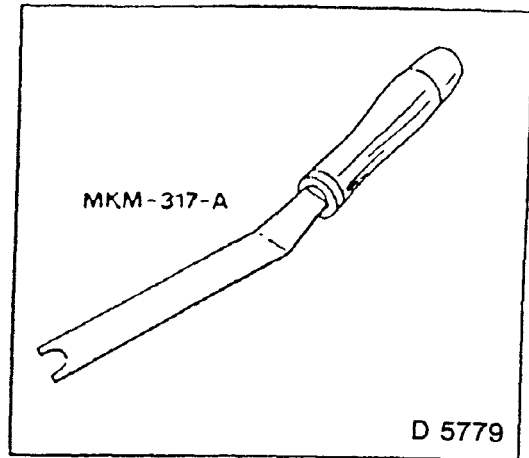
### TIGHTEN (TORQUE)

Belt fastening points to body — 35 Nm.

## Special Service Tools

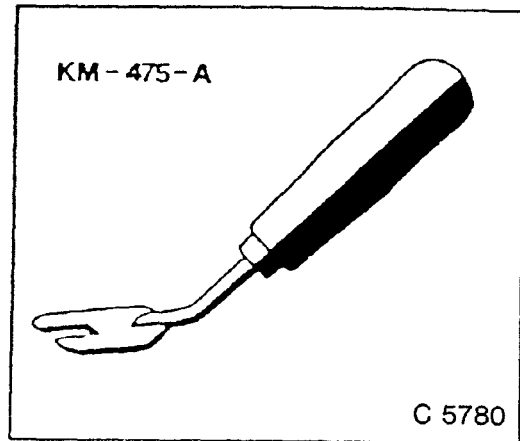
### **KM — 317 — A Remover.**

To remove the door handle and window winder.



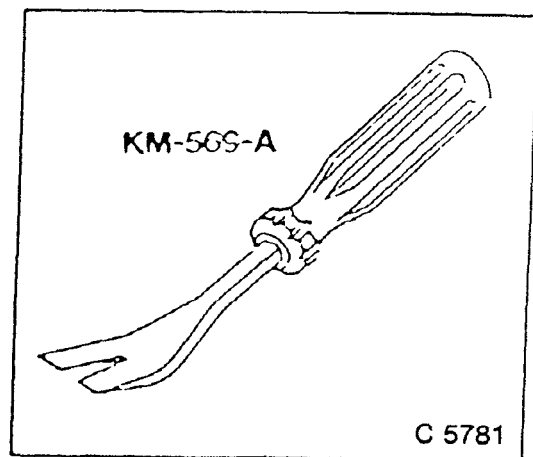
### **KM — 475 — A Trim Remover.**

To press off door inner panelling.



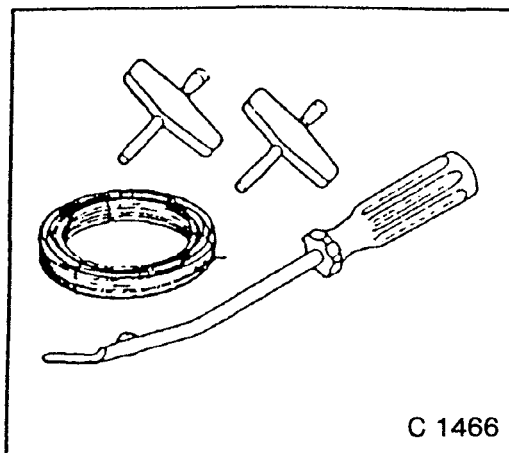
### **KM — 569 — A Plug Lifter.**

To remove headrest sleeves.



**MKM — 589 — A Wire Cutter.**

To cut out cemented windows.



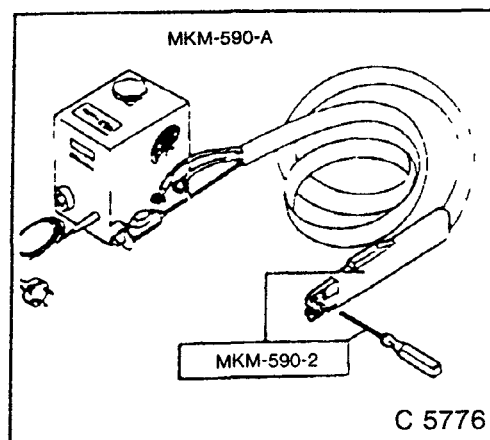
**MKM — 590 — A Thermo Knife.**

To cut out cemented windows, consisting of:  
 MKM — 590 — 1 Heating Unit (220 volts).

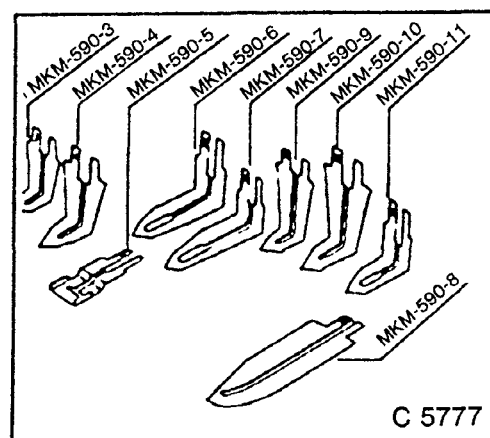
MKM — 590 — 2 Cutting Handle (with screwdriver).

MKM — 590 — Knife.

(If required can be supplied individually, and figure of MKM — 590 identification is stamped on clamping area).



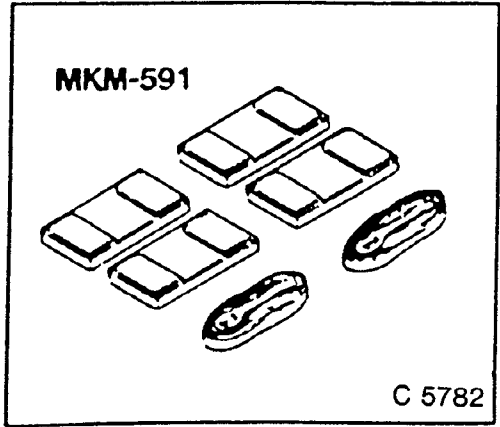
- 3 — Knife (Angle, 18 mm/0.71 in. long)
- 4 — Knife (Angle, 33 mm/1.30 in long)
- 5 — Scraper (18 mm/0.71 in. wide)
- 6 — Knife (Angle, 55 mm/2.16 in long)
- 7 — Knife (Angle, 60 mm/2.36 in long)
- 8 — Knife (Angle, 80 mm/3.15 in long)
- 9 — Knife (Angle, 18 mm/0.71 in. long;  
Clamper 46 mm/1.89 in. long)
- 10 — Knife (Angle, 33 mm/1.30 in. long;  
Clamper 46 mm/1.89 in. long)
- 11 — Knife (Angle 40 mm/1.57 in.)



**MKM — 591 — Tensioning Belt.**

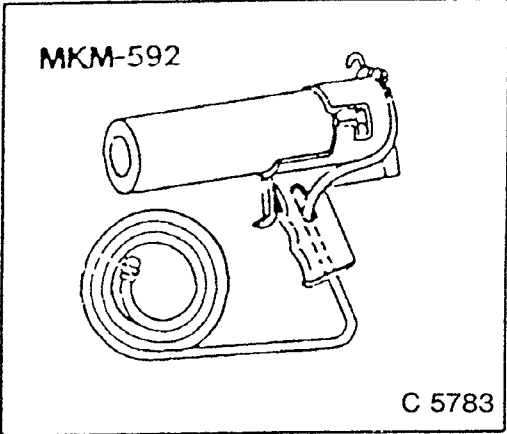
To position windows during installation.

C — 91



**MKM — 592 Compressed Air Pistol.**

To apply sealing compounds and cement from normal cartridges, approx. 300 ml/0.07 gals.

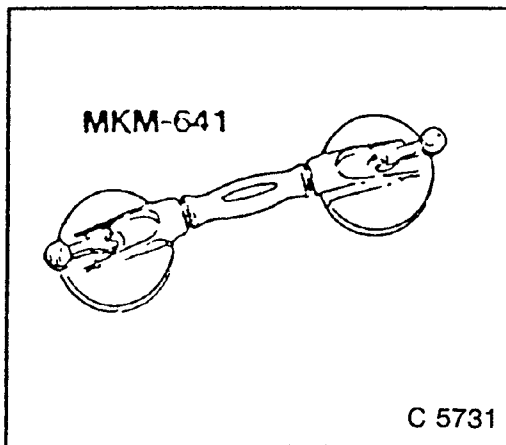


**MKM — 604 — A Torx Bit and Socket Set.**



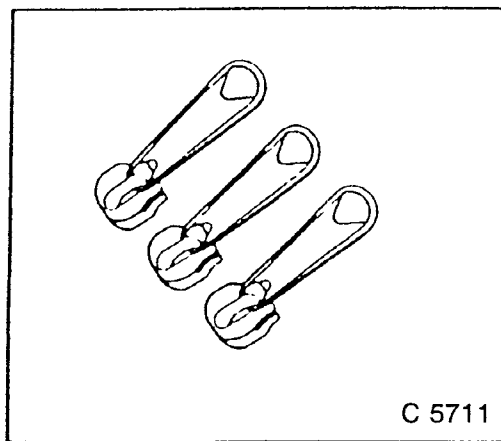
**MKM — 641 Window Pane Suction Lifter.**

To hold panes firm during removal or installation.



**KM — 643 Mounting Set.**


Pack of 3 pieces to install rear seat armrest upholstery cover.



## TECHNICAL DATA

### RECOMMENDED TORQUE VALUES

	Nm
Belt fastening to pillar.....	35
Belt lock tensioner to seat.....	35
Belt lock to body.....	35
Belt lock to seat.....	35
Belt to body.....	35
Height adjuster to pillar.....	20
Inertia reel retractor to pillar.....	35
Operating unit bolts.....	5
Seat to underbody.....	20
Tailgate hinge to roof frame.....	20

**Opel Astra**  **Opel Kadett**

## **Workshop Manual**

### **Section D**

# **Heating and Ventilation System, Air Conditioning**

Issued by: Service Division  
Delta Motor Corporation  
July, 1993



# HEATING AND VENTILATION



## Index

	<i>Page</i>
ARRANGEMENT OF COMPONENTS FOR MIXED AIR HEATING.....	D- 2
VENTILATION NOZZLE INSET — REMOVE AND INSTALL.....	D- 3
VENTILATION NOZZLE HOUSING — REMOVE AND INSTALL (DRIVER'S SIDE) .....	D- 3
VENTILATION NOZZLE HOUSING — REMOVE AND INSTALL (PASSENGER SIDE) .....	D- 4
COVER, CENTRE — REMOVE AND INSTALL.....	D- 5
HEATING OPERATING UNIT — REMOVE AND INSTALL .....	D- 8
MIXED AIR FLAP BOWDEN CABLE — REPLACE.....	D- 9
BOWDEN CABLE FOR UPPER AIR DISTRIBUTION — REPLACE.....	D- 9
BOWDEN CABLE FOR LOWER AIR DISTRIBUTION — REPLACE. . . . .	D-10
HEATER CORE — REMOVE AND INSTALL . . . . .	D-12
HEATER CORE (AIR CONDITIONING) — REMOVE AND INSTALL.....	D-13
AIR DISTRIBUTION HOUSING — REMOVE AND INSTALL.....	D-15
FAN MOTOR — REMOVE AND INSTALL . . . . .	D-16
FAN HOUSING — REMOVE AND INSTALL . . . . .	D-17
FAN MOTOR SERIES RESISTOR — REPLACE.....	D-18
MIXED AIR/AIR CON. SWITCH — REMOVE AND INSTALL.....	D-18
SWITCH FOR FAN/HEATED REAR SCREEN — REMOVE AND INSTALL .....	D-18
MIXED AIR ACTUATION VACUUM UNIT — REPLACE .....	D-19

# AIR CONDITIONING

## Index

	<i>Page</i>
GENERAL INSTRUCTIONS FOR THE REPAIR AND STORAGE OF AIR CONDITIONING COMPONENTS . . . .	D-22
SAFETY REGULATIONS FOR HANDLING REFRIGERANT . . . . .	D-23
AIR CONDITIONING ARRANGEMENT . . . . .	D-24
AIR DISTRIBUTION IN VEHICLE . . . . .	D-25
OPERATING CONTROLS . . . . .	D-26
ADJUSTING THE COOLING FUNCTIONS . . . . .	D-26
MAXIMUM COOLING . . . . .	D-26
NORMAL COOLING . . . . .	D-26
AREA COOLING WITH TEMPERATURE LEVELS . . . . .	D-27
DEMISTING AND DE-ICING WINDOW PANES . . . . .	D-27
GLOVE COMPARTMENT REFRIGERATION . . . . .	D-27
REFRIGERANT CIRCUIT . . . . .	D-28
DESCRIPTION OF REFRIGERANT CIRCUIT . . . . .	D-29
COMPRESSOR . . . . .	D-30
CIRCUIT DIAGRAM — COMPRESSOR . . . . .	D-31
COMPRESSOR LUBRICANT . . . . .	D-32
COMPRESSOR LUBRICANT — TOP UP . . . . .	D-32
DESIGN OF COMPRESSOR . . . . .	D-32
DISPLACEMENT VARIATION . . . . .	D-33
PERFORMANCE CONTROL AND FUNCTIONING OF CONTROL VALVE . . . . .	D-34
HIGH PERFORMANCE REQUIREMENT . . . . .	D-35
LOW PERFORMANCE REQUIREMENT . . . . .	D-35
CONDENSER . . . . .	D-36
ACCUMULATOR . . . . .	D-37
ORIFICE VALVE . . . . .	D-38
EVAPORATOR . . . . .	D-38
AIR DISTRIBUTION IN AIR DISTRIBUTOR CASE . . . . .	D-39

BOOSTER FAN .....	D-40
CIRCUIT DIAGRAM — BOOSTER FAN.....	D-40
SERVICE CONNECTIONS .....	D-41
MOISTURE IN REFRIGERANT CIRCUIT.....	D-41
LEAK DETECTION IN REFRIGERANT CIRCUIT.....	D-42
AIR CONDITIONING — DRAIN .....	D-43
AIR CONDITIONING — EVACUATE AND CHARGE....	D-46
ACCUMULATOR — REMOVE AND INSTALL .....	D-47
CONDENSOR — REMOVE AND INSTALL .....	D-47
ACCUMULATOR — REPLACE.....	D-47
BOOSTER FAN — REMOVE AND INSTALL.....	D-50
EVAPORATOR — REMOVE AND INSTALL.....	D-50
PIPES AND HOSES ..	D-52
PIPE AND HOSE LINES — REMOVE AND INSTALL.....	D-52
LOCATION OF SWITCHES .....	D-53
TRIPLE SWITCH .....	D-54
LOW PRESSURE SAFETY SWITCH.....	D-54
HIGH PRESSURE SAFETY SWITCH .....	D-54
BOOSTER FAN SWITCH.....	D-54
MOTRONIC SWITCH.....	D-54
COOLANT TEMPERATURE SWITCH ..	D-54
COOLANT TEMPERATURE SWITCH — REPLACE .....	D-56
TRIPLE SWITCH — REPLACE. . . . .	D-56
MOTRONIC SWITCH — REPLACE ..	D-56
COMPRESSOR — REMOVE AND INSTALL.....	D-56
COMPRESSOR CLUTCH — REPLACE . . . . .	D-60
COMPRESSOR PULLEY ASSEMBLY — REPLACE..	D-61
COMPRESSOR SAFETY VALVE — REPLACE. ....	D-62
COMPRESSOR CONTROL VALVE — REPLACE. ....	D-62
VALVE — GLOVE COMPARTMENT COOLING — REPLACE.....	D-63
<b>SPECIAL SERVICE TOOLS</b> .....	D-64
<b>TECHNICAL DATA</b> .....	D-67

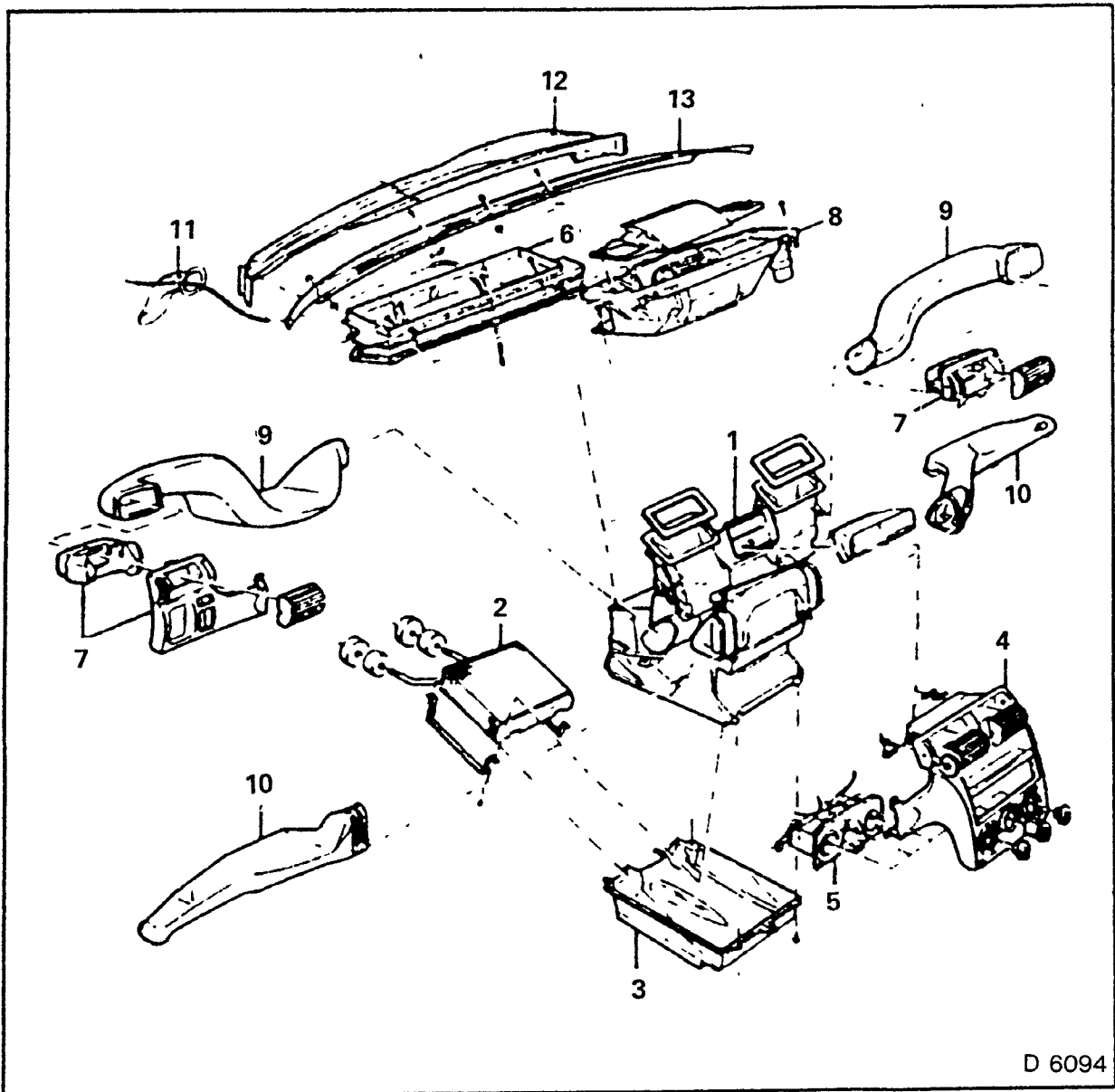


Fig 1

## Arrangement of Components for Mixed Air Heating

- 1 — Air distribution housing
- 2 — Heater core
- 3 — Heater core lower cover
- 4 — Cover, centre
- 5 — Heating operating unit
- 6 — Water housing
- 7 — Ventilation nozzle housing
- 8 — Fan
- 9 — Side air distribution duct
- 10 — Centre air distribution duct
- 11 — Water drainage
- 12 — Water deflector
- 13 — Wind protective panelling

## Ventilation Nozzle Inset — Remove and Install

### REMOVE, DISCONNECT

1. Lever out ventilation nozzle inset.

### INSTALL, CONNECT

1. Press in ventilation nozzle inset until it catches.

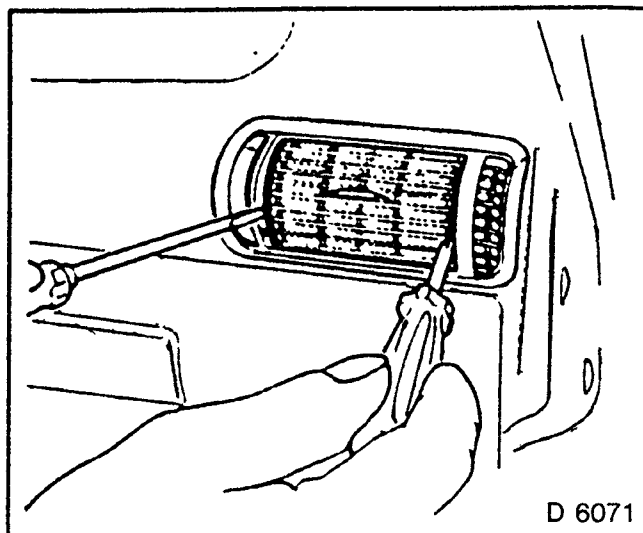


Fig. 2

## Ventilation Nozzle Housing, — Remove and Install (Driver's Side)

### REMOVE, DISCONNECT

1. Signal switch panelling.
2. Switch for lamps
3. Fog lamp.
4. Headlamp height adjustment — Section N.
5. Ventilation nozzle inset.

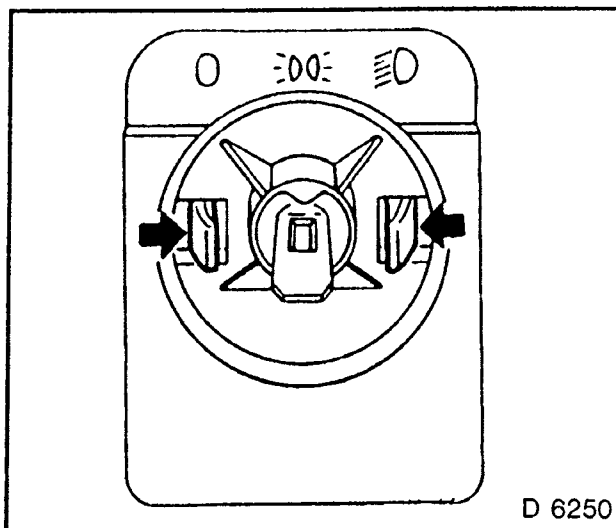


Fig. 3

### REMOVE, DISCONNECT

1. Ventilation nozzle housing.
2. Wiring harness plug.

### INSTALL, CONNECT

1. Wiring harness plug.
2. Ventilation nozzle housing — check connection to air duct.
3. Ventilation nozzle inset.
4. Switch.
5. Signal switch panelling.

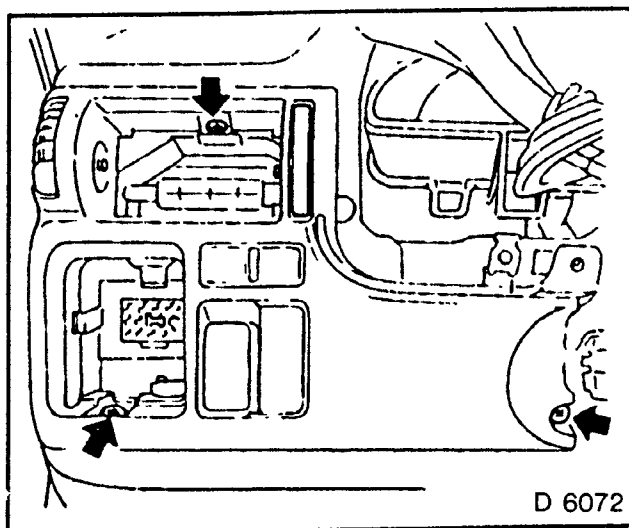


Fig. 4

## Ventilation Nozzle Housing, — Remove and Install (Passenger Side)

### REMOVE, DISCONNECT

1. Ventilation nozzle inset.
2. Glove compartment.
3. Ventilation nozzle housing.

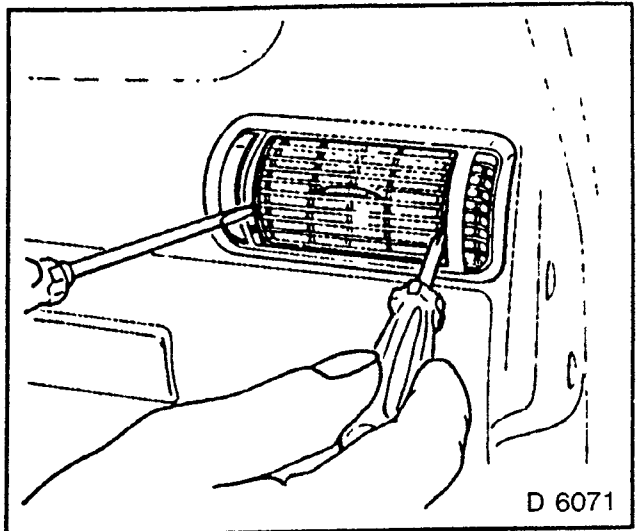


Fig. 5

### INSTALL, CONNECT

1. Ventilation nozzle housing — check connection to air duct.
2. Glove compartment.
3. Ventilation nozzle inset.

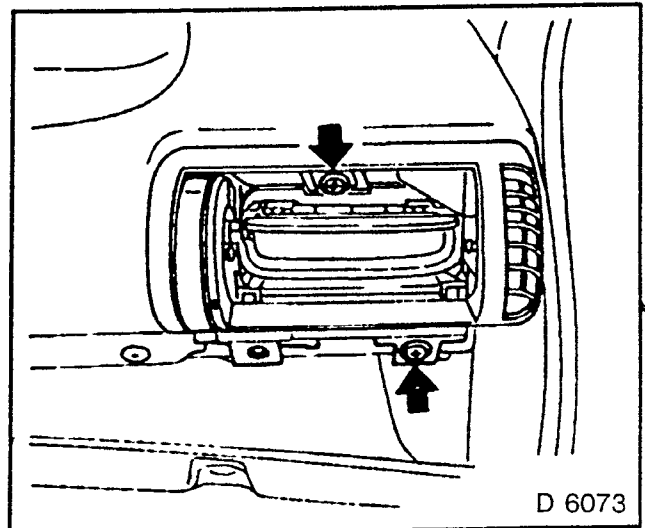


Fig. 6

# Cover, Centre, — Remove and Install

## REMOVE, DISCONNECT

- 1. Signal switch panelling — Section N.

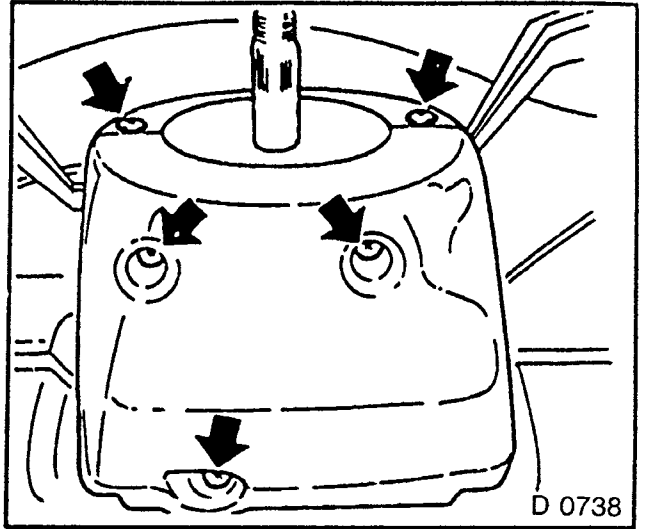


Fig. 7

## INSTALL, DISCONNECT

- 1. Instrument housing cover.

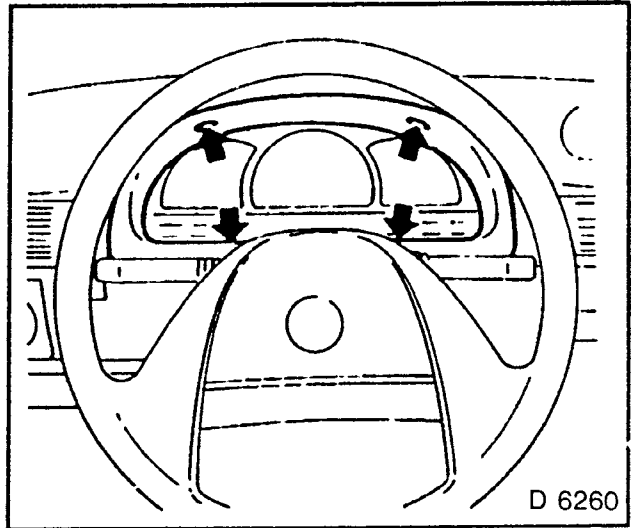


Fig. 8

## REMOVE, DISCONNECT

- 1. Hazard warning lamps switch, function display — Section N
- 2. Radio recess — Section R.

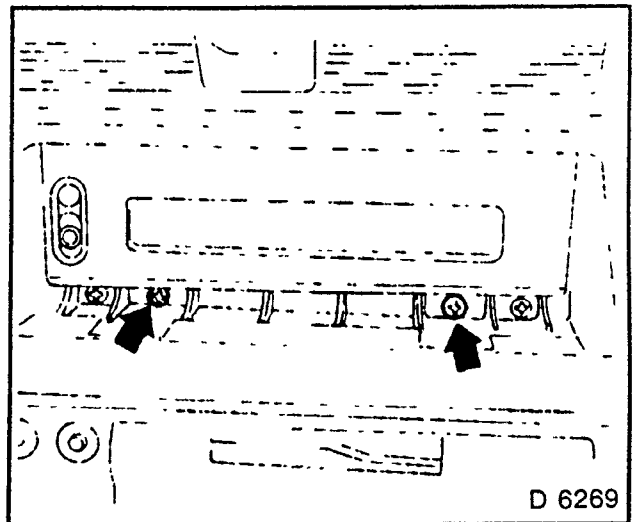


Fig. 9

**REMOVE, DISCONNECT**

1. Centre ventilation nozzle insets.

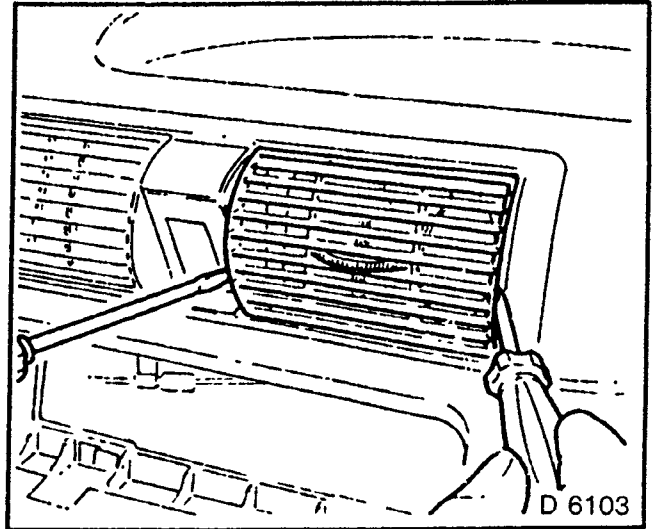


Fig. 10

**REMOVE, DISCONNECT**

1. Unclip actuating rod sideways from carrier.

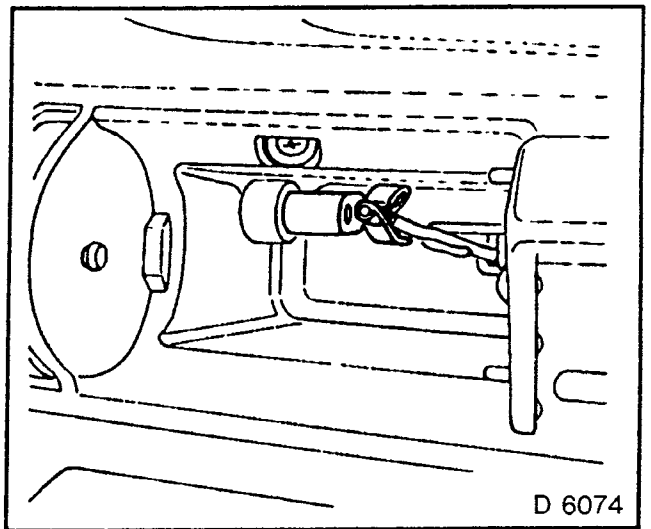


Fig. 11

**REMOVE, DISCONNECT**

1. Cover.
2. Centre.

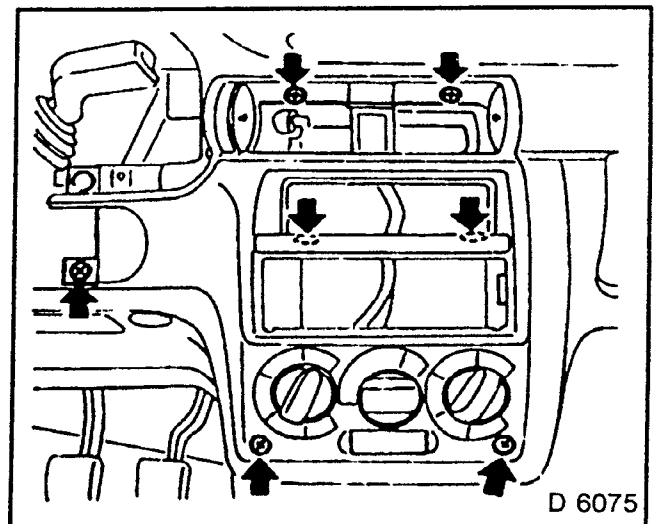


Fig. 12



**REMOVE, DISCONNECT**

1. Switch for ventilation/heating/fan.
2. Heating operating unit.
3. Hazard warning lamps wiring harness plug.

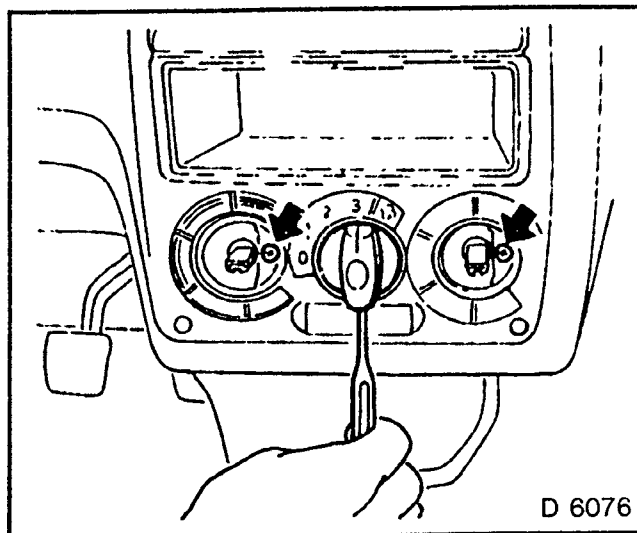


Fig. 13

**INSTALL, CONNECT**

1. Hazard warning lamps wiring harness plug.
2. Heating operating unit.
3. Cover.
4. Centre.
5. Switch.
6. Actuating rod — ventilation flap must close fully.
7. Ventilation nozzle insets
8. Radio
9. Function display
10. Hazard warning lamps switch.
11. Instrument housing cover.
12. Signal switch panelling.

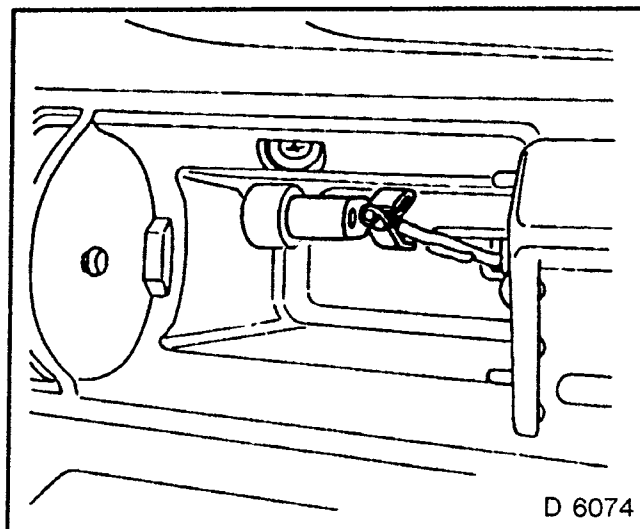


Fig. 14

# Heating Operating Unit — Remove and Install

## REMOVE, DISCONNECT

1. Cover.
2. Centre — Section D.

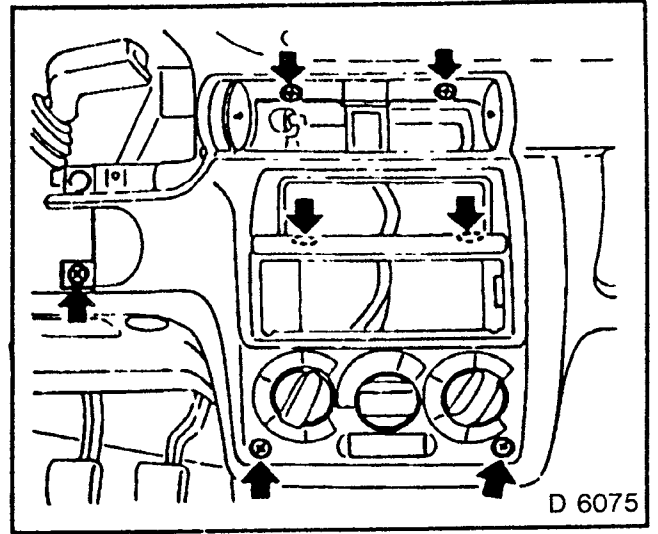


Fig 15

## REMOVE, DISCONNECT

1. Bowden cables.
- 2 Mixed air/AC switch
- 3 Wiring plug.

## INSTALL, CONNECT

1. Wiring plug.
- 2 Mixed air/AC switch.
3. Bowden cables.
- 4 Cover.
5. Centre.

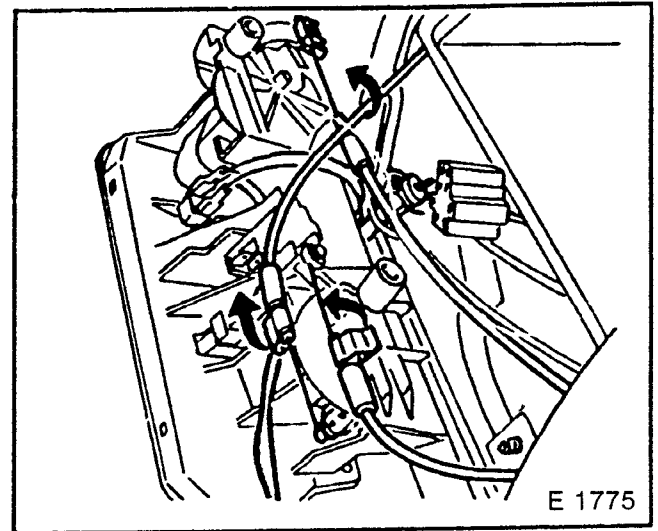


Fig 16

## Mixed Air Flap Bowden Cable — Replace

### REMOVE, DISCONNECT

1. Cover.
2. Centre.
3. Heating operating unit — Section D.

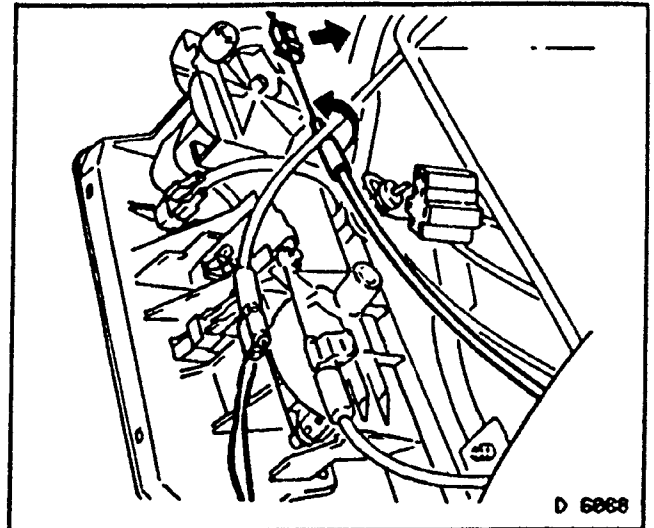


Fig. 17

### REMOVE, DISCONNECT

1. Footwell panelling/storage compartment (passenger side).
2. Vehicles with air conditioning only: airduct.
3. Bowden cable.

### INSTALL, CONNECT

1. Check for correct operation of Bowden cable (Bowden cable can be moved within the clip on the operating unit).
2. Footwell panelling/storage compartment (passenger side).
3. Heating operating unit

Fig. 18 applies to vehicles with air conditioning as well.

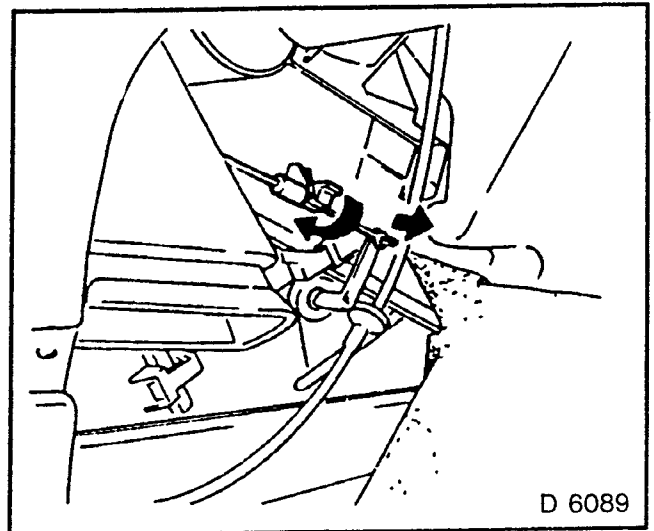


Fig. 18

## Bowden Cable for Upper Air Distribution — Replace

### REMOVE, DISCONNECT

1. Cover.
2. Centre, with heating operating unit — Section D.

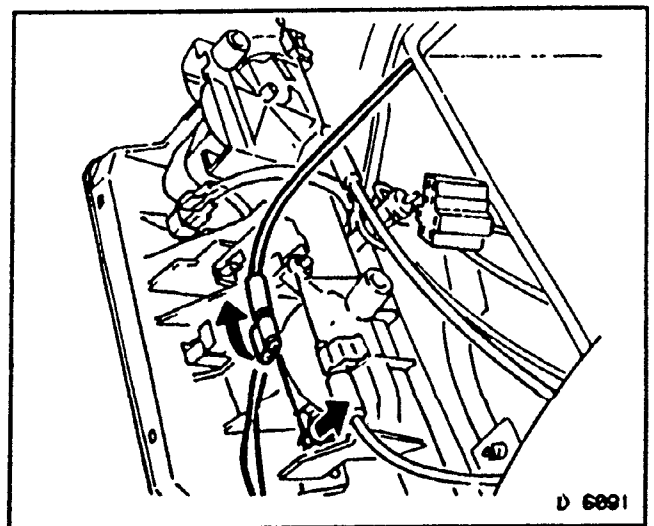


Fig. 19

**REMOVE, DISCONNECT**

1. Instrument housing — Section C.
2. Bowden cable.

**INSTALL, CONNECT**

1. Bowden cable.
2. Instrument housing.
3. Cover.
4. Centre.

Fig. 20 applies to vehicles with AC as well.

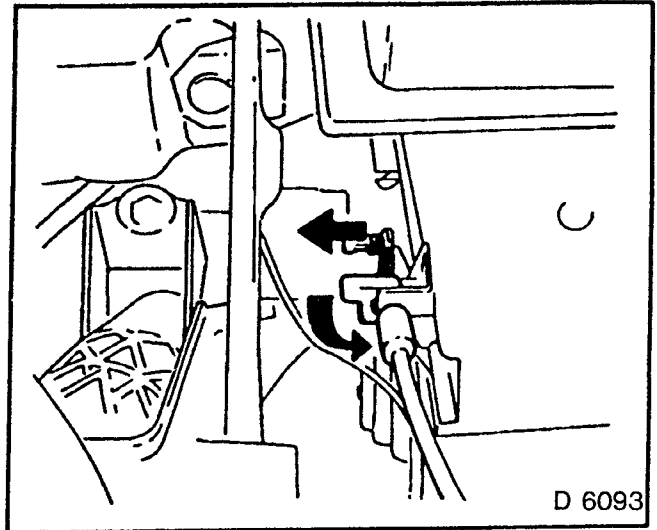


Fig. 20

**Bowden Cable for Lower Air Distribution — Replace****REMOVE, DISCONNECT**

1. Cover.
2. Centre, with heating operating unit — Section D.

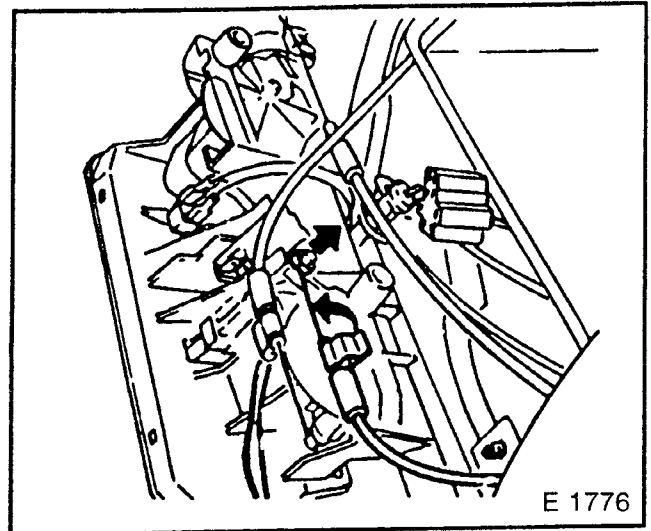


Fig 21

**VEHICLES WITHOUT AC:****REMOVE, DISCONNECT**

1. Bowden cable.

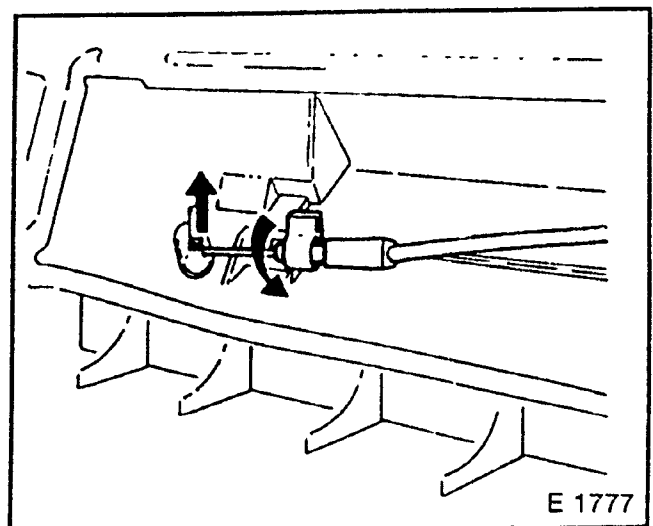


Fig. 22

**VEHICLES WITH AC:****REMOVE, DISCONNECT**

1. Glove compartment.
2. Bowden cable.

**INSTALL, CONNECT**

1. Bowden cable.
2. Glove compartment.
3. Cover.
4. Centre.

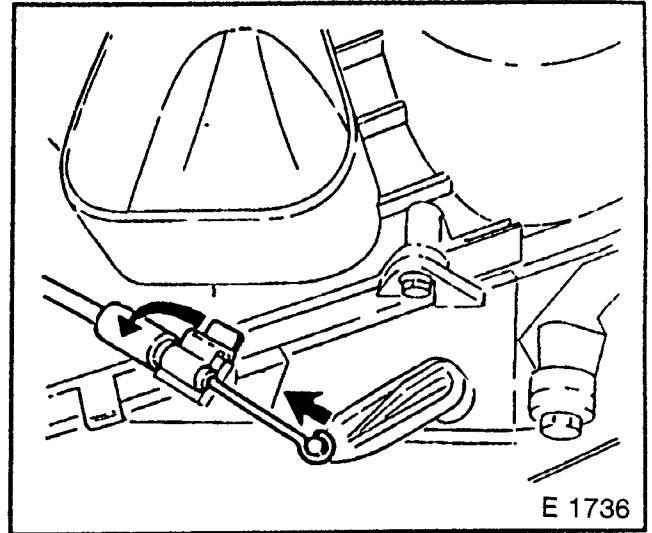


Fig. 23

## Heater Core — Remove and Install

### REMOVE, DISCONNECT

1. Heater core lower cover. See Section C.

For clearer representation fig. 24 shows instrument panel removed.

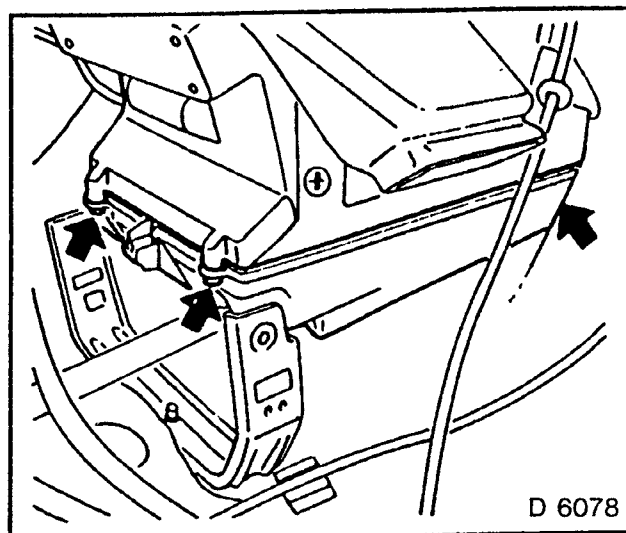


Fig. 24

### INSTALL, CONNECT

1. Hose clips on coolant hoses.

Feed hose = right

Return hose = left (to cooling system return flow).

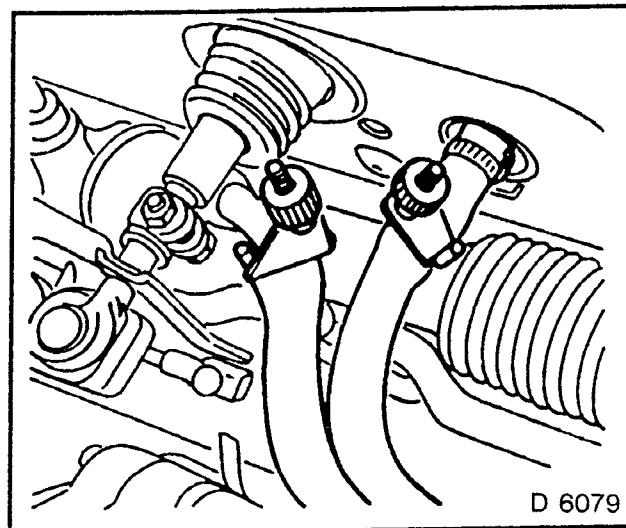


Fig 25

### REMOVE, DISCONNECT

1. Coolant hoses from heater core — collect coolant.
2. Close off heater core pipes
- 3 Heater core

### INSTALL, CONNECT

- 1 Heater core
2. Heater core lower cover.
3. Centre console.
4. Coolant hoses — remove hose clips.
5. Fill up coolant and bleed cooling system — Section J.

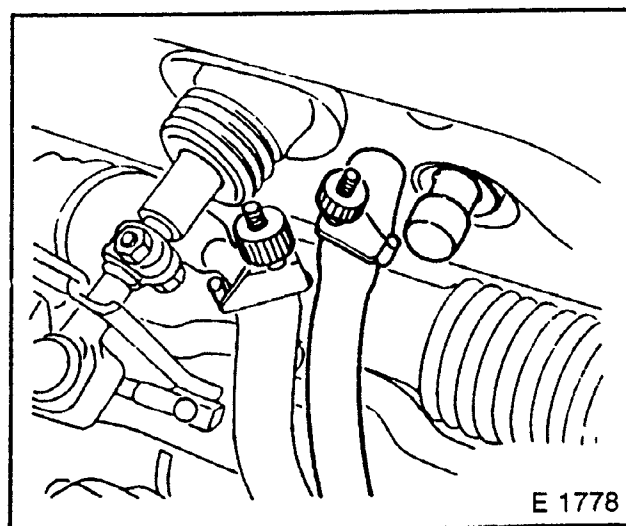


Fig 26

# Heater Core (Air Conditioning) — Remove and Install

## REMOVE, DISCONNECT

1. Hose clips from coolant hoses.
  1. Tube and orifice valve assembly.
  2. Evaporator to Accumulator Hose Assembly.
  3. Evaporator.
  4. Bulkhead Assembly.

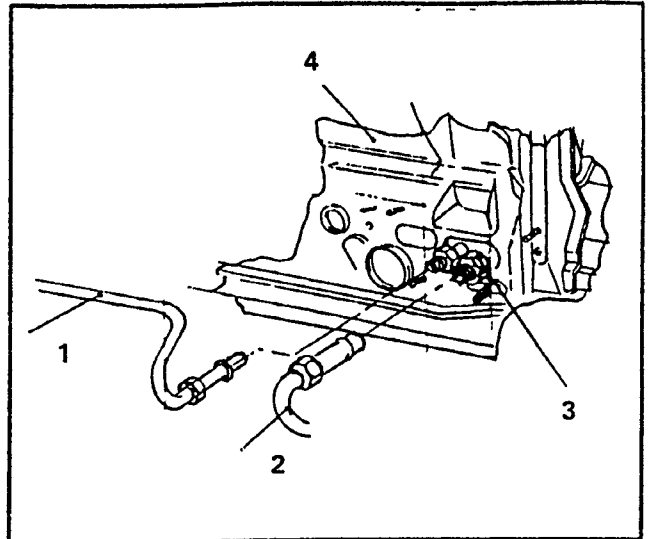


Fig. 27

2. Centre Console — Section C.
3. Footwell centre panelling.

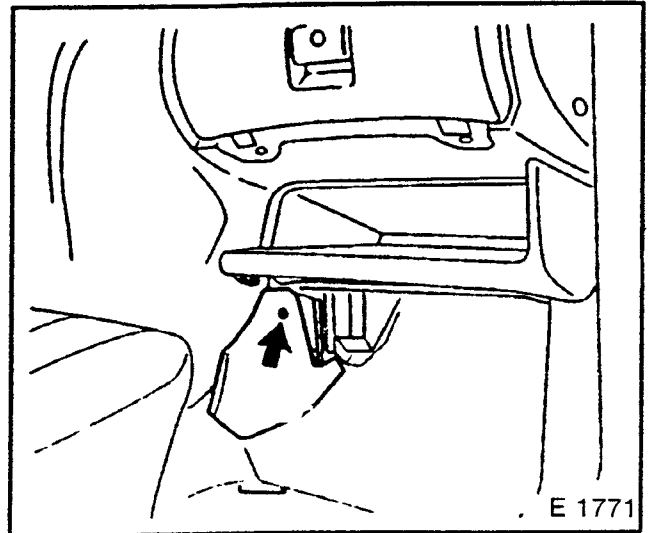


Fig. 28

## REMOVE, DISCONNECT

1. Rear airflow guide connection cover

Fig. 29 shows operation with air distribution housing removed

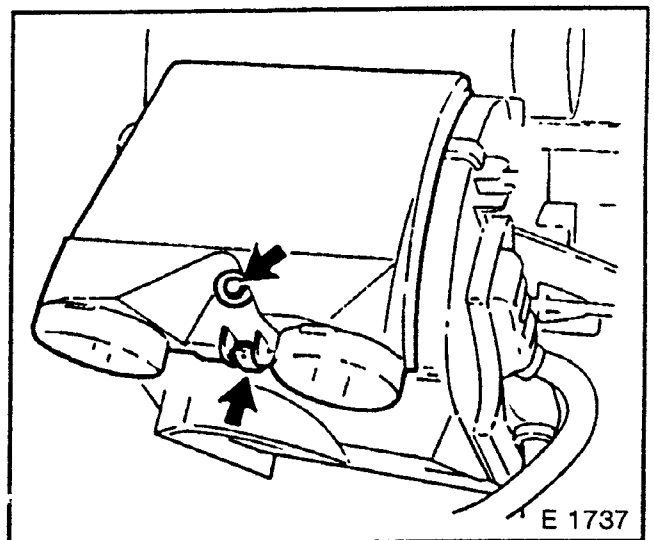


Fig. 29

2. Lower cover fastening bolts (1) — on revised version.
3. Release bolts (2)
4. Clamps (3).

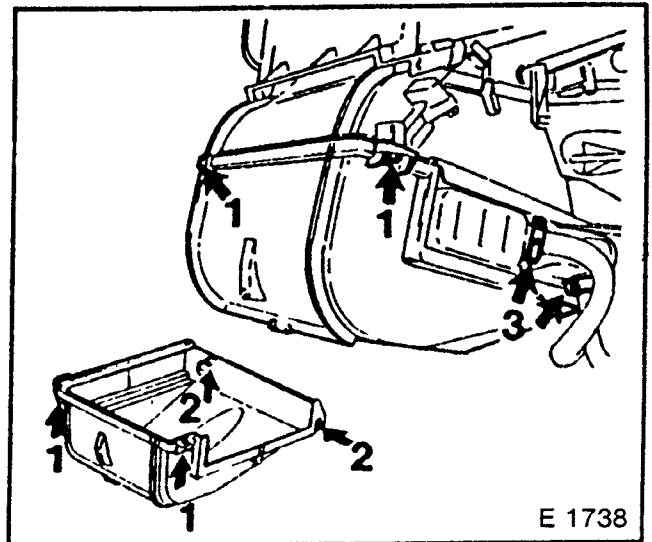


Fig. 30

### REMOVE, DISCONNECT

1. Pipes from heater core — collect any remaining coolant
2. Lower cover and heater core.
3. Heater core from lower cover.

### INSTALL, CONNECT

1. Heater core with new seals to lower cover.
2. Lower cover and heater core to air distribution housing.
3. Pipes to heater core — close off clamps
4. Rear air flow guide connection cover.
5. Footwell centre panelling.
6. Footwell storage compartment.
7. Centre console
8. Remove hose clips.
9. Fill coolant.

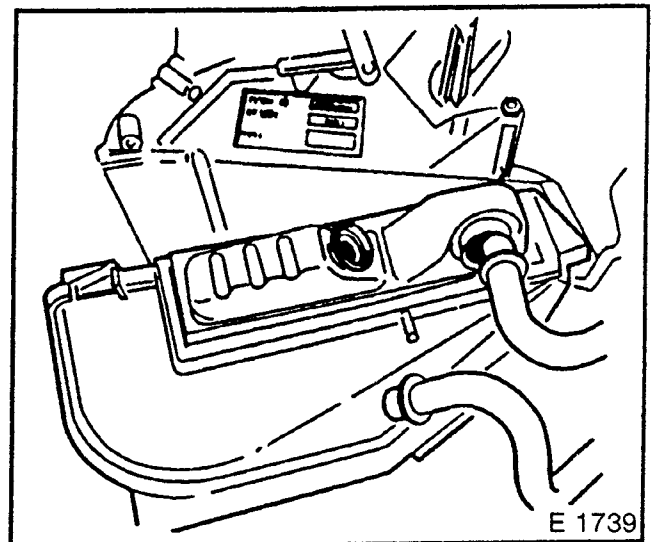


Fig. 31



# Air Distribution Housing — Remove and Install

## REMOVE, DISCONNECT

### VEHICLES WITH AC:

#### Drain AC — Section D.

1. Coolant hoses from heater core — using hose clips.
2. Collect coolant.
3. Close off heater core pipes.

Fig. 32 also applies to vehicles with AC.

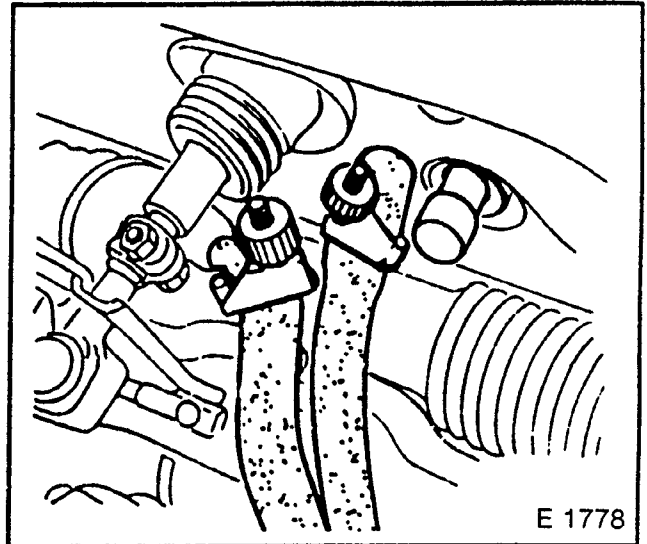


Fig. 32

### VEHICLES WITH AC:

1. Close off refrigerant line apertures.
2. Flange — condensation drain hose.
  1. Tube and orifice valve assembly
  2. Evaporator to Accumulator Hose Assembly.
  3. Evaporator.
  4. Bulkhead Assembly.

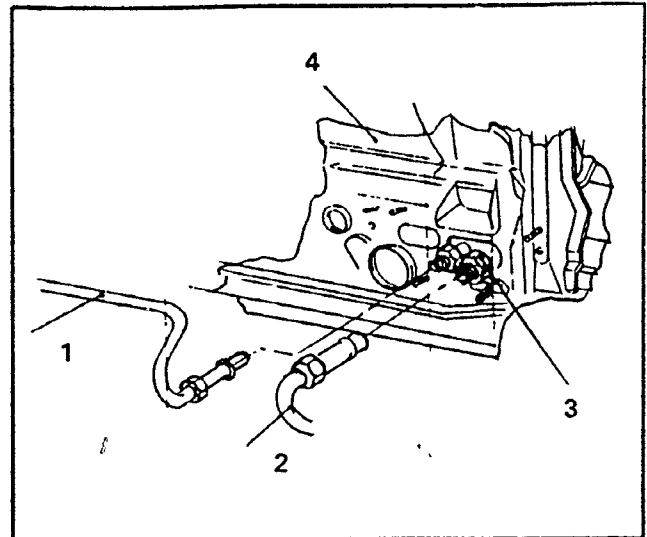


Fig. 33

## REMOVE, DISCONNECT

1. Instrument panel upholstery — Section C.
2. Air distribution housing from bulkhead.

Fig. 34 shows vehicle without AC.

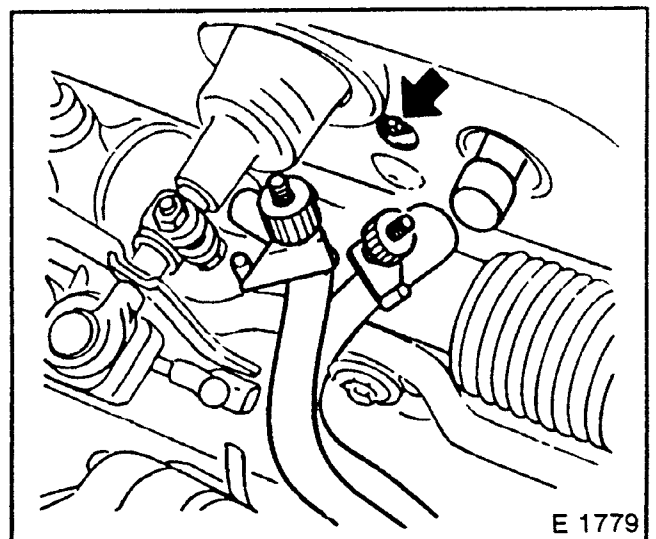


Fig. 34

Fig. 35 shows vehicle with AC.

1. Tube and orifice valve assembly.
2. Evaporator to Accumulator Hose Assembly.
3. Evaporator.
4. Bulkhead Assembly.

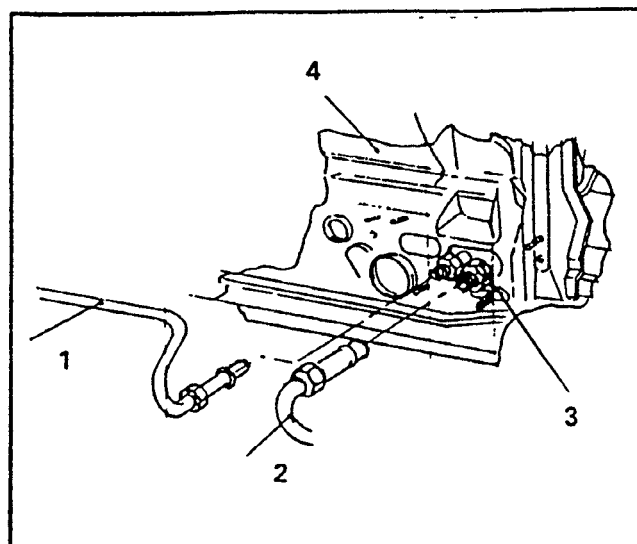


Fig. 35

## REMOVE, DISCONNECT

1. Fan motor wiring harness plug
2. Hose.
3. Clean air filter housing
4. Air distribution housing

## INSTALL, CONNECT

1. Air distribution housing.
2. Lower air distribution housing fastening.
3. Coolant hoses — remove hose clips.  
Feed hose = right  
Return hose = left (to cooling system return flow).
4. Instrument panel upholstery

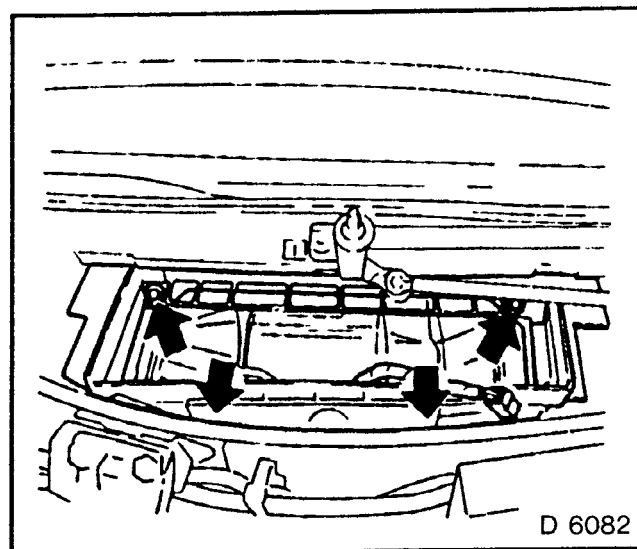


Fig. 36

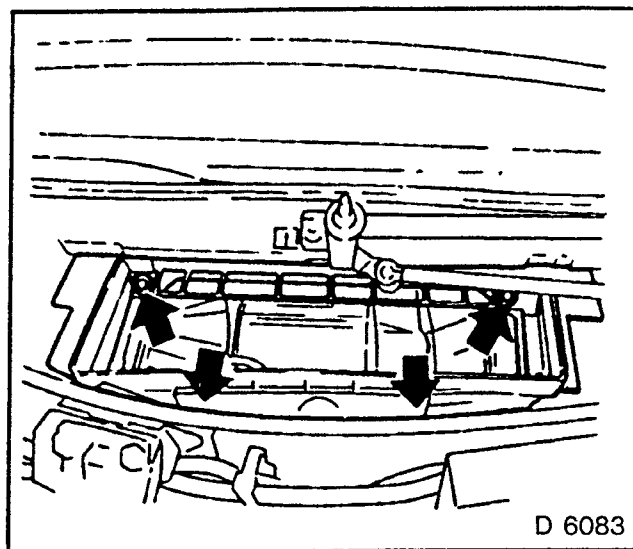
## VEHICLES WITH AIR CONDITIONING:

1. Refrigerant line.
2. Condensation drain hose flange.  
Evacuate and charge AC.
2. Fill up coolant and bleed cooling system  
— Section J.

## Fan Motor — Remove and Install

### REMOVE, DISCONNECT

1. Hose.
2. Clean air filter housing.



D 6083

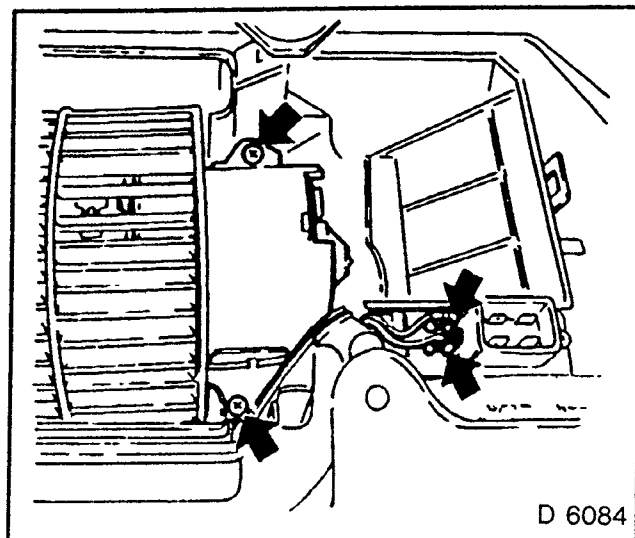
Fig 37

### REMOVE, DISCONNECT

1. Fan housing upper part.
2. Wiring harness plug.
3. Fan motor.

### INSTALL, CONNECT

1. Fan motor.
2. Wiring harness plug.
3. Fan housing upper part.
4. Hose.
5. Clean air filter



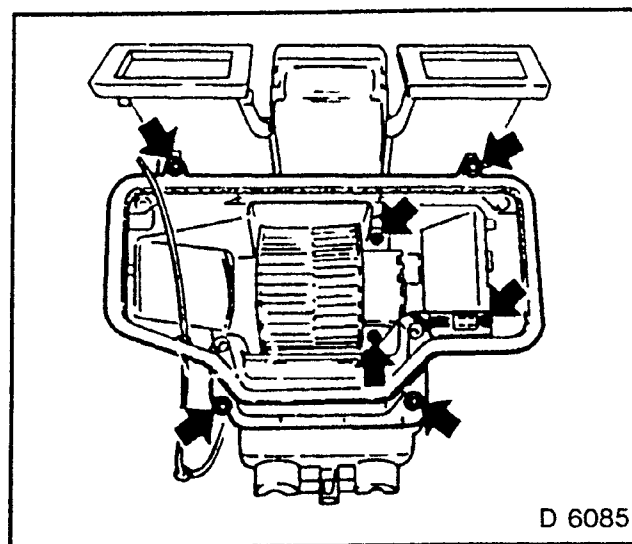
D 6084

Fig 38

## Fan Housing — Remove and Install

### REMOVE, DISCONNECT

1. Air distribution housing
2. Fan housing.
3. Fan motor.
4. Fan motor series resistor.



D 6085

Fig. 39

**INSTALL, CONNECT**

1. Fan motor series resistor.
2. Fan motor.
3. Fan housing.
4. Air distribution housing.

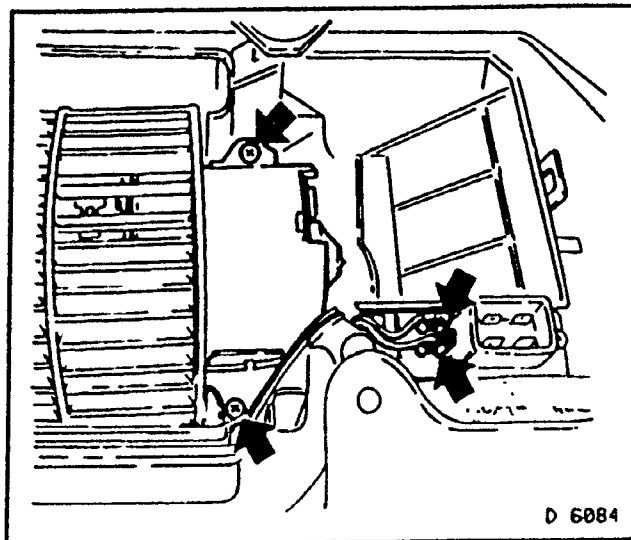


Fig. 40

**Fan Motor Series Resistor — Replace****REMOVE, DISCONNECT**

- 1 Wiring plug
2. Fan motor series resistor.

For clearer representation Fig. 41 shows fan case removed.

**INSTALL, CONNECT**

- 1 Fan motor series resistor — ensure that it engages.
- 2 Wiring plug.

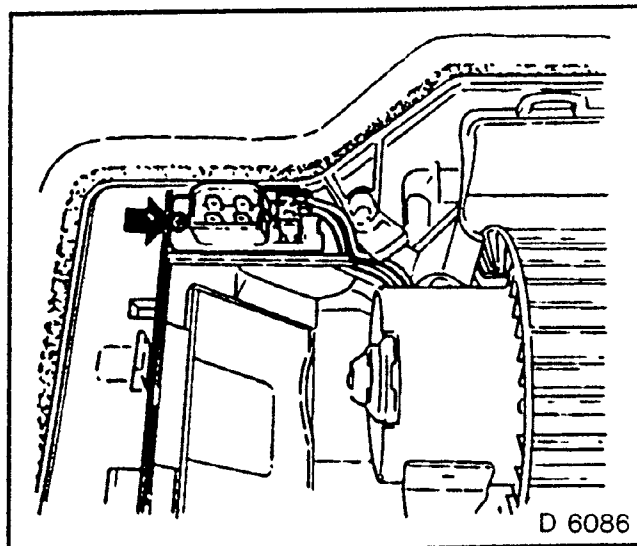


Fig. 41

**Mixed Air/AC Switch — Remove and Install****REMOVE, DISCONNECT**

- 1 Heating operating unit.
- 2 Release wiring harness plug (1) (if present).
- 3 Mixed air/AC switch.

Fig. 42 also applies to vehicles without AC.

**INSTALL, CONNECT**

1. Mixed air/AC switch.
2. Heating operating unit.

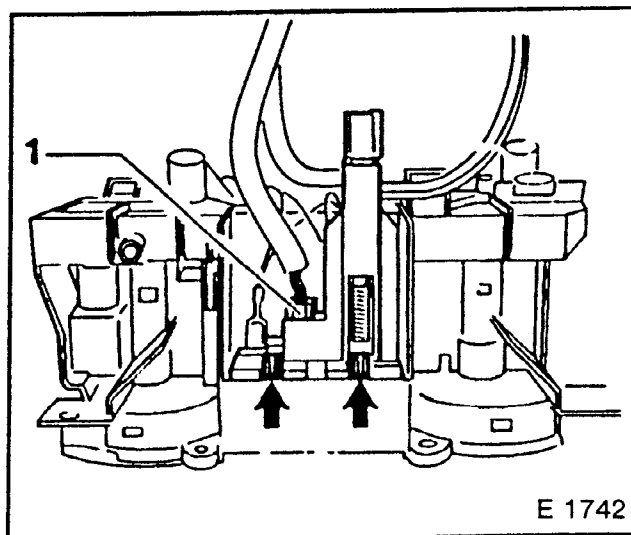


Fig. 42

## Switch for Fan/Heated Rear Screen — Remove and Install

### REMOVE, DISCONNECT

1. Rotary knob — with drift.
2. Unclip switch.

### INSTALL, CONNECT

1. Switch.
2. Rotary knob.

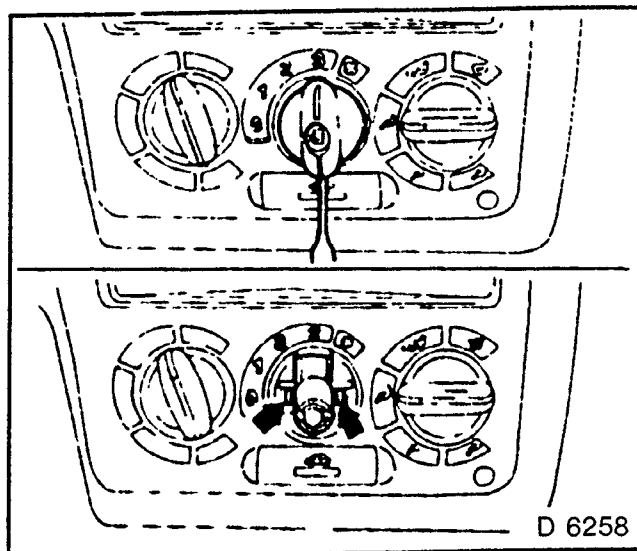


Fig 43

## Mixed Air Actuation Vacuum Unit — Replace

### REMOVE, DISCONNECT

1. Glove compartment — Section C.
2. Unclip actuating rod.
3. Hose.
4. Unclip vacuum unit.

### INSTALL, CONNECT

1. Vacuum unit
2. Hose.
3. Actuating rod
4. Glove compartment.

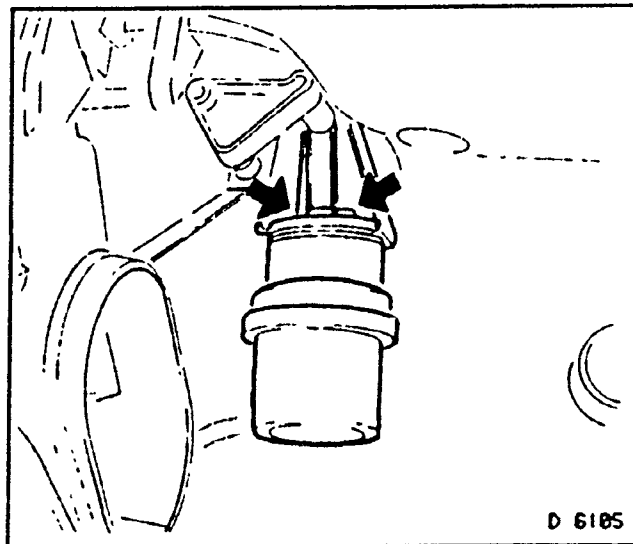


Fig. 44

## AIR CONDITIONING

### General Instructions for the Repair and Storage of Air Conditioning Components

1. Always ensure that connections are closed when storing components of the refrigerant circuit.
2. Attaching parts with missing closures or which have been penetrated by dirt, grease or moisture, should not be installed.
3. Pipes, hoses and individual components may only be installed if the attaching parts are in perfect condition.
4. To equalize temperatures and prevent moisture condensing, these components must be at room temperature.  
Closure caps (plugs) must not be removed until immediately before connection.  
Retain closure plugs from new parts for future repair work.
5. A completely or partially assembled system must not be left unconnected for any longer than is absolutely necessary.
6. The accumulator must not be connected until all other parts of the system have been connected.
7. Use new O-rings from the Parts and Accessories Department range only.
8. Before assembly, O-rings and all pipe and hose connection joints must be lubricated with a small amount of refrigerant oil. See Technical Data.
9. In order to avoid twisting and kinking at the connection, the stationary part must be counterheld when tightening.
10. Connections may only be tightened to the prescribed torque.
11. After repairs on components of the refrigerant circuit, connections must always be checked for leaks using a leak detector.
12. Measure the amount of compressor lubricant in the replaced component.

## Safety Regulations for Handling Refrigerant

**WHEN HANDLING REFRIGERANTS ALWAYS WEAR PROTECTIVE GOGGLES AND GLOVES.** At normal atmospheric pressure and normal ambient temperatures refrigerant evaporates so quickly that if it comes in contact with skin or eyes it can freeze the tissue. If such contact should occur, **RINSE THE AFFECTED PARTS IMMEDIATELY WITH PLENTY OF COLD WATER AND CONSULT A PHYSICIAN IMMEDIATELY.**

### **AVOID SUBJECTING AIR CONDITIONING SYSTEM COMPONENTS TO HEAT:**

- **DO NOT** allow vehicles with an air conditioning system to remain in a drying oven for longer than 20 minutes at 80°C/176°F unless the system has been evacuated.
- When dewaxing a vehicle or steam-cleaning the engine compartment, **NEVER** apply a steam jet directly to the air conditioning system components.

### **WHEN WORKING ON THE REFRIGERANT CIRCUIT, THE WORKPLACE MUST BE WELL VENTILATED.**

Inhalation of highly concentrated refrigerant in the form of gas leads to dizziness and choking sensations.

**WORK ON THE REFRIGERANT CIRCUIT MUST NEVER BE CARRIED OUT FROM A SERVICE PIT.** Gaseous refrigerant is heavier than air and can collect in pits in highly concentrated form.

**WHEN REMOVING SERVICE HOSE CLAMPS, THE HOSE SHOULD NEVER BE POINTED IN ONE'S OWN DIRECTION, AS SMALL AMOUNTS OF REFRIGERANT MAY STILL ESCAPE.**

**REFRIGERANT MUST NOT BE ALLOWED TO COME INTO CONTACT WITH FLAMES OR WITH INCANDESCENT BODIES** (e.g. during welding operations).

**KEEP REFRIGERANT BOTTLES AWAY FROM DIRECT HEAT. NEVER HEAT REFRIGERANT BOTTLES ABOVE 50°C/122°F.**

*The pressure in refrigerant bottles depends on the temperature of the refrigerant. The higher the temperature of the refrigerant, the higher the pressure. If the refrigerant is heated e.g. by sunshine or by another source of heat, excessive pressure can build up, which can cause the bottle to explode.*

**ON VEHICLES WITH AIR CONDITIONING, DEWAXING AND CLEANING OF THE ENGINE WITH STEAM JETS MUST BE CARRIED OUT WITH CAUTION.** On no account must air conditioning components be exposed directly to the steam jet. This would lead to dangerous increases in pressure. The same precautions apply to **WELDING OPERATIONS**. For **PAINTING OPERATIONS** the air conditioning system must be drained before beginning work if the vehicle is to stay in the drying oven for more than 20 minutes at 80°C/176°F. **DO NOT OVER-FILL REFRIGERANT BOTTLES.**

# Air Conditioning Arrangement

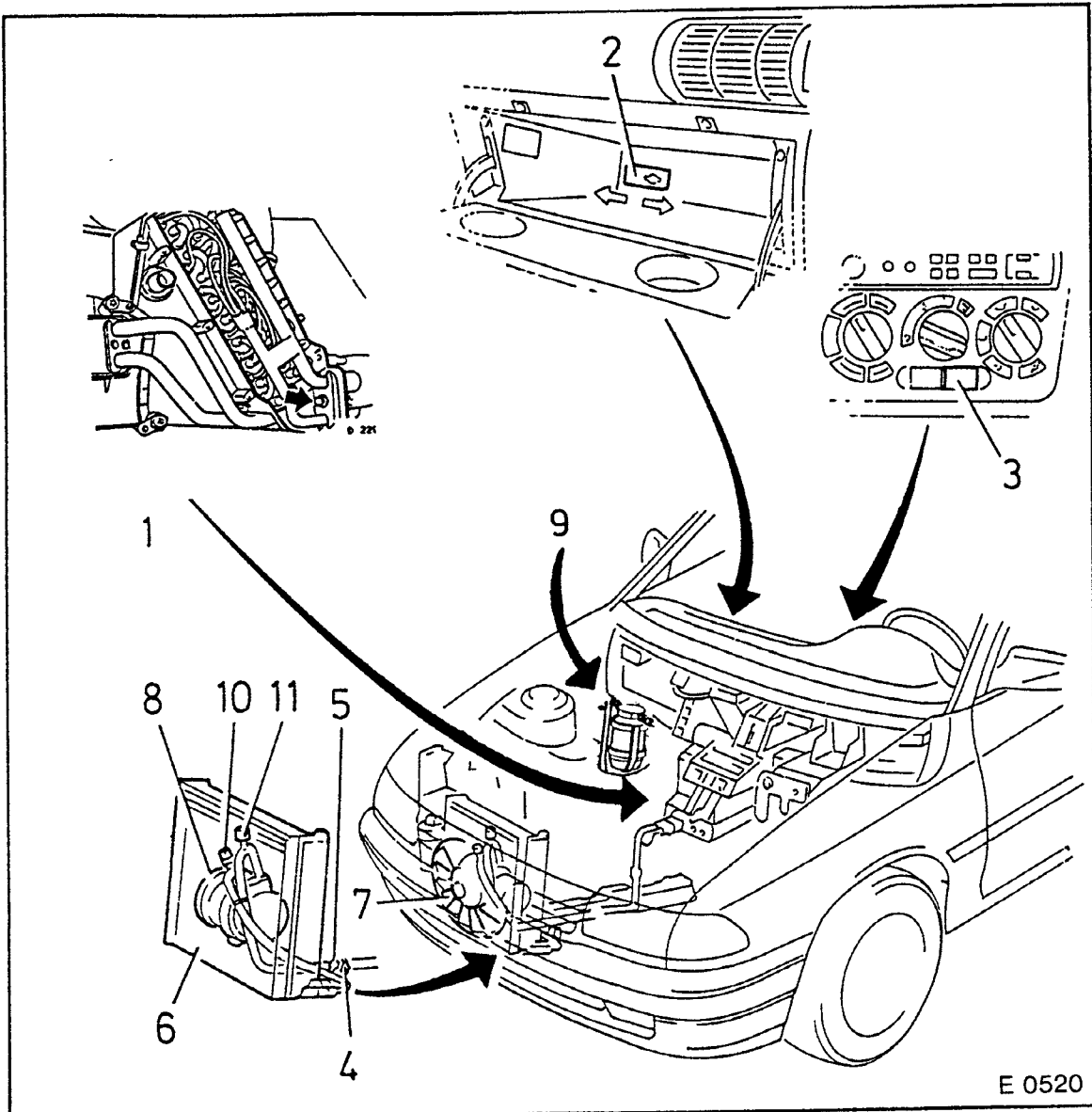


Fig 46

- 1 — Evaporator
- 2 — Glove compartment refrigeration sliding control
- 3 — Air conditioning switch
- 4 — Triple switch
- 5 — Motronic switch
- 6 — Condenser

- 7 — Booster fan
- 8 — Compressor
- 9 — Accumulator
- 10 — High pressure service connection
- 11 — Low pressure service connection



# Air Distribution in Vehicle

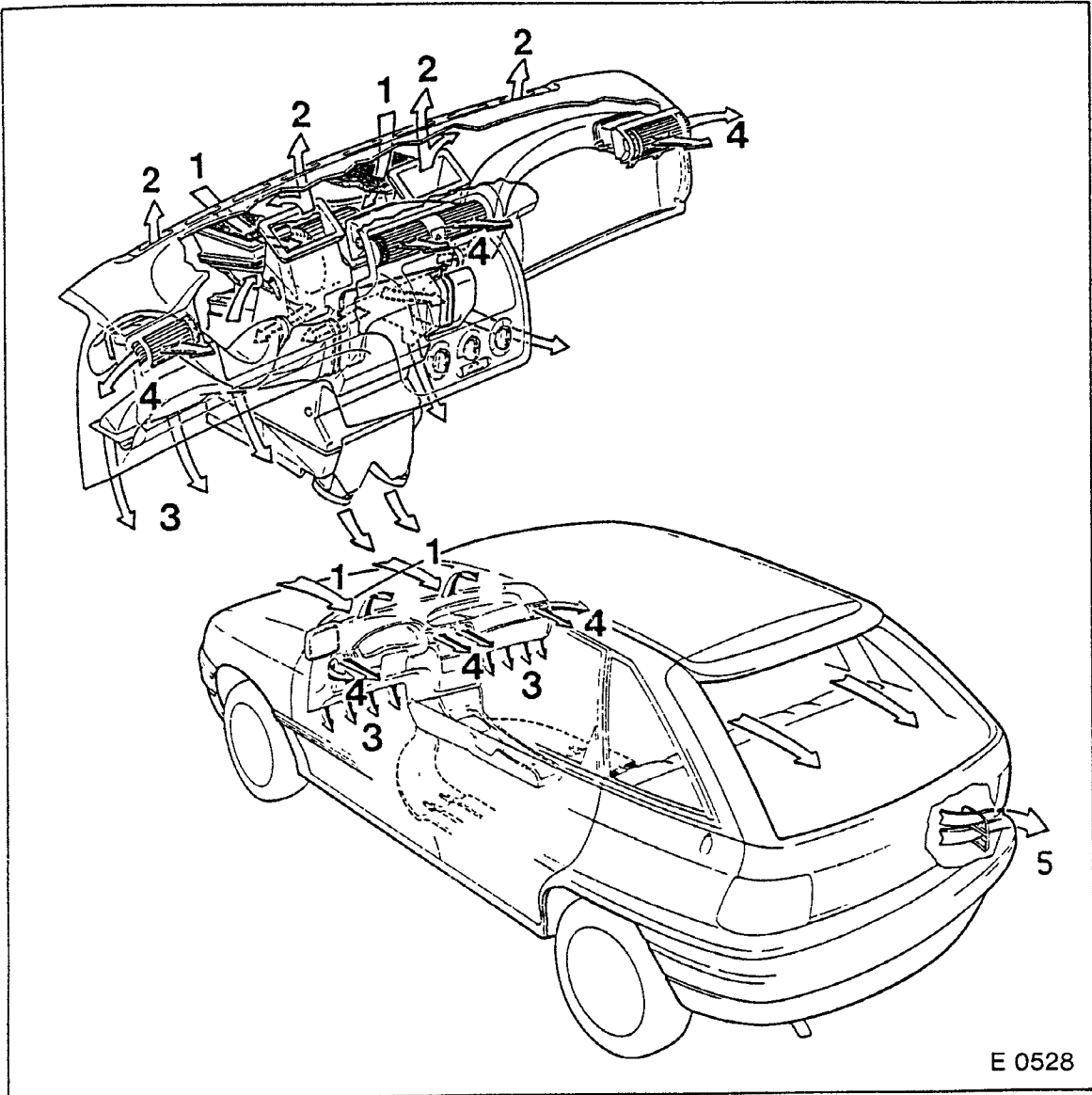


Fig. 47

- 1 — Fresh air intake via fan case
- 2 — Air outlet — windscreen ventilation
- 3 — Air outlet — front footwell ventilation
- 4 — Air outlet — instrument panel
- 5 — Air outlet from vehicle

### OPERATING CONTROLS

The air conditioning system is switched on via the Air Conditioning switch (5) (switch telltale illuminates). The fan operates at stage 1, but this can be increased by turning the switch clockwise.

- 1 Temperature switch
- 2 Fan switch
- 3 Air distribution switch
- 4 Recirculating air switch
- 5 Air Conditioner switch

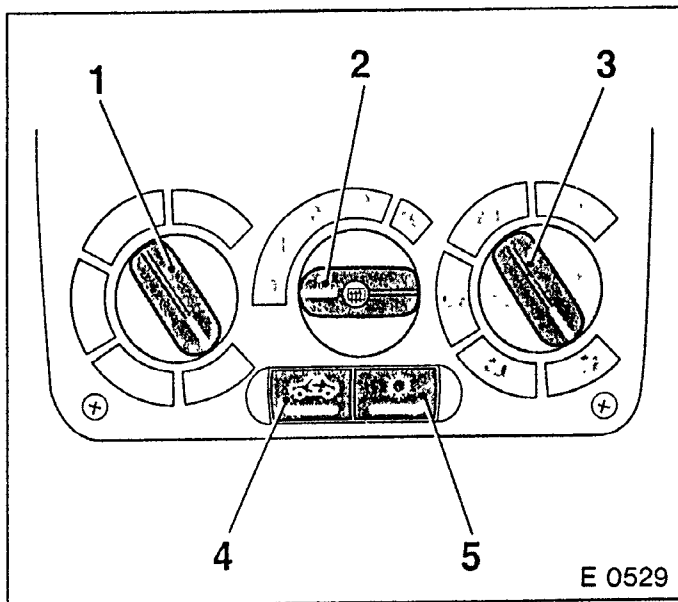


Fig 48

### ADJUSTING THE COOLING FUNCTIONS

#### MAXIMUM COOLING

If the vehicle has been subjected to prolonged heat and sunshine, open the windows briefly to allow the hot air to escape quickly

Switch on AC switch, recirculating air switch, temperature switch to left ("cold"), fan switch to highest stage, air distribution switch to "head level" and open all nozzles.

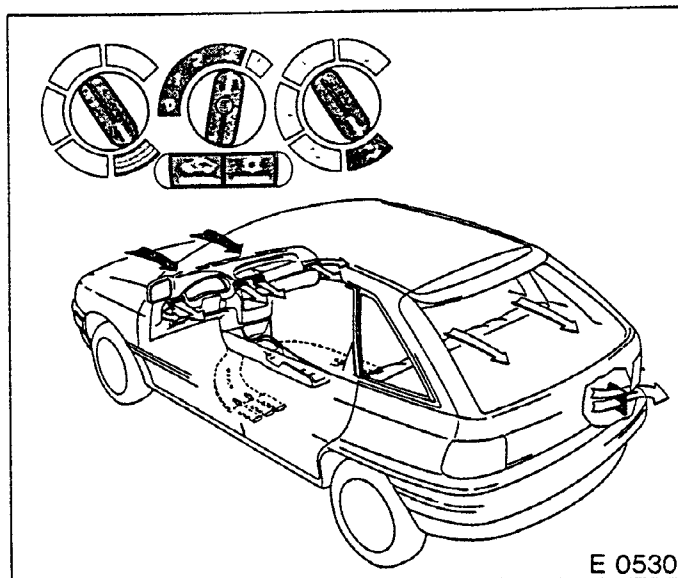


Fig. 49

#### NORMAL COOLING

Press AC switch on, recirculating air switch off, temperature switch to left ("cold"), set fan switch to stage required, air distribution switch to "head level" and open all nozzles.

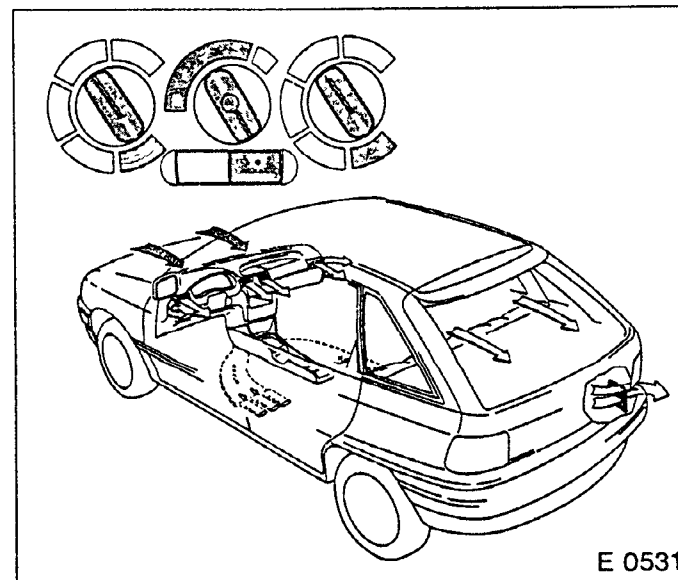
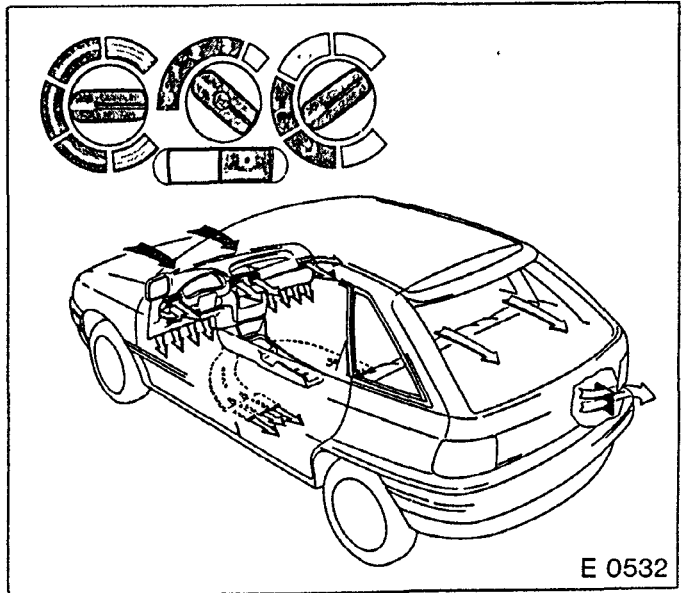


Fig 50

### AIR COOLING WITH TEMPERATURE LEVELS

Press AC switch on, recirculating air switch off, temperature switch as required\*, set fan switch to level required, air distribution switch to head/foot level or to footwell and open nozzles as required.

\*Warm air flows to front footwell and to the side ventilation nozzles, cooler air from the centre nozzles.



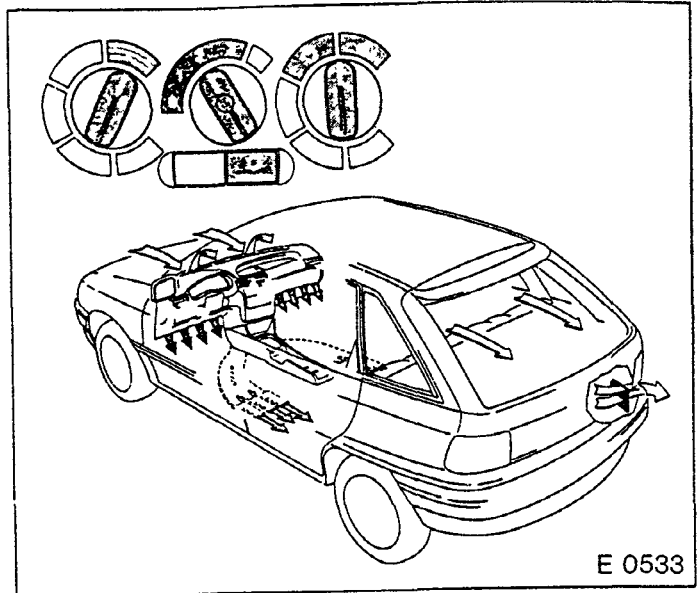
E 0532

Fig. 51

### DEMISTING AND DE-ICING WINDOW PANES

Switch on AC (to speed up demisting, compressor switches on if engine ambient temperature is over +4°C/39°F), temperature switch to right ("warm"), set fan as required, air distribution switch to windscreen or windscreen/front footwell and close all nozzles

**NOTE:**  
IF WINDSCREEN MISTS UP WHEN VEHICLE IS NOT OPERATING AND UNDER CERTAIN WEATHER CONDITIONS, SWITCH ON DEMISTING AND DE-ICING SYSTEM FOR SHORT PERIOD.

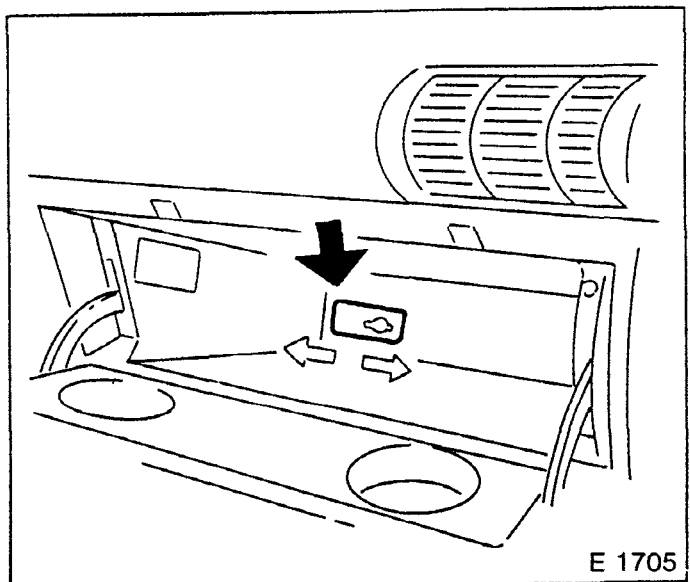


E 0533

Fig. 52

### GLOVE COMPARTMENT REFRIGERATION

When the air conditioning system is switched on, the glove compartment refrigeration can be switched on or off with sliding control.



E 1705

Fig. 53

# Refrigerant Circuit

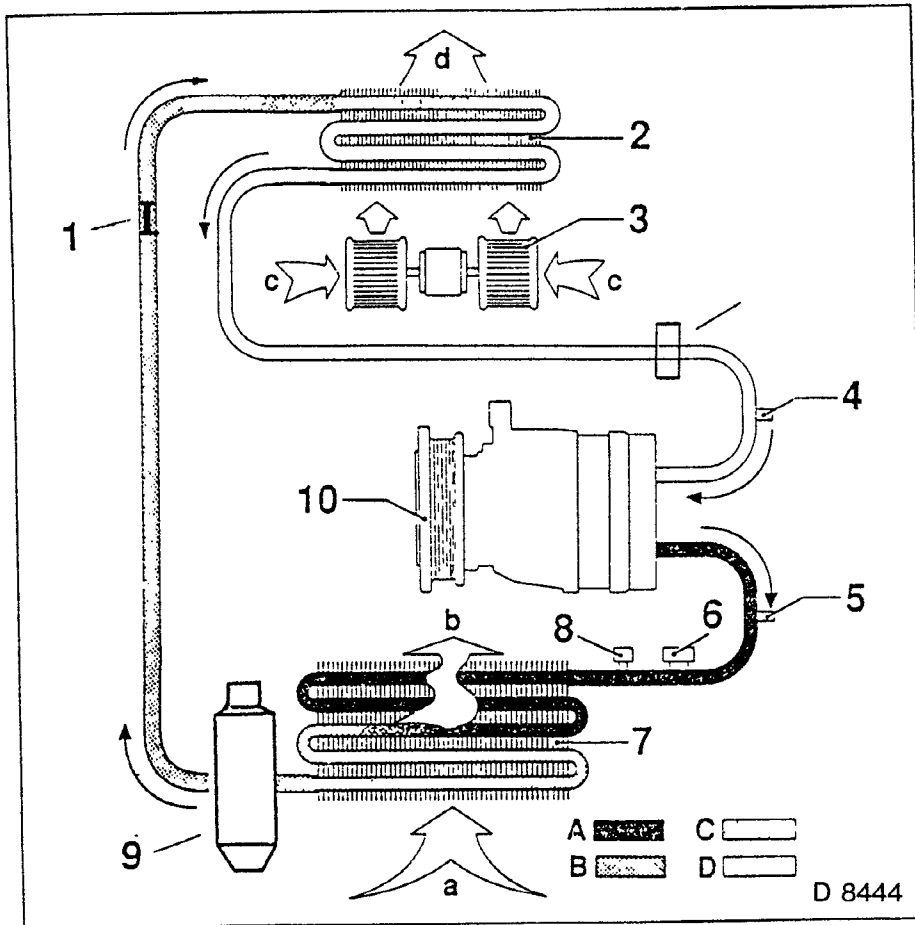


Fig. 54

- 1 — Orifice valve
- 2 — Evaporator
- 3 — Fan
- 4 — Low pressure service connection
- 5 — High pressure service connection
- 6 — Triple switch (low pressure safety, high pressure safety and booster fan)
- 7 — Condenser
- 8 — Motronic switch
- 9 — Accumulator
- 10 — Compressor

- a — Outside air
- b — Warm air
- c — Uncooled air
- d — Cooled air

- A — High pressure vapour
- B — High pressure liquid
- C — Low pressure liquid
- D — Low pressure vapour

D 8444

## Description of Refrigerant Circuit

The compressor (1) sucks low pressure and temperature refrigerant vapour out of the evaporator (2) and compresses this vapour to a high pressure and temperature.

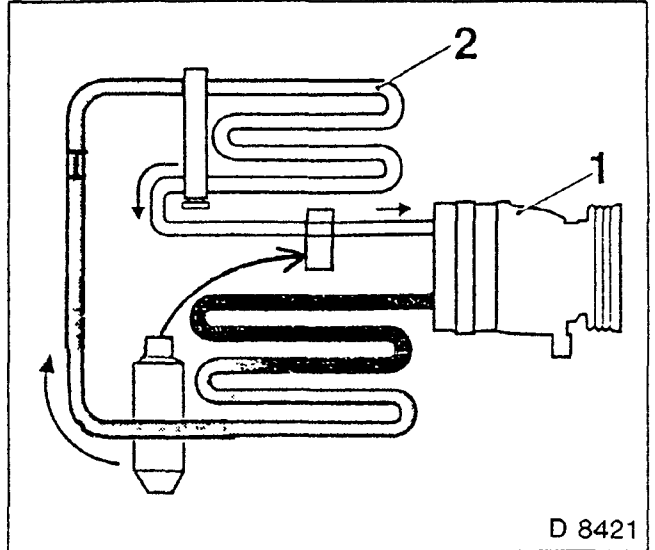


Fig. 55

The compressor (1) compresses the hot refrigerant vapour into the condenser (3). The colder outside air causes the temperature of the hot refrigerant vapour in the condenser to fall below boiling point and the vapour condenses to liquid.

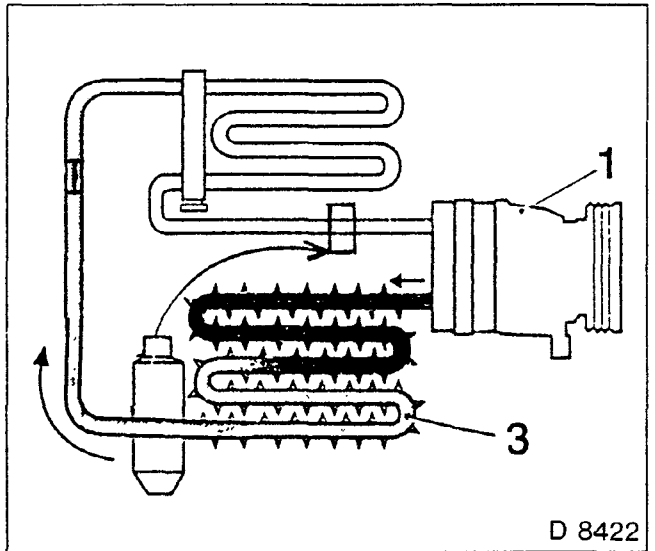


Fig. 56

The liquid refrigerant flows from the condenser (3) to the orifice valve (4).

The orifice valve restricts the diameter of the tube and forms the interface between the high and low pressure phases of the refrigerant circuit.

Finally the refrigerant reaches the evaporator (2). The lower pressure in the evaporator causes the refrigerant to turn to vapour. In doing so it extracts the heat from the immediate environment and the air passing through the evaporator is cooled. The refrigerant is then sucked back into the compressor.

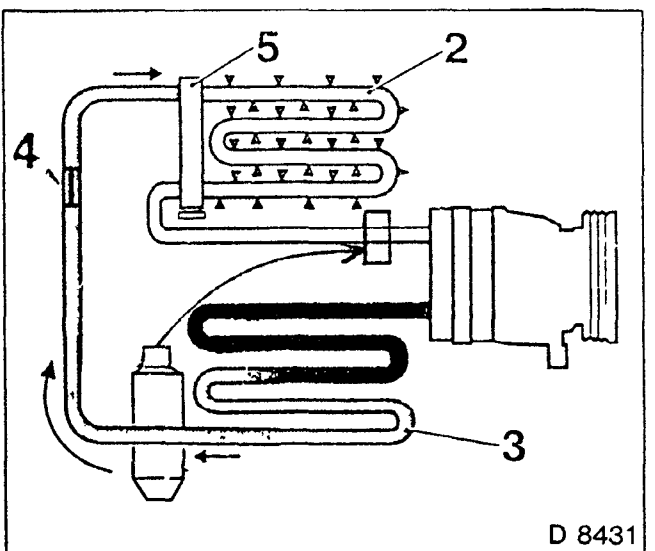


Fig. 57

## Compressor

The compressor sucks the refrigerant vapour out of the evaporator and compresses it to a higher pressure. In the process the temperature of the refrigerant vapour rises.

The compressor is attached to the engine and is driven by a ribbed V-belt with automatic tensioner.

The positive engagement between crankshaft pulley and compressor is via a magnetic coupling.

- 1 — Marker
- 2 — Pressure relief valve
- 3 — Fluid drain plug
- 4 — Magnetic coupling plug contact
- 5 — Pulley with magnetic coupling
- 6 — Outlet to condenser
- 7 — Inlet from evaporator
- 8 — Control valve

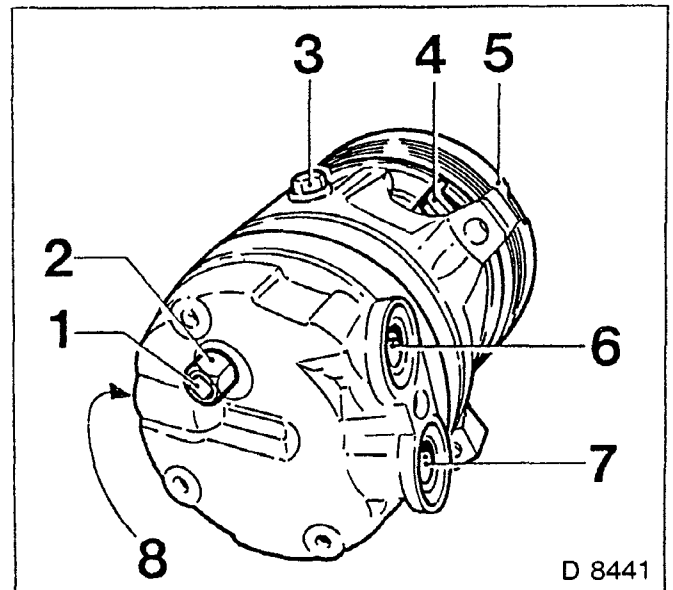


Fig. 58

## SERVICE

When storing the compressor, ensure that all connection points are closed so that no moisture or dirt can enter. They should not be opened until immediately before installation.

The pressure relief valve is equipped with a sticker that serves as a marker. If the marker is missing, this is a sign that refrigerant has escaped via the valve.

The only service operations that should be performed on the compressor are replacement of the control valve, pressure relief valve and the pulley/magnetic coupling assembly. When installing the assembly, the gap (1) between pulley and magnetic coupling must be correct. The gap (1) should not exceed 0.4 to 1.0 mm.

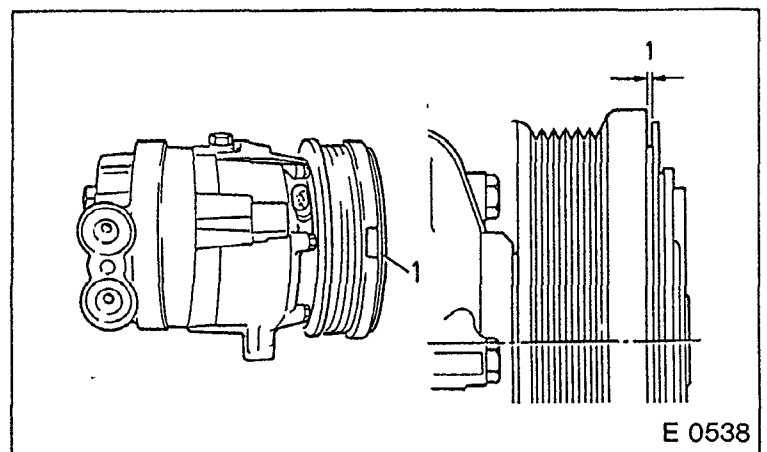


Fig. 59

**CIRCUIT DIAGRAM —  
COMPRESSOR**

- K 6 Air conditioning relay
- K 26 Cooler fan relay
- K 60 Compressor relay
- K 90 Relay in conjunction with automatic transmission
  
- S 20 Triple switch
- S 20-1 Compressor low pressure switch
- S 20-2 Compressor high pressure switch
- S 20-3 Booster fan switch
- S 101 Compressor switch
- S 109 Compressor Motronic switch
- S 128 Coolant temperature switch
  
- V 8 Compressor diode
- Y 1 Compressor coupling

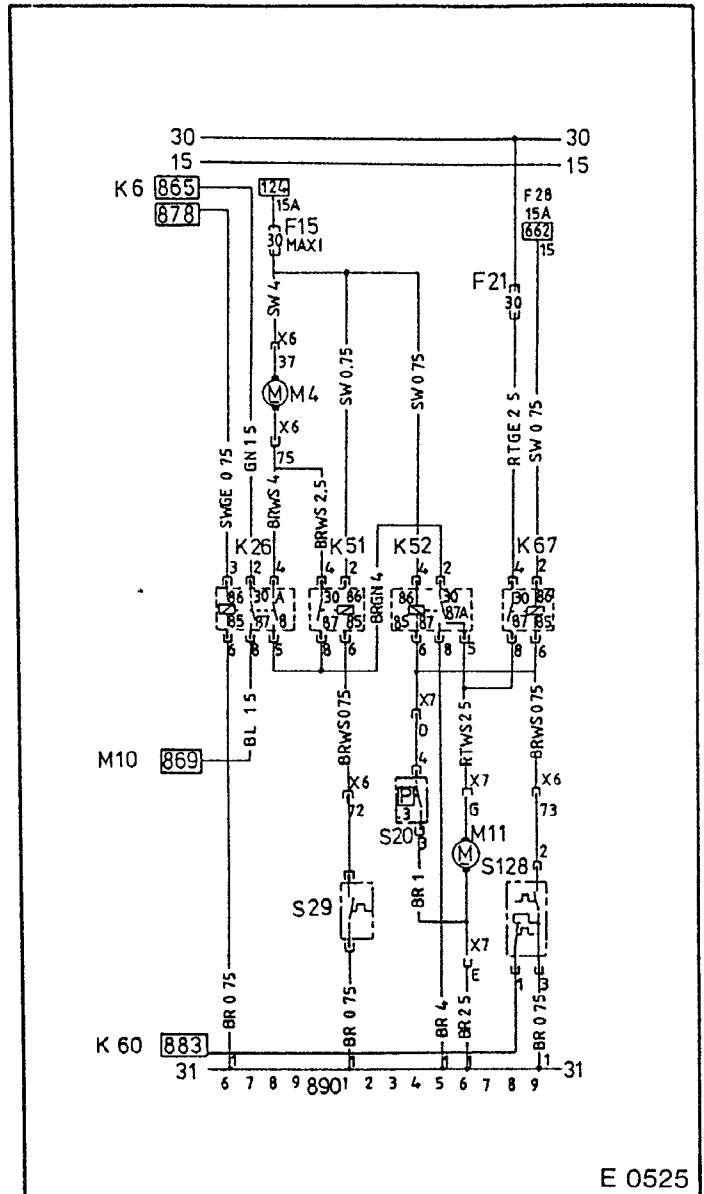


Fig. 60

E 0525

## COMPRESSOR LUBRICANT

The compressor lubricant lubricates the moving parts of the compressor. It is a BVM oil, specially chosen to harmonise with refrigerant R-12a. This special oil circulates along with the refrigerant throughout the entire refrigerant circuit.

The compressor is filled with the full complement of compressor lubricant (approximately 300 ml) before initial operation of the air conditioning system begins. When the system starts to function, the refrigerant carries the lubricant with it through the refrigerant circuit. When the system comes to rest, the lubricant is distributed proportionally throughout the various components.

### Compressor Lubricant — Top up

- See compressor lubricant and total capacity as indicated on page 71, Technical Data.
- The total amount of compressor lubricant to be topped up is composed of the amount in the parts being replaced and of the amount that escapes while the air conditioning is being drained. This amount of new compressor lubricant is filled directly into the component on installation.
- New compressors are filled with the amount of compressor lubricant required for the entire refrigerant circuit.
- When replacing the compressor, first measure the amount of compressor lubricant in the old compressor
- Drain the compressor lubricant from the new compressor into a clean container. Fill the new compressor with the amount of lubricant that was in the old compressor.

### DESIGN OF COMPRESSOR

The compressor has five cylinders with variable stroke. The compressor control valve regulates displacement which determines refrigerant flow.

When the compressor load is increased, the flow of refrigerant is reduced by means of a by-pass, preventing damage due to overloading.

- 1 — Piston
- 2 — Wobble disc
- 3 — Magnetic coupling connection
- 4 — Magnetic coupling
- 5 — Drive shaft
- 6 — Pulley
- 7 — Guide ball
- 8 — Guide rod
- 9 — Control valve
- 10 — Valve plate

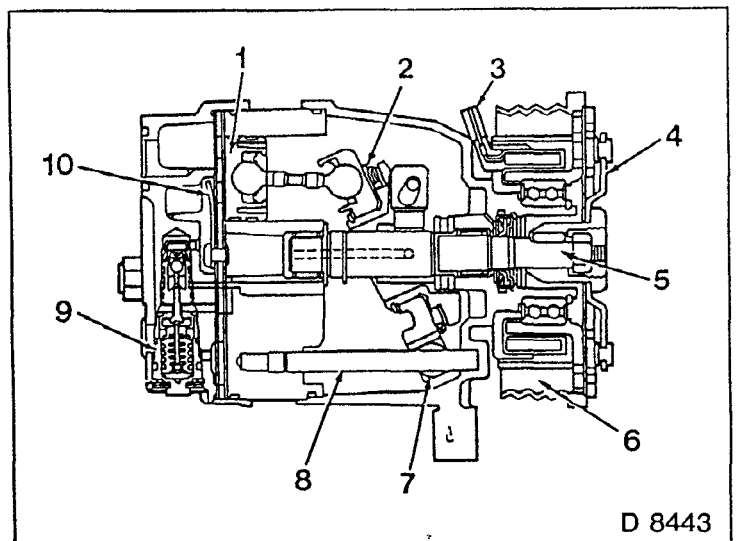


Fig. 61



## DISPLACEMENT VARIATION

The wobble disc activates all five pistons, which are axially arranged. It is installed in a shell bearing and swivels on one side. At the opposite side it moves along a guide rod.

When the compressor is switched on, the swivel mechanism does not operate. The drive shaft causes the centre of the wobble disc to rotate.

When the wobble disc is at almost right angles to its bearings, the plate wobbles only slightly, the piston stroke is at minimum and there is hardly any refrigerant flow.

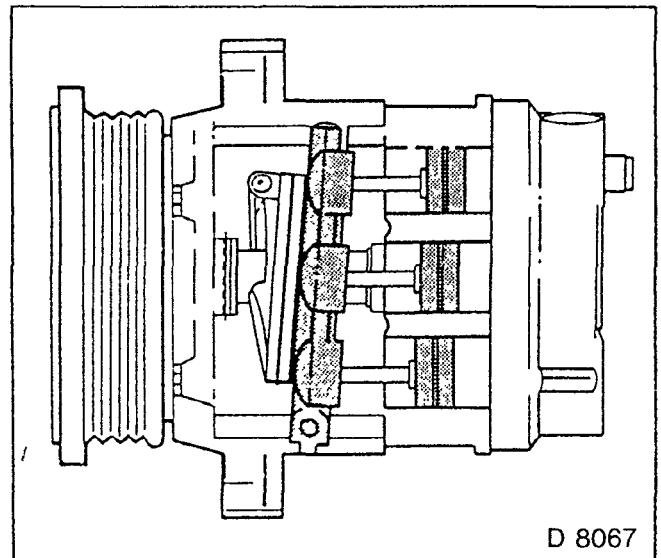


Fig. 62

If the wobble disc is at maximum, the plate wobbles more vigorously, the piston stroke is greater and the flow capacity of the compressor reaches maximum

The high pressure of the refrigerant circuit is exerted at the piston face. The internal pressure of the compressor housing is exerted on the piston base. This internal pressure is controlled by the control valve.

As soon as the relationship of these two pressures changes, the pistons move in the direction of the lower pressure. As the pistons and the wobble disc are connected, the attack angle that the wobble disc takes up varies until both pressures are equal.

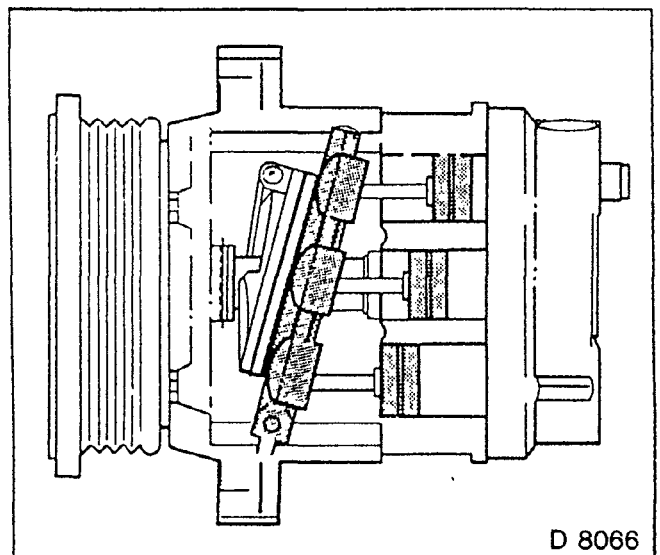


Fig. 63

### PERFORMANCE CONTROL AND FUNCTIONING OF CONTROL VALVE

The control valve regulates the performance of the AC system, ensuring that the system always operates with the greatest possible efficiency. This control is necessary in order to ensure that variable engine speeds and outside temperatures do not lead to variable quality in the air conditioning system and to avoid icing of the evaporator. The temperature of the intake air into the passenger compartment is regulated simply by mixing uncooled air via the temperature switch.

As the pressure on the high pressure side of the refrigerant circuit is almost constant, the force exerted on the piston face side remains nearly constant as well. Only by changing the counterforce on the piston floor, by increasing or reducing the internal pressure of the housing, can the attack angle be changed.

The internal pressure of the compressor housing is controlled by the control valve. The control valve is located on the rear of the compressor.

There is a metal diaphragm (5) with vacuum in the valve and is effected by the pressure on the low pressure side of the refrigerant circuit.

High pressure on the low pressure side compresses the diaphragm, while low pressure causes it to expand. The contraction and expansion of the diaphragm affects the valve ball (2) and the valve constriction (4). Both are joined by the valve stem (3) and are either opened or closed by the pressure of the spring (1) or the counterpressure of the diaphragm.

In this way the valve ball regulates the increase and the valve constriction the decrease in the internal pressure of the compressor housing

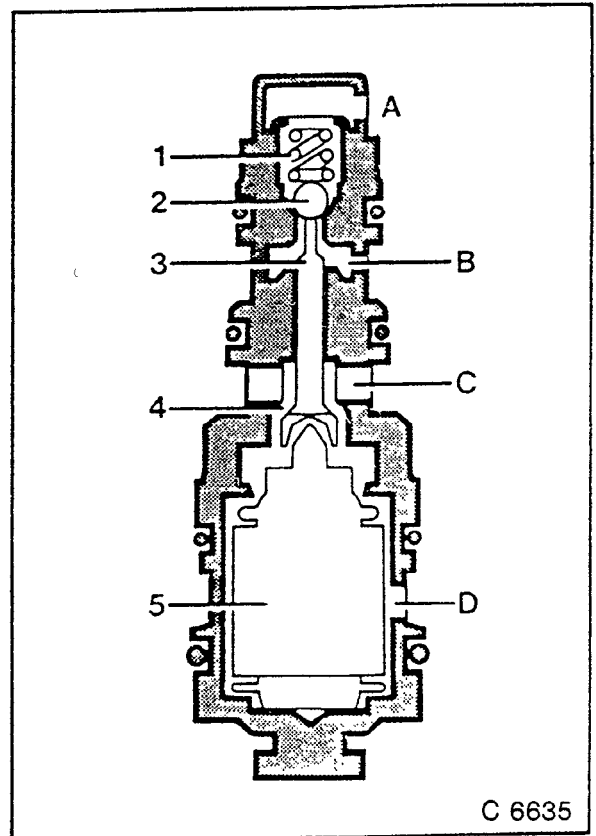


Fig 64

- 1 — Spring
- 2 — Valve ball
- 3 — Valve stem
- 4 — Valve constriction
- 5 — Diaphragm
- A — Pressure from high pressure side
- B — Outlet to compressor interior
- C — Inlet from compressor interior
- D — Outlet to low pressure side

For performance control the following are important:

### 1. HIGH PERFORMANCE REQUIREMENT

High pressure on the low pressure side affects the diaphragm. This contracts and causes the ball valve to close the delivery of high pressure and at the same time open the valve constriction. The refrigerant in the compressor housing can move to the suction side and the internal pressure of the housing is reduced. The attack angle of the wobble disc is enlarged and the piston stroke increased.

Compressor displacement is regulated to give maximum performance.

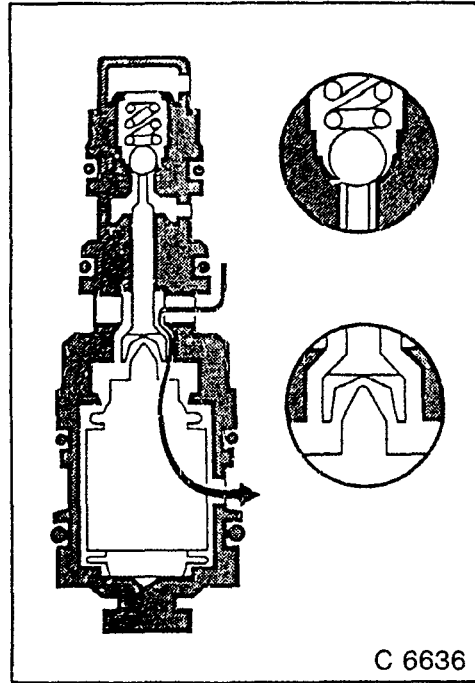


Fig. 65

### 2. LOW PERFORMANCE REQUIREMENT

Low pressure on the low pressure side affects the diaphragm. This expands and the valve constriction is closed. Refrigerant vapour cannot move to the suction side from the compressor housing. The valve ball clears the way for delivery of high pressure refrigerant and the internal pressure of the housing is increased. The attack angle of the wobble disc becomes narrower and piston stroke is reduced.

The compressor operates with minimum displacement and minimum performance.

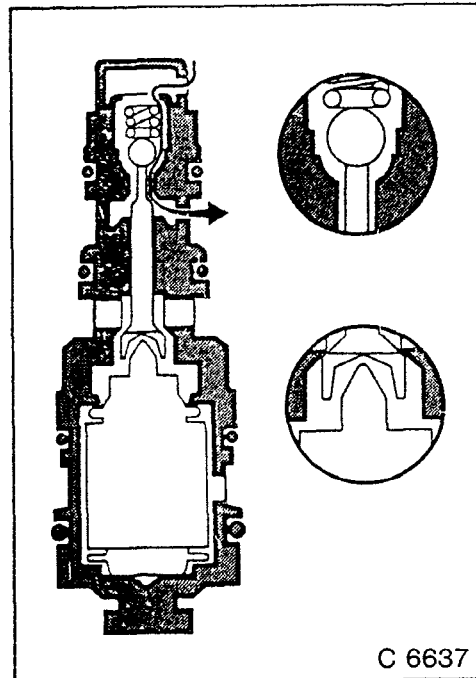


Fig 66

### SERVICE

When installing the valve, always use new O-rings. Coat the O-rings with mineral oil.

**NEVER USE COMPRESSOR LUBRICANT FOR THIS PURPOSE.**

## Condenser

The condenser cools the hot refrigerant vapour and condenses it to liquid refrigerant.

The condenser is made up of a continuous aluminium tube connected by plates that act as intensive heat conductors. Temperatures in the condenser reach up to 100°C/212°F.

Due to this additional source of heat and the location of the condenser in front of the vehicle's radiator, the volume of circulating air is reduced and the engine's cooling system affected. A heavy duty radiator and an extra electric fan at the front of the condenser guarantee adequate cooling of both condenser and engine.

The pressure in the condenser is between 800 and 3 000 kPa (8 and 30 bar).

### SERVICE

Always store a condenser with all connecting points closed to prevent moisture and dirt from entering. **DO NOT** remove the stoppers until immediately before installation.

A new condenser is filled with nitrogen to prevent corrosion. When the stoppers are being removed, the nitrogen can be heard to escape due to slight excess pressure.

## Accumulator

The accumulator has two functions.

During service operations that involve opening the refrigerant circuit, small amounts of moisture enter the system. The drier contained in the accumulator absorbs the moisture from the refrigerant, as this could lead to malfunction of the air conditioning system.

The accumulator also filters out residual gaseous refrigerant particles which might adversely affect the orifice valve.

The accumulator is located on the low pressure side of the refrigerant circuit near to the evaporator

### OPERATION OF HARRISON ACCUMULATOR/DEHYDRATOR

A mixture of refrigerant liquid and vapour with oil enters the accumulator/dehydrator from the evaporator. A baffle deflects the liquid refrigerant and oil to the bottom of the accumulator/dehydrator. Vapour is drawn from the top of the accumulator/dehydrator through the outlet tube by the compressor. A small opening in the bottom bend of the outlet tube allows a calibrated amount of oil in the refrigerant solution to return to the compressor for lubrication.

### SERVICE

The accumulator does not need servicing, but must be exchanged every time the refrigerant circuit is opened. It should always be stored with closed connecting points to prevent moisture and dirt from entering. Stoppers should not be removed until shortly before installation.

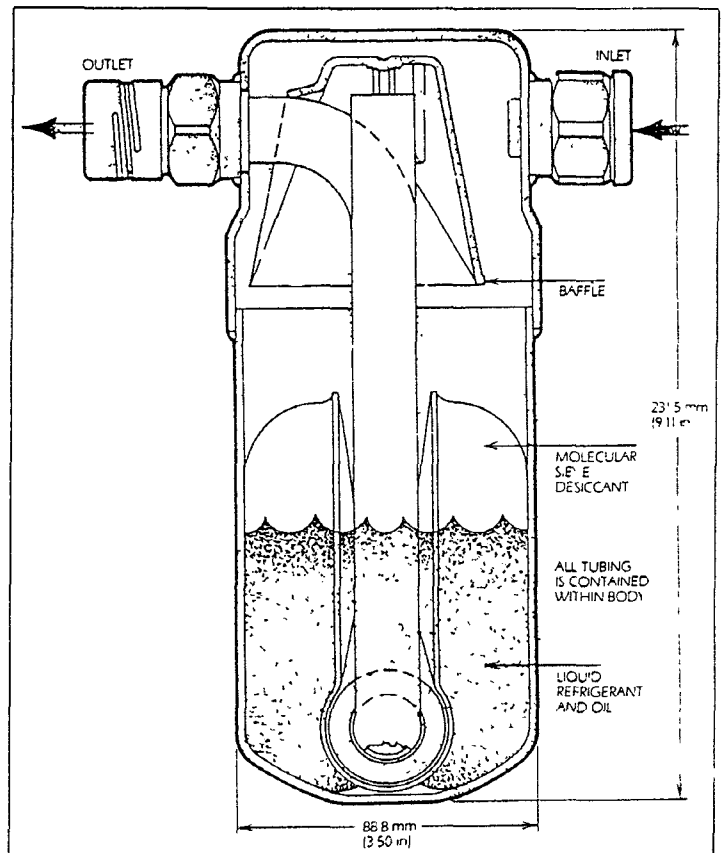


Fig. 67

## Orifice valve

The orifice valve forms the interface between high pressure and low pressure ranges in the refrigerant circuit.

A drop in pressure behind the orifice valve causes the refrigerant to evaporate.

The orifice valve is located between the condenser and the evaporator inlet pipe.

The orifice valve has a calibrated flow diameter.

Location of the orifice valve:

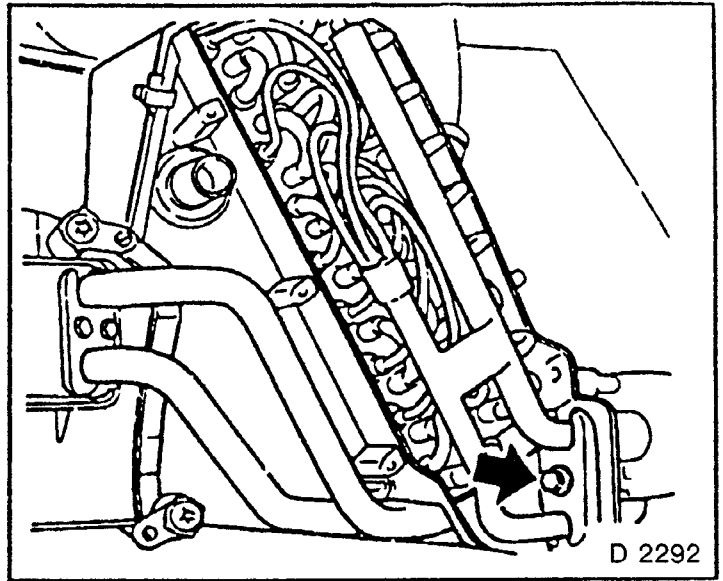


Fig. 68

## Evaporator

As a result of the fall in pressure after passing through the orifice valve, the refrigerant turns to gas in the evaporator and in so doing absorbs heat from the immediate environment.

The evaporator is made of aluminium and like the condenser consists of a series of pipes and plates, installed in the air distributor housing in front of the heater core.

Location of evaporator in air distributor housing:

Fresh air flows over the evaporator plates where it is cooled, dried and purified when the evaporator is switched on.

The air is dried and purified as follows:

The moisture in the fresh air making contact with the plates condenses on the cold surface of the evaporator. Dust, pollen, etc. are trapped by the condensed water and washed out along with the condensed water via the condensation waste hoses.

## SERVICE

When a vehicle's engine is switched off after running for a lengthy period with the air conditioner operating, the condensed water may collect in a puddle under the vehicle.

When storing the evaporator, ensure that all connection points are closed so that no moisture or dirt can enter. They should not be opened until immediately before installation.

A new evaporator is filled with nitrogen to prevent corrosion. When the stoppers are being removed, the nitrogen can be heard to escape due to slight excess pressure.

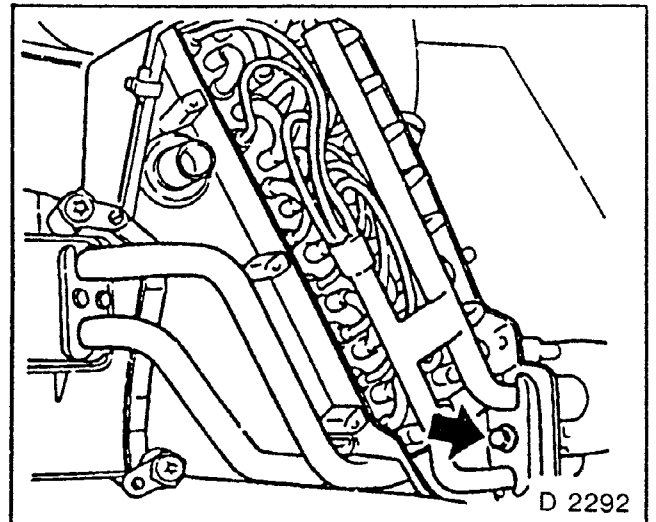


Fig 69

## Air Distribution in Air Distributor Case

The air flow system in vehicles with air conditioning is essentially the same as the system in vehicles with conventional heating and ventilation.

The one component that is essentially different is the evaporator, which is located in the airstream in front of the heater core.

Fresh air is always forced into contact with the evaporator plates before being transported, cooled or not, into the passenger compartment.

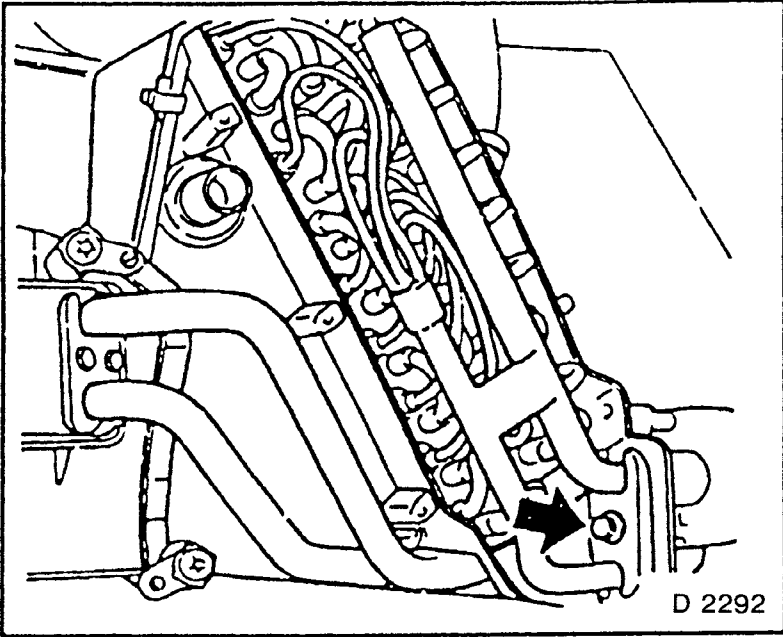


Fig. 70

# Booster Fan

The booster fan augments the cooling of the condenser and the engine.

When the air conditioning system is switched on, the booster fan M 11 and radiator fan M 4 are automatically activated. They are switched in sequence via relay K 26, the voltage is halved and both fans operate at stage 1.

The triggering of booster fan switch S 20-3 or coolant temperature switch S 128 causes booster fan M 11 and radiator fan M 4 to be switched in parallel via relay K 67. The fans receive full battery voltage and operate at stage 2.

When the air conditioning system is switched off, radiator fan switch S 29 switches booster fan M 11 and radiator fan M 4 to stage 1 if the coolant becomes too warm, just as it does in the case of vehicles without air conditioning.

## CIRCUIT DIAGRAM — BOOSTER FAN

- K 6 AC relay
- K 26 Radiator fan relay
- K 51 Radiator fan relay
- K 52 Radiator fan relay
- K 60 Compressor relay
- K 67 Radiator fan relay
- M 4 Radiator fan motor
- M 10 Heating fan motor
- M 11 Radiator booster fan motor
- S 20-3 Booster fan switch
- S 29 Coolant temperature switch
- S 128 Coolant temperature switch

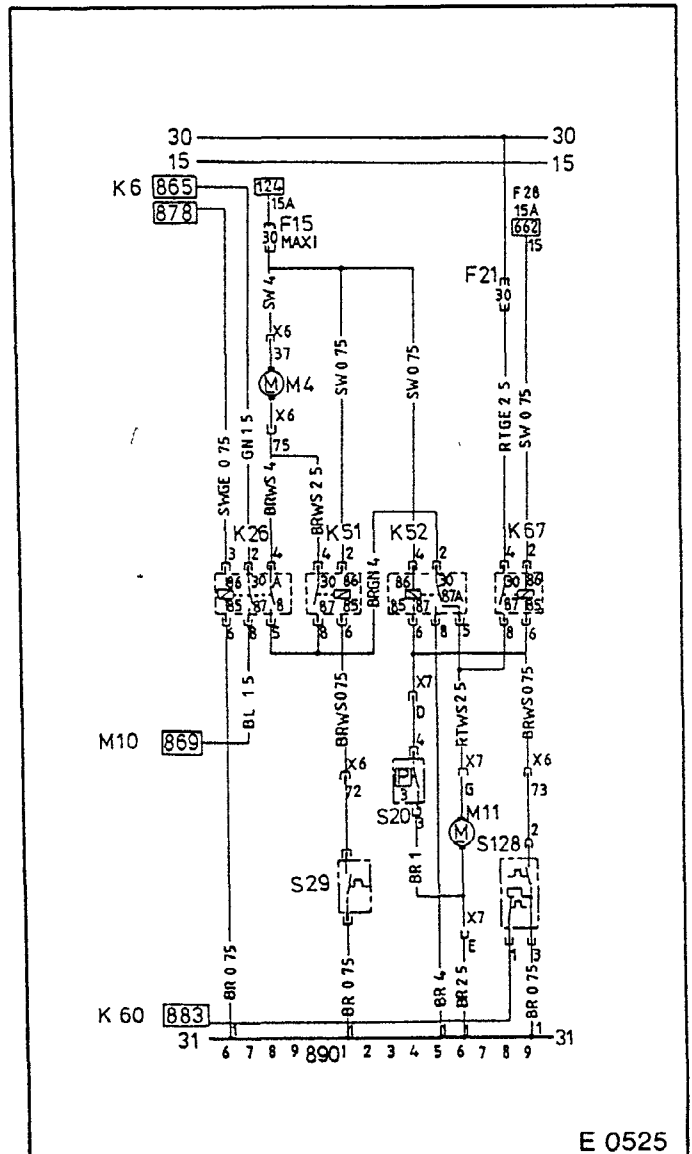


Fig. 71



## SERVICE CONNECTIONS

The AC system is connected to the service station by the service connections.

The service connections are equipped with a Schrader valve of the type used in vehicle tyres.

The service connections have screw-on protective caps, which provide additional sealing for the valve and protect it from dirt and damage. The caps are screwed on by hand.

### Low pressure service connection (1).

The pressure in the low pressure range of the refrigerant circuit can be measured at the low pressure connection. The prescribed value\* is 190 to 210 kPa (1.9 to 2.1 bar).

### High pressure service connection (2).

The pressure in the high pressure range of the refrigerant circuit can be measured at the high pressure connection. The prescribed value\* is 1,000 to 1,800 kPa (10 to 18 bar).

Engine speed approximately 1 500 rpm, AC system on, outside temperature approximately 20°C/68°F

## MOISTURE IN REFRIGERANT CIRCUIT

Moisture in the refrigerant circuit is a frequent cause of malfunction of the AC system. It can lead to corrosion of the compressor interior and to irregular performance of the AC system.

Moisture in the refrigerant may have various causes.

- Humidity in the atmosphere condenses and is deposited on or in exposed AC components while service is being performed.
- Atmospheric humidity is diffused in the refrigerant lines in the closed refrigerant circuit.

Careful storage of the components and evacuation of the system after service operations in most cases, prevents moisture from entering the refrigerant circuit. Residual moisture in the refrigerant is removed by the drier in the accumulator.

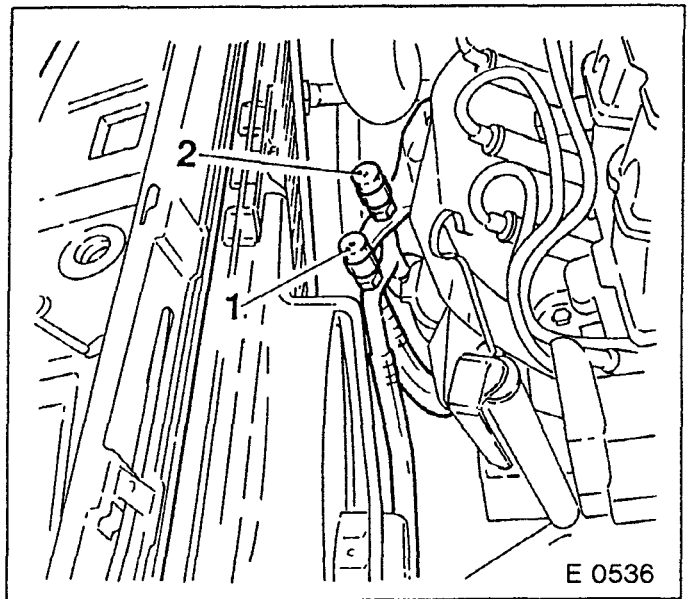


Fig. 72

## Leak Detection in Refrigerant Circuit

Before draining the AC system, the refrigerant circuit must be checked for leaks with the leak detector. If leaks that are present cannot be localised before the system is drained, sealed after draining but before evacuation of the system, air and moisture may enter the system when it is later evacuated.

Leaks in the system occur chiefly at connections. They can be detected in some cases with the naked eye, as the compressor lubricant that escapes combines with dust and dirt from the atmosphere, causing the location of the leak to appear greasy and dirty

- Check connection joints and hoses carefully.
- The vehicle engine should remain switched off when checking for leaks.
- The engine compartment should be well ventilated before checking for leaks with a leak detector as the detector will also react with vapour given off by detergents, antifreeze, fuel, etc
- Movement of air in the engine compartment should be kept to a minimum during leak detection, so that even the minutest leaks can be found.
- When leaks are located, the lower side of the location must be checked in each case, as refrigerant gas is heavier than air.
- The refrigerant circuit must be pressurized for detection of leaks. For this purpose completely drained systems may be filled with approximately 400 g refrigerant.

# Air Conditioning, Drain

## INSPECT

Before the refrigerant circuit is opened for service operations, the system must be drained.

Before draining the air conditioning:

1. Check the leaks at the underside (gas is heavier than air) of all connection points on the refrigerant circuit — Leak Detector Unit W13480
2. If present, seal leaks.

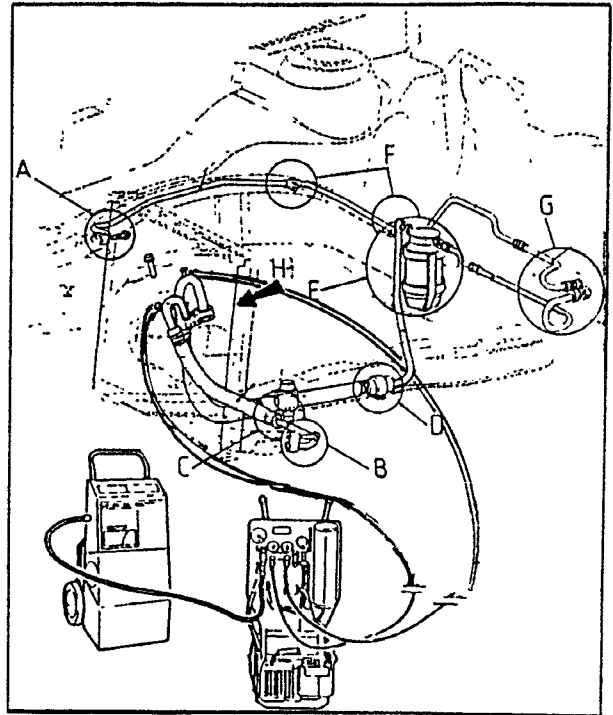


Fig 73

The refrigerant is removed by the service station, recycled and stored. In the draining process some of the compressor lubricant also escapes

Connect Service Station 17351 to AC service connections.

- Red hose to high pressure service connection.
- Blue hose to low pressure service connection.

The service station operating instructions describe how to proceed further.

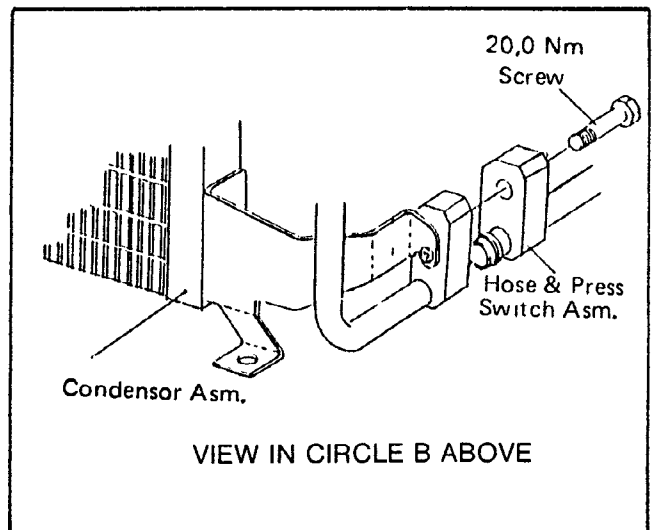
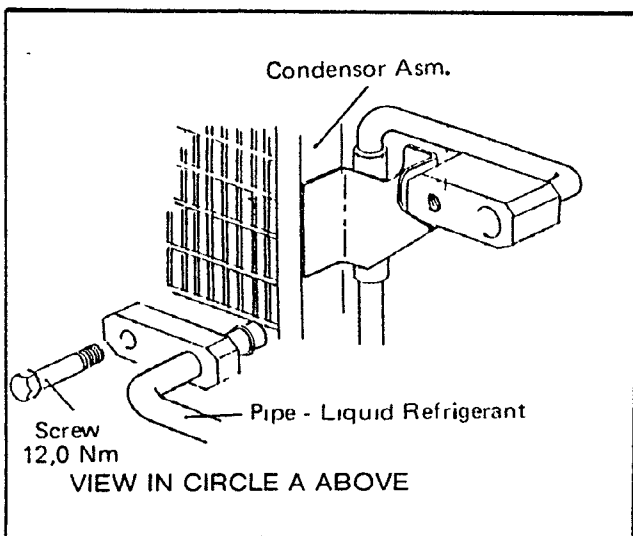


Fig. 74

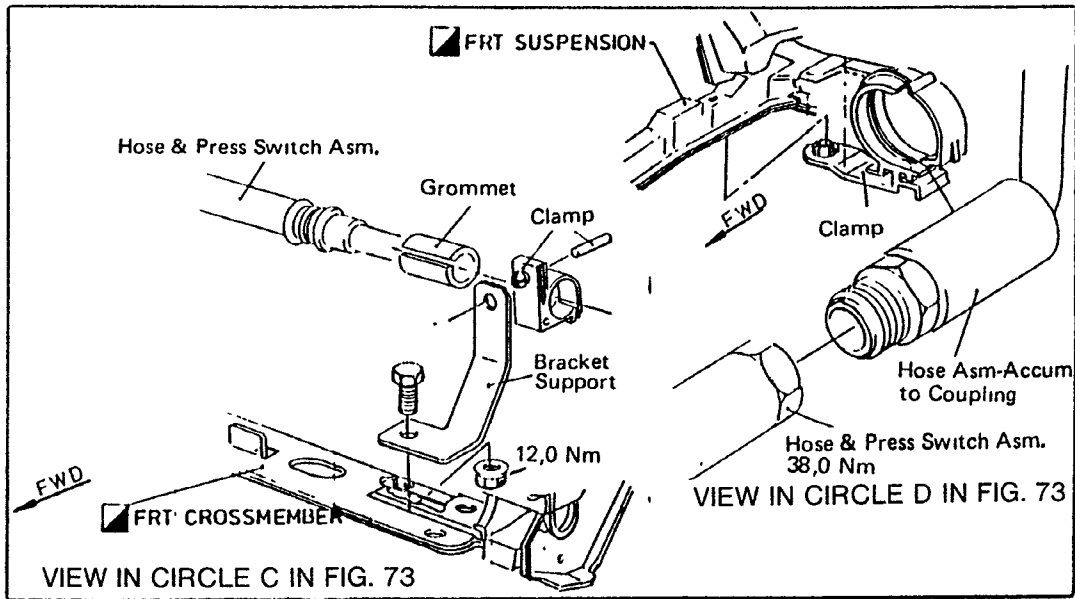


Fig. 75

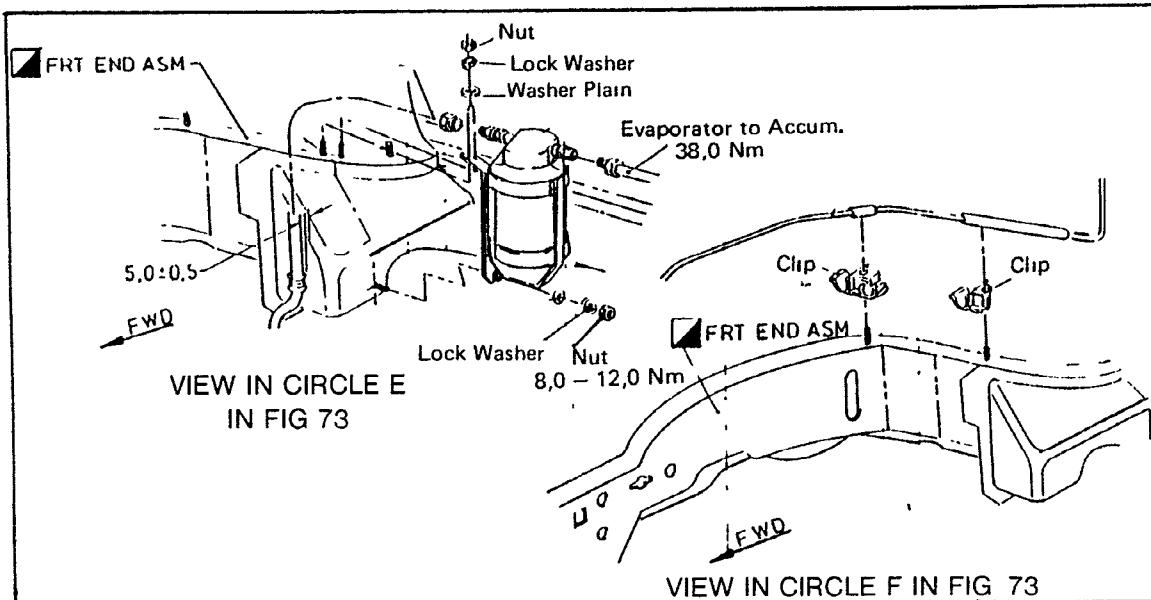


Fig. 76

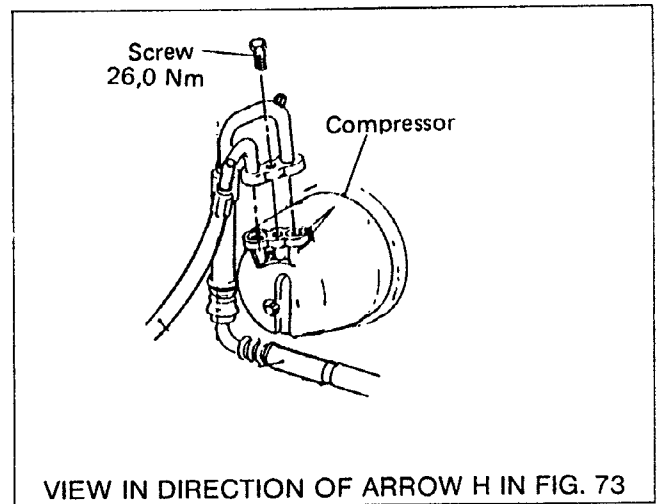
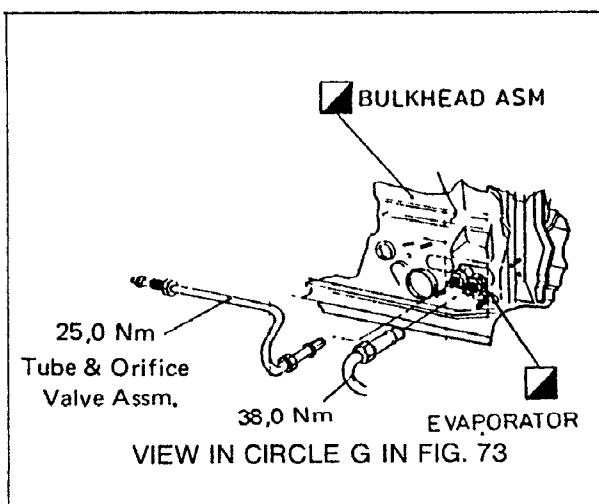


Fig. 77

**INSTALL, CONNECT**

1. Red hose from MKM — 721 to high pressure service connection (B).
2. Blue hose to low pressure service connection (A). (Fig. 78).  
Yellow hose from MKM — 721 to MKM — 720 See arrow — Fig. 79.
3. Drain air conditioning — observe MKM — 720 and MKM — 721 Operating Instructions.

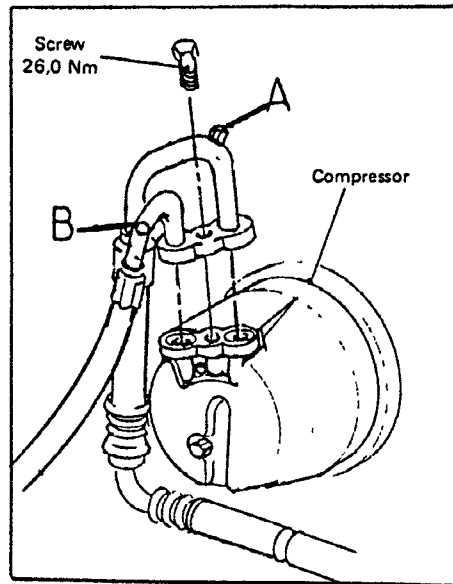


Fig. 78

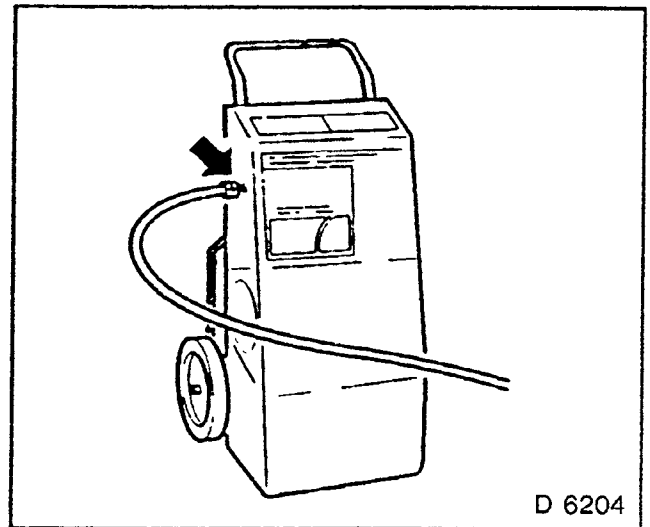
4. Close valve (yellow hose) at service station.
5. Disconnect MKM — 720 from MKM — 721.
6. Read off amount of escaped refrigerant oil in measuring beaker.
7. Refill with same amount of fresh refrigerant oil later.

**WARNING:**

**OPEN AIR CONDITIONING IMMEDIATELY AFTER DRAINING — AS PRESSURE MAY INCREASE DUE TO REMAINING REFRIGERANT IN AIR CONDITIONING.**

**REMOVE, DISCONNECT**

1. MKM — 720 and MKM — 721



D 6204

Fig. 79

## Air Conditioning, Evacuate and Charge

The AC system must be evacuated each time before it is refilled to remove air and moisture from the system.

The boiling point of water rises or falls according to the surrounding pressure. At normal atmospheric pressure of approximately 100 kPa (1.0 bar) its boiling point is 100°C/ 212°F. If the pressure is reduced (evacuation) to approximately 2.3 kPa (0.023 bar) in the AC system, any water contained in the system boils at normal room temperature at 20°C/ 68°F. This is removed as vapour when the service station evacuates the system.

### INSTALL, CONNECT

Red hose from MKM 721 to high pressure service connection (B).

Blue hose to low pressure service connection (A) Fig. 80.

Evacuate air conditioning — observe MKM — 721 Operating instructions.

### INSPECT

1. Check for leaks at the underside (gas is heavier than air) of all connection points on the refrigerant circuit — Leak Detector, Unit W13480.
2. If present, seal leaks.

#### NOTE:

**FOR DETECTION OF LEAKS, APPROXIMATELY 300 GRAMMES REFRIGERANT CAN BE PLACED INTO THE SYSTEM.**

3. Fill Filling Cylinder from MKM — 721 with 900 grammes R 12 refrigerant
4. Charge air conditioning — follow MKM — 721 Operating Instructions.

### REMOVE, DISCONNECT

1. MKM — 721.

### INSPECT

1. Functioning of air conditioning.

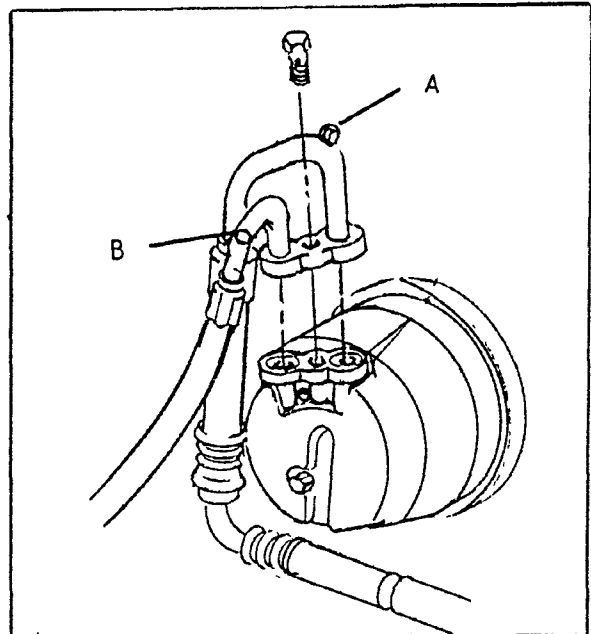


Fig. 80

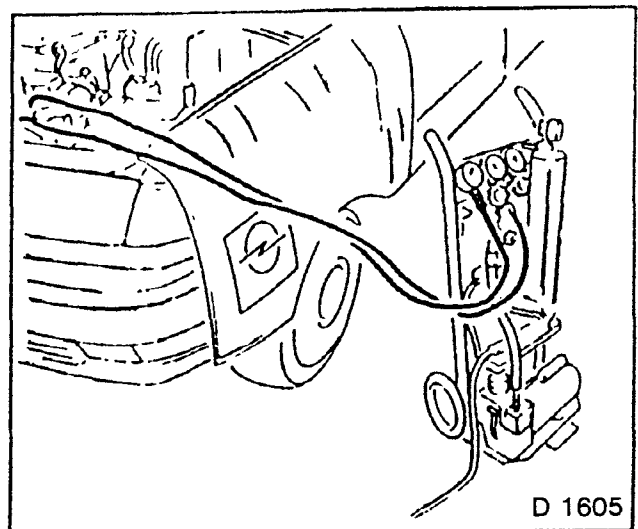


Fig. 81

## Accumulator — Remove and Install

1. Drain air conditioning.

### REMOVE, DISCONNECT

1. Pipe line (A).
2. Pipe line (B).
3. Close openings immediately with plugs.
4. Accumulator with insulation from bracket.
5. Insulation from accumulator.

### INSTALL, CONNECT

1. Accumulator with insulation.
2. Pipe line (A)
3. Pipe line (B).
4. Evacuate and charge air conditioning.
5. Lubricate new rubber O-rings with refrigerant oil and install.
6. Refrigerant oil filling quantity: 45 cm<sup>3</sup>

### TIGHTEN (TORQUE)

1. Pipe and hose lines — see Technical Data

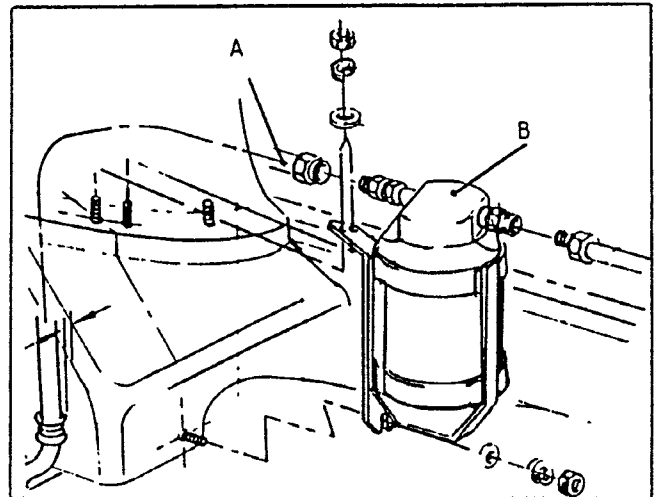


Fig. 82

## Condenser — Remove and Install Accumulator — Replace

### REMOVE, DISCONNECT

1. Drain air conditioning.
2. Radiator.
3. Radiator grille
4. Refrigerant line (1)
5. Screw

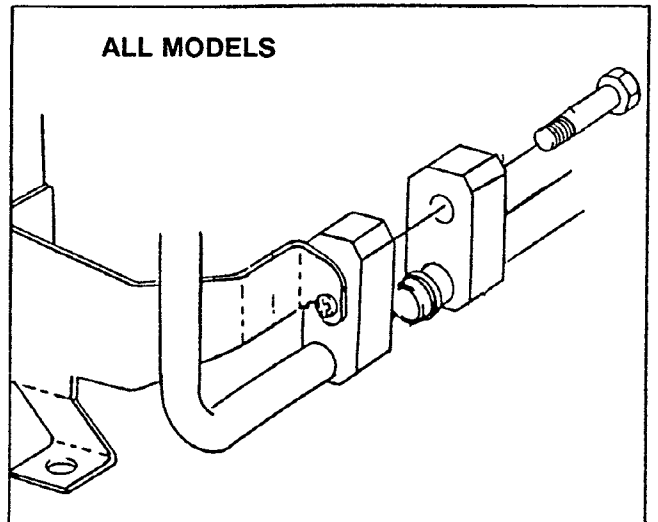


Fig. 83

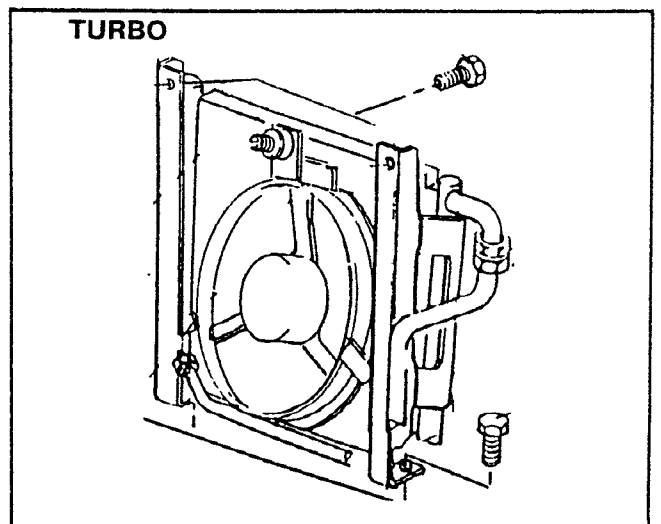


Fig. 84

**REMOVE, DISCONNECT**

1. Power steering lines from crossmember (1).
2. Condenser from air deflector (2).
3. Condenser from vehicle.

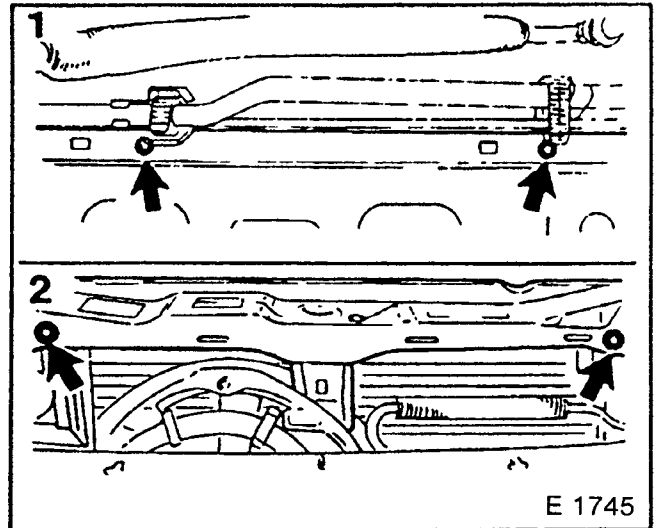


Fig. 85

**INSTALL, CONNECT**

- 1 Condenser to rubber guides in front member and to air deflector.
2. Power steering lines to crossmember.
- 3 Screw refrigerant lines with new O-rings.
- 4 Lubricate O-rings with special refrigerant oil.
5. Radiator grille.
- 6 Radiator.
- 7 Evacuate and charge air conditioning

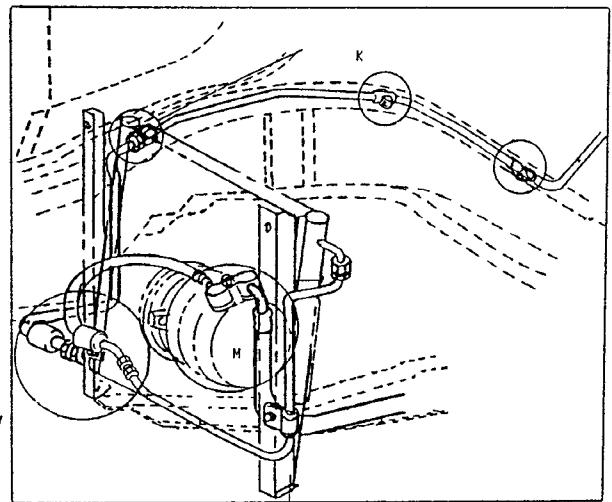


Fig. 86

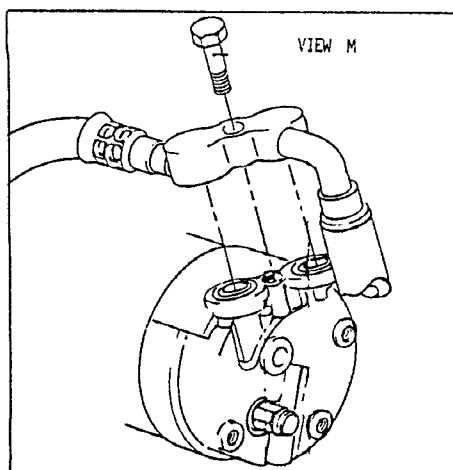


Fig. 88

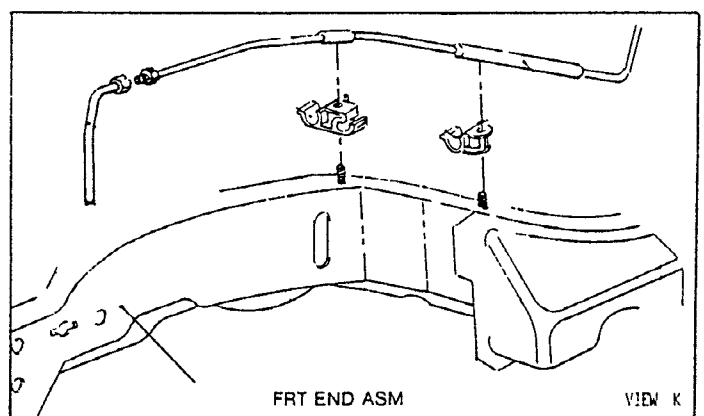


Fig. 87



**INSTALL, CONNECT**

1. Condenser to rubber guides in front member and to air deflector.
2. Power steering lines to crossmember.
3. Screw refrigerant lines with new O-rings.
4. Lubricate O-rings with special refrigerant oil.
5. Radiator grille.
6. Radiator.
7. Evacuate and charge air conditioning.

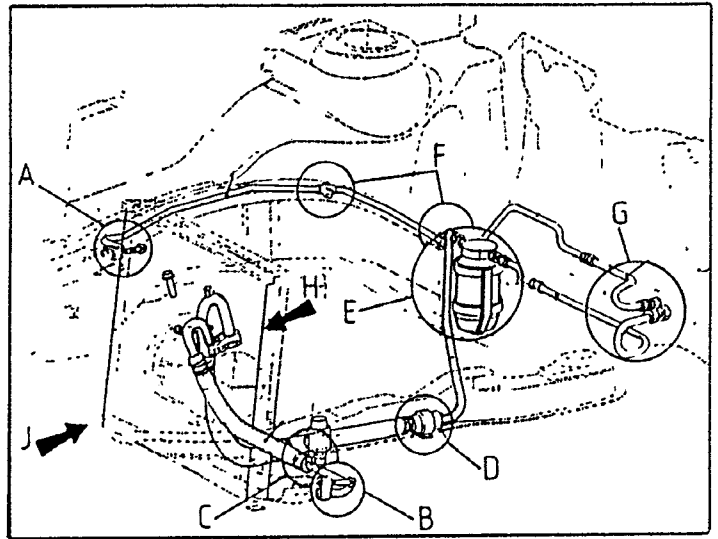
**ALL MODELS, EXCLUDING TURBO**

Fig. 89

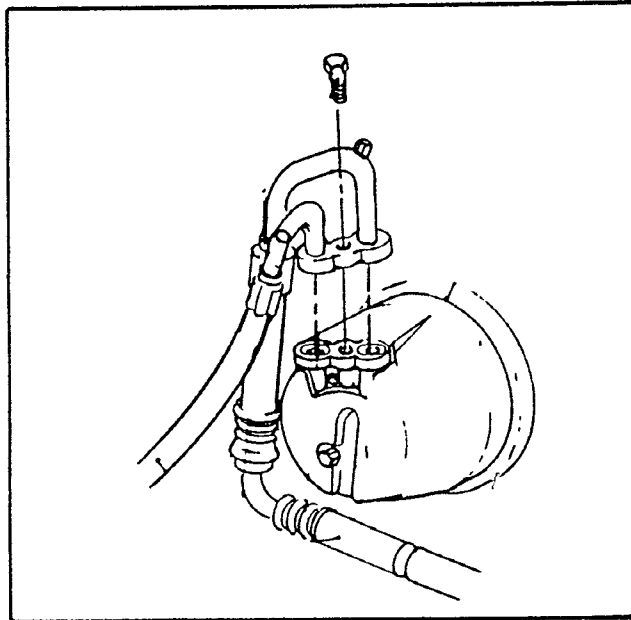


Fig. 90

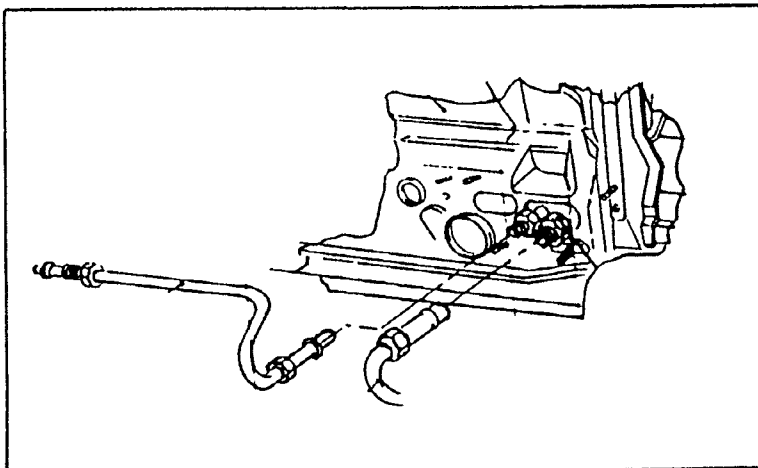


Fig. 91

## Booster Fan — Remove and Install

### REMOVE, DISCONNECT

1. Condenser.
2. Wiring harness plug.
3. Booster fan.

### INSTALL, CONNECT

1. Booster fan.
2. Wiring harness plug.
3. Condenser.

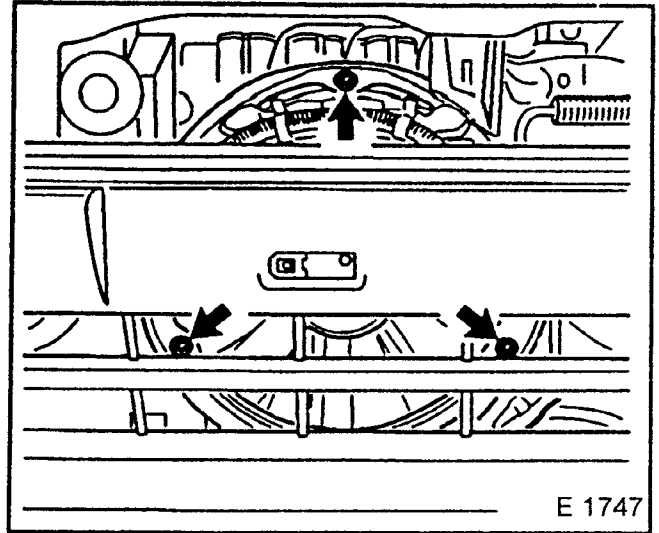


Fig. 92

## Evaporator — Remove and Install

### REMOVE, DISCONNECT

1. Drain air conditioning.
2. Footwell/storage compartment.
3. Upper footwell panelling.
4. Air duct.
5. Control unit.
6. Control unit bracket.

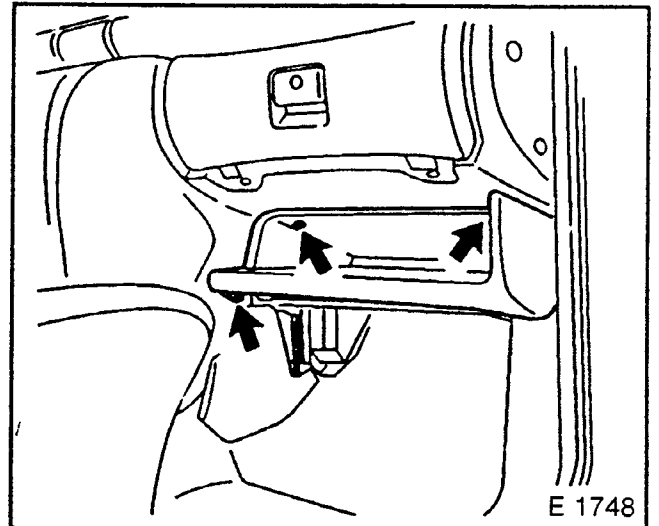


Fig. 93

7. Evaporator panelling.

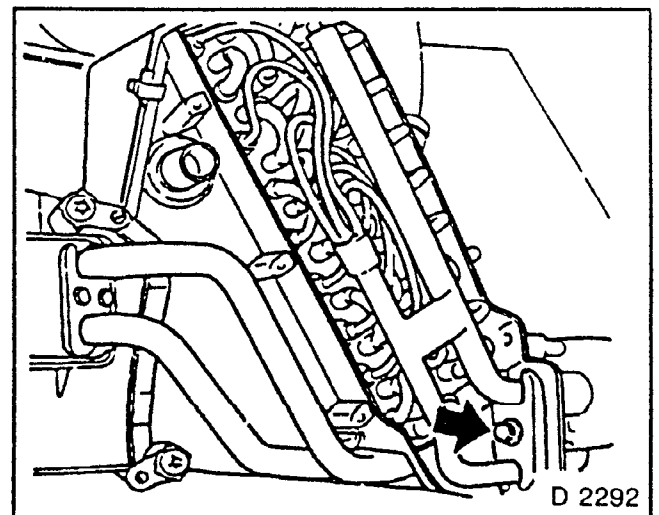


Fig. 94

**REMOVE, DISCONNECT**

1. Evaporator connections in passenger compartment.
2. Evaporator sideways from evaporator housing.

**INSTALL, CONNECT**

1. Evaporator sideways in evaporator housing.
2. Connections in passenger compartment and engine compartment.
3. Condensation hose.
4. Cover on evaporator housing.
5. Air distributor duct for right footwell.
6. Switch console.
7. Footwell panelling.
8. Glove compartment
9. Evacuate and charge air conditioning.

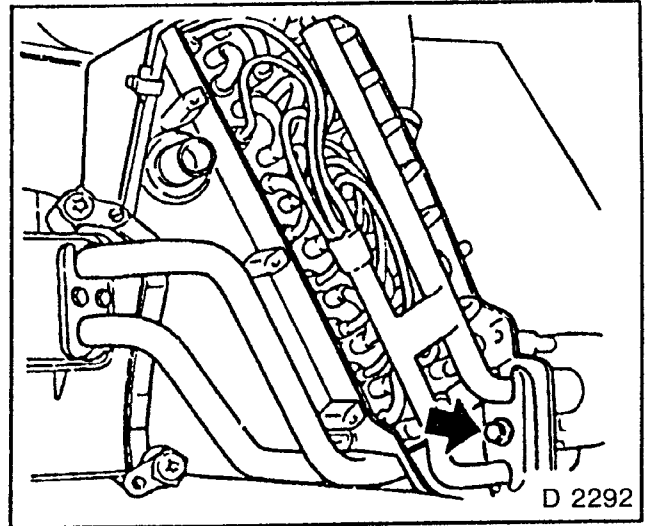


Fig. 95

## Pipes and Hoses

Pipes are of aluminium, in some cases with a heat protection coating.

Installation of Pipes and Flange Connections.

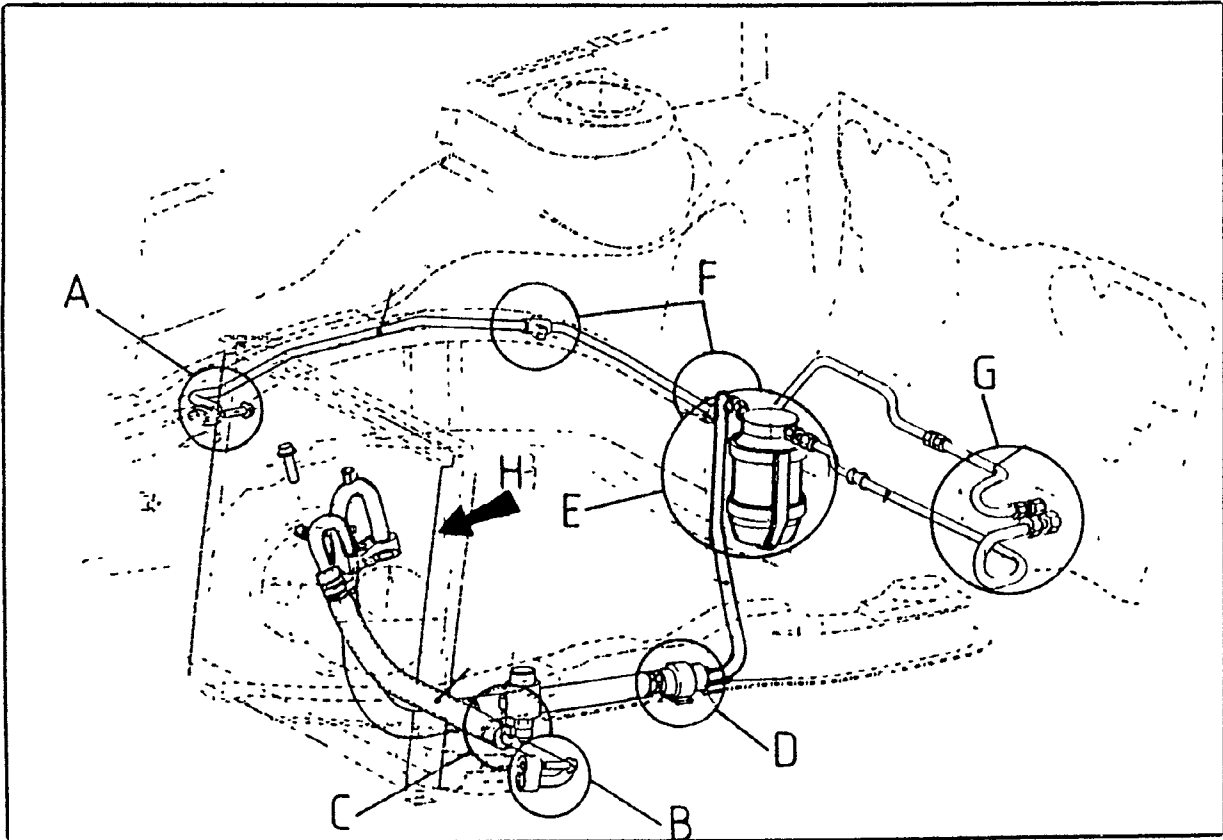


Fig. 96

## Pipe and Hose Lines — Remove and Install

Drain air conditioning.

### REMOVE, DISCONNECT

1. Pipe and hose lines.
2. Close counterpart with plug immediately.

### INSTALL, CONNECT

1. Use new rubber O-rings and insert using refrigerant oil.
2. Always counterhold when screwing parts together.
3. Evacuate and charge air conditioning.

### TIGHTEN (TORQUE)

Torques — see Technical Data.

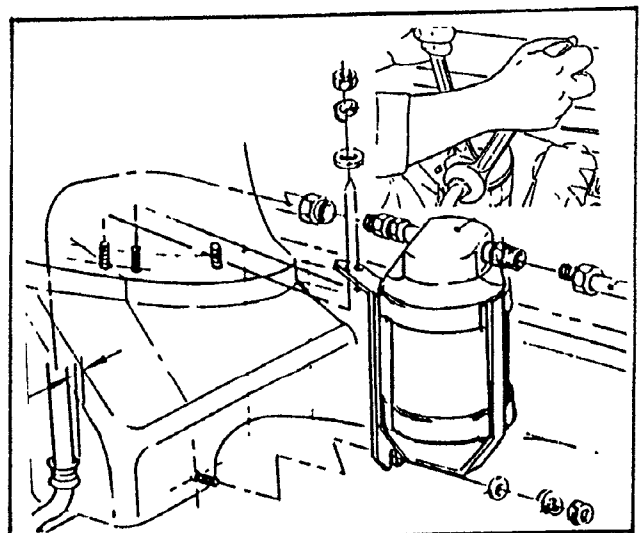


Fig. 97

# Location of Switches

- 1 — Triple switch
- 2 — Motronic switch
- 3 — Coolant temperature switch (S 29)
- 4 — Coolant temperature switch (S 128)

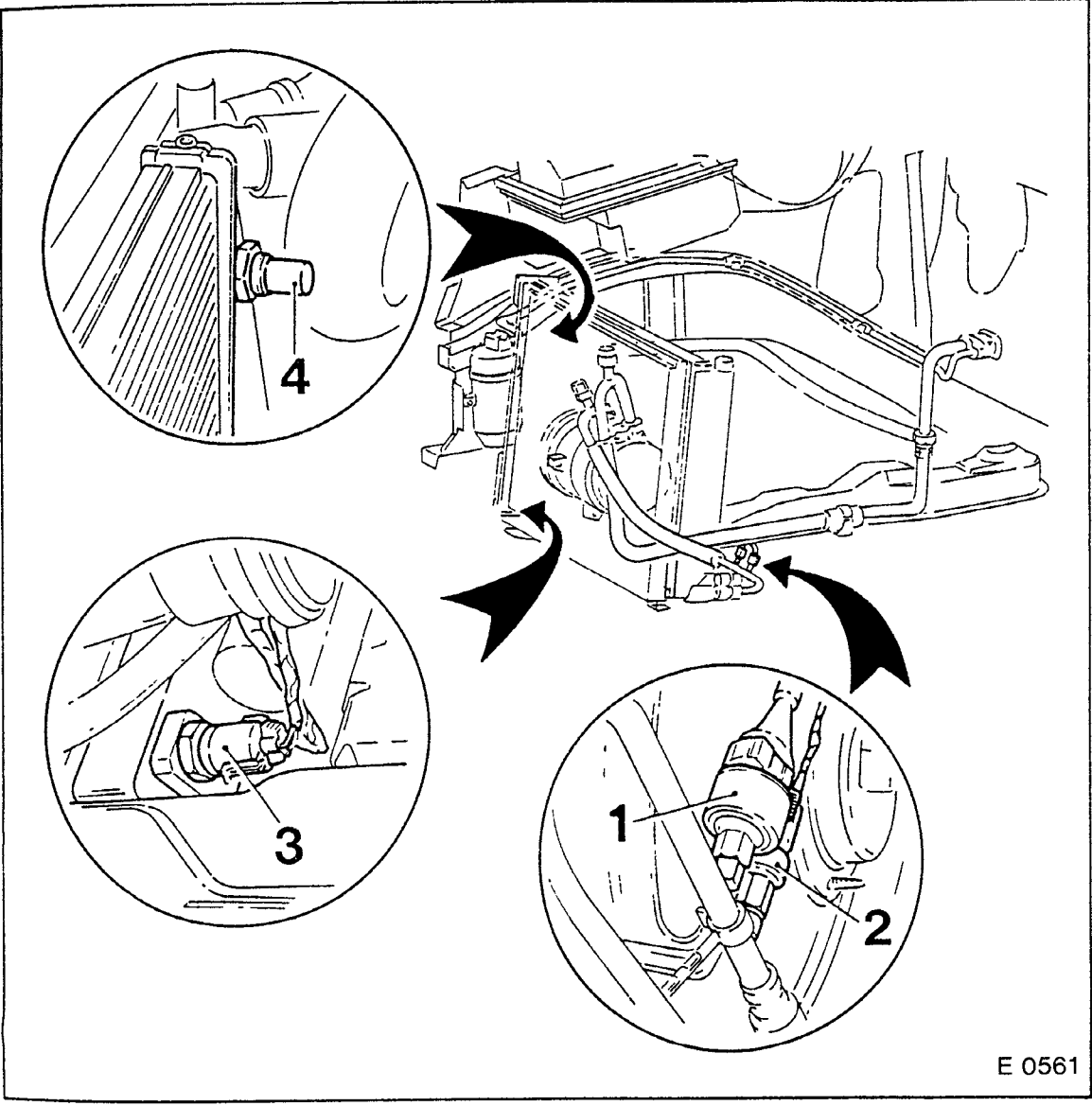


Fig 98

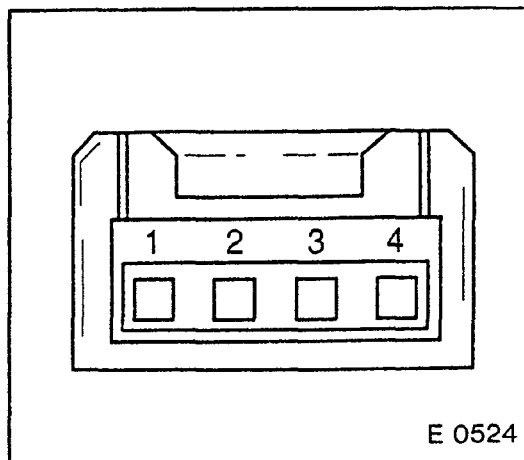
## TRIPLE SWITCH

The triple switch consists of:

- Low pressure safety switch
- High pressure safety switch
- Booster fan switch

It reacts to three different pressure stages in the high pressure line and activates the appropriate switching circuit.

The triple switch is located in the high pressure line between compressor and condenser.



E 0524

Fig. 99

## TERMINAL ASSIGNMENT:

- 1 and 2 = connections for high and low pressure safety switches
- 3 and 4 = booster fan connection

## LOW PRESSURE SAFETY SWITCH

The low pressure safety switch switches off the compressor magnetic coupling when pressure in the refrigerant circuit falls to approximately 180 kPa (1.8 bar). The reason for a drop in pressure is either an outside temperature that is too low, or more generally too little refrigerant, caused by a leak in the refrigerant circuit. As the refrigerant transports the compressor lubricant in the refrigerant circuit and a leak can lead to loss of both, the compressor switches off as a safety measure to protect it from damage caused by lack of lubricant. The low pressure safety switch switches the compressor on again when the pressure exceeds 250 kPa (2.5 bar).

## HIGH PRESSURE SAFETY SWITCH

The high pressure safety switch switches off the magnetic coupling of the compressor if the pressure in the refrigerant circuit exceeds approximately 3 000 kPa (30 bar). Reasons for this can be, for example, dirt on the outside of the condenser, failure of the booster fan, unusually high outside temperature or extreme engine load. The high pressure safety switch switches the compressor on again when pressure drops below normal, approximately 2 000 kPa (20 bar).

## BOOSTER FAN SWITCH

If pressure in the condenser increases, so too does the temperature. To prevent pressures being reached in the refrigerant circuit that are

higher than permitted, if pressure exceeds 1 900 kPa (19 bar) the switch automatically switches the booster fan and the radiator fan from stage 1 to stage 2. When the pressure drops below approximately 1 500 kPa (15 bar) again, the switch switches back to stage 1.

## MOTRONIC SWITCH (ENGINE SPEED INCREASE SWITCH)

When pressure in the refrigerant circuit reaches approximately 1 100 kPa (11 bar), the Motronic switch increases engine idle speed. Loss of engine speed caused by switching on the air conditioning system is compensated for. When pressure falls to 900 kPa (9 bar) the Motronic switch switches off again.

The switch is located in the high pressure line between compressor and condenser.

## COOLANT TEMPERATURE SWITCH

There are two coolant temperature switches installed in the engine cooling system.

The switch (S 29) on the lower side of the radiator is the cooling fan switch which is also used on vehicles without air conditioning. It switches on the radiator fan and booster fan in sequence when the coolant temperature reaches 100°C/212°F. When the temperature drops to 95°C/203°F the radiator and booster fans switch off again.

The switch (S 128) in the upper half of the engine cooling system is a switch with two contacts. At 105°C/222°F one contact switches the booster fan and radiator fan to stage 2 and at 100°C/212°F switches them back to stage 1. The other contact switches the compressor magnetic coupling off at 120°C/248°F and on again at 115°C/239°F.

**BLOCK DIAGRAM**

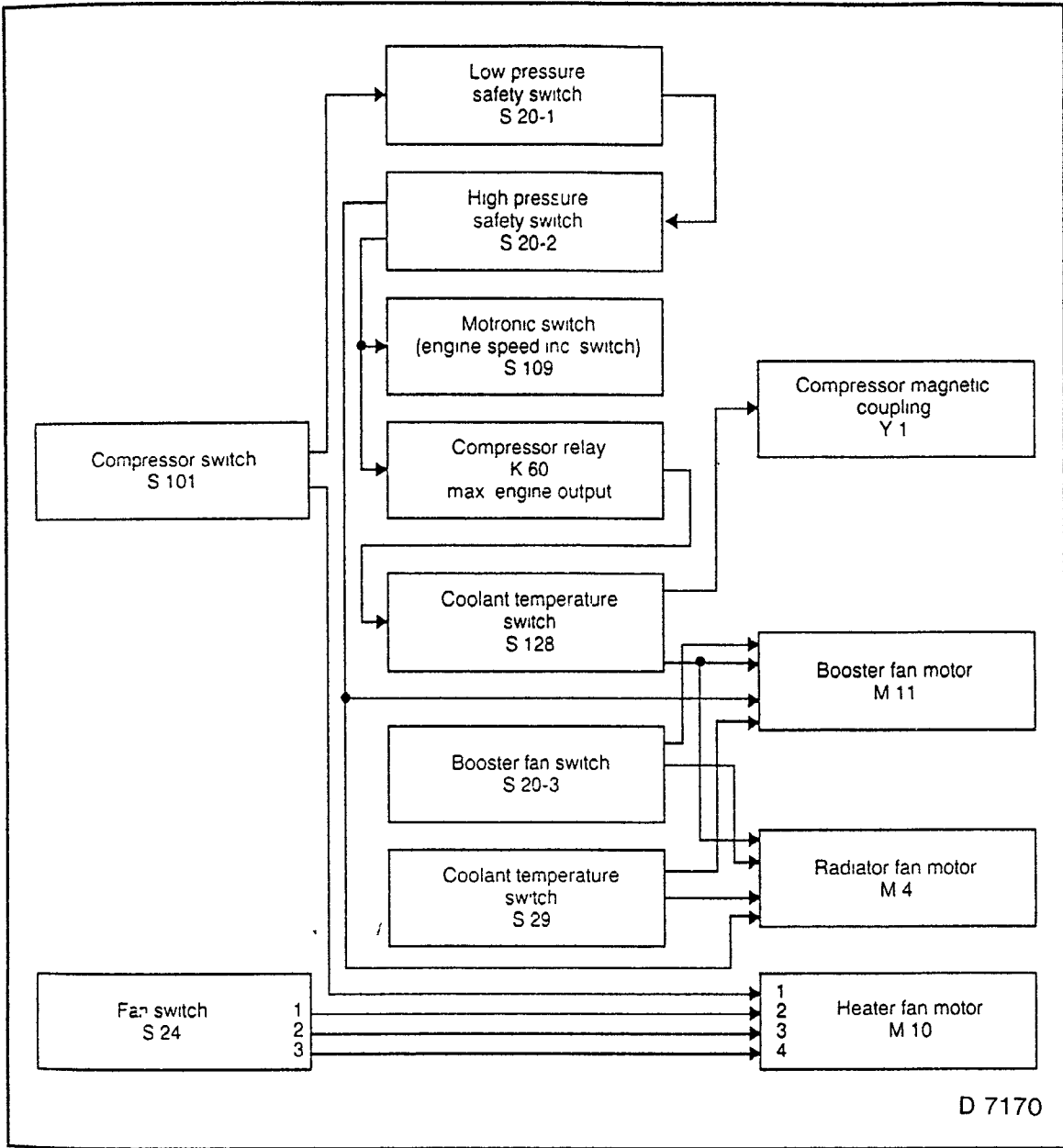


Fig. 100

## Coolant Temperature Switch — Replace

### REMOVE, DISCONNECT

1. Drain coolant partly.
2. Wiring harness plug.
3. Coolant temperature switch.

### INSTALL, CONNECT

1. Coolant temperature switch with new seal — 21 Nm.
2. Wiring harness plug.
3. Top up coolant.

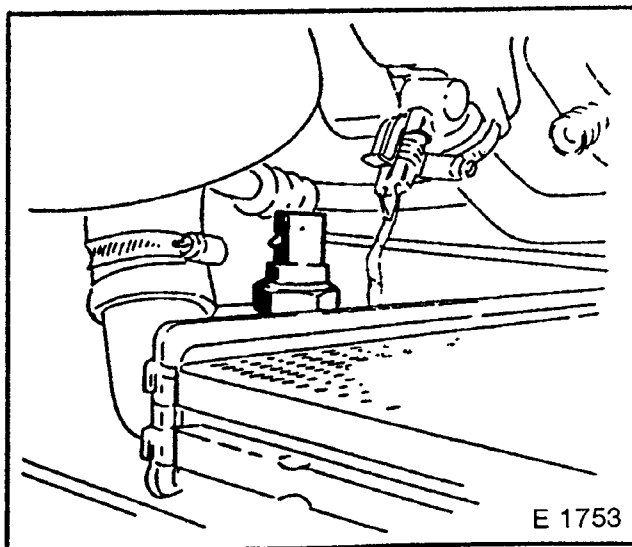


Fig. 101

## Triple Switch — Replace Motronic Switch — Replace

### REMOVE, DISCONNECT

- 1 Drain air conditioning
2. Wiring harness plug.
3. Switch.

- 1 = Triple switch  
2 = Motronic switch

### INSTALL, CONNECT

1. Switch with new seal — 7 Nm
- 2 Wiring harness plug
3. Evacuate and charge air conditioning.

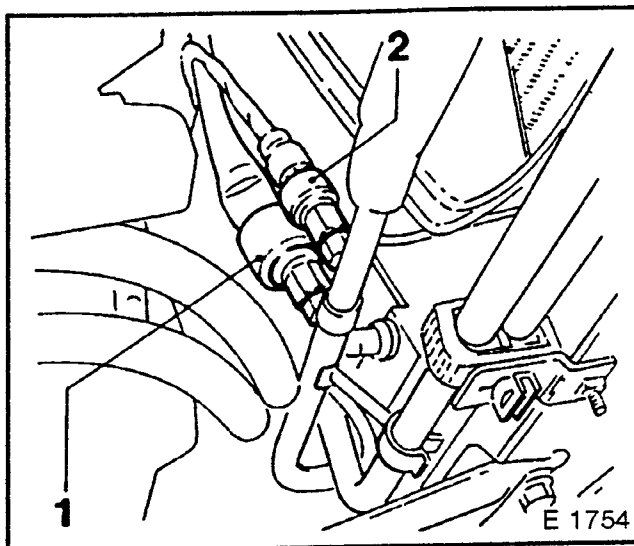


Fig. 102

## Compressor — Remove and Install

### REMOVE, DISCONNECT

1. Drain air conditioning.
2. Air intake hose.
3. Attach engine to Engine Holder  
KM — 263 — B

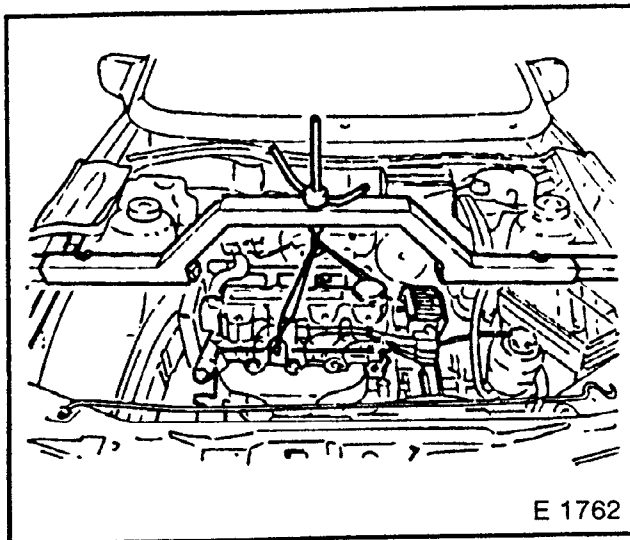


Fig. 103



4. Refrigerant line from compressor.

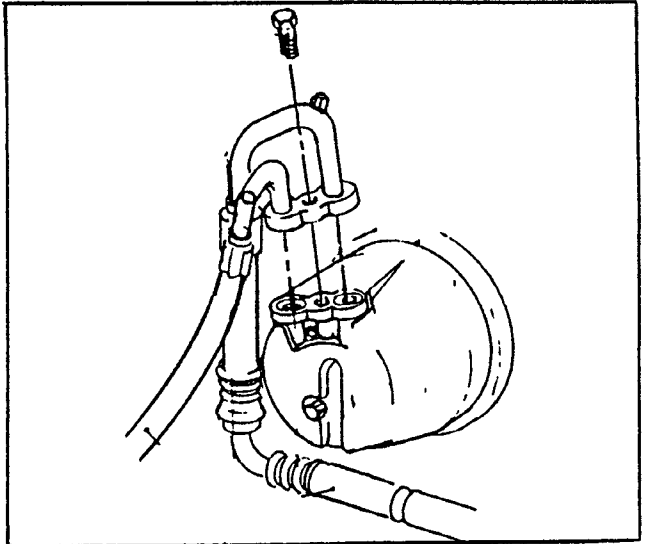


Fig. 104

## REMOVE, DISCONNECT

1. Right engine damping block from side member (1).
2. Lower engine slowly.
3. Loosen panelling from wheel well.
4. Engine suspension bracket from hydraulic pump/compressor support (2).

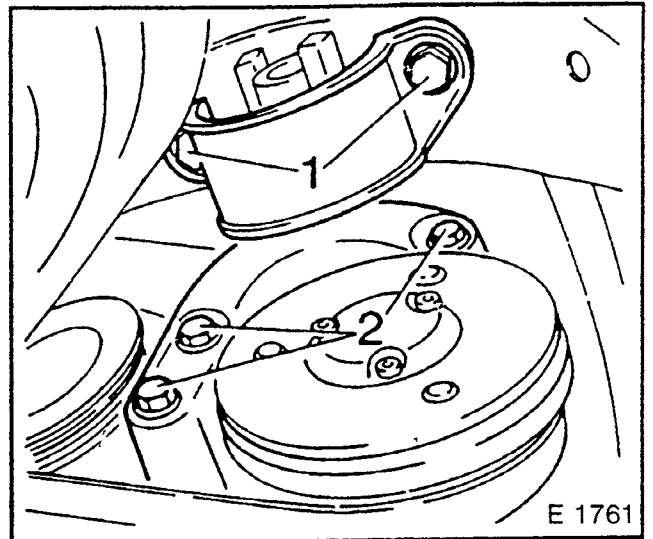


Fig 105

5. Pretension ribbed V-belt tension roller in direction of arrow.
6. Detach ribbed V-belt

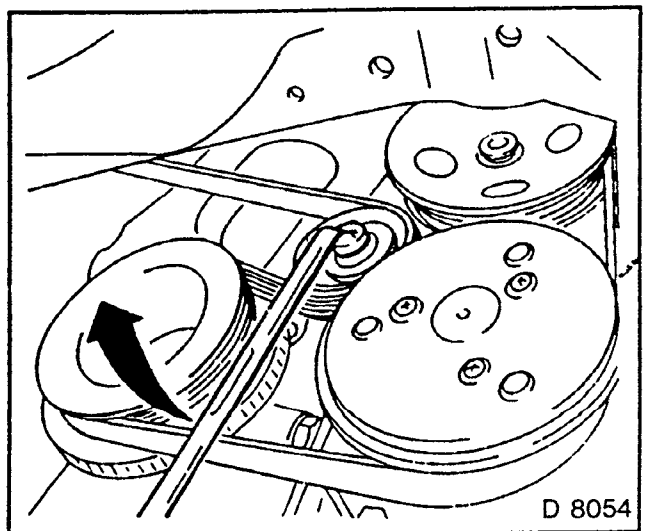


Fig. 106

**REMOVE, DISCONNECT**

1. Wiring harness plug (1).

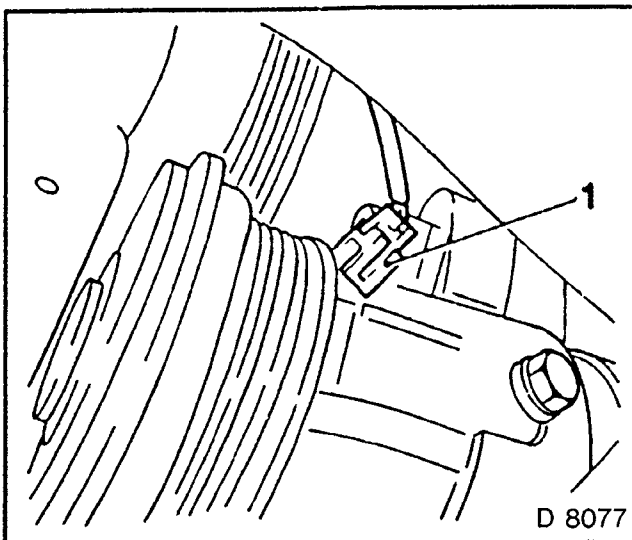


Fig. 107

2. Compressor from hydraulic pump/  
compressor support (1).

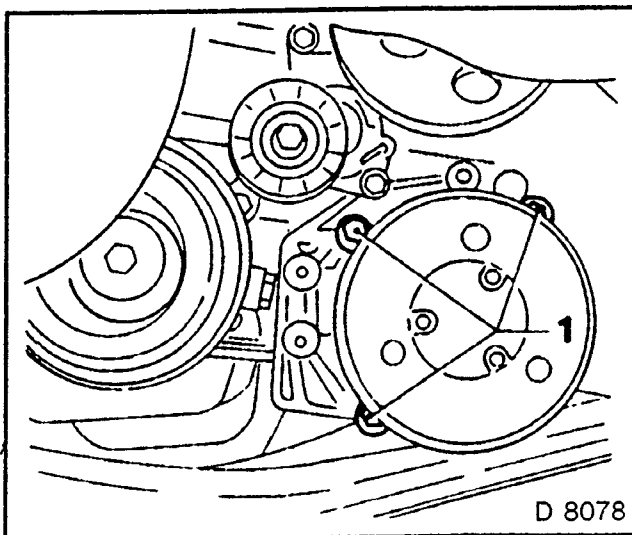


Fig 108

**REMOVE, DISCONNECT**

- 1 Compressor from bracket (1)  
Fig 109 shows exhaust manifold
2. Remove compressor.

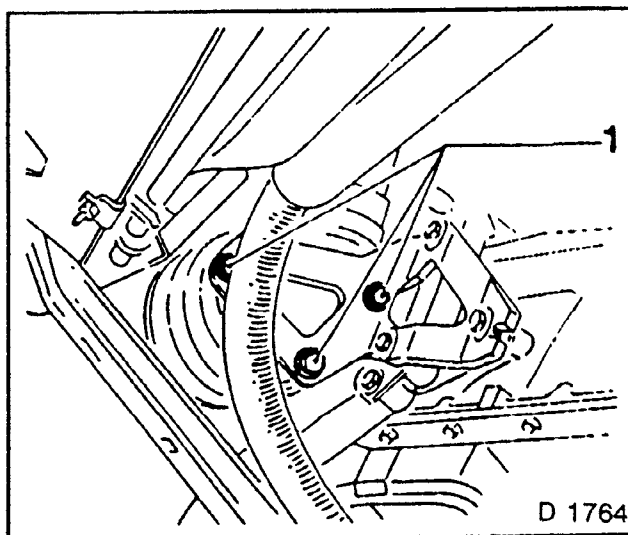


Fig. 109

**INSTALL, CONNECT**

1. Compressor to bracket and support.
2. Wiring plug
3. Refrigerant lines with new O-rings — lubricate O-rings with special refrigerant oil.
4. Wiring harness plug.
5. Pretension tension roller and attach ribbed V-belt — ribbed V-belt is tensioned automatically.

**INSTALL, CONNECT**

1. Engine suspension bracket to support — 60 Nm.
2. Panelling to wheel well.
3. Engine damping block to side member — recut thread, use locking compound — 65 Nm.

**REMOVE, DISCONNECT**

- 1 Engine bracket.

**INSTALL, CONNECT**

1. Air intake hose.
2. Evacuate and charge air conditioning

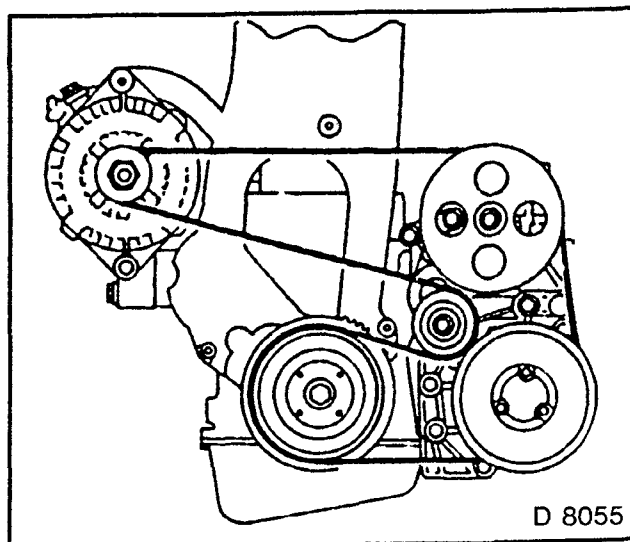


Fig. 110

## Compressor Clutch — Replace

Fig. 111 show operations on removed compressor.

### REMOVE, DISCONNECT

1. Compressor clutch cover.
2. Fastening nuts — counterhold with KM — J — 33027 — A.

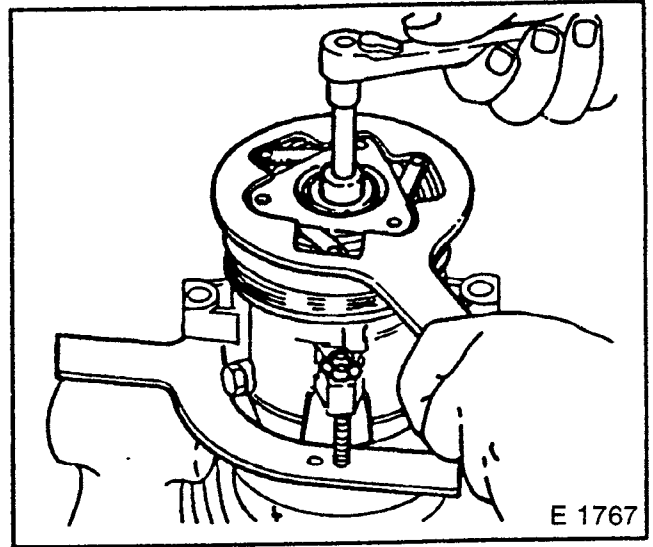


Fig 111

3. Compressor clutch — KM — J — 33013 — B.
4. Woodruff key.

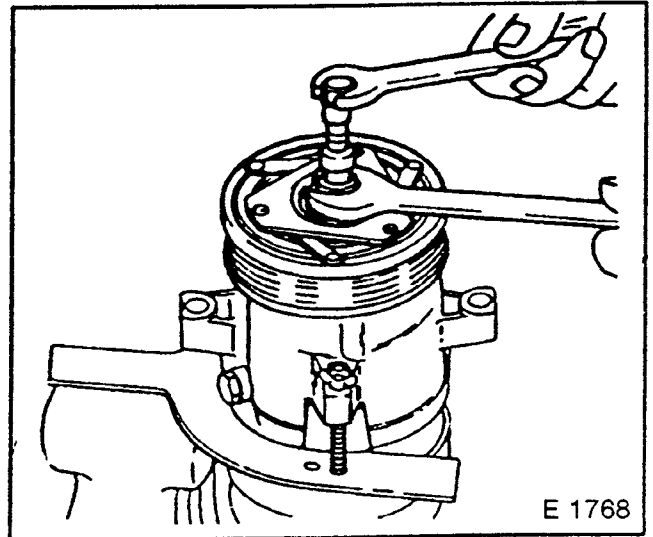


Fig. 112

### INSTALL, CONNECT

1. Woodruff key in shaft groove.
2. Put on compressor clutch — **DO NOT** drive in

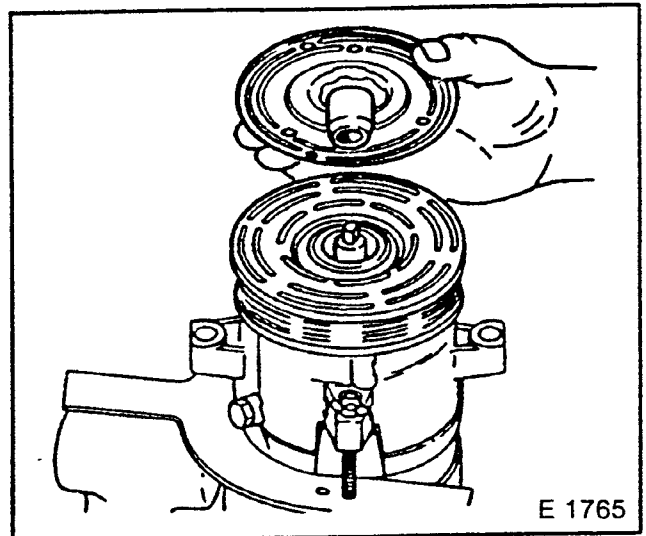


Fig. 113

3. Press on compressor clutch — KM — J — 33013 — B — until gap (1) between compressor clutch and pulley assembly is 0.4 to 1.0 mm.
4. Fastening nuts — 11 to 22 Nm.
5. Compressor clutch cover.

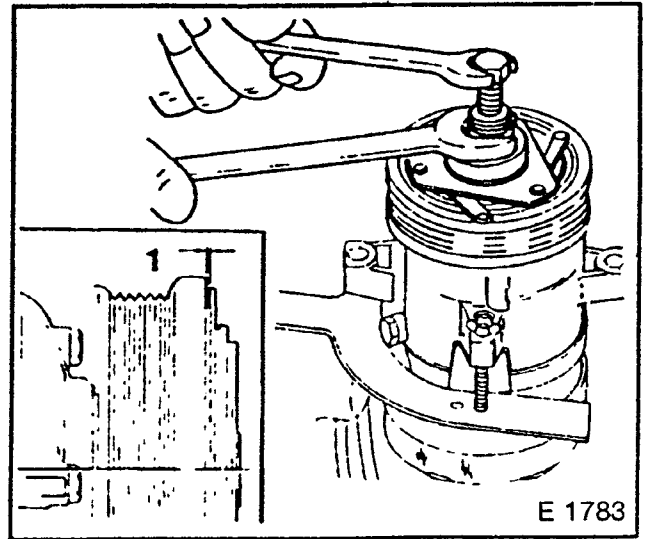


Fig. 114

## Compressor Pulley Assembly — Replace

### REMOVE, DISCONNECT

1. Compressor
2. Compressor clutch
3. Retaining ring.
4. Pulley assembly — KM — J — 33020.

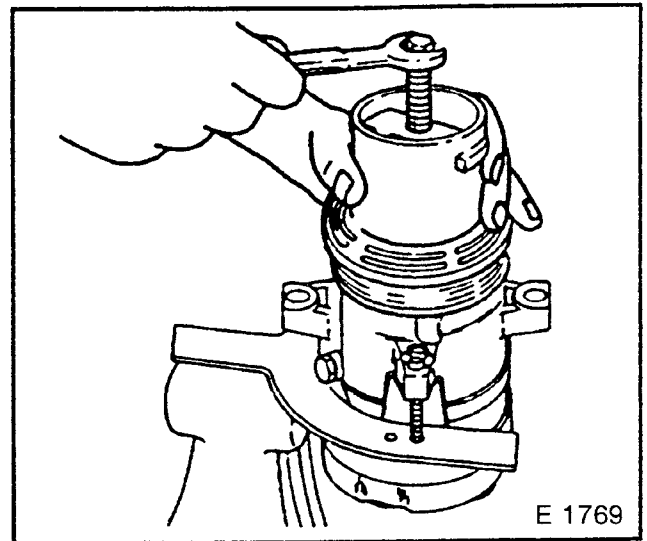


Fig. 115

### INSTALL, CONNECT

1. Pulley assembly — KM — J — 33017 (1), KM — J — 33023 (2), KM — J — 8433 (3).
2. Retaining ring.
3. Compressor clutch.
4. Compressor.

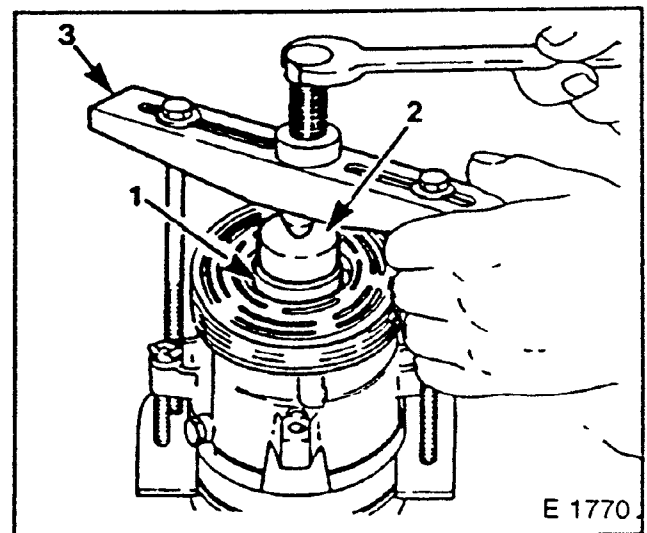


Fig. 116

## Compressor Safety Valve — Replace

**NOTE:**  
IF THE STICKER (1) IS MISSING, THE VALVE HAS BEEN TRIGGERED.

### REMOVE, DISCONNECT

1. If necessary, drain air conditioning.
2. Safety valve (2) from reverse of compressor.

### INSTALL, CONNECT

1. Safety valve with new ring — lubricate O-ring with special mineral oil (Technical Data) — 13.5 to 19 N m
2. Evacuate and charge air conditioning.

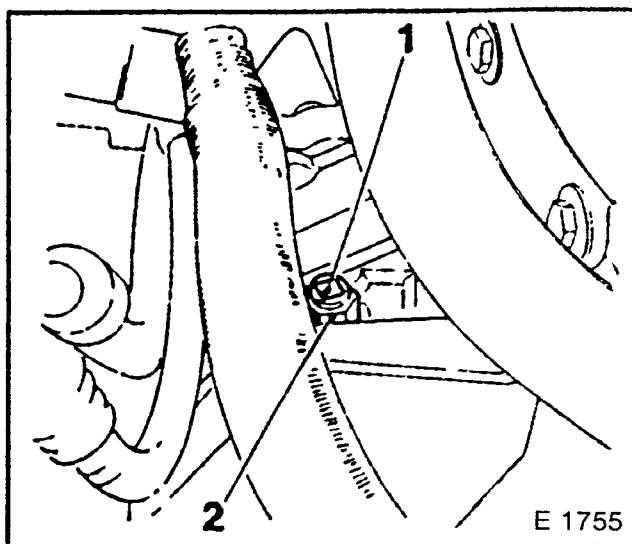


Fig. 117

## Compressor Control Valve — Replace

### REMOVE, DISCONNECT

1. Drain air conditioning.
2. Retaining ring (1)
3. Control valve (2).

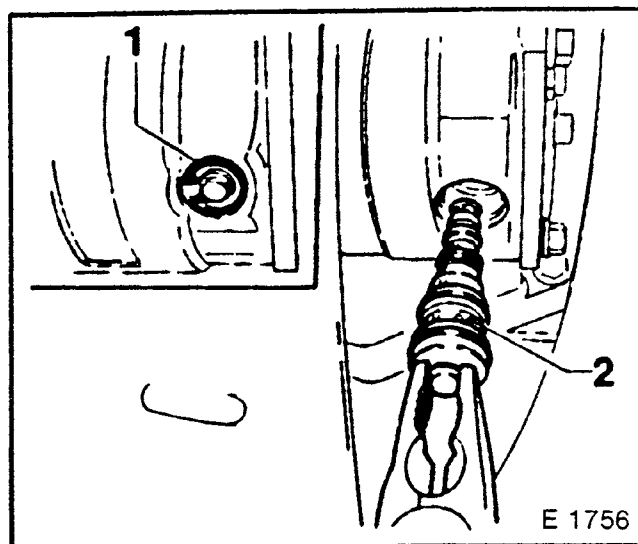


Fig. 118

### INSTALL, CONNECT

1. Control valve with new O-rings — lubricate O-rings with refrigerant oil.
2. New retaining ring.
3. Evacuate and charge air conditioning.

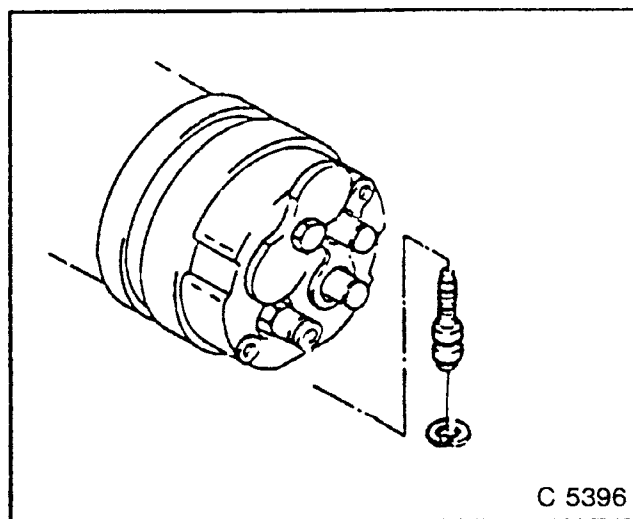


Fig. 119

## Valve — Glove Compartment Cooling — Replace

### REMOVE, DISCONNECT

1. Footwell panelling/passenger side storage tray.
2. Remove hose from valve.
3. Valve — press in lugs.

### INSTALL, CONNECT

1. Valve.
2. Hose.
3. Footwell panelling/passenger side storage tray.

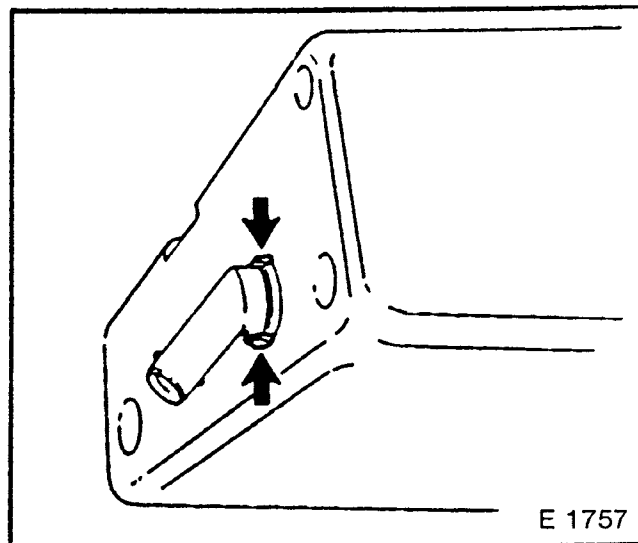


Fig. 120

## SPECIAL SERVICE TOOLS

### MKM — 596 TEMPERATURE GAUGE.

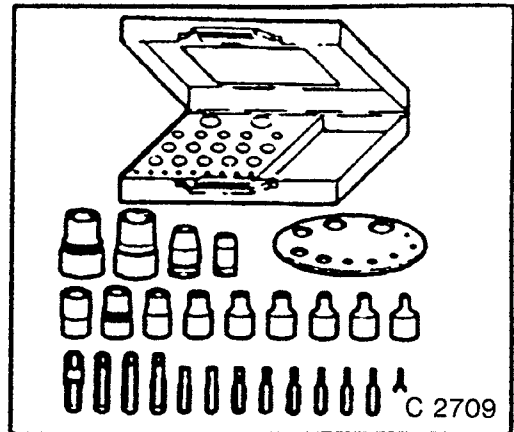
To measure the vent nozzle output temperature.

### MKM — 587 —A MULTIMETER.

To measure voltage and resistance.

### MKM — 604 —B TORX WRENCH SET.

To loosen/tighten inner/outer TORX bolts.

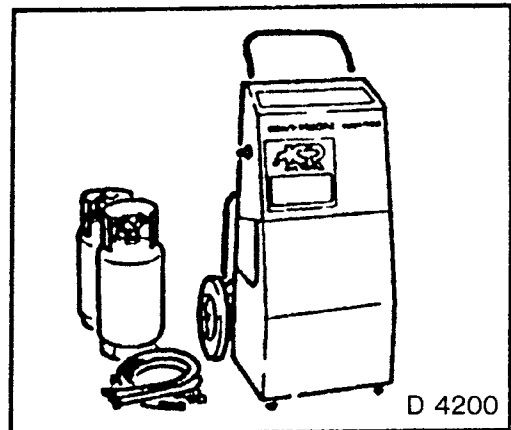


### KM — 609 ELECTRONIC KIT I.

In conjunction with KM — 587 — A

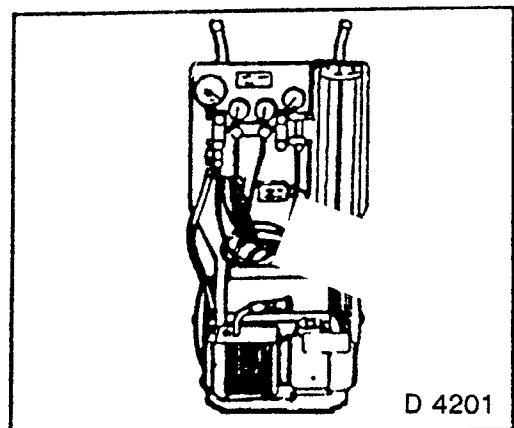
### MKM — 720 RECYCLING STATION.

To drain the air conditioning system



### MKM — 721 EVACUATING AND CHARGING STATION

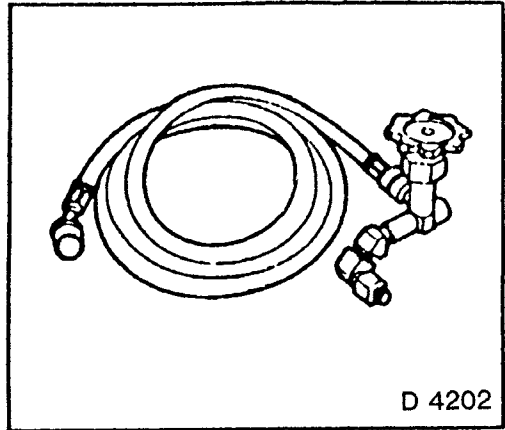
To evacuate and charge the air conditioning system.





**MKM — 722 AUXILIARY VALVE.**

For older Kent — Moore Evacuating and Charging Stations.  
In conjunction with MKM — 720.



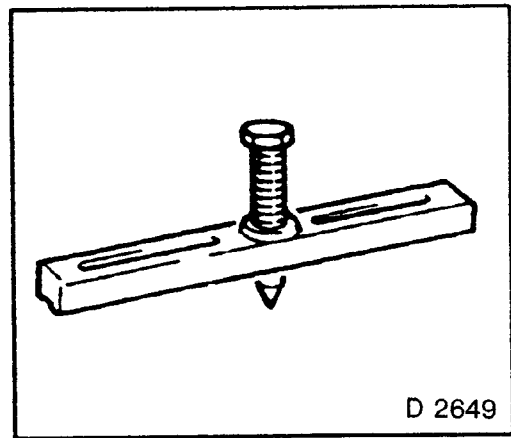
D 4202

**SERVICE STATION/17734**

To drain, evacuate and charge air conditioning.

**KM — J — 8433 REMOVER**

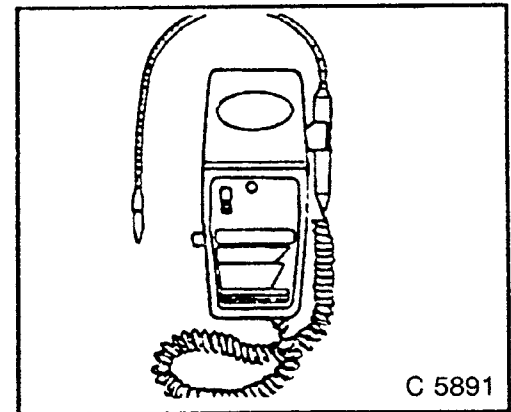
To press off compressor pulley assembly.



D 2649

**14950 — A LEAK DETECTOR UNIT**

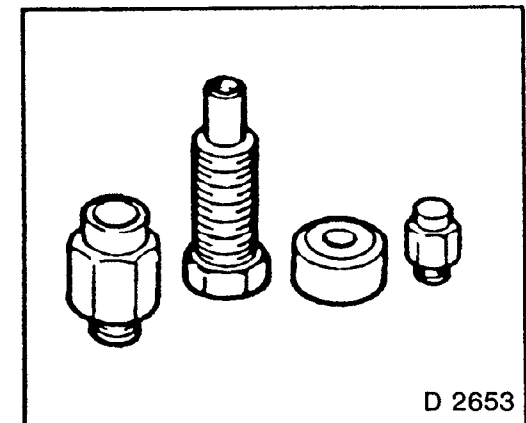
To check the air conditioning system for leaks



C 5891

**KM — J — 33013 — B REMOVER/  
INSTALLER**

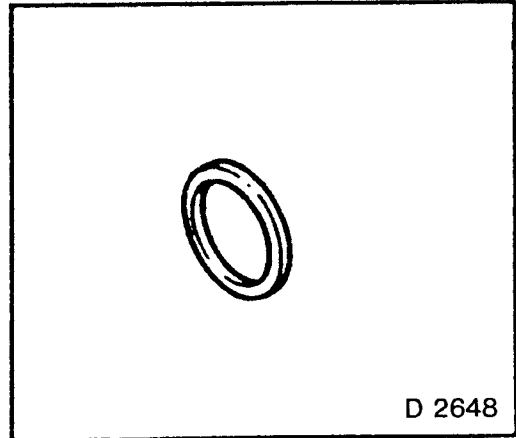
To remove and install compressor clutch.



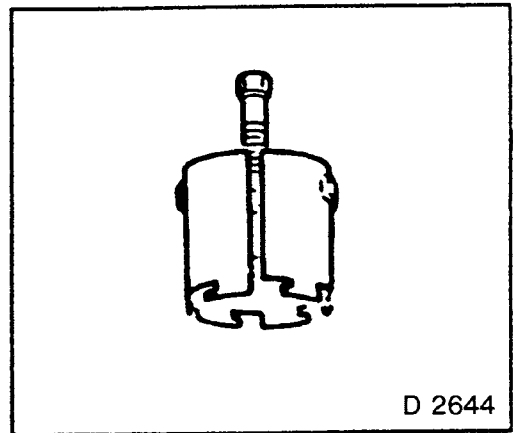
D 2653

**KM — J — 33017 INSTALLER**

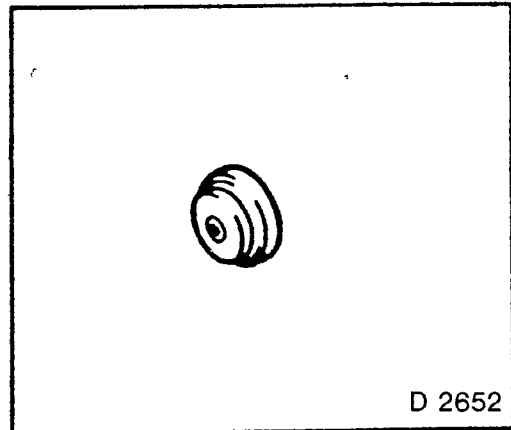
To install compressor pulley assembly.

**KM — J — 33020 REMOVER**

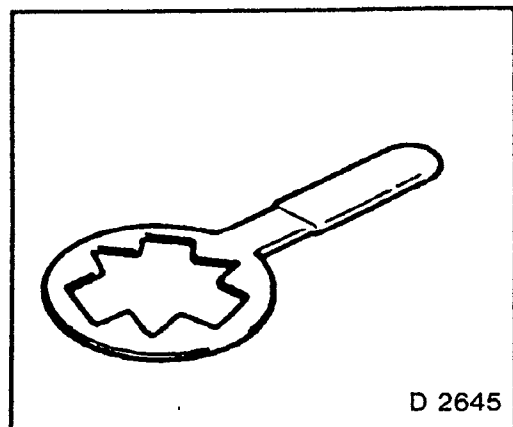
To remove compressor pulley assembly.

**KM — J 33023 INSTALLER**

To install compressor pulley assembly.

**KM — J — 33027 — A HOLDING  
WRENCH**

To counterhold compressor clutch.



## TECHNICAL DATA

Refrigerant	R-12	Part No. 19-49-870
Compressor lubricant	BVM oil	(90-001-810)
O-ring lubricant	BVM oil	(90-001-810)

### FILLING QUANTITIES:

Refrigerant	900 g	
Compressor lubricant	approx. 300 ml	
Pressure in low pressure range	190 to 219 kPa*	1.9 to 2.1 bar
Pressure in high pressure range	1 000 to 1 800 kPa*	10 to 18 bar

\*At approximately 20°C/68°F, engine speed approximately 1 500 rpm, AC system on

### SWITCH PRESSURES:

	On	Off
Low pressure safety switch	250 kPa	180 kPa
High pressure safety switch	2 000 kPa	3 000 kPa
Booster fan switch	1 900 kPa	1 500 kPa
Motronic switch	1 100 kPa	900 kPa

### SWITCH TEMPERATURES

	On	Off
Coolant temperature switch (S 29)	100°C/212°F	95°C/203°F
Coolant temperature switch (S 128)		
Contact 1	105°C/221°F	100°C/212°F
Contact 2	115°C/239°F	120°C/248°F
Gap between magnetic coupling and pulley	0.4 to 1.0 mm	


### SCREW TIGHTENING TORQUES FOR REFRIGERANT LINES:

To compressor	40 Nm
To condenser	27 Nm
To accumulator	20 Nm
To evaporator	20 Nm
Pipe connection	44 Nm

### TORQUES:

Pipe outer diameter at connection	Torque	
	for steel*)	for copper or aluminium
Inches	Nm	Nm
1/4	14 — 20	7 — 9.5
3/8	41 — 47	15 — 18
1/2	41 — 47	21 — 27.5
5/8	41 — 47	29 — 37
3/4	41 — 47	38 — 45

\*) The torque values for steel apply only if both connected ends are made of steel.  
If the metals are different, the values for copper/aluminium apply.

**Opel Astra**  **Opel Kadett**

## **Workshop Manual**

### **Section E**

# **Frame, Front wheel Susp., Wheels & Tyres**

Issued by: Service Division  
Delta Motor Corporation  
July 1993

# Index

Page

## Frame

GENERAL INFORMATION .....	E-1
GENERAL NOTES FOR UNDERBODY REPAIR .....	E-1
INSTRUCTIONS FOR USE OF CHECKING AND STRAIGHTENING BENCH SYSTEMS .....	E-4
QUICK MEASURE METHOD .....	E-2
UNDERBODY DIMENSION CHART .....	E-5

## Front Wheel Suspension

GENERAL INFORMATION .....	E-13
---------------------------	------

## Checking and Adjusting Operations

TOE-OUT, ADJUST .....	E-14
CAMBER, CASTER AND TOE-OUT, CHECK .....	E-13

## Axle Driving Shaft, Wheel Bearing, Front Wheel Hub

AXLE DRIVING SHAFT, REMOVE AND INSTALL COMPLETELY .....	E-18
FOLDING COVERS OF ONE AXLE DRIVING SHAFT, REMOVE AND INSTALL .....	E-23
FRONT WHEEL HUB, REMOVE AND INSTALL .....	E-15
JOINT OF AXLE DRIVING SHAFT, REMOVE AND INSTALL INDIVIDUALLY .....	E-22
WHEEL BEARING, REMOVE AND INSTALL .....	E-15

## Spring Strut, Control Arm, Stabilizer, Front Axle Body

BALL JOINT ON CONTROL ARM, REMOVE AND INSTALL .....	E-32
CONTROL ARM, REMOVE AND INSTALL .....	E-29
DAMPING BUSHINGS IN CONTROL ARM, REMOVE AND INSTALL .....	E-31
FRONT AXLE BODY, REMOVE AND INSTALL .....	E-33
FRONT AXLE BODY, TRANSFER .....	E-33
FRONT SPRING AND/OR DAMPER RINGS, REMOVE AND INSTALL .....	E-26
PENDULUM, REMOVE AND INSTALL .....	E-37
SPRING STRUT CARTRIDGE, REMOVE AND INSTALL .....	E-27
SPRING STRUT, DISASSEMBLE ..	E-24
SPRING STRUT, REMOVE AND INSTALL .....	E-23
STABILIZER, REMOVE AND INSTALL ..	E-36
SUPPORT BEARING, REMOVE AND INSTALL .....	E-26

## Wheels, Tyres

FRONT AND REAR WHEELS — ELECTRONICALLY BALANCE .....	E-39
TYRE PRESSURES .....	E-41
WHEEL BALANCING .....	E-38
WHEELS AND TYRES ..	E-37

## Special Service Tools .....

E-42

## Technical Data

FRONT WHEEL ADJUSTMENT ..	E-46
RADIAL LATERAL RUN .....	E-46
RECOMMENDED TORQUE VALUES .....	E-47

# FRAME

## General Information

Labour operations concerning replacement of load — carrying body components are described in Section A. Before commencing any major operations, all parts which could obstruct work on the body or could be damaged or set on fire by flying sparks during cutting or welding operations are to be removed. They are to be relocated and/or protected with covers so that they cannot obstruct the work or be damaged.

For professional repair of vehicles damaged in accidents, use checking and straightening bench systems.

### WARNING:

All operations must be carried out at the technician's own responsibility according to the regulations of the local authorities regarding health protection, accident prevention and environmental protection.

The fuel tank and fuel pipes must always be removed if welding operations are performed near these parts. These measures help to prevent the risk of explosion or fire.

The vehicle must be secured on the lifting platform when a change in weight distribution is caused by the removal of parts. The vehicle is to be supported, so that the underbody cannot bend or warp under its own weight.

As all welded parts (primary and secondary frames) — especially in the area of the floor frame — are of great importance to the driving, operating and, above all, accident safety (deformation behaviour) of the vehicle, the given separation points, weld seam formations and welding processes must be observed according to the information in the Service Instructions.

The self-supporting body must be able to withstand the changing loads which occur during extreme driving conditions and must also have additional safety reserves.

Driving safety is guaranteed only when the entire body is in technically perfect condition, so that the forces arising during operation can be absorbed over long periods of time and without ill-effect.

The given operation procedures and methods should enable repair work to be correctly, professionally and economically carried out.

## General Notes for Underbody Repair

Deformations that occur must be returned to the original state by using cold forming and straightening systems.

If there are deformations in the area of the primary and secondary frames, always carry out repair work using checking and straightening bench equipment.

Only when these preconditions are fulfilled can a correct diagnosis be made and the procedure for repair determined on the basis of this

The given separation points, weld seam formations and welding processes must be observed with the utmost care, in order to achieve the original tensile behaviour.

For shielded arc welding (MAG), use active inert gasses, such as CO<sub>2</sub> (carbon dioxide) and mixed gasses with high argon content and percentages of oxygen and carbon dioxide.

The necessary contact pressure of the electrodes for resistance welding with a manual spot — welding tongs is not adequate with welding tongs with a length of over 50 cm.

“Genuine Delta Parts” with the corresponding anti-corrosion agents, damping and sealing compounds are to be used exclusively.

Labour operations dealing with the replacement of frame parts are described in Section “A”.

## Quick Measure Method

Instead of using welding gauges for frame repair, the advancement of technology now prescribes the usage of straightening benches (i.e. Celette Co., Car Bench Co.).

For quick evaluation of damage on the vehicle underbody, instructions are given in this section for the usage of an economical test method with the Telescope Measuring instrument MKM-642-A. Its usage is quite simple. Exchangeable measuring points are used to quickly locate actual values at different measuring locations. Removal of components or trailer hitch (if present) is not necessary.

Checking the axle alignment provides an additional evaluation of the extent of the damage.

At the front, wheel camber, toe-in and toe-out are measured (see operation "Wheel Camber, Toe-in and Toe-out, Check" in this section). When measuring the rear axle alignment, see corresponding operation "Rear Axle Alignment, Check" in section F.

Raising of the outer spring winding in its mounting is a clear way of checking for deformation at outrigger or frame side member.

Fig. 1 shows checking dimension between the rear axle supports — measured with bracket before hole exposed. The measured value is 1025 mm.

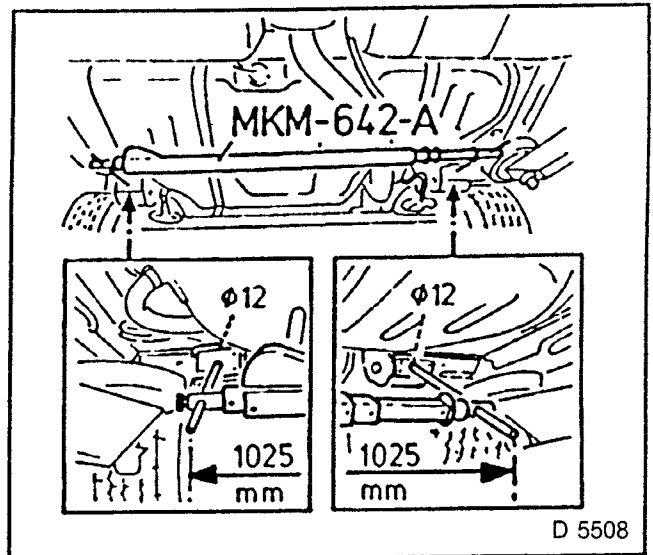


Fig 1

Fig. 2 shows checking dimension of the diagonal front frame to the rear frame.

The measurement is 1948 mm for the illustrated diagonal.

The measurement is 1965 mm for the other diagonal; the measuring cone from MKM-642-A can not be used for the rear right bore hole.

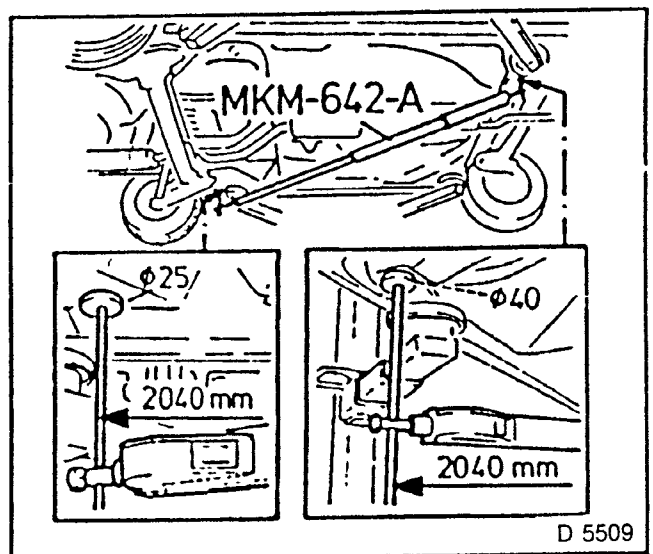


Fig. 2

Fig.3 shows checking dimension at lateral vehicle floor.  
The measurement is 1542 mm at the left side.  
The measurement at the right side is 1557 mm.

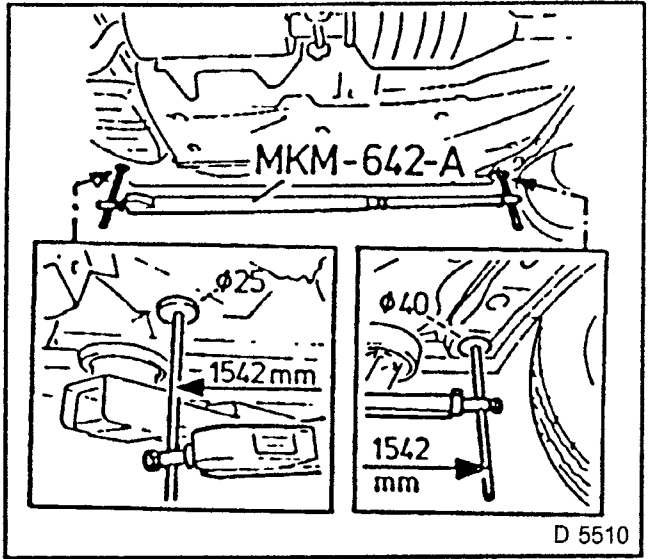


Fig. 3

Fig. 4 shows checking dimension between both front frames. The measurement is 920 mm

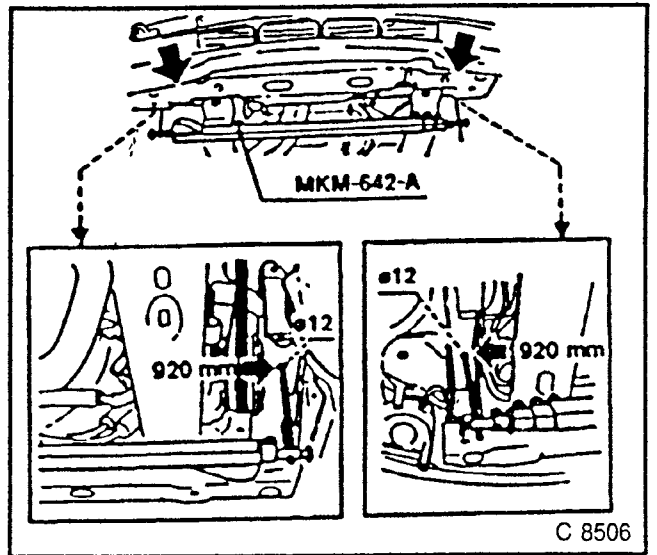


Fig 4

Fig. 5 shows checking dimension between both rear frames.  
The measurement is 1014 mm.  
With trailer hitch installed (bore holes are hidden): Use round heads of press pins as reference marks

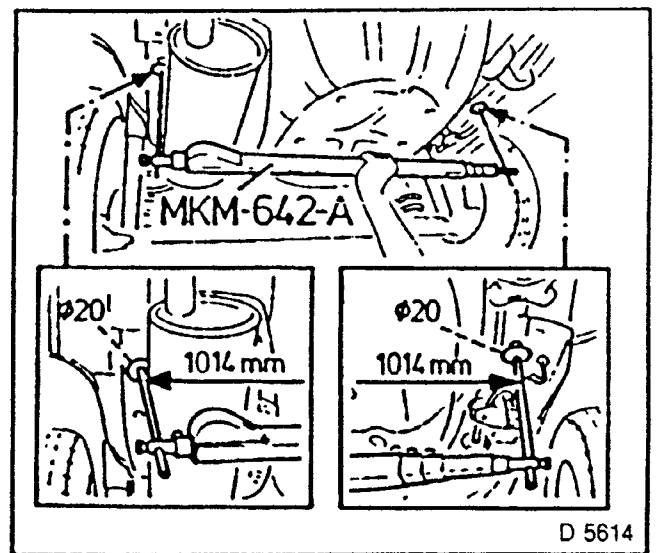


Fig 5



## Instructions for Use of Checking and Straightening Bench Systems

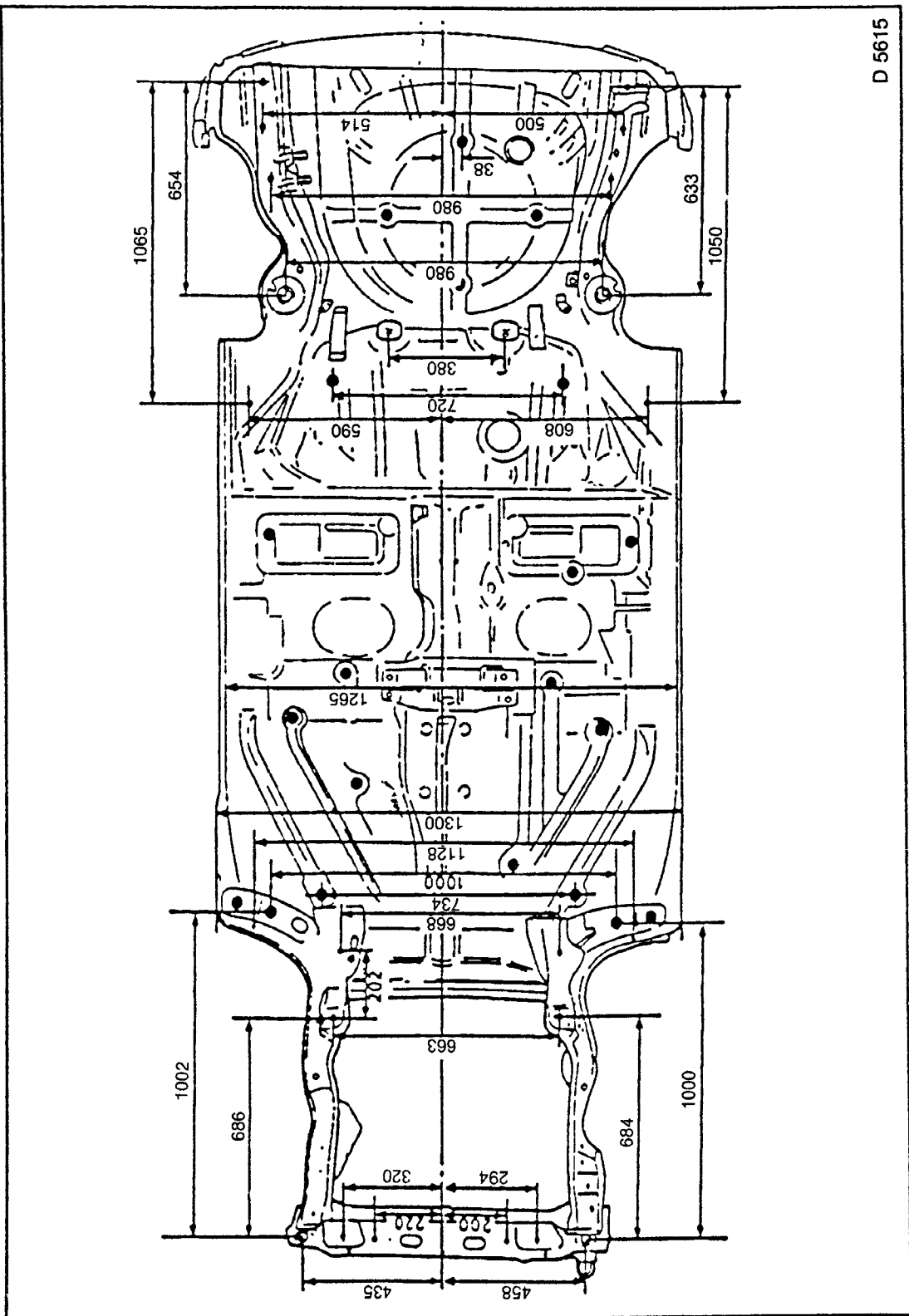
In order to guarantee exact repair of the deformed vehicle body, use checking and straightening bench systems. Using these systems, it is not only possible to check floor frame groups for warp, but also to directly align body components and, if necessary, to position new body components and weld them in exactly. Measurement and checking points on the floor frame groups and vehicle body are represented on the underbody dimension chart and in body dimension plan (see section A).

Observe the user instructions and regulations of the manufacturer of the straightening system.

The following body points are provided in the floor frame for positioning or probing:

- Check bore hole in front side member and front fastening in front axle body.
- Fastening of engine support.
- Upper spring strut mounting (spring strut dome)
- Front fastening for front axle body — not on vehicles with short outrigger.
- Rear fastening for front axle body.
- Central fastening for front axle body.
- Fastening for steering gear — left and right hand drive.
- Check bore hole and fastening for rear wheel suspension longitudinal brace.
- Rear shock absorber mounting.
- Check bore hole for rear side member.

**Underbody Dimension Chart — View from below**



D 5615

Fig 6

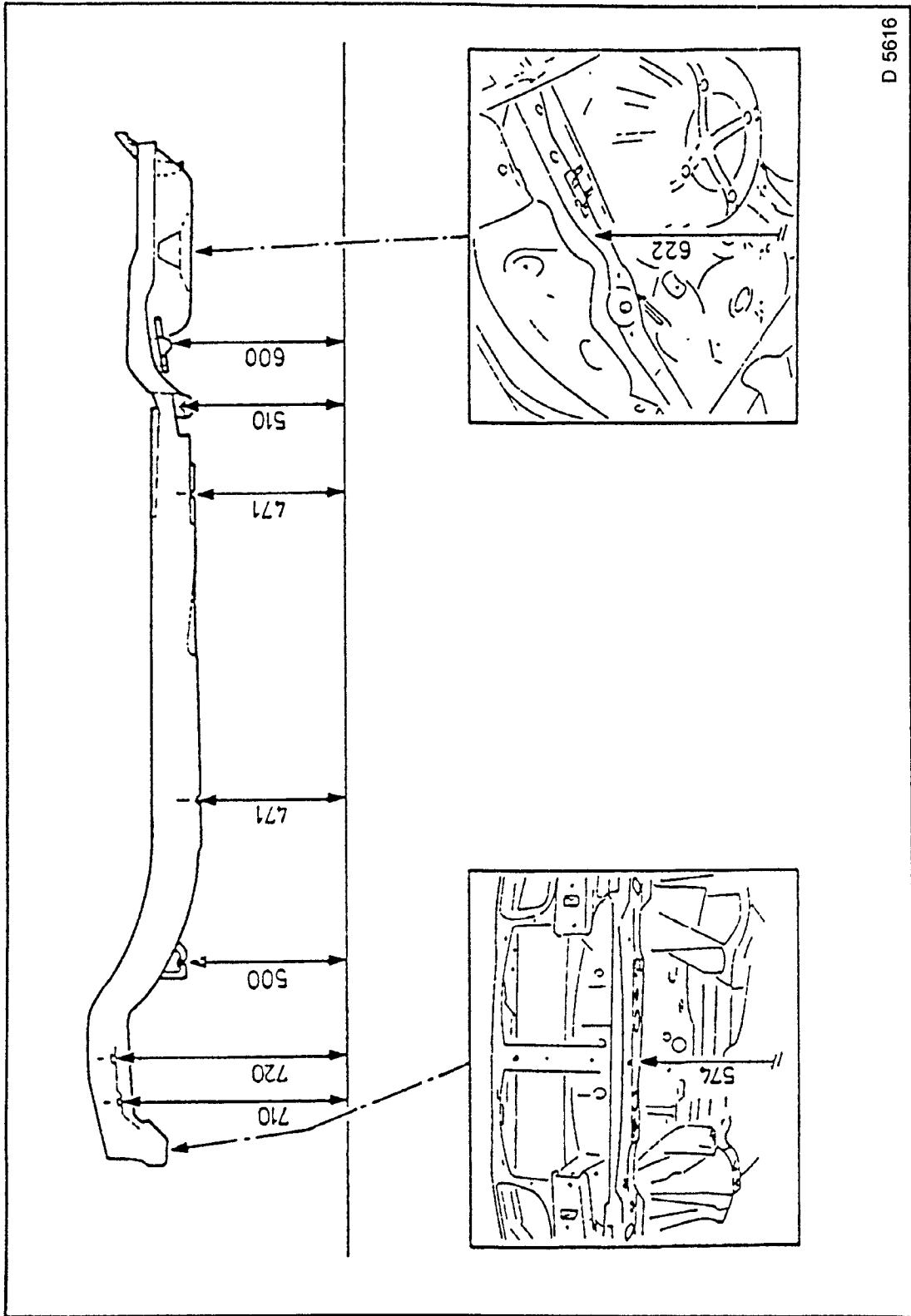


FIG. 7 — LEFT SIDE MEMBER — ON FRONT AXLE BODY WITH SHORT OUTRIGGER

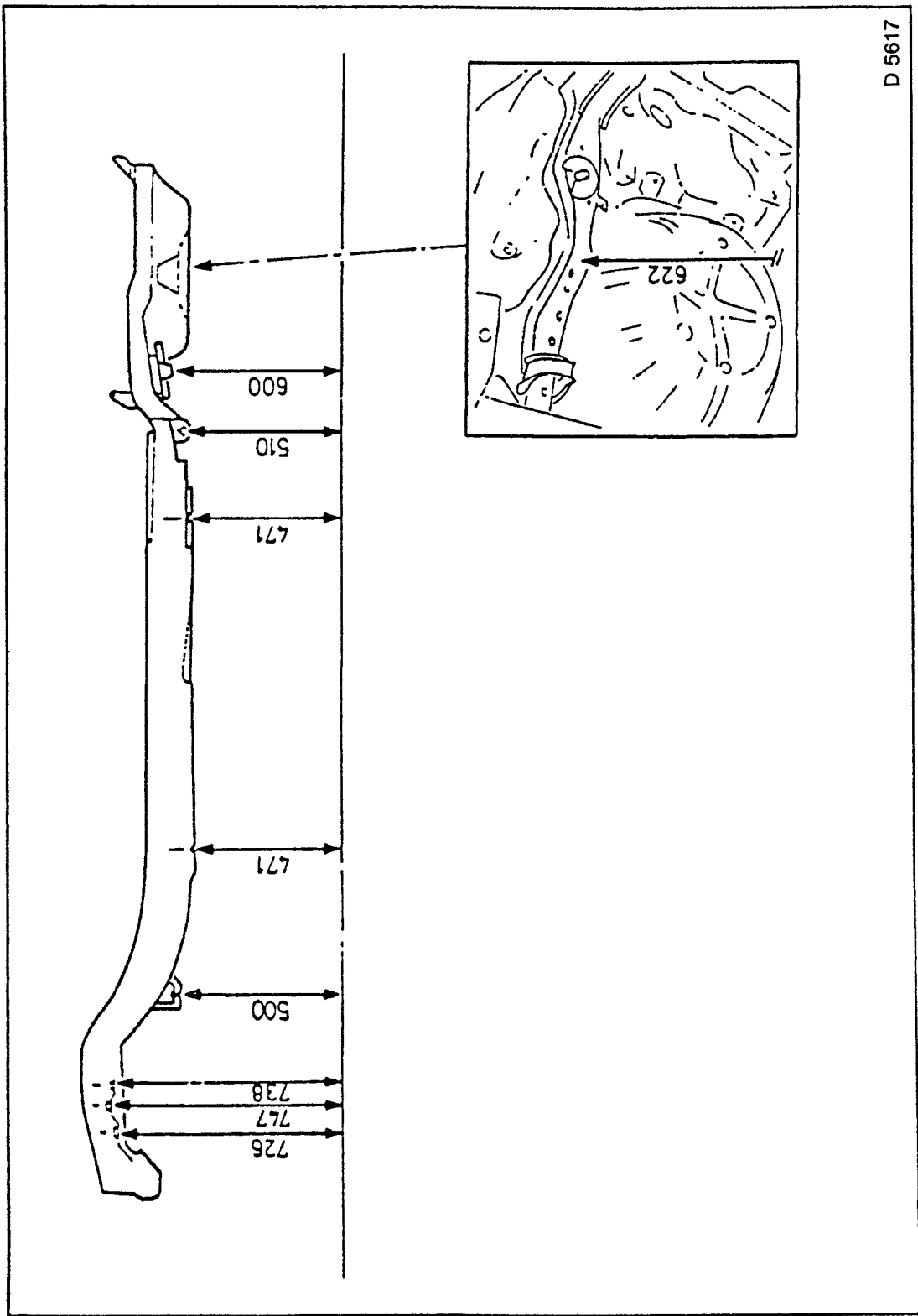


FIG. 8 -- RIGHT SIDE MEMBER -- ON FRONT AXLE BODY WITH SHORT OUTRIGGER

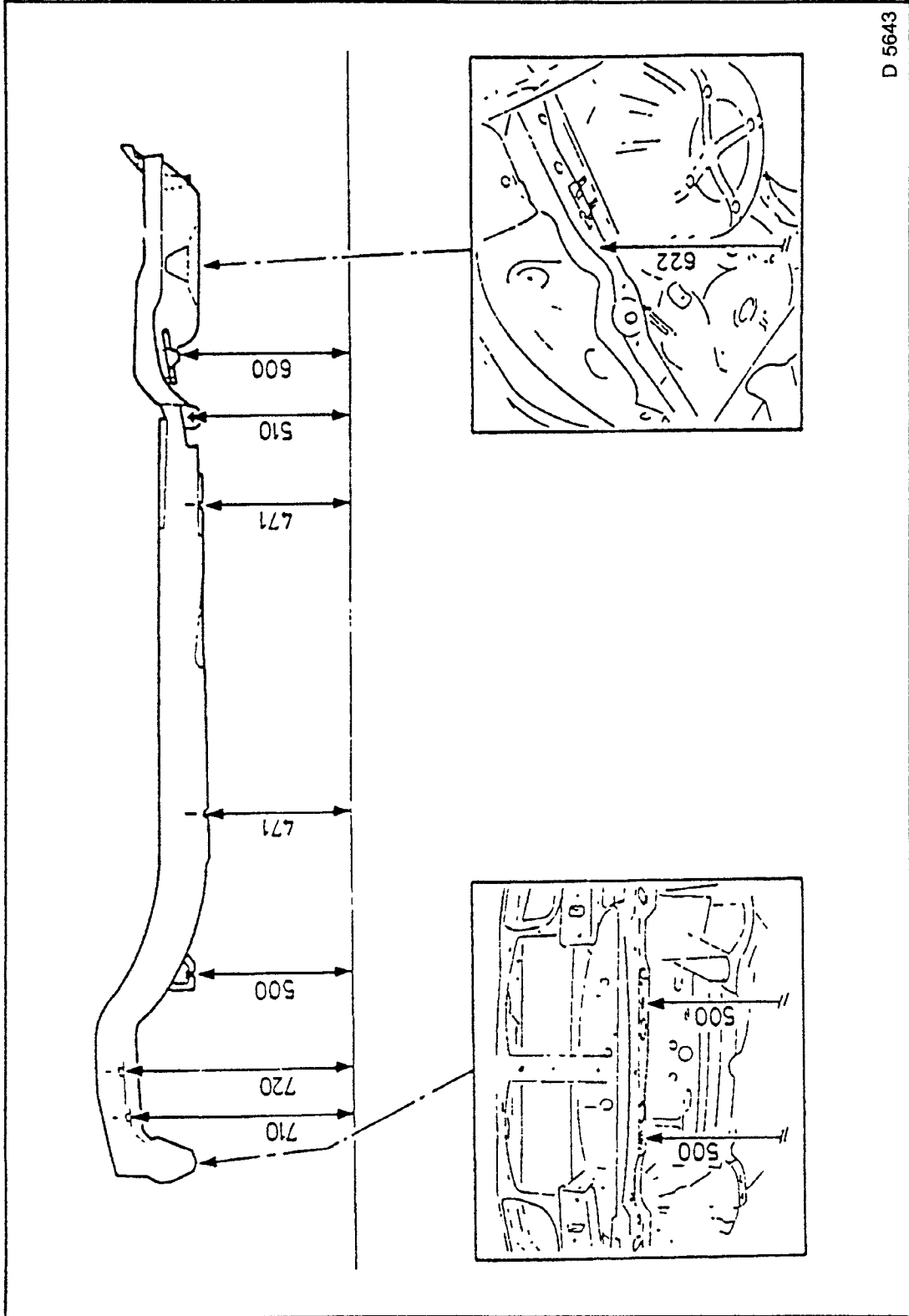


FIG. 9 — LEFT SIDE MEMBER — ON FRONT AXLE BODY WITH LONG OUTRIGGER

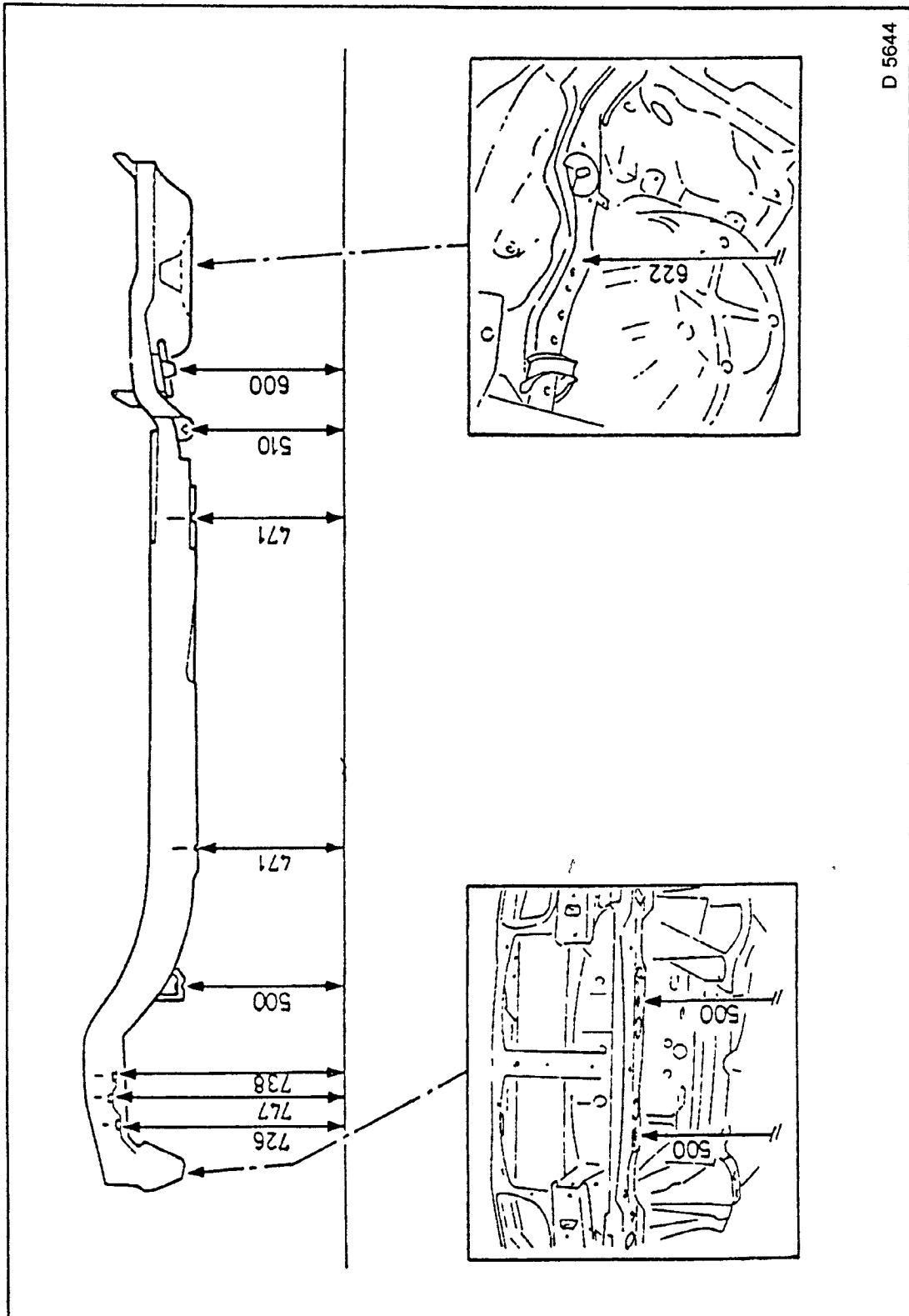
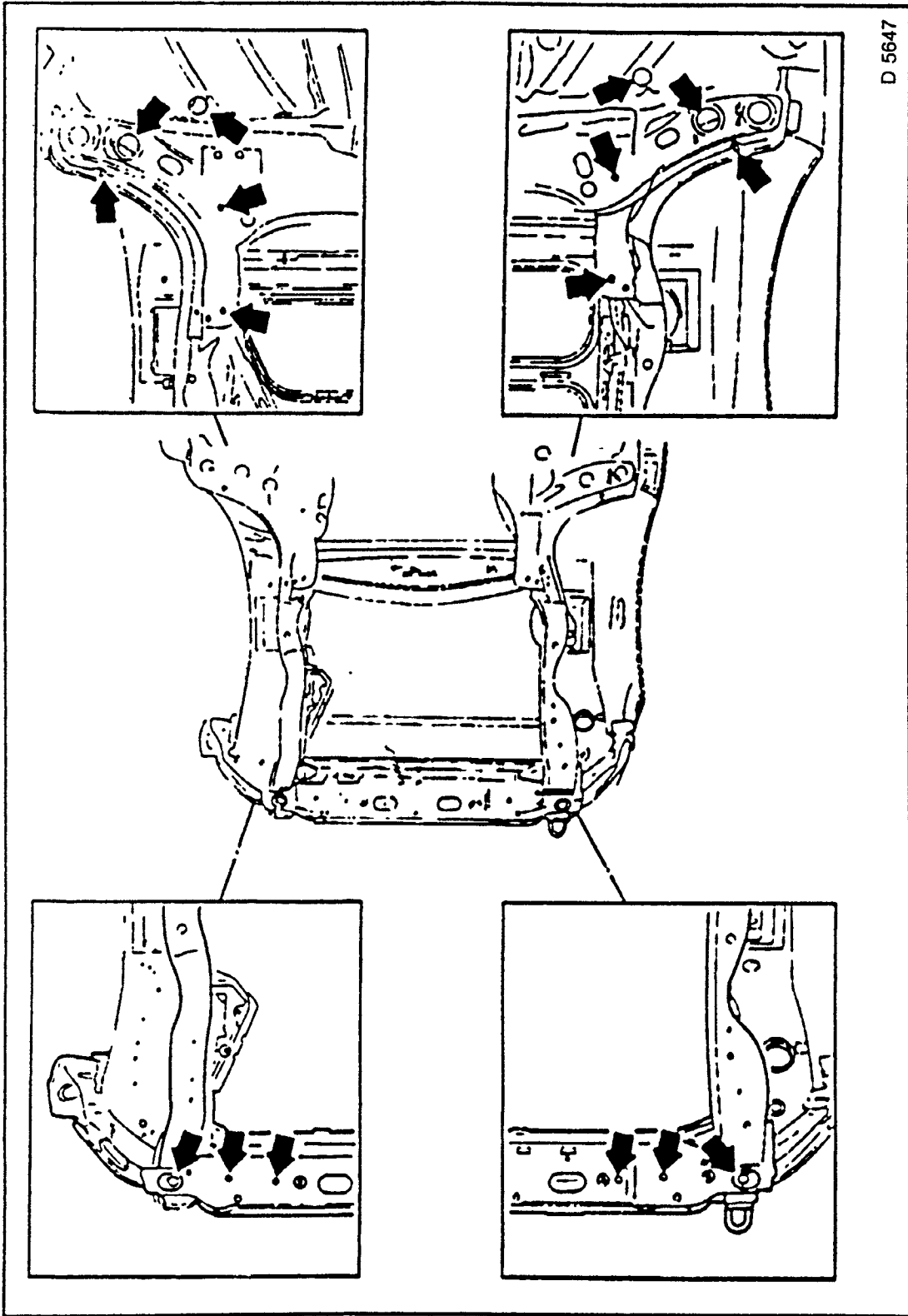
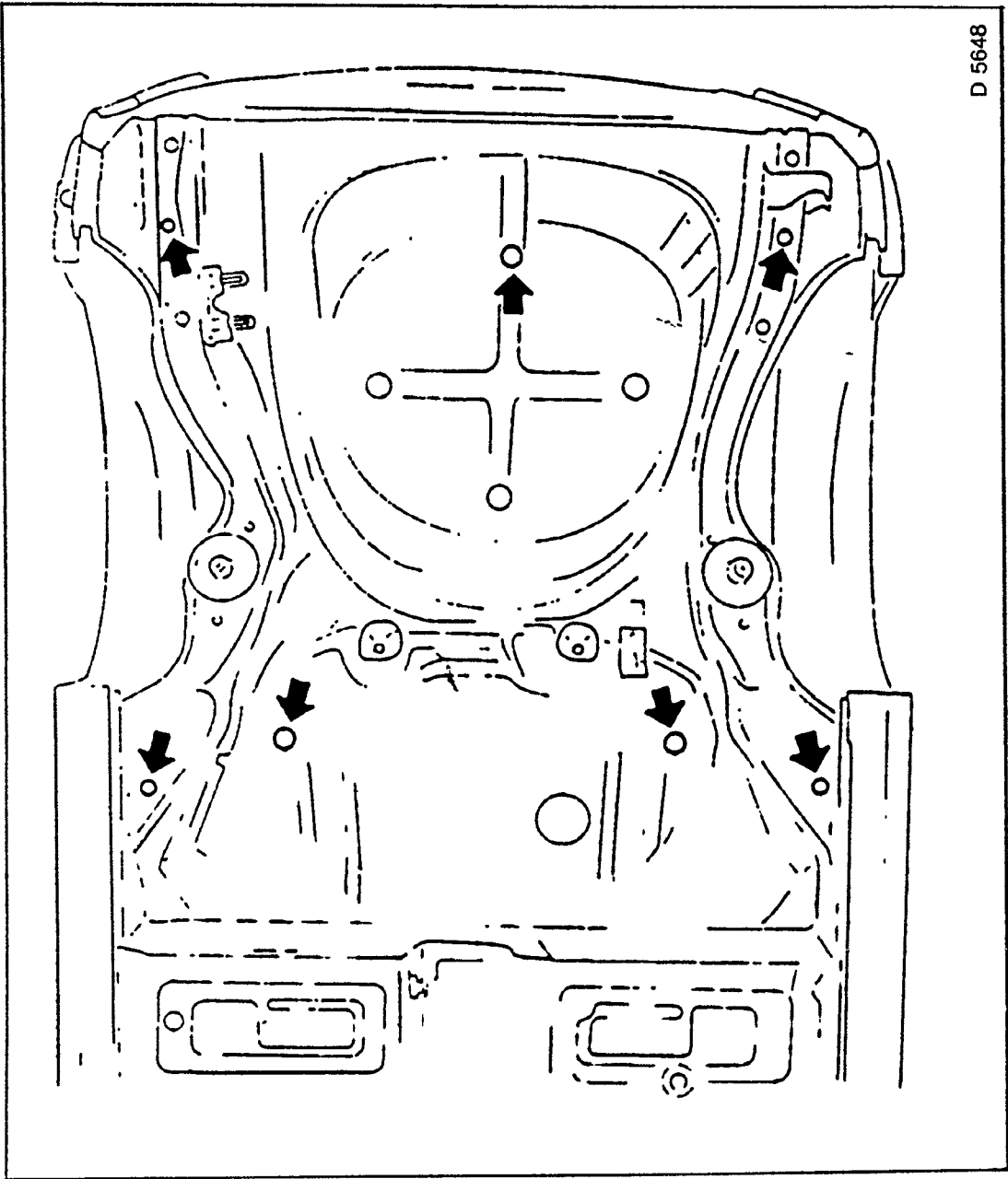


FIG 10 — RIGHT SIDE MEMBER — ON FRONT AXLE BODY WITH LONG OUTRIGGER



D 5647

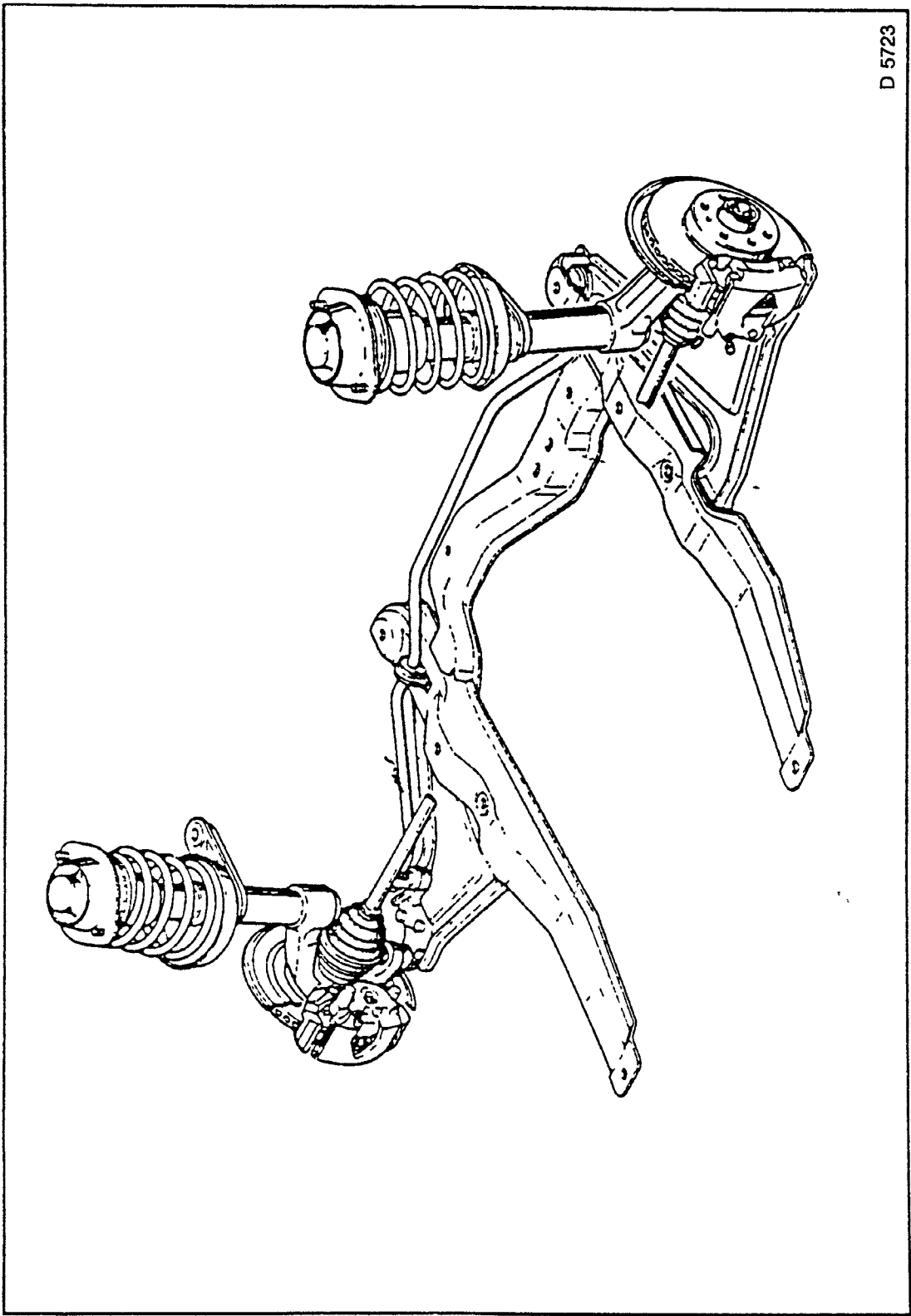
FIG. 11 — VEHICLE FRONT — MOUNTING POINTS



D 5648

FIG. 12 — VEHICLE REAR — MOUNTING POINTS





D 5723

Fig. 13 — FRONT AXLE (WITH LONG OUTRIGGER)

# FRONT WHEEL SUSPENSION

## General Information

When removing the front wheels, mark the position in relation to the hub to assist when installing. Installation must always be carried out with the prescribed torque.

On threaded connections which are inserted with locking compound, the thread must be re-cut. If the new screws are not microencapsulated they must be inserted with Locking Compound.

Operational steps which are not explained can be taken from the corresponding operation.

Ensure that no dirt enters between brake disc and front wheel hub during installation. Contact surfaces must be smooth and free of burrs.

Always replace front springs/spring strut cartridges in pairs.

Use spring strut cartridges from the same manufacturer.

All operations must be carried out at the technician's own responsibility according to the regulations of the local authorities regarding health protection, accident prevention and environmental protection.

## CHECKING AND ADJUSTING OPERATIONS

### Camber, Caster and Toe-out — Check

#### IMPORTANT

1. Uniform and good tyre tread profile.
2. Adjust tyre pressures for full load, same on both sides — see Technical Data for ratings.
3. All wheel rims must be in good condition.
4. There must be no play in the ball joints (tie rod joints and guiding joints).
5. Bring vehicle into checking position.
6. Load each front seat with 70 kg.
7. Half fill fuel tank.
8. Rock vehicle several times.  
If this procedure is omitted, an excessive camber angle will be measured, since the lower control arm **will not** have attained its normal operating position.
9. When using axle measuring unit with turntables, which record no lateral forces, the vehicle must first be rolled back 1 m and then pushed forward again.
10. Position steering for driving straight ahead (see operation "Toe-out, Adjust").
11. Establish actual values on axle measuring equipment (prescribed values see "Technical Data").  
The user instructions and manufacturer's specifications are to be observed.
12. Fill out axle measuring card

## Toe-out — Adjust

### INSPECT

1. Straight ahead position.  
Reference dimension "1" = 325 mm

### MEASURE

1. Place Checking Gauge KM-476 between tie rod ends and left steering housing fastening offset.
2. Hold steering wheel in this straight ahead driving position.

### NOTE:

The clamp bolt for the steering spindle flange must rest on top horizontally, the steering wheel spokes must be centred and slanted downwards. Correct, if necessary.

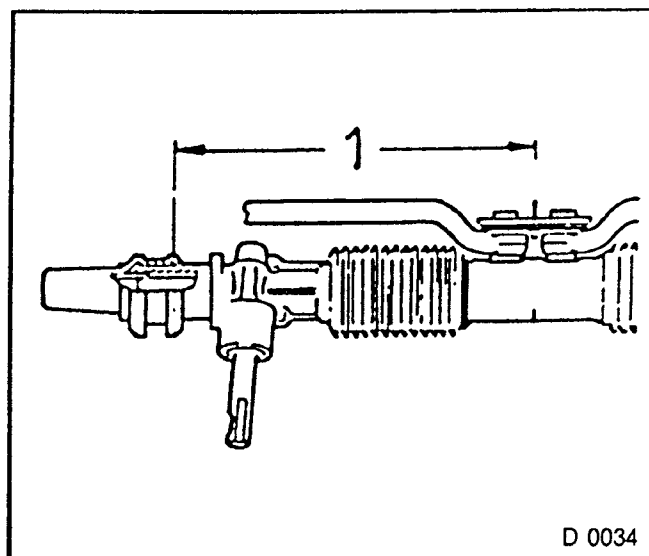


Fig. 14

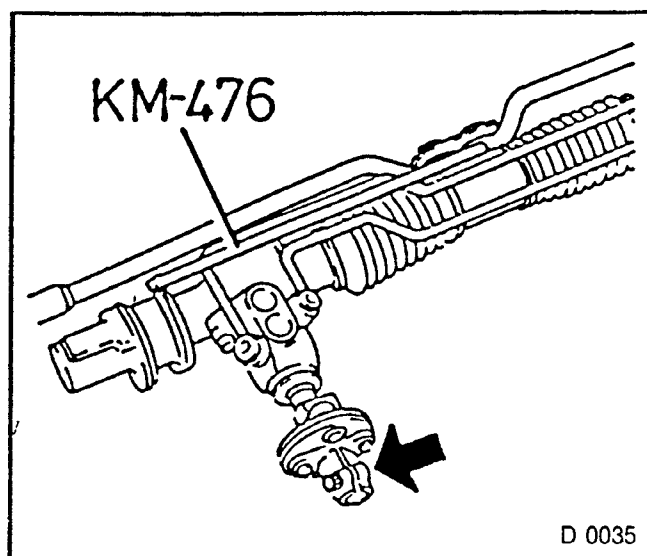


Fig. 15

### ADJUST

1. Toe-out on adjusting bolts.  
For recommended values see "Technical Data".  
Always carry out adjustment on both tie rods.  
Permissible difference in length of tie rods = 5 mm.

### TIGHTEN (TORQUE)

1. Clamp bolts of both tie rods — 20 Nm.  
Check toe-out adjustment.

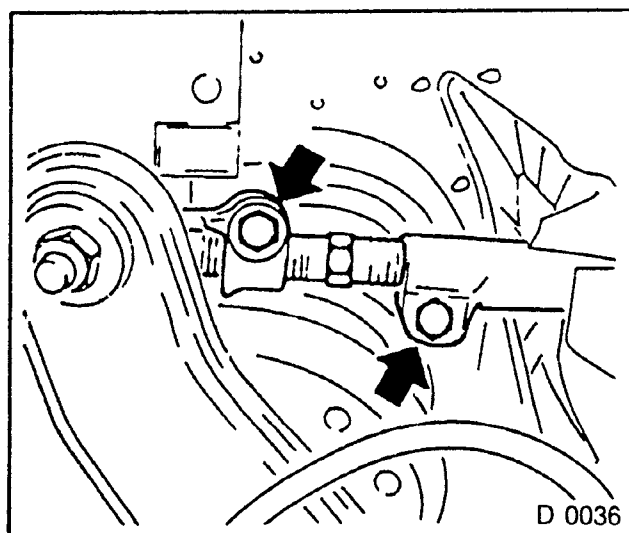


Fig. 16

## AXLE DRIVING SHAFT, WHEEL BEARING, FRONT WHEEL HUB

### Wheel Bearing, Front Wheel Hub — Remove and Install

#### REMOVE, DISCONNECT

1. Spring strut (see page 23)
2. Brake disc — detent screw from front wheel hub.

#### DISASSEMBLE

1. Press off front wheel hub from wheel bearing.
2. Place two flat or square metal bars under spring strut (arrows).
- F10, F13 manual transmission: KM-466-5.  
F16, F20 manual transmission: KM-500-5.
3. Half of the inner bearing ring remains on the front wheel hub.
4. Cover plate from steering knuckle.

#### DISASSEMBLE

1. Retaining rings from steering knuckle (pos. 1 and 2)

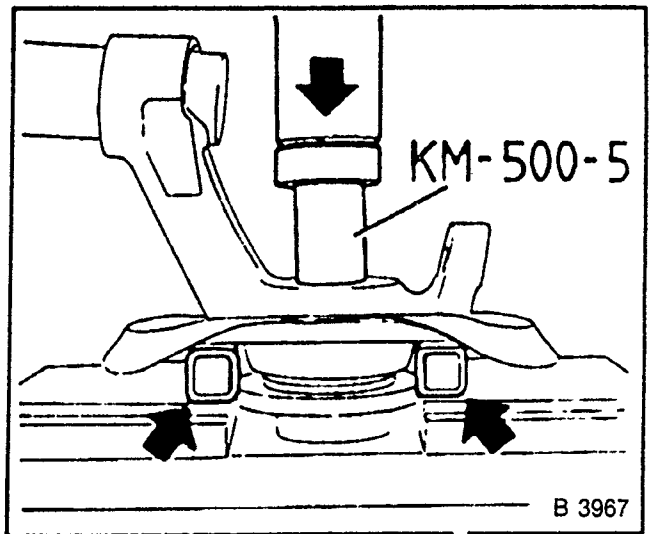


Fig. 17

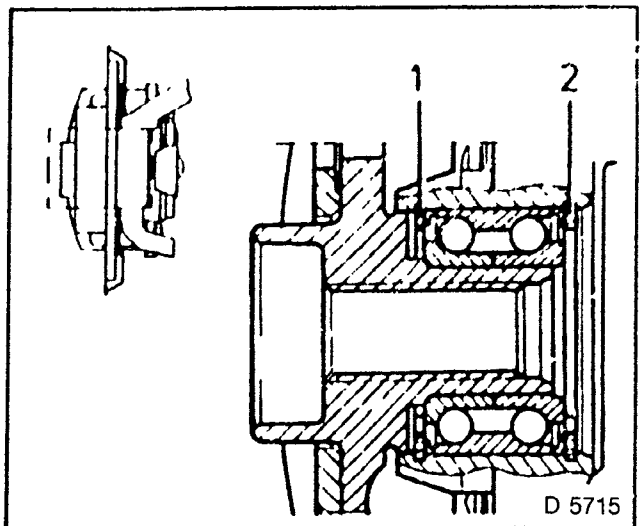


Fig. 18

**DISASSEMBLE**

1. Press wheel bearing out of steering knuckle  
 F10, F13 manual transmission: KM-466-2, KM-466-4 and KM-466-5.  
 F16, F20 manual transmission: KM-500-2, KM-500-4 and KM-500-5.

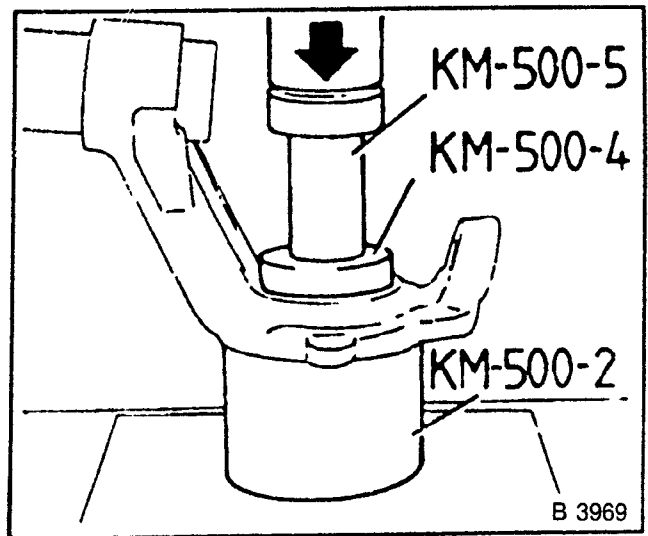


Fig. 19

**IMPORTANT**

Using Remover Tools KM-466-4 and KM-500-4, shorten through surface grinding on the heel on bearing side by 1 mm.  
 New tools have been modified accordingly.

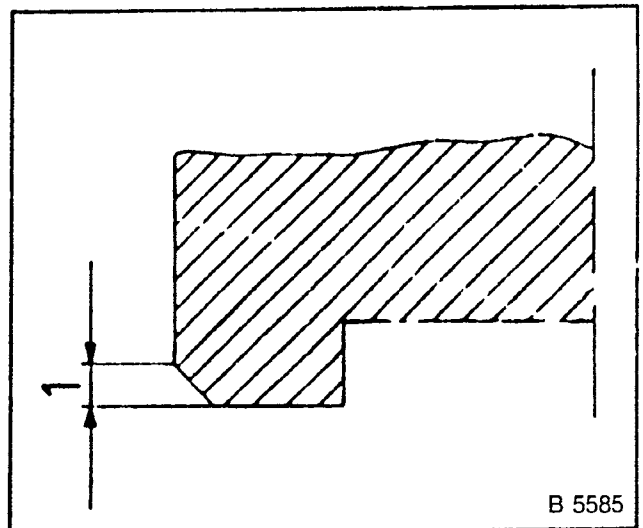


Fig. 20

**DISASSEMBLE**

1. Inner bearing ring from front wheel hub  
 F10, F13 manual transmission: KM-466-1-A.  
 F16, F20 manual transmission: KM-500-1-A.

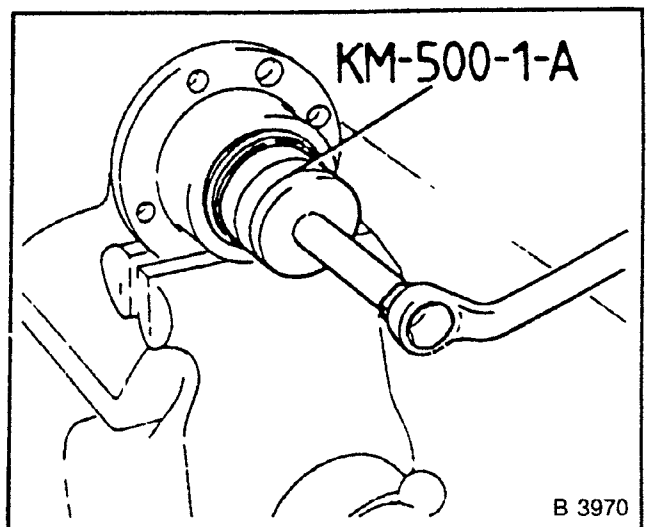


Fig. 21

**ASSEMBLE**

1. Outer retaining ring in steering knuckle.  
The locking tabs of the ring must face downwards to prevent moisture accumulating.
2. Press new wheel bearing up to stop in retaining ring in steering knuckle.  
F10, F13 manual transmission: KM-466-4 and KM-466-5.  
F16, F20 manual transmission: KM-500-4 and KM-500-5.

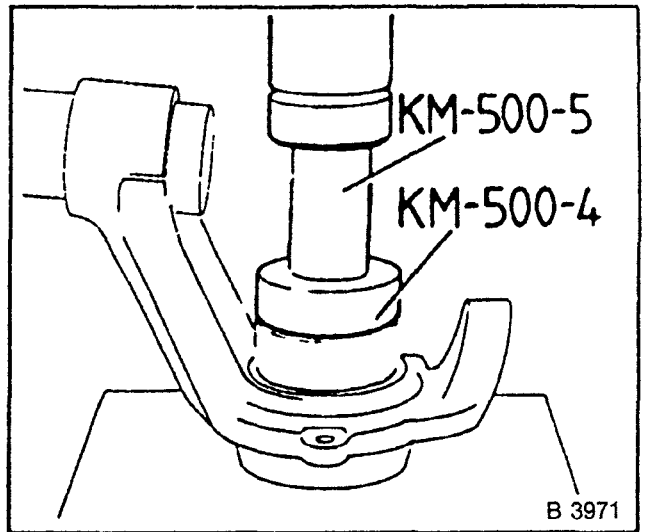


Fig. 22

**TIGHTEN (Torque)**

1. Cover plate to steering knuckle — 4 Nm.

**ASSEMBLE**

1. Inner retaining ring in steering knuckle  
The locking tabs of the ring must face downwards.
2. Front wheel hub in wheel bearing  
F10, F13 manual transmission: KM-466-3 and KM-466-5.  
F16, F20 manual transmission. KM-500-3 and KM-500-5.

**TIGHTEN (Torque)**

- 1 Brake disc to front wheel hub — 4 Nm.

**INSTALL, CONNECT**

1. Spring strut.  
See operation "Spring Strut, Remove and Install" Page 23.

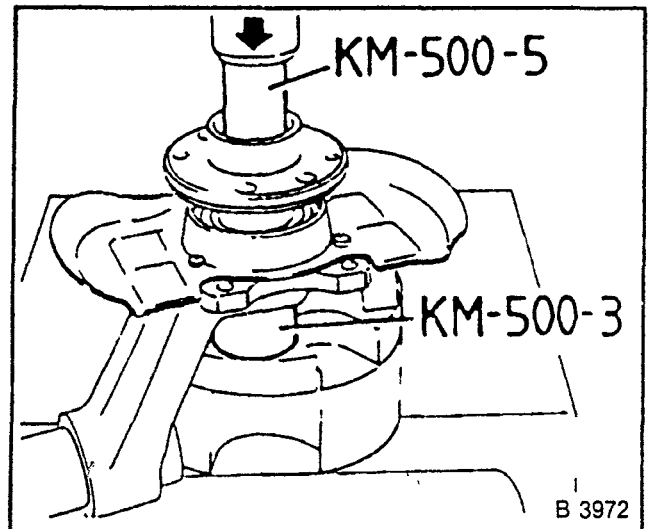


Fig. 23

## Axle Driving Shaft, Remove and Install Completely

### WARNING

1. After an accumulation of approximately 80 000 km the axle driving shaft may only be replaced as an assembly. With collapsed folding cover, do not remove axle driving shaft.
2. Remove small clamp, inflate folding cover and secure again with new clamp. On the right axle driving shaft there is a two-part axle shaft weight (not on all vehicles).  
When installing, maintain distance (1) = 268 to 270 mm from offset of folding cover fastening for outer joint (2).

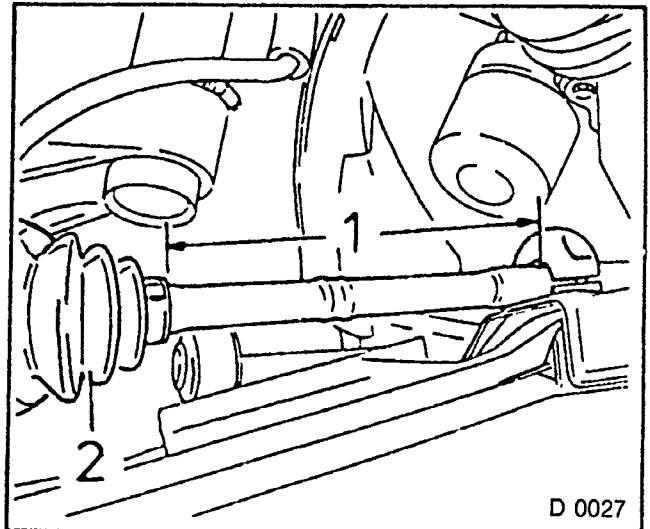


Fig. 24

### REMOVE, DISCONNECT

1. Front wheel.
2. Castellated nut from axle driving shaft. To counterhold, screw KM-468 to front wheel hub.
3. Ball joint from steering knuckle: KM-507-C.
4. Disconnect ABS sensor lead connection in wheel well.
5. "Check Control" sensor from brake lining.

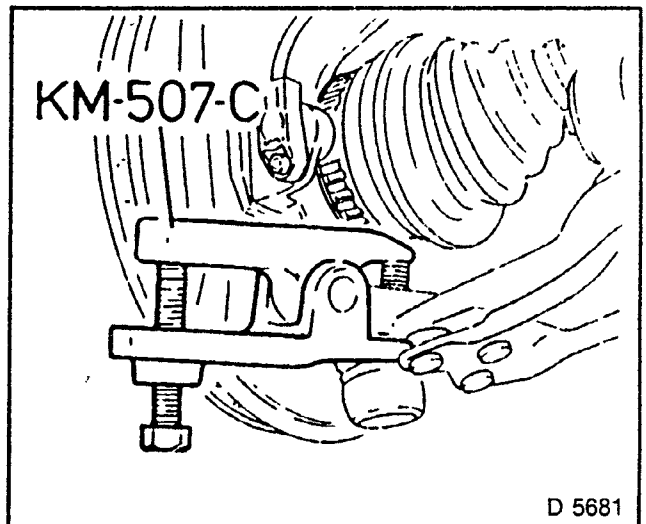


Fig. 25

### REMOVE, DISCONNECT

1. Axle driving shaft from transmission  
F10, F13 manual transmission: left and right KM-460-2-A

**WARNING:**  
FLUID ESCAPES. CLOSE OPENING.  
TIE UP AXLE DRIVING SHAFT.

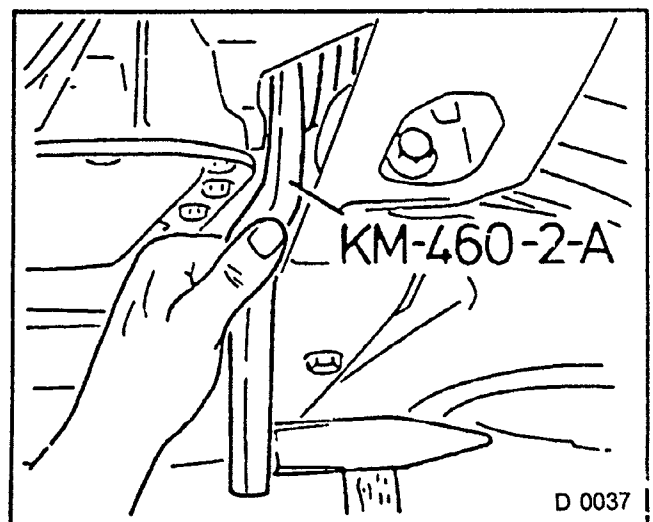


Fig. 26

**REMOVE, DISCONNECT**

1. Axle driving shaft from transmission.

	Left:	Right:
F16	KM-503-A	KM-460-2-A
F20	KM-503-A	KM-460-2-A
AT	KM-503-A	Soft metal drift

**WARNING:**  
**FLUID ESCAPES. CLOSE OPENING.**

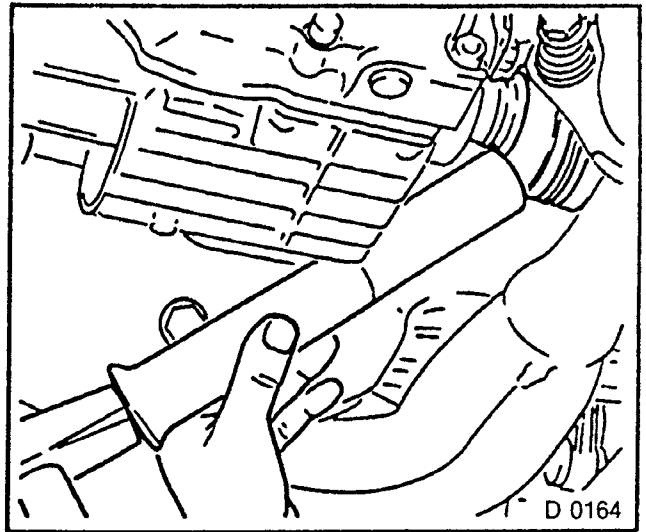


Fig. 27

**KM-503-A(1) at differential cover (2), must not be supported at the tapered roller bearing nut (3).**

**CAUTION:**

On F-20 — left side.

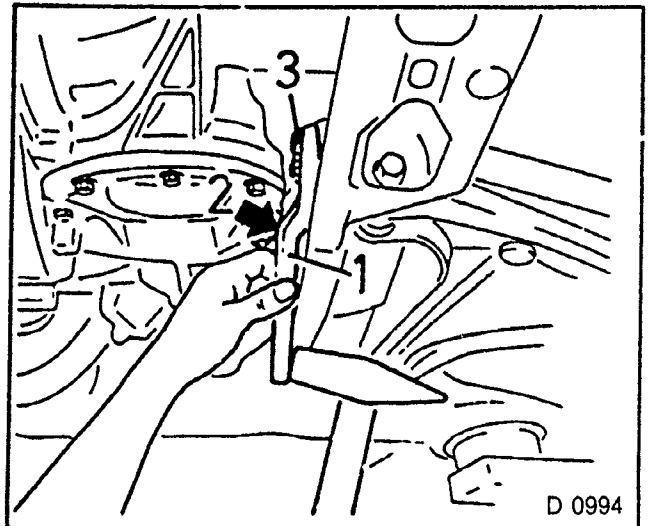


Fig. 28

**REMOVE DISCONNECT**

1. Axle driving shaft from front wheel hub.  
 By hand or with Kukko Wheel Hub Remover No. 38-A.

**CAUTION:**

After removal, do not put weight on wheel bearing or move vehicle any more.  
 If moving the vehicle is unavoidable, insert replacement axle stub shaft in hub and tighten.

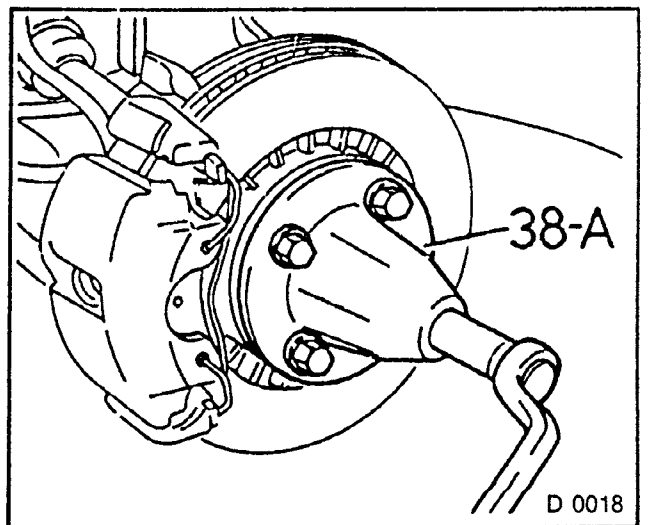


Fig 29



**CAUTION:**

Treat new axle driving shaft carefully.  
Do not lay shaft on folding cover for a long period.

Coat tooting and bearing points with transmission fluid.

When re-using the axle shaft:

Replace retaining ring (1).

When driving in the axle shaft, position the screwdriver at the friction welding seam (2).

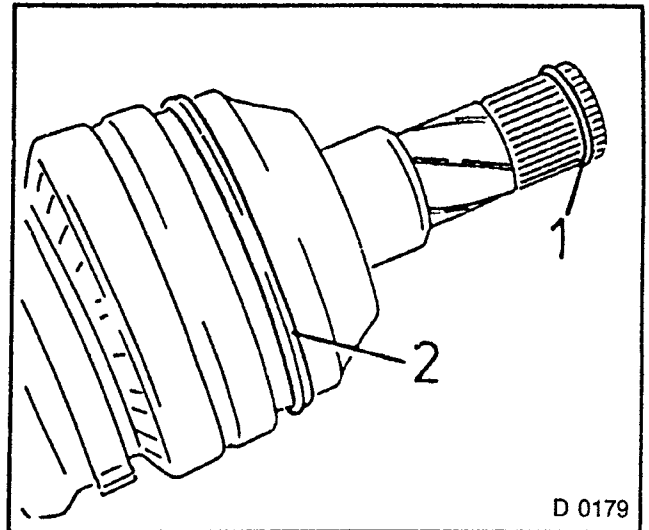


Fig 30

**INSTALL, CONNECT**

1. Axle shaft in front wheel hub.
2. New castellated nut and new washer loosely on shaft.
3. Thoroughly clean contact surfaces of joint to bearing inner ring and axle nut with washer to hub (arrows), to maintain prescribed torque.

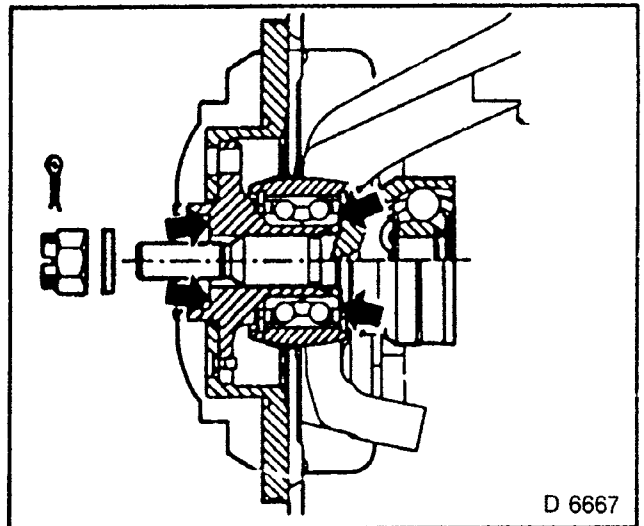


Fig 31

**INSTALL, CONNECT**

1. Axle shaft in transmission.
2. New retaining ring.
3. Drive in with suitable drift until retaining ring engages.
4. Check that joint is firmly seated by pulling on outer diameter of joint by hand.

**TIGHTEN (Torque)**

1. Ball joint to steering knuckle — 70 Nm.
2. Use new retaining clamp and new nut.

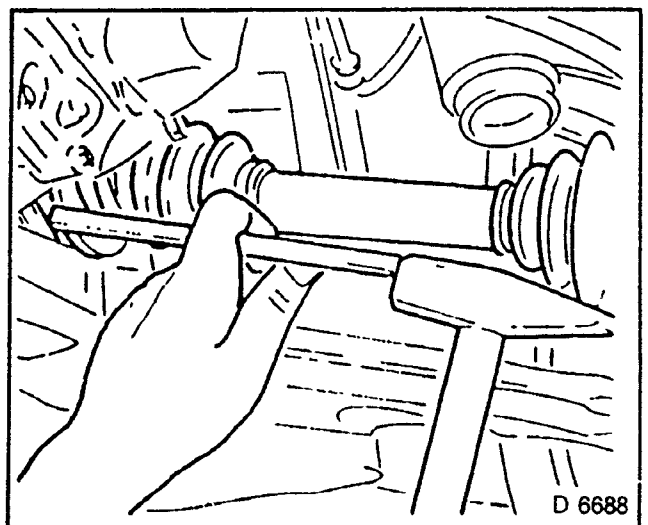


Fig 32

**TORQUE — ANGLE METHOD**

1. Push axle shaft wheel journal through hub.
2. Install washer with nut.
3. Tighten nut to 100 Nm and loosen again.
4. Tighten again to 20 Nm, then turn nut a further 80°.

If in this position no castellated nut groove aligns with a cotter pin hole, turn nut up to 9° further and secure with pin. Counterhold with KM-468.

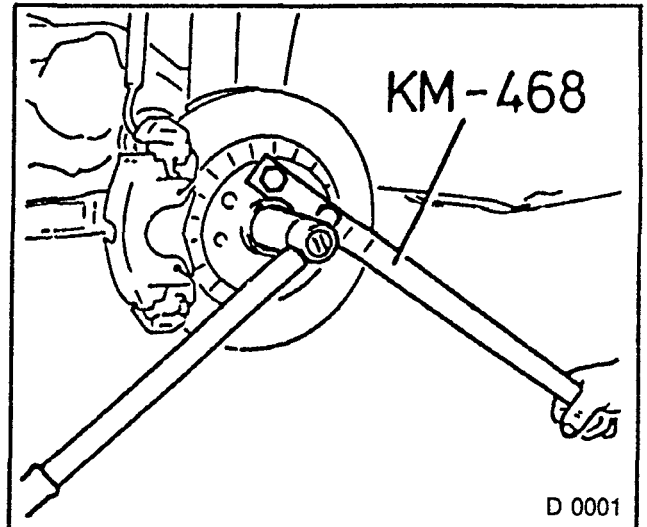


Fig. 33

**TIGHTEN (Torque)**

1. Recut threaded bore hole — M12 x 1,5.
2. Brake caliper to steering knuckle.

**CAUTION:**

1. Ensure that brake hose is routed without twisting.
2. Insert new bolts with Locking Compound and tighten to 95 Nm.
3. Wheel bolts — 110 Nm
4. "Check Control" sensor in brake lining.
5. Connect "Check Control" lead connection in wheel well.
6. ABS sensor lead connection.

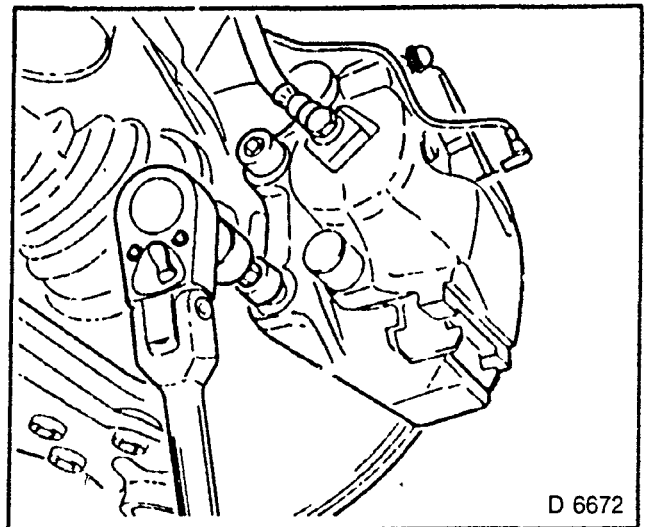


Fig. 34

**INSPECT**

1. Transmission fluid level (see Section K).

## Joint of Axle Driving Shaft — Remove and Install Individually

### REMOVE, DISCONNECT

1. Axle driving shaft  
See operation "Axle Driving Shaft, Remove and Install Completely".  
Page 18.
2. Remove folding cover retaining band from joint and turn up.
3. Pull apart retaining ring in joint with pliers.

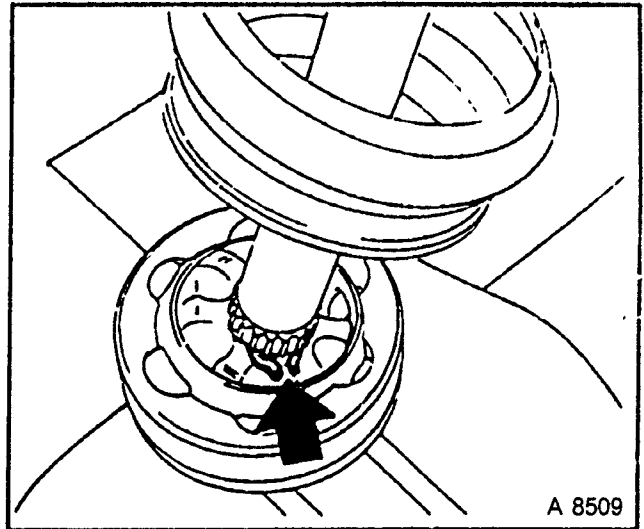


Fig. 35

### REMOVE, DISCONNECT

1. Joint from shaft teeth with plastic hammer.
2. Joint is replaced as an assembly only.  
Wash out cavities of joint and fill with Special Grease.

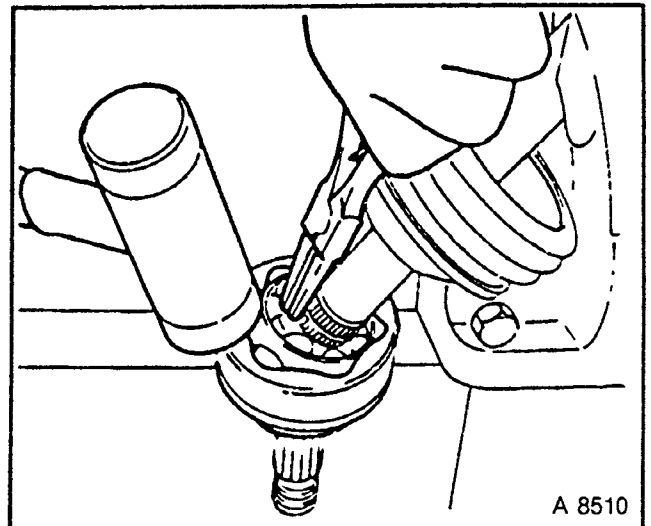


Fig. 36

### INSTALL, CONNECT

1. New joint on shaft teeth.
2. Use new retaining ring.
3. With plastic hammer until retaining ring locks.
4. Inner joint on long shaft side for folding cover fastening (dimension "1" = 135 mm).
5. Folding cover  
Deflate folding cover — must not be twisted.  
Tension retaining band with Special Clamping Pliers KM-J-22610.
6. Axle driving shaft.

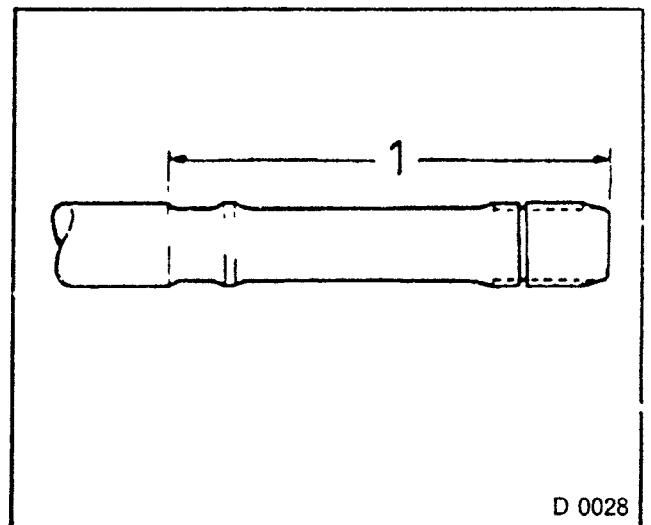


Fig. 37

## Folding Covers of One Axle Driving Shaft — Remove and Install

### REMOVE, DISCONNECT

1. Joint .  
See operation "Joint of Axle Driving Shaft, Remove and Install" page 22.
2. Folding cover.  
When replacing both folding covers remove only one joint.

### INSTALL, CONNECT

1. Folding cover.
2. Joint.

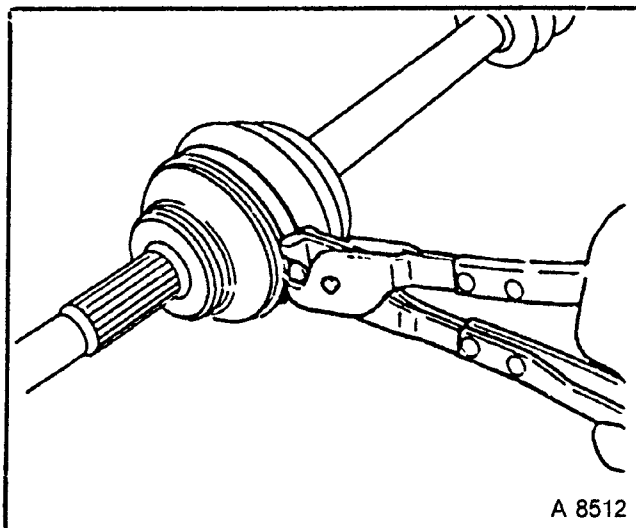


Fig. 38

## SPRING STRUT, CONTROL ARM, STABILIZER, FRONT AXLE BODY

### Spring Strut, Remove and Install

#### REMOVE, DISCONNECT

1. Front wheel.
2. ABS sensor with bracket
3. Brake caliper from steering knuckle.
4. Suspend brake caliper.
5. Castellated nut from axle driving shaft.  
To counterhold screw KM-468 to front wheel hub.

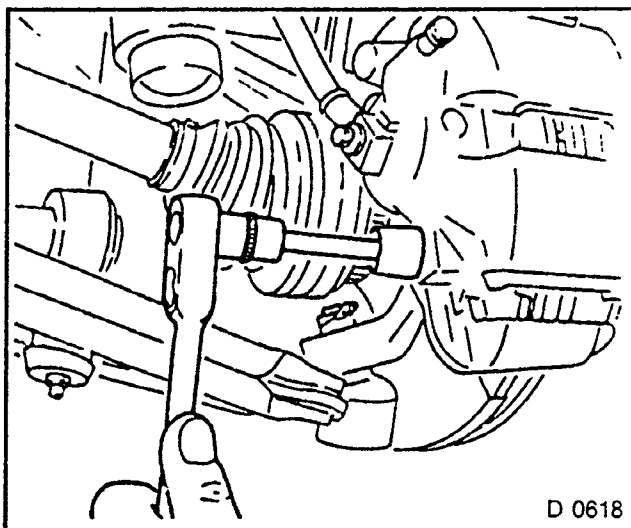


Fig. 39

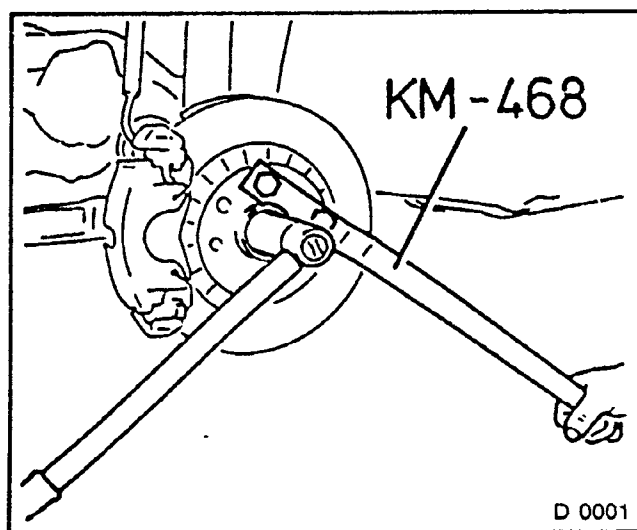


Fig. 40

**REMOVE, DISCONNECT**

1. Tie rod joint from tie rod lever — KM-507-C.
2. Ball joint from steering knuckle using KM-507-C.
3. Axle driving shaft from front wheel hub, by hand or with Kukko Wheel Hub Remover No. 38-A.
4. Tie up axle driving shaft.

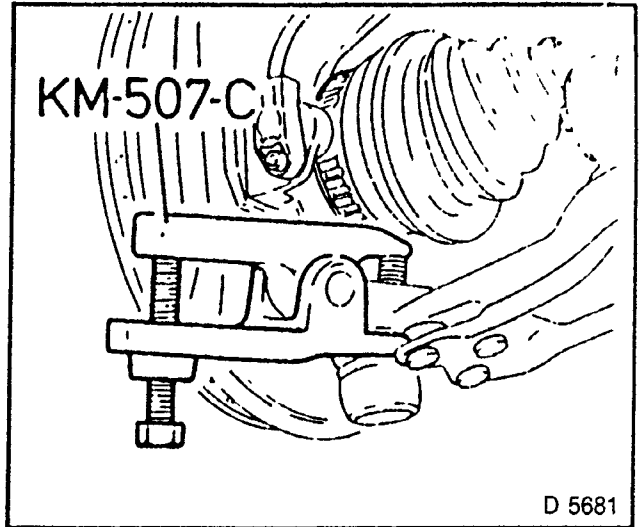


Fig. 41

5. Spring strut from wheel well; loosen two nuts (arrows).

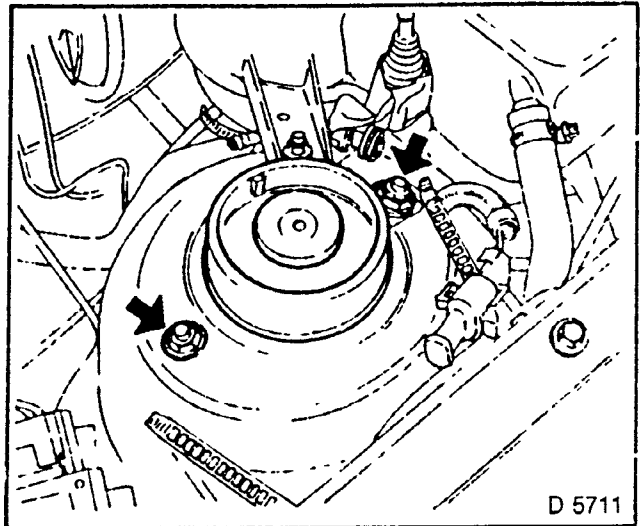


Fig. 42

**Spring Strut, Disassemble****DISASSEMBLE**

1. Tension spring strut in Spring Compressor KM-329-A in conjunction with KM-465-A and Hooks KM-550-31.
2. Tension front spring.  
Note correct seating of hooks.

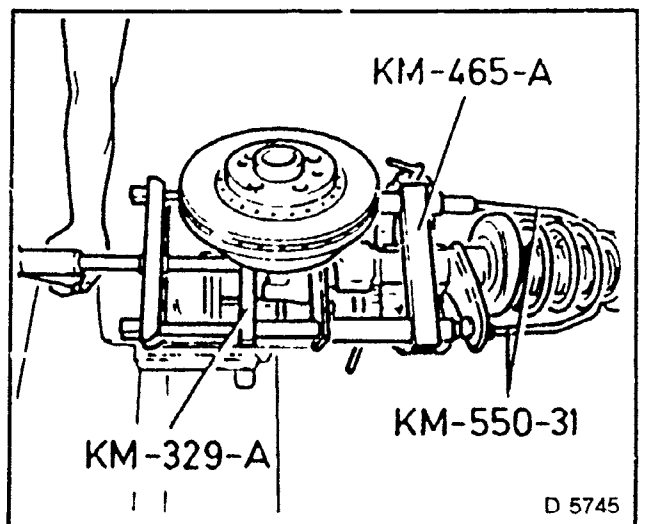


Fig. 43

3. Remove closure plug.
4. Loosen nut from piston rod and while doing so, counterhold piston rod.

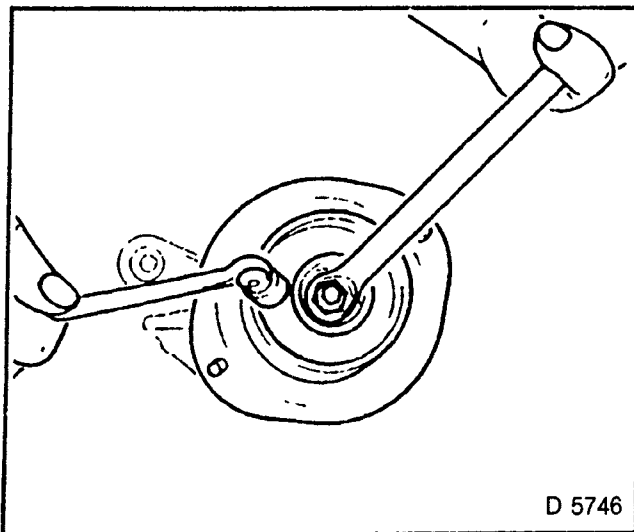


Fig. 44

**DISASSEMBLE**

1. Remove support bearing.
2. Thrust bearing.
3. Dust cap.
4. Damping ring.
5. Stop buffer.  
Check whether they can be re-used.
6. Release tension on front springs and remove.

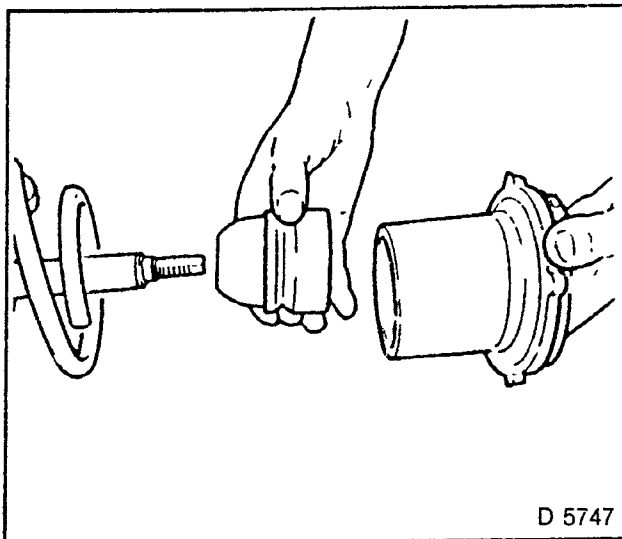


Fig 45

7. Remove threaded ring (plate nut) from carrier tube with KM-563.

**NOTE:  
A HIGH LOOSENING TORQUE IS  
NECESSARY.**

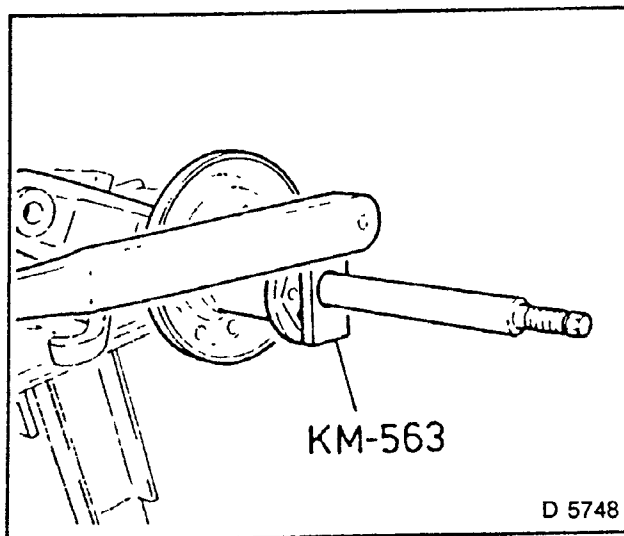


Fig. 46

## Support Bearing — Remove and Install Front Spring and/or Damper Rings — Remove and Install

1. Remove spring strut and disassemble (see page 24).

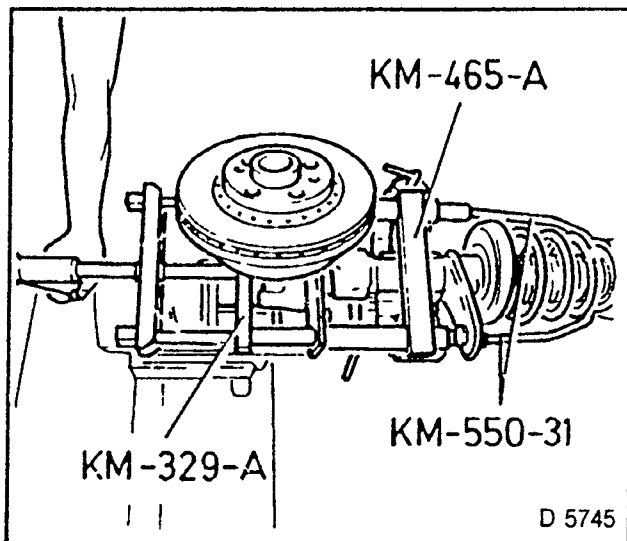


Fig. 47

### DISASSEMBLE

Spring strut — see Fig. 48

- 1 — Support bearing
- 2 — axial bearing
- 3 — dust cap with upper damper ring
- 4 — stop buffer
- 5 — spring
- 6 — lower damper ring

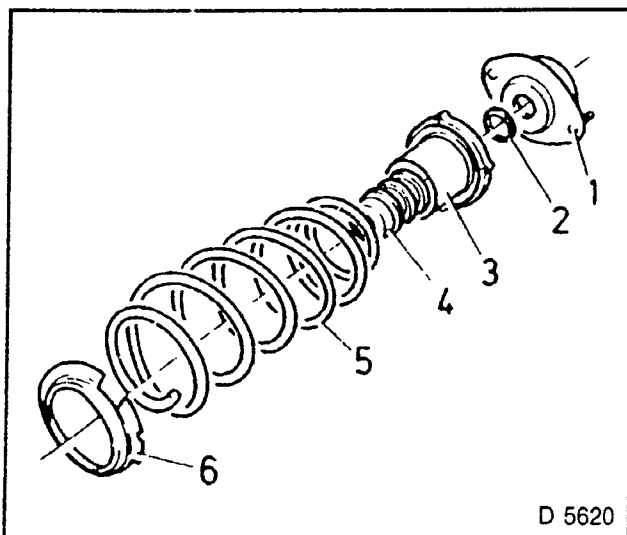


Fig. 48

### INSPECT

Removed parts to see if they can be re-used.

### ASSEMBLE

Single parts of spring strut — in reverse order 6 to 1.

### NOTE:

1. Mount stop buffer (4) with the even side towards spring.
2. Mount axial bearing (2) with smaller circumference side towards spring.

### INSTALL, CONNECT

1. Spring strut to control arm and wheel housing.
2. Brake caliper to steering knuckle.

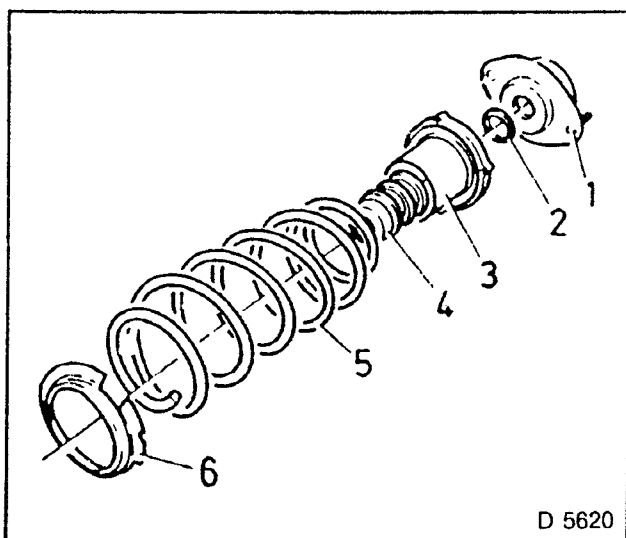
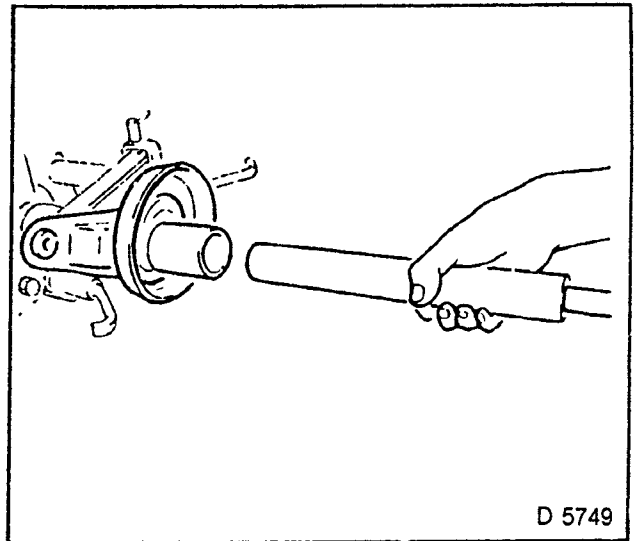


Fig. 49

## Spring Strut Cartridge — Remove and Install

### DISASSEMBLE

1. Remove spring strut from spring compressor.  
When replacing the spring strut:  
Front wheel hub from steering knuckle.  
Damper ring from lower spring plate.  
See operation "Front Wheel Hub, Remove and Install". Page 15.

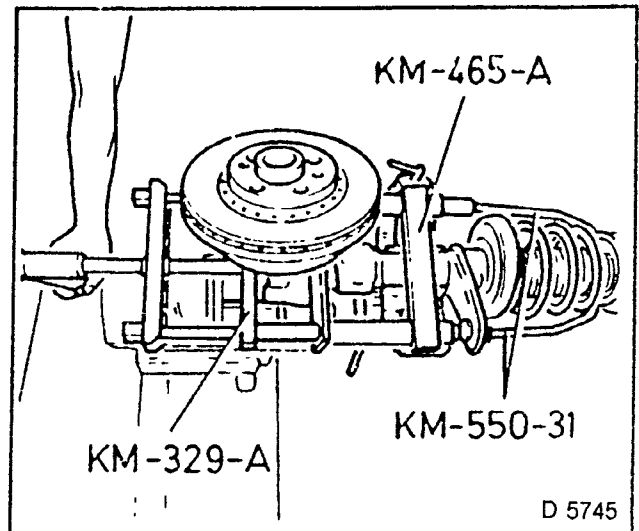


D 5749

Fig. 50

### ASSEMBLE

1. New wheel bearing and front wheel hub in spring strut. See operation "Wheel Bearing, Remove and Install". Page 15.
2. Spring strut cartridge.
3. Tension spring strut in spring compressor.

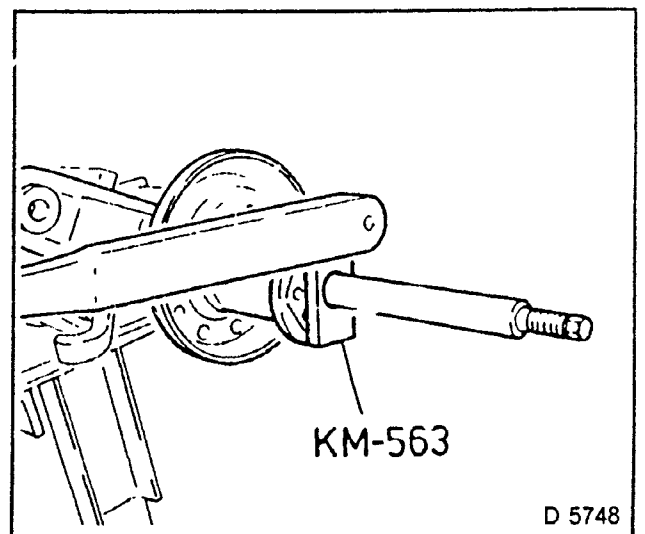


D 5745

Fig. 51

### TIGHTEN (Torque)

1. Threaded ring to carrier tube — 200 Nm.  
DO NOT remove wax coating. Maintain shown 90° position of torque wrench relative to KM-563.



D 5748

Fig. 52



**ASSEMBLE**

1. Front spring from spring strut.
2. Place spring end with damper ring in stop of spring collar.
3. Tension spring.
4. Stop buffer on piston rod.

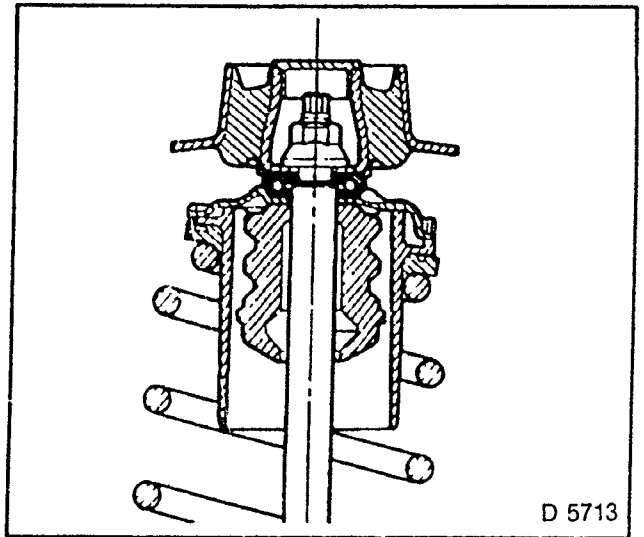


Fig. 53

**ASSEMBLE**

1. Dust cap with damper ring on piston rod.

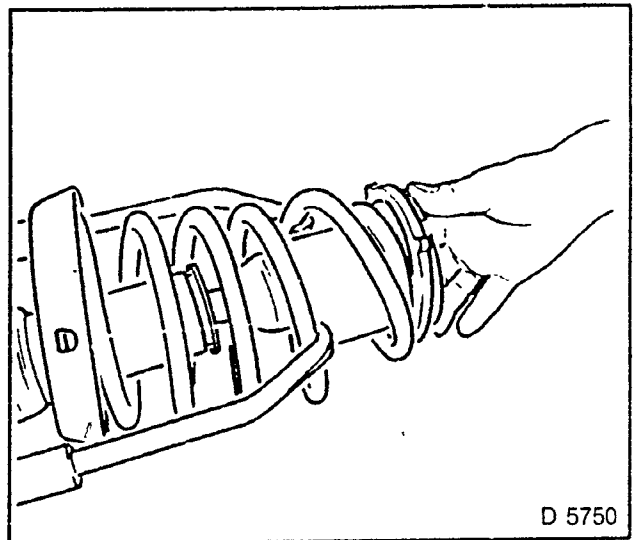


Fig. 54

**TIGHTEN (Torque)**

1. Piston rod to support bearing — 55 Nm.
2. Crosshold at piston rod of spring strut cartridge.
3. Release spring

**NOTE:**  
**CHECK FOR PERFECT POSITIONING OF DAMPER RING.**  
**REMOVE SPRING STRUT FROM SPRING COMPRESSOR.**

**TIGHTEN (Torque)**

1. Spring strut to wheel housing — 30 Nm.

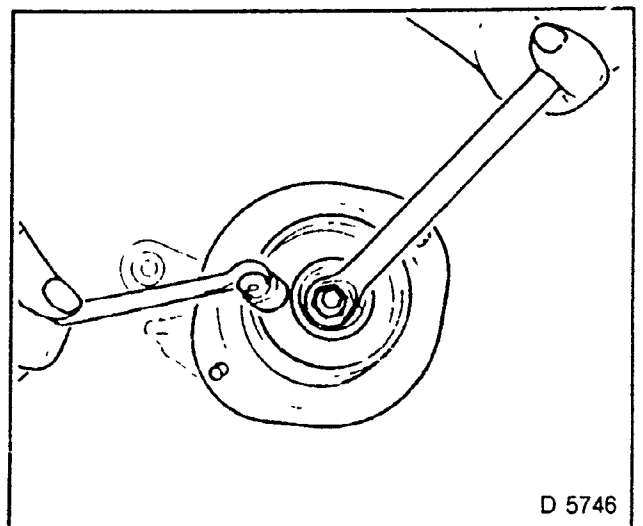


Fig. 55

**INSTALL, CONNECT**

1. Axle shaft to front wheel hub.  
See operation "Axle Shaft, Remove and Install Completely". Page 18.

**TIGHTEN (Torque)**

1. Ball joint to steering knuckle — 70 Nm.
2. Use new retaining clamp (arrow) and new nut.
3. Tie rod joint to tie rod lever — 60 Nm.

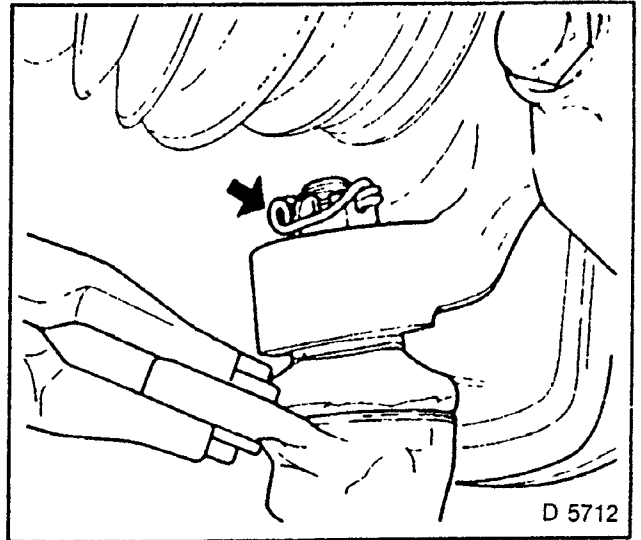


Fig 56

4. Brake caliper to steering knuckle — 95 Nm.
5. Wheel bolts — 110 Nm.

**ADJUST**

1. Air play — brake lining.  
By fully depressing the brake pedal several times.

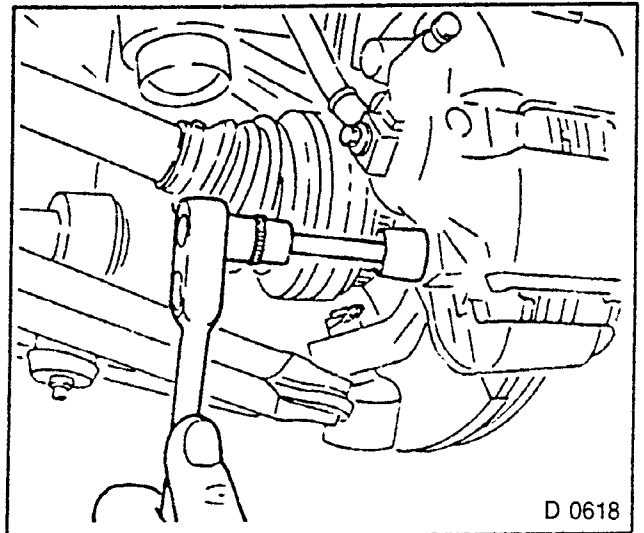


Fig 57

**Control Arm —  
Remove and Install**

**REMOVE, DISCONNECT**

1. Stabilizer from control arm.
2. Ball joint from steering knuckle  
KM-507-C

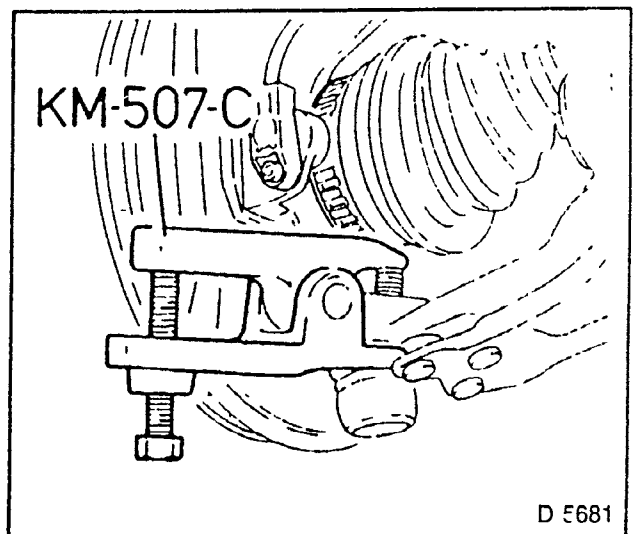


Fig. 58

3. Control arm from front axle body front and rear.
4. Press out control arm from mounting lever.  
Existing mounting sleeves (arrows) in rear damping bush are not applicable when installing.

**CAUTION:**  
WHEN REPLACING THE RIGHT CONTROL ARM CONVERT COMPENSATING WEIGHT.

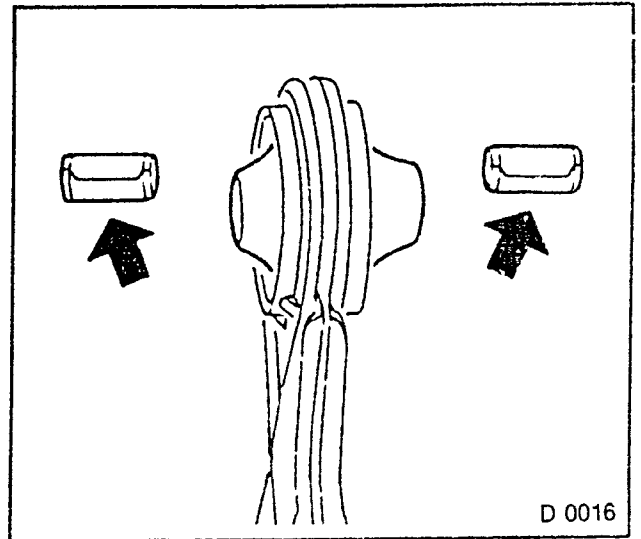


Fig. 59

### TIGHTEN (Torque)

1. Control arm to front of front axle body — 100 Nm + 60° to 70°.
2. Control arm with front axle body to support — 170 Nm.
3. Control arm in horizontal position.

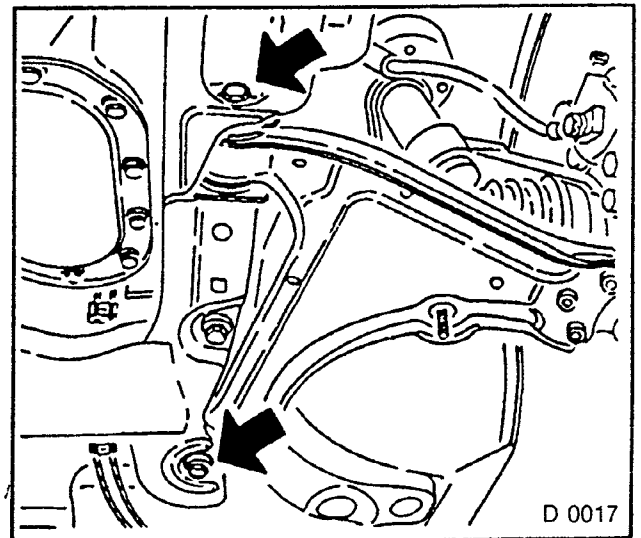


Fig 60

### TIGHTEN (Torque)

1. Ball joint to steering knuckle — 70 Nm.  
Use new retaining clamp and new nuts.

### INSTALL, CONNECT

1. Stabilizer on control arm.
2. Maintain pre-tension dimension  
"1" = 38 — 39 mm.  
If necessary, replace rubber buffer.
3. Use new Nuts, counterhold with Self-locking Nuts — 20 Nm.
4. Front wheel — 110 Nm.

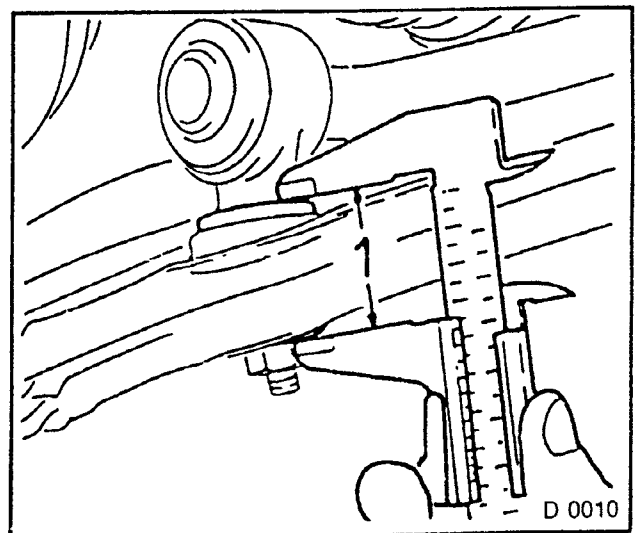


Fig 61

## Damping Bushings in Control Arm — Remove and Install

### REMOVE, DISCONNECT

Control arm — see corresponding page 29.

### DISASSEMBLE

1. Rear damping bushing.
2. Press out with KM-613-1 and KM-613-3 from below upwards, control arm in installation position.

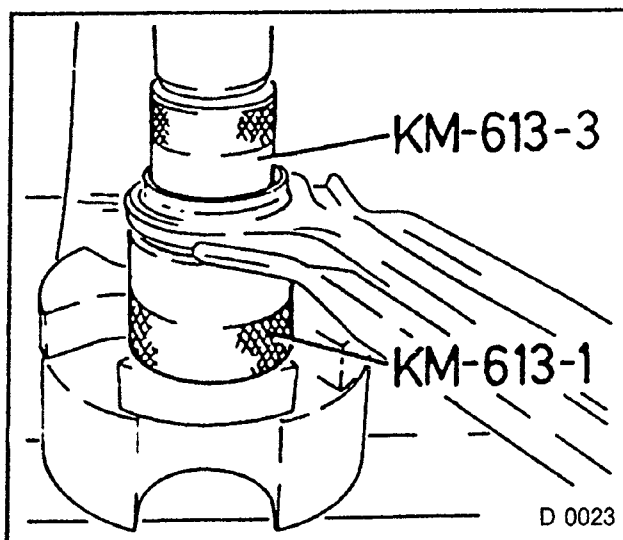


Fig 62

### DISASSEMBLE

1. Front damping bushing  
Press out with KM-508-1 and KM-508-3 from rear to front, control arm in installation position.

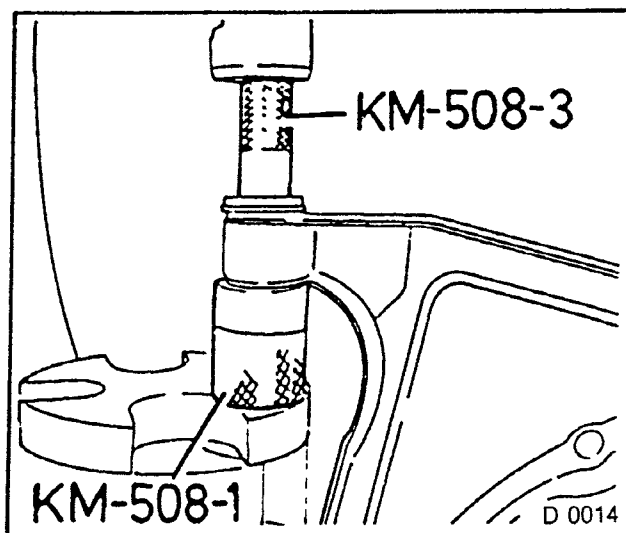


Fig 63

### ASSEMBLE

1. New front damping bushings.  
Press in with KM-508-1, KM-508-2 and KM-508-3 from front to rear, control arm in installation position
2. Soak outer bushing in soapy water  
Same projection of rubber bead on both sides

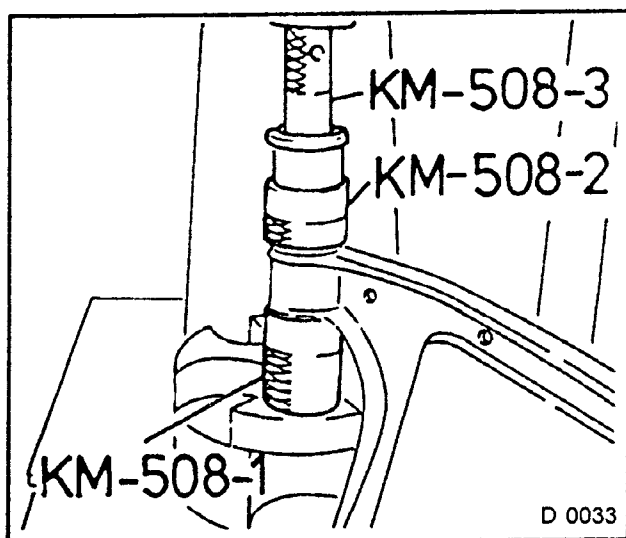


Fig 64

**ASSEMBLE**

1. New rear damping bushings.  
Press in with KM-613-1 and KM-613-2 from below, control arm in installation position.

**INSTALL, CONNECT**

1. Control arm — (see page 29).

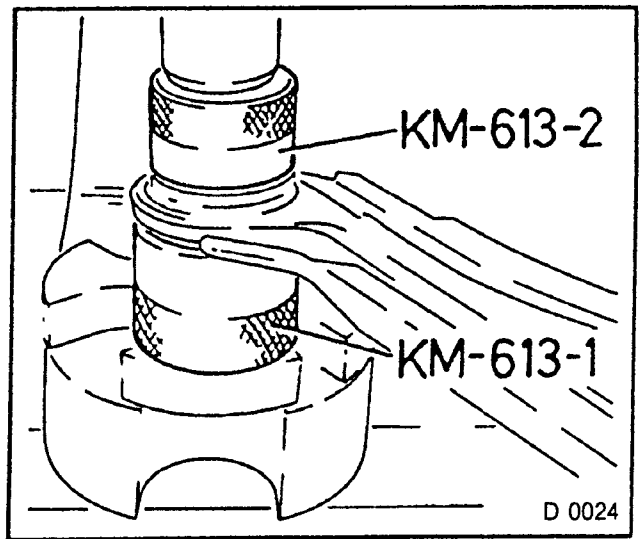


Fig. 65

**Ball Joint on Control Arm — Remove and Install****REMOVE, DISCONNECT**

1. Control arm (see page 29).

**DISASSEMBLE**

1. Ball joint rivet heads.  
Drill off with 12 mm drill.  
Place drill on side of rivet head with centre mark

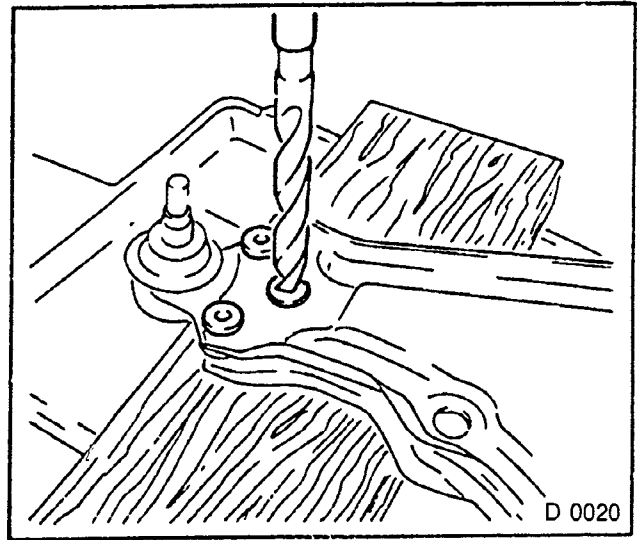


Fig. 66

**TIGHTEN (Torque)**

1. Ball joint to control arm — 60 Nm.  
Ball joint is replaced as assembly only  
Special bolts and nuts see Parts  
Catalogue.  
Screw on nuts of control arm underside.

**INSTALL, CONNECT**

1. Control arm (see page 29).

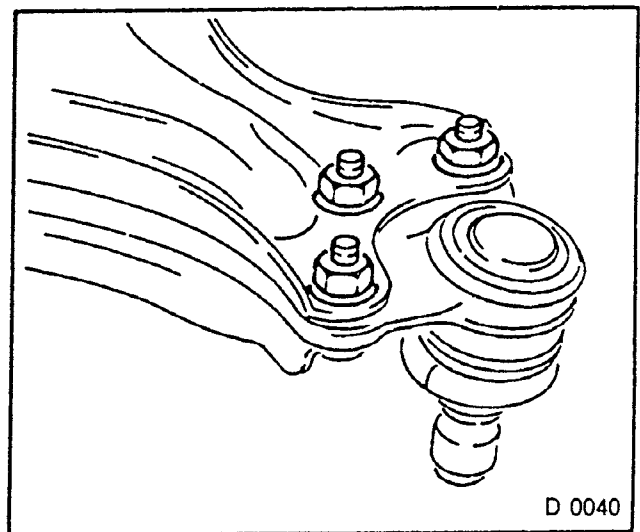


Fig. 67

## Front Axle Body — Remove and Install

### REMOVE, DISCONNECT

1. Disconnect battery.
2. Oxygen sensor wiring harness plug (DOHC engines only)
3. Jack up engine with Engine Lifter KM-263-A and two guiding hooks.
4. Both front wheels, engine compartment covering.
5. Front exhaust pipe.
6. On DOHC engine separate at joint only.

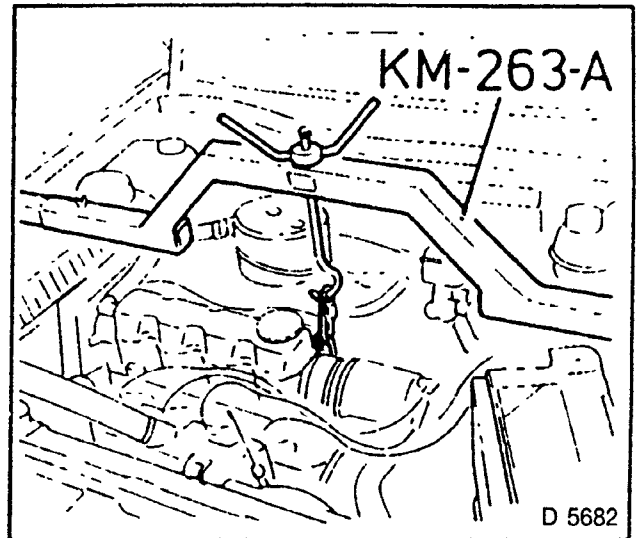


Fig 68

### REMOVE, DISCONNECT

1. Both ball joints from steering knuckle. KM-507-C.
2. Rear transmission bracket.
3. Front axle body.
4. Support with hydraulic jack and unscrew fastening bolts — high torque.
5. Lower front axle body and remove. (Fig. 69 shows front axle body with long outrigger)

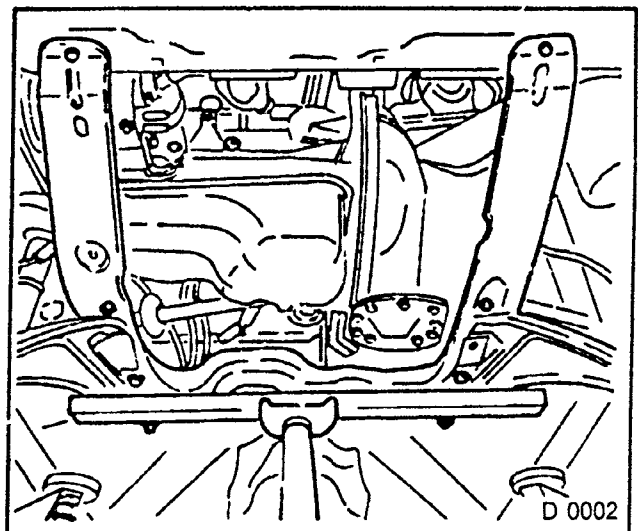


Fig. 69

## Front Axle Body — Transfer

1. If front axle body is replaced, tension it in vice.
2. Remove stabilizer and both traverse control arms.
3. Mounting sleeves in rear damping bushing are not applicable when installing. (Fig. 70 shows front axle body with long outrigger).

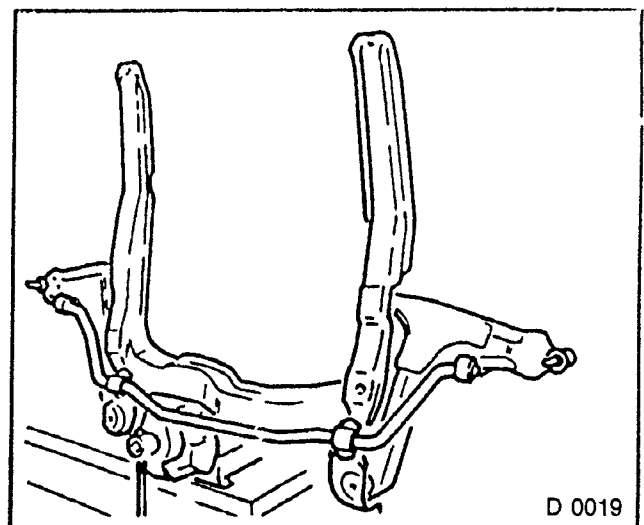


Fig 70

**TIGHTEN (Torque)**

1. Control arm to front axle body — 110 Nm + 60° to 75°.
2. Control arm in horizontal position.
3. Stabilizer to front axle body — 20 Nm.

**INSTALL, CONNECT**

1. Stabilizer to control arm.
2. Maintain pre-tension dimension "1" = 38 — 39 mm.  
If necessary, replace rubber buffer.
3. Use new Nuts, counterhold with Self-locking Nuts — 20 Nm.

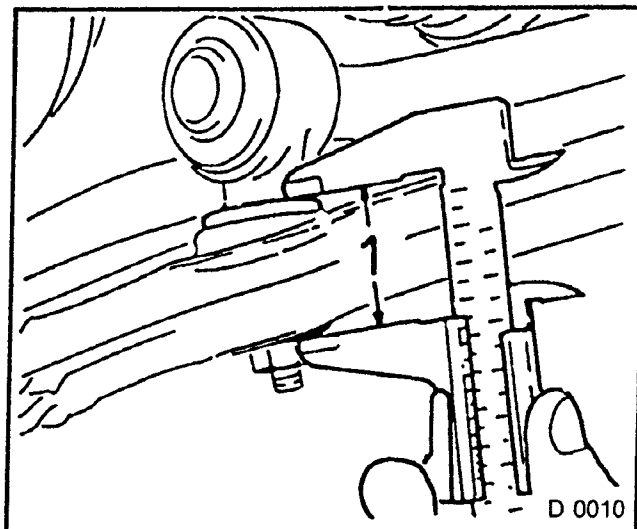


Fig. 71

**INSTALL, CONNECT**

1. Cut thread for front axle bolts.  
M12 x 1,5  
M14 x 1,5
2. Front axle body.
3. Raise with hydraulic jack.
4. Insert ball joints in steering knuckle and transmission bracket in front axle body.

**TIGHTEN (Torque)**

Front axle body to underbody.

1. Bolts (1) — 115 Nm.
2. Bolts (2) — 170 Nm.

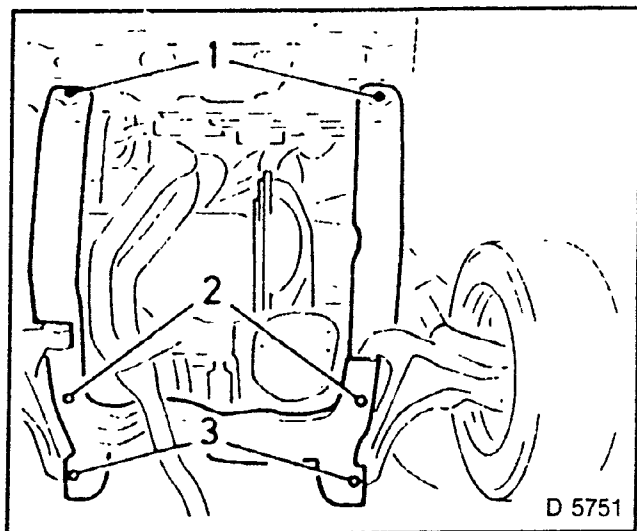


Fig. 72

**TORQUE — ANGLE METHOD**

Bolts (3 in Fig. 72) — 100 Nm + 75° to 90°.

**TIGHTEN (Torque)**

1. Transmission bracket on front axle body (arrows) — 40 Nm.
2. Ball joint to steering knuckle — 70 Nm.
3. Use new retaining clamp and new nuts.

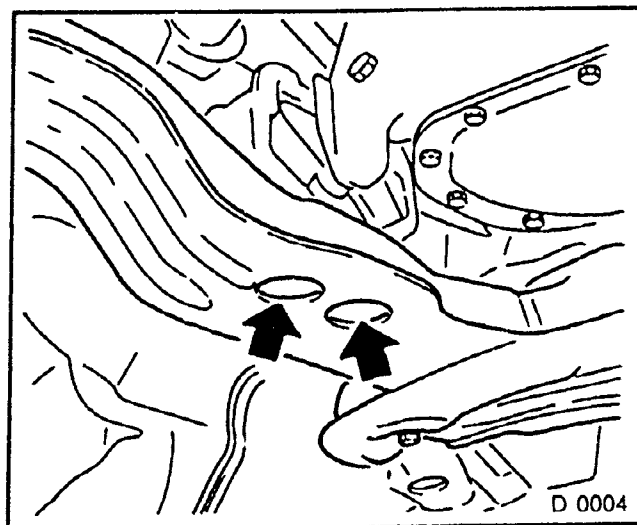


Fig. 73

**INSTALL, CONNECT**

1. Front exhaust pipe or joint piece.
2. Engine compartment cover.
3. Front wheels.
4. Oxygen sensor wiring harness plug (arrow) (DOHC engines only).

**REMOVE, DISCONNECT**

1. Engine Lifter — KM-263-A.

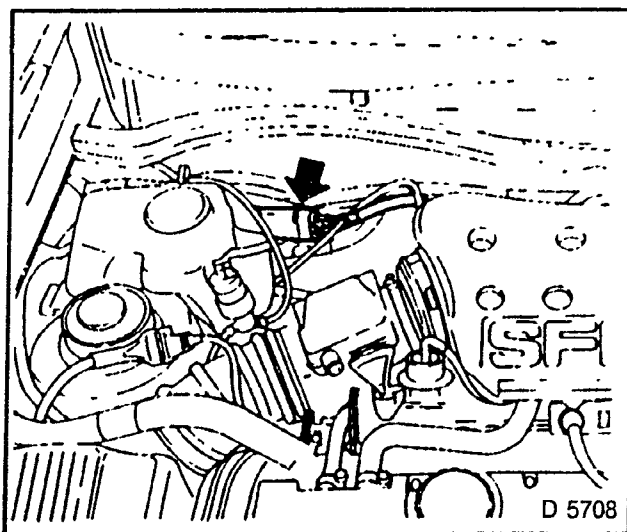


Fig. 74



## Stabilizer — Remove and Install

### INSTALL, CONNECT

1. Engine Lifter — KM-263-A.

### REMOVE, DISCONNECT

1. Stabilizer fastening from control arm.
2. Bracket for transmission from front axle body.

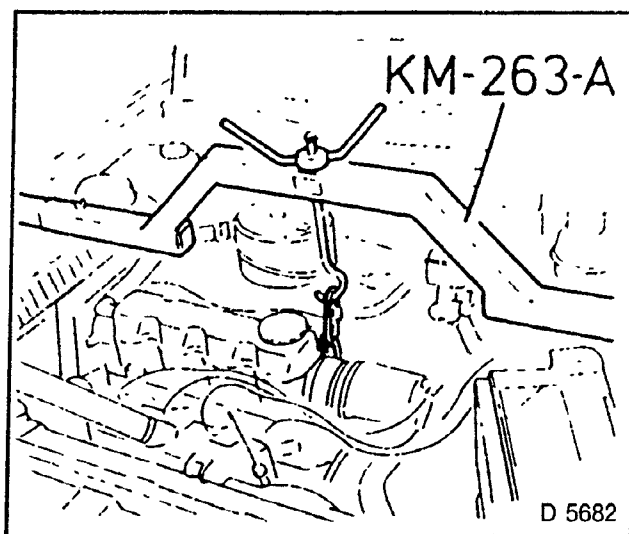


Fig 75

### REMOVE, DISCONNECT

1. Lower front axle body.
2. Support with hydraulic jack.
3. Unscrew rear fastening bolts, only loosen front bolts.
4. Lower front axle body, until fastening bolts for stabilizer (arrows) are accessible.
5. Stabilizer.

If stabilizer is replaced, transfer damping weight —

Note installation position.

If necessary, replace pendulum — (see "Pendulum, Remove and Install", page 37).

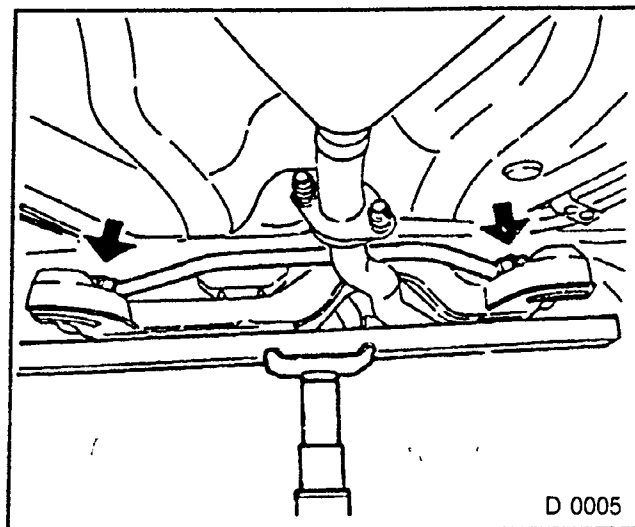


Fig 76

### INSTALL, CONNECT

1. Stabilizer to front axle body — 20 Nm.
2. Secure stabilizer with lock nut M8 — 20 Nm.
3. Front axle body to underbody (see Front Axle Body, Remove and Install, page 33).
4. Pendulum to control arm — (see Pendulum, Remove and Install, page 37).

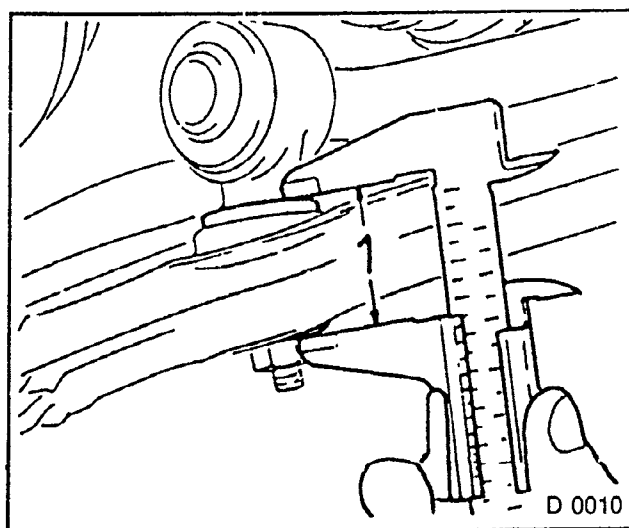


Fig 77

## Pendulum — Remove and Install

### REMOVE, DISCONNECT

1. Front wheel.
2. Stabilizer fastening from control arm.
3. Ball joint from steering knuckle, KM-507-C.
4. Spray oil between pendulum and stabilizer.
5. Pendulum from stabilizer — KM-507-C.
6. If necessary, in repeated operations, suitable spacers between KM-507-C and stabilizer (arrow).

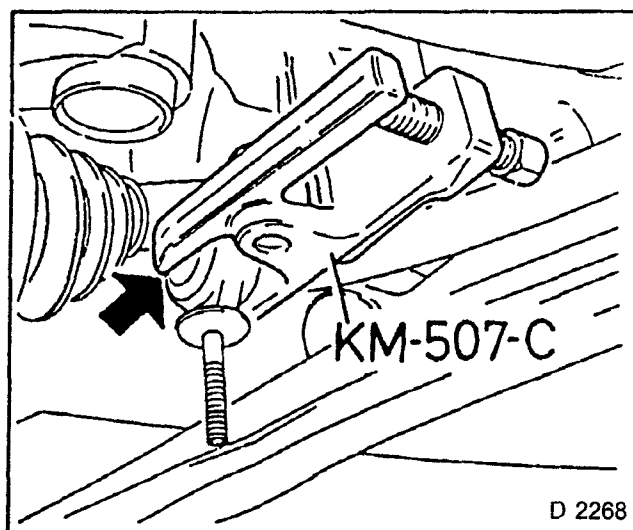


Fig. 78

### INSTALL, CONNECT

1. Clean stabilizer.
2. Pendulum on stabilizer — if necessary, coat with liquid soap solution. See fig. 79 for installation position.
3. Ball joint to steering knuckle — 70 Nm (new retaining clamp.)
4. Pendulum to control arm — if necessary, replace rubber buffer.
5. Maintain pre-tension dimension "1" = 38 — 39 mm. Use new Nuts, counterhold with self-locking Nuts — 20 Nm.
6. Front wheel — 110 Nm.

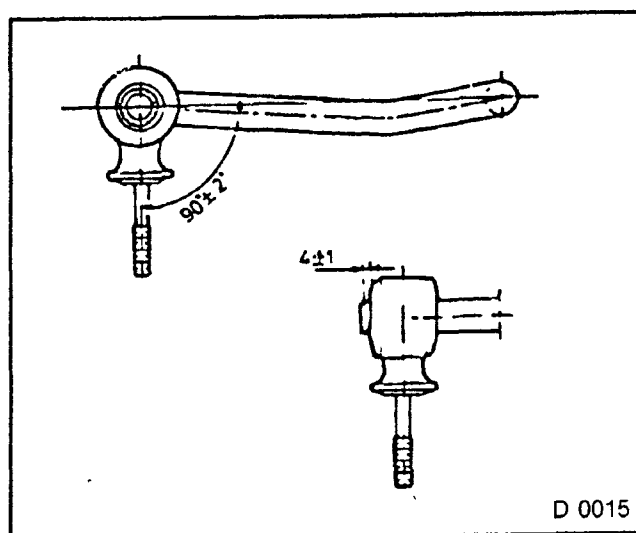


Fig. 79

## Wheels and Tyres

All ASTRA-F models are fitted ex works with tubeless steel-belted radial tyres.

Breakdown of Tyre Designation:

Example: 175/65 R14 — 82T

175 = Tyre width (in mm)

65 = Tyre height (in % of tyre width)

R = Radial design

14 = Rim diameter (in inches)

82 = Carrying load — identification number

T = Speed classification

Only disc wheels with safety rims — so-called hump rims — may be used in conjunction with tubeless tyres. The hump is a ring-shaped bead on the shoulder of the rim, which prevents the tyre from slipping into the wheel rim.

With asymmetric deep well rims, the tyre must be mounted across the narrow shoulder of the disc wheel, i.e. from the outside of the wheel.

The disc wheels are centred on the wheel hubs by means of the centre hole. To prevent rusting, the centring seat of the disc wheel is to be lightly coated with Bearing Grease 19 41 574 (90 001 812) before each mounting.

The tyre pressures can be found on page 41 and in the Owner's and Driver's Manual.

## Wheel Balancing

To balance the wheels properly, commence with “stationary” balancing. If necessary, eliminate any remaining imbalance on the vehicle with a mobile “precision balancer”.

Manufacturers’ instructions are to be carried out when using the balancing equipment.

### **Balancing on wheel balancer (stationary)**

Special balancing equipment is used to equalise the imbalance present in the vehicle wheels as far as possible. Stationary wheel balancers for precise balancing and in particular static (vertical) and dynamic (horizontal) balancing are well-known. However, these machines can measure only imbalances caused by the disc wheel and the tyre (wheel assembly).

To maintain a minimum of vehicle imbalance, wheel balancing should be carried out as accurately as possible. The disc wheels of the ASTRA-F are centred at the hub.

Residual imbalances may appear after the wheel has been installed. These are mostly caused by co-rotating parts such as hub, brake drum or brake disc.

### **Balancing with precision balancing equipment (on vehicle)**

To equalise any remaining imbalance which may be present, the wheels on the vehicle can be subsequently balanced with mobile balancers (finish balancer or precision balancing equipment). Raise the vehicle to equalize imbalance.

## Front and Rear Wheels — Electronically Balance

Electronic balancing is carried out with a mobile balancer in conjunction with one or two measuring units (sensor stands) with built-in force sensors.

### CAUTION:

The rotation of the wheels (in direction of travel) can be carried out with a friction wheel.

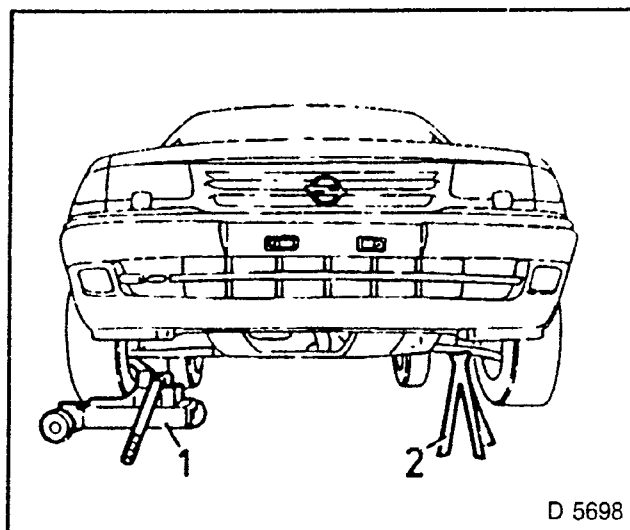
On manual transmission shift lever in neutral position.

The speed must not exceed 150 km/h when balancing with precision balancer.

If the drive wheels have different directions of rotation or running speeds, the measuring process can possibly be interrupted when using precision balancing equipment with infrared sensing and selective measuring operation.

Rotation of the wheels can be produced by the vehicle's own engine. An exhaust suction system must be present in the service area.

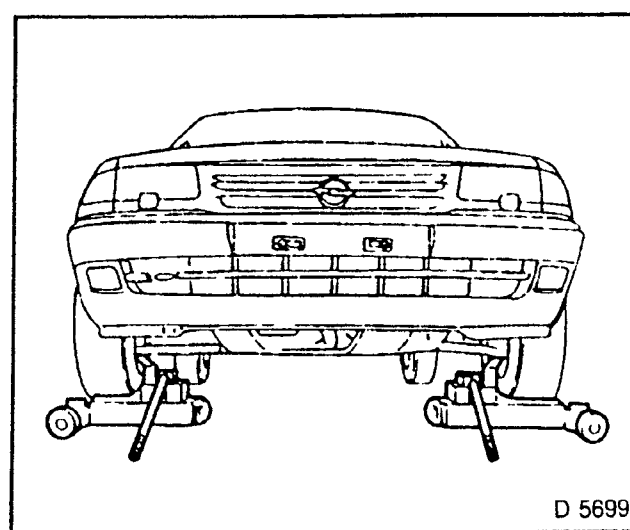
When using a sensor stand (1) on the front axle, place under the vehicle first, and the opposite side then supported with a floor stand (2).



D 5698

Fig 80

There is an advantage in using two sensor stands. The first wheel balanced can be re-checked without repositioning the sensor stand or the floor stand to determine any influence exerted by the opposite wheel as it rotates with it.



D 5699

Fig. 81

Support on the control arm below the ball joint rivetted joint.

Use a suitable sensor stand adapter from the manufacturer of the balancing equipment being used.

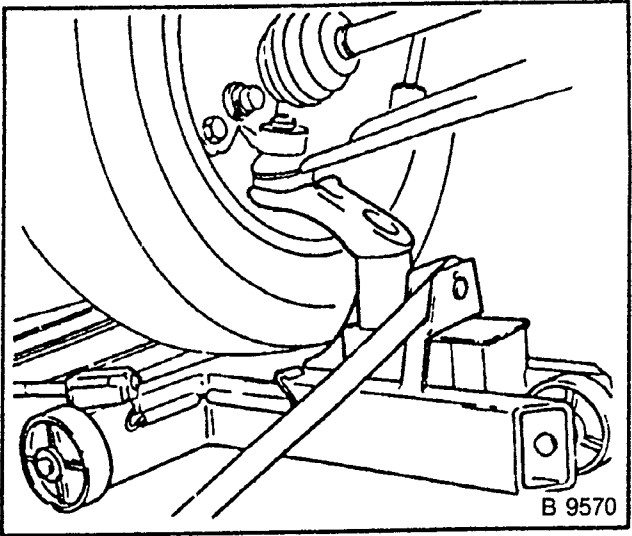


Fig 82

“Stationary balancing” of the rear wheels is generally sufficient. Should it be necessary to re-balance the vehicle, one is to proceed with the use of sensor stands as with the front axle.

The vehicle is supported on the lower shock absorber fastening.

When doing this, it is permissible that when using a sensor stand, the opposite side is not lifted.

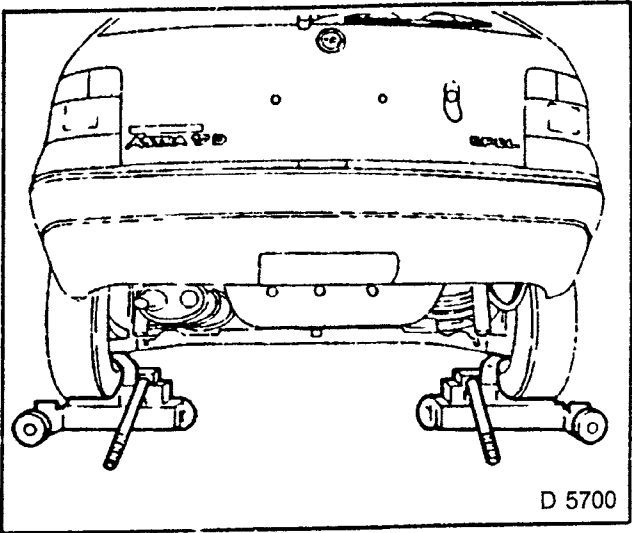


Fig 83

## Tyre Sizes and Pressures

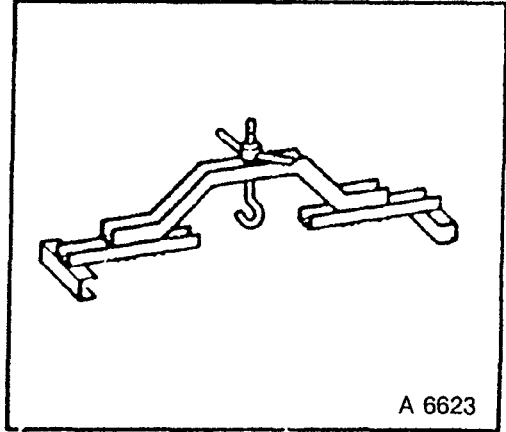
MODEL	DESIG-NATION	RIM SIZE	TYRE TYPE	TYRE SIZE	TYRE REVS/KM	kPa	
						TYRE PRESSURE FRT/RR (UNLADEN)	TYRE PRESSURE FRT/RR (LADEN)
ASTRA	140	5J x 13	STEELBELT	155 SR 13	567	200/180	210/230
	160i S	5.5J x 14	STEELBELT	175/65 TR 14	561	210/190	220/240
	160i	5J x 13	STEELBELT	165 SR 13	550	200/180	210/230
	160i E	5.5J x 14	STEELBELT	175/65 TR 14	561	210/190	220/240
	180i	5.5J x 14	STEELBELT	185/65 HR 14	550	210/190	220/240
	180i AT	5.5J x 14	STEELBELT	185/65 HR 14	550	210/190	220/240
	200i	5.5J x 14	STEELBELT	185/65 HR 14	550	210/190	220/240
	200i E	5.5J x 14	STEELBELT	195/60 VR 14	556	210/190	220/240
KADETT	140	5J x 13	STEELBELT	155 SR 13	567	200/180	210/230
	140 S	5J x 13	STEELBELT	165 SR 13	550	200/180	210/230
	160i	5J x 13	STEELBELT	165 SR 13	550	200/180	210/230
	200i S	6J x 15	STEELBELT	195/50 HR 15	569	230/210	240/250
	200i S	6J x 16	STEELBELT	205/45 ZR 16	555	220/220	250/260

Pressure values refer to cold tyres. The pressure increase of 0.2 to 0.4 bar occurring after extended driving must not be reduced.

## Special Service Tools

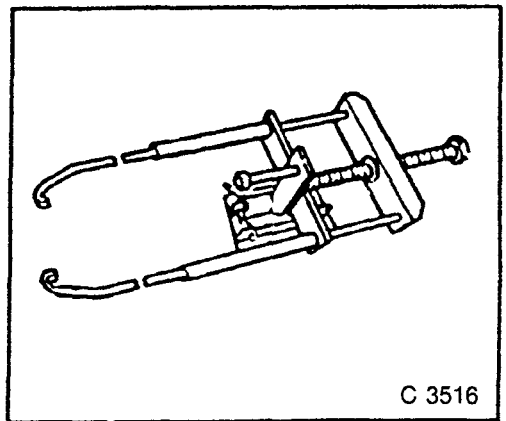
### KM-263 Engine Lifter/Holder

To hold engine with Engine Lifter on clip with two commercially available guiding hooks.



### KM-329-A Front Spring Compressor

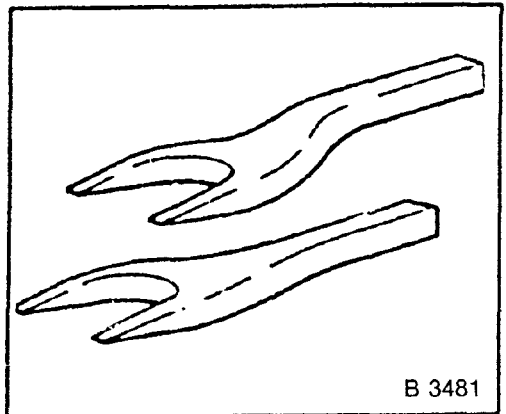
To tension front spring with spring strut removed.



### KM-460-A Removing Forks

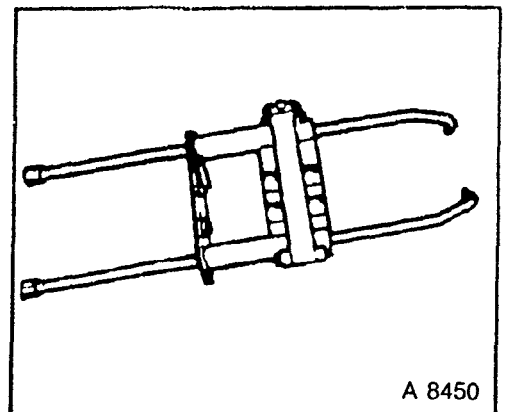
To remove axle driving shafts from transmission housing (F10, F13 manual transmission).

To remove right drive shaft from transmission housing (F16).



### KM-465-A Front Spring Compressor

To tension front spring together with KM-329-A

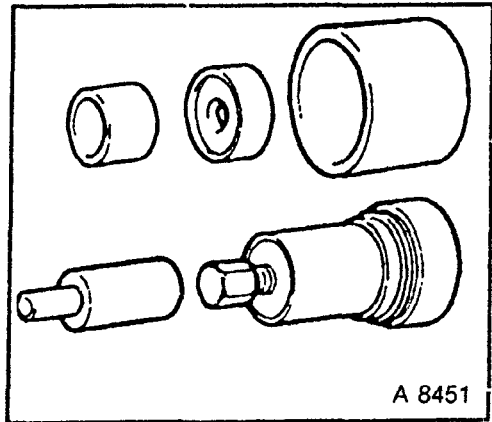


**KM-466-A Remover/Installer**

To remove and install wheel bearing (F10, F13 manual transmission).

**IMPORTANT**

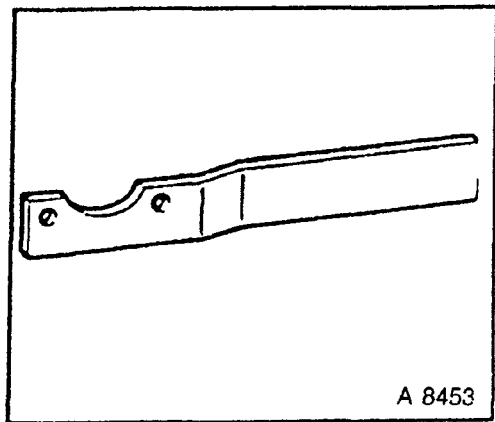
Shorten Remover KM-466-4 by 1 mm by plane grinding on the bearing sided heel. New KM-466-4-A tools have been changed accordingly.



A 8451

**KM-468 Holding Wrench**

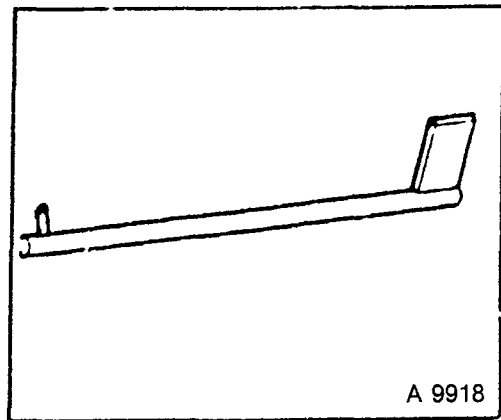
To counterhold when tightening wheel bolts to hub.



A 8453

**KM-476 Measuring Device**

To check straight ahead drive position.



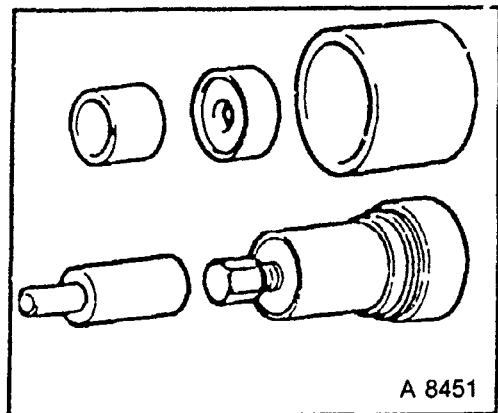
A 9918

**KM-500-A Remover/Installer**

To remove and install wheel bearing.

**IMPORTANT**

Shorten Remover KM-500-4 by 1 mm by plane grinding on the bearing sided heel. New KM-500-4-A tools have been changed accordingly.

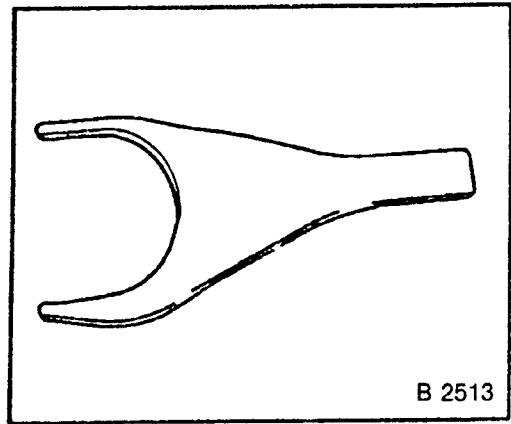


A 8451



**KM-503-A Removing Forks**

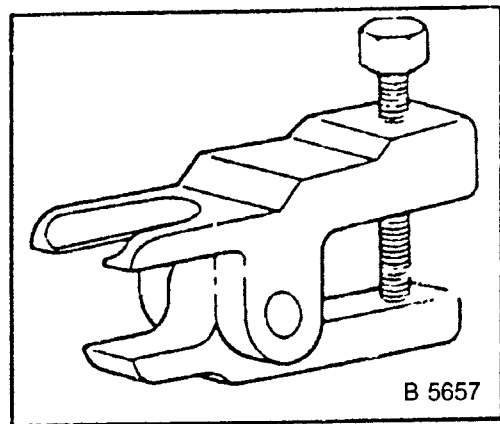
To remove left axle driving shaft from the transmission housing (F16, F20 manual transmission).



B 2513

**KM-507-C Remover**

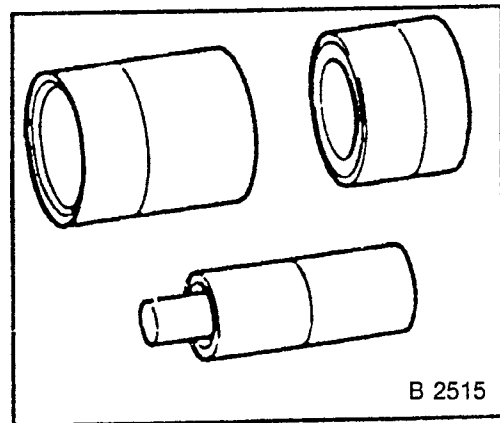
To press out ball joint and tie rod joint.



B 5657

**KM-508-A Remover/Installer**

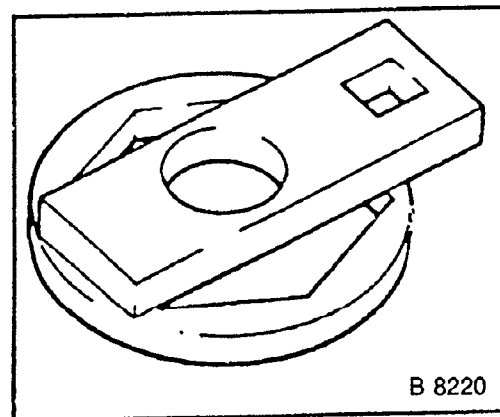
To remove and install front damping bushing in control arm



B 2515

**KM-563 Wrench (replacement for KM-331)**

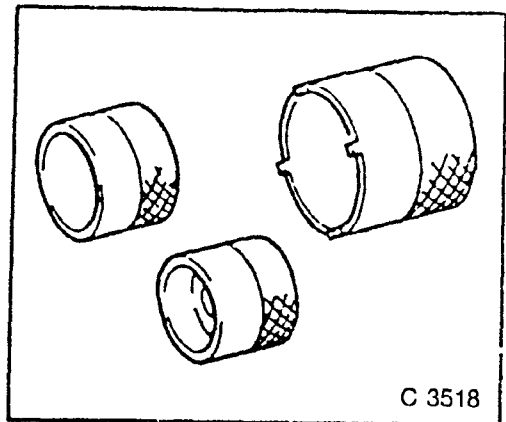
To unscrew and screw on threaded ring (plate nut) from/onto carrier tube.



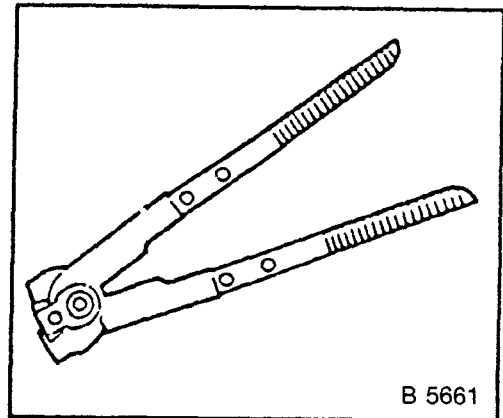
B 8220

**KM-613-A Remover/Installer**

To remove and install rear damping bushing in control arm.

**KM-J-22610 Pliers**

To tension folding cover retaining strap of axle driving shaft.

**38-A Kukko Hub Remover**

To remove axle driving shaft from front wheel hub. See supplier.

## Front Wheel Adjustment

The tyre pressure is to be taken from the tyre pressure table on page 41.

Laden: The given values are valid for a vehicle with each front seat laden with 70 kg. Fuel tank approximately half full.

Camber laden:  $-1^{\circ} 05' \pm 45'$   
(not adjustable) Deviation from left to right wheel:  $1^{\circ}$  max.

Caster laden:  $+2^{\circ} 15' \pm 1^{\circ}$   
Deviation from left to right wheel:  $1^{\circ}$  max.

Toe-out (refers to both wheels without thrust rod)

Laden:  $0^{\circ} 15' \pm 10'$   
2,5 mm toe-out to 0,5 mm toe-out  
When re-adjusting, as close as possible to average value.

Toe-in variation (with inner wheel angle at  $20^{\circ}$ ; toe-in = 0)

Laden:  $1^{\circ} 25' \pm 45'$   
Deviation from left to right wheel:  $40'$  max.

## Radial/Lateral Runout

### Steel disc wheel:

Wheel offset (mm)	Max. permissible runout (mm)	
	radial	lateral
$49 \pm 1$	0,8	1,0

### Light alloy disc wheel:

Wheel offset	Max permissible runout (mm)	
	radial	lateral
$49 \pm 1$	0,25	0,3

The maximum permissible radial runout is measured at the rim shoulder, and the maximum permissible lateral runout is measured at the side surface of the rim flange.

## Recommended Torque Values

	Nm
ABS SENSOR BRACKET TO STEERING KNUCKLE .....	8
BALL JOINT TO CONTROL ARM .....	60
BALL JOINT TO STEERING KNUCKLE .....	70
BRAKE CALIPER BRACKET TO STEERING KNUCKLE .....	95
BRAKE CALIPER TO STEERING KNUCKLE .....	95
BRAKE DISC TO FRONT WHEEL HUB .....	4
COVER PLATE TO STEERING KNUCKLE ..	4
DAMPING WEIGHT TO CONTROL ARM .....	20
FRONT AXLE BODY TO FLOOR CROSSMEMBER (3) .....	*1)
FRONT AXLE BODY TO RADIATOR CROSSMEMBER (1) .....	115 <sup>1)</sup>
FRONT AXLE BODY WITH CONTROL ARM TO SUPPORT (2) .....	170 <sup>1)</sup>
FRONT CONTROL ARM TO FRONT AXLE BODY ..	**
LOCK NUT TO STABILIZER .....	20
PISTON ROD TO SUPPORT BEARING .....	55
REAR CONTROL ARM WITH FRONT AXLE BODY TO SUPPORT .....	170
SPRING STRUT TO WHEEL WELL ..	30
STABILIZER TO CONTROL ARM .....	20 <sup>2)</sup>
STABILIZER TO FRONT AXLE BODY .....	20
SUPPORT BEARING TO PISTON ROD .....	55
THREADED RING FOR SPRING STRUT CARTRIDGE TO SUPPORT TUBE ..	200
TIE ROD CLAMP CONNECTION .....	20
TIE ROD JOINT TO TIE ROD LEVER .....	60
TRANSMISSION BRACKET TO FRONT AXLE BODY .....	40
VIBRATION DAMPER TO AXLE SHAFT .....	10
WHEEL BOLTS .....	110

\* Must be tightened in two stages: 100 Nm + 75° to 90°

\*\* Must be tightened in two stages: 100 Nm + 60° to 75°

1) Use new bolts

2) Use new nuts maintain pretension dimension of 38 — 39 mm.

**Opel Astra**  **Opel Kadett**

## **Workshop Manual**

### **Section F**

# **Rear Axle and Rear Wheel Suspension**

Issued by: Service Division  
Delta Motor Corporation  
July, 1993

# Index

*Page*

## General Information

ILLUSTRATIONS..... F- 2

## Checking and Adjusting Operations

REAR AXLE ALIGNMENT..... F- 5

## Tilt Play at Wheel Bearing

WHEEL BEARING UNIT WITH DISC BRAKE ..... F- 6

WHEEL BEARING UNIT WITH DRUM BRAKE . . . . . F- 7

RADIAL AND LATERAL RUNOUT, MEASURE ... . . . . F- 7

## Rear Axle — Damping Bushings

REAR AXLE DAMPING BUSHINGS, REPLACE..... F-12

REAR AXLE, REMOVE AND INSTALL..... F- 9

REAR AXLE, MODIFY ..... F- 9

## Rear Springs

REAR SPRINGS AND/OR DAMPING RINGS OF REAR SPRINGS, REMOVE AND INSTALL... . . . . F-14

## Wheel Bearing Unit

REAR WHEEL HUB (DISC HUB) REPLACE ONE.. . . . F-15

WHEEL SPINDLE, REMOVE AND INSTALL OR REPLACE .. . . . F-19

WHEEL BEARINGS OF REAR WHEEL HUB (DISC HUB) REPLACE BOTH . . . . . F-19

SEAL RING OF ONE REAR WHEEL HUB (DISC HUB) REPLACE . . . . . F-21

## Stabilizer, Shock Absorbers

STABILIZER, REMOVE AND INSTALL..... F-24

SHOCK ABSORBER AND/OR RUBBER BUFFER OF SHOCK ABSORBER, REMOVE AND INSTALL ... .. F-23

ADDITIONAL STABILIZER, REMOVE AND INSTALL..... F-24

## Special Service Tools.....

F-25

## Technical Data.....

F-27

## RECOMMENDED TORQUE VALUES.....

F-28

## GENERAL INFORMATION

When removing the wheels from the vehicle, mark the position in line with the wheel bearing unit. These marks should be noted when reattaching the wheel.

Always tighten the wheel bolts with a torque of 110 Nm.

For bolt connections which are inserted with locking compound, the threads must be cleaned with the appropriate screw tap.

If the new bolts are not microencapsulated, they should be installed with Sealing Compound.

Clean the threads of microencapsulated bolts which are used again.

When installing, ensure that no dirt gets between the brake disc and the wheel hub. The contact surfaces must be plane and without weals.

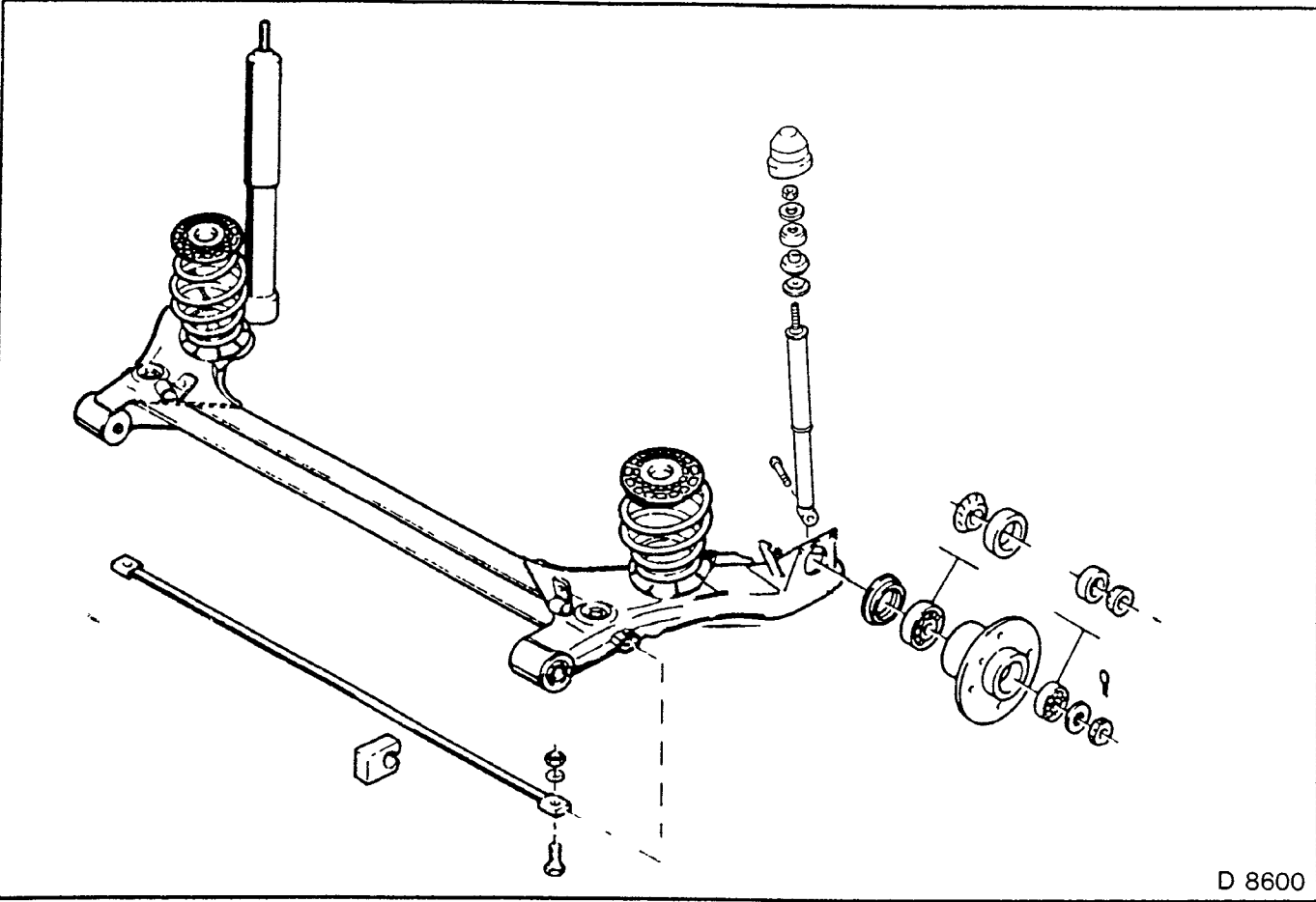
Always use new nuts when installing wheel bearing unit. Contact surfaces and threads in the wheel bearing unit must be free of grease, paint and dirt.

Always replace damping bushings, damper rings, shockabsorbers, rear springs and brake discs in pairs.

If an operation is described referring only to one side of the rear axle, the directions apply equally to the other side.

All operations must be carried out at the technician's own responsibility according to the regulations of the local authorities regarding health protection, accident prevention and environmental protection.

Rear Axle with Drum Brake



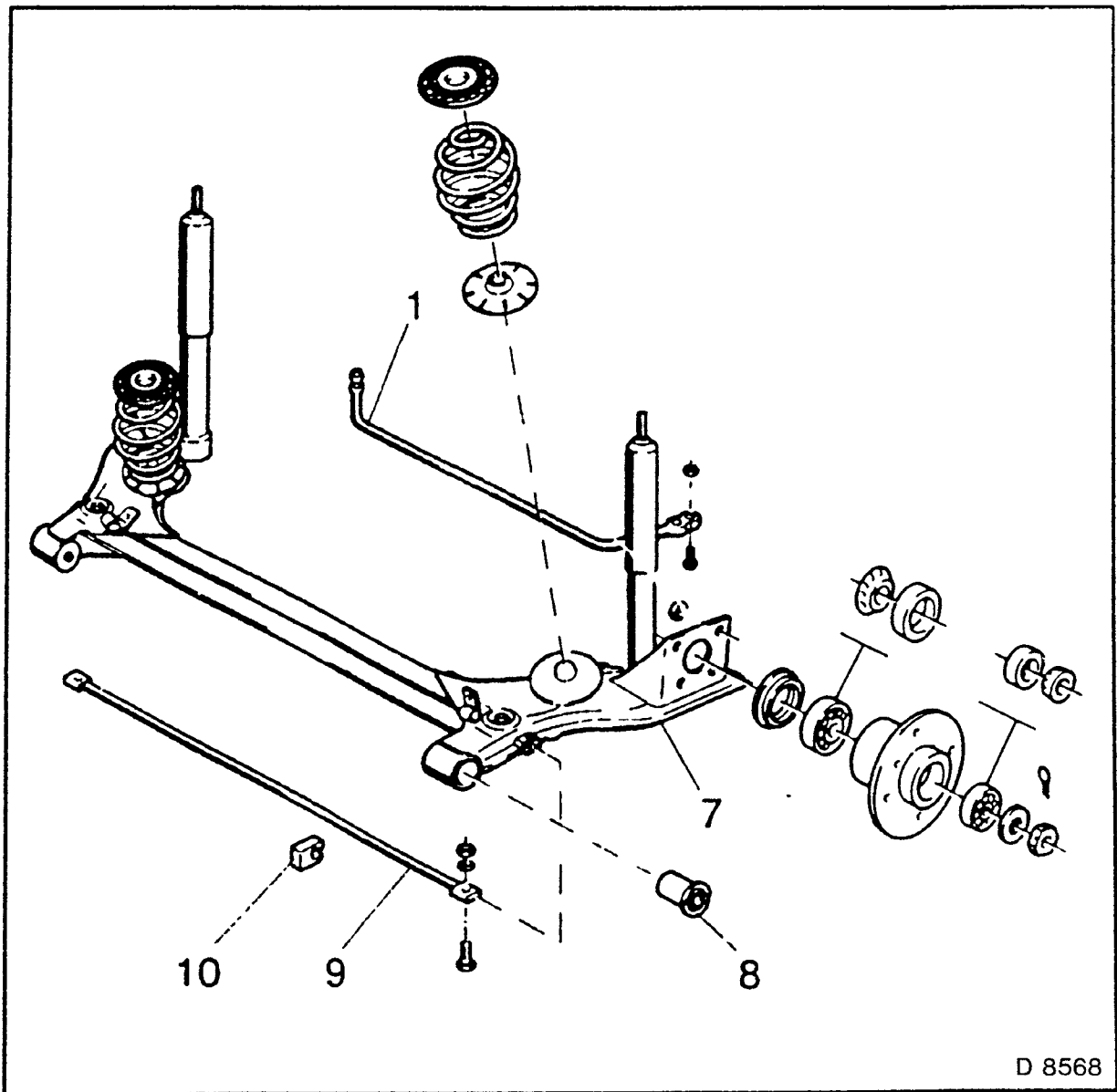
D 8600

Fig. 1



## REAR AXLE — WITH DISC BRAKE

- 1 — Additional stabilizer
- 2 — Wheel bearing unit without ABS
- 3 — Wheel bearing unit with ABS
- 4 — Brake backing plate
- 5 — Brake disc
- 6 — Detent screw
- 7 — Rear axle body
- 8 — Damping bushing
- 9 — Stabilizer
- 10 — Damping block



D 8568

Fig. 2

## CHECKING AND ADJUSTING OPERATIONS

### Rear Axle Alignment

### Camber and Toe-in, Check

#### IMPORTANT

1. Tread on all tyres uniform and in good condition.
2. Tyre pressures must be equal on both sides of the axle — see section E and Owner's and Driver's Manual.
3. The rim flange of each disc wheel to be checked must be in satisfactory condition.
4. Prepare vehicle for measurement.

Load each of the front seats with 70 kg

Ensure fuel tank is half full.

Stabilise the springs by rocking the vehicle several times.

If this measure is omitted, the camber angle measured will be too great, as the semi-trailing arm will not have resumed its normal position.

When using axle alignment turntables which cannot record lateral forces, the vehicle must initially be rolled back about 1 m and then pushed forward again

Establish "actual value" using optical alignment tester, see "Technical Data" page 27.

Please note manufacturer's instructions and specifications.

Complete alignment measurement card

## TILT PLAY AT WHEEL BEARING

### Wheel Bearing Unit with Disc Brake

In case of noticeable play at mounted wheel, carry out measurement as follows:

1. Remove rear wheels, clean affected surfaces.
2. KM-468 (1) to wheel bearing unit.
3. Attach Dial Gauge MKM—571—B (2) with dial indicator and magnetic base (3) to brake caliper.
4. Place probe of dial gauge at outer edge of wheel hub (arrow).
5. Check play by levering slightly with KM—468.
6. Counterhold brake disc with hand, to avoid twisting.  
Permissible play: max. 0.3 mm.  
If the permissible play is exceeded, replace the wheel bearing unit — see operation “Wheel Bearing, Remove and Install” page 19.

## Wheel Bearing Unit with Drum Brake

In case of noticeable play at mounted wheel, carry out measurement as follows:

1. Remove rear wheels and brake drums, clean wheel hubs thoroughly.
2. Rear Wheel Bearing KM—468 to wheel bearing unit.
3. Fasten Dial Gauge MKM—571—B with Dial Indicator MKM—572 to brake anchor plate.
4. Place probe of dial gauge at outer edge of wheel hub (arrow)

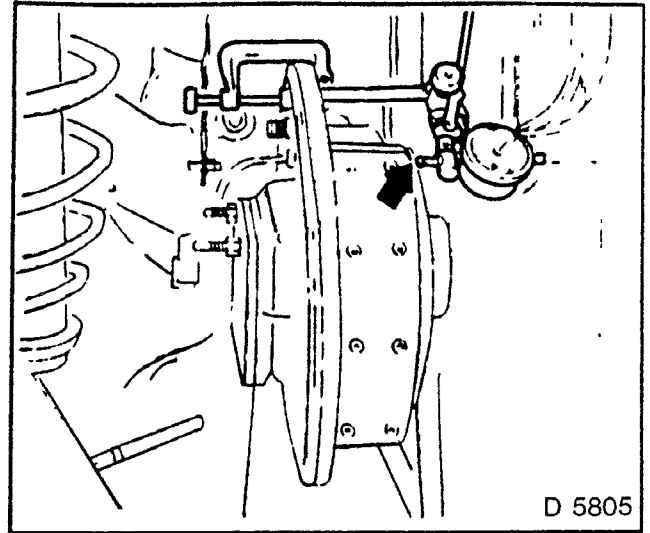


Fig. 4

5. Check play by levering slightly with KM—468.
6. Counterhold wheel hub with hand, to avoid twisting.  
Permissible play: max. 0.3 mm.  
If the permissible play is exceeded, replace the wheel bearing unit — see operation “Wheel Bearing, Remove and Install” page 19.

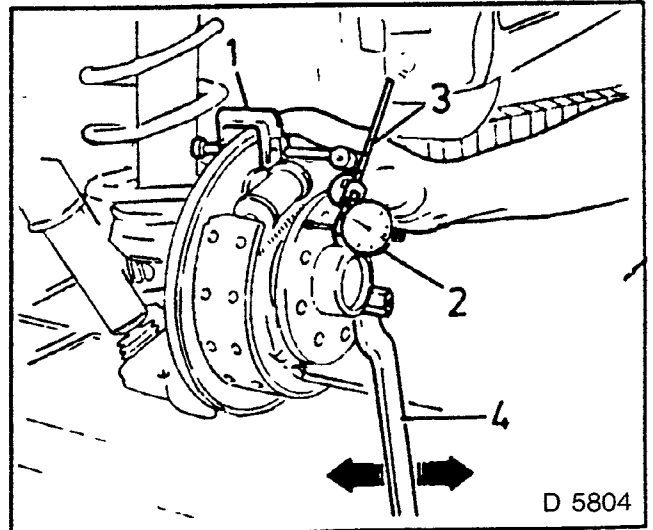


Fig 5

## Radial and Lateral Runout, Measure

### REMOVE, DISCONNECT

1. Brake drum or brake caliper and brake disc.

### CLEAN

Clean surfaces affected by the measurement.

1. Fasten Dial Gauge (3) with Dial Indicator MKM—572 (1) to brake anchor plate.
2. Place probe of dial gauge (2) to plane surface.
3. Turn wheel hub slowly.  
Permissible lateral run-out max. 0,05 mm.

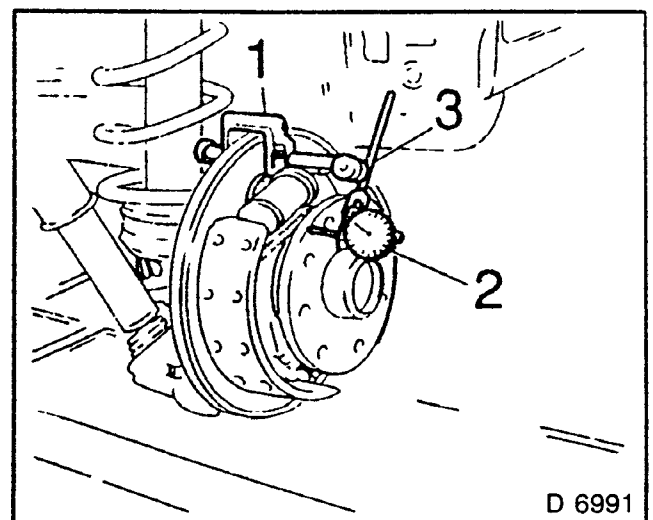


Fig. 6

Proceed similarly for radial run-out.

1. Place probe at outer circumference of wheel hub.
2. Turn hub slowly.  
Permissible radial run-out max. 0,05 mm.

For vehicles with disc brakes, use magnetic base instead of vice. To do so, screw on brake caliper again if necessary, to fasten the magnetic base to it.

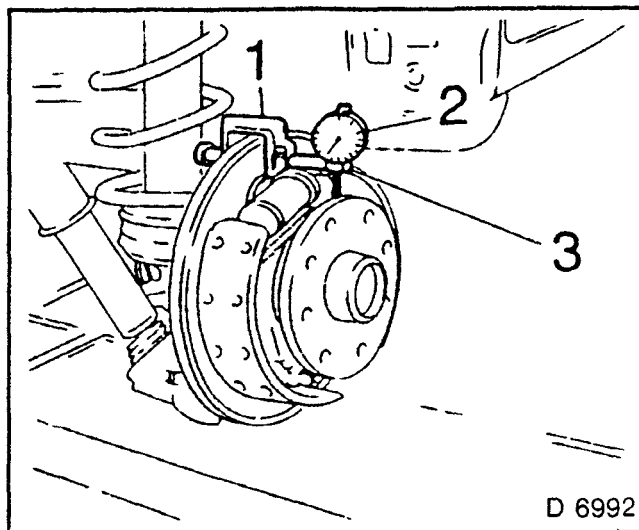


Fig. 7

## REAR AXLE — DAMPING BUSHINGS

### Rear Axle, Remove and Install

Close break fluid reservoir with blind screw cap.

#### REMOVE, DISCONNECT

1. Rear wheels.
2. Release air from filler valve on car level control.
3. Loosen brake cable compensating yoke — measure length of threads.
4. Parking brake cable from tie rod (1)

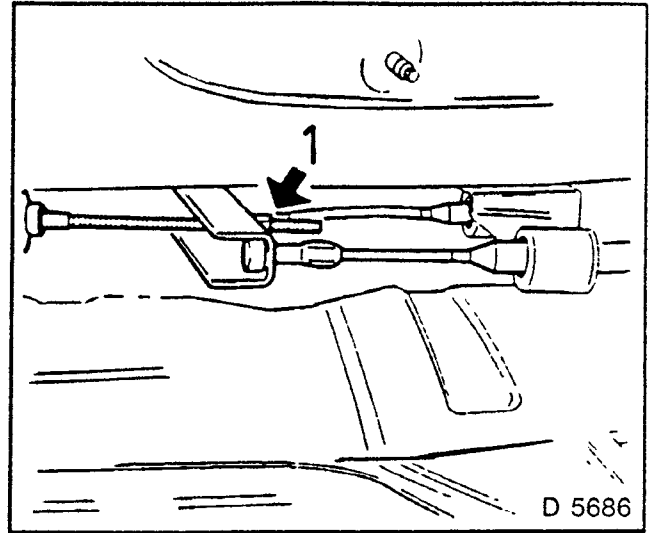


Fig. 8

#### REMOVE, DISCONNECT

1. Parking brake cable from retainer on vehicle underbody
2. Brake lines from brake pressure hoses
3. Close openings.
4. Wiring harness plug for ABS sensor from wheel bearing unit.
5. ABS cable from retainers.
6. Place hydraulic jack centrally under rear axle.
7. Loosen bolts for rear axle bearing and lever out.
8. Shock absorbers from outrigger —support outrigger.
9. Lower hydraulic jack until springs with damping rings can be removed from rear axle.
10. Lower rear axle.

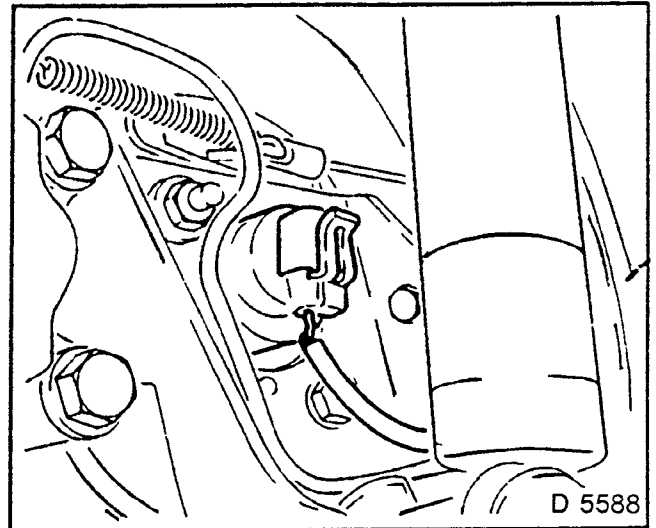


Fig 9

### Rear Axle, Modify

Clamp rear axle in vice with protective jaws.

#### DISASSEMBLE

1. Brake disc from wheel bearing unit — disc brake.  
Brake drum from wheel bearing housing — drum brake.
2. If necessary, press back parking brake shoe lever.
3. Brake cable — detach from cable guide.

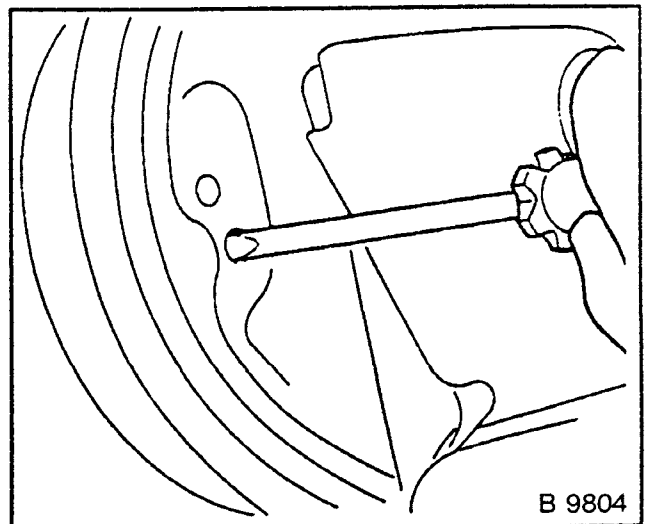


Fig. 10

**DISASSEMBLE**

1. Wheel bearing unit with brake backing plate/brake anchor plate.  
Drum brake. brake lines from retainer
2. Stabilizer and additional stabilizer, where fitted, from rear axle.

**INSPECT**

1. Brake shoes, brake linings — see Section H.

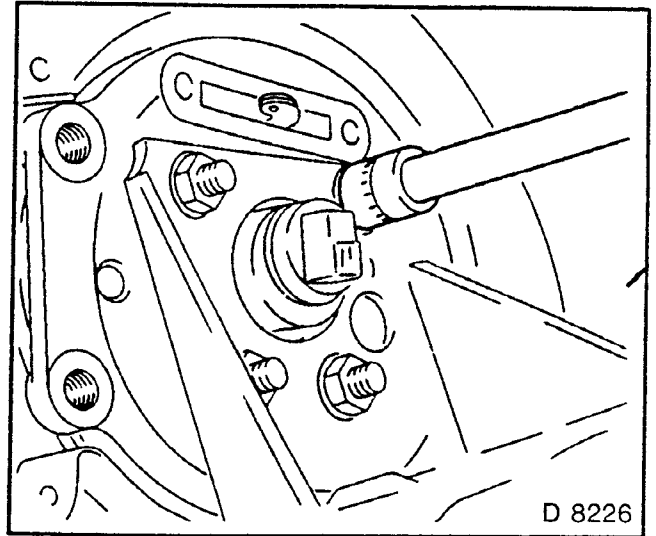


Fig. 11

**TIGHTEN, (TORQUE)**

1. Wheel bearing unit with brake backing plate/brake anchor plate to rear axle — 50 Nm + 30° to 45°, use new nuts.
2. Stop screw to wheel bearing unit (arrow) — 4 Nm for drum and disc brakes.
3. Stabilizer to rear axle — 30 Nm + 30° to 45°.
4. Additional stabiliser (where fitted) to rear axle — 60 N.m + 60° to 75°.

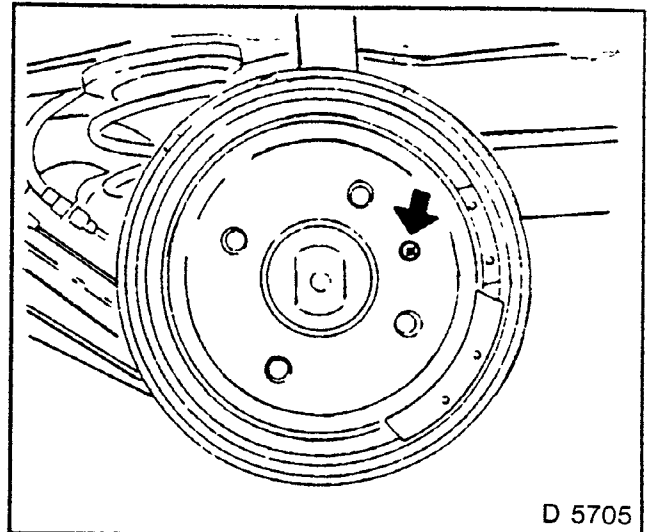


Fig. 12

**ASSEMBLE**

1. Parking brake cable in brake cable guide.

**INSTALL, CONNECT**

1. Rear axle to vehicle underbody.
2. Raise rear axle on centre — hydraulic jack.
3. Tighten bolts initially only.
4. Install springs with damping rings.
5. Place hydraulic jack under outriggers.

**TIGHTEN (TORQUE)**

1. Shock absorber to outrigger — 70 Nm.
2. Raise outrigger.
3. Fix installation position with drift.

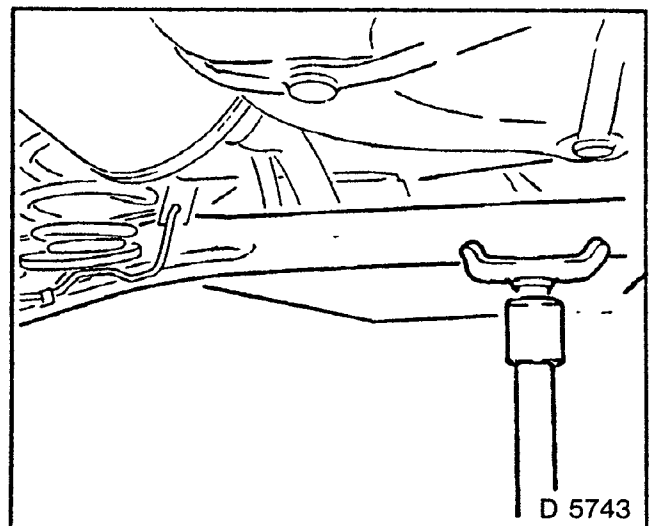


Fig. 13

**INSTALL, CONNECT**

1. Cable for ABS sensor to retainer.
2. Wiring harness plug for ABS sensor to wheel bearing unit.
3. Parking brake cable to tie rod — adjust brake cable compensating yoke.

**TIGHTEN (TORQUE)**

1. Secure brake lines to brake pressure hoses — 16 Nm

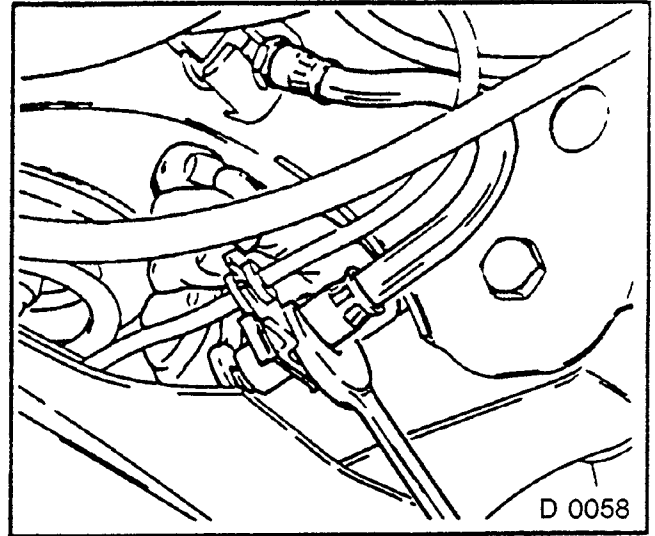


Fig. 14

**TIGHTEN (TORQUE)**

2. Rear axle to vehicle underbody — 105 Nm.  
Load each front seat with 70 kg.

**INSPECT**

1. Parking brake — adjust if necessary.
2. Bleed brake installation and check for leaks. See Section H.

Adjustment and functioning of load-dependent brake proportioning valve.

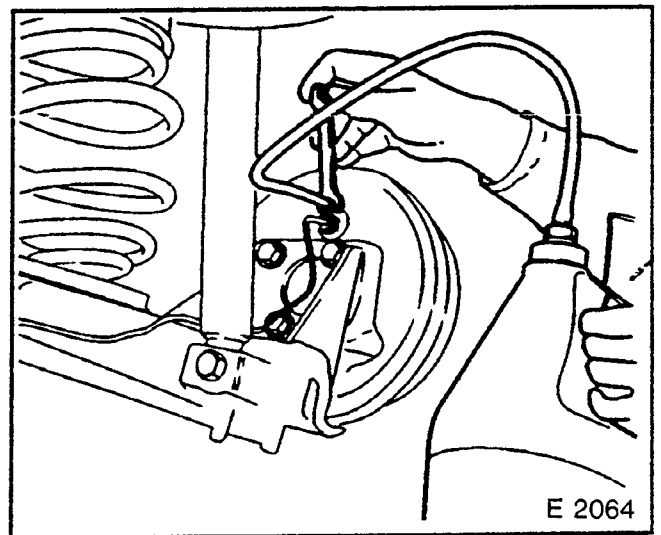


Fig. 15



## Rear Axle Damping Bushings, Replace

### REMOVE, DISCONNECT

1. Rear wheels.
2. Remove locking plates from brake lines.
3. Brake lines from retainers at underbody.
4. Rear axle from vehicle underbody
5. Place hydraulic jack centrally under rear axle.
6. Lever out bolts.
7. Lower rear axle slightly.
8. Connect KM—452—5 on one side.

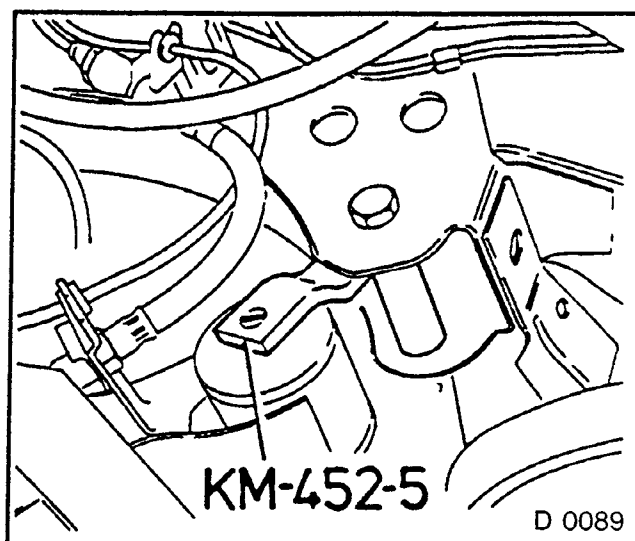


Fig. 16

9. Damping bushing from rear axle.
10. Saw off collar of damping bushing (plastic) (dotted line).
11. Connect KM—671 — installation position (arrow).
12. Heat seat of damping bushing at outrigger with hot air dryer — approx 70°C/158°F, thermocolour pencil, if present, or with suitable temperature gauge
13. Remove from rear axle by turning hex nut from KM—452—A.

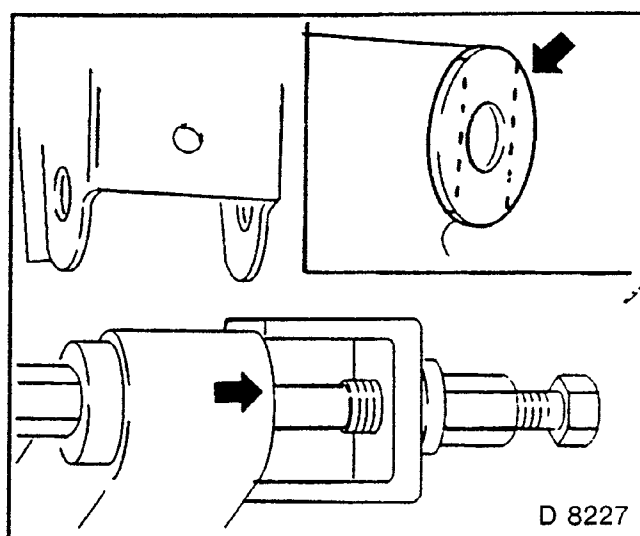


Fig. 17

### INSTALL, CONNECT

1. Draw damping bushing into rear axle with KM—671, coated with washing-up fluid — not grease, to prevent bushing turning as well.

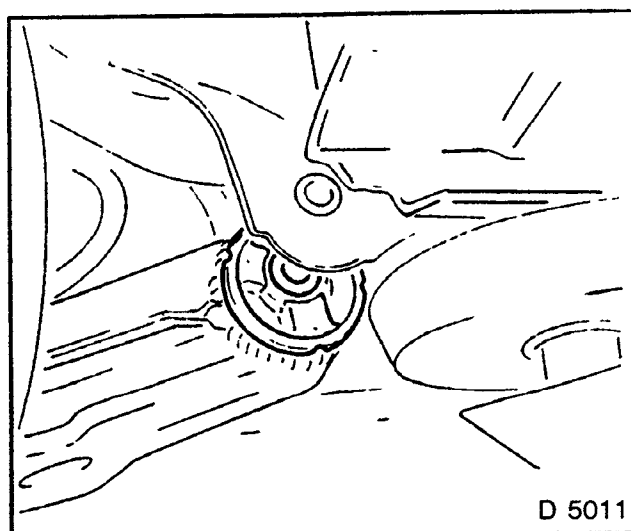


Fig. 18

**NOTE**

1. Note installation position: damping bushing is eccentric. The narrow part of the damping rubber points upwards.
2. Draw in up to position of collar on rear axle.
3. Fasten brake lines with locking plates.
4. Brake lines in brackets.

**TIGHTEN (TORQUE)**

1. Rear axle to vehicle underbody — 105 Nm.
2. Attach rear wheels — 110 Nm.
3. Load each front seat with 70 kg.

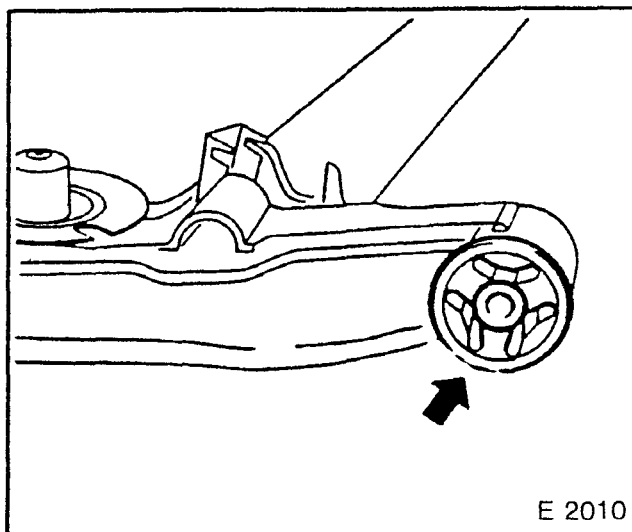


Fig. 19

## REAR SPRINGS

### Rear Springs and/or Damping Rings of Rear Springs — Remove and Install

Bleed air at filler valve on vehicles with vehicle level control.

#### REMOVE, DISCONNECT

- 1 Shock absorber from outrigger — support with hydraulic jack.
2. Rear spring with damping rings from spring seat.
3. Press rear axle with mounting iron as far down as possible, so that rear springs can be removed.

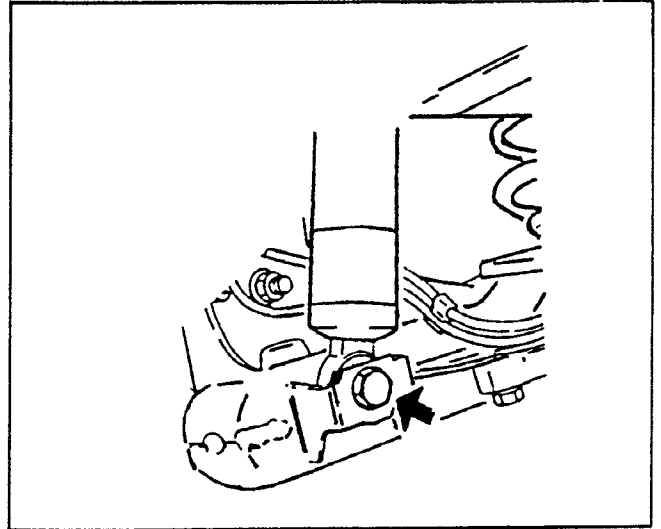


Fig. 20

#### INSTALL, CONNECT

- 1 Rear spring with damping rings in spring seat, simultaneously press down rear axle. Note installation position.

#### TIGHTEN (TORQUE)

1. Shock absorbers to outrigger — 70 Nm
2. Raise outrigger.

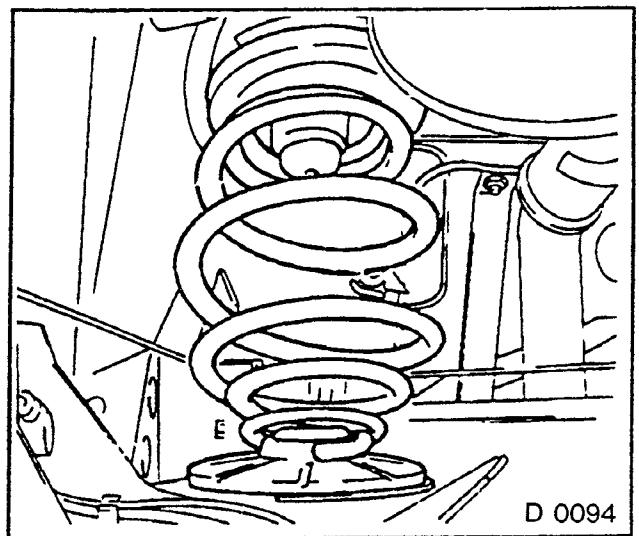


Fig. 21

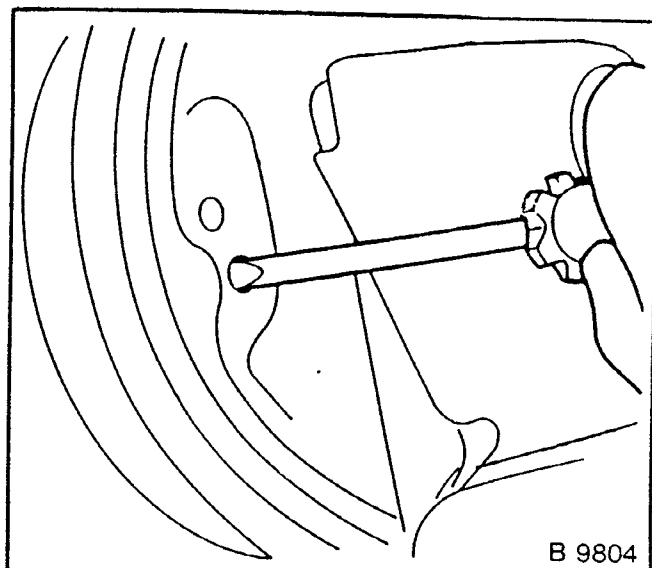
## WHEEL HUB, WHEEL BEARING, WHEEL SPINDLE, SEAL RING

### Rear Wheel Hub (Disc Hub), Replace One

1. Release parking brake
2. Raise vehicle.
3. Remove rear wheel.  
Mark installation position of rear wheels on hub.

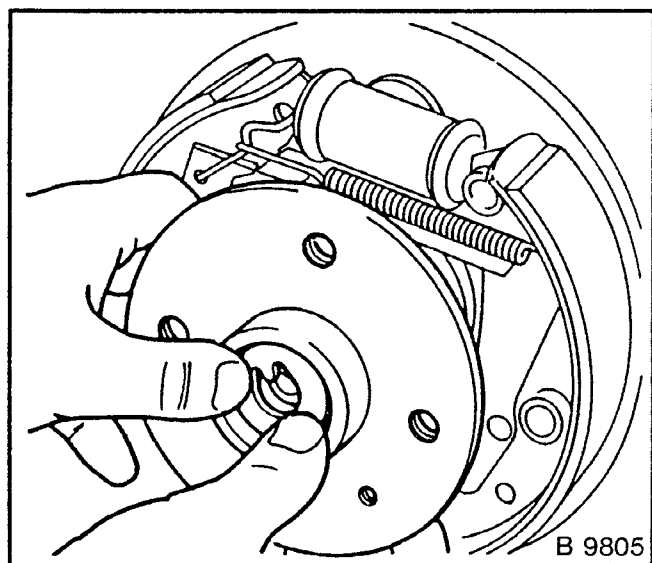
#### ON MODELS WITH DRUM BRAKES

1. Remove brake drum.
2. Unscrew retaining bolt.
3. Loosen parking brake cable at brake cable compensation yoke if required.
4. Press parking brake shoe lever inwards using screwdriver
  
5. Lever off dust cap from wheel hub
6. Remove split pin from wheel spindle nut and unscrew nut.
7. Remove wheel hub with lock washer from wheel spindle.
8. Clean wheel spindle and check visually for damage



B 9804

Fig. 22



B 9805

Fig. 23

**ON MODELS WITH DISC BRAKES****NOTE:**

**TO ENSURE EVEN BRAKING ON BOTH SIDES, BOTH DISC HUBS MUST HAVE THE SAME SURFACE AS REGARDS POLISHED SURFACE AND PEAK-TO-VALLEY HEIGHT. FOR THIS REASON, BOTH DISC HUBS MUST BE REPLACED IN EVERY CASE.**

1. Unbolt brake caliper and tie up with wire. Brake system remains closed.

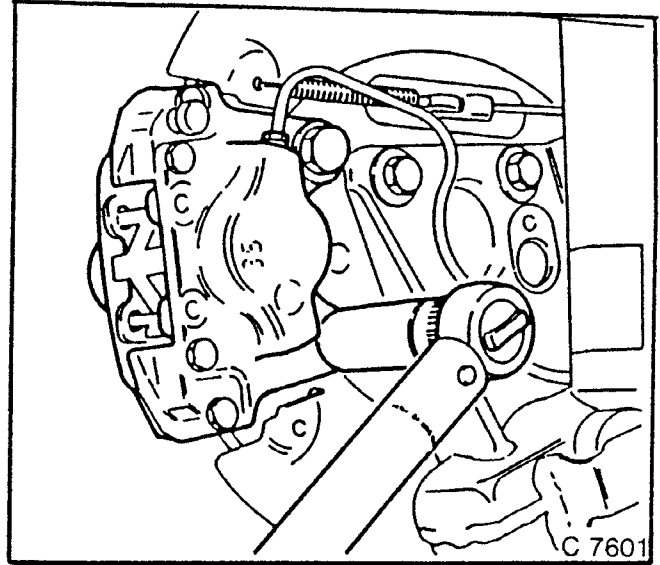


Fig. 24

2. Lever off dust cap.
3. Remove split pin from wheel spindle nut and unscrew nut.

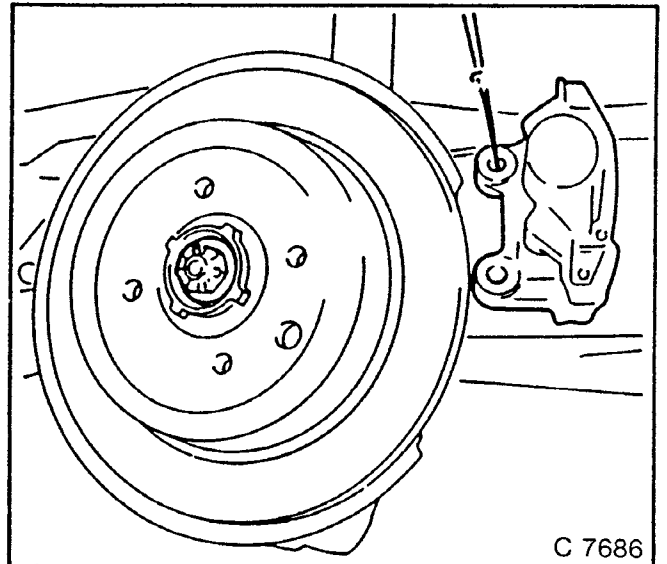


Fig. 25

4. Remove disc hub with lock washer from wheel spindle

If necessary detach parking brake cable from brake cable lever.

**NOTE:**

**IF THE DISC HUB CANNOT BE REMOVED, THE ADJUSTMENT SCREW OF THE PARKING BRAKE SHOE MUST BE LOOSENED. SEE SECTION H.**

5. Clean wheel spindle and check visually for damage.
6. Check parking brake shoe visually for wear. See Section H.

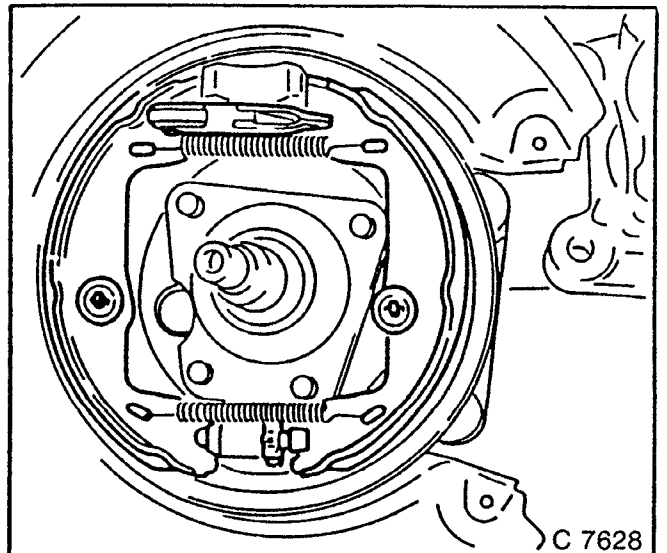


Fig. 26

**INSTALL**

**ON MODELS WITH DISC BRAKES**

- 1 Press outer race of **OUTER** bearing into disc hub as far as stop with KM-266-4 and KM-466-2.
- 2 Press outer race of **INNER** bearing into disc hub as far as stop with KM-266-4 and KM-466-2.

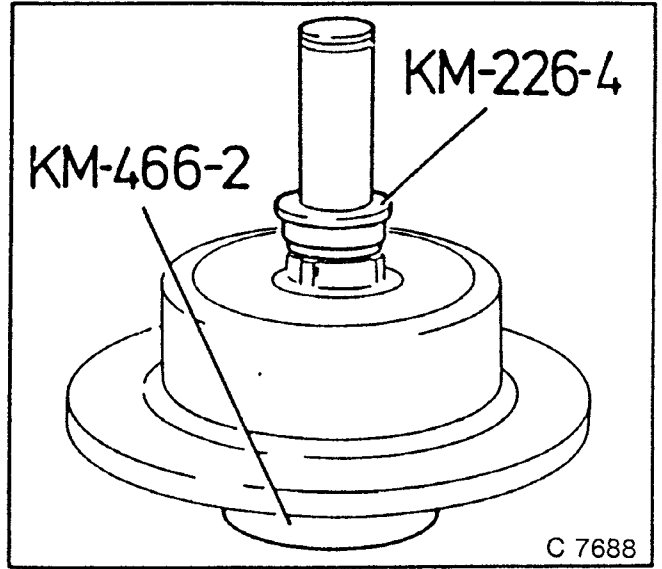


Fig. 27

3. Insert inner tapered roller bearing in disc hub
  4. Press seal ring with suitable sleeve into disc hub.
  5. Coat and/or fill both wheel bearings, sealing lip of seal ring and hollow space in disc hub with Lithium Grease.
  6. Place disc hub with lock washer on wheel spindle and screw on wheel spindle nut.
  7. Adjust wheel bearing.
  - 8 Attach parking brake cable "A" and return spring "B" to parking brake lever.
- If necessary adjust parking brake.  
See Section H.

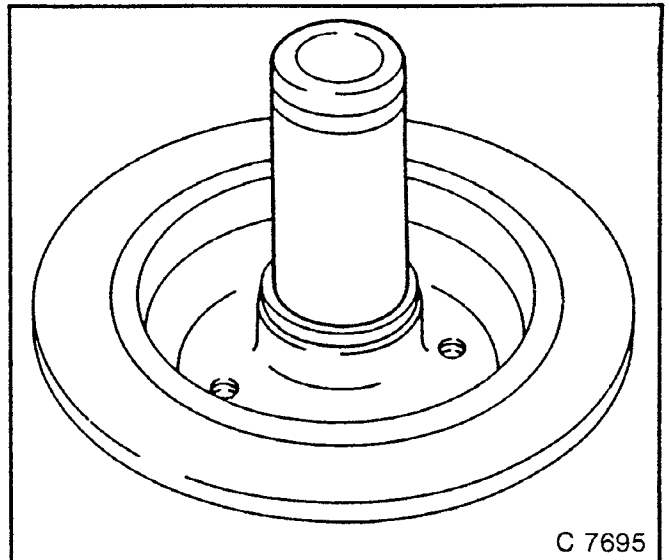


Fig. 28

9. Install brake caliper and tighten to torque of 65 Nm.

**NOTE:**  
**CHECK THAT BRAKE PADS ARE IN PERFECT CONDITION AND FREE OF WEAR.**  
**SEE SECTION H.**

10. Replace disc hub on other side in same way.
11. Replace rear wheels and tighten to torque of 90 Nm.
12. Lower vehicle.
13. Adjust air play by depressing brake pedal fully several times.

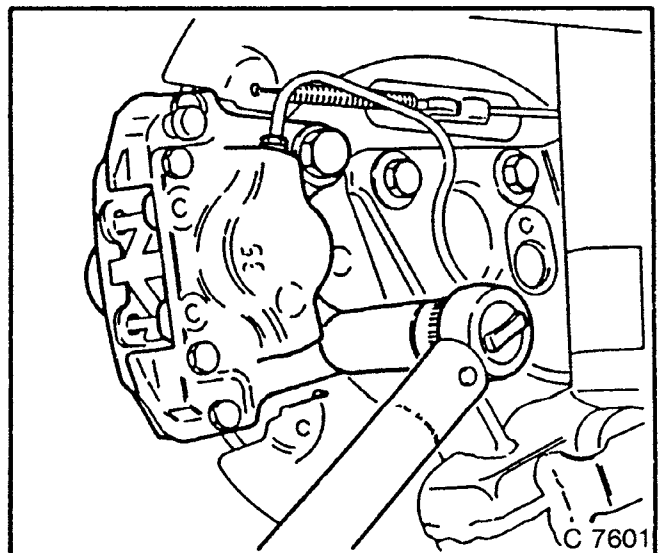


Fig. 29

**ON MODELS WITH DRUM BRAKES**

- 1 Press outer race of **OUTER** bearing into wheel hub as far as stop using KM—266—4.
2. Press outer race of **INNER** bearing into wheel hub as far as stop using KM—266—4
3. Insert inner tapered roller bearing in wheel hub.

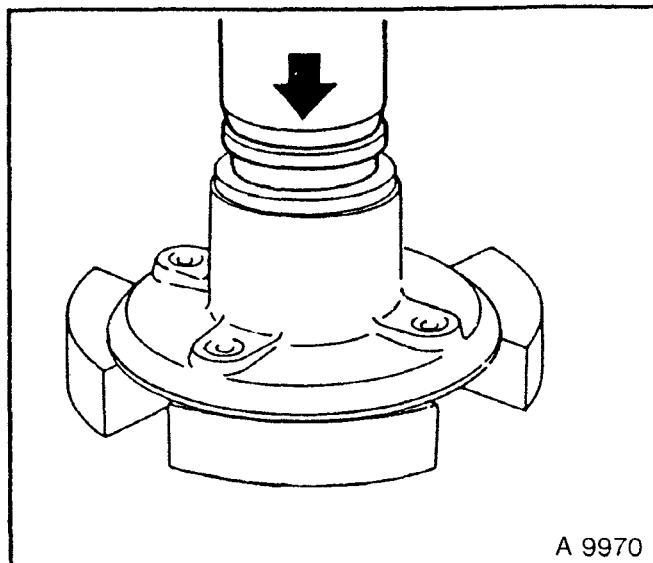


Fig. 30

4. Press seal ring into wheel hub using suitable sleeve
- 5 Coat/fill both wheel bearings, seal ring seal lip and wheel hub hollow space with Lithium Grease.
6. Tighten subsequent adjustment unit if required.
7. Place wheel hub with lock washer on wheel spindle.
8. Screw on wheel hub nut.
9. Mount brake drum. Tighten brake drum detent screw
10. Mount rear wheel and tighten — 90 Nm.
11. Adjust wheel bearing play
12. Lower vehicle.
13. Adjust rear wheel brake. Adjust parking brake if required.

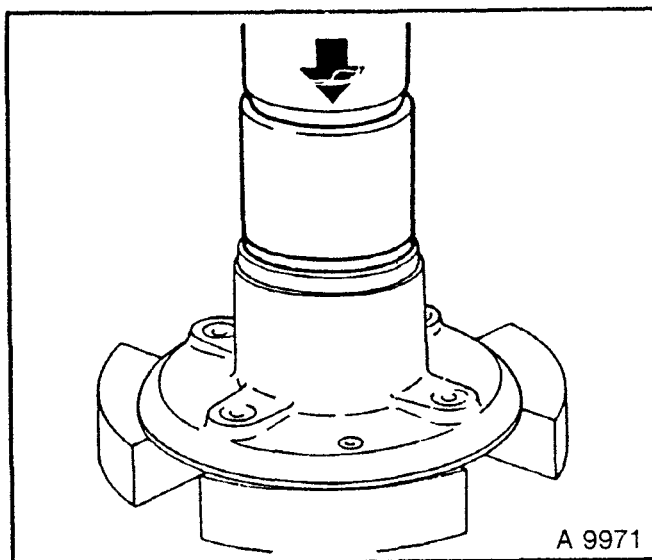


Fig. 31

## Wheel Spindle, Remove and Install or Replace

### ONLY ON MODELS WITH DISC BRAKES

As this operation is almost identical to the operation "Rear Wheel Hub, Replace One", in the following only the **ADDITIONAL** work required will be described. See page 15.

- 1 Loosen wheel spindle retaining bolts and remove.

**NOTE:**  
**USE NEW BOLTS EACH TIME THEY ARE LOOSENED.**

Remove wheel spindle.

Check wheel spindle visually and check if necessary for radial and lateral runout.

See appropriate operation on page 19.

Install wheel spindle.

**NOTE:**  
**MOUNTING SURFACES AND THREADS MUST BE FREE OF GREASE, PAINT AND OTHER IMPURITIES.**

Tighten new retaining bolts to torque of 50 Nm

Tighten further by  $30^\circ \pm 5^\circ$ .

Coat wheel spindle thinly in area of anchor plate with Antifriction Bearing Grease.

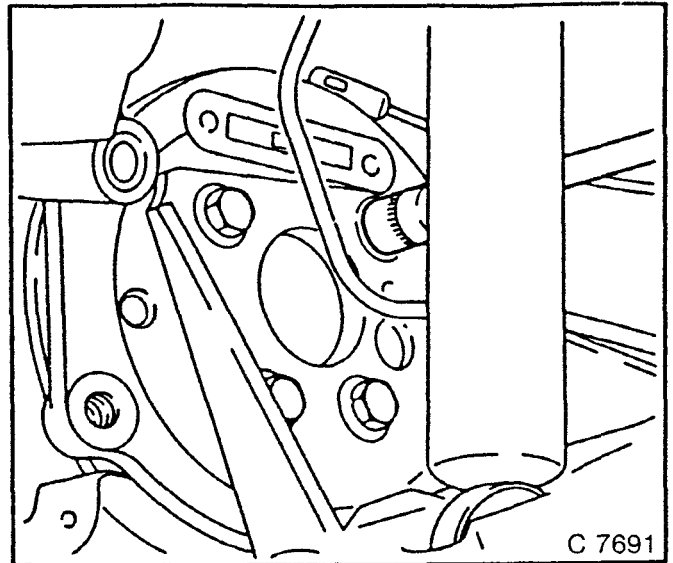


Fig. 32

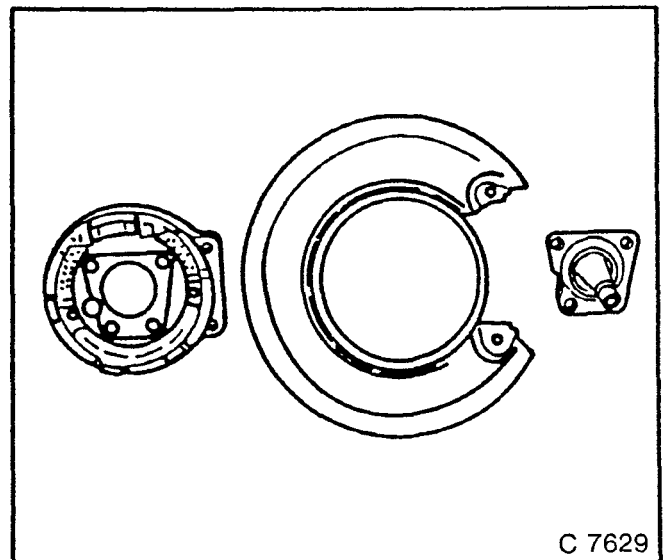


Fig. 33

## Wheel Bearings of Rear Wheel Hub (Disc Hub), Replace Both

Since this operation is basically identical to the operation "Rear Wheel Hub, Replace One", only the additional work required is described below.

### ON MODELS WITH DRUM BRAKES

1. Lever seal ring from wheel hub using screwdriver.
2. Remove inner tapered roller bearing from wheel hub.

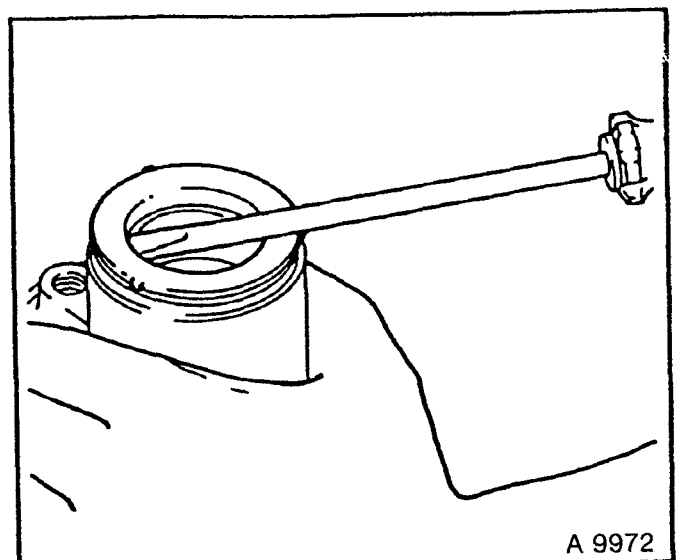


Fig. 34



3. Press outer race of inner bearing out of wheel hub using KM—266—2 and KM—266—3 in conjunction with KM—466—2.
4. Press outer race of outer bearing out of wheel hub using KM—266—1 and KM—266—3 in conjunction with KM—466—2.

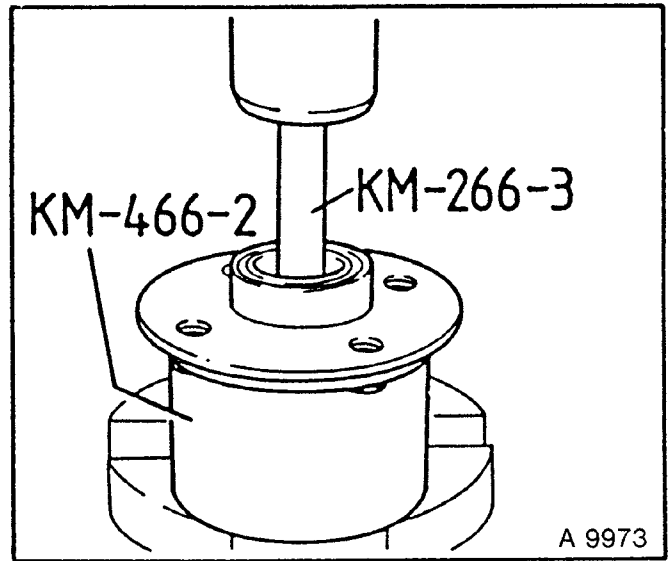


Fig. 35

#### ON MODELS WITH DISC BRAKES

1. Lever seal ring out of disc hub with mounting iron.
2. Remove inner tapered roller bearing from disc hub

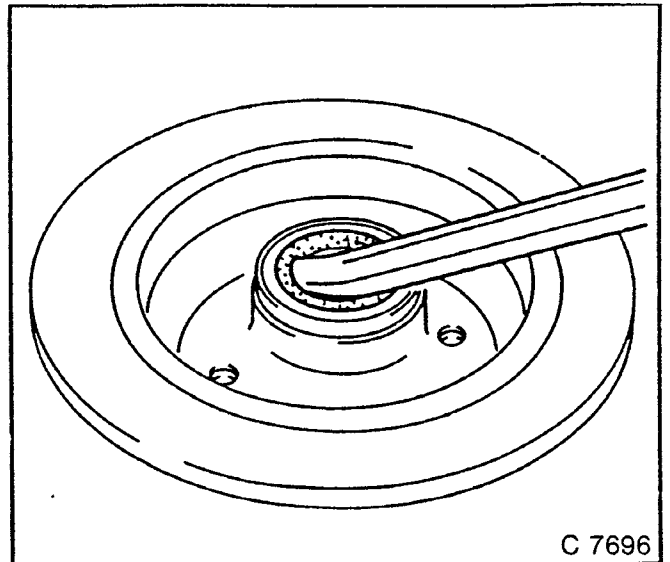


Fig. 36

3. Drive outer race of **INNER BEARING** out of disc hub with a soft metal drift (see fig. 39).

**NOTE:**  
TURNING DISC HUB WHILE DRIVING OUT RACE WILL PREVENT RACE FROM TWISTING.

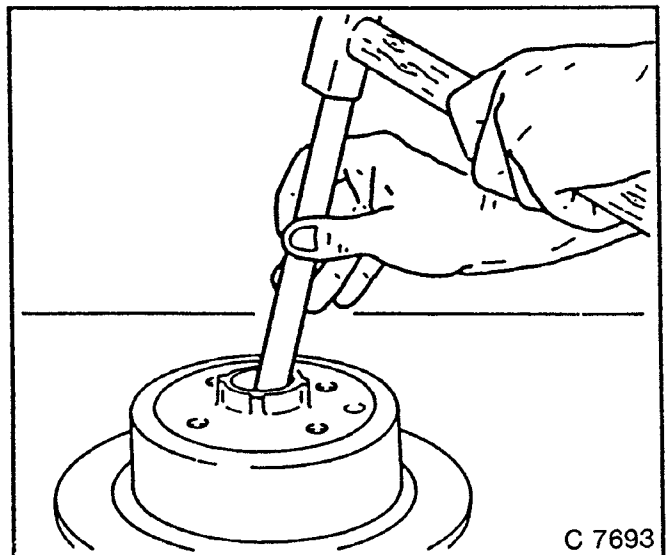


Fig. 37

4. Drive outer race of **OUTER BEARING** out of disc hub with a soft metal drift (see fig 39) or suitable length of pipe. Place KM—466—2 under it.

**NOTE:**  
**TURNING DISC HUB WHILE DRIVING OUT RACE WILL PREVENT RACE FROM TWISTING.**

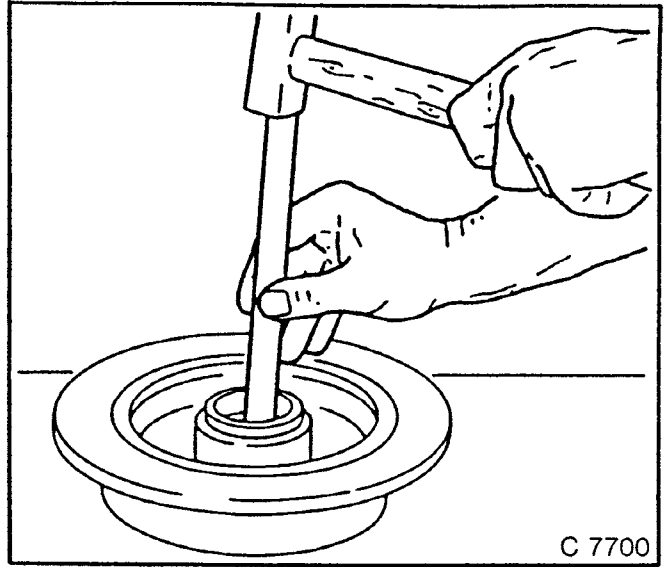


Fig. 38

If necessary, a soft metal drift can be made up using the measurements illustrated here.

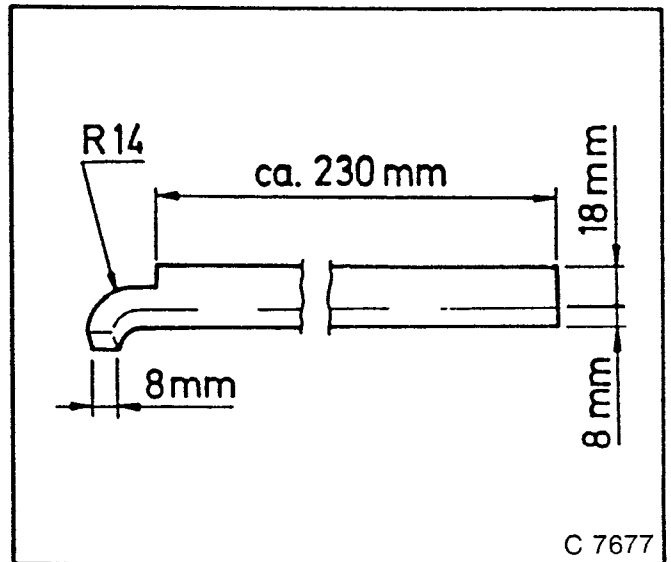


Fig. 39

## Seal Ring of One Rear Wheel Hub (Disc Hub), Replace

### ON MODELS WITH DRUM BRAKE

1. Remove wheel hub.  
 "Rear Wheel Hub, Replace One", page 15.
2. Lever seal ring from wheel hub.

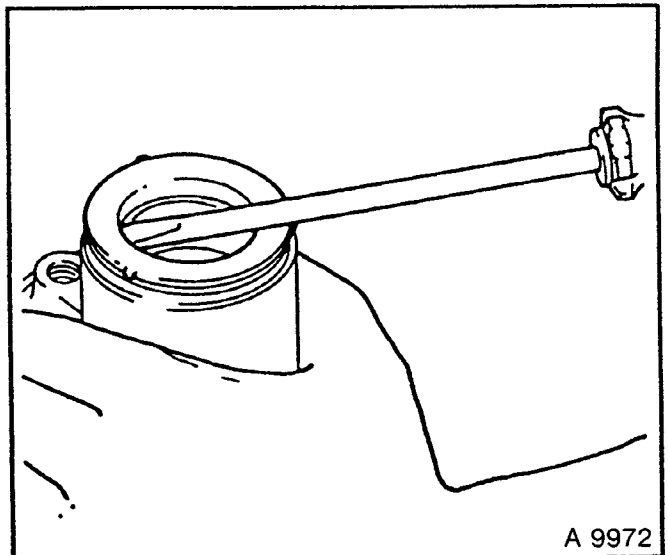


Fig. 40

3. Press seal ring into wheel hub using suitable sleeve.
4. Thinly coat seal lip of new seal ring with Lithium Grease.
5. Install wheel hub.  
See "Rear Wheel Hub, Replace One"  
Page 15.

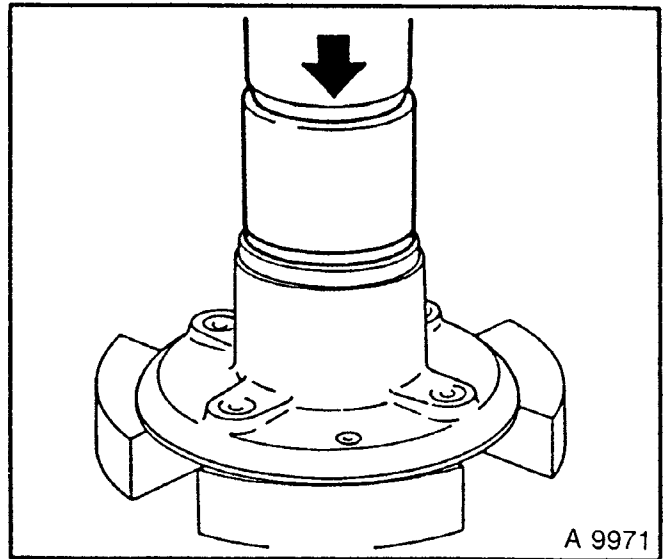


Fig. 41

#### ON MODELS WITH DISC BRAKES

- 1 Remove disc hub.  
See "Disc Hub, Replace One", page 15.
2. Lever seal ring off disc hub.

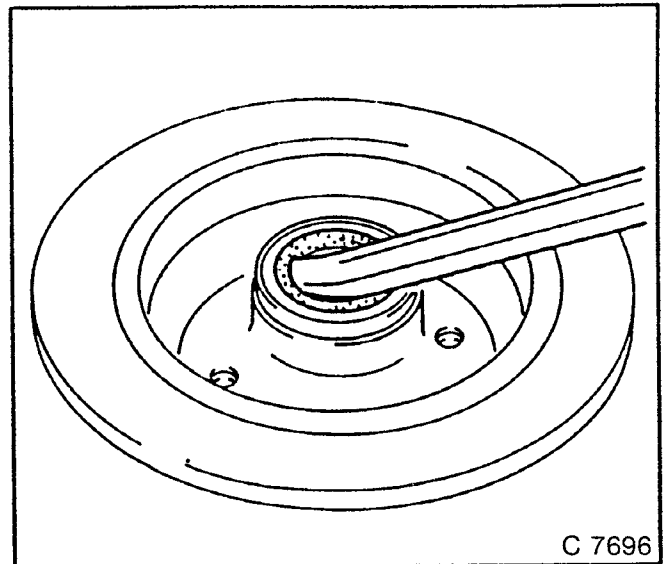


Fig. 42

3. Press seal ring into disc hub with suitable sleeve.
4. Coat sealing lip of new seal ring thinly with Lithium Grease.
5. Install disc hub.  
See "Disc Hub, Replace One" page 15.

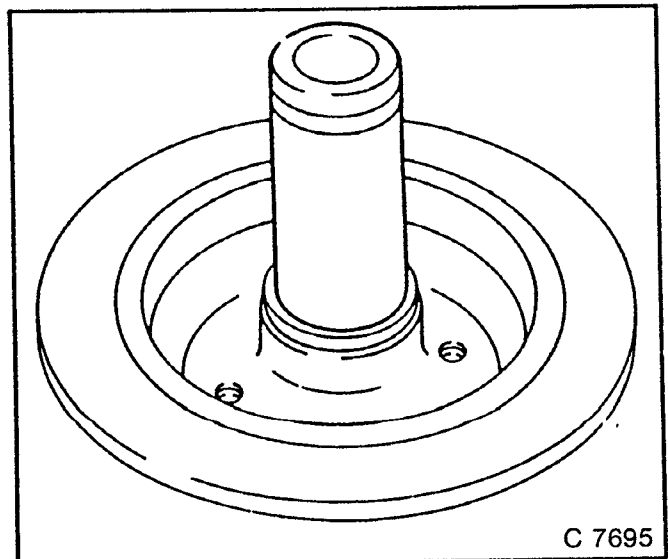


Fig. 43

## STABILIZER, SHOCK ABSORBER

### Shock Absorber and/or Rubber Buffer of Shock Absorber — Remove and Install

**NOTE:**  
**ONLY REMOVE SHOCK ABSORBERS ONE AT A TIME.**

#### REMOVE, DISCONNECT

- 1 Protective cap from shock absorber dome.
- 2 Shock absorber from underbody.
- 3 Washer and rubber buffer from shock absorber.  
 If rubber buffer only is to be replaced, raise vehicle slightly and pull shock absorber downwards.

- 4 Shock absorber from rear axle — mounting lever.
- 5 Place hydraulic jack under outrigger of rear axle.

#### TIGHTEN (TORQUE)

- 1 Shock absorber to rear axle — 70 Nm
- 2 Shock absorber to underbody — 20 Nm — with washer and rubber buffer.

#### INSTALL, CONNECT

Protective cap on shock absorber dome.

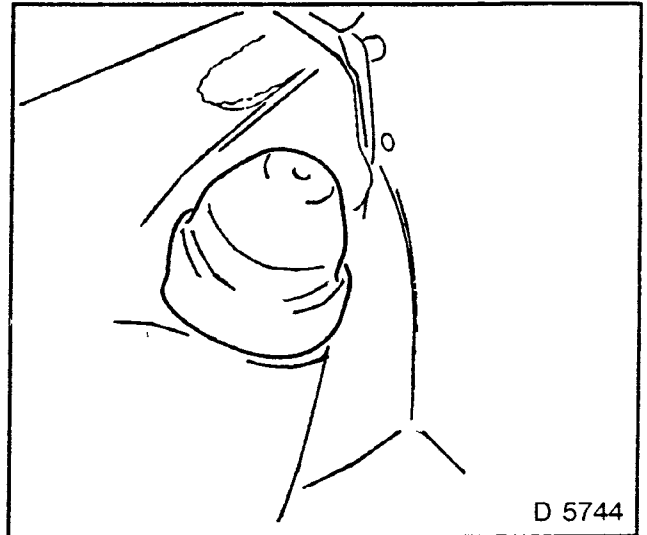


Fig. 44

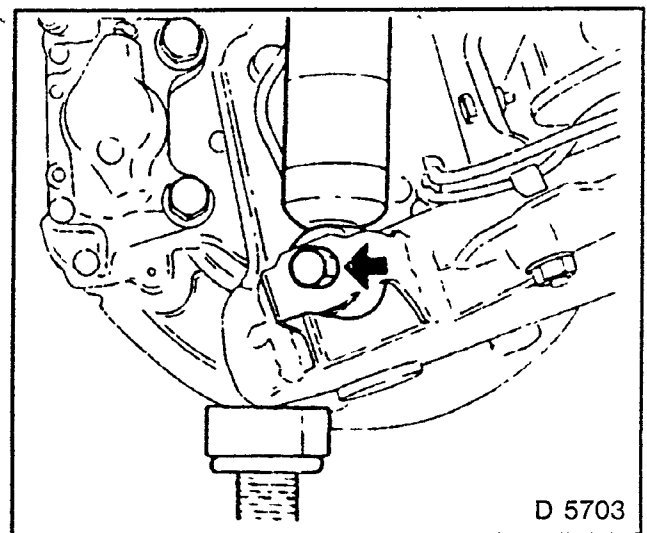


Fig. 45

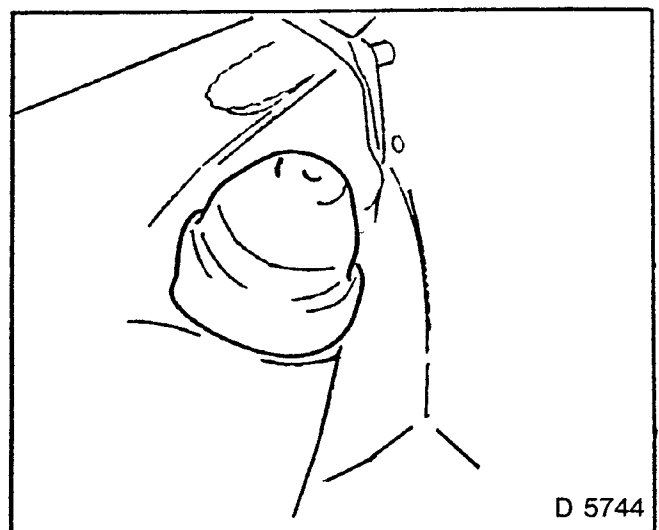


Fig. 46

## Stabilizer, Remove and Install

### REMOVE, DISCONNECT

1. One rear wheel.
2. Stabilizer mount on both sides of rear axle.
3. Rubber damper from rear axle body
4. Slide stabilizer out of one end of axle (towards side where stabilizer is flattened) for approximately 150 mm and then remove from open end of torsion profile.

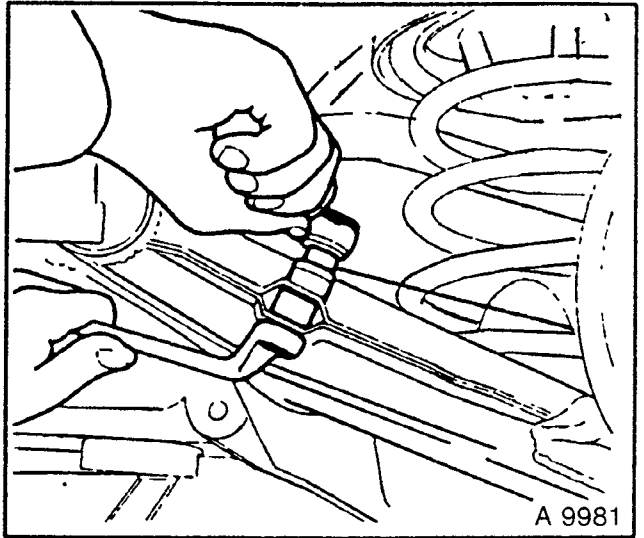


Fig. 47

### INSTALL, CONNECT

1. Stabilizer in rear axle body and damper  
For better mounting, thinly coat stabilizer with lubricating compound.

### TORQUE — ANGLE METHOD

1. Stabilizer to rear axle — 30 Nm + 30° to 45°
2. Rear wheel — 110 Nm.

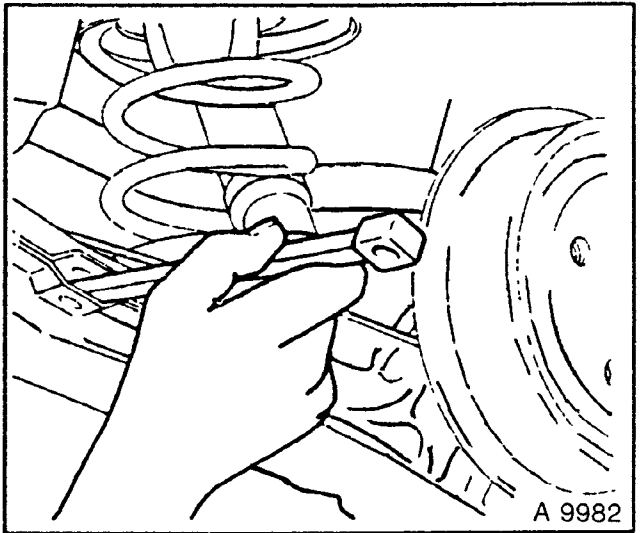


Fig. 48

## Additional Stabilizer, Remove and Install (where fitted)

### REMOVE, DISCONNECT

1. Additional stabilizer from rear axle (four fastening points — arrows).

### TORQUE — ANGLE METHOD

2. Additional stabilizer to rear axle — 60 Nm + 60° to 75°.

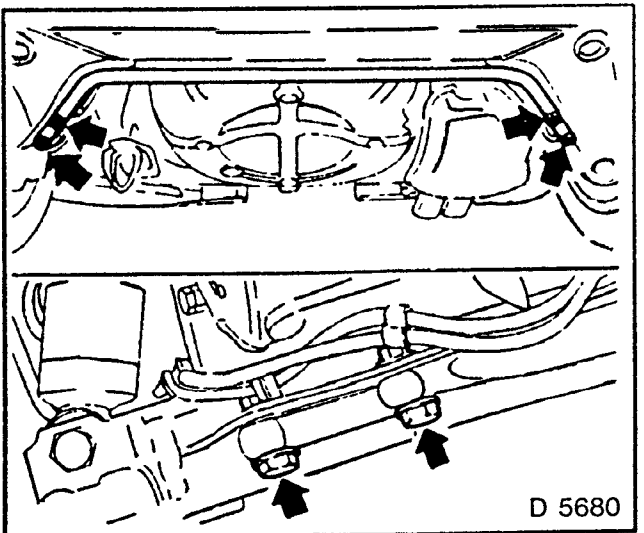
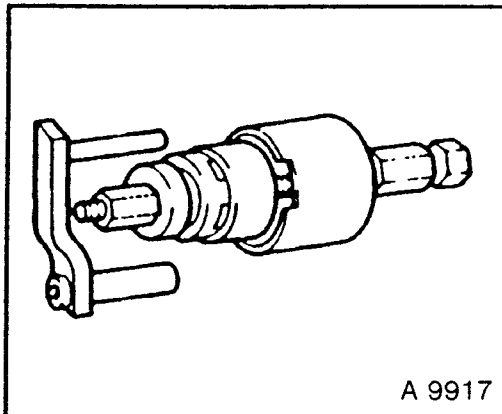


Fig. 49

## SPECIAL SERVICE TOOLS

**KM — 452 — A      Remover/Installer.**

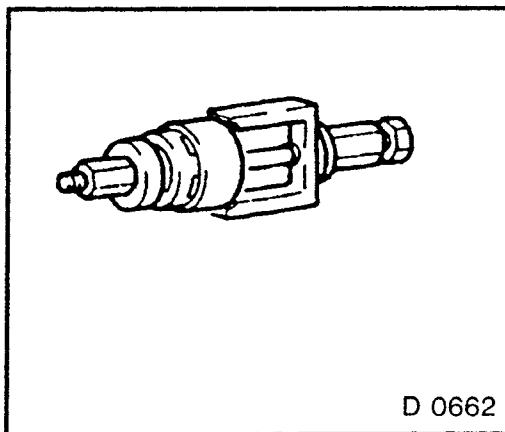
To remove and install rear axle damping bushings.



A 9917

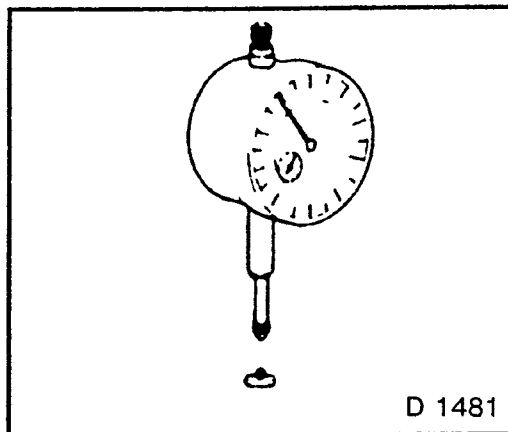
**KM — 671            Remover/Installer.**

To remove and install rear axle damping bushings.



D 0662

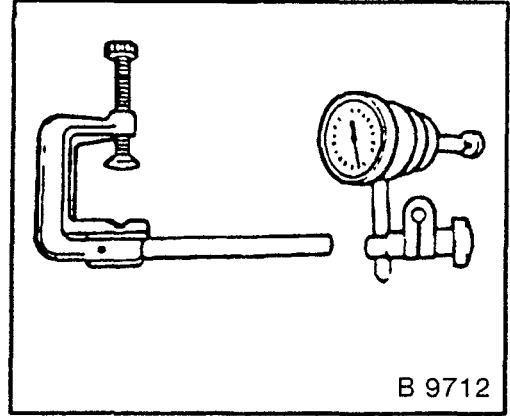
**MKM — 571 — B      Dial Gauge.**



D 1481

MKM — 572

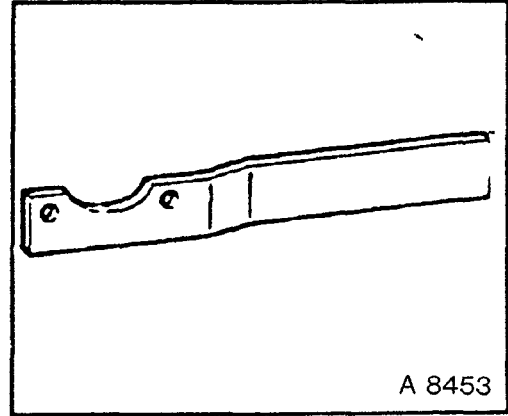
Dial Indicator.



B 9712

KM — 468

Holding Wrench.



A 8453

## TECHNICAL DATA

Camber, Toe-in, Check (not adjustable)

Wheel camber:	-1° 40'
Tolerance range	± 30'
	Variation from left to right wheel max. 0° 30'
Toe-in (applies to both wheels):	10' + 30'/-20' (approx. - 1 to + 4 mm)
Tolerance range	Variation from left to right wheel max. 0° 15'
Lateral run-out:	0,05 mm
Radial run-out:	0,05 mm

### CHECK CAMBER AND TOE-IN (NOT ADJUSTABLE)

	DRUM BRAKE	DISC BRAKE
<b>Camber:</b>	-0° 30'	-1° 40'
Tolerance range:	-1° to 0° (Deviation from left to right wheel max. 0° 30')	-2° 10' to -1° 10'
<b>Toe-in</b> (both wheels)	10' toe-out to 40' toe-in Deviation from left to right wheel max. 0° 15'	approx. -1 to + 4 mm

#### NOTE:

**TO CHECK CAMBER AND TOE-IN, LOAD EACH FRONT SEAT WITH 70 kg; THE TANK MUST BE HALF FULL.**

In vehicles with manual level control, a pressure of 100 kPa is to be maintained on the shock absorbers when making measurements.

In addition, ensure that the pressure in all four tyres corresponds to that specified in Group E for the particular model under a full load.

#### Marking of rear springs

Models	Identification	Part No.	No. of coils	Length in mm <sup>-20</sup> (unladen) <sup>-10</sup>
All models (excl 200i S & 200 TS)	AV	90 189 408	6,8	228
200iS	HU	90 372 592	6.4	191
200i TS	HU	90 372 592	6.4	191



# RECOMMENDED TORQUE VALUES

COMMENTS

	Nm
Additional stabilizer to rear axle .....	***
Brake caliper to brake backing plate .....	80
Brake disc to wheel bearing unit .....	4
Brake drum to wheel bearing unit .....	4
Brake line to brake pressure hoses.....	16
Rear axle to vehicle underbody .. . . . .	105
Shock absorber to rear axle.....	70
Shock absorber to underbody.. . . . .	20
Stabilizer to rear axle .....	**
Wheel bolt to wheel hub .....	110

\*\* Must be tightened in three stages: 30 Nm + 30° + 15°

\*\*\* Must be tightened in three stages: 60 Nm + 60° + 15°

# Index

Page

## OHC PETROL ENGINE

Illustrations . . . . . J- 1

## ENGINE CHECKING AND ADJUSTING OPERATIONS

Compression, Check . . . . . J- 9  
Engine Oil Consumption, Measure . . . . . J-13  
Engine Oil Pressure, Check . . . . . J-13  
Engine Oil Temperature, Measure . . . . . J-12  
Engine Pressure Loss, Check . . . . . J-11  
Recommended Torque Values . . . . . J- 7  
Ribbed V-Belt Tension, Check and Adjust (1,6ℓ with Air-conditioning) . . . . . J- 9  
Timing, Check and Adjust (1,4/1,6ℓ) . . . . . J-15  
Timing, Check and Adjust (1,8/2,0ℓ) . . . . . J-17  
Toothed Belt, Install and Tension (1,4/1,6/1,8/2,0ℓ with Toothed Belt Tension Roller) . . . . . J-18  
V-Belt Tension, Check and Adjust (except 1,6ℓ with Power Steering) . . . . . J 8

## ENGINE TIMING SIDE

Illustration . . . . . J-21  
Rear Toothed Belt Cover, Remove and Install (1,4/1,6/1,8/2,0ℓ with Toothed Belt Tension Roller) . . . . . J-22  
Recommended Torque Values . . . . . J-21  
Toothed Belt, Replace (1,4/1,6ℓ with Toothed Belt Tension Roller) . . . . . J-24  
Toothed Belt Tension Roller, Replace (1,4/1,6ℓ) . . . . . J-25

## CYLINDER HEAD, CAMSHAFT HOUSING

Illustrations . . . . . J-27  
Camshaft and Rocker Arm, Remove and Install . . . . . J-37  
Camshaft Housing, Replace . . . . . J-39  
Cylinder Head, Check for Plane Surface . . . . . J-49  
Cylinder Head, Disassemble and Assemble . . . . . J-45  
Cylinder Head, Overhaul . . . . . J-46  
Cylinder Head, Remove and Install . . . . . J-41  
Front Seal Ring in Camshaft Housing, Replace . . . . . J-31  
Fuel Pump, Replace (14NV) . . . . . J-37  
Gasket — Exhaust Manifold/Cylinder Head, Replace . . . . . J-32  
Gasket — Intake Manifold/Cylinder Head, Replace (C16SE) . . . . . J-33  
Hydraulic Valve Lash Adjuster, Replace . . . . . J-36  
Rear Seal Ring in Camshaft Housing, Replace (1,8/2,0ℓ) . . . . . J-30  
Recommended Torque Values . . . . . J-41  
Spark Plug Thread, Recondition . . . . . J-40  
Strainer (Filter) in Camshaft Housing Cover, Clean . . . . . J-47  
Valve Grind . . . . . J-46  
Valve Grind In . . . . . J-47  
Valve Guide, Ream . . . . . J-47  
Valve Seating, Mill . . . . . J-48

## CRANK DRIVE

Con-Rod Bearing, Replace . . . . . J-59  
Con-Rod, Replace . . . . . J-59  
Crankshaft, Check . . . . . J-63  
Crankshaft, Remove and Install . . . . . J-61  
Drive Disc, Remove and Install (18SE only) . . . . . J-51  
Engine Block, Check for Plane Surface . . . . . J-58  
Flywheel, Remove and Install (1,6ℓ Engine) . . . . . J-65  
Flywheel, Remove and Install (Except for 1,6ℓ Engine) . . . . . J-65  
Piston with Con-Rod, Remove and Install (Engine Installed) . . . . . J-56  
Piston Rings, Replace . . . . . J-57  
Recommended Torque Values . . . . . J-50  
Seal Ring, Crankshaft, Front (In Oil Pump Housing), Replace . . . . . J-52  
Seal Ring, Crankshaft, Rear, Replace (1,6ℓ Engine) . . . . . J-53  
Seal Ring, Crankshaft, Rear, Replace (MT except for 1,6ℓ Engine) . . . . . J-54  
Starter Ring Gear, Replace . . . . . J-50

**OIL CIRCUIT**

By-pass Valve, Replace . . . . .	J-67
Oil Filter Cartridge, Replace . . . . .	J-66
Oil Pump, Check . . . . .	J-68
Oil Pump, Remove and Install . . . . .	J-67
Oil Pump Safety Valve, Replace . . . . .	J-68
Recommended Torque Values . . . . .	J-66

**COOLING SYSTEM**

Coolant Temperature, Measure with Closed Cooling System . . . . .	J-71
Cooling System, Top Up and Bleed . . . . .	J-70
Cooling System, Check for Leaks . . . . .	J-71
Fan Motor, Replace . . . . .	J-71
Radiator, Remove and Install . . . . .	J-69
Recommended Torque Values . . . . .	J-69
Thermostat, Replace (1,4/1,6 $\phi$ ) . . . . .	J-72
Thermostat, Replace (1,8/2,0 $\phi$ ) . . . . .	J-73
Water Pump, Remove and Install . . . . .	J-73

**ENGINE DAMPING BLOCKS, ENGINE, SHORT-BLOCK**

Engine, Repair Using Short Block . . . . .	J-81
Engine without Transmission, Remove and Install (1,4/1,6 $\phi$ ) . . . . .	J-76
New Short Block — Complete . . . . .	J-82
Recommended Torque Values . . . . .	J-76

**2 E 3 CARBURETTOR (14 NV)****CHECKING AND ADJUSTING OPERATIONS**

Basic Adjustment of Throttle Valve, Stage II, Check . . . . .	J-90
Carburettor Actuation, Adjust . . . . .	J-97
Choke Cover Position, Check . . . . .	J-89
Choke Valve Forced Opening, Adjust . . . . .	J-88
Choke Valve Gap, Check and Adjust . . . . .	J-87
Cold Start Adjustment, Throttle Valve Gap, Check and Adjust . . . . .	J-89
Enrichment Pipe, Check and Adjust . . . . .	J-97
Fast Idle, Check and Adjust . . . . .	J-85
Float Level, Check . . . . .	J-97
Idle Speed and CO Content in Exhaust, Adjust . . . . .	J-85
Injection Quantity, Check and Adjust . . . . .	J-90
Position of Stepped Plate, Check and Adjust . . . . .	J-88
Pulldown Unit, Check . . . . .	J-86
Pull Rod for Stage II, Check . . . . .	J-91
Release and Forced Return, Stage II, Check and Adjust . . . . .	J-91
Thermo Time Valve, Check . . . . .	J-86
Vacuum Unit II. Stage, Check for Leaks . . . . .	J-92

**REPAIR OPERATIONS**

2 E 3 Carburettor, Remove and Install . . . . .	J-93
Accelerator Pipe, Remove and Install . . . . .	J-96
Accelerator Pump, Remove and Install . . . . .	J-91
Carburettor Cover, Remove and Install (Carburettor Removed) . . . . .	J-94
Choke Body, Remove and Install . . . . .	J-93
Enrichment Valve, Remove and Install . . . . .	J-92
Filter in Fuel Feed, Remove and Install . . . . .	J-97
Float, Remove and Install . . . . .	J-94
Idler Nozzle, Remove and Install . . . . .	J-95
Main Nozzles, Remove and Install . . . . .	J-95
Pre-Atomizer, Remove and Install . . . . .	J-95
Pulldown Unit, Remove and Install . . . . .	J-93
Thermo Time Valve, Remove and Install . . . . .	J-87
Troubleshooting Chart (2E 3 Carburettor) . . . . .	J-98
Vacuum Unit II, Stage, Remove and Install . . . . .	J-92

**MULTEC CENTRAL FUEL INJECTION**

Arrangement of Throttle Valve Injection Housing	J-100
Control Unit, Remove and Install	J-101
Fuel Pressure Check	J-104
Fuel Pressure Regulator, Fuel Pressure Regulator Diaphragm, Remove and Install	J-104
General Information	J-101
Idle Air Control Stepper Motor, Remove and Install	J-105
Injection Valve, Remove and Install	J-103
Multec Central Fuel Injection (C16NZ)	J-100
Throttle Valve Injection Housing, Remove and Install	J-102
Throttle Valve Injection Housing Upper Part, Remove and Install	J-105
Throttle Valve Potentiometer, Remove and Install	J-103

**MULTEC M**

Fuel pressure, Check	J-109
Fuel Pressure Regulator, Remove and Install	J-109
Idle Air Control Stepper Motor, Remove and Install	J-108
Throttle Valve Potentiometer, Remove and Install	J-108

**MOTRONIC M 1.5.4 (C18SE/20SEH/20XELN)**

Coolant Temperature Sensor, Remove and Install	J-117
Fuel Pressure, Check	J-113
Fuel Pressure Regulator, Remove and Install	J-111
Hot Film Mass Air Flow Meter, Remove and Install	J-111
Idle Speed Adjuster, Remove and Install	J-112
Injection Valve, Remove and Install	J-114
Motronic M 1.5.4 (18SE/20SEH)	J-110
Motronic M 1.5.4	J-107
Tank Vent Valve, Remove and Install	J-114
Throttle Body, Remove and Install	J-112
Throttle Valve Potentiometer, Remove and Install	J-115

**MOTRONIC M 1.5.4 (C 16 SE)**

Bosch M 1.5.4 (C16SE)	J-116
Coolant Temperature Sensor — Remove and Install (C16SE)	J-117
Coolant Temperature Sensor — Remove and Install (C16NZ)	J-118
Coolant Temperature Sensor — Remove and Install (18SE/20SEH)	J-119
Control Unit — Remove and Install (18SE/20SEH)	J-119
Control Unit — Remove and Install (C16SE)	J-119
Dual Spark Ignition Coil, Remove and Install (C16SE)	J-123
Gap between Inductive Pulse Pick-Up and Increment Disc — Check (C16SE)	J-124
High Voltage Distributor, Remove and Install (18SE/20SEH)	J-122
Inductive Pulse Pick-Up, Remove and Install (C16SE)	J-124
Inductive Pulse Pick-Up, Remove and Install (18SE/20SEH)	J-125
Intake Air Temperature Sensor, Remove and Install	J-117
Intake Air Temperature Sensor, Remove and Install (16NZ/18SE/20SEH)	J-117
Intake Manifold Pressure Sensor, Remove and Install (C16SE/C16NZ)	J-120
Octane Number Plug Code (All Except 14NV)	J-125

**TRANSISTOR IGNITION (14NV)**

Ignition Basic Adjustment	J-121
Ignition Coil, Remove and Install (14NV, 18SE, 20SEH)	J-122
Ignition Coil, Remove and Install (C16NZ)	J-123
Ignition Distributor, Remove and Install (14NV/C16NZ)	J-121

**STARTER**

Illustrations . . . . .	J-126
Bearing Bushings, Replace (Bosch Starter) . . . . .	J-132
Bosch Reduction Gear Starter, Disassemble and Assemble . . . . .	J-137
Bosch Starter, Disassemble and Assemble . . . . .	J-134
Carbon Brushes, Replace (Bosch Starter) . . . . .	J-131
Field Winding, Replace . . . . .	J-131
Starter, Check (Installed) . . . . .	J-129
Starter, Check (Removed and Disassembled) . . . . .	J-129
Starter, Remove and Install . . . . .	J-128

**ALTERNATOR**

Alternator, Remove and Install . . . . .	J-143
Bosch Alternator . . . . .	J-142
Bosch Alternator, Check . . . . .	J-143
Bosch Alternator, Disassemble and Assemble . . . . .	J-145
Bosch Alternator, Overhaul . . . . .	J-150

**SPECIAL SERVICE TOOLS**

J-154

**TECHNICAL DATA**

J-312

**DOHC PETROL ENGINE**

Illustrations . . . . .	J-170
-------------------------	-------

**ENGINE CHECKING AND ADJUSTING OPERATIONS**

Compression Check . . . . .	J-176
Engine Oil Consumption, Measure . . . . .	J-181
Engine Oil Pressure, Check . . . . .	J-180
Engine Oil Temperature, Measure . . . . .	J-180
Engine Pressure Loss, Check . . . . .	J-177
Recommended Torque Values . . . . .	J-176
Timing, Check and Adjust . . . . .	J-182

**ENGINE TIMING SIDE — AIR CLEANER HOUSING**

Air Cleaner Housing, Remove and Install (C20LET) . . . . .	J-189
Recommended Torque Values . . . . .	J-184
Toothed Belt Guide Roller, Replace . . . . .	J-188
Toothed Belt, Replace . . . . .	J-184
Toothed Belt Tension Roller, Replace . . . . .	J-187

**CYLINDER HEAD**

Camshaft Seal Ring, Replace . . . . .	J-190
Camshaft Sprockets, Remove and Install . . . . .	J-197
Cylinder Head, Check for Plane Surface . . . . .	J-211
Cylinder Head, Disassemble and Assemble . . . . .	J-204
Cylinder Head, Overhaul . . . . .	J-208
Cylinder Head, Remove and Install . . . . .	J-198
Exhaust Camshaft, Replace . . . . .	J-195
Exhaust Valve (Sodium Filled), Disposal . . . . .	J-208
Gasket, Intake Manifold/Cylinder Head, Replace (20LET) . . . . .	J-190
Inlet Camshaft, Replace . . . . .	J-195
Recommend Torque Values . . . . .	J-189
Valve, Grind . . . . .	J-208
Valve, Grind In . . . . .	J-208
Valve, Guide, Ream . . . . .	J-209
Valve Seat, Cut . . . . .	J-209

**CRANK DRIVE**

Con-Rod, Replace .....	J-217
Con-Rod Bearing, Replace .....	J-217
Crankshaft Front Seal Ring (Oil Pump Housing), Replace .....	J-213
Cylinder Block, Check for Plane Surface .....	J-219
Flywheel, Remove and Install .....	J-218
Piston with Con-Rod, Remove and Install .....	J-216
Pot Flywheel, Remove and Install .....	J-219
Rear Crankshaft Seal Ring, Replace .....	J-211
Recommended Torque Values .....	J-211
Seal Ring, Rear Crankshaft, Replace (Version with Pot Flywheel) ..	J-213

**OIL CIRCUIT**

By-pass Valve, Replace .....	J-221
Gasket, Oil Pan, Replace .....	J-224
Oil Pump, Remove and Install .....	J-222
Oil Pump, Safety Valve, Replace .....	J-227
Recommended Torque Values .....	J-220
Thermostat, Replace .....	J-226

**COOLING SYSTEM**

Coolant Temperature, Measure with Closed Cooling System .....	J-229
Cooling System, Top Up and Bleed .....	J-229
Recommended Torque Values .....	J-227
Seal Ring-Thermostat Housing/Cylinder Head, Replace .....	J-228
Thermostat, Replace .....	J-230
Water Pump, Remove and Install .....	J-230

**ENGINE DAMPING BLOCKS — ENGINE — SHORT BLOCK**

Engine, Repair using Short Block .....	J-242
Engine with Transmission, Remove and Install (20LET with Pot Flywheel) .....	J-223
New Short Block, Complete .....	J-245
Recommended Torque Values .....	J-232

**MOTRONIC M 1.5.4 (20XE)**

Coolant Temperature Sensor, Remove and Install .....	J-259
Control Unit, Remove and Install .....	J-259
Fuel Pressure, Check .....	J-258
Fuel Pressure Regulator, Remove and Install .....	J-257
High Voltage Distributor, Remove and Install (2,0ℓ with Motronic M 1.4/M 1.5) ..	J-255
Hot Wire Mass Air Flow Meter, Remove and Install .....	J-255
Idle Speed Adjuster, Remove and Install .....	J-258
Ignition Coding Plug .....	J-257
Induction Pulse Pick-Up, Remove and Install .....	J-256
Injection Valves, Remove and Install .....	J-252
Knock Sensor, Remove and Install .....	J-256
Pre-Volume Chamber, Remove and Install .....	J-260
Throttle Body, Remove and Install .....	J-251
Throttle Valve Switch, Adjust .....	J-252
Throttle Valve Switch, Remove and Install .....	J-251

**TURBOCHARGING SYSTEM (C20LET)**

Charge Cooler, Remove and Install . . . . . J-271  
 Coolant Feed Line (Turbocharger), Remove and Install . . . . . J-271  
 Coolant Return Line (Turbocharger), Remove and Install . . . . . J-270  
 Gasket, Exhaust Manifold/Cylinder Head, Replace . . . . . J-273  
 Important Repair Instructions . . . . . J-269  
 Oil Feed Line (Turbocharger), Remove and Install . . . . . J-273  
 Oil Return Line (Turbocharger), Remove and Install . . . . . J-273  
 Overall Survey of Pressure and Vacuum Hoses . . . . . J-263  
 Recommended Torque Values, Turbocharging System . . . . . J-269  
 Survey of Pressure/Vacuum Hoses . . . . . J-264  
 Survey, Turbocharger Attaching Parts . . . . . J-266  
 Water Cooler, Remove and Install . . . . . J-272

**MOTRONIC 2.7 (20LET) INJECTION SYSTEM**

Illustrations . . . . . J-278  
 By-pass Valve, Charge Pressure Control, Remove and Install . . . . . J-296  
 Coolant Temperature Sensor, Remove and Install . . . . . J-295  
 Control Unit, Remove and Install . . . . . J-292  
 Fuel Pressure, Check . . . . . J-292  
 Fuel Pressure Regulator, Remove and Install . . . . . J-293  
 Fuel Pump Relay, Remove and Install . . . . . J-289  
 Hot Start Valve, Remove and Install . . . . . J-289  
 Hot Wire Mass Air Flow Meter, Remove and Install . . . . . J-289  
 Idle Speed Adjuster, Remove and Install . . . . . J-293  
 Ignition Coil, Remove and Install . . . . . J-291  
 Inductive Pulse Pick-Up, Remove and Install . . . . . J-286  
 Injection Valves, Remove and Install . . . . . J-295  
 Intake Air Temperature Sensor, Remove and Install . . . . . J-294  
 Tank Vent Valve, Remove and Install . . . . . J-281  
 Throttle Body, Remove and Install . . . . . J-286  
 Throttle Valve Potentiometer, Remove and Install . . . . . J-286

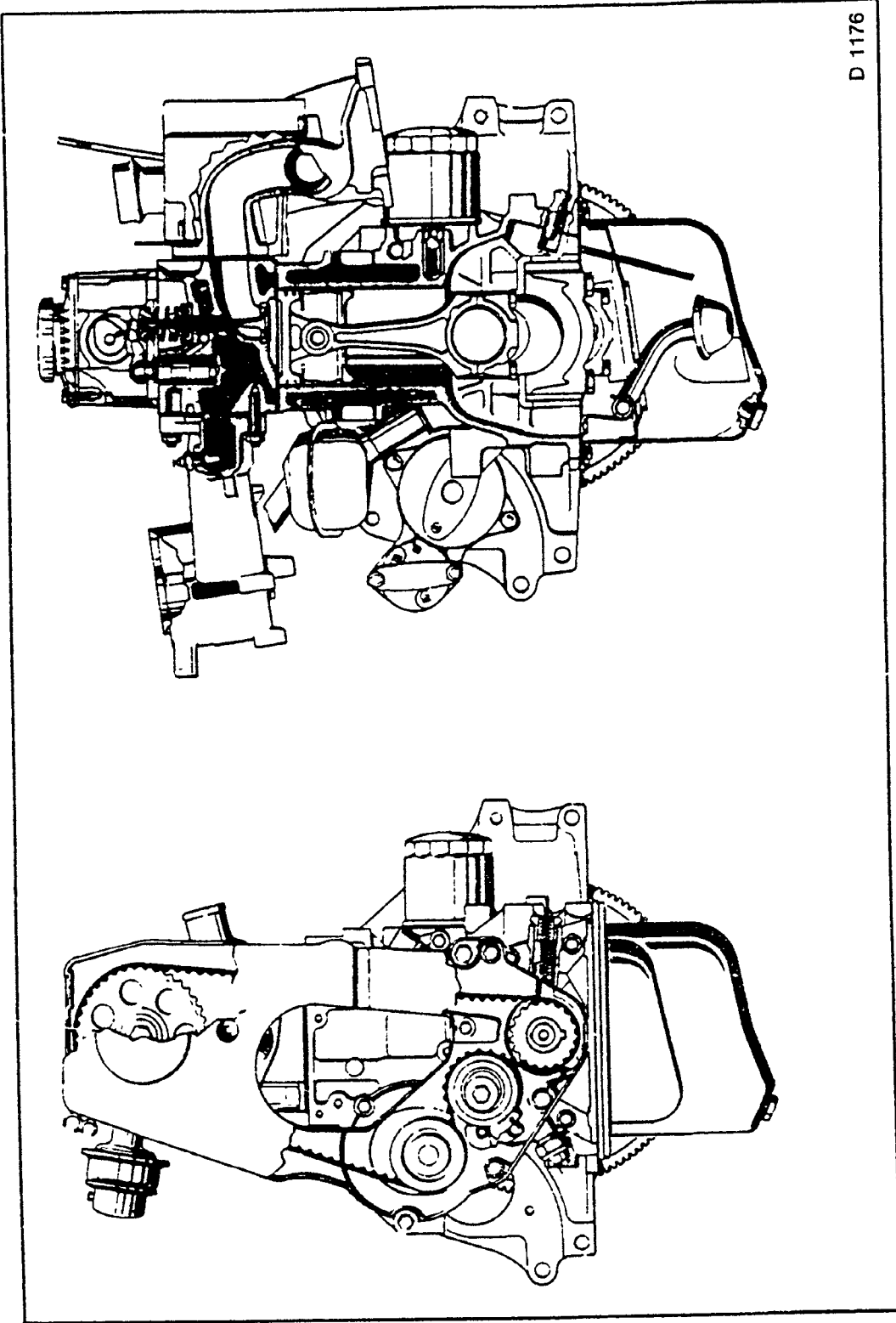
ALTERNATOR, REMOVE AND INSTALL . . . . . J-297  
 STARTER, REMOVE AND INSTALL . . . . . J-297  
 SPECIAL TOOLS . . . . . J-299  
 TECHNICAL DATA . . . . . J-312

14 NV

ILLUSTRATIONS

Cross Section

Engine Timing

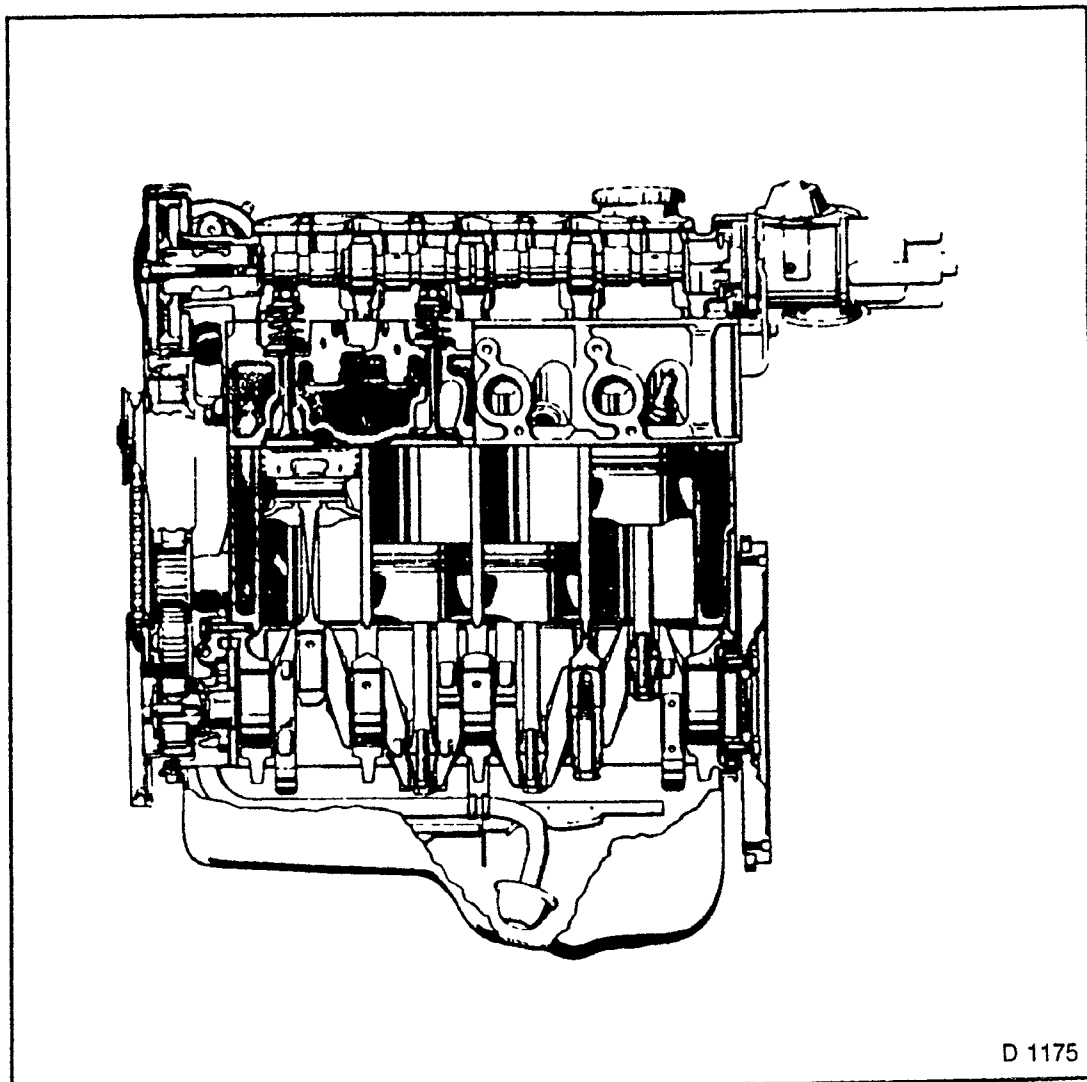


D 1176

Fig 1



14 NV  
Longitudinal Section

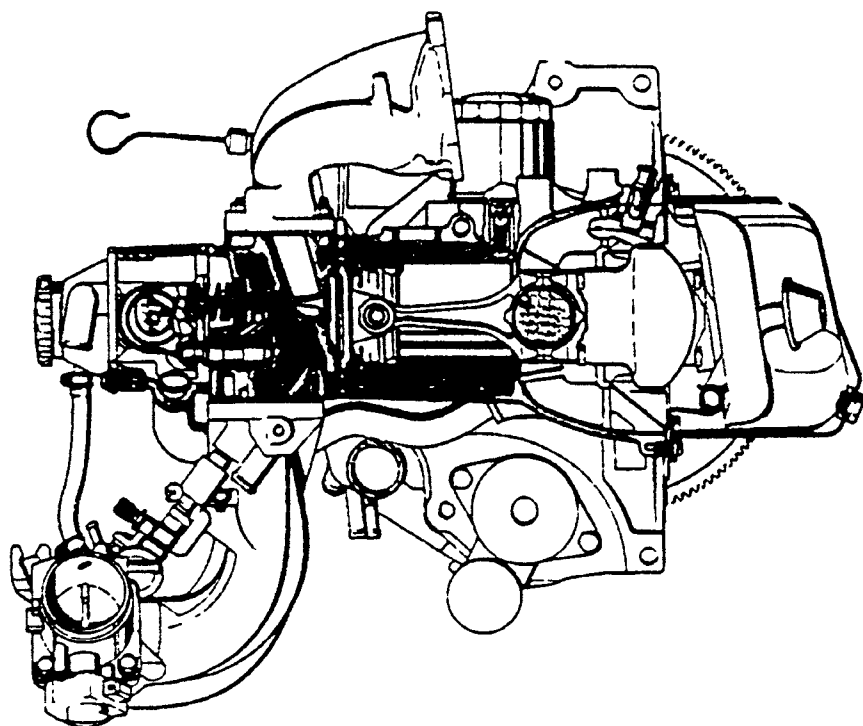


D 1175

Fig 2

C 16 SE

Cross Section



D 5887

Engine Timing

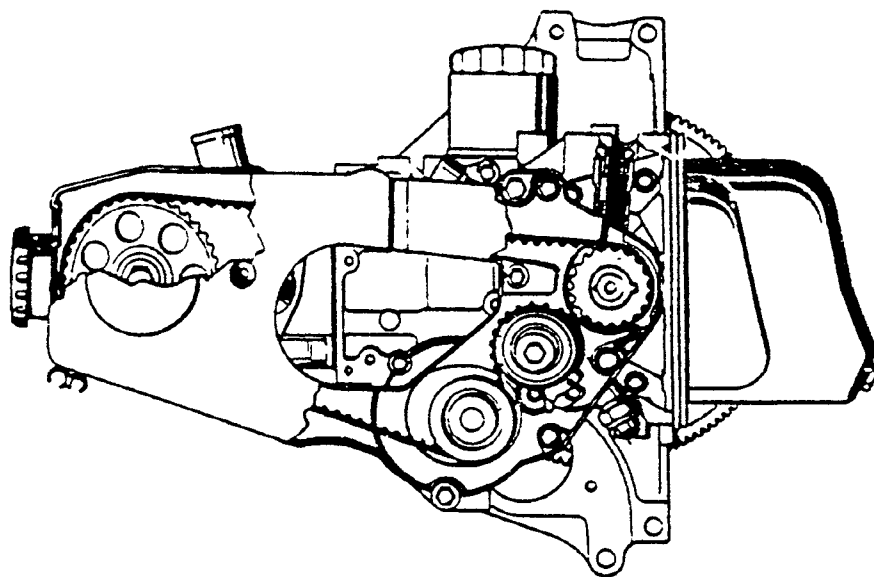


Fig 3

C 16 SE  
Longitudinal Section

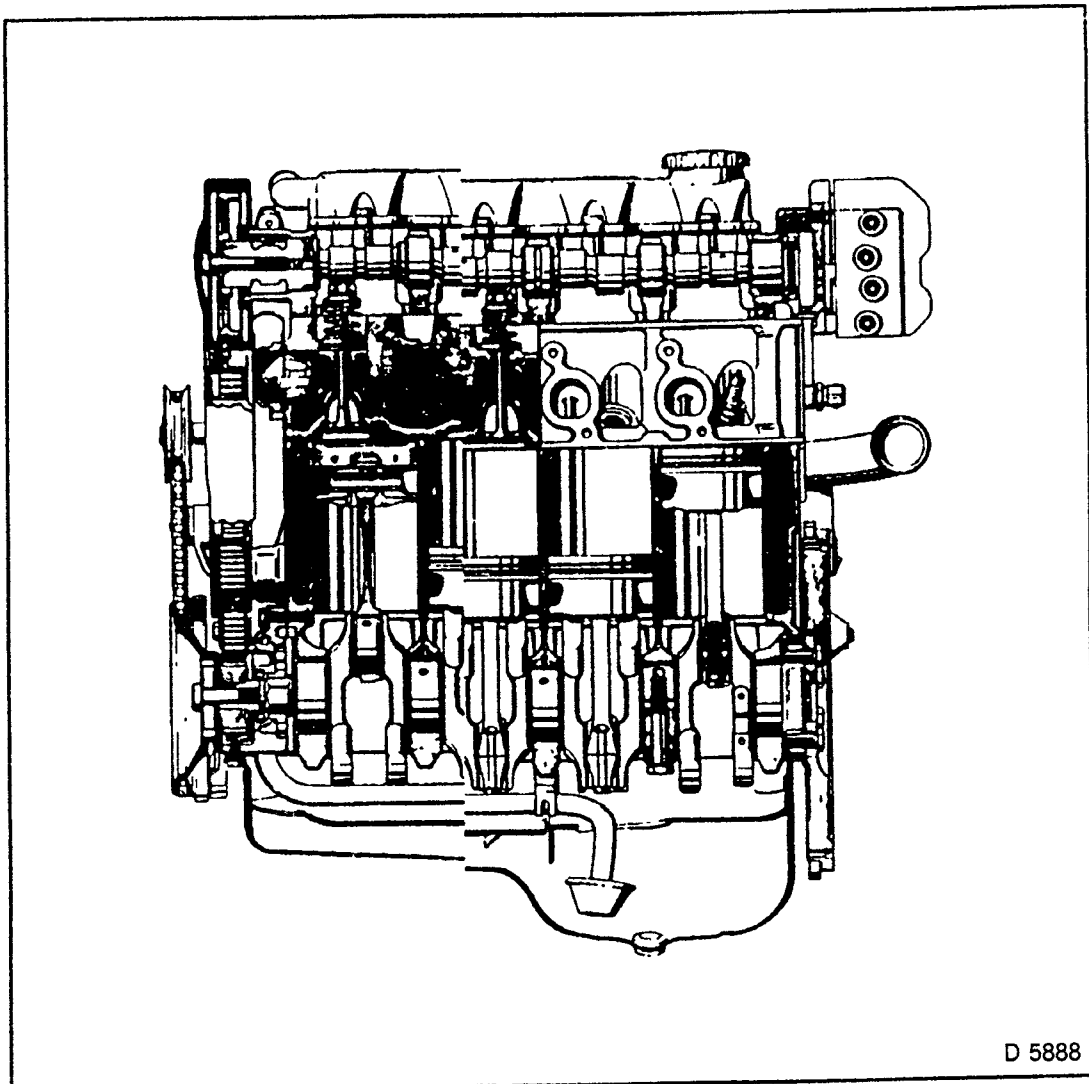
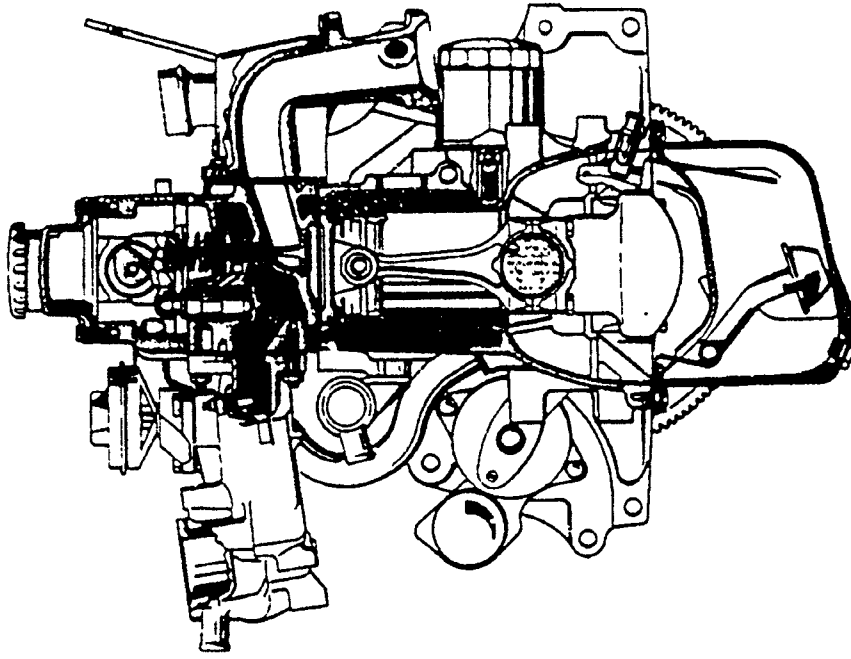


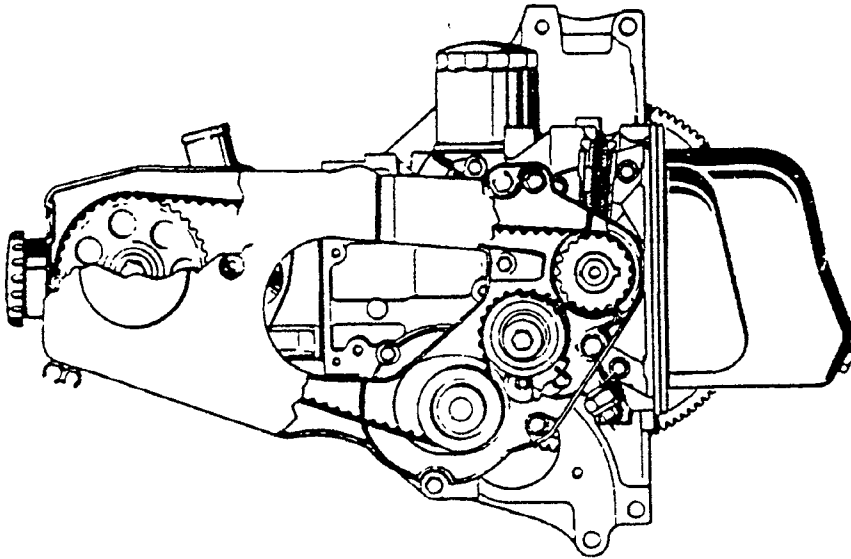
Fig 4

C 16 NZ

Cross Section



Engine Timing



D 1178

Fig 5

C 16 NZ  
Longitudinal Section

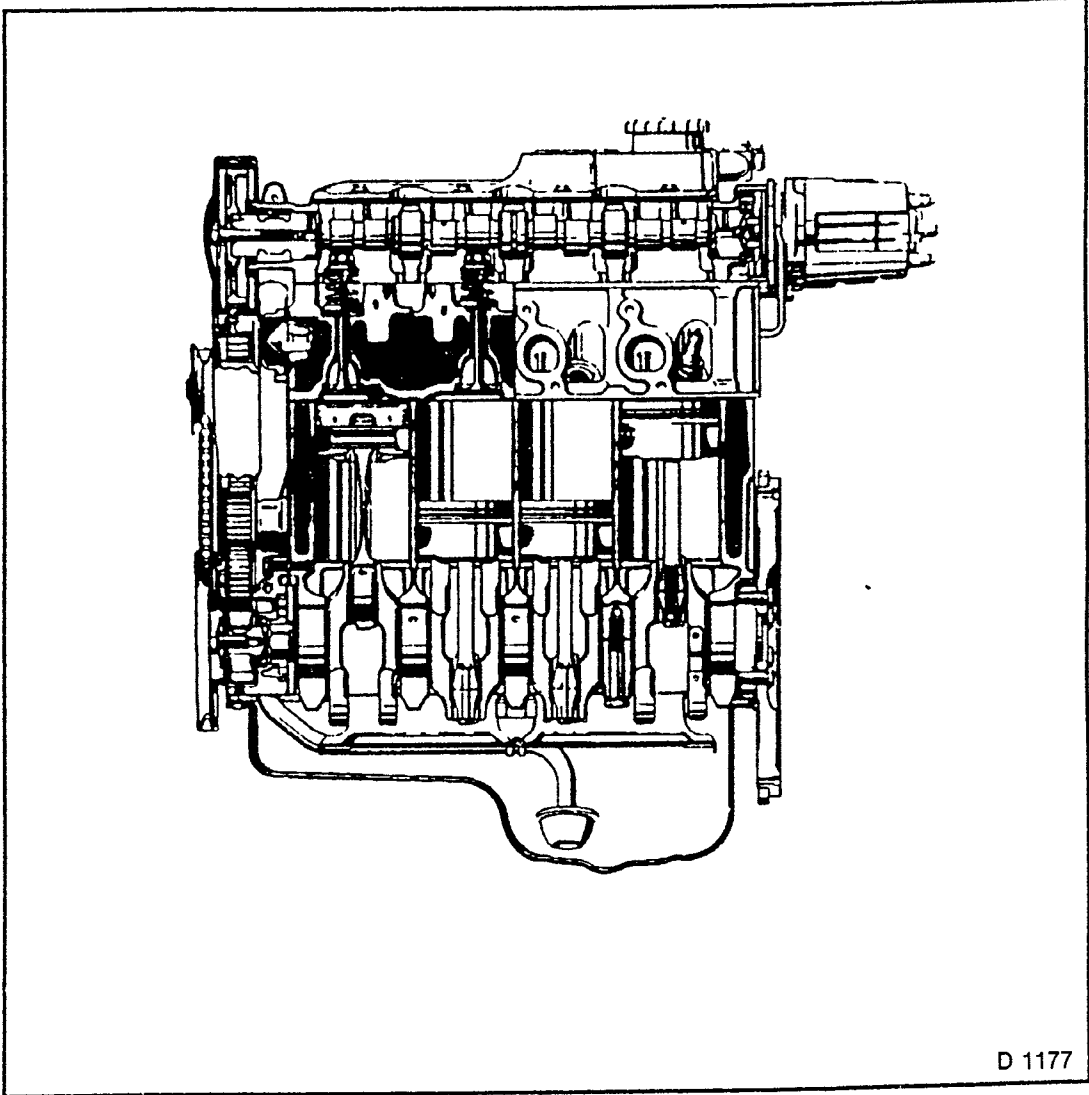


Fig 6

# ENGINE CHECKING AND ADJUSTING OPERATIONS

## Recommended Torque Values

	Nm
Alternator bracket to cylinder block (M 10) .....	40
Alternator to bracket (M 10) .....	35 <sup>2)</sup>
Alternator to bracket (M 8) .....	30
Oil filter cartridge to connection fitting (cylinder block) .....	15 <sup>1)</sup>
Oil filter cartridge to oil pump .....	15 <sup>2)</sup>
Oil pressure switch/sensor to oil pump .....	30 <sup>1)</sup>
Oil pressure switch/sensor to oil pump .....	40 <sup>2)</sup>
Retaining strap to alternator .....	25
Spark plugs to cylinder head .....	25
Water pump to cylinder block (M 6) .....	8 <sup>1)</sup>
Water pump to cylinder block (M 8) .....	25 <sup>2)</sup>

<sup>1)</sup> 1,4/1,6 ltr. engine

<sup>2)</sup> 1,8/2,0 ltr engine

## V-Belt Tension — Check and Adjust

(except 1,6 ltr. with power steering)

### REMOVE, DISCONNECT

1. If present: air intake hose.

### MEASURE

1. V-belt tension — KM-128-A.
2. 450 N (new V-belt)
3. 250 to 300 N (used V-belt)
4. Press Lever "A", until pin touches V-belt and a buzzing tone is audible.
5. Multiply value by 100, corresponds to V-belt tension in N.

### INSTALL, CONNECT

1. Air intake hose.

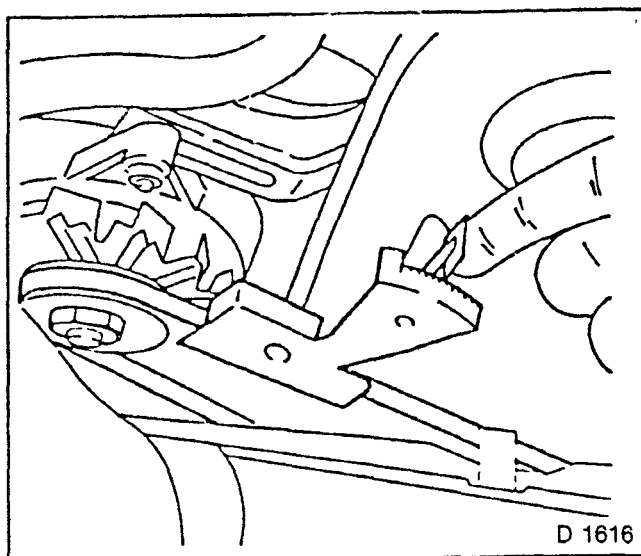


Fig. 7

### ADJUST

1. V-belt tension.
2. Loosen clamping bracket.
3. Lower alternator fastening.
4. Push alternator.

### TIGHTEN (TORQUE)

1. Clamping bracket to alternator — 25 Nm.
2. Lower alternator fastening (M8) — 30 Nm.
3. Lower alternator fastening (M10) — \*40 Nm.

\*With 1,8 and 2,0 ltr. engines — 35 Nm.

## Ribbed V-belt Tension — Check and Adjust

(16SE with Air-conditioning).

### REMOVE, DISCONNECT

1. Air intake hose.
2. Loosen clamping bracket.
3. Lower alternator bracket.

### ADJUST

1. Ribbed V-belt tension — KM-612 and torque wrench.
  2. New ribbed V-belt: 400 to 430 N equals 55 Nm.\*
  3. Used ribbed V-belt: 350 N equals 50 Nm.\*
- \*Display on torque wrench.

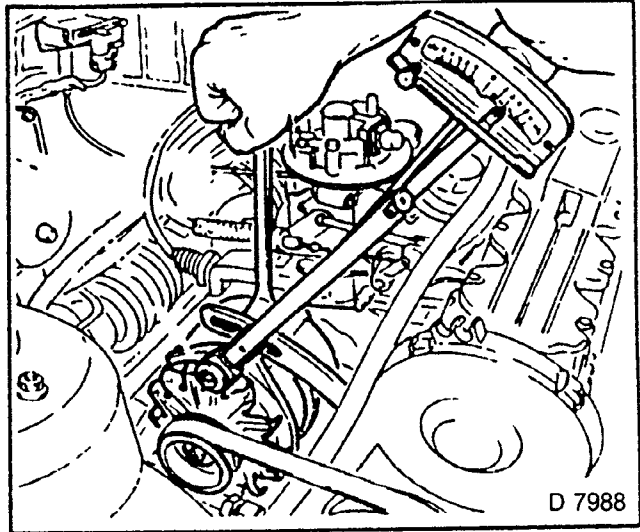


Fig. 8

### TIGHTEN (TORQUE)

1. Clamping bracket to alternator — 25 Nm.
2. Lower alternator bracket (M8) — 30 Nm.
3. Lower alternator bracket (M10) — 35 Nm.

### INSTALL, CONNECT

1. Air intake hose.

## Compression — Check

Engine at operating temperature (oil temperature  $\geq 80$  °C/176 °F).

### REMOVE, DISCONNECT

1. All spark plugs.
2. With injection engines, wiring plug (1) from fuel pump relay. Installation position of fuel pump relay — see section N.
3. Terminal "15" or wiring plug (2) from ignition coil.

### NOTE:

Use compression recorder with rubber cone and measuring range to 1750 kPa (17.5 bar/253.75 psi).

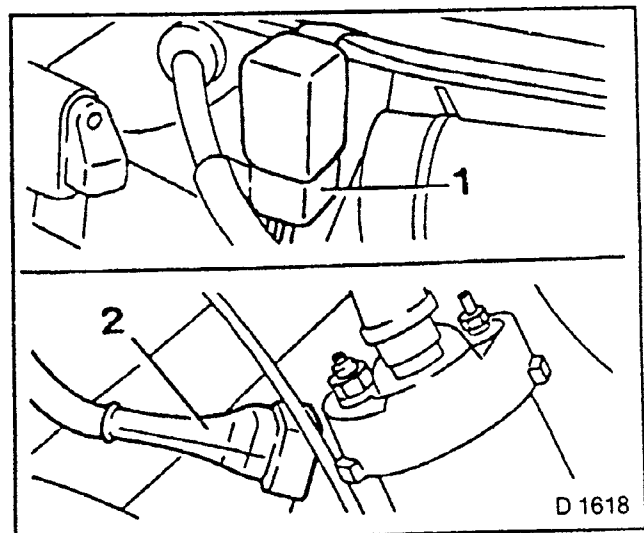


Fig 9



**INSPECT**

1. Compression.
2. Operate starter approximately four seconds with fully opened throttle valve — minimum engine speed approximately 300 rpm.
3. Permissible pressure deviation of individual cylinders approximately 100 kPa (1 bar/17.5 psi).

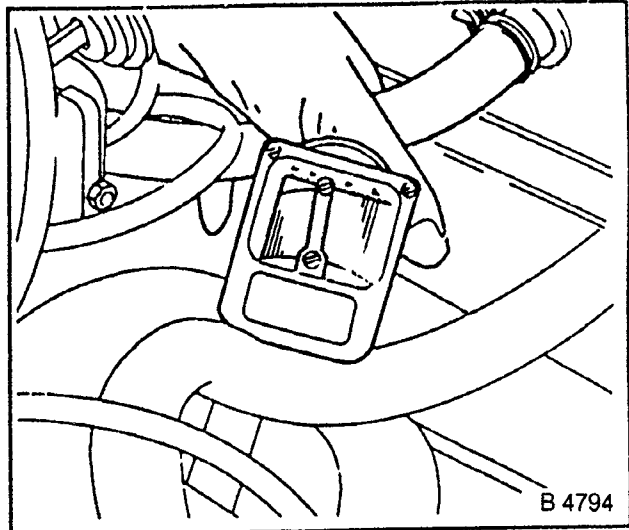


Fig. 10

**TIGHTEN (TORQUE)**

1. Spark plugs in cylinder head — 25 Nm.

**INSTALL, CONNECT**

1. Wiring plug (1) to fuel pump relay.
2. Wiring plug (2) or terminal "15" to ignition coil.

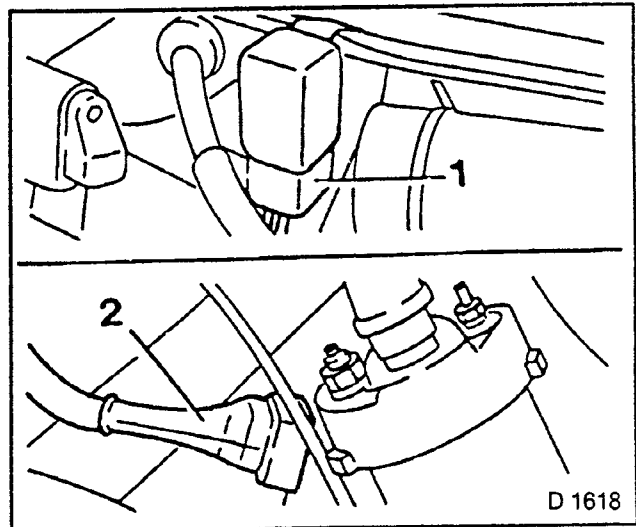


Fig. 11

## Engine Pressure Loss — Check

Engine at operating temperature  
(oil temperature —  $\geq 80^{\circ}\text{C}/176^{\circ}\text{F}$ ).

### REMOVE, DISCONNECT

1. All spark plugs.
2. Air cleaner.
3. Oil filler opening cover.
4. Coolant compensation tank cover.
5. Oil dipstick.
6. If present:
  - Air intake hose.
  - Pre-volume chamber.

### ADJUST

1. Piston of 1st cylinder at TDC position — markings.  
Determine TDC position — see operation.  
“Timing, Check and Adjust” — page 15.

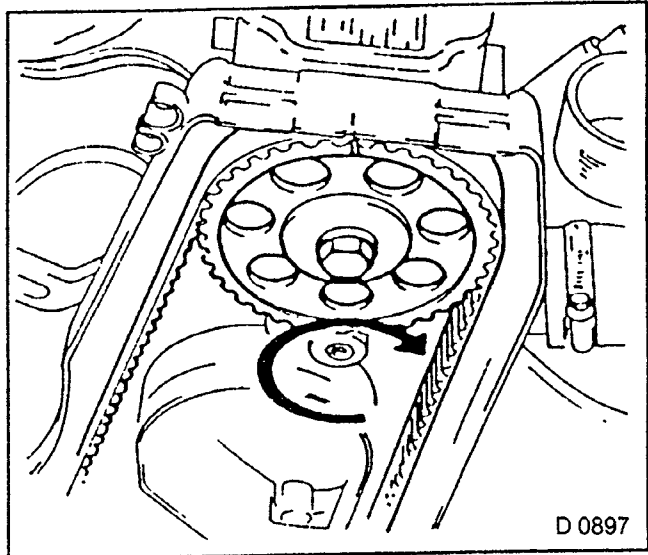


Fig 12

### INSTALL, CONNECT

1. Connecting piece to spark plug bore of 1st cylinder.
2. Compression loss tester to compressed air system.
3. Connecting hose to connecting piece (observe manufacturer's instructions).

### NOTE:

When checking, the crankshaft must **not** turn. Disconnect tester, correct crankshaft position and reconnect connection hose.

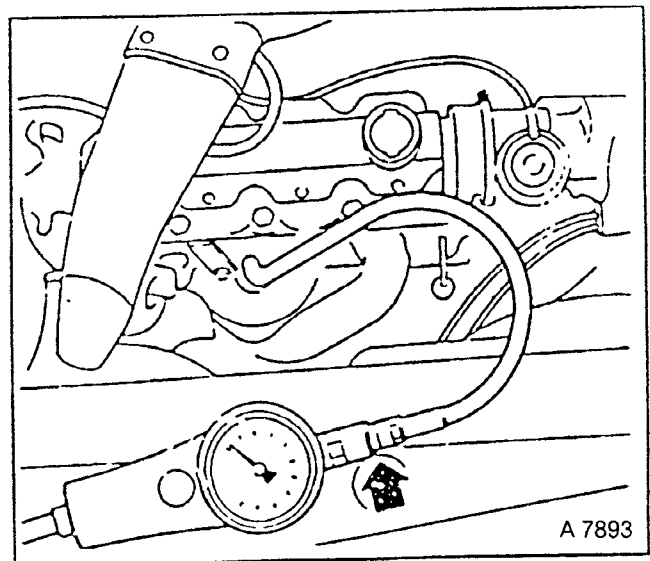


Fig. 13

### INSPECT

1. Compression loss.
2. Permitted total compression loss per cylinder approximately 25%.
3. Permitted compression deviation of individual cylinders approximately 10%.
4. Air flow to:
  - intake pipe
  - exhaust
  - compensation tank
  - crank housing.

**INSPECT**

1. Compression loss analogously with 3rd, 4th and 2nd cylinders.
2. Piston of cylinder to be checked in TDC position.  
Ignition sequence: 1-3-4-2
3. Ascertain TDC position by making marks on camshaft timing gear.
4. Turn camshaft timing gear a further 90° in direction of engine rotation (align marking on camshaft timing gear and toothed belt cover).
5. Ascertain TDC position for 4th and 2nd cylinder similarly.

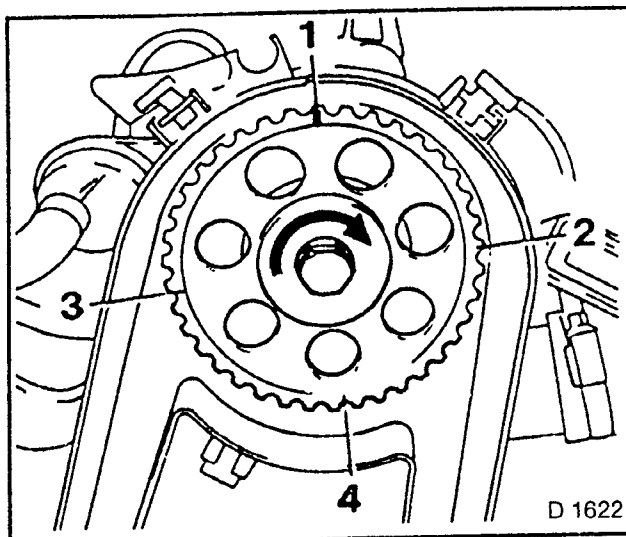


Fig. 14

**TIGHTEN (TORQUE)**

- 1 Spark plugs in cylinder head — 25 Nm.

**INSTALL, CONNECT**

1. Oil dipstick.
2. Cover.
3. Air cleaner.
4. If removed:  
Pre-volume chamber,  
— Air intake hose.

**Engine Oil Temperature — Measure****MEASURE**

- 1 Engine oil temperature — MKM-596.
2. Insert measuring probe into dipstick guide pipe to approximately 1 cm above oil pan floor
- 3 Seal the guide pipe opening with enclosed rubber plug.

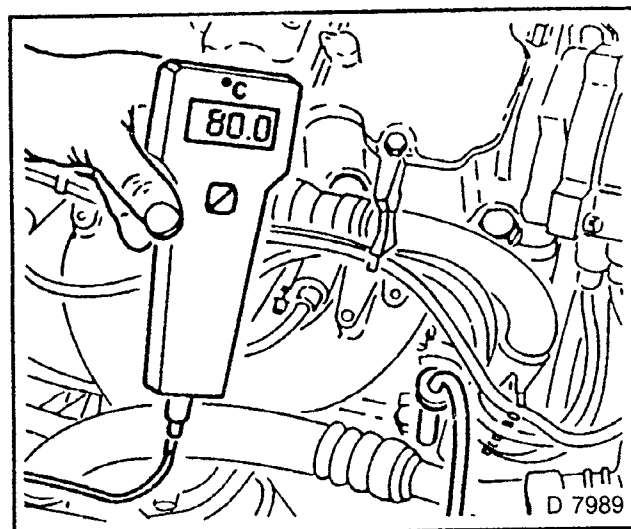


Fig. 15

## Engine Oil Pressure — Check

### REMOVE, DISCONNECT

1. Oil pressure switch/sensor.

### INSPECT

1. Oil pressure — KM-498-B (1) and KM-135 (2).
2. Oil pressure minimum 0.3 bar/4.5 psi at idle speed.
3. Oil temperature  $\geq 80^{\circ}\text{C}/176^{\circ}\text{F}$ .

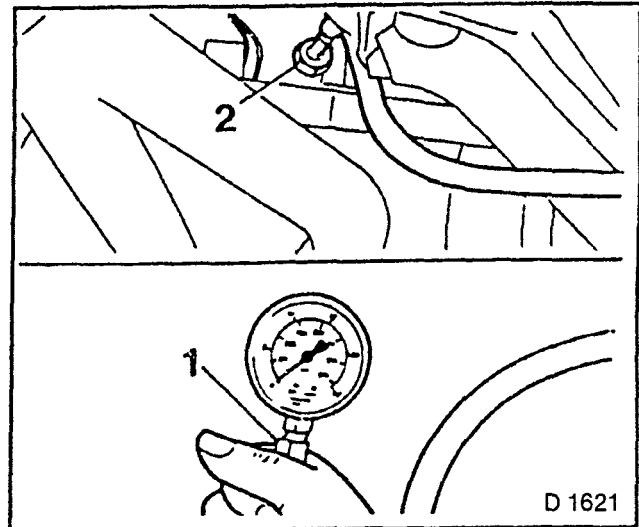


Fig. 16

### INSTALL, CONNECT

1. Oil pressure switch/sensor.

### TIGHTEN (TORQUE)

1. 1,4/1,6 Ltr: Oil pressure switch/sensor to oil pump — 30 Nm.
2. 1,8/2,0 Ltr: Oil pressure switch/sensor to oil pump — 40 Nm.

## Engine Oil Consumption — Measure

### GENERAL

The term “oil consumption” of an internal combustion engine refers to the amount of oil which is used as a result of combustion. Oil consumption should under no circumstances be confused with oil loss caused by leaks in the oil pan, cylinder head cover, etc.

The task of the engine oil is to:

1. Separate surfaces that slide on one another with an oil film, i.e. prevent dry friction.
2. Conduct the heat produced by friction away.
3. Conduct combustion residue away.

These tasks necessitate the consumption of a certain amount of oil.

The oil consumption is however influenced by external operating factors, driving style and manufacturing tolerances. Under normal circumstances, the consumption is so minimal that only a small amount need be topped up between the prescribed oil change intervals, or even no topping up at all. Topping up is however absolutely necessary if the oil level sinks below the “MIN” mark on the dipstick. Ensure that the oil level does not exceed the upper “MAX” mark on the dipstick, which leads to increased oil consumption.

As oil consumption is a technical necessity, indications that an engine is not consuming oil means that we can conclude that the oil is being diluted by special operating conditions. Frequent cold starts, driving when over-cold, etc. result in the oil flowing back to the oil pan containing fuel particles and condensation, and becomes “diluted”; this can lead to the incorrect supposition that the engine is not consuming any oil at all. Oil diluted in this fashion lacks lubricating power and may lead to engine damage if the prescribed oil change intervals are not observed. The main causes for oil dilution are driving in mainly urban traffic and frequent driving at too low engine speeds when the engine is cold.

The oil consumption first begins to stabilize after operating for a few thousand kilometers. Measurements of the oil consumption only become realistic after about 7 500 km. Before measuring the oil consumption, ensure that the engine is not losing oil due to a leak.

**NOTES:**

The oil dipstick can only be used for checking and not for measurement.

The engine must always be switched off for at least two minutes before the oil level can be checked.

If, after an oil change, the maximum engine oil filling does not match the maximum level mark on the dipstick, this can be attributed to manufacturing tolerances.

All information regarding filling quantities are included in the Owner's and Driver's Manual.

**MEASURING METHOD**

1. The check is carried out with the vehicle on a horizontal surface with the engine at operating temperature (engine oil temperature  $\geq 80^{\circ}\text{C}/176^{\circ}\text{F}$ ).
2. Allow engine to run at idle speed immediately before draining the engine oil.
3. Drain engine oil immediately after switching off engine and record the time with a stopwatch — draining time three minutes. (Experiments have indicated that the draining should be kept within three minutes). Always allow the engine oil to drain until the stream of oil turns into drops.
4. Allow the drained engine oil to cool down to approximately  $20^{\circ}\text{C}/68^{\circ}\text{F}$  (1 to 2 hours).
5. The amount of cooled oil determined in a measuring cylinder\* and fresh oil is added up to the maximum engine oil filling quantity, minus 0,25 litres for the unchanged engine oil filter.
6. Using this amount of engine oil, the customer should travel at least 500 km without changing the engine oil. (The driver should keep to his/her normal routes and driving style).
7. The procedure described above (points 1 to 4) is then repeated with exactly the same time for draining.
8. The amount of engine oil "missing" from the measuring cylinder is the engine oil consumption/distance covered.

\*Commercially available measuring cylinder (transparent) with a capacity of 1 to 2 litres.

## TIMING, CHECK AND ADJUST (1,4/1,6 LTR.)

### REMOVE, DISCONNECT

1. If necessary:
  - Air cleaner
  - Air intake hose.
2. Front toothed belt cover.
3. For split version, upper part of front toothed belt cover.
  
4. Turn crankshaft in direction of rotation of engine, until marks align.

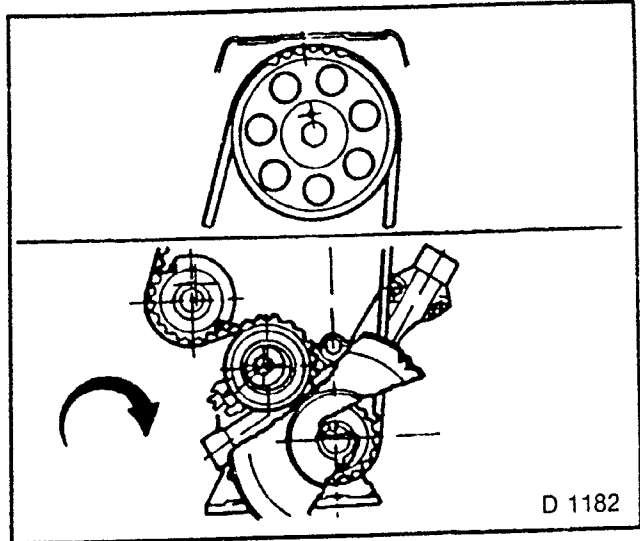


Fig. 17

### INSPECT

1. Cast in lower part of front toothed belt cover aligns with marking on crankshaft pulley.

**NOTE:**  
ON 14 NV ENGINES PLACE  
CRANKSHAFT PULLEY ON FIRST  
MARKING (10° BTDC).

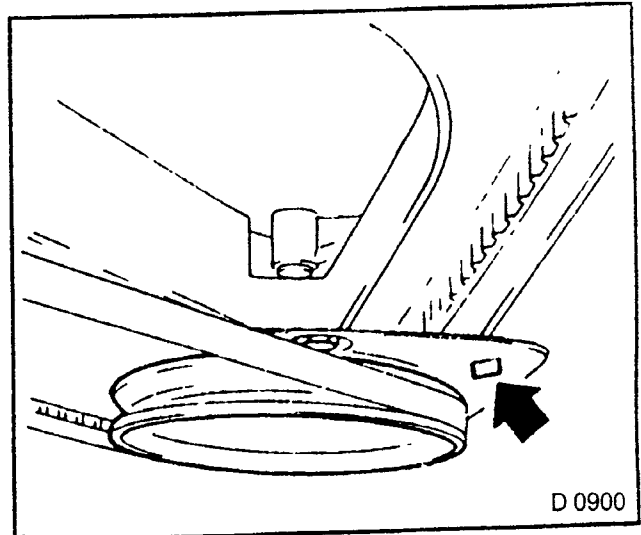


Fig 18

### INSPECT

- 1 On the 16 SE engines, TDC mark is on increment disc (in conjunction with ribbed V-belt pulley)

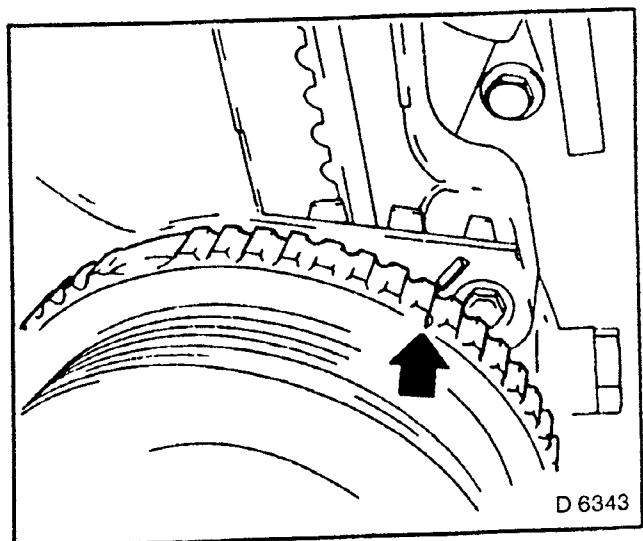


Fig. 19

**INSPECT**

1. On the 16 SE engine, TDC mark is on V-belt pulley (in conjunction with increment disc.)

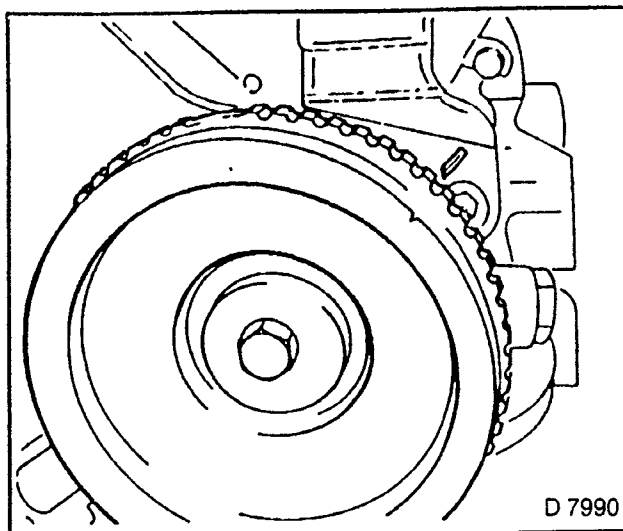


Fig 20

**INSPECT**

1. At the same time, the marks on the camshaft pulley and toothed belts cover must align.

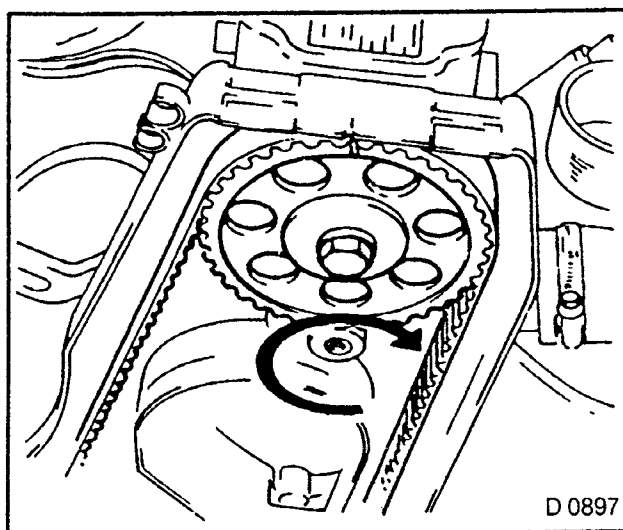


Fig 21

**ADJUST**

- 1 Timing.
2. Loosen water pump.
3. Remove toothed belt from camshaft timing gear.
4. Put camshaft timing gear (short distance) on marking.
5. Install and tension toothed belt.
6. Front toothed belt cover.
7. If removed:
  - Air intake hose.
  - Air cleaner.

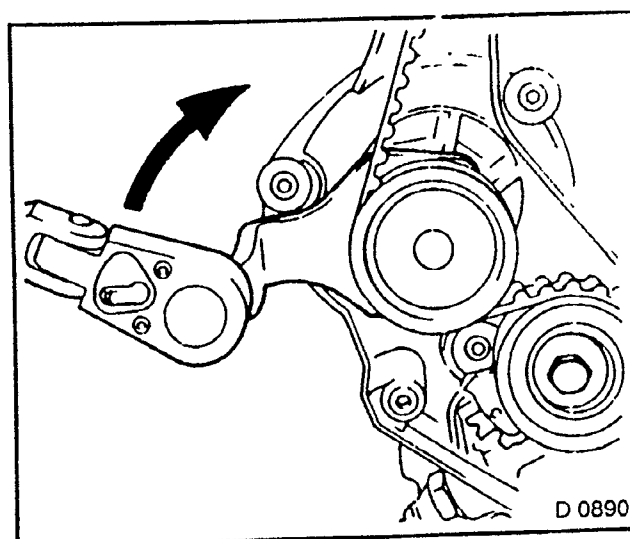


Fig. 22

## Timing — Check and Adjust (1,8/2,0 ltr.)

### REMOVE, DISCONNECT

1. If necessary:
  - Air cleaner.
  - Air intake hose.
2. Front toothed belt cover.

### INSPECT

1. Put crankshaft pulley notch on indicator in direction of engine rotation.
2. At the same time, the marks on the camshaft pulley and toothed belts cover must align.

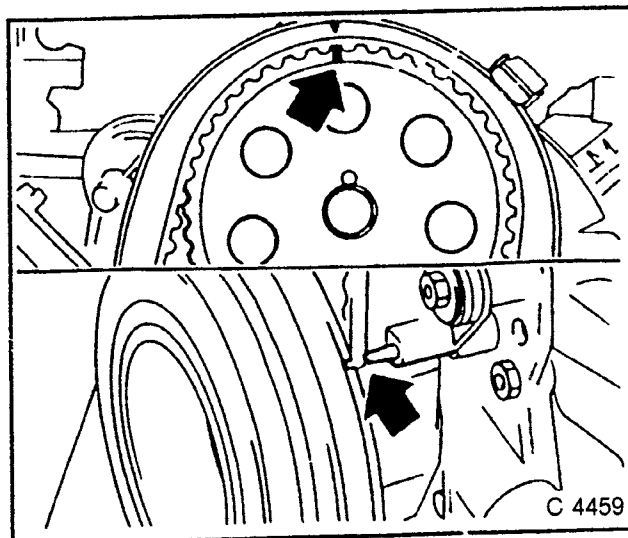


Fig 23

### ADJUST

1. Timing.
2. Loosen water pump, remove toothed belt from camshaft timing gear and put camshaft timing gear (short distance) on marking.
3. Install and tension toothed belt.

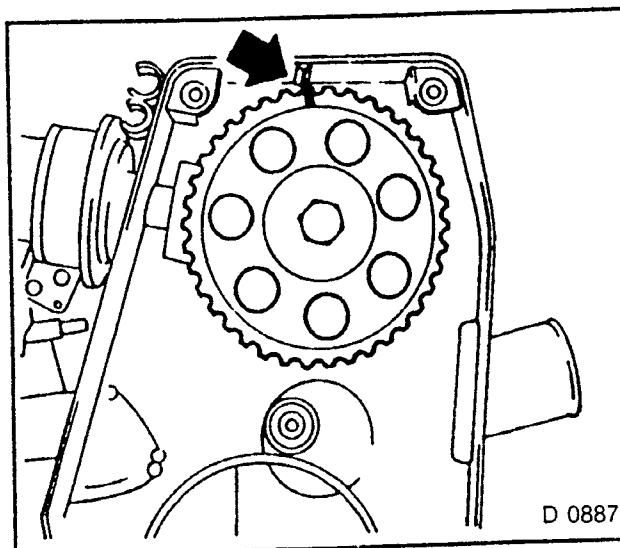


Fig. 24

### INSTALL, CONNECT

1. Front toothed belt cover.
2. If removed:
  - Air intake hose.
  - Air cleaner.



# Toothed Belt — Install and Tension (1,4/1,6/1,8/2,0 ltr. with Toothed Belt Tension Roller)

**NOTE:**  
ADJUSTMENT OF TOOTHED BELT IS CARRIED OUT ON COLD ENGINE.

## INSPECT

1. TDC position of 1st cylinder:
2. Marking on camshaft timing gear aligns with marking on toothed belt rear cover.

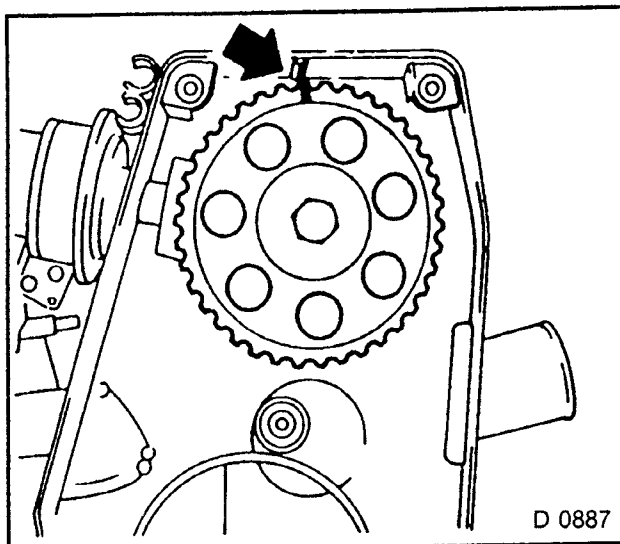


Fig. 25

## INSPECT

1. Punch marks on arrow on toothed belt drive gear (1) must align in the centre of the groove (2) on the oil pump housing or toothed belt cover in position illustrated.

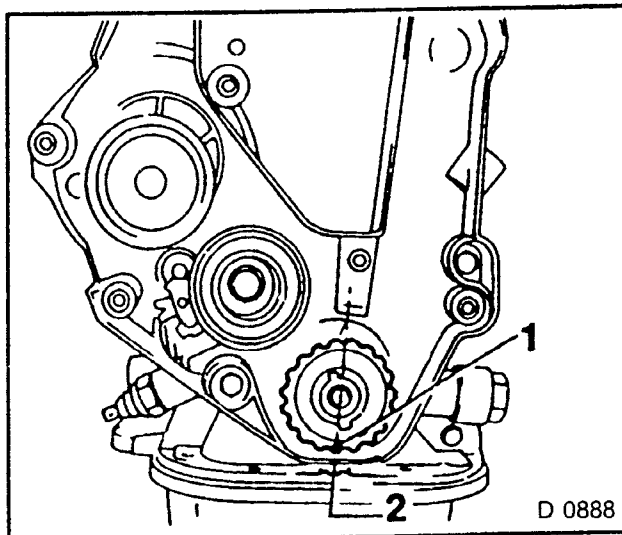


Fig. 26

2. Loosen fastening screws for water pump. Do not remove.

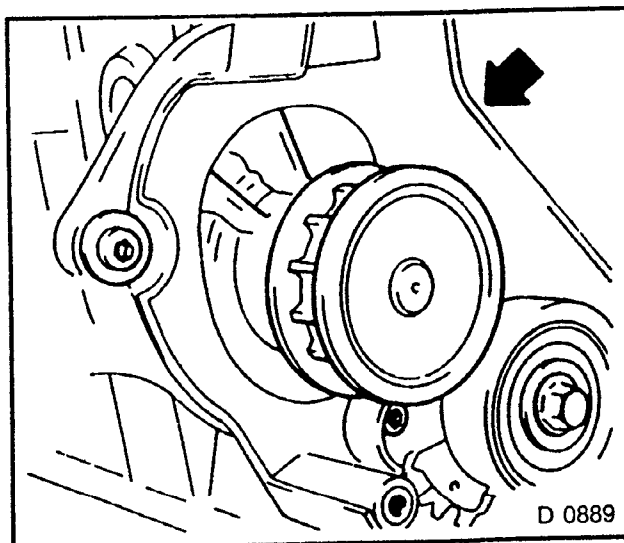


Fig. 27

3. Mount toothed belt

**NOTE:**  
**TENSIONED SIDE TAUT.**

**ADJUST**

1. Tighten toothed belt by turning water pump in direction illustrated using KM-421-A.

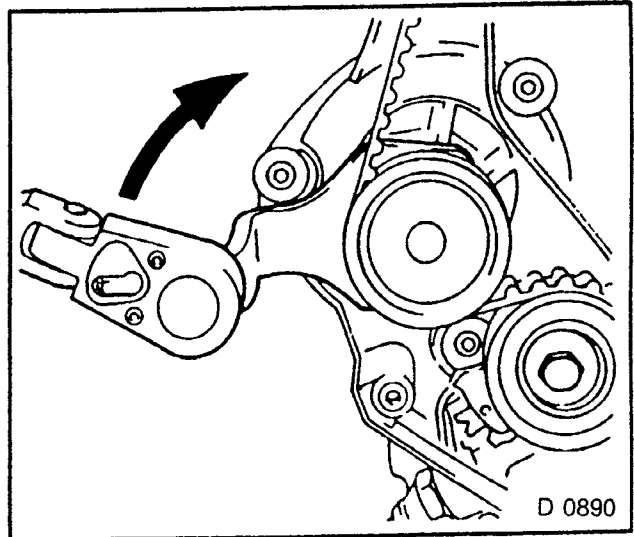


Fig. 28

**INSPECT**

1. Movable part (1) of tension roller (2) now has to be positioned at the right-hand stop.

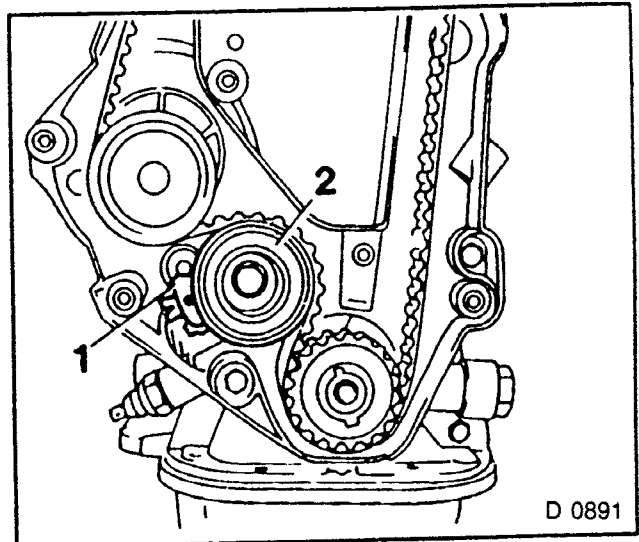


Fig. 29

2. Turn crankshaft in engine rotation direction (arrow) 720°, until camshaft timing gear and toothed belt drive gear are positioned on marking — 1st cylinder on TDC — again. For this use crankshaft pulley fastening screws.

**NOTE:**  
**TURN CRANKSHAFT JERK-FREE AND SMOOTHLY IN ORDER TO AVOID JUMPING OVER OF TOOTHED BELT. THE POSITION OF THE WATER PUMP MUST NOT BE ALTERED WHEN ROTATING THE ENGINE.**

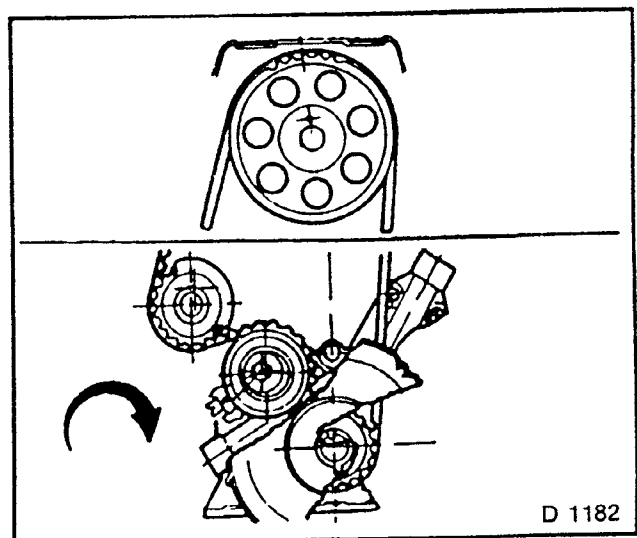


Fig. 30

**ADJUST**

1. Loosen toothed belt by turning water pump with KM-421-A in illustrated direction until indicator (1) and notch on tension roller support plate (2) align. See Fig. 31.

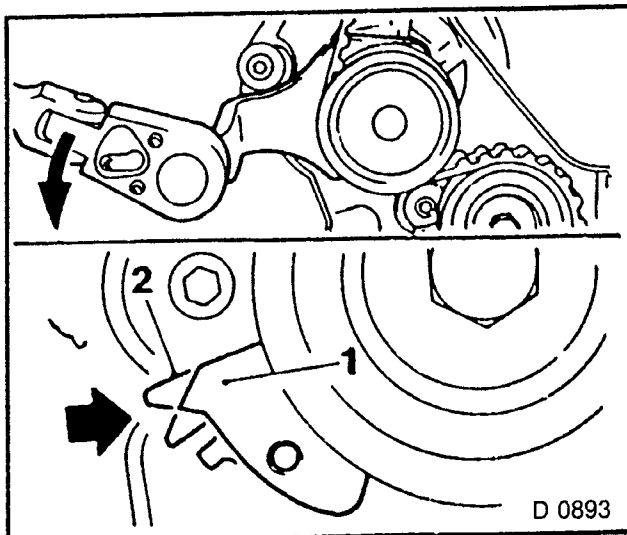


Fig. 31

**TIGHTEN (TORQUE)**

1. Water pump to cylinder block — 8 Nm (M6).

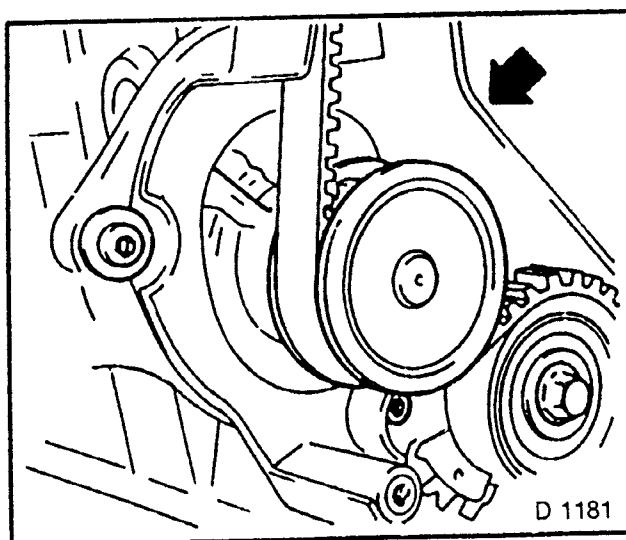


Fig. 32

**INSPECT**

1. Correct toothed belt tension has been achieved when the indicator on the movable part of the tension roller plate aligns with the tension roller support plate.

**NOTE:**  
IF THE INDICATOR POSITION SHOWN IN FIG. 33 IS NOT REACHED, THE ADJUSTING OPERATION MUST BE REPEATED.

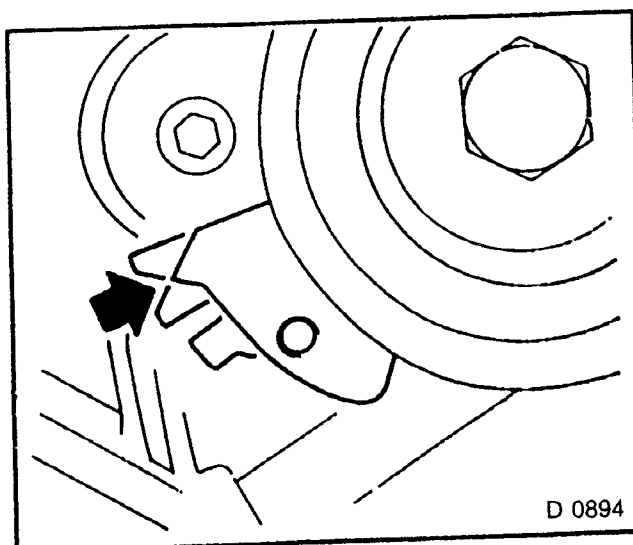


Fig. 33

## ENGINE TIMING SIDE

1,4/1,6 ltr.\*  
1,8/2,0 ltr.

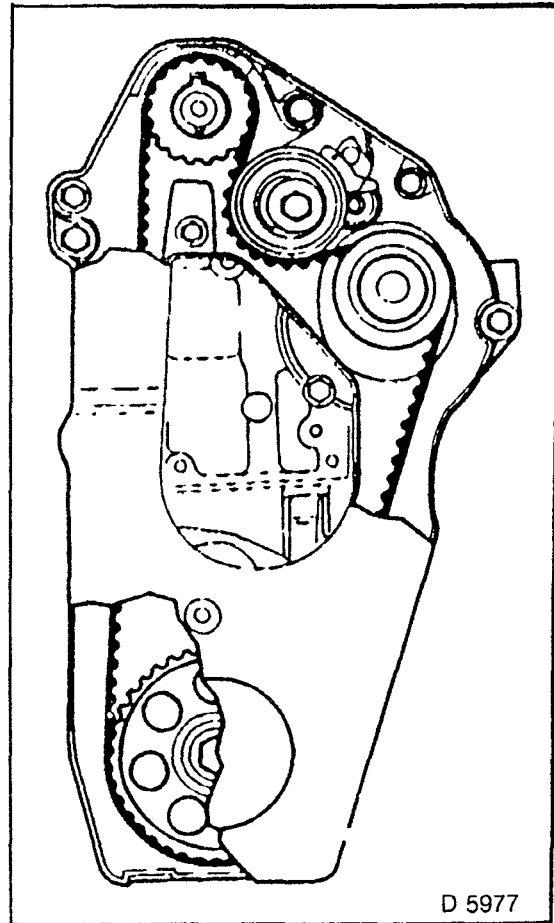


Fig. 34

\*Version with toothed belt tension roller.

## Recommended Torque Values

	Nm
Camshaft housing cover to housing .....	8
Camshaft sprocket to camshaft ... ..	45
Crankshaft pulley to toothed belt drive pinion .....	20 <sup>2)</sup>
Crankshaft pulley with toothed belt drive pinion to crankshaft (M10 — see position <sup>3)</sup> ) .....	95 + 30° + 15°
Crankshaft pulley with toothed belt drive pinion to crankshaft (M 12) .....	4 <sup>1)</sup>
Front toothed belt cover to rear toothed belt cover .....	25 <sup>4)</sup>
Pulley to pump for power steering .....	30 <sup>4)</sup>
Pump for power steering to engine block .....	6 <sup>2)</sup>
Rear toothed belt cover to camshaft housing and oil pump housing .....	12 <sup>1)</sup>
Rear toothed belt cover to camshaft housing and oil pump housing .....	20 <sup>1)</sup>
Toothed belt tension roller to oil pump .....	130 + 40° to 50° <sup>2)</sup>

<sup>1)</sup> 1,4/1,6 ltr. engine

<sup>2)</sup> 1,8/2,0 ltr. engine

<sup>3)</sup> Tighten bolt (thread length 23 mm) 20 00 560 (11 073 353) to 55 Nm.

Tighten bolt (thread length 30 mm) 6 14 938 (90 299 605) to 55 Nm + 45° + 15° (use new bolt).

<sup>4)</sup> 16SE only with Air-conditioning.

<sup>5)</sup> Use new bolts.

## Rear Toothed Belt Cover — Remove and Install (1,4/1,6/1,8/2,0 ltr. with Toothed Belt Tension Roller)

### REMOVE, DISCONNECT

1. Toothed belt — see operation "Toothed Belt, Replace".  
Camshaft housing cover, camshaft timing gear.

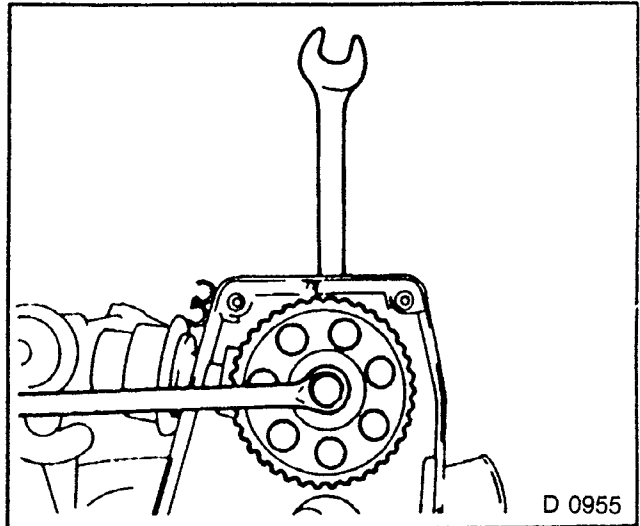


Fig 35

### REMOVE, DISCONNECT

1. Toothed belt tension roller.
2. Toothed belt drive gear.
3. Rear toothed belt cover.

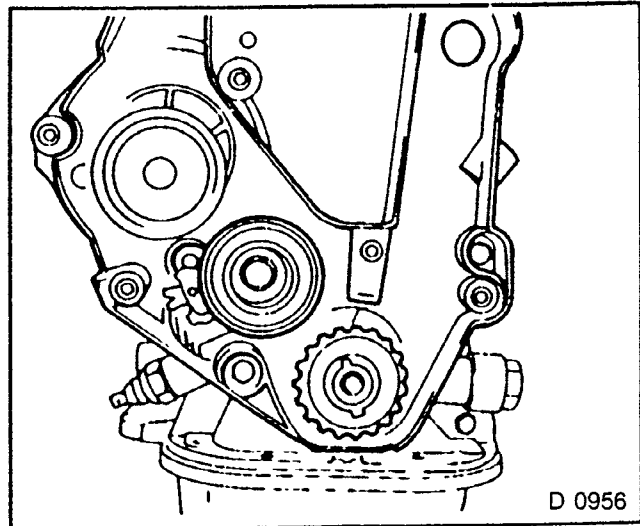


Fig. 36

### TIGHTEN (TORQUE)

1. Rear toothed belt cover to oil pump housing and camshaft housing — 12 Nm.
2. Push toothed belt drive gear onto crankshaft journal — note installation position.

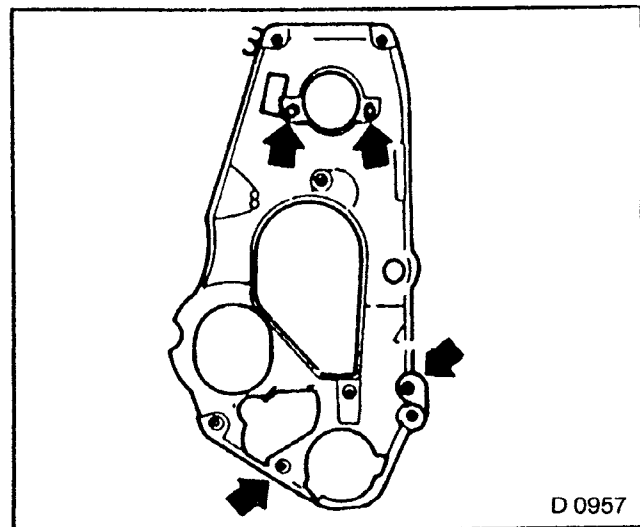


Fig. 37

**INSTALL, CONNECT**

1. Toothed belt tension roller.

**NOTE:**  
**NOTE INSTALLATION POSITION.**  
**INSERT TONGUE (1) OF TENSION**  
**ROLLER SUPPORT PLATE INTO**  
**BORE (2) OF OIL PUMP HOUSING.**

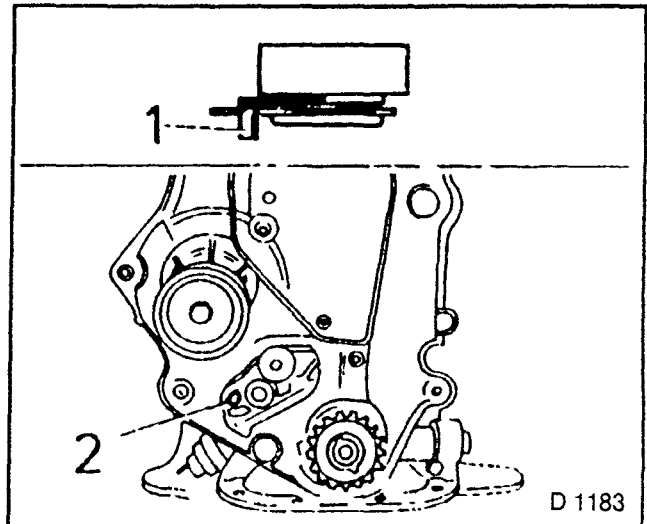


Fig. 38

**TIGHTEN (TORQUE)**

1. Toothed belt tension roller to oil pump — 20 Nm.

**NOTE:**  
**TURN TONGUE (1) OF TENSION**  
**ROLLER SUPPORT PLATE TO STOP**  
**ON OIL PUMP (2) BEFORE**  
**TIGHTENING TENSION ROLLER.**

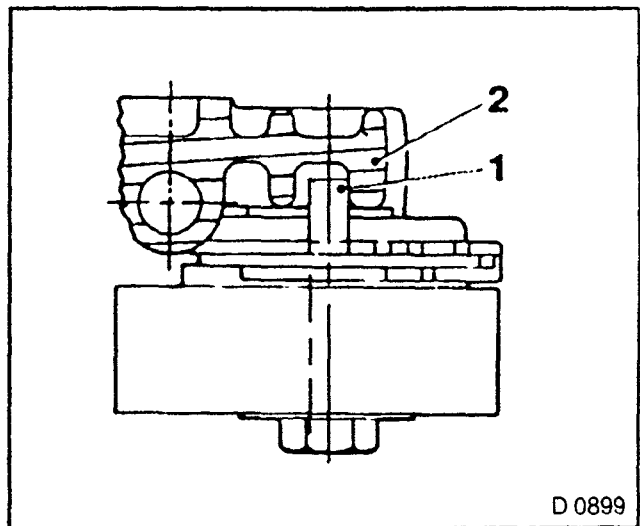


Fig. 39

**TIGHTEN (TORQUE)**

1. Camshaft timing gear to camshaft — 45 Nm.
2. Camshaft housing cover to housing — 8 Nm.
3. Install toothed belt — see operation "Toothed Belt, Replace".

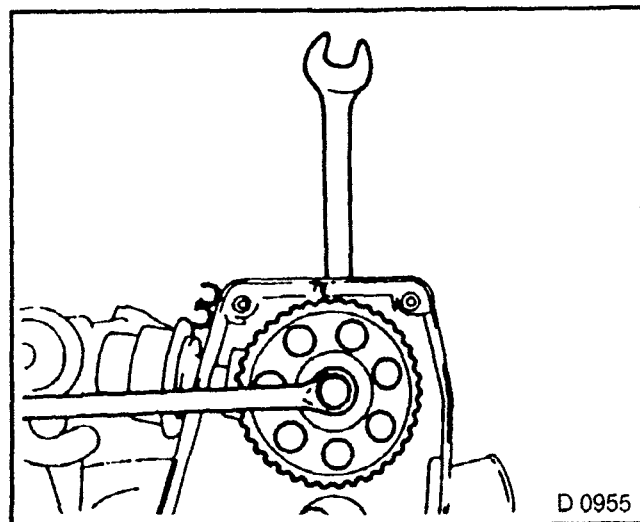


Fig. 40

## Toothed Belt — Replace (1,4/1,6 ltr. with Toothed Belt Tension Roller)

### REMOVE, DISCONNECT

1. Ground lead from battery.
2. Air cleaner.
3. Air intake hose.

### REMOVE, DISCONNECT

1. Clutch cover plate.
2. Crankshaft pulley — counterhold with KM-517 on flywheel.
3. Lower part of toothed belt front cover.

### REMOVE, DISCONNECT

1. Toothed belt from toothed belt tensioner.  
To do this, turn toothed belt tensioner in clockwise direction until bores coincide.
2. Tighten toothed belt tensioner.
3. Remove toothed belt.

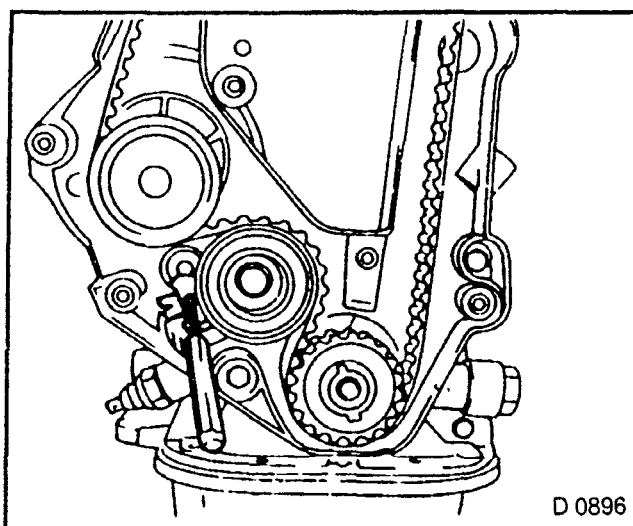


Fig 41

### ADJUST

1. Toothed belt tension.  
See operation "Toothed Belt, Insert and Tension". Page 18.

### TIGHTEN (TORQUE)

1. Front toothed belt cover to rear toothed belt cover — 4 Nm.
2. Crankshaft pulley with toothed belt drive gear to crankshaft — see "Recommended Torque Values", page 21.

#### **NOTE: WHEN INSTALLING CRANKSHAFT PULLEY, COUNTERHOLD WITH KM-517.**

3. Install clutch cover plate.
4. After installation of the crankshaft pulley in the C 16 SE engine, check the distance between the inductive pulse pick-up and the increment disc.

## Toothed Belt Tension Roller — Replace (1,4/1,6 ltr.)

### REMOVE, DISCONNECT

- 1 Toothed belt — see “Toothed Belt, Replace”.
2. Toothed belt tension roller.

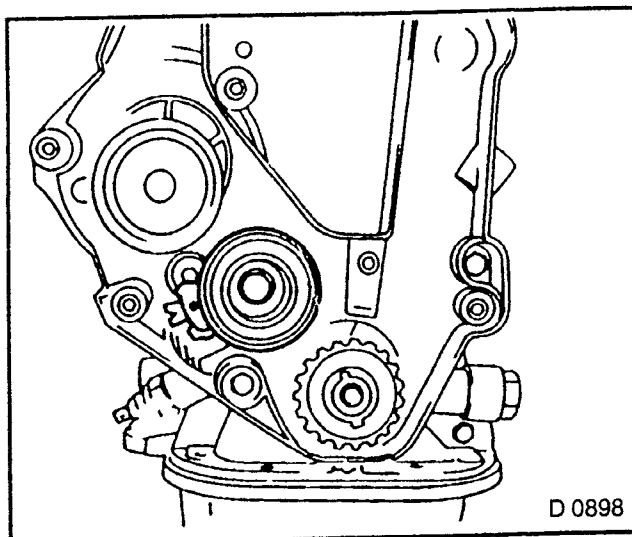


Fig. 42

3. Insert toothed belt tension roller.

**NOTE:**  
NOTE INSTALLATION POSITION.  
INSERT TONGUE (1) OF TENSIONER  
SUPPORT PLATE IN BORE (2) OF OIL  
PUMP HOUSING.

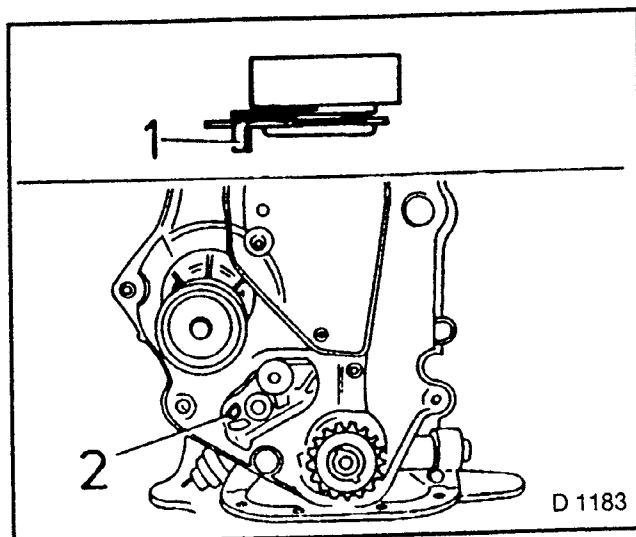


Fig. 43

### TIGHTEN (TORQUE)

1. Toothed belt tension roller to oil pump — 20 Nm.

**NOTE:**  
TURN TONGUE (1) OF TENSION  
ROLLER SUPPORT PLATE TO STOP  
ON OIL PUMP (2) BEFORE  
TIGHTENING TENSION ROLLER.

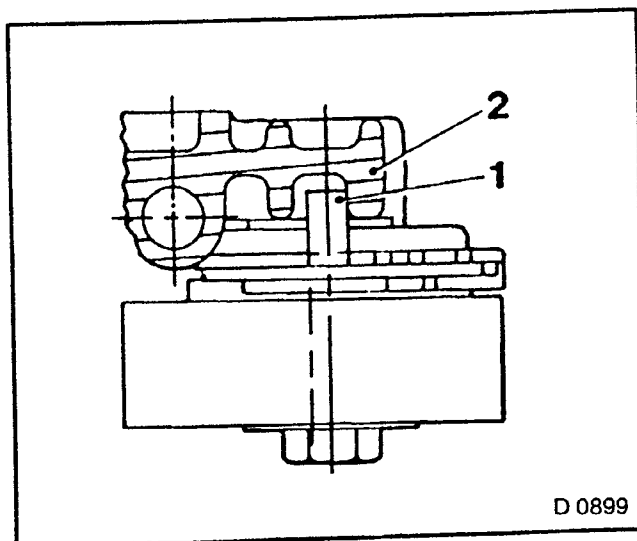


Fig. 44



**INSTALL, CONNECT**

1. Toothed belt — see operation “Toothed Belt, Replace”. Page 24.

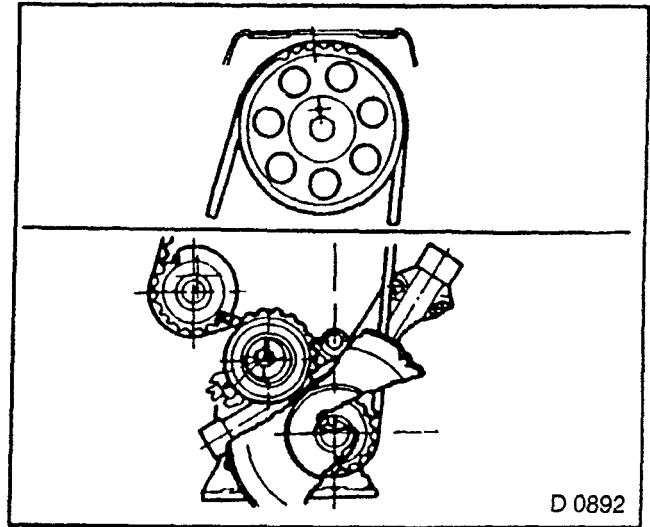
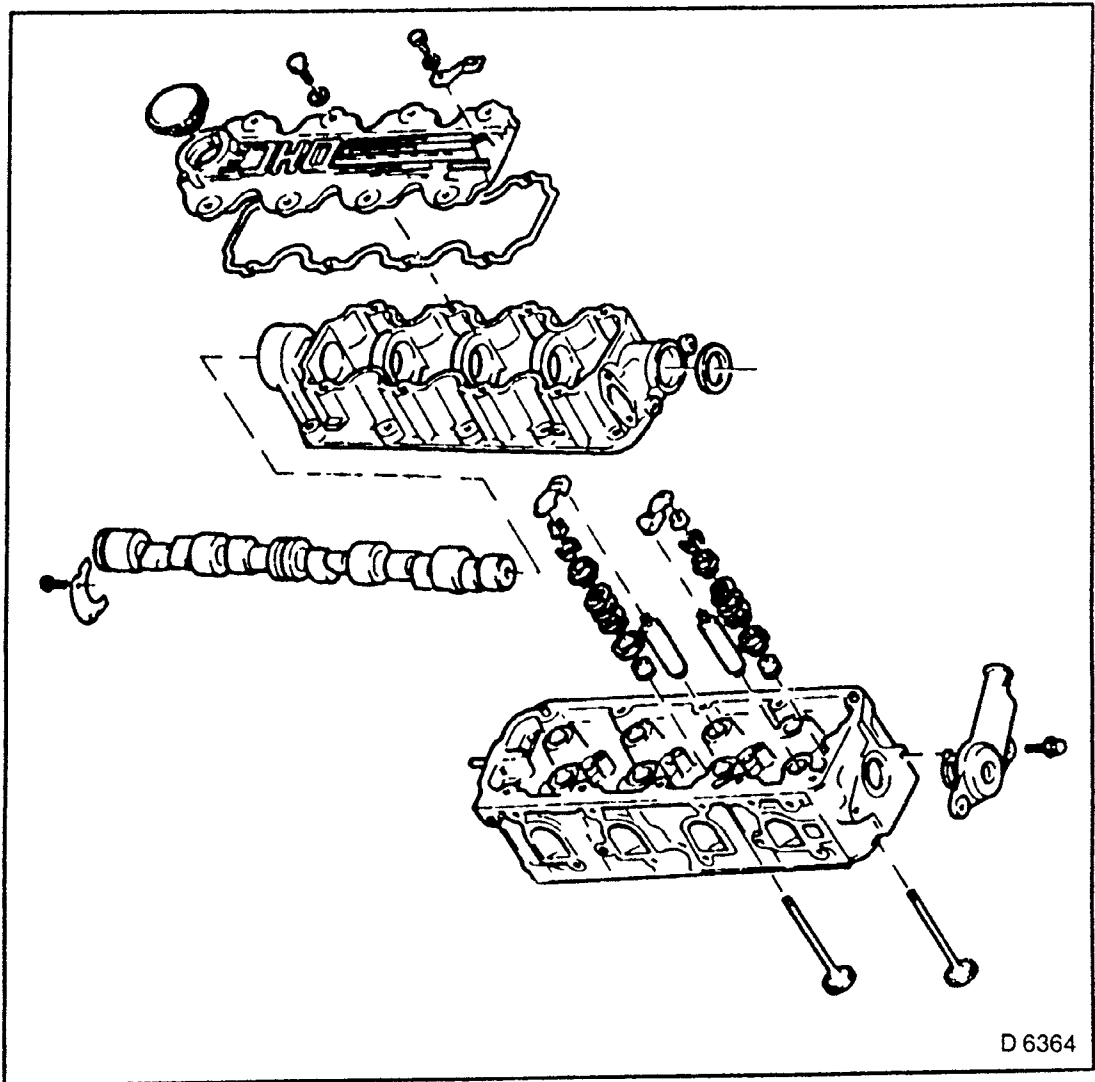


Fig. 45

CYLINDER HEAD, CAMSHAFT HOUSING

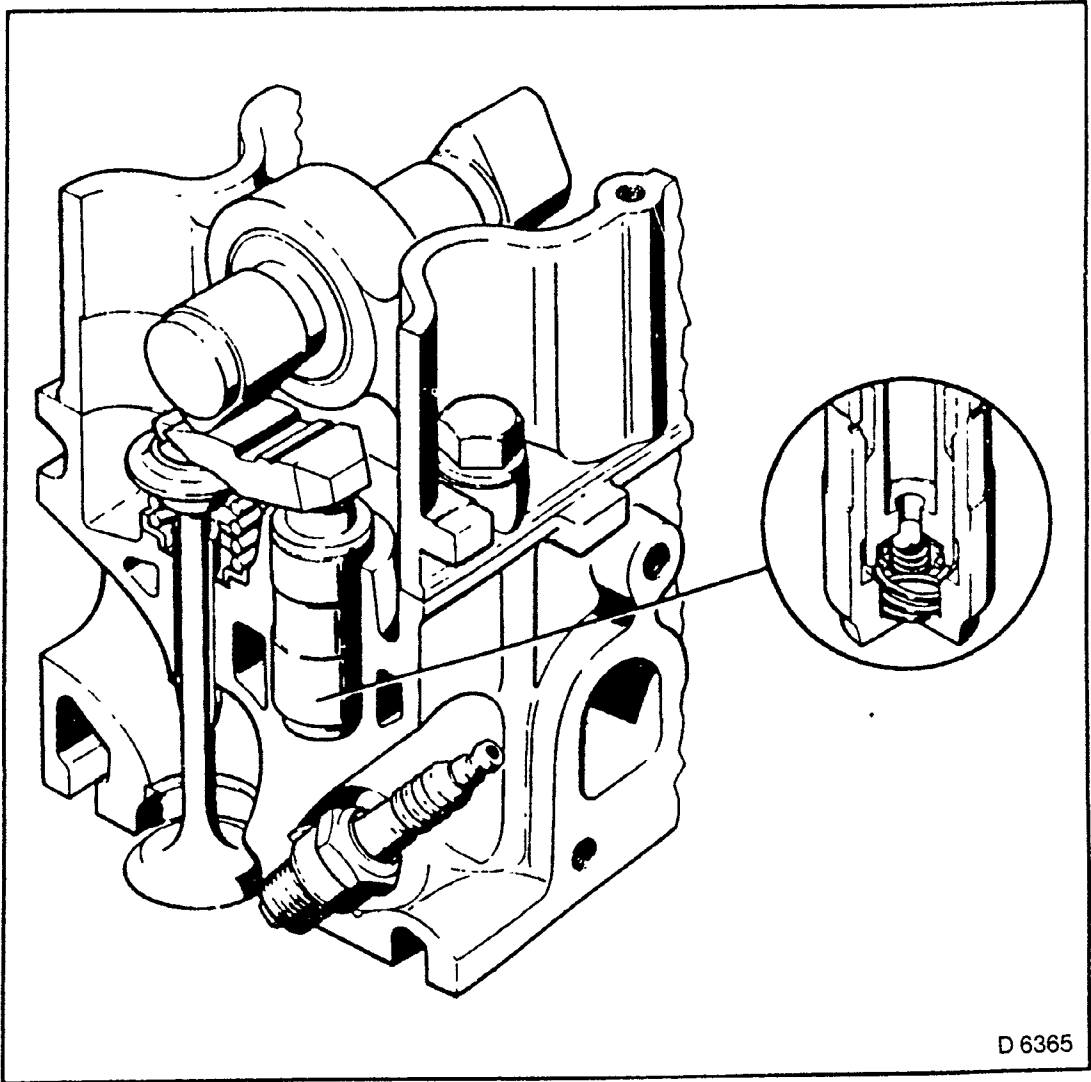
1,4/1,6 ltr



D 6364

Fig. 46

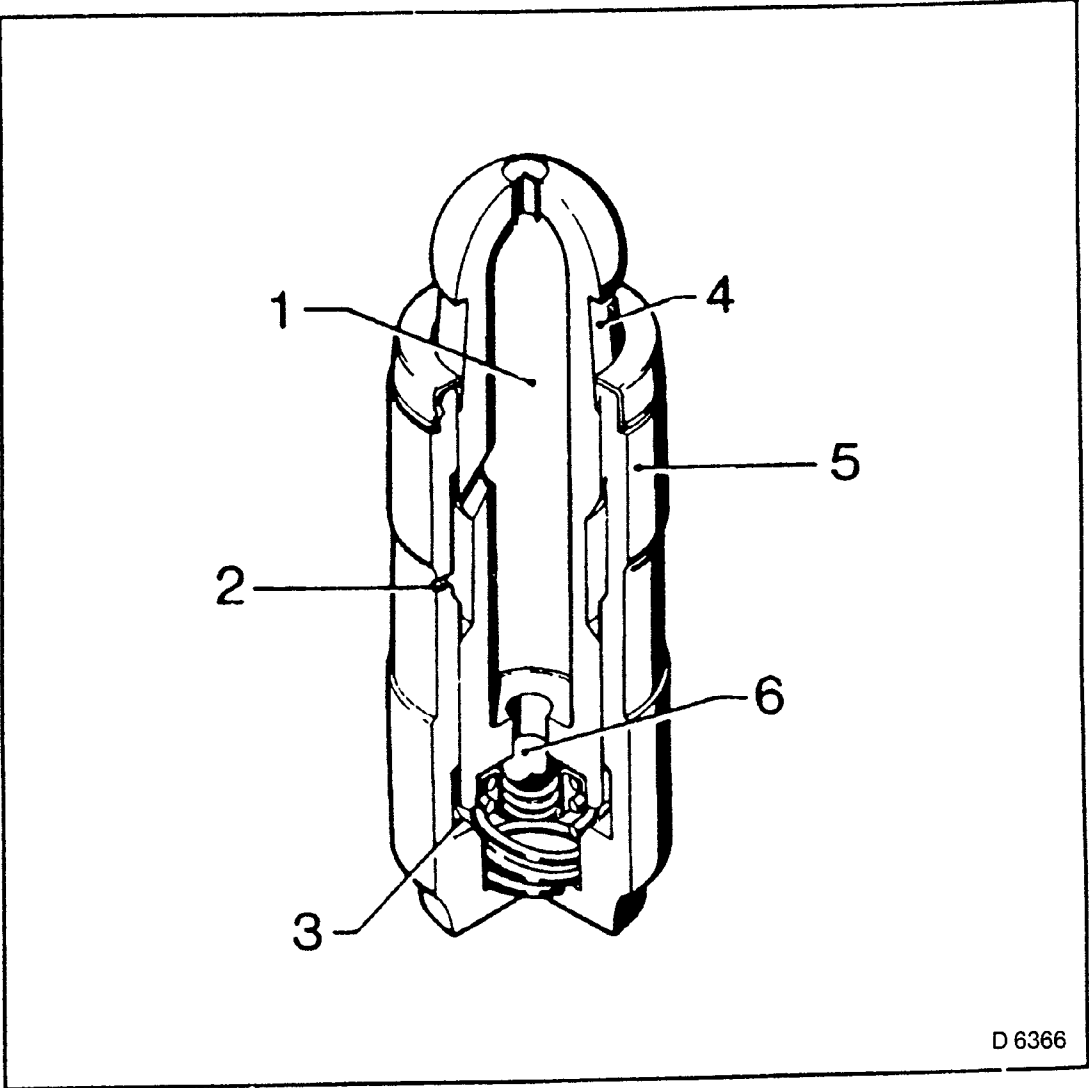
Hydraulic valve lash adjustment



D 6365

Fig. 47

Hydraulic valve tappet



D 6366

Fig. 48

- 1. Oil reservoir.
- 2. Oil feed.
- 3. Pressure chamber.
- 4. Piston with ball end (moveable).
- 5. Pressure cylinder (fixed).
- 6. Closure ball.

## Recommended Torque Values

	Nm
Camshaft housing cover to housing .....	8
Camshaft pressure plate to camshaft housing .....	8
Camshaft sprocket to camshaft .....	45
Cylinder head to cylinder block .....	25 + 60° + 60° + 60° 3) 4)
Cylinder head to cylinder block .....	55 + 60° + 60° + 30° 1) 3) 4)
Exhaust manifold to cylinder head .....	22
Front exhaust pipe to exhaust manifold .....	25
Fuel pump to camshaft housing .....	18 5)
Intake air preheating scoop to exhaust manifold .....	8
Intake manifold to cylinder head .....	22
Pulley to pump for power steering .....	25 6)
Rear toothed belt cover to camshaft housing .....	6 7)
Rear toothed belt cover to camshaft housing .....	12 1)
Spark plugs to cylinder head .....	25
Thermostat housing to cylinder head .....	10 1)
Thermostat housing to cylinder head .....	15 2)

1) 1,4/1,6 ltr. engine

2) 1,8/2,0 ltr. engine

3) Use new bolts.

4) After test run turn a further 30° + 15°.

5) Only 14 NV engine.

6) Only 1,6 ltr. with power steering.

### Rear Seal Ring in Camshaft Housing — Replace (1,8/2,0 ltr.)

#### REMOVE, DISCONNECT

1. High voltage distributor.
2. Seal ring — installing lever.  
Do not damage camshaft housing.

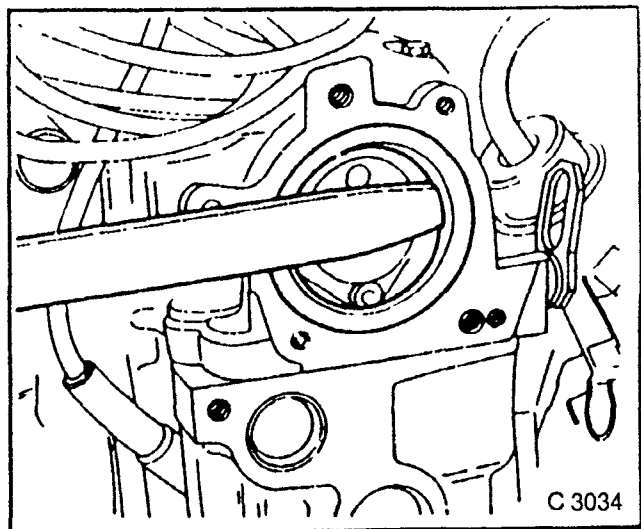


Fig. 49

**INSTALL, CONNECT**

1. Seal ring with KM-636
2. High voltage distributor

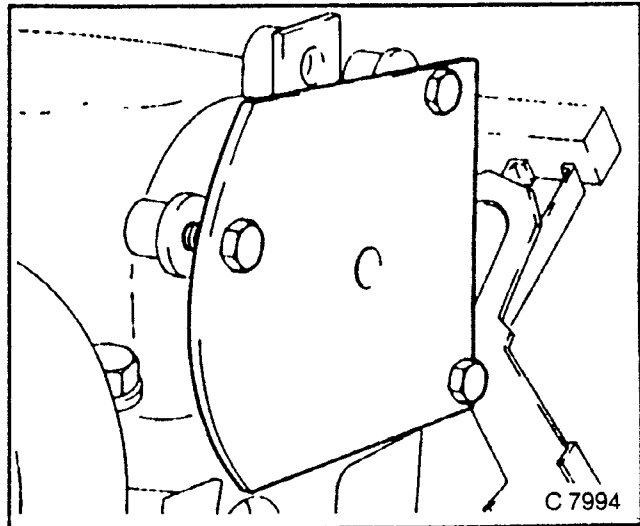


Fig. 50

**Front Seal Ring in Camshaft Housing — Replace**

Release toothed belt and remove from camshaft timing gear — see operation “Toothed Belt, Replace”. Page 24.

**REMOVE, DISCONNECT**

1. Camshaft housing cover.
2. Camshaft timing gear.

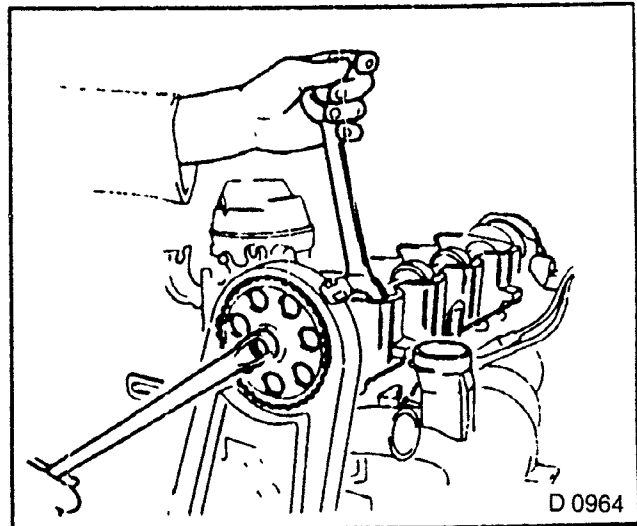


Fig. 51

**REMOVE, DISCONNECT**

1. Seal ring
  - drill hole in centre
  - turn in self-tapping screw
  - lever out seal ring.

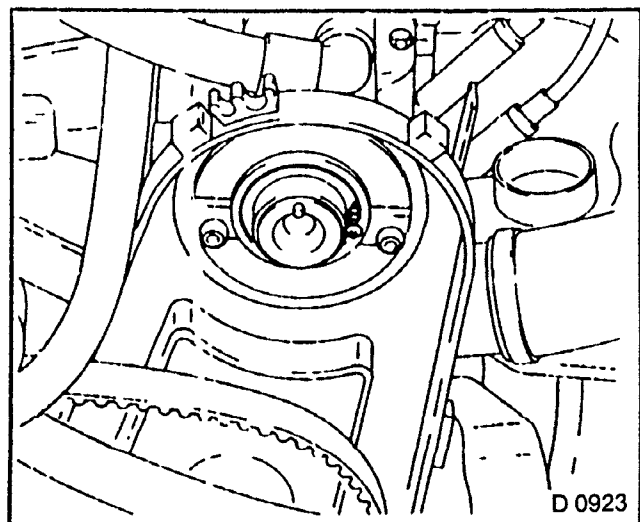


Fig. 52

**INSTALL, CONNECT**

1. Seal ring with KM-422.
2. Use bolt and washer of camshaft timing gear.
3. Coat sealing lip of seal ring lightly with protective grease.

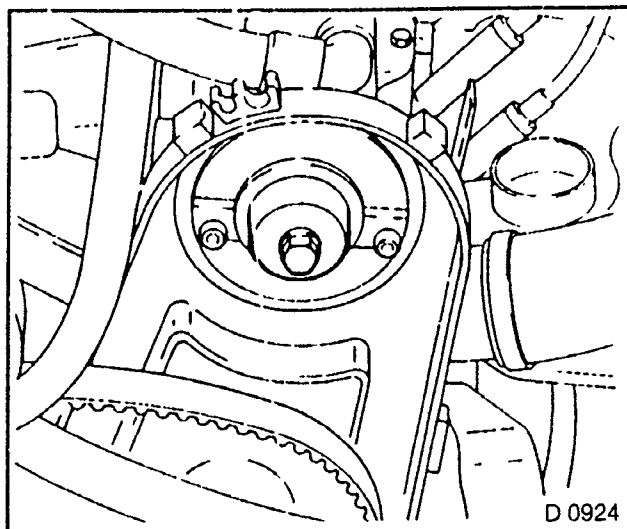


Fig. 53

**TIGHTEN (TORQUE)**

1. Camshaft timing gear to camshaft  
— 45 Nm.
2. Camshaft housing cover to housing  
— 8 Nm.
3. Install and tension toothed belt.

**Gasket — Exhaust Manifold/Cylinder Head — Replace****REMOVE, DISCONNECT**

1. Front exhaust pipe from exhaust manifold.
2. If present:
  - Pre-heater hose.
  - Pre-heater scoop from exhaust manifold.
3. Exhaust manifold from cylinder head.

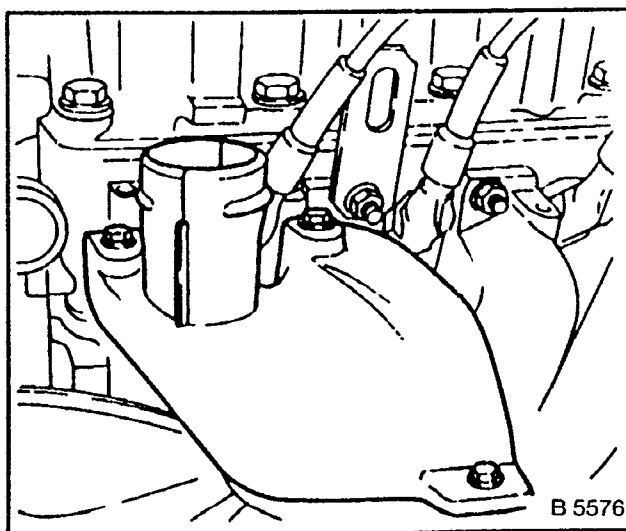


Fig. 54

**CLEAN**

1. Sealing surfaces.
2. Insert new gasket.

**TIGHTEN (TORQUE)**

1. Exhaust manifold to cylinder head  
— 22 Nm.
2. Front exhaust pipe to exhaust manifold  
— 25 Nm.
3. Pre-heater scoop to exhaust manifold  
— 8 Nm.
4. Install pre-heater hose.

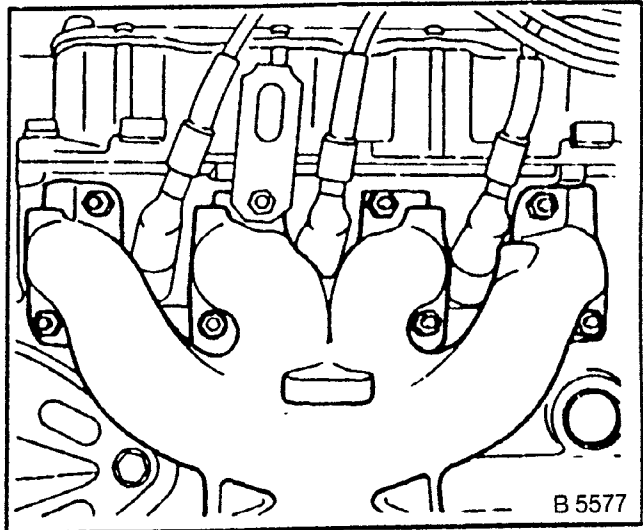


Fig 55

## Gasket — Intake Manifold/Cylinder Head — Replace (C 16SE)

**REMOVE, DISCONNECT**

1. Ground cable from battery.
2. Air intake hose (1).
3. Engine vent hoses (2) from throttle body.
4. Lower coolant hose — collect coolant.

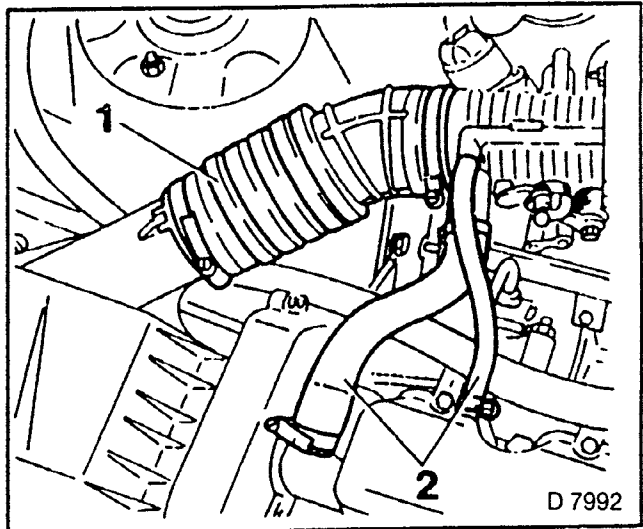


Fig 56

**REMOVE, DISCONNECT**

1. Upper alternator fastening.
2. Remove V-belt.
3. Swing alternator backwards.
4. Bowden cable.
5. Brake servo vacuum line from intake manifold.

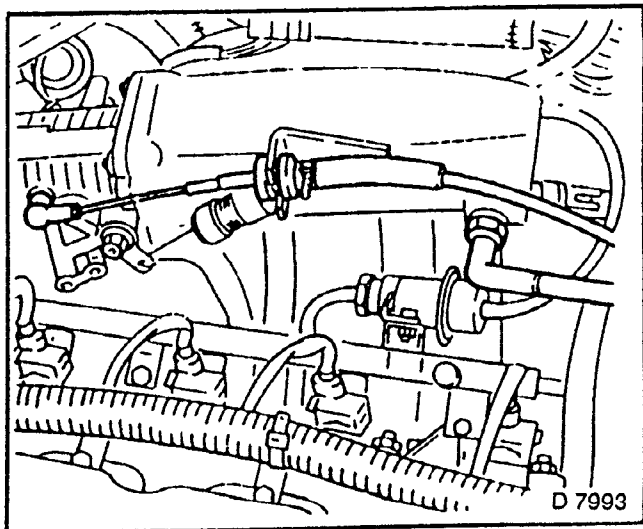


Fig. 57



**REMOVE, DISCONNECT**

1. Wiring harness plug (1) from intake air temperature sensor.
2. Wiring harness plug (2) from injection valves.
3. Wiring harness plug from coolant temperature sensor.

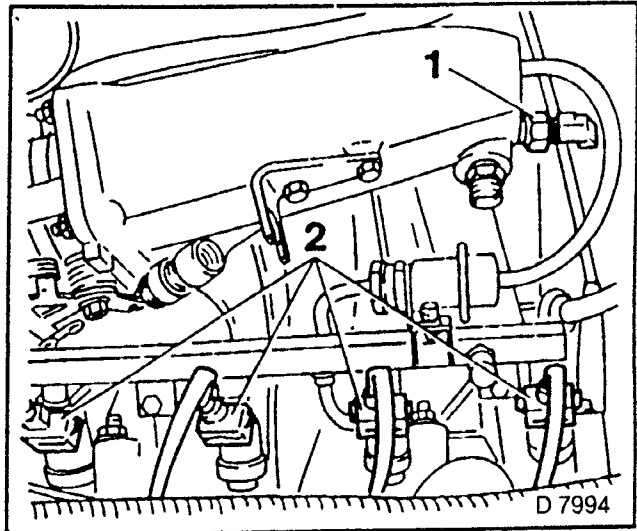


Fig. 58

**REMOVE, DISCONNECT**

1. Wiring harness plug (1) from throttle valve potentiometer.
2. Wiring harness plug (2) from idle speed stepper motor.

Note routing of leads.

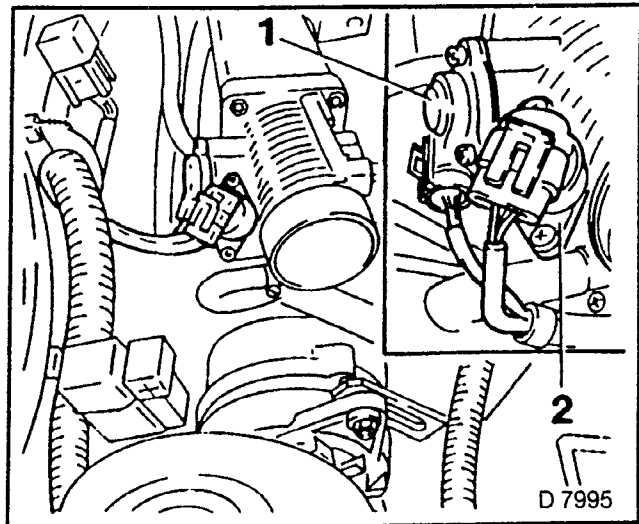


Fig. 59

**REMOVE, DISCONNECT**

1. Fuel lines — mark and close off with spring clamps.

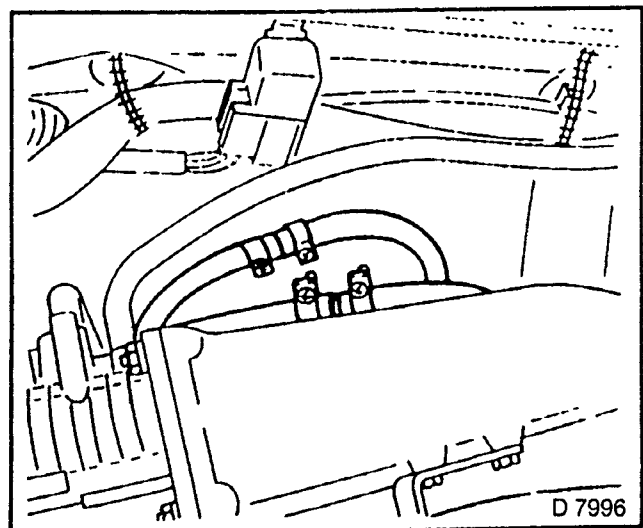


Fig. 60

**REMOVE, DISCONNECT**

1. Coolant hose from intake manifold.
2. Coolant hoses and vacuum hoses from throttle body.
3. Ground connections.
4. Intake manifold from cylinder head.

**CLEAN**

Sealing surfaces.

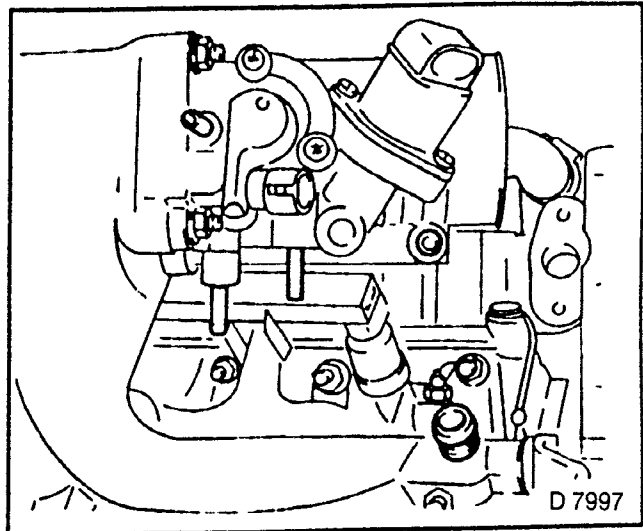


Fig. 61

**TIGHTEN (TORQUE)**

1. Intake manifold to cylinder head — 22 Nm.
2. Use new gasket.
3. Ground connections — note correct seat.

**INSTALL, CONNECT**

1. Coolant hoses and vacuum hoses to throttle body and intake manifold.
2. Fuel lines marked.

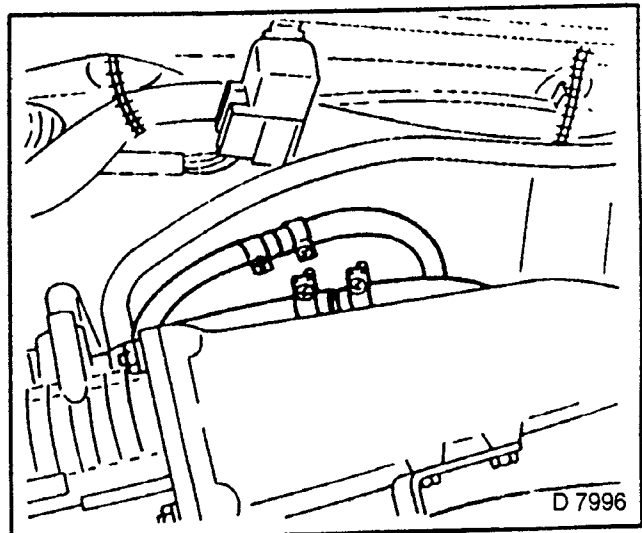


Fig. 62

**INSTALL, CONNECT**

1. Wiring harness plug (1) to throttle valve potentiometer.
2. Wiring harness plug (2) to idle speed stepper motor.
3. Wiring harness plug to intake air temperature sensor.
4. Wiring harness plug to injection valves.
5. Wiring harness plug to coolant temperature sensor.

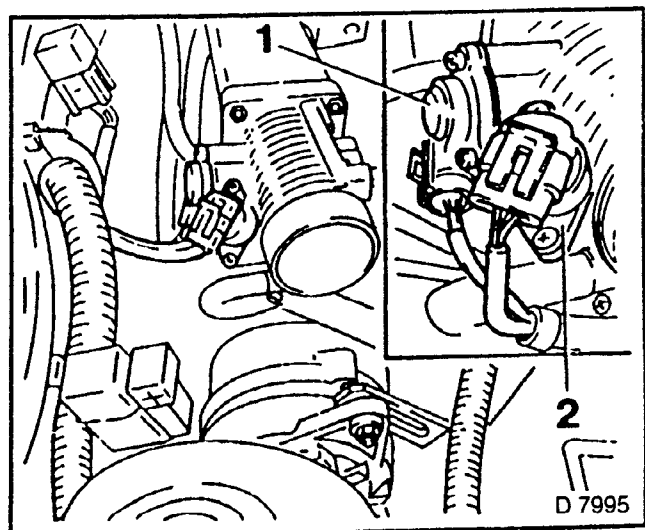


Fig. 63

## INSTALL, CONNECT

1. Brake servo vacuum line to intake manifold.
2. Bowden cable.
3. V-belt for alternator.
4. V-belt tension.

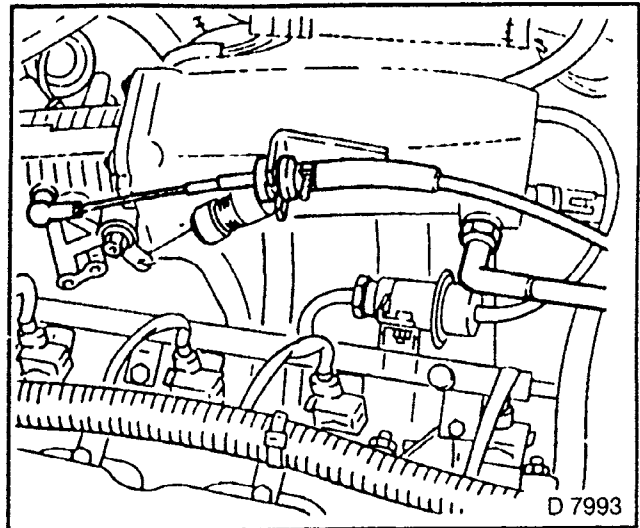


Fig. 64

## INSTALL, CONNECT

1. Air intake hose (1).
2. Engine vent hoses (2) to throttle body.
3. Lower coolant hose.
4. Ground cable to battery.
5. Top up and bleed cooling system.

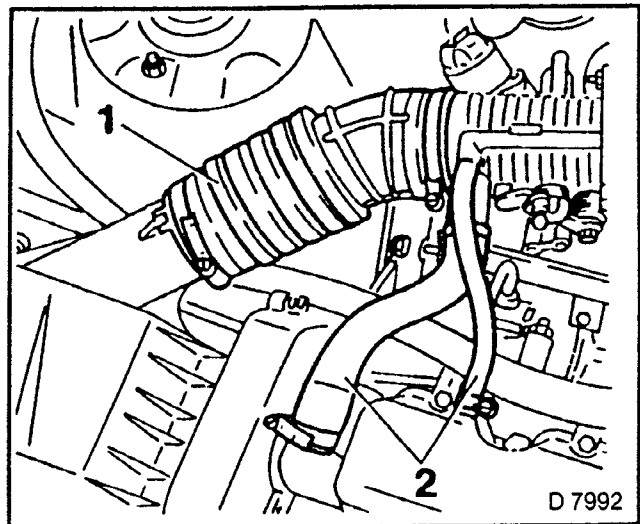


Fig. 65

## Hydraulic Valve Lash Adjuster — Replace

### REMOVE, DISCONNECT

1. Camshaft.
2. Rocker arms.
3. Valve lash adjuster.

4. Insert valve lash adjuster.

### ADJUST

Not necessary, as pre-tension has been taken into account during manufacture.

### INSTALL, CONNECT

1. Rocker arms.
2. Camshaft.

## Fuel Pump — Replace (14 NV)

### REMOVE, DISCONNECT

1. Ground lead from battery.
2. Fuel hoses — close off with spring clips.
3. Fuel pump from camshaft housing.

### CLEAN

1. Sealing surfaces.
2. Insert new gasket.

### TIGHTEN (TORQUE)

1. Fuel pump to camshaft housing — 18 Nm.
2. Attach fuel hoses.
3. Remove spring clips.
4. Ground cable to battery.

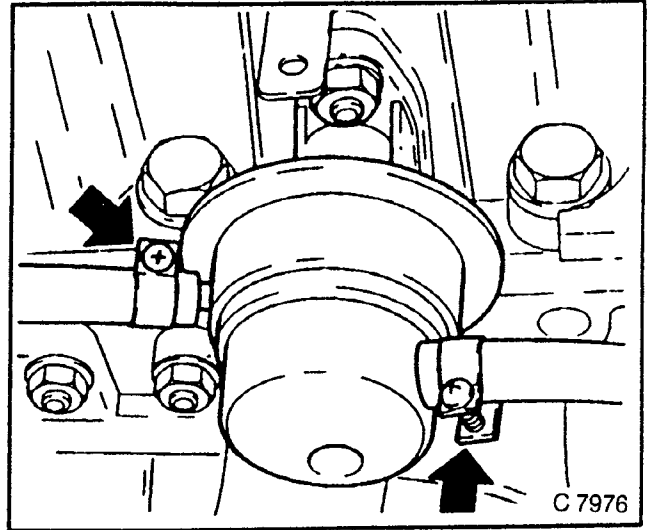


Fig. 66

## Camshaft and Rocker Arm — Remove and Install

### REMOVE, DISCONNECT

1. Ground cable from battery.
2. Oil reservoir for power steering.
3. If present — front toothed belt cover.
4. Fuel pump — if present (fuel hoses remain connected).
5. Camshaft housing cover.
6. Bring all pistons to centre position — 90° CA BTDC.
7. Turn crankshaft in engine rotational direction.

### REMOVE, DISCONNECT

1. Camshaft pulley — relax tension on toothed belt and remove.
2. Ignition distributor.
3. Rear seal ring from camshaft housing — if present (with installing lever, do **not** damage camshaft housing).
4. Thrust plate.

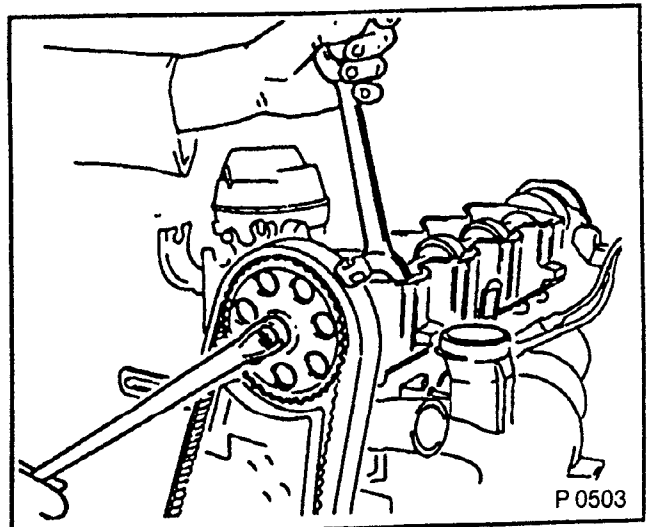


Fig. 67

**REMOVE, DISCONNECT**

1. Camshaft from camshaft housing.
2. Position commercially available valve holder (manufactured by Sauer, Germany) and hold all rocker arms down equally. Observe manufacturer's instructions
3. Camshaft from camshaft housing.
4. Release tension on valve holder and remove.
5. Remove rocker arms and pushers.

**INSPECT**

1. All parts.
2. Replace all rocker arms when replacing camshaft.

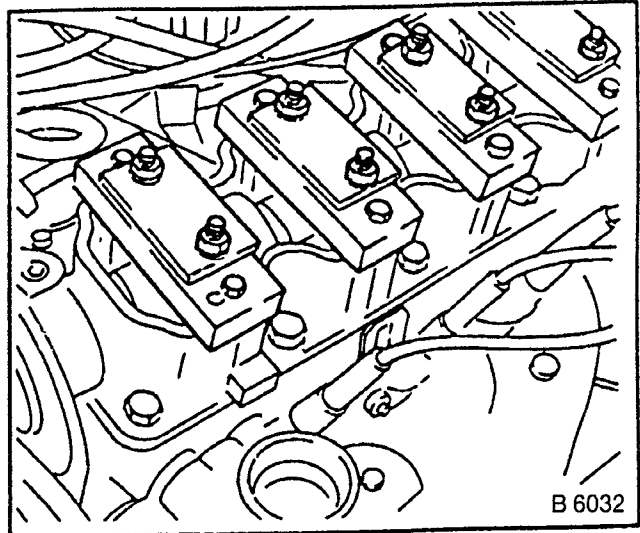


Fig. 68

**INSTALL, CONNECT**

1. Pushers.
2. Rocker arms — tension with valve holder.
3. Coat sliding surfaces with  $\text{MOS}_2$  paste.
4. Camshaft in camshaft housing.

**TIGHTEN (TORQUE)**

1. Thrust plate for camshaft to camshaft housing — 8 Nm.
2. Remove valve holder.

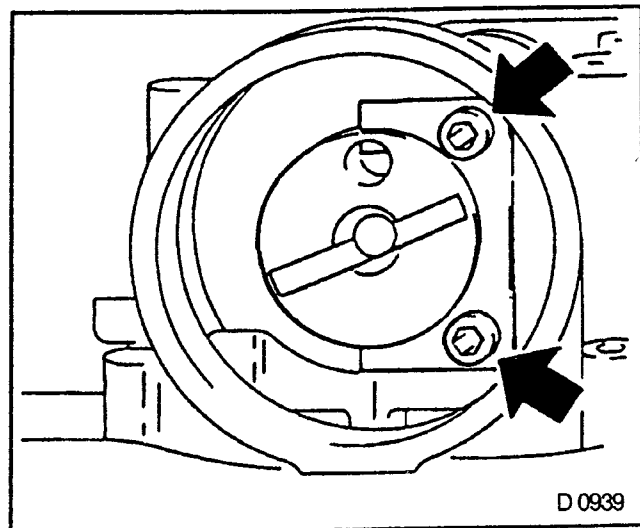


Fig. 69

**INSTALL, CONNECT**

1. Rear seal ring into camshaft housing — KM-636.
2. Ignition distributor.

**TIGHTEN (TORQUE)**

1. Camshaft pulley to camshaft — 45 Nm.
2. Fuel pump to camshaft housing — 18 Nm.

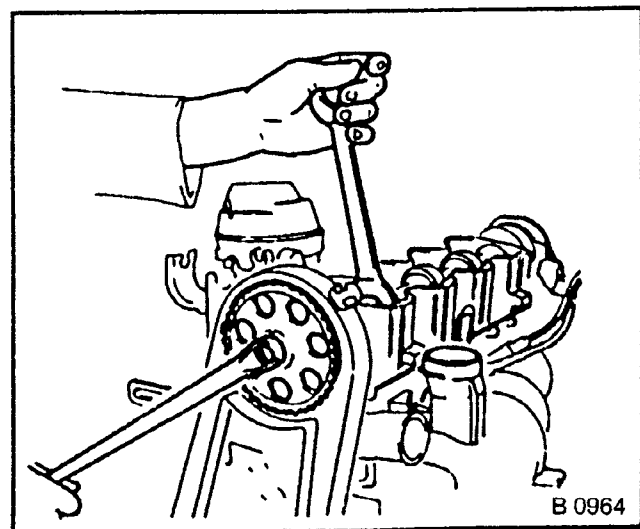


Fig. 70

**INSTALL, CONNECT**

1. Install toothed belt and tension.
2. Camshaft housing cover.
3. Front toothed belt cover.
4. Power steering fluid reservoir.
5. Ground cable to battery.

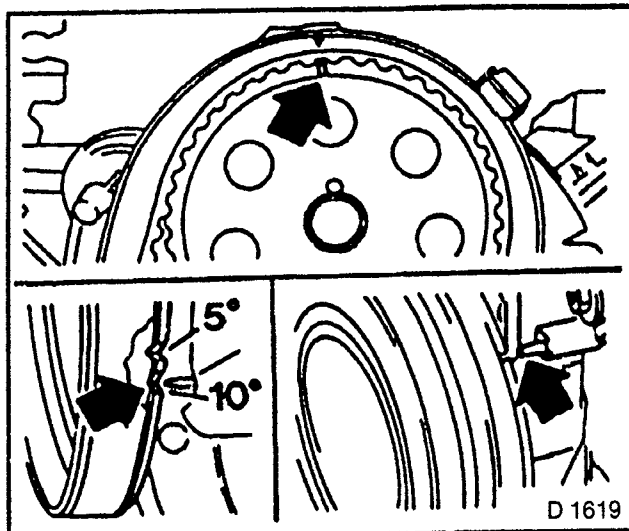


Fig. 71

**Camshaft Housing — Replace****REMOVE, DISCONNECT**

1. Cylinder Head.
2. Ignition distributor.
3. If present:
  - Fuel pump
  - Rear seal ring
  - Thrust plate
  - Camshaft
  - Front seal ring.

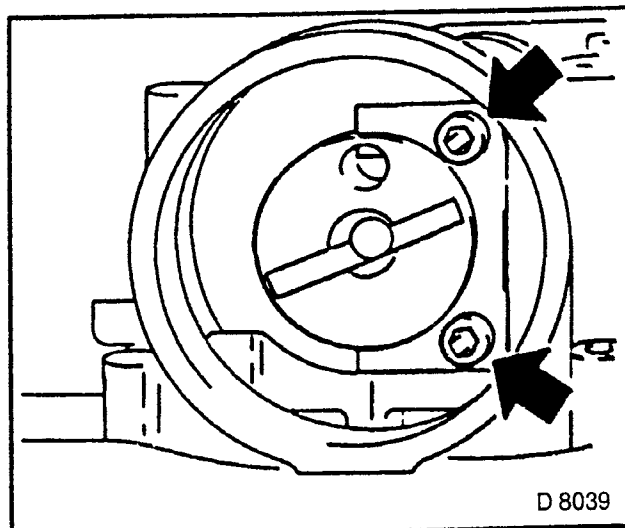


Fig. 72

**INSPECT**

1. Replace all parts, if necessary.
2. Always replace all rocker arms when replacing camshaft.

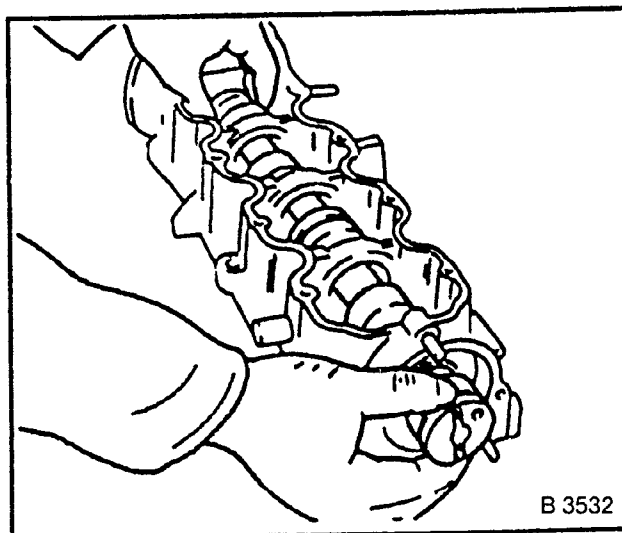


Fig. 73

**TIGHTEN (TORQUE)**

1. Guide plate to camshaft housing  
— 8 Nm.
2. Insert camshaft with MOS<sub>2</sub> paste.

**INSTALL, CONNECT**

1. 1,8/2,0 ltr.: rear seal ring — KM-636.
2. Front seal ring — KM-422.

**TIGHTEN (TORQUE)**

1. Fuel pump to camshaft housing  
— 18 Nm (14 NV).

**INSTALL, CONNECT**

1. Cylinder head.
2. Ignition distributor.

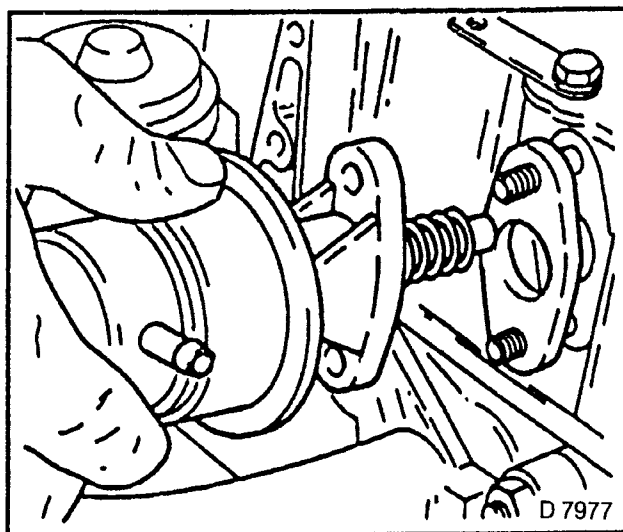


Fig. 74

**Strainer (Filter) in Camshaft Housing Cover — Clean**

**NOTE:**  
THE STRAINER (FILTER) CANNOT BE REMOVED FROM THE 16 SE ENGINES.

**REMOVE, DISCONNECT**

1. Camshaft housing cover.
2. Cleaner.

**CLEAN**

1. Sealing surfaces.
2. Cleaner.

**INSTALL, CONNECT**

1. Cleaner.
2. Camshaft housing cover to housing  
— 8 Nm.

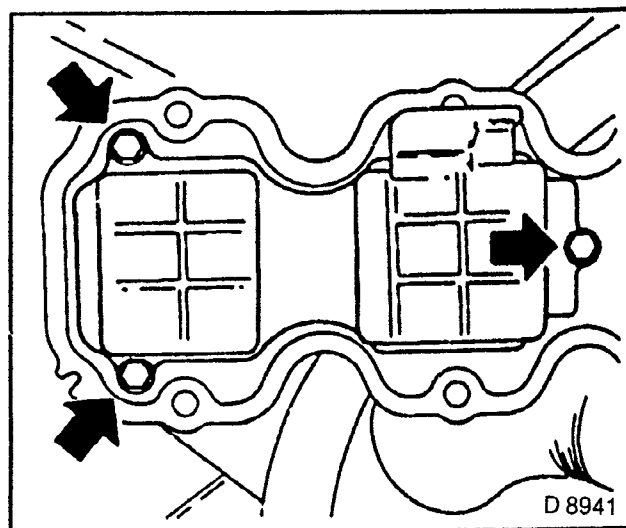


Fig. 75

## Spark Plug Thread — Recondition

Remove cylinder head.

Ream thread and recut — commercially available spark plug thread drill (observe manufacturer's instructions).

### INSTALL, CONNECT

Thread bush on spark plug — dimension (1) — 17 mm.

### TIGHTEN (TORQUE)

Spark plug with threaded bushing into cylinder head — 25 Nm.  
Install cylinder head.

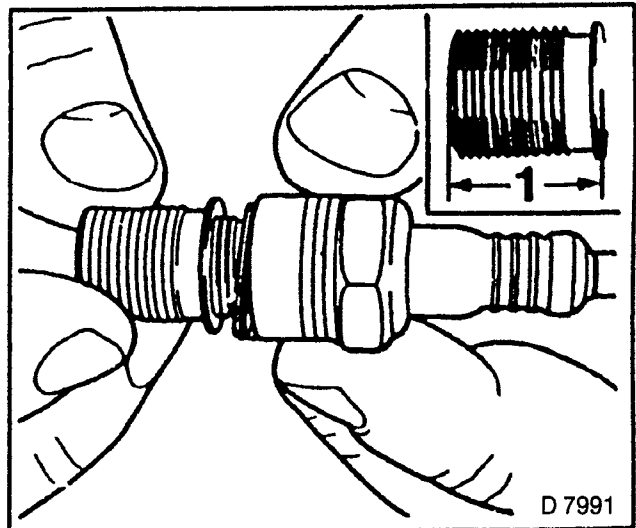


Fig. 76

## Cylinder Head — Remove and Install

The following describes the removal of the cylinder head on the 18SE/20SEH engine. Proceed similarly for all other engines.

**NOTE:**  
**REMOVE CYLINDER HEAD ONLY FROM COLD ENGINE (ROOM TEMPERATURE).**

### REMOVE, DISCONNECT

1. Ground cable from battery.
2. Lower hose bend from pipe bend — collect coolant.
3. Upper hose bend.
4. Air cleaner
5. If present:
  - Air intake hose
  - Pre-volume chamber.
6. Drive belt for alternator.

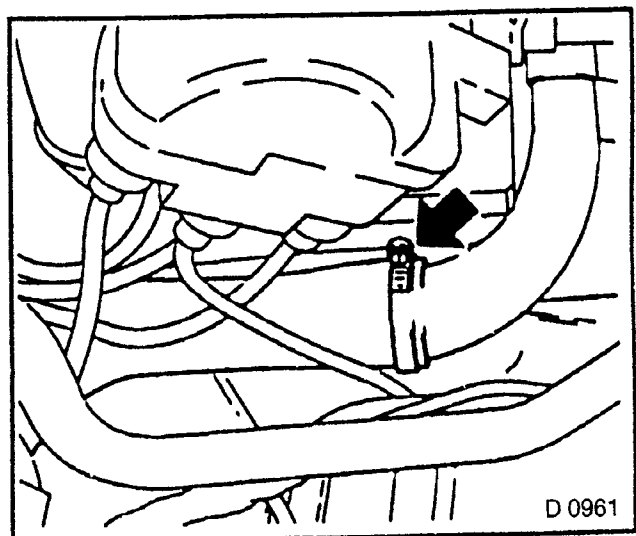


Fig. 77



**REMOVE, DISCONNECT**

Mark fuel hoses before removal and close off with spring clamps.

1. Cable connections.
2. Hoses and leads from cylinder head.
3. Accelerator cable.
4. Pulley from power steering pump.

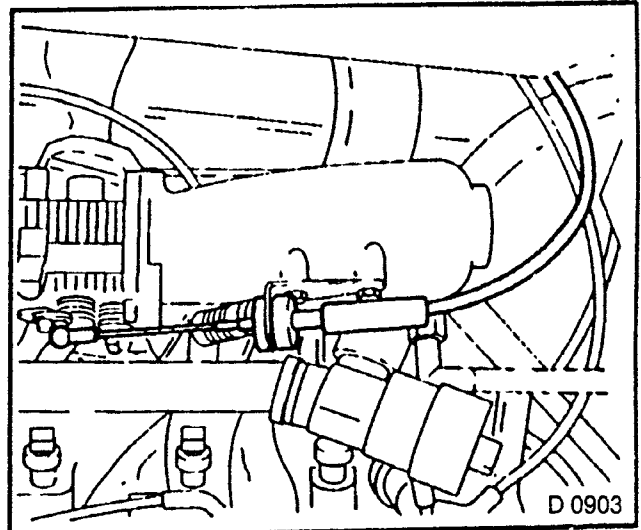


Fig. 78

**REMOVE, DISCONNECT**

1. Front toothed belt cover.
2. Position piston of 1st cylinder at TDC.
3. Position of timing markings — see “Timing, Check and Adjust”, page 15.
4. Release tension of toothed belt and remove — see “Toothed Belt, Replace”, page 24.
5. Camshaft housing cover.
6. Camshaft pulley.

**REMOVE, DISCONNECT**

1. Upper bolts of rear toothed belt cover.
2. Exhaust pipe from exhaust manifold.
3. Disconnect oxygen sensor wiring harness plug (C 16 SE).
4. Cylinder head.
5. Loosen bolts from outside inwards (at first quarter turn then half turn) in a spiral pattern.
6. Camshaft housing from cylinder head.
7. Remove rocker arm.
8. Pressure parts.
9. Hydraulic valve lash adjuster.

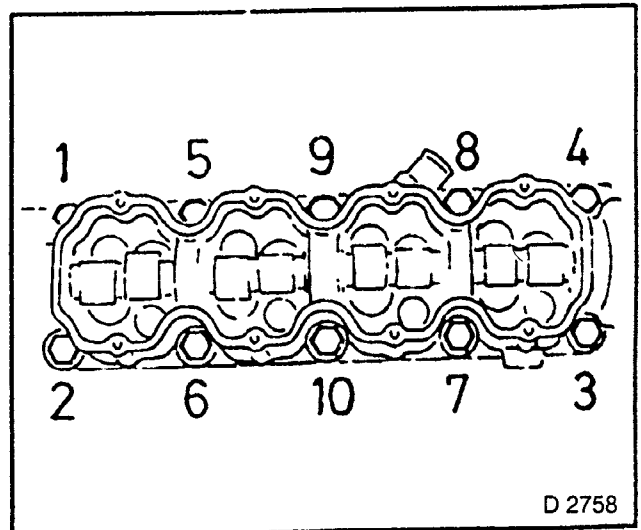


Fig 79

**CLEAN**

1. All sealing surfaces.
2. Bore holes in cylinder head bolts.
3. Check cylinder block and cylinder head for plane surface.

**INSTALL, CONNECT**

1. Cylinder head sealing — marking "OBEN/TOP" facing upwards and to steering side of the engine.

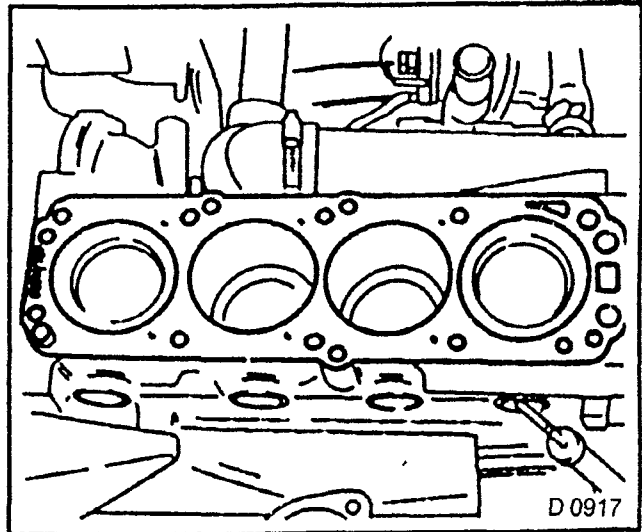


Fig. 80

**INSTALL, CONNECT**

1. Place cylinder head on cylinder block.
2. Insert hydraulic valve lash adjuster, pressure parts and rocker arm — MoS<sub>2</sub> paste.
3. Insert camshaft housing — Sealing Compound Loctite 242.

**NOTE:**

1. Use new cylinder head bolts.
2. Screw in bolts until they rest on cover.

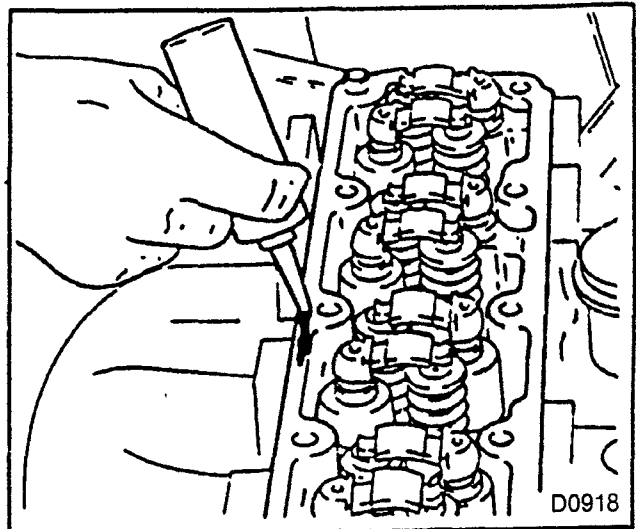


Fig. 81

**TORQUE — ANGLE METHOD**

1. Cylinder head to cylinder block.
2. Tighten cylinder head bolts from inside outwards, in four stages in a spiral pattern — torque wrench and KM-470-B.

Engine	Torque	Further turn angle
1,4 / 1,6 Ltr.	55 Nm	60° + 60° + 30°*
1,8 / 2,0 Ltr.	25 Nm	60° + 60° + 60°*

\*After test run, turn a further 30° + 15°

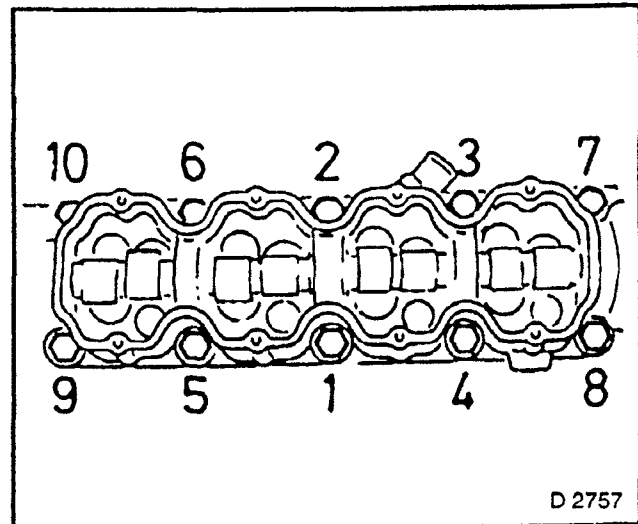


Fig. 82

**TIGHTEN (TORQUE)**

1. Toothed belt rear cover to camshaft housing  
1,4/1,6 ltr.: 12 Nm.  
1,8/2,0 ltr.: 6 Nm.
2. Camshaft gear to camshaft — 45 Nm.
3. Install and tension toothed belt.

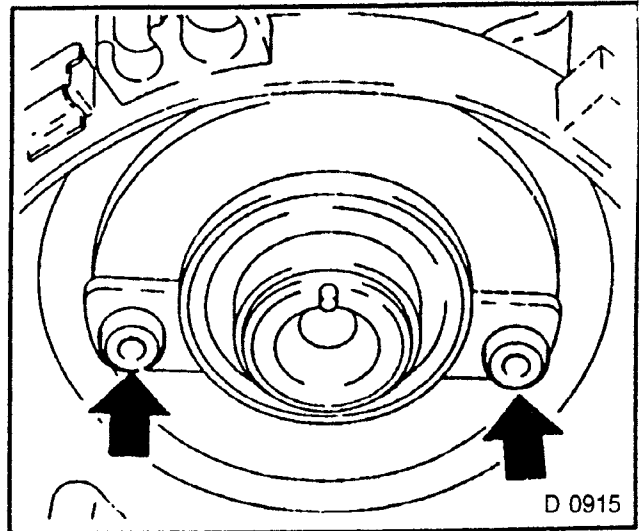


Fig. 83

**TIGHTEN (TORQUE)**

1. Camshaft housing cover to housing — 8 Nm.
2. Insert new gasket.
3. Install toothed belt front cover.

**INSTALL, CONNECT**

1. All hose, line, and cable connections to cylinder head.
2. Note condition and seating.
3. Observe marks on fuel lines when installing — remove spring clips.
4. Install accelerator cable free of tension
5. Drive belt for alternator
6. On 1,6 ltr. with power steering: pulley to pump — 25 Nm.
7. Air cleaner.
8. Pre-volume chamber.
9. Air intake hose.

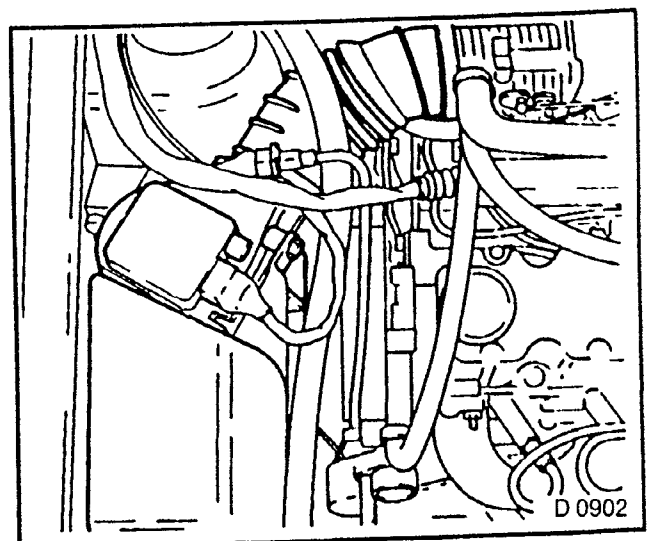


Fig. 84

**INSTALL, CONNECT**

1. Front exhaust pipe.
2. Ground lead to battery.
3. Fill up cooling system.
4. Bleed and check for leaks.

**NOTE:**  
**AFTER ENGINE TEST RUN, TURN CYLINDER HEAD BOLTS SPIRALLY FROM INSIDE OUTWARDS A FURTHER 30° + 15°.**

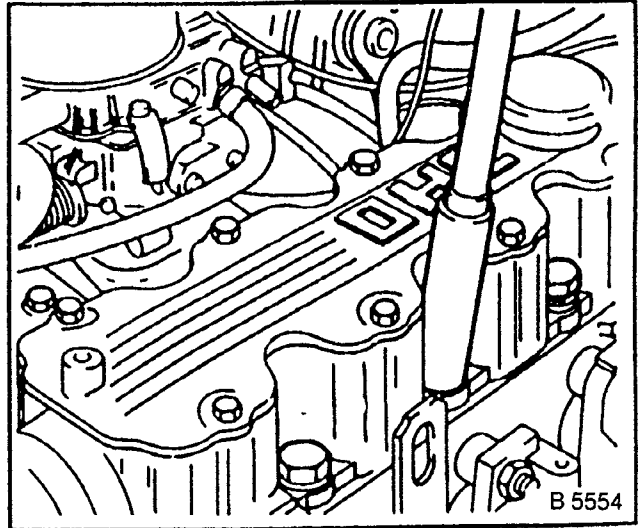


Fig. 85

## Cylinder Head — Disassemble and Assemble

**REMOVE, DISCONNECT**

1. Exhaust manifold.
2. Intake manifold.
3. Thermostat housing.
4. Thermostat (on 1,4 and 1,6 ltr. engines).
5. Spark plugs.
6. Tension valve springs — KM-348.
7. Valve cones.
8. Valve spring plates.
9. Valve springs.
10. Valves.
11. Valve rotators (exhaust).
12. Spring seat rings (inlet).
13. Mark valves.

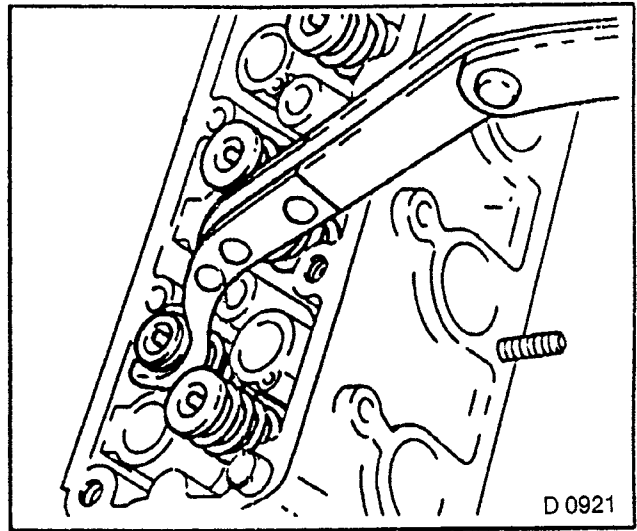


Fig. 86

**CLEAN, INSPECT**

1. Individual parts.
2. Sealing surfaces.
3. Guides.
4. Sliding points.
5. Bearing beds

**WARNING:**

**DO NOT DAMAGE VALVE SEATINGS.**

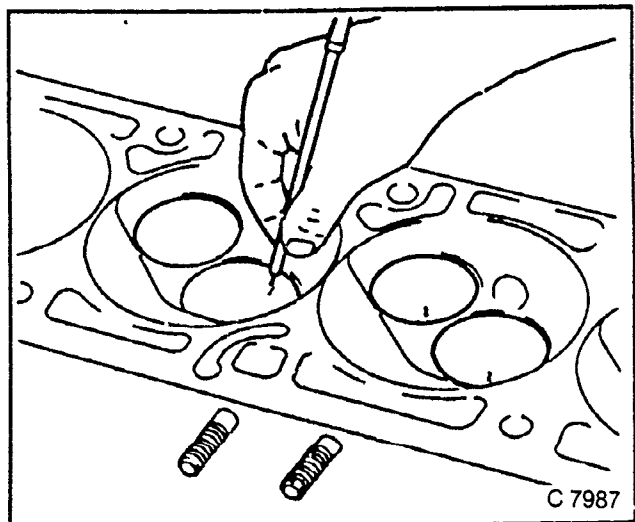


Fig. 87

## INSTALL CONNECT

1. Valves.
2. Valve rotators (exhaust).
3. Spring seat rings (inlet)
4. New valve stem seals — with installing sleeve and KM-352.
5. Valve springs.
6. Valve spring plates.
7. Valve cones — KM-348.
8. Thermostat or thermostat housing with new seal ring.

### NOTE:

1. Insert valves with engine oil.
2. Install valve stem seals with mounting sleeve.

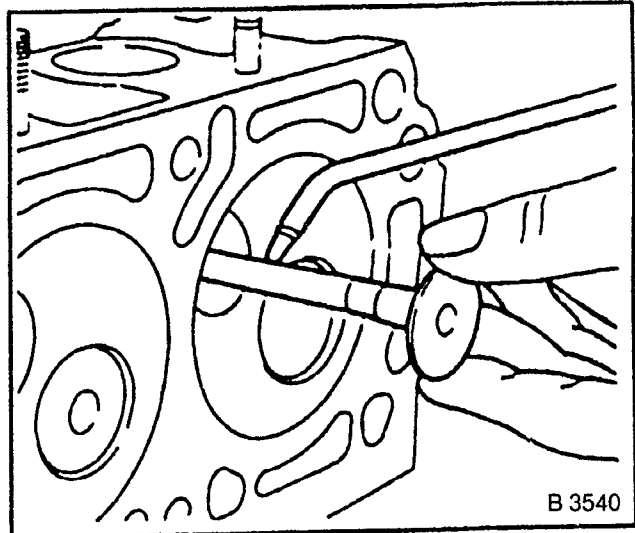


Fig. 88

## TIGHTEN (TORQUE)

1. Exhaust manifold to cylinder head — 22 Nm.
2. Intake manifold to cylinder head — 22 Nm.
3. Thermostat housing to cylinder head:  
1,4/1,6 ltr. engine: 10 Nm.  
1,6/2,0 ltr. engine: 15 Nm.
4. Spark plugs to cylinder head — 25 Nm.

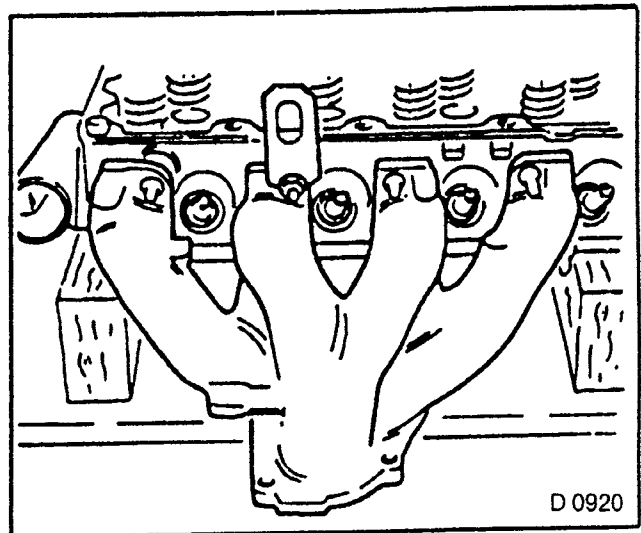


Fig. 89

## Cylinder Head — Overhaul

Cylinder head disassembled

### VALVE, GRIND IN

1. Oil valve stem.
2. Use fine-grained grinding past, lift up valve from seating in a rhythmical manner — distribution of grinding paste.

### CLEAN

1. Valves.
2. Cylinder head.

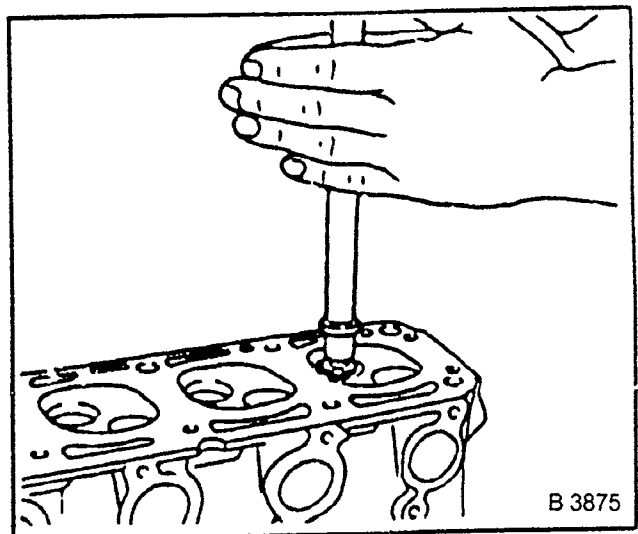


Fig 90

## Valve — Grind

### WARNING:

- 1 No crater — like burns on valve cone.
- 2 Re-grinding possible once or twice.
- 3 Angle on valve plate: 46°, see also "Technical Data".
- 4 Dimension "1" must not be exceeded.
- 5 Grinding on valve stem end not permissible.

### INSPECT

1. Valve stem projection  
 1,4/1,6 ltr. engine: KM-419  
 1,8/2,0 ltr. engine: KM-512.

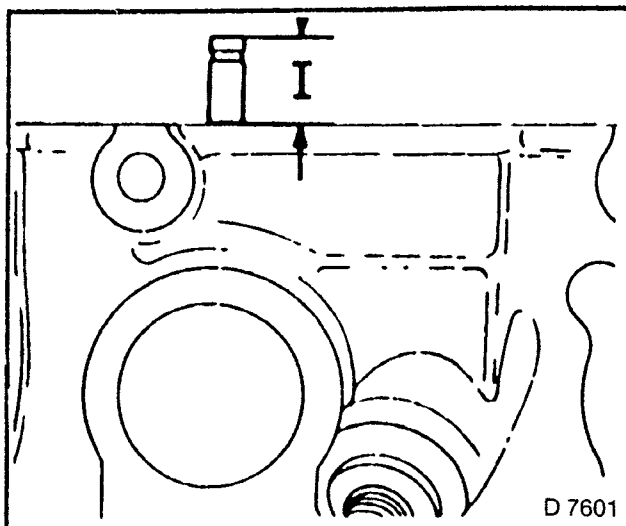


Fig 91

## Valve Guide — Ream

### MEASURE

1. Diameter of valve guide — dial gauge and internal measuring instrument.

**NOTE:**  
**VALVE OVERSIZES ARE ALREADY AVAILABLE EX WORKS.**  
**OVERSIZE IDENTIFICATION: ON THE VALVE GUIDE AND ON THE VALVE STEM END WITH THE FOLLOWING LISTED IDENTIFICATION FIGURES/LETTERS. SEE ALSO "TECHNICAL DATA", PAGE 312.**

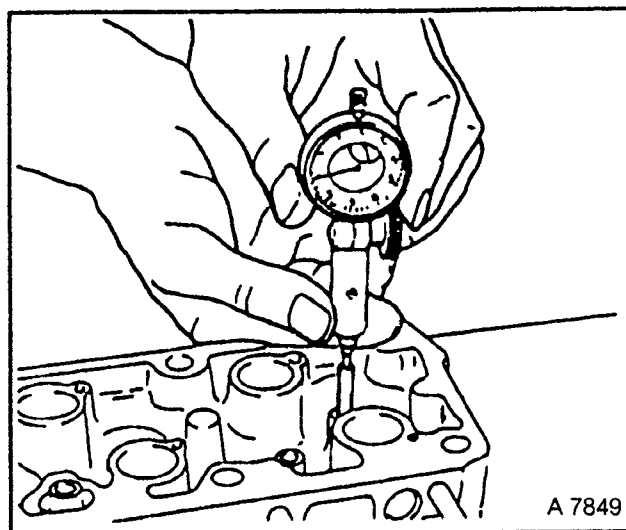


Fig 92

Size	Reamer	Identification	
		Production	Service
Normal		none	K
0,075	KM-253	1	K1
0,150	KM-254	2	K2
0,250	KM-255	—	A

Ream valve guide from upper side of cylinder head to next oversize.  
 After reaming, cross out identification mark and stamp in new identification mark.

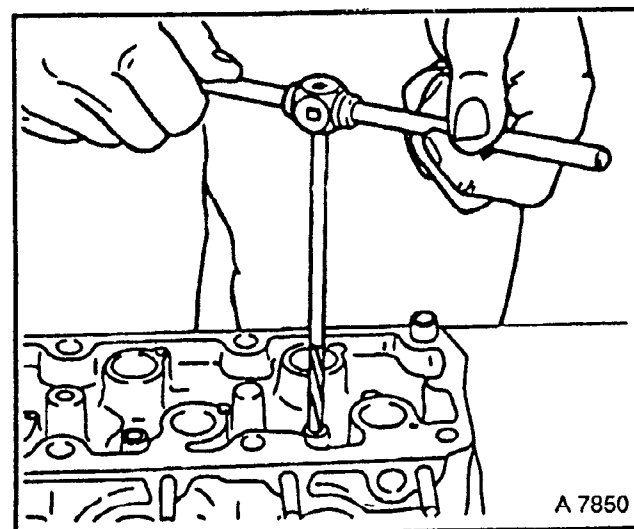


Fig. 93

## Valve Seating — Mill

Put down cylinder head on block of wood.  
 Inlet and exhaust — Guide Drift KM-340-7  
 and Valve Seat Cutter KM-340-11.  
 Valve seat —  $45^\circ$  — side face, upper  
 correction —  $30^\circ$  — side face (arrows on  
 cutter).

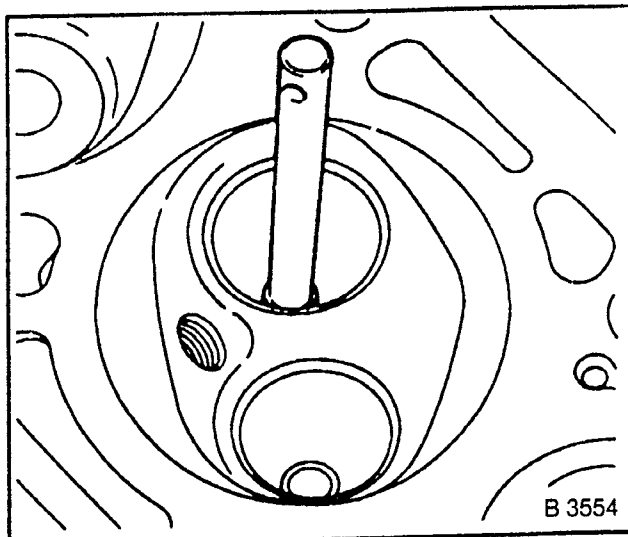


Fig. 94

Engine	Cutter	Valve seat width (in mm)	
		Inlet	Exhaust
1,4/1,6 ltr.	KM-340-11	1,3 to 1,5	1,6 to 1,8
1,8/2,0 ltr.	KM-340-11	1,0 to 1,5	1,7 to 2,2

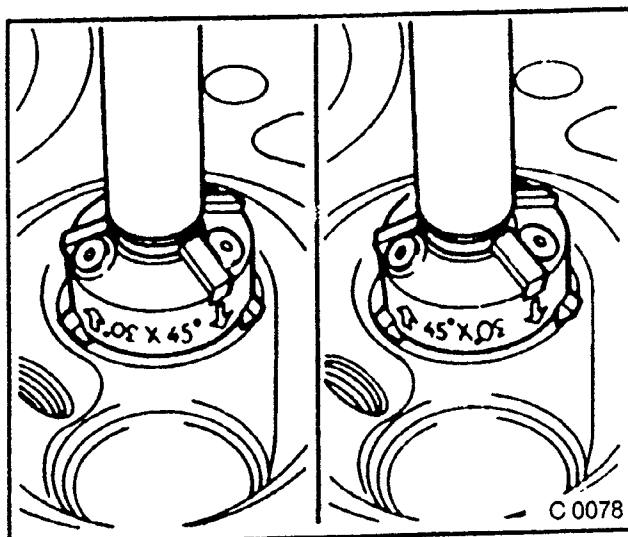


Fig. 95

## INSPECT

1. Valve stem projection.  
 1,4/1,6 ltr. engine: KM-419  
 1,8/2,0 ltr. engine: KM-512

## NOTE:

1. If dimension "1" is exceeded, use new valves.
2. Check valve stem projection again.
3. If dimension "1" is exceeded again:  
 replace cylinder head.

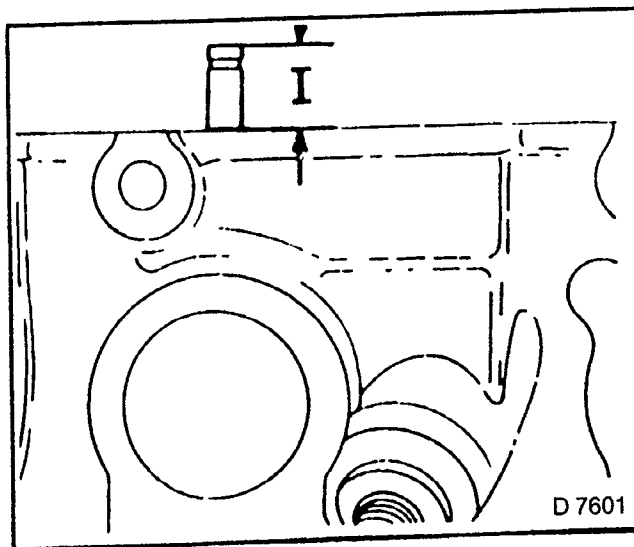


Fig. 96

## Cylinder Head — Check for Plane Surface

### INSPECT

1. Cylinder head for deformity and distortion — straight edge and feeler gauge. Permissible deviation — see “Technical Data”, page 312.

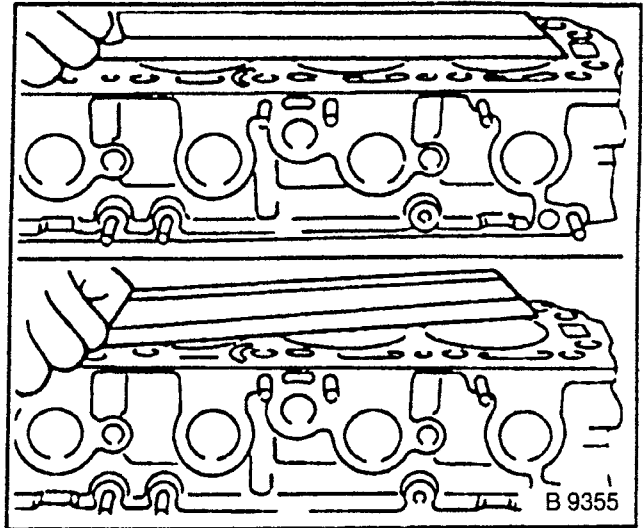


Fig. 97

### MEASURE

1. Cylinder head height (II) — for dimensions see “Technical Data”, page 312.

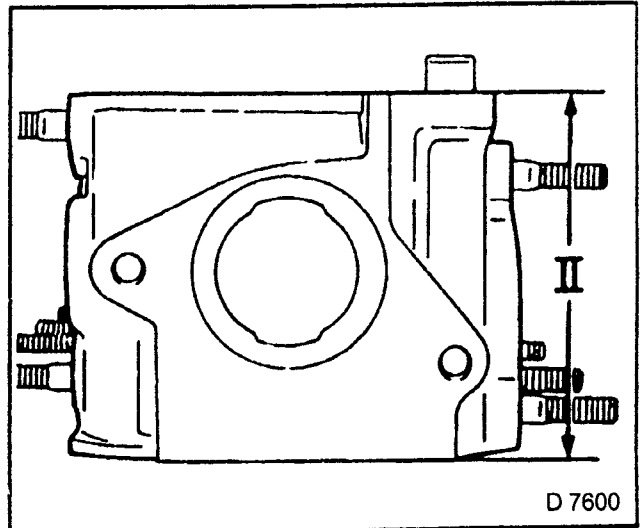


Fig. 98



# CRANK DRIVE

## Recommended Torque Values

	Nm
Con-rod bearing cover to con-rod .....	1)1)
Con-rod bearing cover to con-rod .....	35 + 45° + 15° 2)3)
Crankshaft bearing cover to cylinder block .....	50 + 45° + 15° 1)3)
Crankshaft bearing cover to cylinder block .....	50 + 45° + 15° 2)3)
Flywheel to crankshaft .....	35 + 30° + 15° 1)3)
Flywheel to crankshaft .....	65 + 30° + 15° 2)3)

- 1) 1,4/1,6 ltr. engine
- 2) 1,8/2,0 ltr. engine
- 3) Use new bolts.
- 4) Tighten bolt (thread length 15 mm) 6 22 412 (02 865 514) to 28 Nm.  
Tighten bolt (thread length 40 mm) 6 22 431 (90 281 728) to 25 Nm + 30° (use new bolt).

## Starter Ring Gear — Replace

### REMOVE, DISCONNECT

1. Flywheel.

### DISASSEMBLE

1. Drill starter ring gear underneath tooth gap approximately 8 mm deep with 6 mm drill.

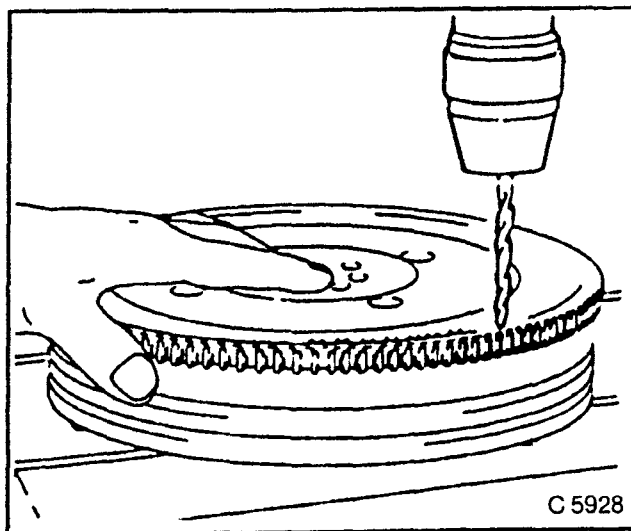


Fig. 99

### DISASSEMBLE

1. Separate starter ring gear with chisel on the drilling point.

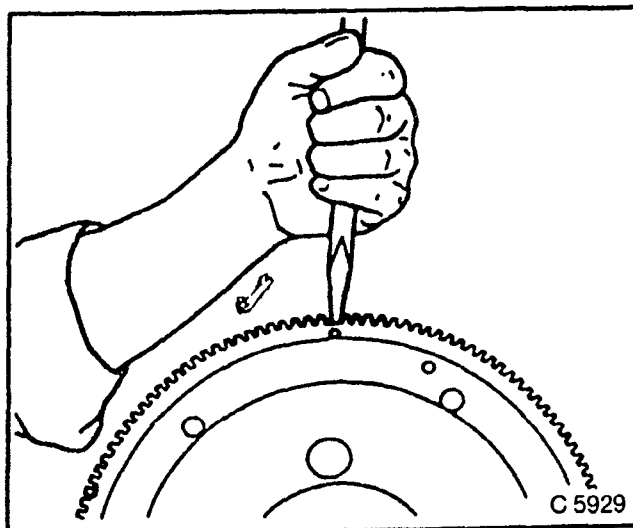


Fig. 100

**ASSEMBLE**

1. Starter ring gear with inner chamfered edge to flywheel.
2. Heat starter ring gear evenly to 180°C/356°F to 230°C/446°F (yellow burnished colour).

**INSTALL, CONNECT**

1. Flywheel.

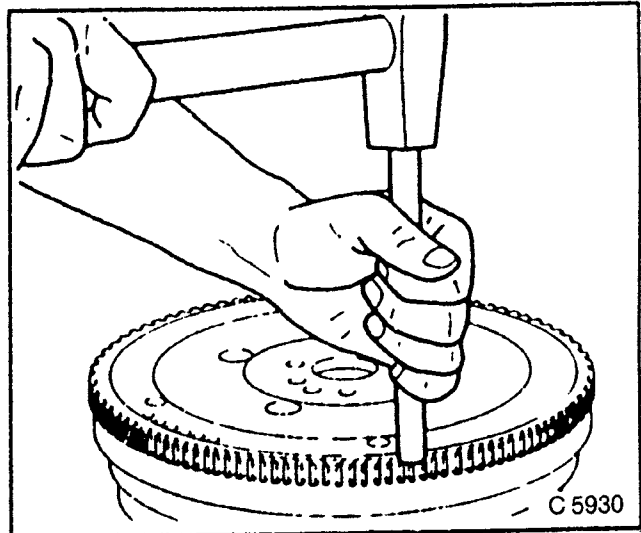


Fig. 101

**INSPECT**

1. Lateral run-out of starter ring gear — max. 0,5 mm.

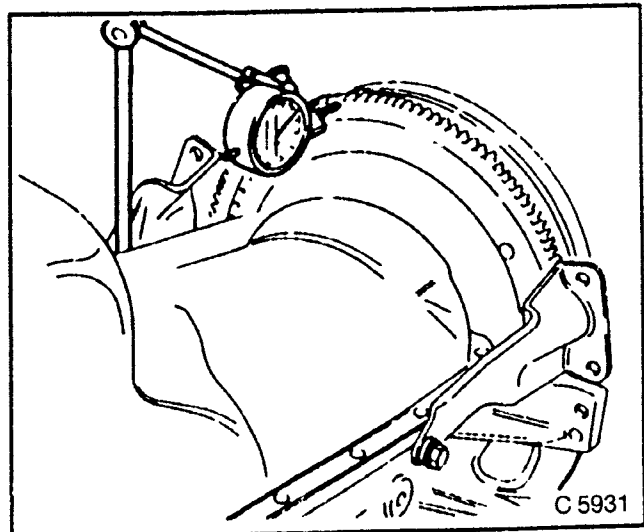


Fig. 102

**Drive Disc — Remove and Install (18SE only)****REMOVE, DISCONNECT**

1. Transmission — See Section K.
2. Drive disc — lock with KM-652.

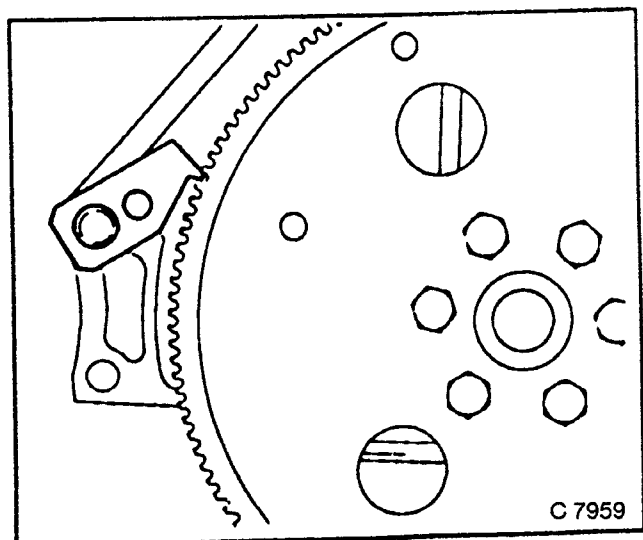


Fig. 103

**TIGHTEN (TORQUE)**

- 1 Drive disc to crankshaft — 60 Nm\*.  
\*Bolt must be recut before reuse and inserted coated with Locking Compound Loctite 242.

**INSTALL, CONNECT**

1. Transmission — see Section K.

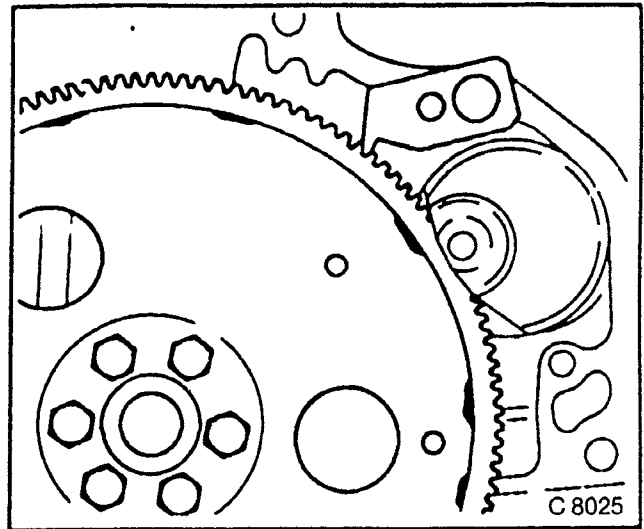


Fig. 104

## Seal Ring — Crankshaft — Front (in Oil Pump Housing) — Replace

**REMOVE, DISCONNECT**

1. Toothed belt.
2. Toothed belt drive gear.
3. If necessary: rear toothed belt cover.
4. Seal ring — make hole in middle of ring.
5. Screw in self-tapping screw and edge out.

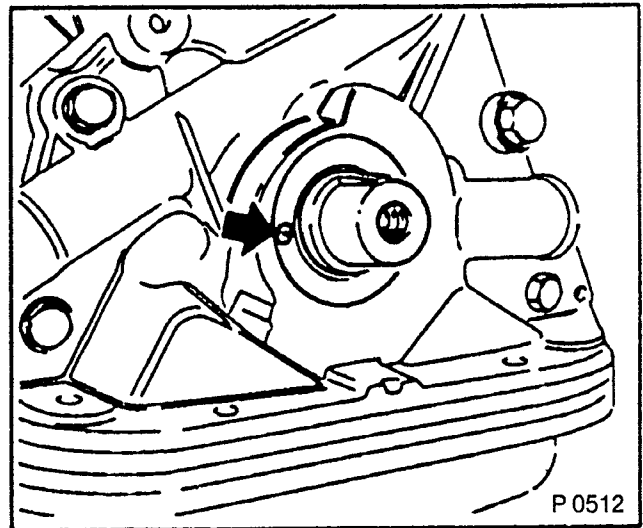


Fig. 105

**INSTALL, CONNECT**

1. Protective sleeve seal ring.
2. Coat seal lips of shaft seal ring with protective grease.

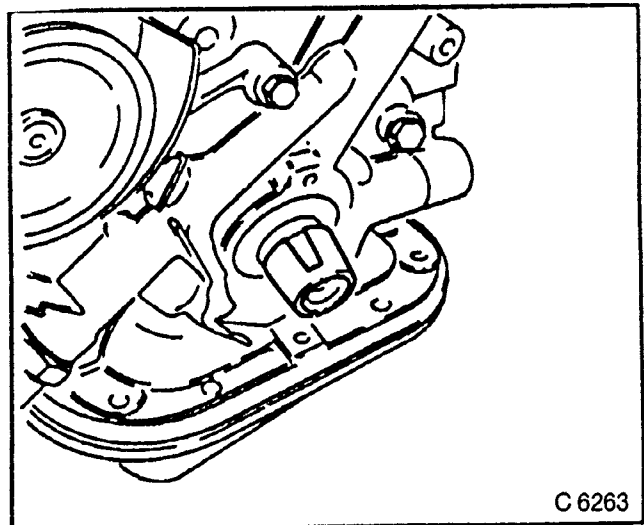


Fig. 106

**INSTALL, CONNECT**

1. Seal ring:
  - 1,4/1,6 ltr. engine: KM-417
  - 1,6/2,0 ltr. engine: KM-513-A.
2. If removed:
  - Rear toothed belt cover
  - toothed belt drive gear
  - toothed belt.

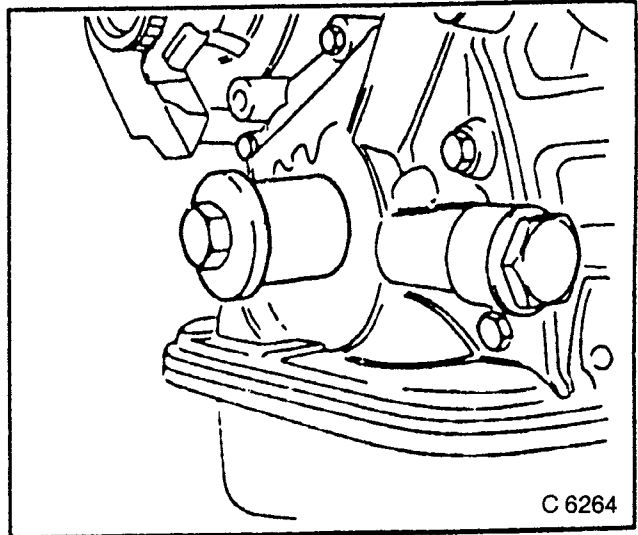


Fig. 107

**INSPECT**

1. After installation of the crankshaft pulley in C 16SE engines,
2. Check the distance between the inductive pulse pick-up and the increment disc.

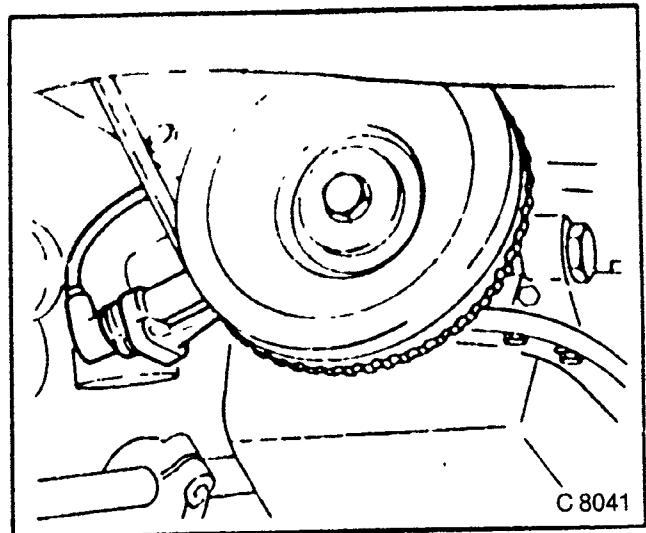


Fig. 108

## Seal Ring — Crankshaft — Rear — Replace (1,6 ltr. Engine)

**REMOVE, DISCONNECT**

1. Transmission.
2. Clutch (see Section K).
3. Drive disc or flywheel.
4. Make hole in middle of seal ring, turn in self-tapping screw and edge out.

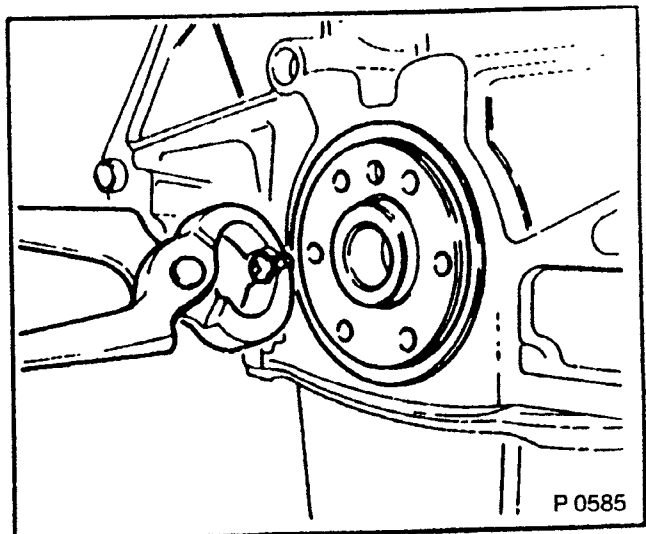


Fig. 109

**INSTALL, CONNECT**

1. Seal ring — protective sleeve.
2. Coat seal lips of shaft seal ring with protective grease. Use KM-535 or KM-635.
3. Flywheel or drive disc.
4. Clutch.
5. Transmission — see Section K.

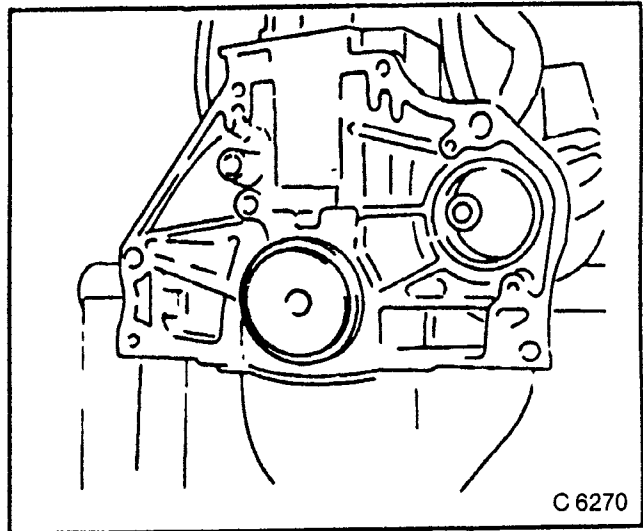


Fig. 110

## Seal Ring — Crankshaft — Rear — Replace (MT except for 1,6 ltr. Engine)

**REMOVE, DISCONNECT**

1. Clutch.
2. Thrust bearing — see Section K.
3. Flywheel.
4. Guide sleeve for thrust bearing.

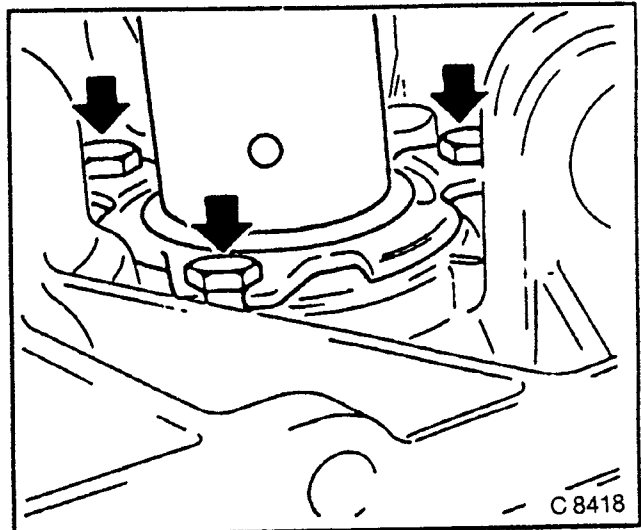


Fig. 111

**INSTALL, CONNECT**

1. Hook KM-469-6 between sealing lip and crankshaft journal.

**ASSEMBLE**

1. Support KM-469-4.
2. Lever KM-469-13-A.
3. Pin KM-328-8.

**REMOVE, DISCONNECT**

1. Shaft seal ring with assembly KM-469-A.

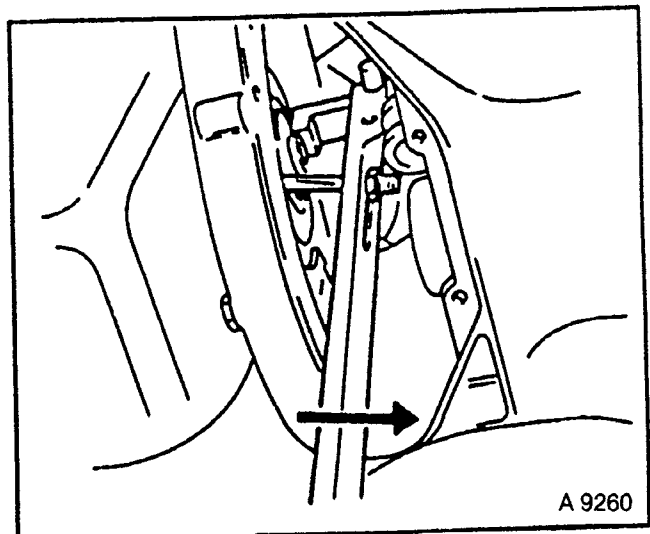


Fig. 112

2. Coat seal lips of shaft seal ring with protective grease.

### INSTALL, CONNECT

- 1 Seal ring onto crankshaft journal — protective sleeve:  
1,4 ltr. engine: KM-469-9  
1,8/2,0 ltr. engine: KM-635-1
2. Place thrust collar on seal ring:  
1,4 ltr. engine: KM-469-10  
1,8/2,0 ltr. engine: KM-635-2

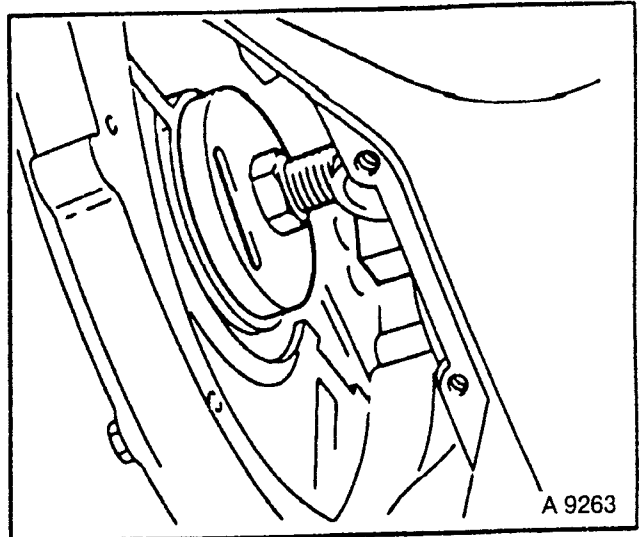


Fig. 113

### INSTALL, CONNECT

1. Seal ring to stop on cylinder block — retaining plate, hex bolt  
1,4 ltr. engine: KM-469-11-A, KM-469-12-A  
1,8/2,0 ltr. engine: KM-469-12-A, KM-511-11.

**NOTE:**  
INSERT LOCATING PINS INTO HOLES ON TRANSMISSION.  
REMOVE ASSEMBLY.

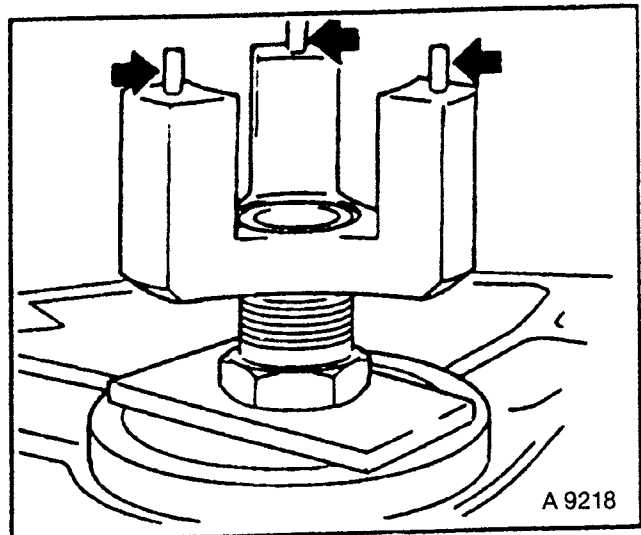


Fig. 114

### TIGHTEN (TORQUE)

1. Guide sleeve for thrust bearing to transmission — 22 Nm (bolt M8).

### INSTALL, CONNECT

1. Flywheel.
2. Clutch.
3. Thrust bearing.

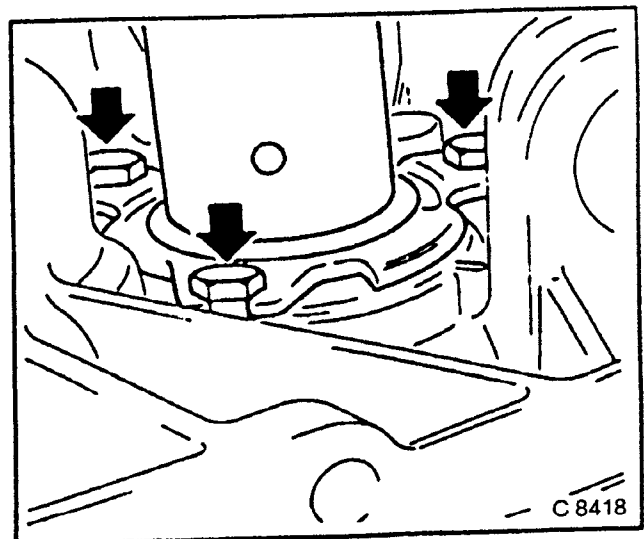


Fig. 115

## Piston with Con-rod — Remove and Install (Engine Installed)

### REMOVE, DISCONNECT

1. Cylinder head, oil pan.
2. Piston with con-rod.  
Mark con-rod bearing cover.

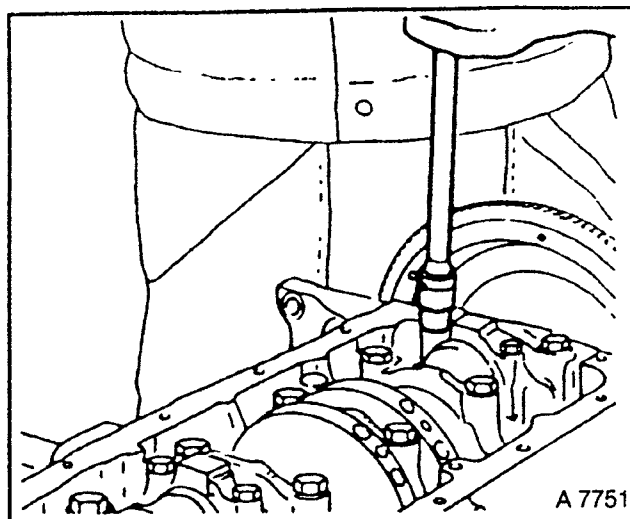


Fig. 116

### INSPECT

1. Replace all parts, if necessary.

### NOTE:

Ring gap offset:

1. Piston rings — 180°.
2. Oil scraper rings — 25 to 50 mm from gap of intermediate ring to the left and to the right.

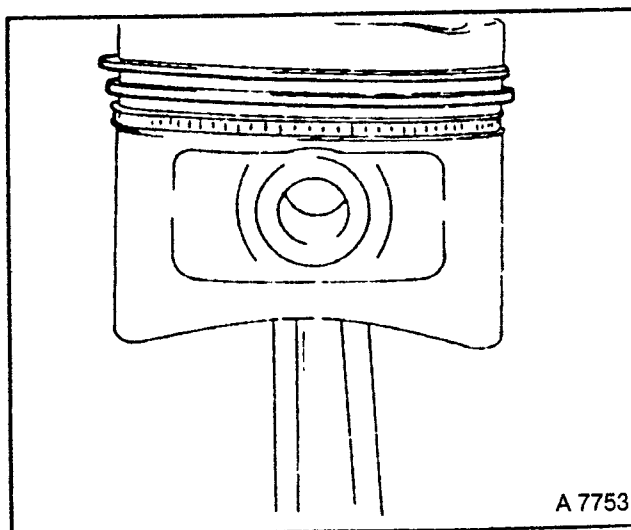


Fig. 117

### INSTALL, CONNECT

1. Piston with con-rod. Insert with engine oil.

### NOTE:

**INSTALLATION POSITION:  
ARROW/NOTCH ON PISTON HEAD  
TO TIMING SIDE OF ENGINE. BEADS  
ON CON-ROD TO CLUTCH SIDE.**

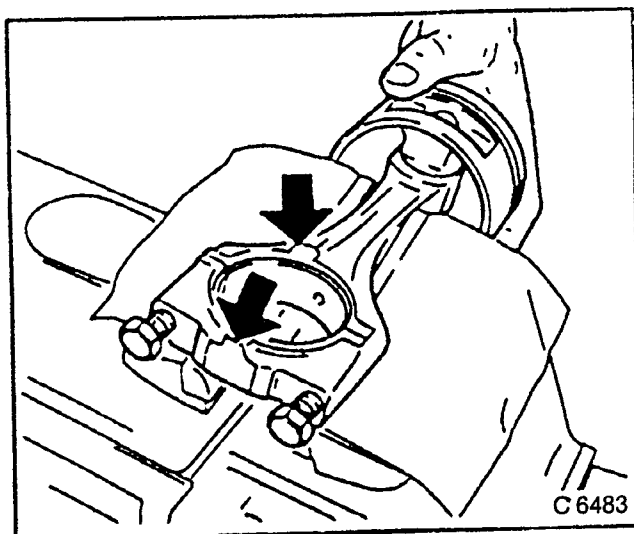


Fig. 118

## TORQUE — ANGLE METHOD

1. Con-rod bearing cover to con-rod — See Recommended Torque Values, page 50.
2. Install oil pan and cylinder head.

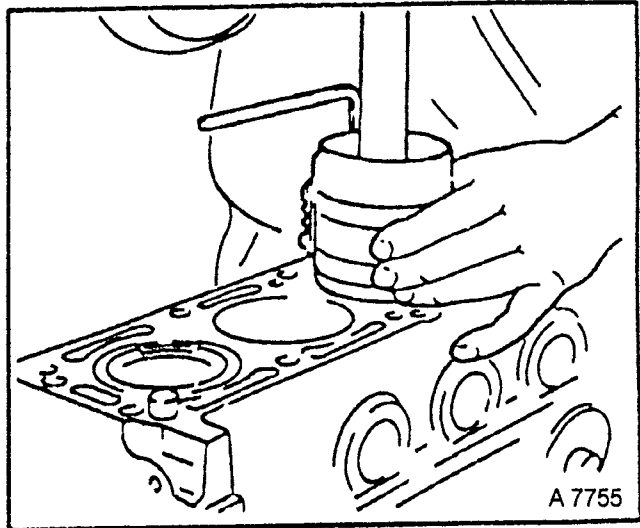


Fig. 119

## Piston Rings — Replace

### REMOVE, DISCONNECT

1. Piston with con-rod.
2. Piston rings — commercially available piston ring clamp pliers.

### CLEAN

1. Piston ring grooves — ground piece of old piston ring.

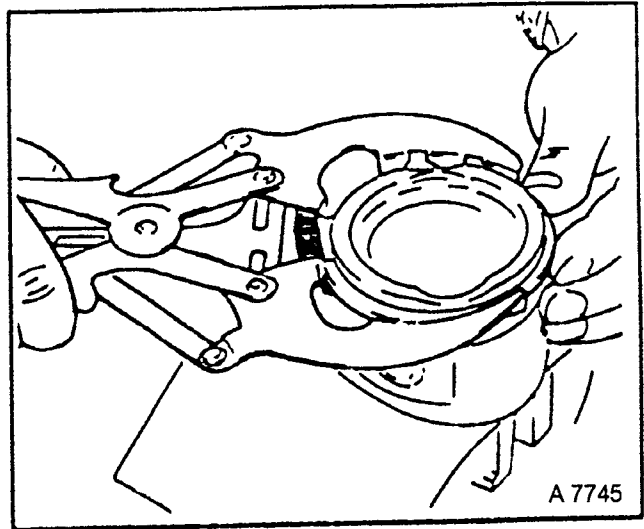


Fig. 120

### INSPECT

1. Piston ring gap.  
For piston ring sizes, permissible piston ring gaps — see "Technical Data", page 312.

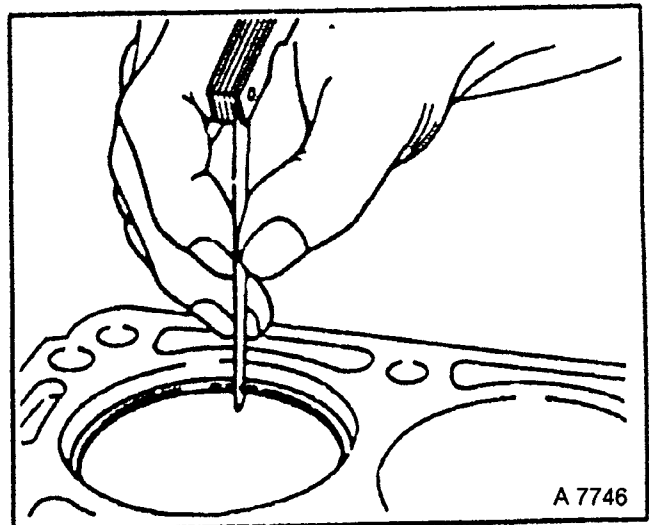


Fig. 121



**INSTALL, CONNECT**

1. Oil scraper ring.
2. Offset ring gaps of steel band rings each 25 to 50 mm to the left or right of the intermediate ring gap.
3. Piston rings.
4. Offset ring gaps by approximately 180°.
5. Second piston ring with identification mark "TOP" facing upwards.
6. Piston with con-rod.

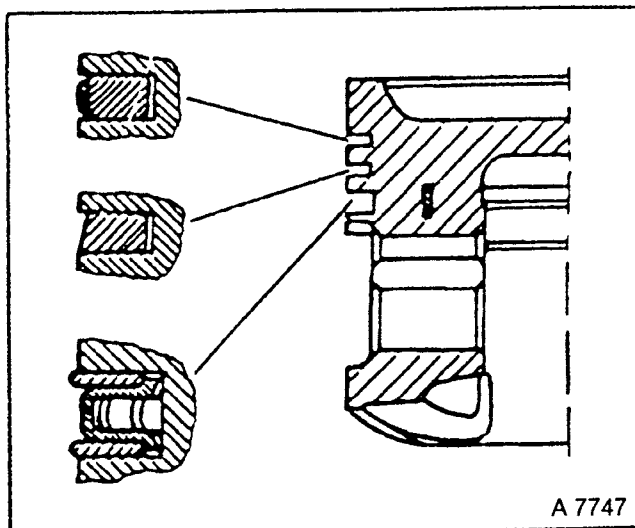


Fig. 122

**Engine Block —  
Check for Plane Surface**

**CLEAN**

1. Cylinder block sealing surfaces.

**INSPECT**

1. Cylinder block sealing surfaces' length and breadth for bending and also the diagonals for warping. Use aligning ruler and feeler gauge.

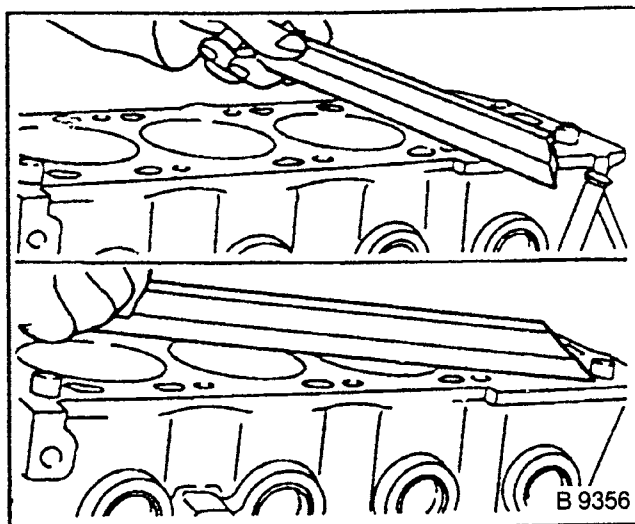


Fig. 123

**NOTE:**

**AFTER SURFACE GRINDING,  
CHECK PISTON PROJECTION. See  
Technical Data PAGE 312.**

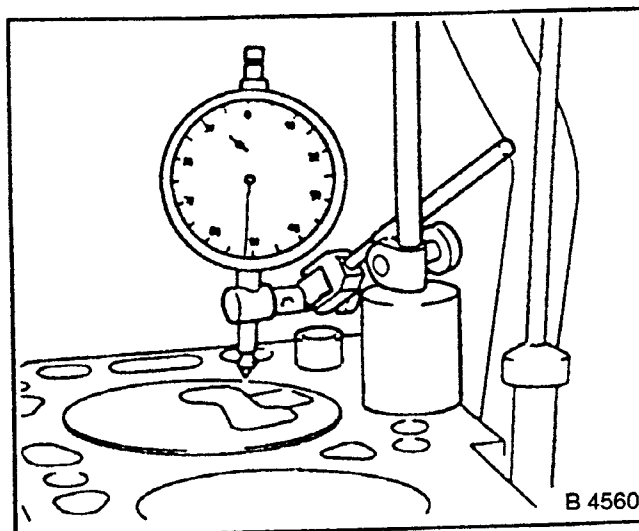


Fig. 124

## Con-rod Bearing — Replace

### REMOVE, DISCONNECT

1. Oil pan.
2. Con-rod bearing cover. Mark con-rod bearing.

### CLEAN

1. Con-rod journal.
2. Con-rod bearing cover.

### INSTALL, CONNECT

1. New bearing shells — (Insert with engine oil).
2. Con-rod bearing cover.

### TORQUE — ANGLE METHOD

1. Con-rod bearing cover to con-rod — See Recommended Torque Values, page 50.
2. Oil pan.

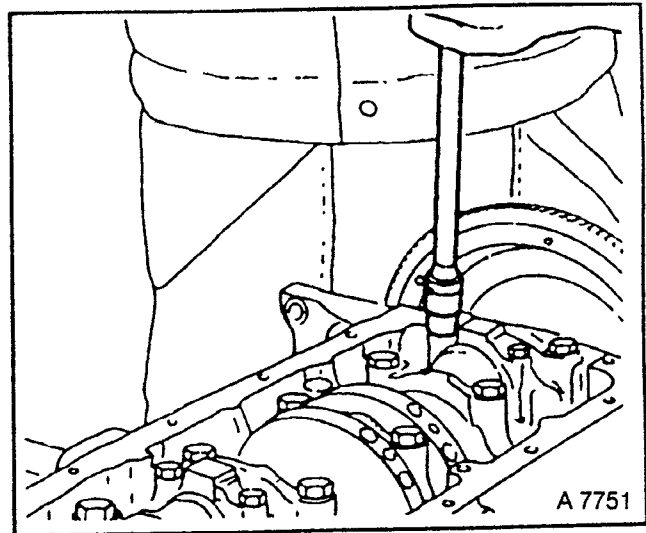


Fig. 125

## Con-rod — Replace

### REMOVE, DISCONNECT

1. Piston with con-rod.

### DISASSEMBLE

1. Con-rod piston assembly.
2. Press out piston bolts:  
1,6 ltr. engine: KM-634-6.  
1,8/2,0 ltr. engine: KM-634-3

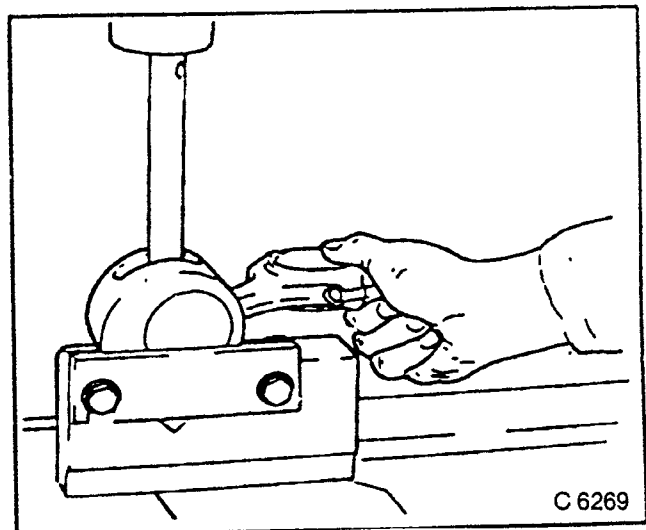


Fig. 126

### ASSEMBLE

1. Guide drift:  
1,6 ltr. engine: KM-634-3, KM-634-5 and KM-634-4.  
1,8/2,0 ltr. engine: KM-634-6, KM-634-8 and KM-634-7.  
  
1,6 ltr. engine: Place KM-634-9 on right slanted side. Align con-rod with piston — observe installation position.
2. Slide guide drift in horizontal position through piston and con-rod as far as side plate stop.
3. Tighten bolts evenly. Piston must rest flush on the rear plate.
4. Remove centre piece from guide drift.
5. Insert piston pins (lubricated) into guide drift.

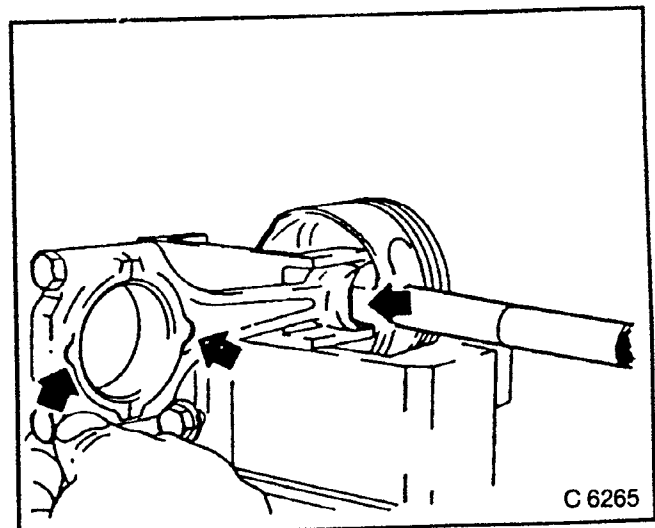


Fig. 127

6. Coat con-rod eye and upper part of con-rod stem with colour — commercially available thermocolour pencil. When the required installation temperature is reached, the green colour changes to black. The colour marking must not change colour over its whole length but only up to the beginning of the con-rod stem.

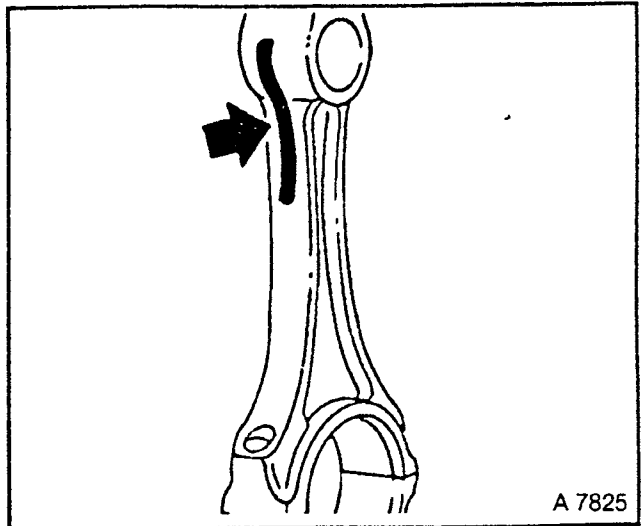


Fig. 128

7. Heat new con-rod with hotplate at upper con-rod eye. Installation temperature: 280°C/536°F to max. 320°C/608°F.
8. Rest eye surface evenly on the hotplate and reduce heat conduction with incombustible firebrick.

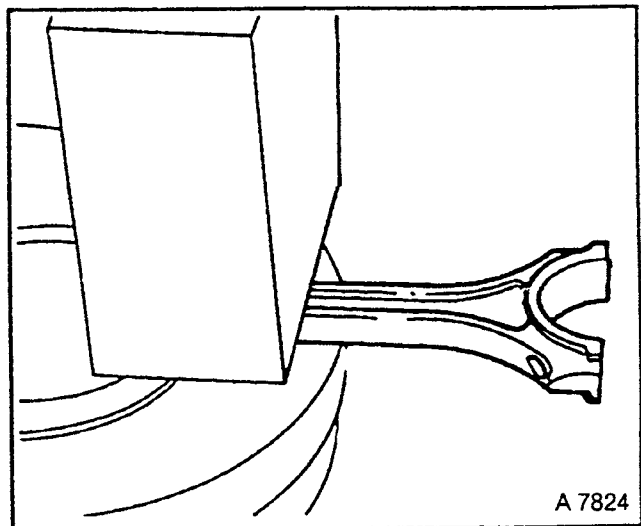


Fig. 129

**NOTE:**

1. Since the con-rods have no counterweights, re-working is not possible. Exchange con-rods in sets only.
2. Installation position: beads on con-rod point to the flattening on the piston pin eye.

**NOTE:**

Firmly seated piston pin can **NOT** be pushed in. Carry out installation quickly.

**ASSEMBLE**

1. Con-rod.
2. Piston pin.
3. Piston.
4. Push in guide drift with piston pin as far as stop into piston.

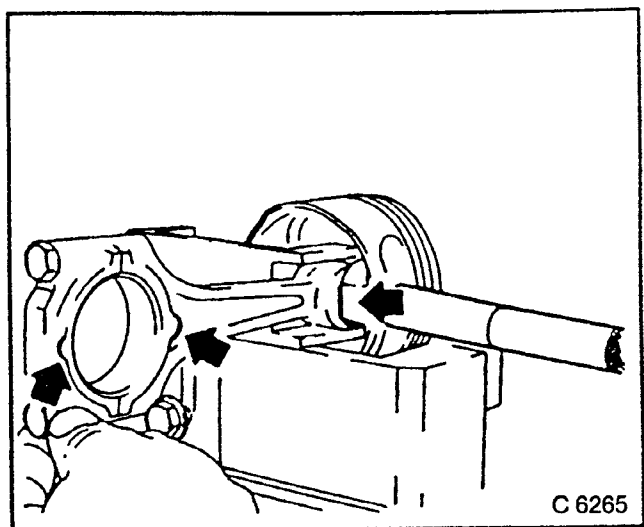


Fig. 130

**INSTALL, CONNECT**

1. Piston with con-rod.

## Crankshaft — Remove and Install

1. Mount engine on Engine Overhaul Stand KM-412 with appropriate adaptors.
2. Drain engine oil — place collecting pan underneath.

### REMOVE, DISCONNECT

1. Attaching aggregates.
2. Flywheel/drive disc.
3. Oil pan.
4. Oil pump.
5. Mark con-rod bearing cover.
6. Crankshaft bearing cover.

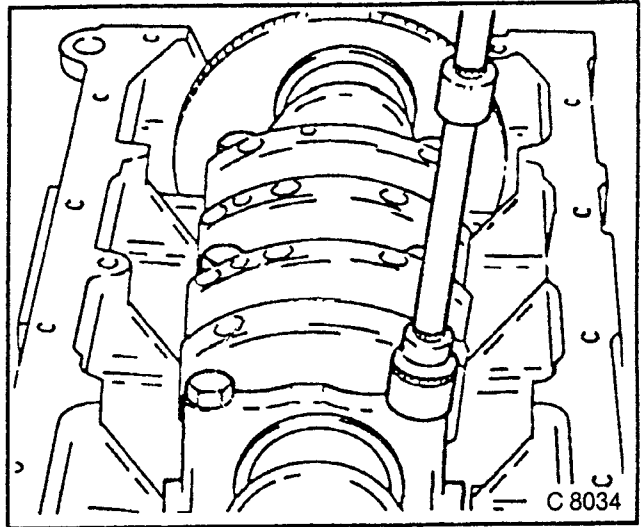


Fig. 131

### REMOVE, DISCONNECT

1. Crankshaft from cylinder block.

### CLEAN

### INSPECT

1. Crankshaft.
2. Replace all parts if necessary.
3. Modify pulse sensor disc when replacing crankshaft — if present.

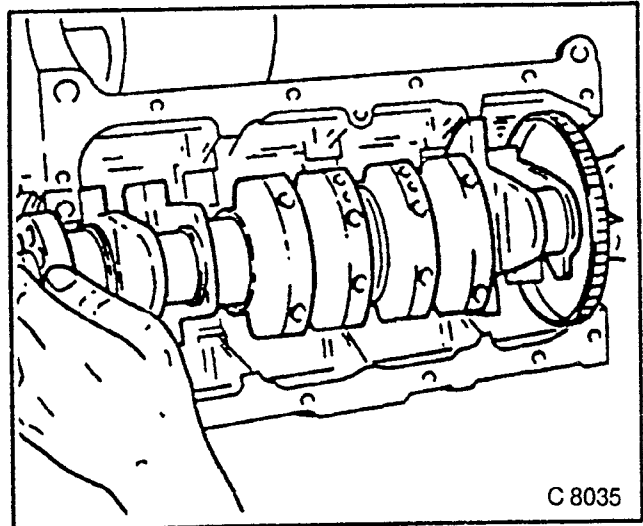


Fig. 132

### INSTALL, CONNECT

1. New bearing shells into cylinder block and bearing cover.
2. Coat bearing shells with engine oil. For oversizes of bearing shells see "Technical Data", page 312.

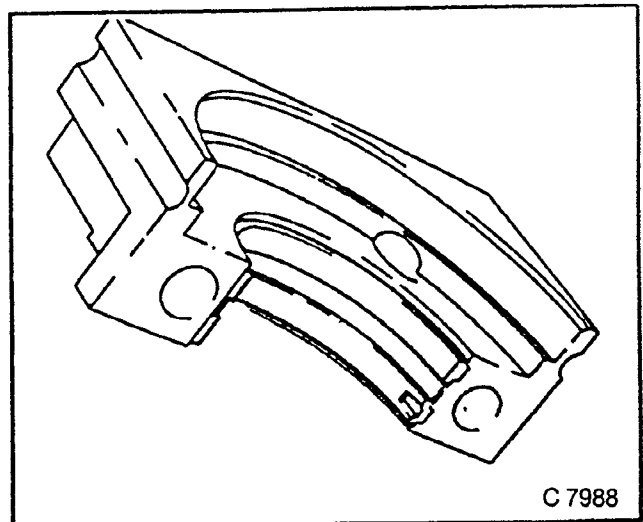


Fig. 133

**INSTALL, CONNECT**

1. New crankshaft into cylinder block.
2. The seating of the crankshaft can be corrected by light blows with a rubber hammer on the crank arm (arrow).

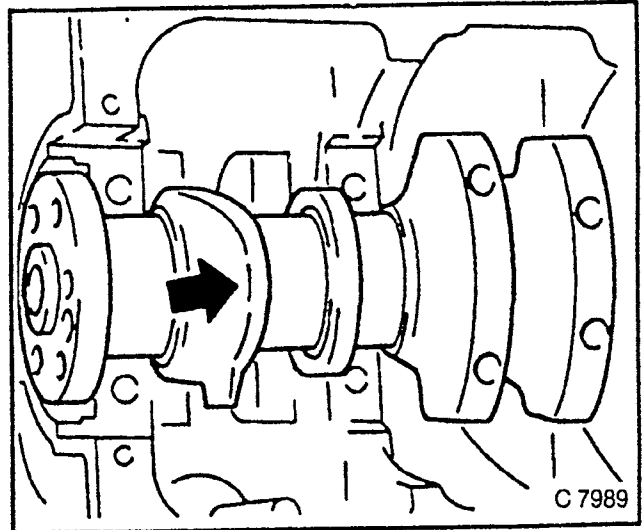


Fig. 134

**INSTALL, CONNECT**

1. Bearing front and rear covers — coat inner surfaces with Sealing Compound Locktite 515 flexible gasket or equivalent.

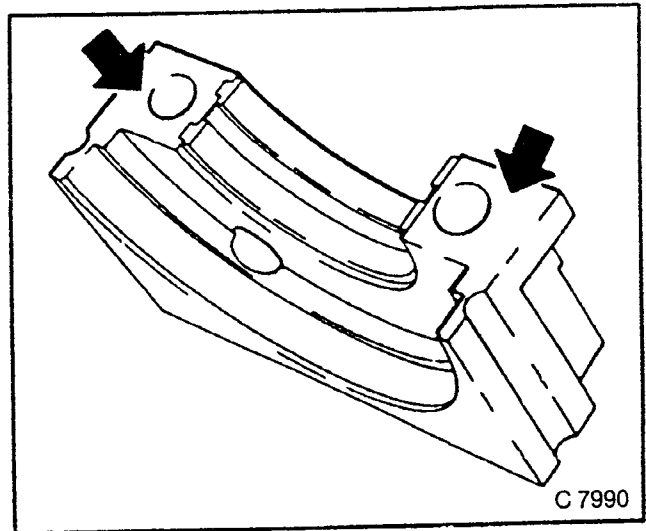


Fig. 135

2. Apply a bead of Adhesive Sealing Compound Locktite 242 in the grooves of the two bearing covers.

**NOTE:**

1. Camshaft housing cover.
2. After installation, press in adhesive sealing compound from above again until it emerges from the bearing cover joints.

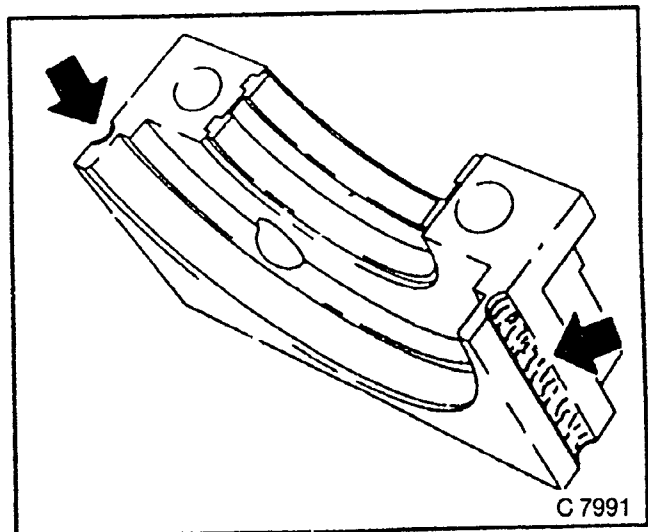


Fig. 136

## TORQUE — ANGLE METHOD

1. Crankshaft bearing cover to cylinder block.
2. Con-rod bearing cover to con-rod — see Recommended Torque Values, page 50.
3. Align bearing front cover to engine fore part.

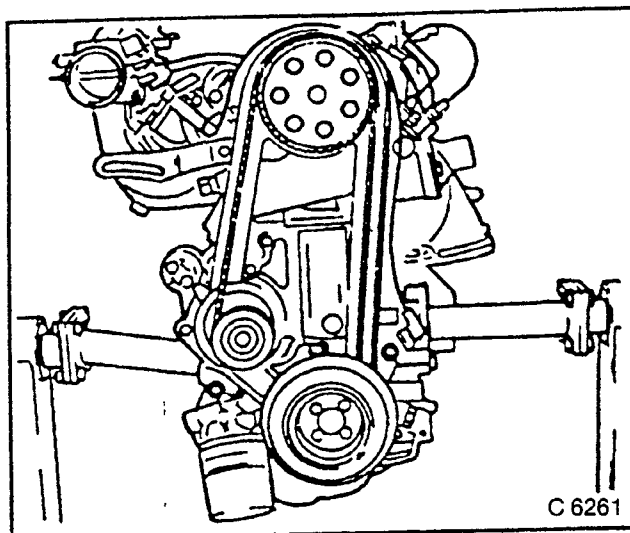


Fig. 137

## INSTALL, CONNECT

1. Oil pump.
2. Oil pan.
3. Crankshaft rear seal ring.
4. Flywheel/drive disc.  
Attaching aggregates.

### NOTE:

1. Before installation of toothed belt, check timing.
2. Engine from Engine Stand KM-412.
3. Adapter from engine.
4. Install engine.

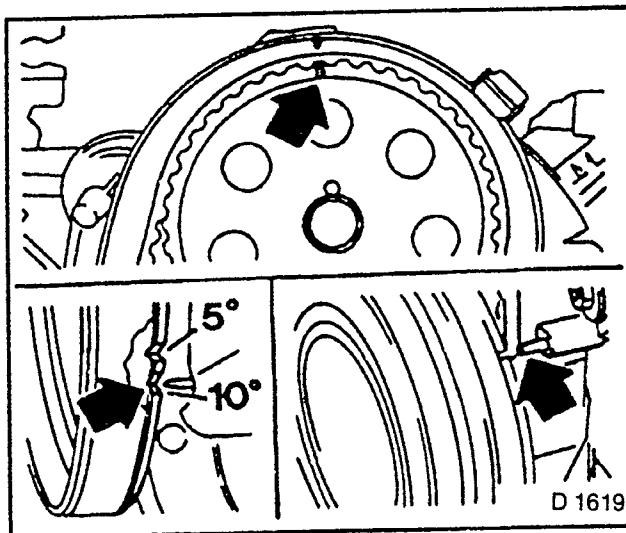


Fig. 138

## Crankshaft — Check

### INSPECT

1. End play — bearing shells installed.
2. Front end contact surfaces of flywheel/drive disc.  
Permissible end play — see Technical Data, page 312.

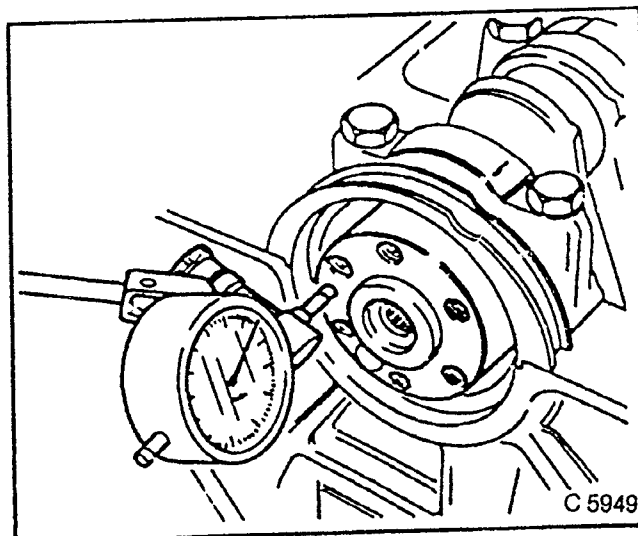


Fig. 139

**INSPECT**

1. Out-of-round (run-out) — middle bearing shell removed.  
When mounted on front and rear bearing.  
Permissible out-of-round. See Technical Data, page 312.

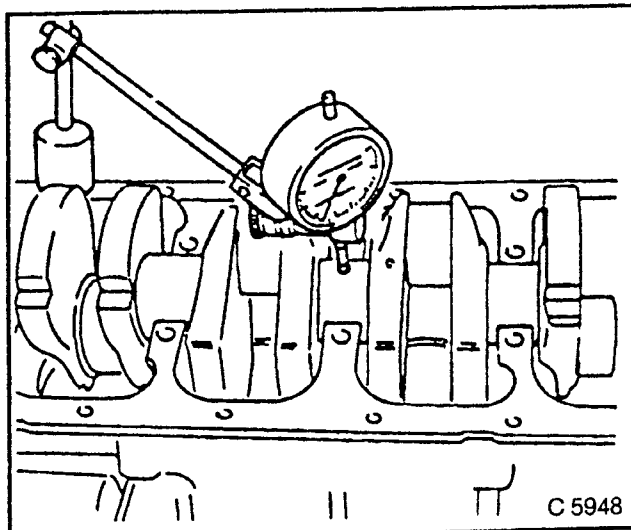


Fig. 140

**INSPECT**

1. Bearing play — bearing cover removed.

**MEASURE**

With "Plastigage" (ductile plastic threads).

1. Cut threads to length of bearing width and lay axially between crankshaft journal and bearing shell (arrow).
2. Install bearing cover with correct torque — see "Recommended Torque Values", page 50.

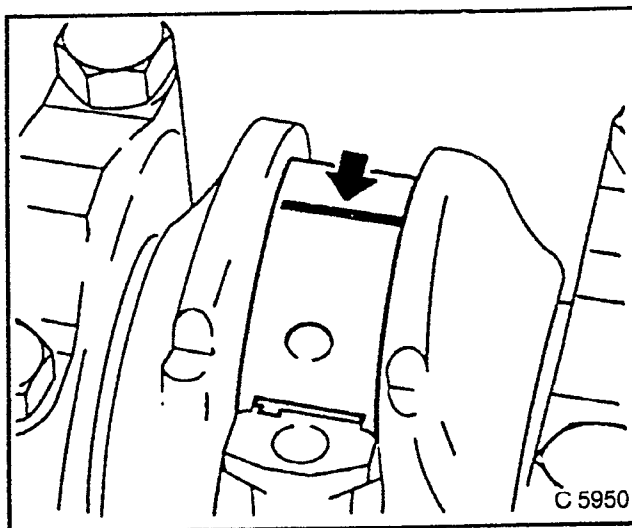


Fig. 141

**NOTE:**

1. Remove grease from crankshaft journal.
2. Lubricate bearing shell slightly so that the thread does not tear when the bearing cover is removed.

**REMOVE, DISCONNECT**

1. Bearing cover.

**MEASURE**

1. Width of compressed plastic thread (arrow). Compare with measuring scale.

"Plastigage" is available for varying tolerance ranges.  
Type: PG-1, colour: green.

Permissible tolerance ranges — see Technical Data, page 312.

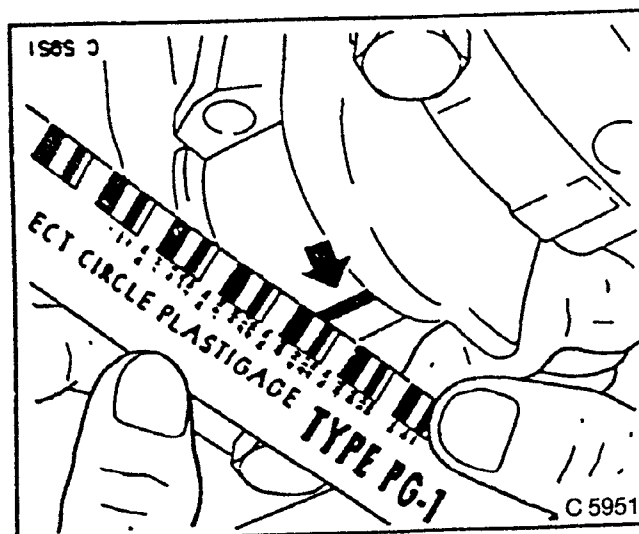


Fig. 142

**TORQUE — ANGLE METHOD**

1. Bearing cover to cylinder block — see Recommended Torque Values, page 50.

## Flywheel — Remove and Install (1,6 ltr. Engine)

### REMOVE, DISCONNECT

1. Transmission.
2. Clutch — see corresponding operations in Section K.
3. Flywheel — lock with KM-652.

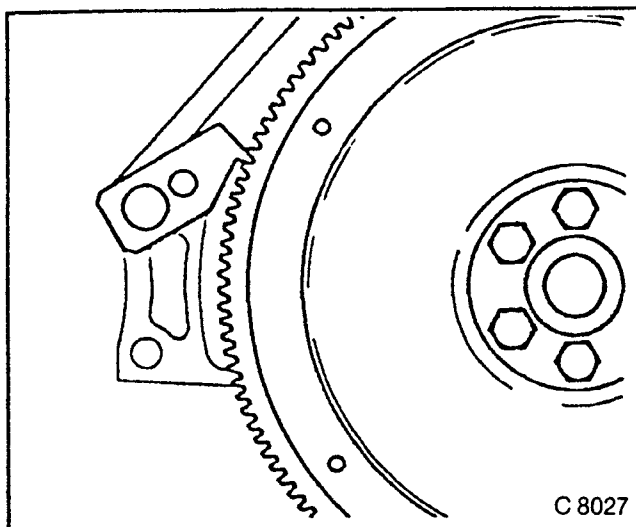


Fig. 143

### TORQUE — ANGLE METHOD

1. Flywheel to crankshaft — 35 Nm + 30° to 15°  
Use new bolts.

### INSTALL, CONNECT

1. Clutch.
2. Transmission — see corresponding operations in Section K.

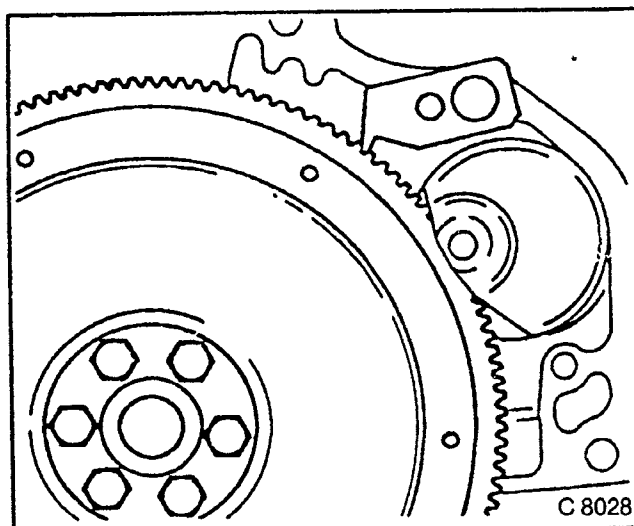


Fig. 144

## Flywheel — Remove and Install (except for 1,6 ltr. Engine)

### REMOVE, DISCONNECT

1. Clutch.
2. Thrust bearing.
3. Guide sleeve for thrust bearing.  
See corresponding operations in Section K.
4. Flywheel — lock with KM-517.  
Mark installation position.

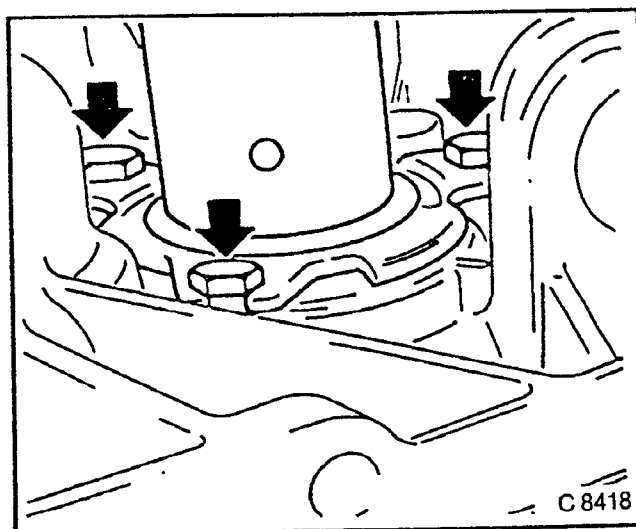


Fig. 145



**TIGHTEN (TORQUE)**

Engine	1,4 ltr.	1,8/2,0 ltr.
1. Flywheel to crankshaft	35 Nm + 30° to 15°**)	65 Nm + 30° to 15°**)
2. Guide sleeve for thrust bearing to transmission housing	22 Nm	22 Nm

\*) Use new bolts.

\*\*\*) Insert bolts with Locking Compound Loctite 242

3. Install guide sleeve, thrust bearing, clutch.

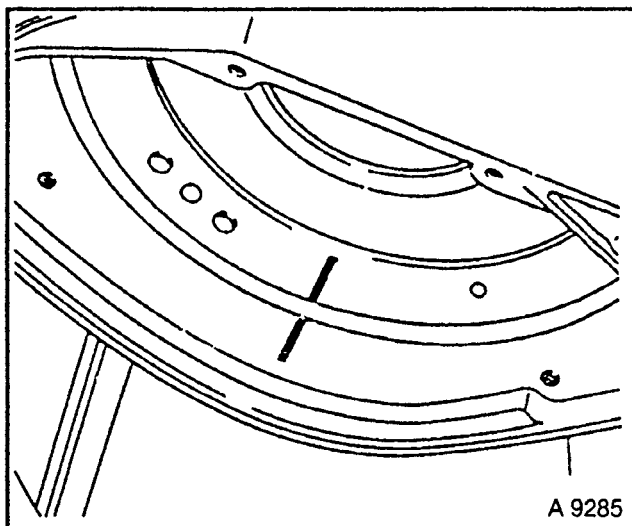


Fig. 146

**Recommended Torque Values — Oil Circuit**

	Nm
Bracket for oil intake pipe to cylinder block	6 <sup>2)</sup>
Bracket for oil intake pipe to cylinder block	8 <sup>1)3)</sup>
Oil drain plug to oil pan	45 <sup>2)</sup>
Oil drain plug to oil pan	55 <sup>1)</sup>
Oil filter cartridge to connection fitting (cylinder block)	15 <sup>1)</sup>
Oil filter cartridge to oil pump	15 <sup>2)</sup>
Oil intake pipe to oil pump	8 <sup>3)</sup>
Oil pressure switch/sensor to oil pump	30 <sup>1)</sup>
Oil pressure switch/sensor to oil pump	40 <sup>2)</sup>
Oil pump to cylinder block	6
Screw plug for pressure relief valve to oil pump	30

<sup>1)</sup> 1,4 / 1,6 ltr. engine

<sup>2)</sup> 1,8 / 2,0 ltr. engine

<sup>3)</sup> Bolt must be recut before reusing and installed using Locking Compound (Loctite 242).

**Oil Filter Cartridge — Replace**

**REMOVE, DISCONNECT**

1. Oil filter cartridge — commercially available tool.

**INSTALL, CONNECT**

1. Oil filter cartridge by hand — oil seal ring.
2. Fill up engine oil.

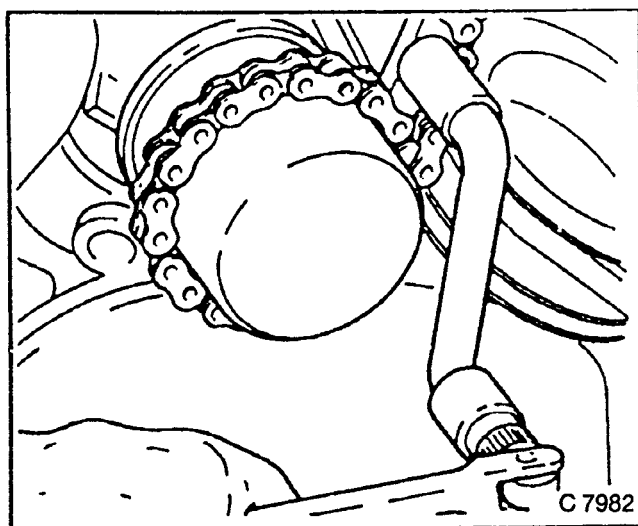


Fig. 147

## Bypass Valve — Replace

Oil filter removed.

### REMOVE, DISCONNECT

1. Bypass valve.
2. Cut thread in locking disc with M 10 tap (3rd stage).
3. Turn in M 10 bolt.
4. Take out bypass valve from seating.

### INSTALL, CONNECT

1. Bypass valve — with drift ( $\varnothing$  approximately 15 mm) until it rests.

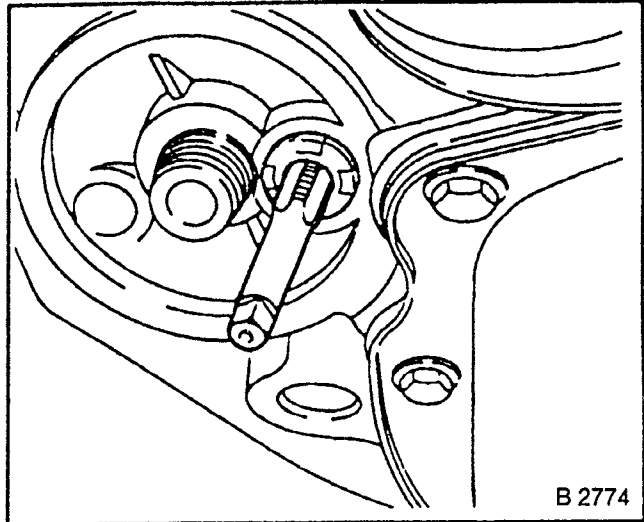


Fig. 148

## Oil Pump — Remove and Install

### REMOVE, DISCONNECT

1. Rear toothed belt cover.
2. Oil pan.
3. Oil pump intake pipe from oil pump.
4. Oil filter cartridge.
5. Plug from oil pressure switch/sensor.
6. Oil pump from cylinder block.
7. Oil pressure switch/sensor from oil pump.

### CLEAN

1. Sealing surfaces.

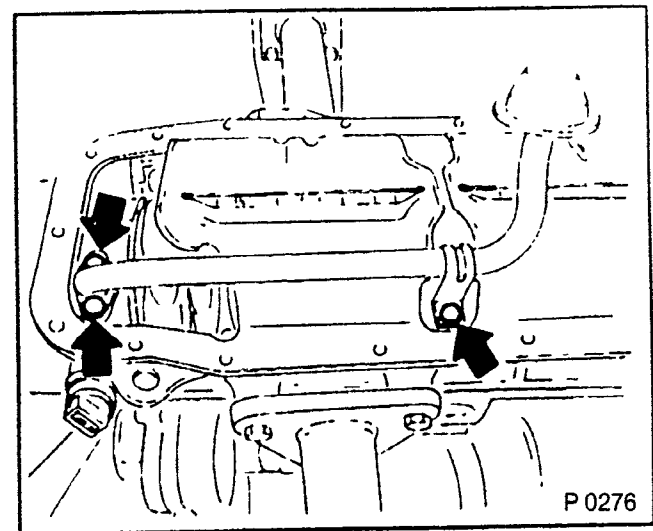


Fig. 149

### INSTALL, CONNECT

1. Oil pressure switch/sensor to oil pump.
2. Oil pump to cylinder block.
3. Oil pump intake pipe.
4. Oil pan.
5. Wiring harness plug.
6. Oil filter cartridge.
7. Toothed belt cover.
8. Toothed belt — see operation.

### TIGHTEN (TORQUE)

1. Oil pressure switch/sensor to oil pump — 40 Nm\*.
  2. Oil pump to cylinder block — 6 Nm.
  3. Oil intake pipe to oil pump — 8 Nm\*\*.
- \* 1,4 and 1,6 ltr. 30 Nm.  
 \*\* Insert bolts with Locking Compound (Loctite 242).

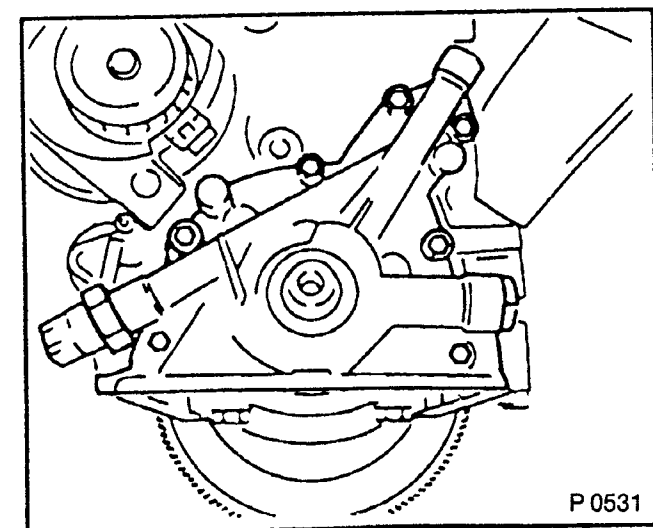


Fig. 150

## Oil Pump — Check

### REMOVE, DISCONNECT

1. Oil pump.
2. Oil pump cover.
3. Pressure relief valve.

### INSPECT

1. Recess of pair of toothed gears.  
1,4 / 1,6 ltr.: 0,08 to 0,15 mm.  
1,8 / 2,0 ltr.: 0,03 to 0,1 mm
2. Check housing.
3. Oil pump cover.
4. Pressure relief valve for signs of wear.

### INSTALL, CONNECT

1. Oil pump cover with Sealing Compound (Loctite 242).
2. Pressure relief valve with new copper sealing ring.
3. Oil pump with new sealing ring.

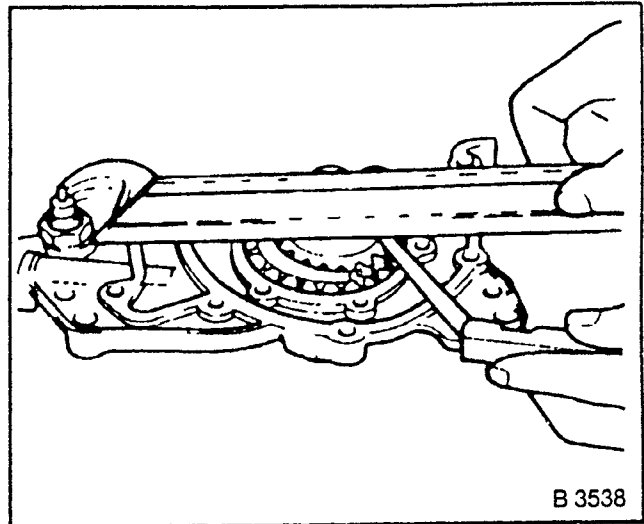


Fig. 151

## Oil Pump Safety Valve — Replace

### REMOVE, DISCONNECT

1. Closure plug.
2. Seal ring.
3. Spring.
4. Piston.

Fig. 152 shows C 16 NZ engine.

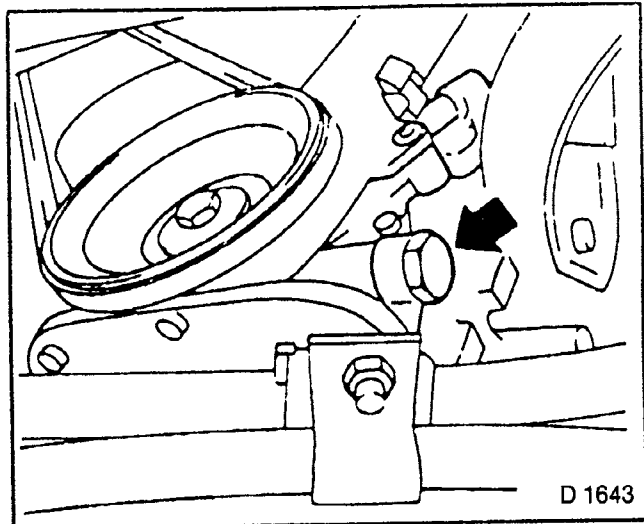


Fig. 152

### INSTALL, CONNECT

1. Piston (observe installation position).
2. Spring.
3. Seal ring.
4. Closure plug.

### TIGHTEN (TORQUE)

1. Closure plug to oil pump — 30 Nm.

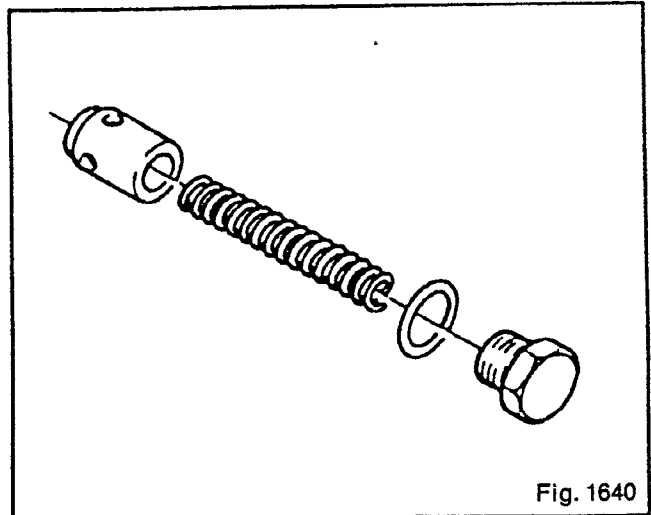


Fig. 153

Fig. 1640

## COOLING SYSTEM

### Recommended Torque Values

	Nm
Camshaft housing cover to housing .....	8
Camshaft sprocket to camshaft .....	45
Rear toothed belt cover to camshaft housing .....	12 <sup>1)</sup>
Temperature sensor to intake manifold .....	10
Thermostat housing to cylinder head .....	10 <sup>1)</sup>
Thermostat housing to cylinder head .....	15 <sup>2)</sup>
Water outlet fitting to thermostat housing .....	8
Water pump to cylinder block (M 6) .....	8 <sup>1)</sup>
Water pump to cylinder block (M 8) .....	25 <sup>2)</sup>

<sup>1)</sup> 1,4 / 1,6 ltr. engine

<sup>2)</sup> 1,8 / 2,0 ltr. engine

## Radiator — Remove and Install

### REMOVE, DISCONNECT

1. Ground cable from battery.
  2. Coolant hoses — collect coolant.
- AT:
- Fluid lines from radiator — close openings.
  - Wiring harness plug (1) from fan motor.

### REMOVE, DISCONNECT

1. Coolant hose.
2. Wiring harness plug from temperature sensor.
3. Retaining bracket (1).
4. Radiator — if necessary, first fan shroud with fan motor.
5. When replacing, transfer attaching parts.

### INSTALL, CONNECT

1. Radiator.
2. Retaining bracket.
3. If disconnected: fan shroud with fan motor to radiator.
4. Coolant hoses to radiator.

### INSTALL, CONNECT

1. Wiring harness plug to temperature sensor.
2. Wiring harness plug (1) to fan motor.
3. Ground cable to battery.
4. Top up and bleed cooling system.

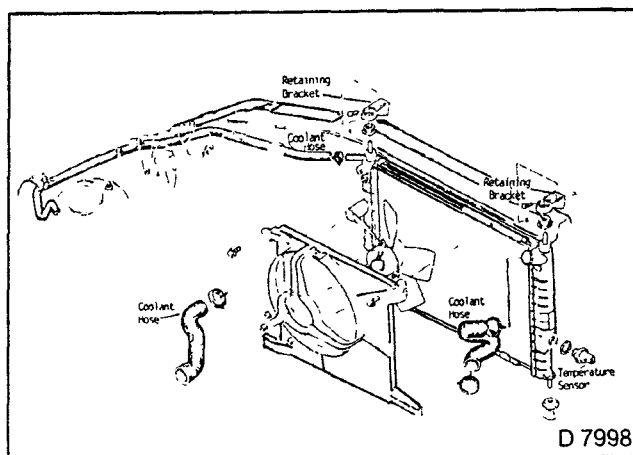


Fig. 154

## Cooling System — Top Up and Bleed

### NOTE:

**RADIATOR AND HEATER CORE ARE MADE OF ALUMINIUM. TO AVOID CORROSION, USE ONLY ANTI-FREEZE WITH CORROSION PROTECTION, SABS 1251**

1,4 / 1,6 ltr. engines:

### REMOVE, DISCONNECT

1. Wiring harness plug.
2. Coolant temperature sensor.
3. Fill with coolant, until it flows out bubble-free from the installation port of the temperature sensor.

### TIGHTEN (TORQUE)

1. Temperature sensor to intake manifold — 10 Nm.
2. Connect wiring plug.

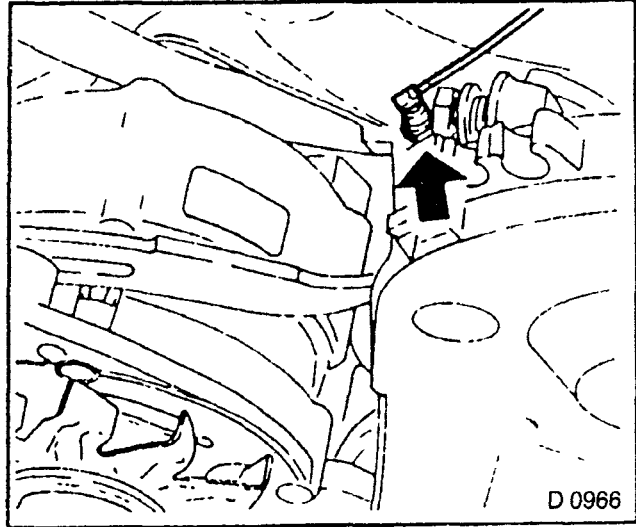


Fig. 155

### ALL ENGINES:

Fill coolant to "KALT" mark on compensation tank.

### NOTE:

**AFTER CLOSING THE COOLING SYSTEM, LET ENGINE RUN WARM UNTIL THERMOSTAT OPENS (COOLANT APPROXIMATELY 92°C/197,6°F).**

### INSPECT

1. Coolant level.
2. Allow engine to cool.
3. If necessary top up coolant to "KALT" mark on compensation tank.

1,8 / 2,0 ltr. engines:

Cooling system bleeds itself during engine warming-up phase.

## Cooling System — Check for leaks

Engine at operating temperature (oil temperature  $\geq 80^{\circ}\text{C}/176^{\circ}\text{F}$ ).  
Check coolant level.

KM-471 and commercially available radiator checking instrument onto compensation tank (observe manufacturer's instructions). Apply approximately 100 kPa (1 bar/14,5 psi) pressure to cooling system.

### INSPECT

1. Cooling system for leaks.
2. Remove tester.
3. Close compensation tank.

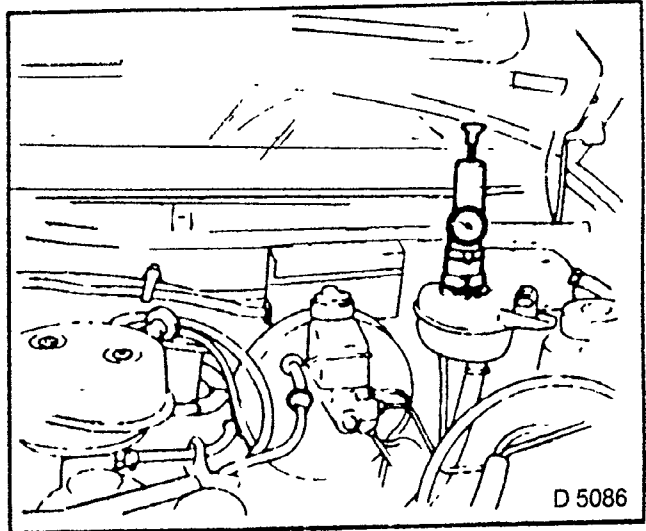


Fig. 156

## Coolant Temperature — Measure with Closed Cooling System

### INSTALL, CONNECT

Temperature Gauge 17 57 230 (90 141 985) in heating hose.  
Follow manufacturer's instructions.

### MEASURE

1. Coolant temperature — operating temperature approximately  $80^{\circ}\text{C}/176^{\circ}\text{F}$

### REMOVE, DISCONNECT

1. Temperature gauge.

### INSTALL, CONNECT

1. Heating hose.
2. Bleed cooling system.

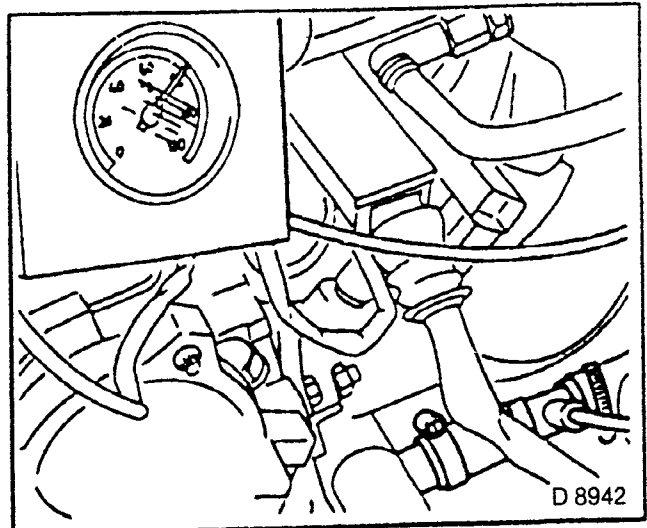


Fig. 157

## Fan Motor — Replace

### REMOVE, DISCONNECT

1. Ground cable from battery.
2. Wiring harness plug from fan motor.
3. Fan shroud with fan motor from radiator.

When replacing:  
Fan motor from fan shroud.

### INSTALL, CONNECT

1. Fan shroud with fan motor to radiator.
2. Wiring harness plug to fan motor.
3. Ground cable to battery.

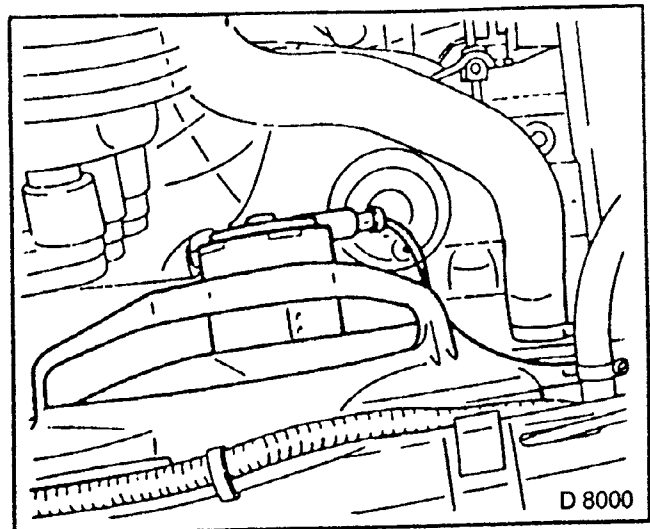


Fig. 158

## Thermostat — Replace (1,4/1,6 ltr.)

### REMOVE, DISCONNECT

1. Lower coolant hose from radiator — collect coolant.
2. Release and remove toothed belt.  
See operation "Toothed Belt, Replace", page 24  
For clearer representation, Fig. 159 shows removed engine.
3. Camshaft housing cover.
4. Camshaft timing gear.
5. Toothed belt rear cover from camshaft housing.

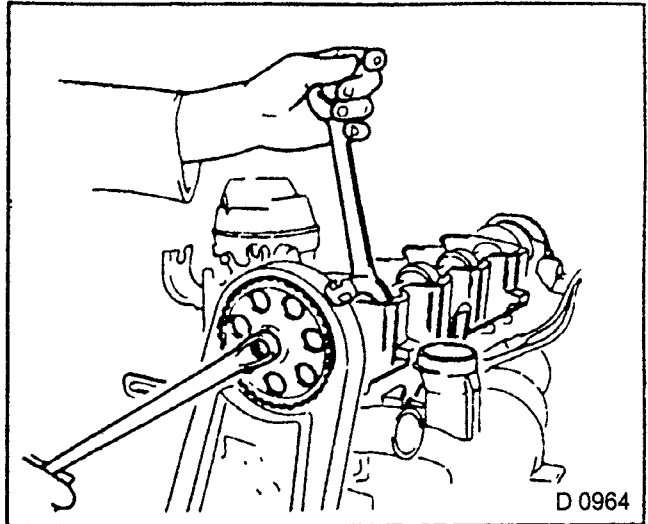


Fig. 159

### REMOVE, DISCONNECT

1. Swing toothed belt rear cover to one side.
2. Thermostat housing from cylinder head.
3. Thermostat.

### CLEAN

1. Sealing surfaces.

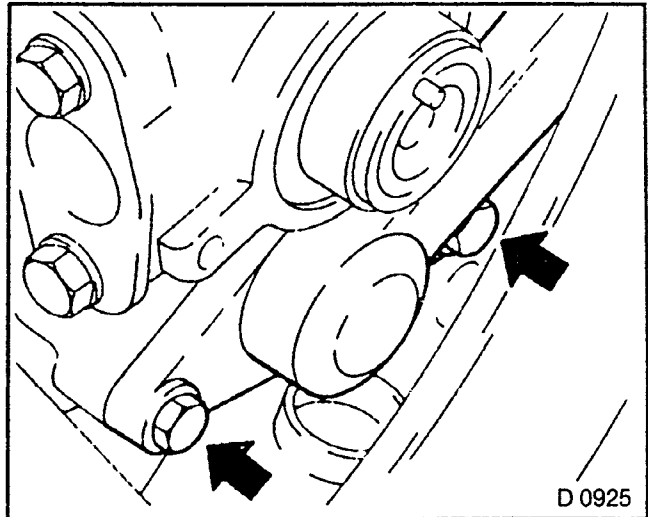


Fig. 160

Insert thermostat with sealing ring — note recess in cylinder head.

### TIGHTEN (TORQUE)

1. Thermostat housing to cylinder head — 10 Nm.
2. Toothed belt rear cover to camshaft housing — 12 Nm.
3. Install coolant hose.

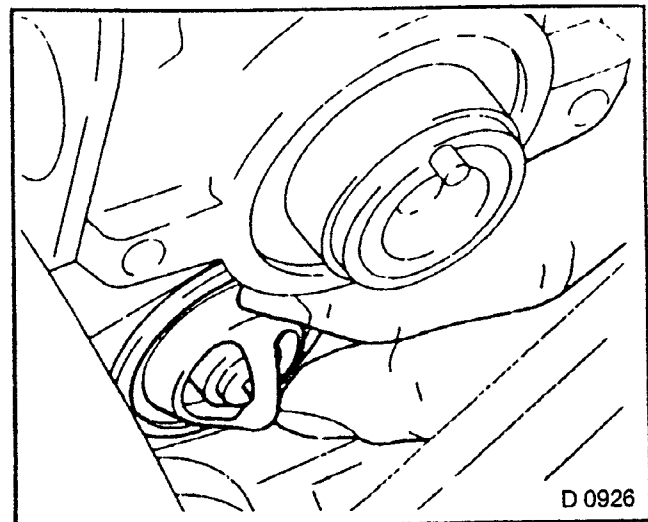


Fig. 161

**TIGHTEN (TORQUE)**

1. Camshaft timing gear to camshaft  
— 45 Nm.
2. Camshaft housing cover to housing  
— 8 Nm.
3. Insert and tension toothed belt.
4. Fill up and bleed cooling system.

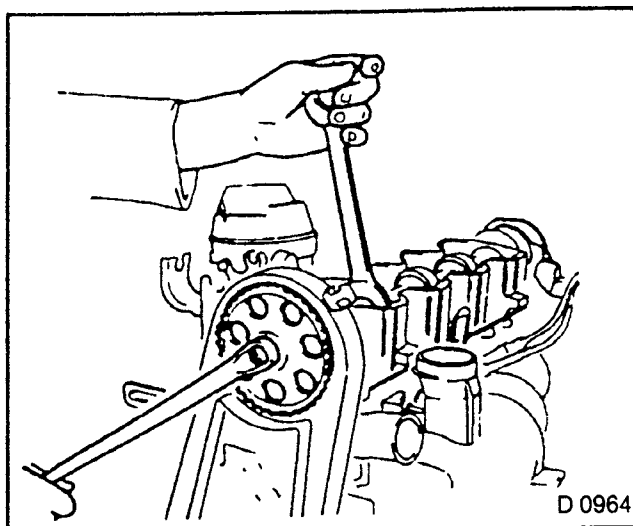


Fig. 162

**Thermostat — Replace  
(1,8/2,0 ltr.)****REMOVE, DISCONNECT**

1. Water outlet nozzle with thermostat from thermostat housing.
2. Coolant hose — collect coolant.

**NOTE:**

**ONLY REPLACE THERMOSTAT TOGETHER WITH WATER OUTLET NOZZLE.**

**TIGHTEN (TORQUE)**

1. Water outlet nozzle to thermostat housing — 8 Nm.

**INSTALL, CONNECT**

1. Coolant hose.
2. Fill and bleed cooling system.

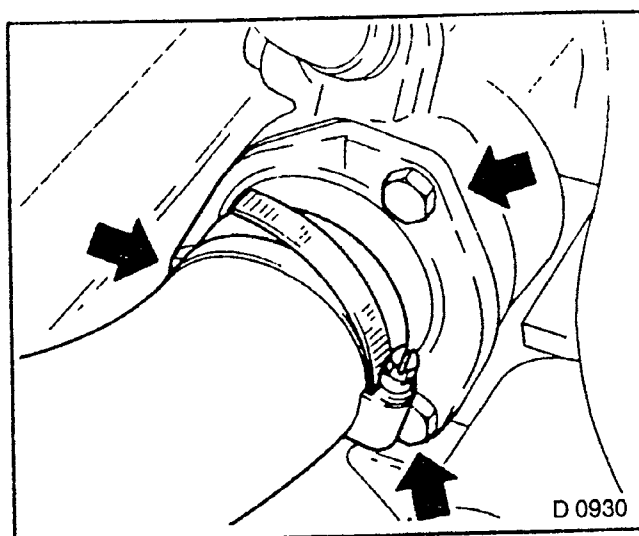


Fig. 163

**Water Pump — Remove  
and Install****REMOVE, DISCONNECT**

1. Lower coolant hose from pipe bend — collect coolant.
2. Front toothed belt cover.
3. Position piston of 1st cylinder to TDC.
4. Position of timing marks — see operation "Timing, Check and Adjust", page 15.
5. Water pump from cylinder block — release tension of toothed belt.

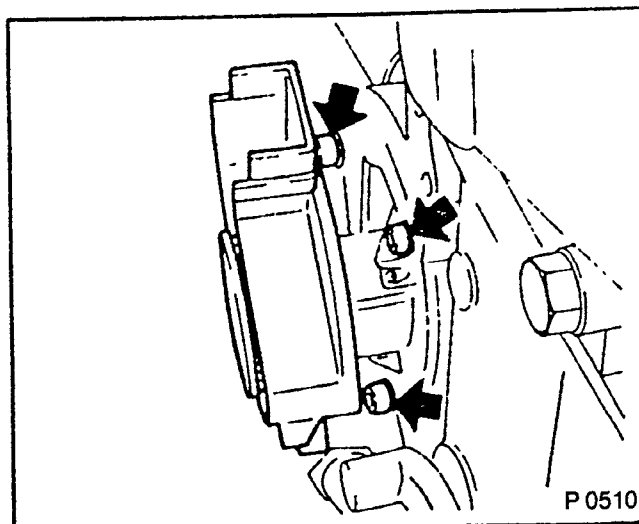


Fig. 164



**CLEAN**

1. Sealing surfaces.
2. Coat sealing surfaces with Silicon Grease B0400571 (Kluber unisilikon TK 572/300).

**INSTALL, CONNECT**

1. Water pump to cylinder block — Use new gasket.
2. Coolant hose.
3. Install toothed belt and tension.
4. Top up cooling system and bleed.

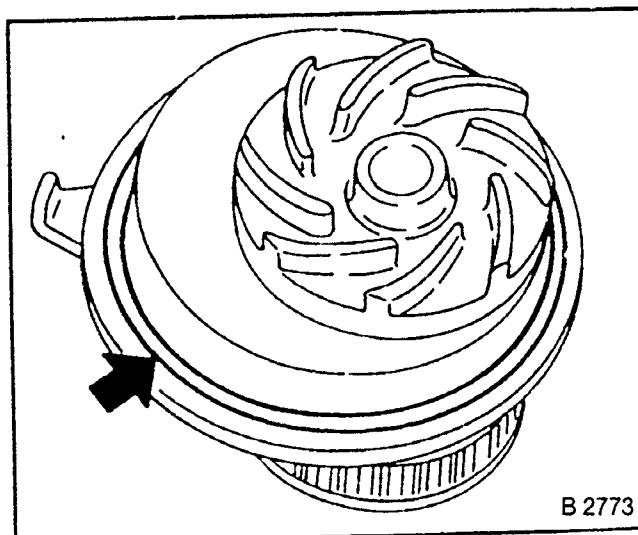
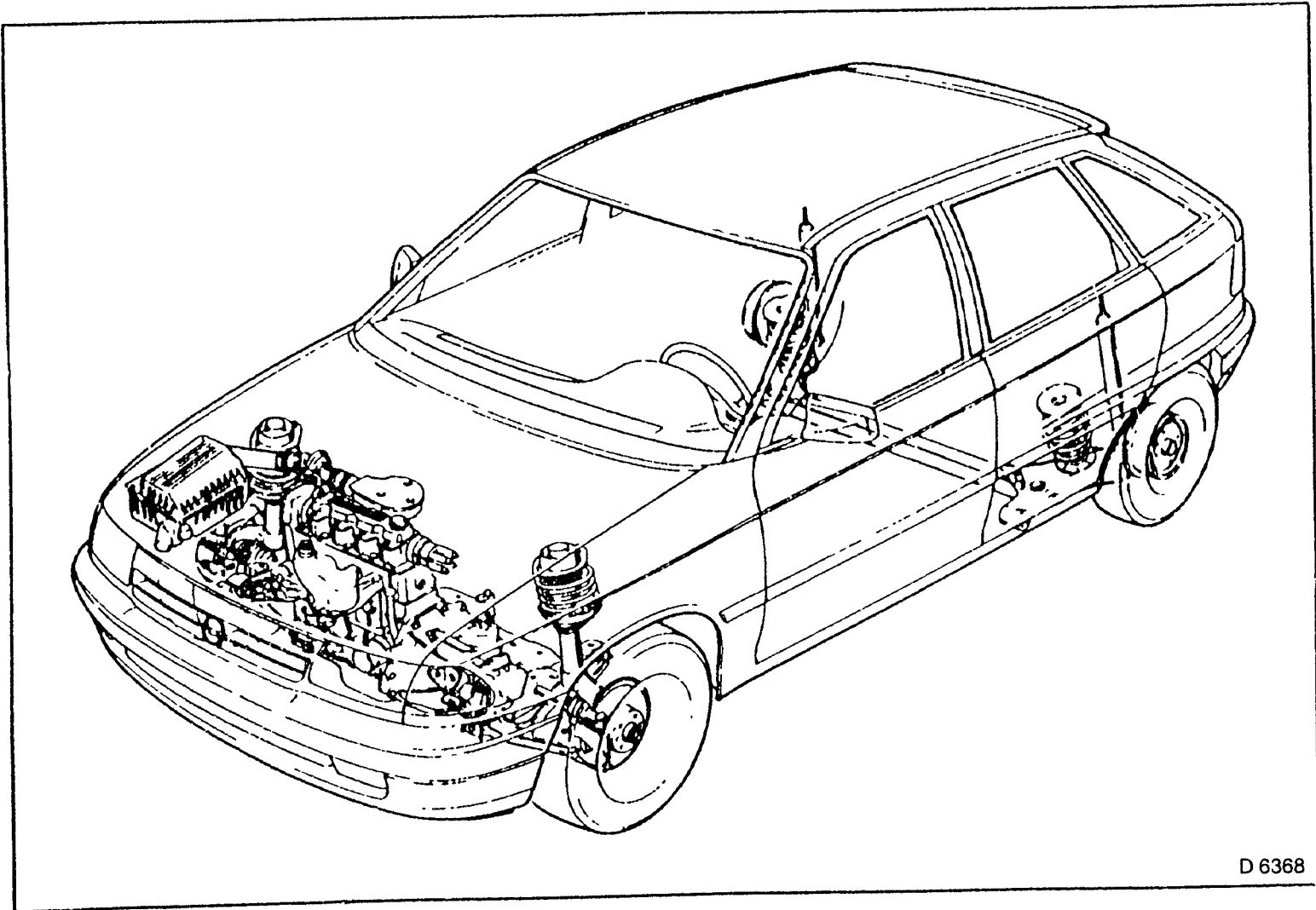


Fig. 165

ENGINE DAMPING BLOCKS, ENGINE, SHORT BLOCK ENGINE



D 6368

Fig. 166

## Recommended Torque Values — Engine Damping Blocks, Short-block

	Nm
Bracket for oil intake pipe to cylinder block . . . . .	6 <sup>2)</sup>
Bracket for oil intake pipe to cylinder block . . . . .	8 <sup>1)</sup>
Cylinder head to cylinder block . . . . .	25 + 60° + 60° + 60° <sup>3)3)3)</sup>
Cylinder head to cylinder block . . . . .	55 + 60° + 60° + 30° <sup>1)3)3)</sup>
Engine suspension bracket to cylinder block . . . . .	60
Oil drain plug to oil pan . . . . .	45 <sup>2)</sup>
Oil drain plug to oil pan . . . . .	55 <sup>1)</sup>
Oil intake pipe to oil pump . . . . .	8 <sup>2)</sup>
Oil pan to cylinder block . . . . .	5 <sup>2)3)3)</sup>
Oil pan to cylinder block . . . . .	8 <sup>1)3)3)</sup>
Power steering pump to engine block . . . . .	30 <sup>4)</sup>
Pulley to power steering pump . . . . .	25 <sup>4)</sup>
Right engine damping block to side member . . . . .	65 <sup>2)</sup>
Starter support to cylinder block . . . . .	25 <sup>2)</sup>
Starter to cylinder block . . . . .	25 <sup>1)</sup>
Starter to cylinder block . . . . .	45 <sup>2)7)</sup>
Transmission to engine . . . . .	75

- 1) 1,4 / 1,6 ltr. engine
- 2) 1,8 / 2,0 ltr. engine
- 3) Bolt must be recut before reusing and inserted using Locking Compound (Loctite 242).
- 4) Only 1,6 ltr with power steering.
- 5) Use new bolts.
- 6) After test run turn a further 30°
- 7) Tighten engine side — transmission side to 75 Nm
- 8) Installation time maximum 10 mins.

### Engine without Transmission — Remove and Install (1,4/1,6 ltr.)

#### REMOVE, DISCONNECT

1. Battery.
2. Bonnet.
3. Lower coolant hose from radiator — collect coolant.
4. Upper coolant hose.

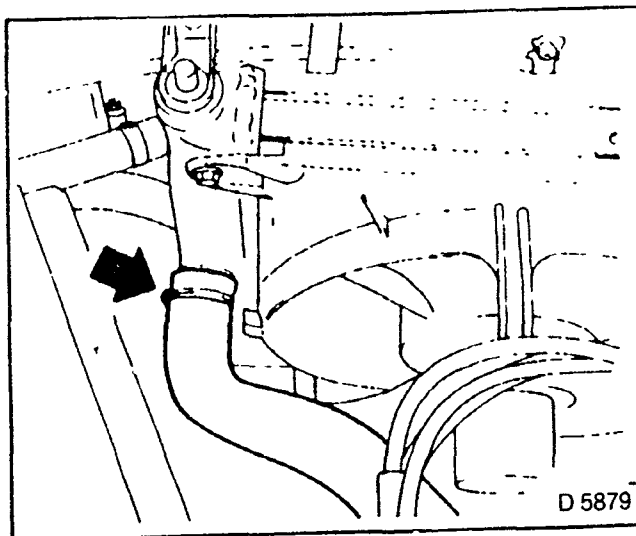


Fig. 167

**REMOVE, DISCONNECT**

1. Air cleaner
2. If present: Air intake hose.  
Pre-volume chamber.
3. All cable connections.
4. Hoses and lines from engine.
5. Accelerator cable.

**NOTE:**

1. Mark fuel lines before removal.
2. Close off with spring clips.

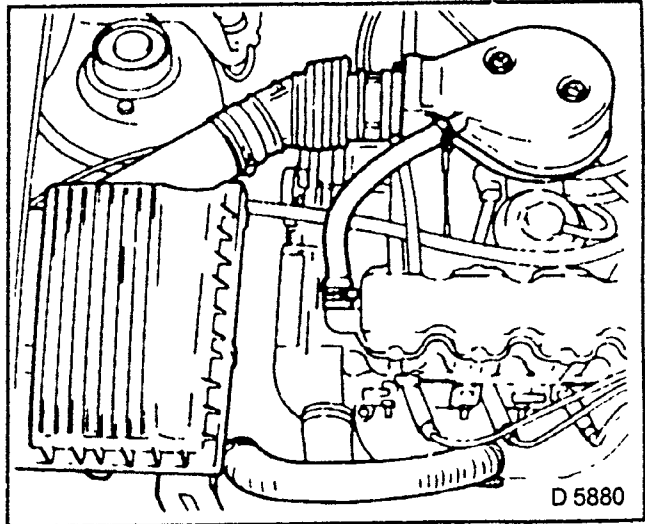


Fig. 168

**REMOVE, DISCONNECT**

1. Transmission from engine — upper bolts.

**NOTE:**

**LEAVE ONE FASTENING BOLT IN TO RETAIN.**

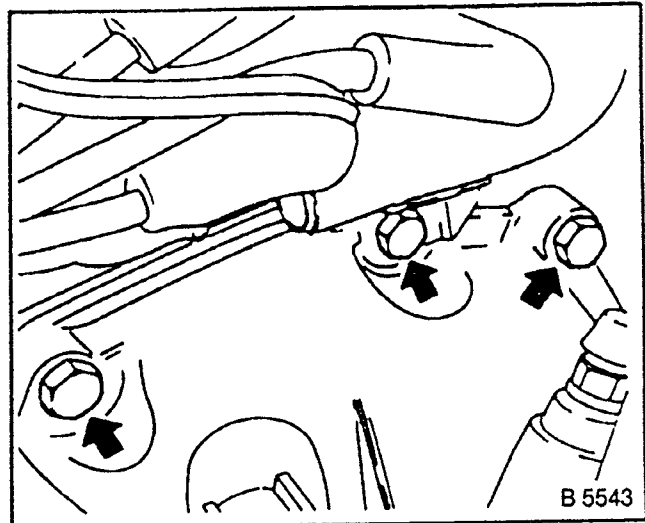


Fig. 169

Attach engine to Engine Holder KM-263-B.

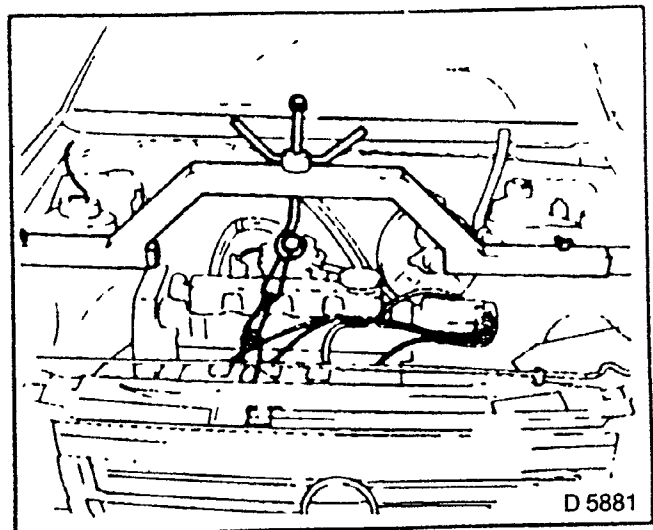


Fig. 170

**REMOVE, DISCONNECT**

1. Front exhaust pipe.

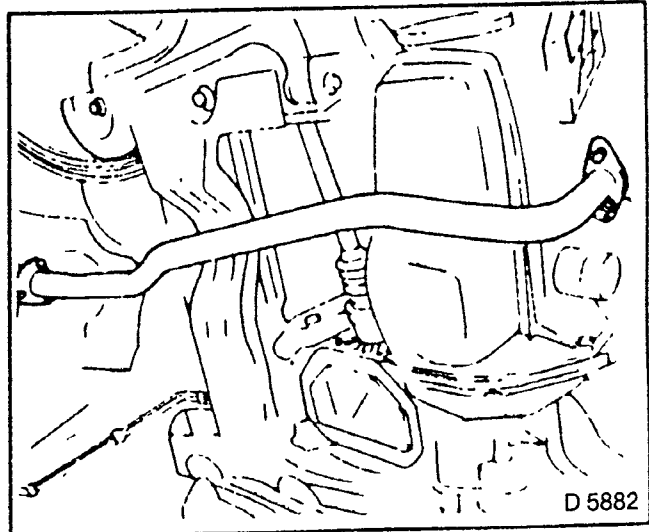


Fig. 171

**REMOVE, DISCONNECT**

1. Clutch assembly —  
See corresponding operation in Section K.
2. Engine right damping block from side member.
3. Engine suspension bracket from cylinder block.
4. Transmission from engine — lower bolts.

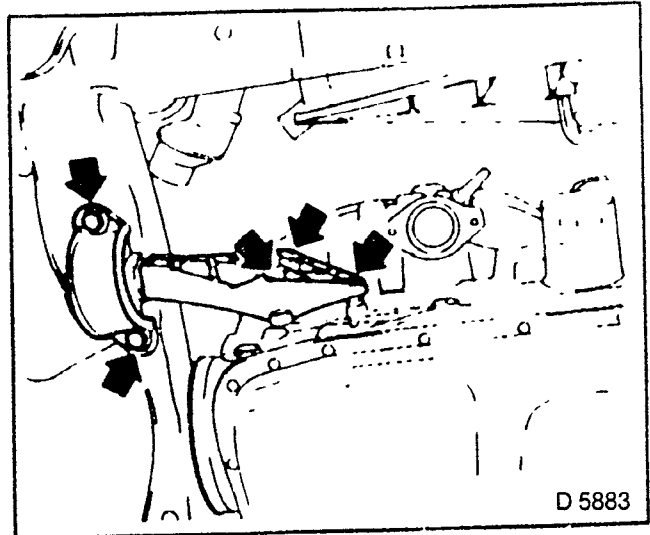


Fig. 172

5. Support engine with jack.
6. Remove KM-263-B.
7. Place engine on steel cable.
8. Unbolt upper fastening bolt for transmission — engine (retaining).
9. Support transmission with vehicle jack
10. Press engine off from transmission.
11. Lift out

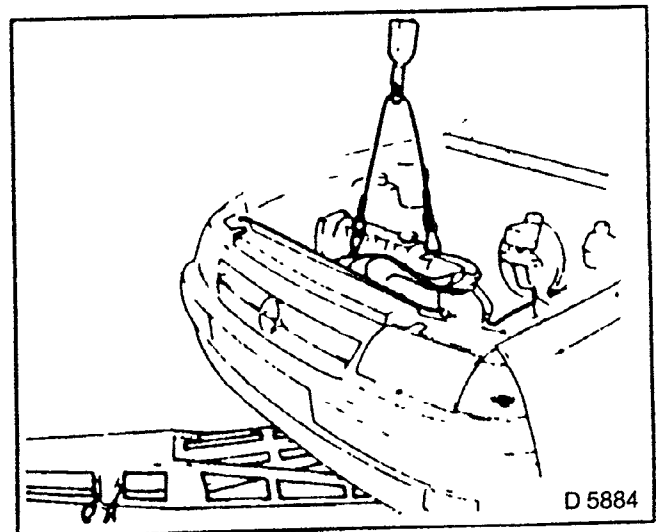
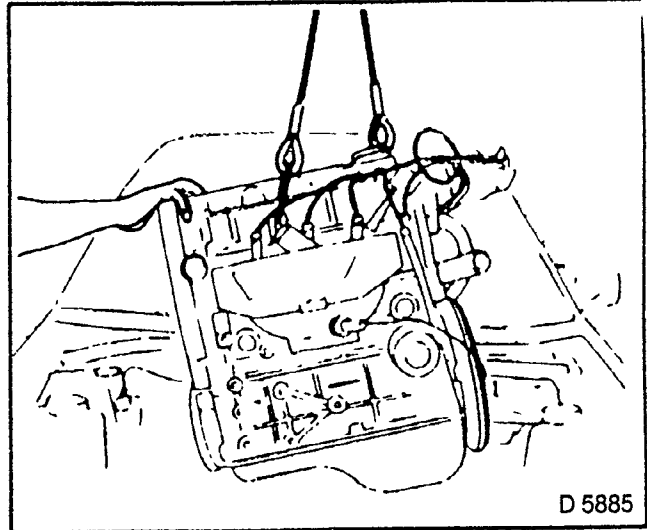


Fig. 173

**INSTALL, CONNECT**

1. Lower engine.
2. Insert guide sleeves of engine block into transmission.
3. Support engine with vehicle jack.
4. Remove steel cable.

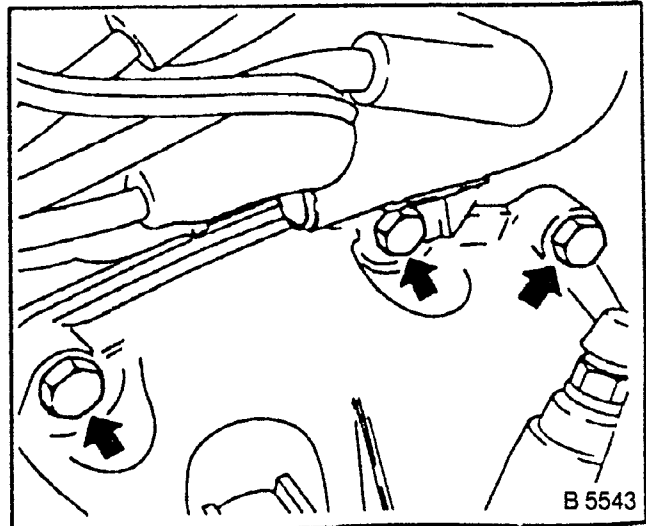


D 5885

Fig. 174

**TIGHTEN (TORQUE)**

1. Transmission to engine.
2. Upper bolts — 75 Nm



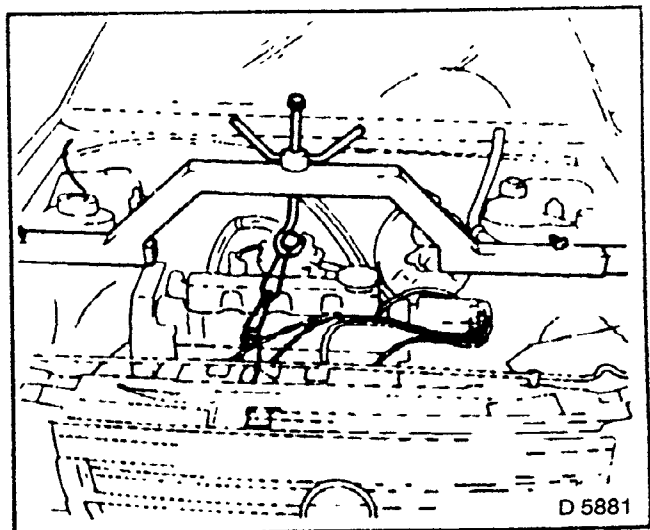
B 5543

Fig. 175

3. Attach engine to Engine Holder KM-263-B.
4. Remove vehicle jack.

**INSTALL, CONNECT**

1. Engine suspension bracket to cylinder block.
2. Engine damping block to side member.
3. Turn fastening bolts by hand.



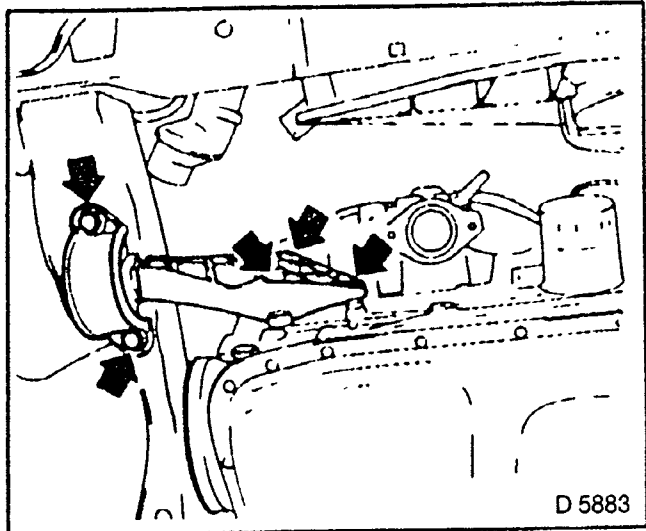
D 5881

Fig. 176

**TIGHTEN (TORQUE)**

1. Transmission to engine, lower bolts — 75 Nm.
2. Engine suspension bracket to cylinder block — 60 Nm
3. Engine right damping block to side member — 65 Nm\*.

\*Insert bolts with Locking Compound (Locktite 242).

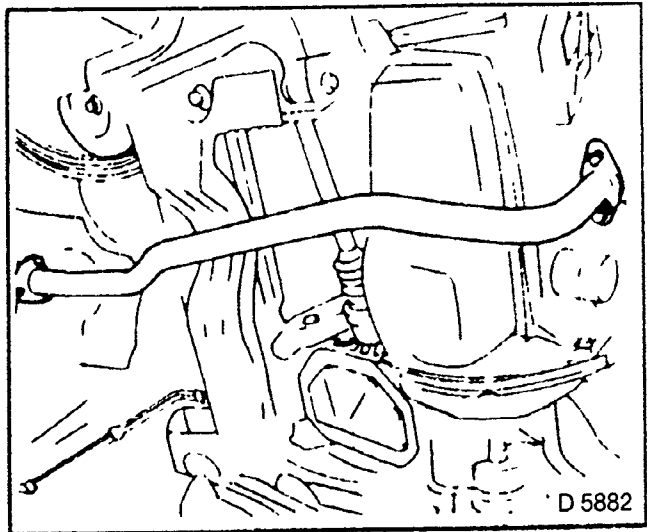


D 5883

Fig. 177

**INSTALL, CONNECT**

1. Clutch assembly.  
See corresponding operation in Section K.
2. Front exhaust pipe.
3. Remove KM-263-B.

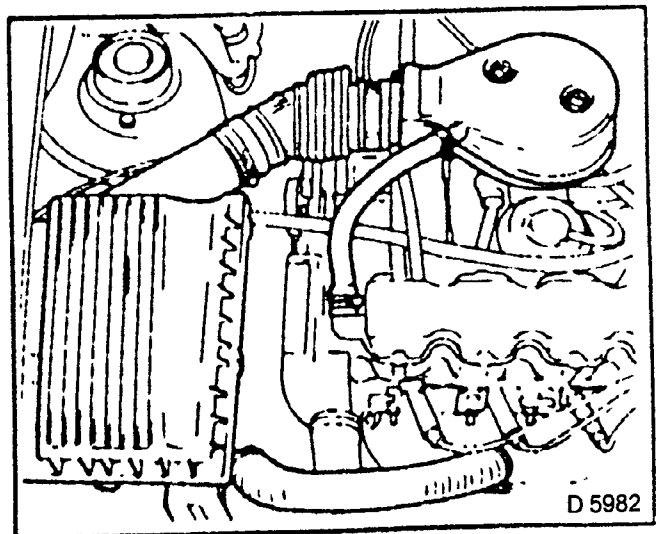


D 5882

Fig. 178

**INSTALL, CONNECT**

1. All hose, line and wiring connections to engine.
2. Note condition and seating.
3. Note marks made when installing fuel lines.
4. Remove spring clips.
5. Install accelerator cable free of tension.
6. Air cleaner.
7. If present: Air intake hose.  
Pre-volume chamber.



D 5982

Fig. 179

**INSTALL, CONNECT**

1. Battery.
2. Bonnet

**INSPECT**

1. Engine oil level.
2. Bleed hydraulic system — see corresponding operation in Section M.
3. Fill up and bleed cooling system.
4. Check for leaks.

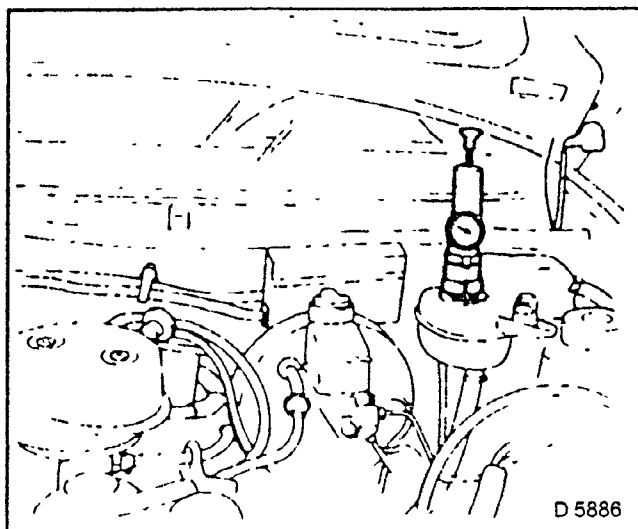


Fig. 180

**Engine — Repair Using Short Block**

1. Remove attaching parts.
2. Install engine on Engine Overhaul Stand KM-412 with appropriate adaptors.
3. Drain engine oil — place collecting pan underneath.

**REMOVE, DISCONNECT**

1. Toothed belt rear cover.

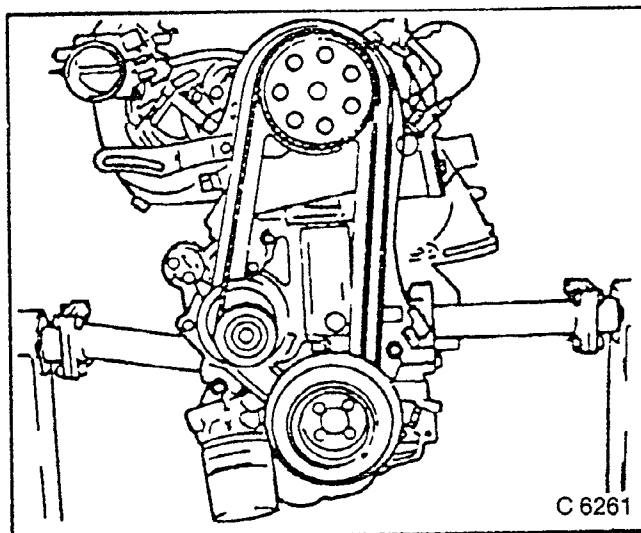


Fig. 181

**REMOVE, DISCONNECT**

1. Water pump.
2. Starter.
3. Line and flange for crankcase ventilation.
4. Inductive pulse pick-up, if present.

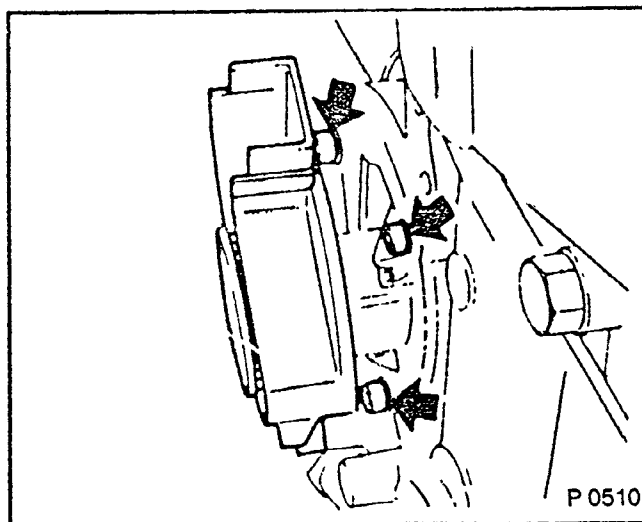
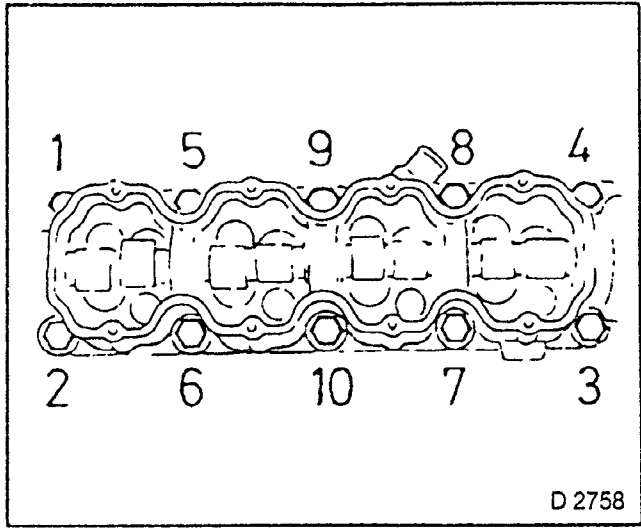


Fig. 182



**REMOVE, DISCONNECT**

- 1. Cylinder head.
- 2. Loosen bolts in a spiral pattern from outside inwards — at first 1/4, then 1/2 turn.
- 3. Camshaft housing from cylinder head.
- 4. Remove rocker arms.
- 5. Thrust plates.
- 6. Hydraulic valve lash adjusters.



D 2758

Fig. 183

**REMOVE, DISCONNECT**

- 1. Oil pan.
- 2. Oil intake tube.
- 3. Baffle plate — if present.

**CLEAN**

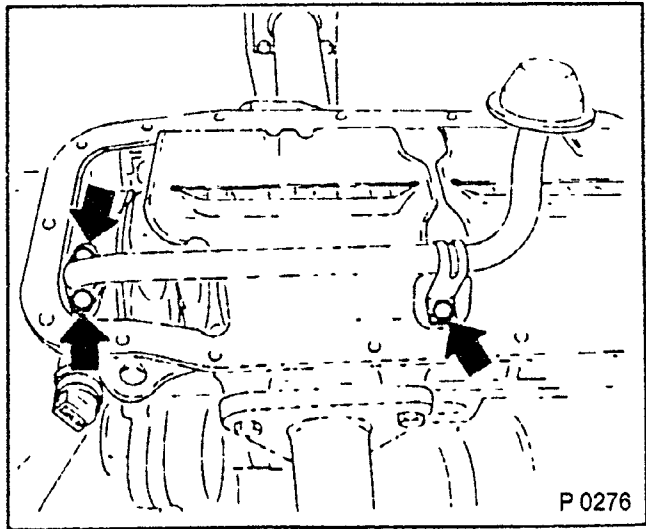
**INSPECT**

Replace all parts if necessary.

**New Short Block — Complete**

**TIGHTEN (TORQUE)**

- 1. Intake manifold to oil pump — 8 Nm.
- 2. Insert bolts with Locking Compound (Loctite 242).
- 3. Cover joints (cylinder block oil pump housing and cylinder block bearing cover) with Sealing Compound.
  - On 1,4 and 1,6 ltr. engine, mount cork gasket.
  - On 1,6 ltr. engine, mount baffle plate and second cork gasket.
  - On 1,8 and 2,0 ltr. engine, fit gasket on baffle plate.

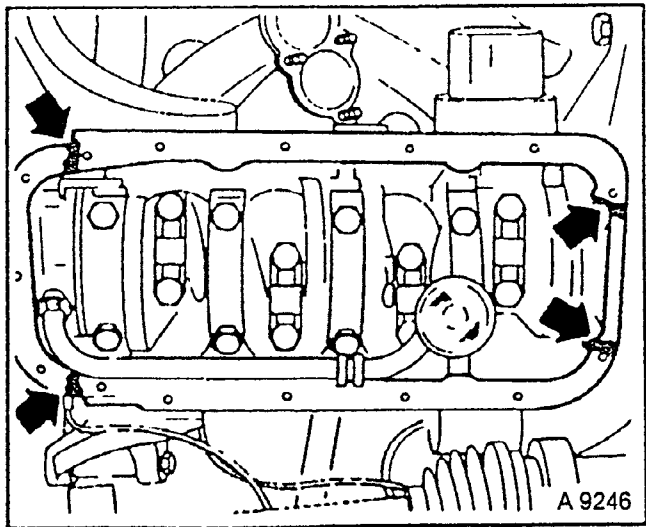


P 0276

Fig. 184

**TIGHTEN (TORQUE)**

Engine	1,4/1,6 ltr.	1,8/2,0 ltr.
Bracket for intake manifold to cylinder block	8 Nm	6 Nm
Oil pan to cylinder block*	8 Nm	5 Nm
Oil drain plug to oil pan	55 Nm	45 Nm



A 9246

Fig. 185

\*Insert bolts with Locking Compound (Loctite 242).

**INSTALL, CONNECT**

1. Centering sleeves into cylinder block to stop using KM-427.

**INSPECT**

1. Cylinder head for plane surface.
2. Put on cylinder head gasket — identification mark "OBEN/TOP" facing upwards and to timing side of engine.

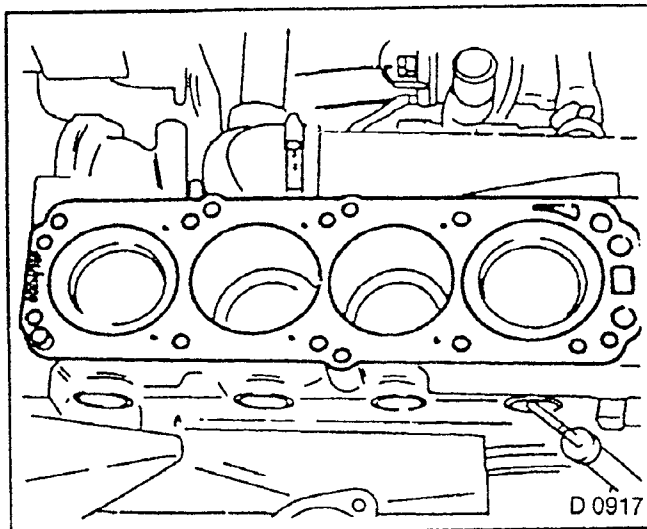


Fig. 186

**INSTALL, CONNECT**

1. Cylinder head — 1st cylinder in TDC position.
2. Coat sliding surfaces of hydraulic valve lash adjusters, thrust plates and rocker arms with MoS<sub>2</sub> paste.
3. Camshaft housing — Sealing Compound (Loctite 242).

**NOTE:**

1. Use new cylinder head bolts.
2. Screw in bolts to stop.

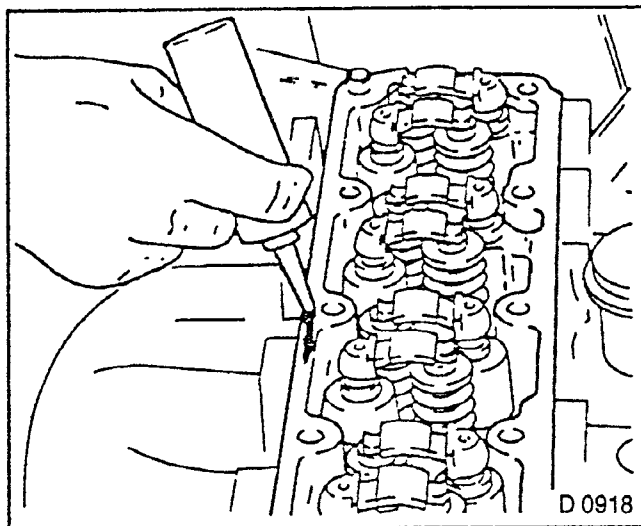


Fig. 187

**TORQUE — ANGLE METHOD**

1. Cylinder head to cylinder block.
2. Tighten bolts in spiral pattern from inside outwards — in four stages, torque wrench and Angle Torque Wrench KM-470-B.  
 1,4/1,6 ltr., engine:  
 55 Nm + 60° + 60° + 30°.  
 1,8/2,0 ltr. engine:  
 25 Nm + 60° + 60° + 60°

**NOTE:**

**AFTER TEST RUN, TIGHTEN CYLINDER HEAD BOLTS ANOTHER 30° + 15°.**

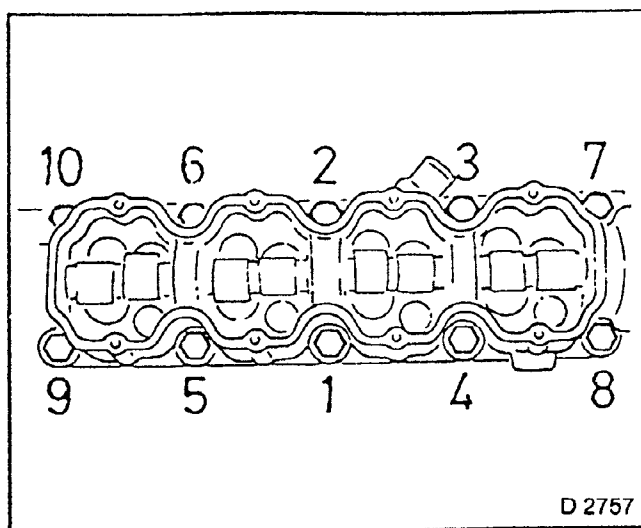


Fig. 188

**TIGHTEN (TORQUE)**

Engine	1,4/1,6 ltr.	1,8/2,0 ltr.
Starter to cylinder block	25 Nm	*45 Nm
Starter support to cylinder block	—	25 Nm

\*Engine side — on transmission side, tighten to 75 Nm after installing engine.

1. Install line and flange for crankcase ventilation, inductive pulse pick-up.
2. Check distance between inductive pulse pick-up and increment disc.

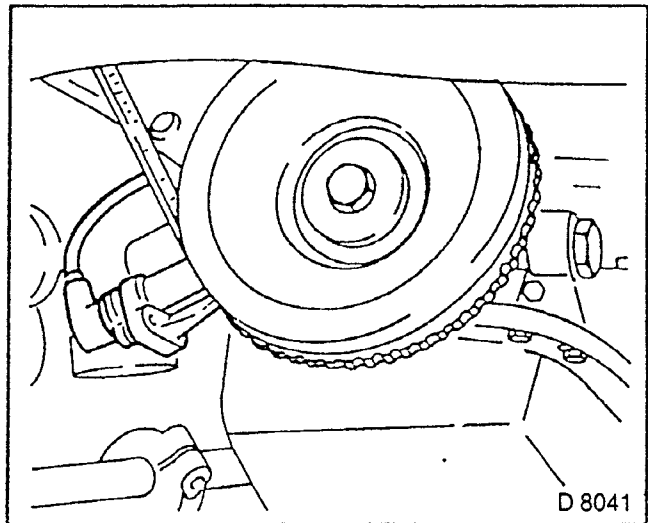


Fig. 189

**INSTALL, CONNECT**

1. Water pump — new rubber O-ring.
2. Coat sealing surfaces with Silicone Grease B0400571 (Kluber Unisilikon TK 572/300).
3. Toothed belt rear cover.
4. Top up engine oil to "MAX" marking on oil dipstick.

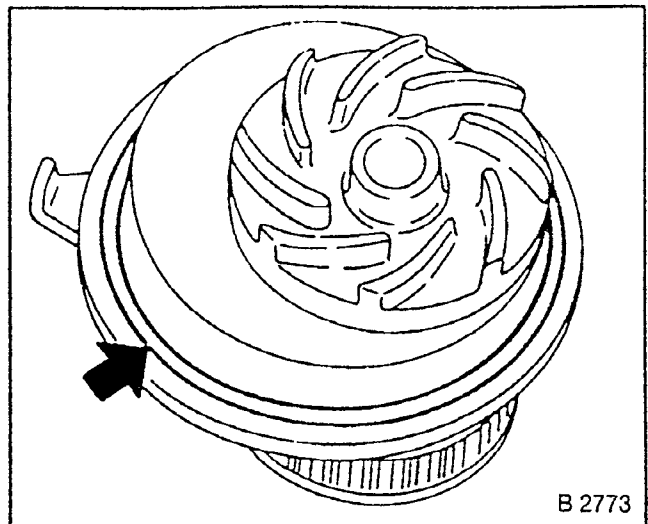


Fig. 190

**NOTE:**

**BEFORE INSTALLATION OF TOOTHED BELT, CHECK TIMING.**

**REMOVE, DISCONNECT**

1. Engine from Engine Stand KM-412.
2. Adapter from engine.
3. Install engine.

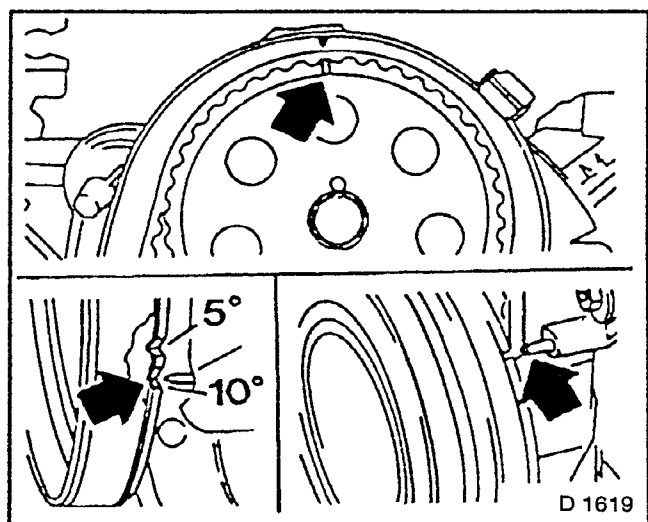


Fig. 191

## 2 E 3 CARBURETTOR (14NV)

### Idle Speed and CO Content in Exhaust — Adjust

Checking conditions:

1. Engine functioning correctly — valves, timing.
2. Oil temperature  $\geq 80^{\circ}\text{C}/173^{\circ}\text{F}$ .
3. Ignition system functioning correctly.
4. Intake system leakproof.
5. Clean air filter installed.
6. Intake air pre-heating correct.
7. Acceleration actuation correct.
8. Electrical consumers switched off.

Checking conditions:

1. Tachometer and CO tester connected.
2. Adjusting screw (3) must not touch stepped plate (4).

AT: selector lever position "P"

#### ADJUST

1. Idle speed at adjusting screw (1).
  2. CO content in exhaust at mixture adjusting screw (2) — see fig. 192.
- Adjustment values: see Technical Data, page 312.
- If adjustment not possible, see "Trouble-shooting Chart", page 98.

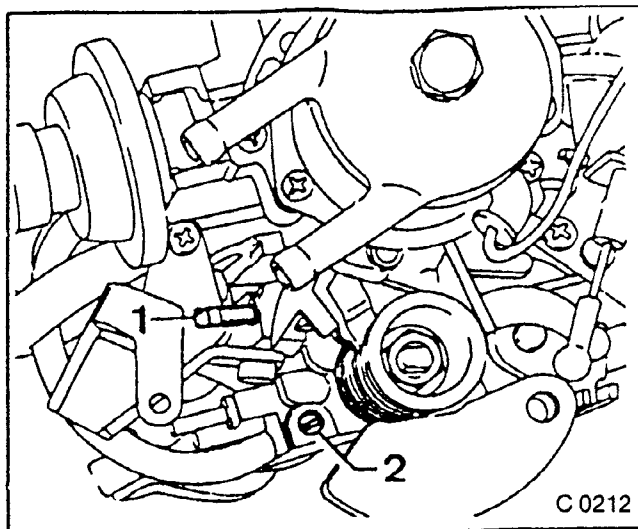


Fig. 192

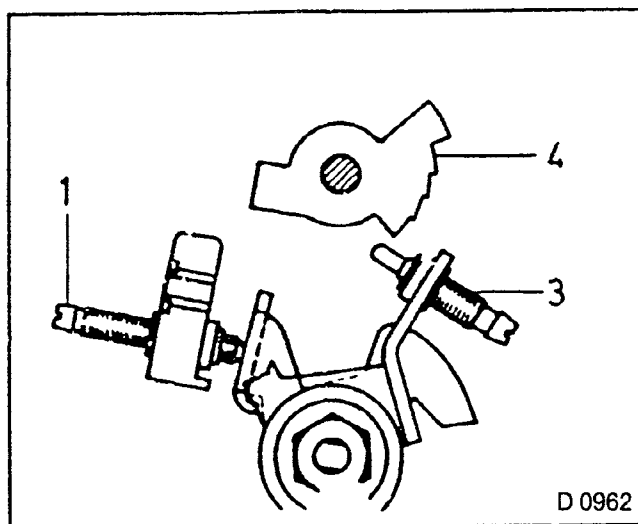


Fig. 193

### Fast Idle — Check and Adjust

CHECKING CONDITIONS:

1. Oil temperature  $\geq 80^{\circ}\text{C}/176^{\circ}\text{F}$ .
2. Idle speed adjustment correct.

#### ADJUST

1. Adjusting screw (3) on 2nd highest stage of stepped plate (4).
2. Start engine without touching accelerator pedal.
3. Adjustment on adjusting screw (3).
4. Replace safety catch.
5. Adjustment values: see Technical Data, page 312.

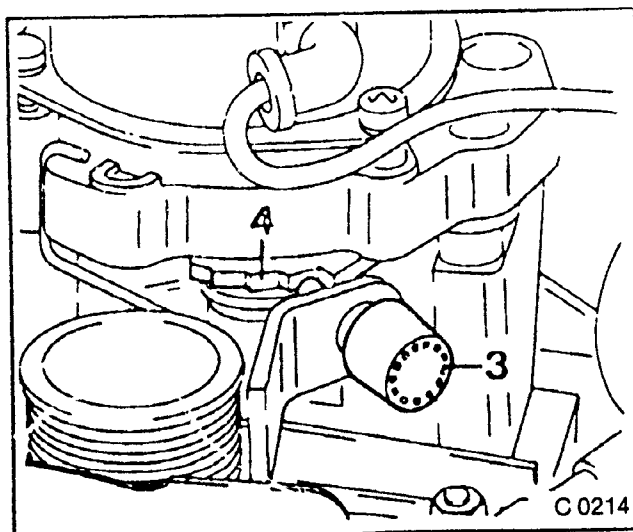


Fig. 194

## Pulldown Unit — Check

### CHECK PULLDOWN UNIT:

### REMOVE, DISCONNECT

- 1 Air cleaner.
- 2 Vacuum hoses (1) and (2) from carburettor.
- 3 Close off connection (1).
- 4 Connect Vacuum Hand Pump MKM-667 to (2).
- 5 Create pressure difference of 300 mbar/43.5 psi.

### INSPECT

1. Pulldown unit (3) for leaks.
2. Pressure difference must remain constant.
3. If not, to eliminate leaks, if necessary, replace pulldown unit.

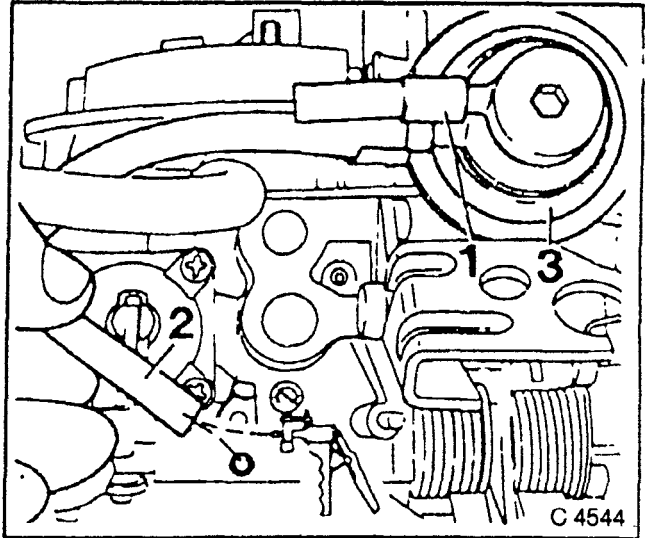


Fig. 195

## THERMO TIME VALVE, CHECK

### CHECKING CONDITIONS:

1. Thermo time valve (1) at temperature of approximately 20°C/68°F.
2. Current supply to wiring harness plug (2) correct — at least 11,5 volts.

### INSPECT

1. Function of thermo time valve.
2. Measure electrical resistance — 4,5 to 7,5 ohms at 20 to 30°C/68 to 86°F
3. Connect Vacuum Pump MKM-667 and actuate — thermo time valve must have passage.
- 4 Attach wiring plug (2) to thermo time valve (1).
5. Ignition switched on.
6. Actuate Vacuum Hand Pump MKM-667 continuously.
7. Ascertain switchover time — 4 to 10 seconds at + 20°C/68°F until increase in pressure difference.
8. If necessary, replace thermo time valve.

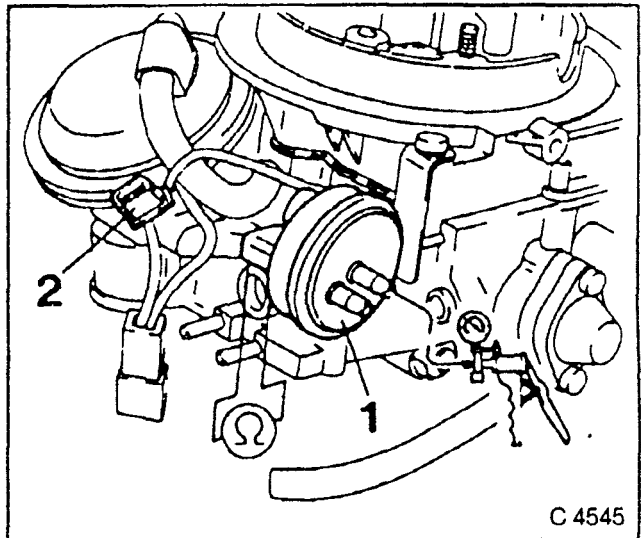


Fig. 196

# Thermo Time Valve — Remove and Install

## REMOVE, DISCONNECT

1. Fuel hose — if present
2. Air filter hood.
3. Wiring harness plug.
4. Vacuum line from thermo time valve (1).
5. Thermo time valve with bracket (2).

## INSTALL, CONNECT

1. Thermo time valve.
2. Vacuum line.
3. Wiring harness plug.
4. Air cleaner hood.
5. Fuel hose.

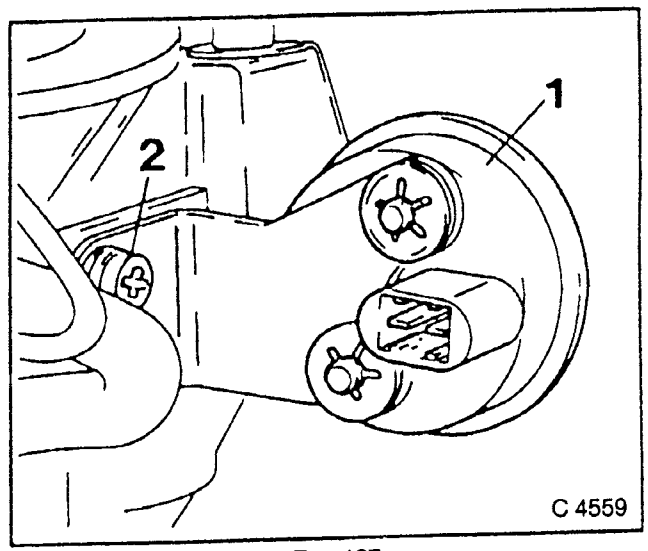


Fig. 197

C 4559

# Choke Valve Gap — Check and Adjust

## CHECKING CONDITIONS:

1. Pulldown unit free of leaks.
2. Choke cover removed.
3. Choke valve closed.
4. Adjusting screw (1) stays on highest stage of stepped plate (2).
5. Vacuum lines removed from pulldown box.

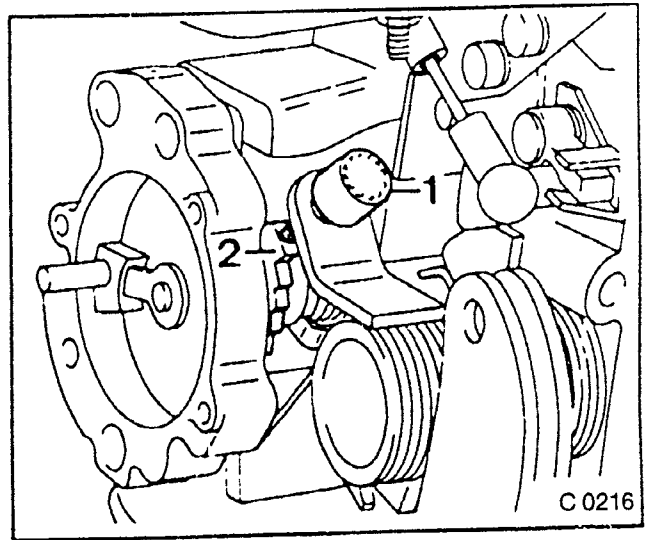


Fig. 198

C 0216

## “SMALL” CHOKE VALVE GAP, CHECK

### MEASURE

1. Choke valve gap — see Technical Data, page 312.
2. Push in pulldown diaphragm rod (1) with screwdriver to first pressure point.
3. Adjust pulldown gap (arrow) on the wide side if necessary by turning the adjusting screw on the pulldown unit (2).

Checking value: see Technical Data, page 312.

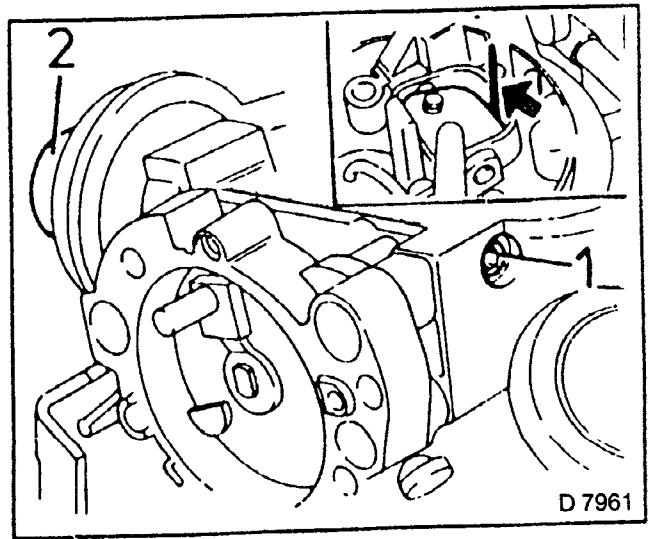


Fig. 199

D 7961

**“LARGE” CHOKE VALVE GAP, CHECK**

**MEASURE**

1. Choke valve gap — see Technical Data, page 312.
2. Same measurement as “small” choke valve gap however pulldown diaphragm rod pushed in as far as stop.
3. If necessary, adjust at adjusting screw (1) of diaphragm rod.

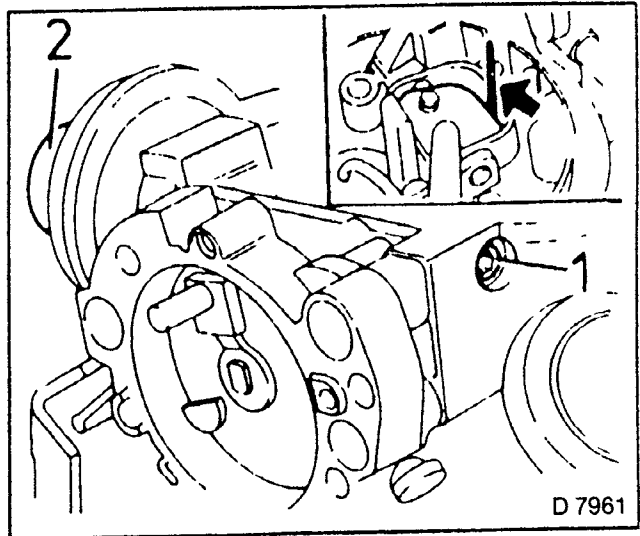


Fig. 200

**Choke Valve Forced Opening — Adjust**

**CHECKING CONDITIONS: CHOKE COVER REMOVED**

**MEASURE**

1. Choke valve gap.
  2. Press carrier lever (1) to stop in direction of arrow and detain with rubber ring.
  3. Throttle lever in full throttle position.
  4. If necessary, correct choke valve gap by bending the segment (2).
- Adjustment values — see Technical Data, page 312.
- Opening too small — Enlarge gap of segment (2) — screwdriver.
- Opening too small — Lessen gap of segment (2) — pointed pliers.

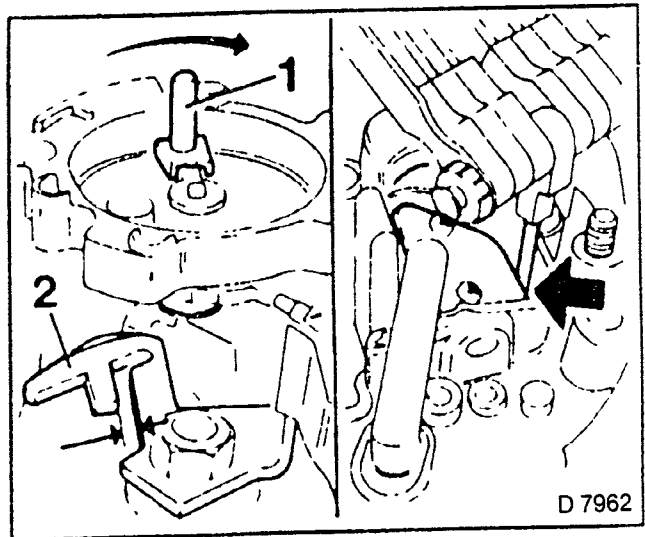


Fig. 201

**Position of Stepped Plate — Check and Adjust**

**CHECKING CONDITIONS:**

1. Choke valve gap correct.
2. Choke cover removed.

**INSPECT**

1. Position of stepped plate.
2. Open throttle valve.
3. Press driving lever (3) lightly in direction of arrow.
4. Close throttle valve again.
5. Adjusting screw (4) must rest on stop of second highest stage of stepped plate (1).
6. Check choke valve gap — see Technical Data, page 312.

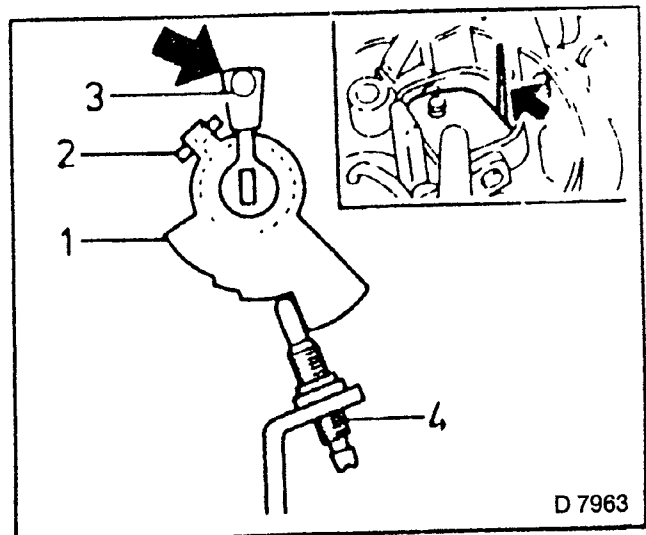


Fig. 202

**ADJUST**

- 1. Position of stepped plate (1).
- 2. Correct by bending the lever (2).

**NOTE:**

**CORRECT POSITION OF RETURN SPRINGS (ARROW).**

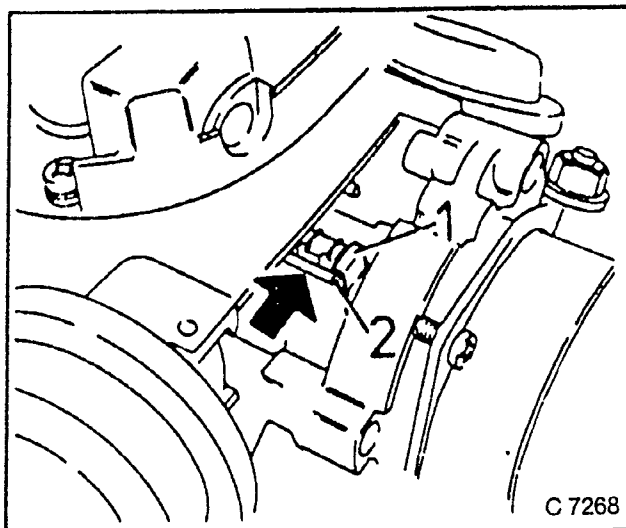


Fig. 203

**Choke Cover Position — Check**

**INSPECT**

Notch marks must align.

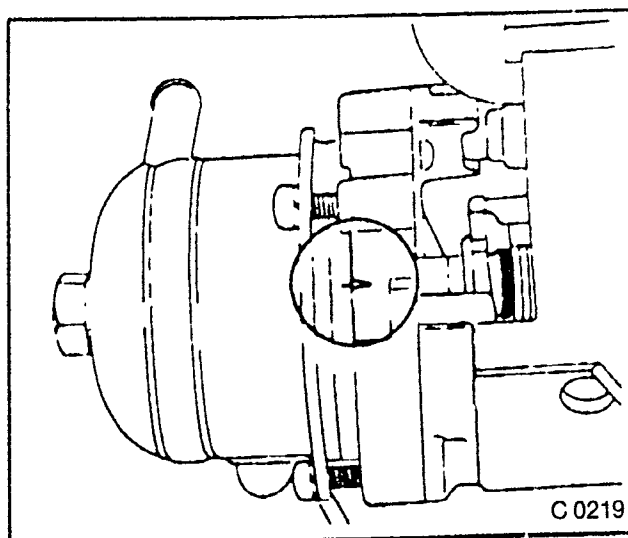


Fig. 204

**Cold Start Adjustment, Throttle Valve Gap — Check and Adjust**

**CHECKING CONDITIONS:**

- 1. Carburettor removed, adjusting screw (1) rests on highest stage of stepped plate (2).

**MEASURE**

- 1. Throttle valve gap — if necessary correct with drill.
- 2. Correction at adjusting screw (1).
- 3. Correct fast idling speed after installing carburettor.  
Adjustment value — see Technical Data, page 312.
- 4. Replace safety catch at adjusting screw (1).

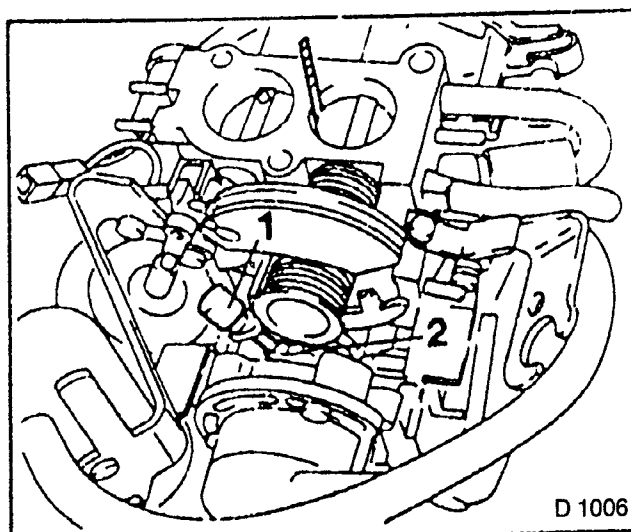


Fig. 205



## Basic Adjustment of Throttle Valve — Stage II, Check

### MEASURE

1. Throttle valve gap — feeler gauge 0,05 mm.
2. Throttle valve gap stage II is adjusted at the factory and should only be corrected if all other causes of fault are eliminated and malfunctions exist on the throttle valve stage II (throttle valve jams, idle speed adjusting problems) — see Trouble-shooting Chart, page 98.
3. Correction at the throttle valve stop screw (1).

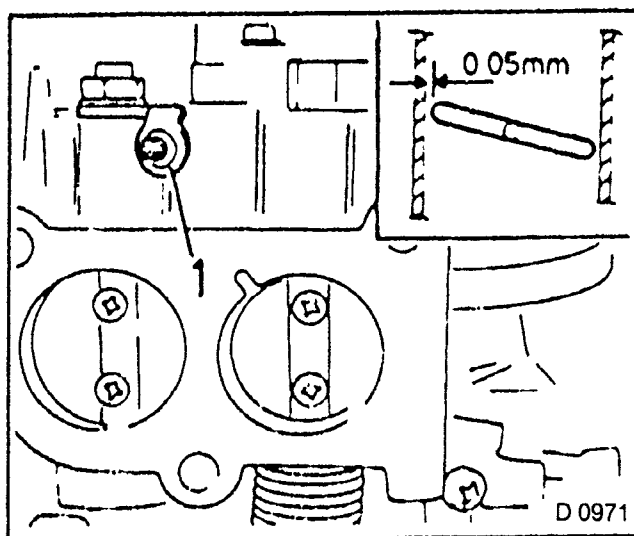


Fig. 206

## Injection Quantity — Check and Adjust

### CHECKING CONDITIONS:

1. Float chamber normal level, fuel must flow.
2. Start of injection immediately after throttle valve actuation.
3. Carburettor removed.

### MEASURE

1. Injection quantity — carburettor checking instrument.
2. Turn stepped plate (4) and hold, so that adjusting screw (3) does not rest on it.
3. Open throttle valve fully ten times — 1 second/stroke, pause three seconds between strokes.  
Checking value — see Technical Data, page 312.

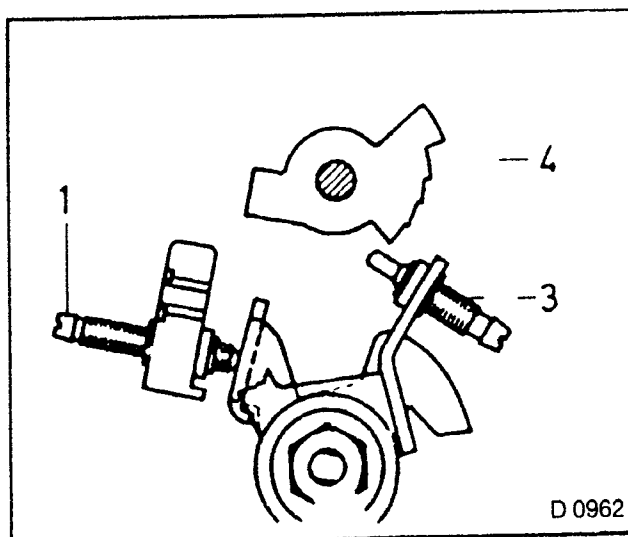


Fig. 207

### ADJUST

1. Injection quantity.  
If deviations from checking value exist, check accelerator pump.  
If necessary replace defective parts.
2. Loosen clamp bolt (1) and turn curved plate (2).  
Injection quantity larger: in direction of "+"  
Injection quantity smaller: in direction of "-"

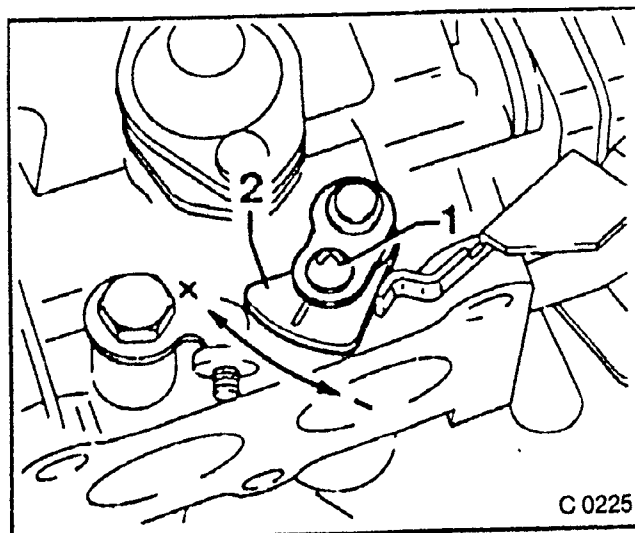


Fig. 208

## Accelerator Pump — Remove and Install

### REMOVE, DISCONNECT

1. Air cleaner hood.
2. Pump cover with pump lever (1).
3. Pump diaphragm (2).
4. Pump spring (3).
5. Spring washer.
6. Pump intake valve (4).

### INSTALL, CONNECT

1. Accelerator pump assembly — sequence portrayed.
2. Observe correct seating and sealing.
3. Clean return nozzle (5).
4. Air cleaner hood.

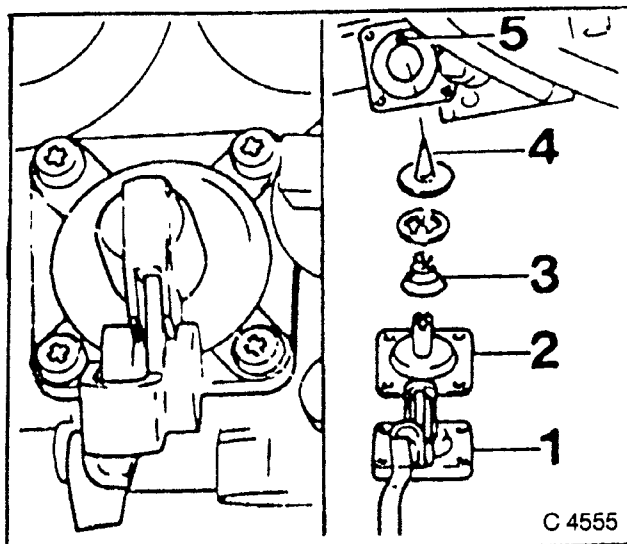


Fig. 209

## Release and Forced Return — Stage II, Check and Adjust

### CHECKING CONDITIONS:

1. Carburettor removed.
2. Throttle valve stage I in idle speed position.

### MEASURE

1. Distances "1" and "2" — each on the narrowest position.  
Adjusting values — see Technical Data, page 312.  
If necessary, correct by bending forks.

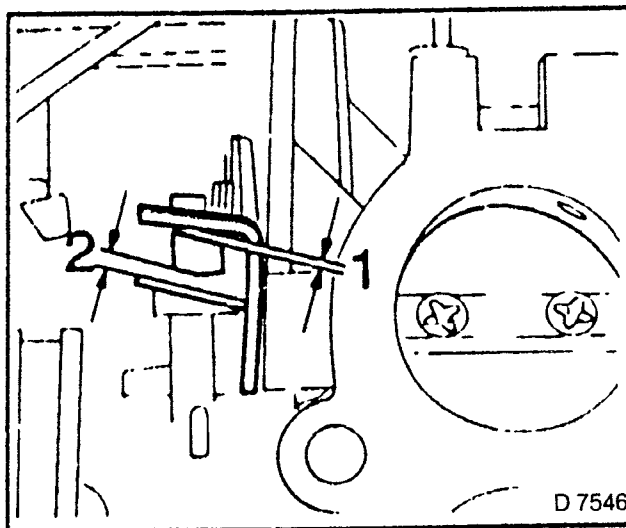


Fig. 210

## Pull Rod for Stage II — Check

### CHECKING CONDITIONS:

Release and forced return correct.

### MEASURE

1. Pre-tension — see Technical Data, page 312.
2. Hang out ball socket (1). If necessary replace vacuum unit stage II.

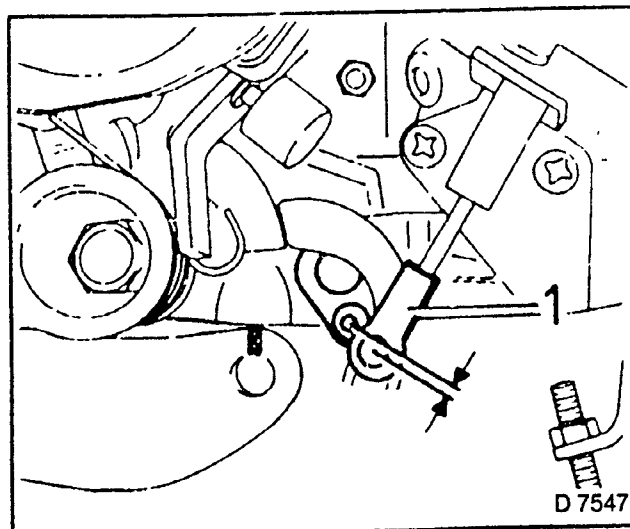


Fig. 211

## Vacuum Unit — Stage II — Check for Leaks

### INSPECT

1. Vacuum line and vacuum unit stage II for leaks.
2. Connect Vacuum Hand Pump MKM-667 and create pressure difference. If reduction in pressure difference is found, the vacuum unit/vacuum line is defective. Replace if necessary.

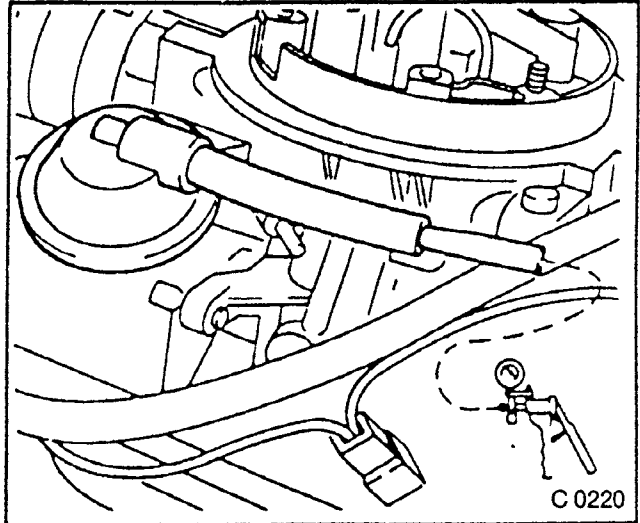


Fig. 212

## Vacuum Unit — Stage II — Remove and Install

### CARBURETTOR REMOVED

### REMOVE, DISCONNECT

1. Choke cover.
2. Gas bubble separator — if present.
3. Vacuum unit line from carburettor, pull rod (1).
4. Vacuum unit (3) with bracket (2) (arrows)

### INSTALL, CONNECT

1. Vacuum unit to carburettor.
2. Check pre-tension of pull rod — see Technical Data, page 312.
3. Vacuum line.
4. Gas bubble separator.
5. Choke cover.

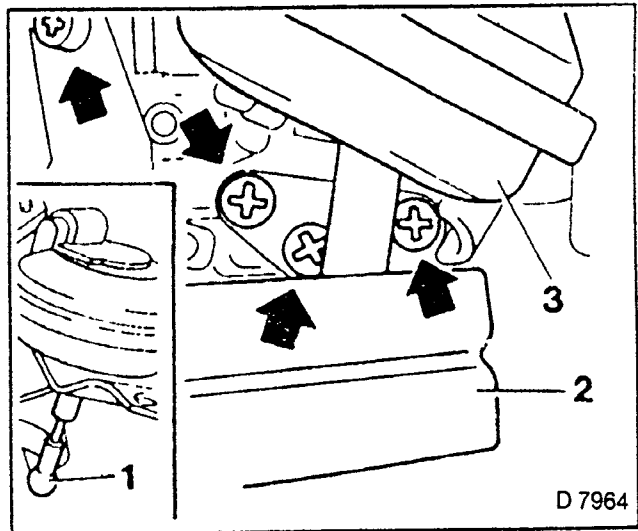


Fig. 213

## Enrichment Valve, Remove and Install

### REMOVE, DISCONNECT

1. Air cleaner hood.
2. Diaphragm cover (1).
3. Pressure spring (2).
4. Enrichment valve (3).

### INSTALL, CONNECT

1. Enrichment valve assembly.
2. Air cleaner.

Ensure there are no leaks, note correct seating and bore — hole in cover (1).

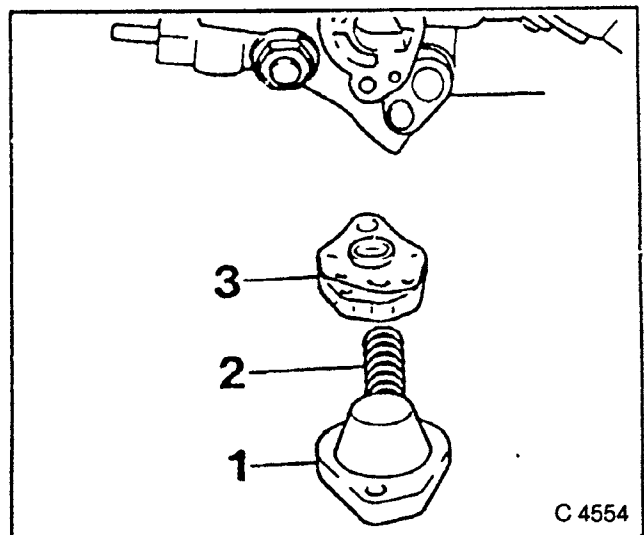


Fig. 214

## Choke Body — Remove and Install

CARBURETTOR REMOVED

NOTE:

OBSERVE INSTALLATION POSITION OF CONNECTING ROD (1) — Fig. 216.

REMOVE, DISCONNECT

1. Choke cover.
2. Choke body.

INSTALL, CONNECT

1. Choke body.
2. Adjust choke cover.

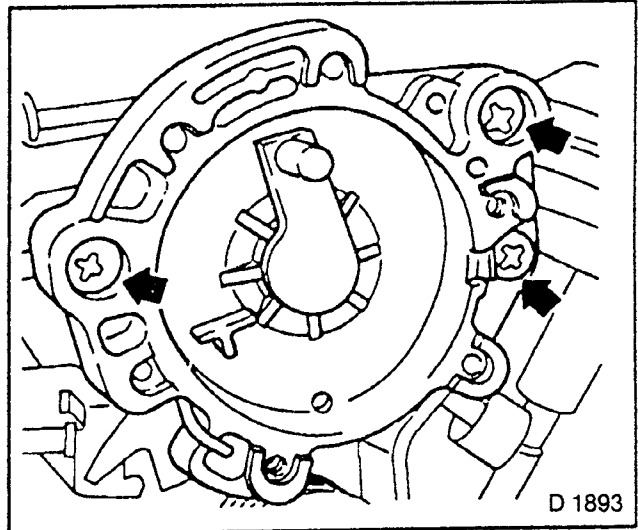


Fig 215

## Pulldown Unit — Remove and Install

REMOVE, DISCONNECT

1. Choke body.
2. Hose connections.
3. Pin.
4. Pulldown unit.

INSTALL, CONNECT

1. Pulldown unit.
2. Pin.
3. Hoses.
4. Choke body.

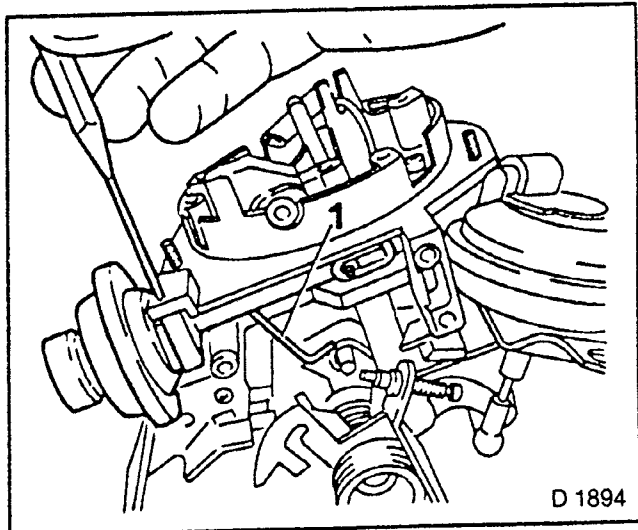


Fig. 216

INSPECT

1. Choke valve gap.

## 2 E 3 Carburettor — Remove and Install

REMOVE, DISCONNECT

1. Air cleaner hood.
2. Cable and line connections to carburettor.
3. Carburettor actuation.
4. Fastening bolts.

CLEAN

1. Sealing surfaces on carburettor and intake manifold flange.
2. Installation is carried out in reverse order — use new gasket.
3. Adjust carburettor actuation.

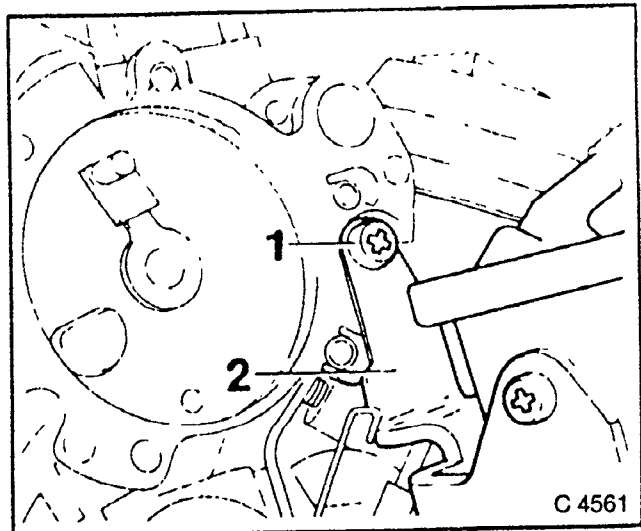


Fig. 217

## Carburettor Cover — Remove and Install (Carburettor Removed)

### REMOVE, DISCONNECT

1. Choke cover.  
If present, fastening screw (1) of gas bubble separator (2) — Fig. 217.
2. Vacuum lines from pulldown unit, carburettor cover — bolts (3, 4, 5, 6)  
Observe different lengths of bolts.  
Bolts (3, 4): 1 = 35 mm  
Bolts (5, 6): 1 = 25 mm

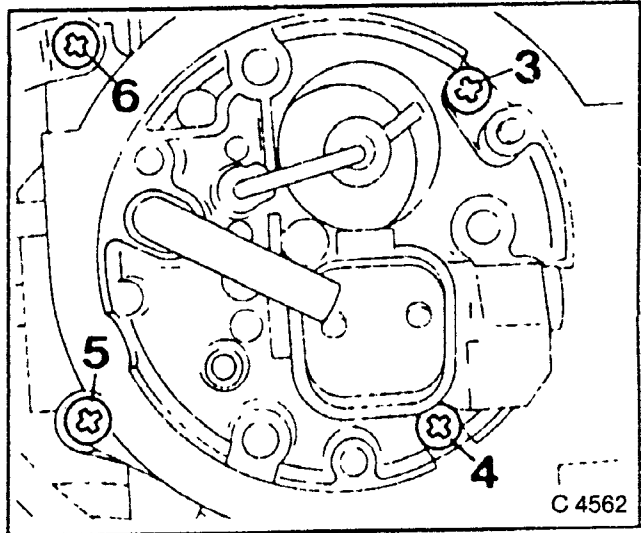


Fig. 218

### INSTALL, CONNECT

1. Carburettor cover — new gasket — fastening bolts — vacuum lines to pulldown unit.
- INSTALLATION NOTE:**  
Correct seating of the springs on flange of choke housing.

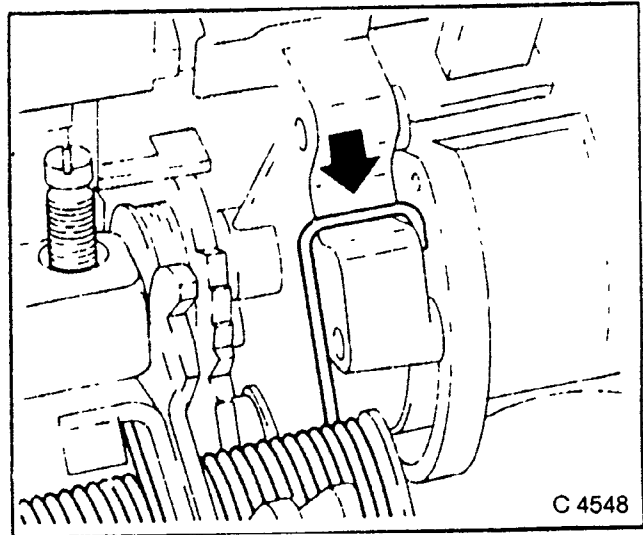


Fig. 219

## Float — Remove and Install

### REMOVE, DISCONNECT

1. Carburettor cover.
2. Pin (1).
3. Float (2) installing drift.

### INSTALL, CONNECT

1. Float.
2. Pin — note correct seating of float needle (3)
3. Carburettor cover.

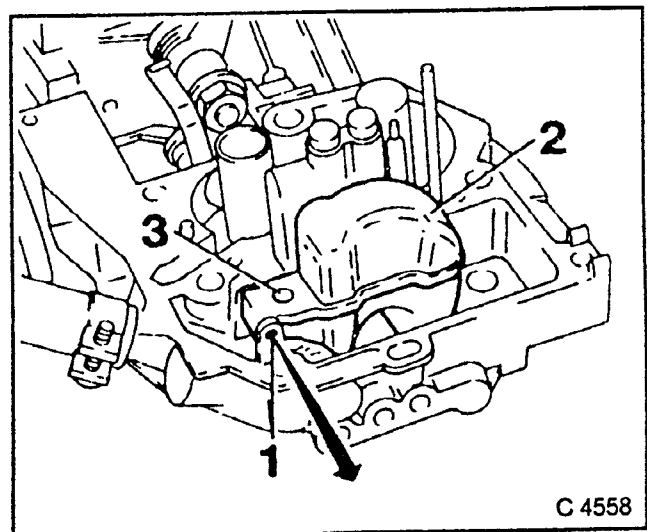


Fig. 220

## Main Nozzles — Remove and Install

### REMOVE, DISCONNECT

1. Carburettor cover.
2. Main nozzles: stage I (1), stage II (2).
3. Clean with compressed air.
4. Check nozzle size — see Technical Data.

### INSTALL, CONNECT

1. Main nozzles.
2. Carburettor cover.

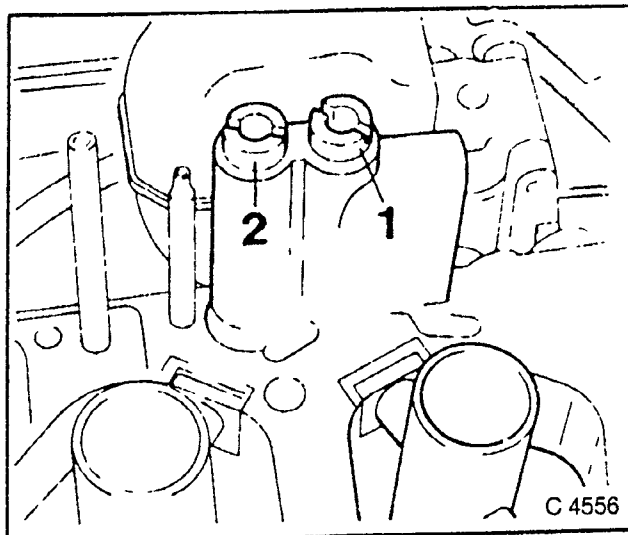


Fig. 221

## Idle Nozzle — Remove and Install

### REMOVE, DISCONNECT

1. Air cleaner hood.
2. Idle nozzle — near choke valve axle and air correction nozzle stage 1.
3. Clean with compressed air.
4. Check nozzle size — see Technical Data.

### INSTALL, CONNECT

1. Idle nozzle.
2. Air cleaner hood.
3. Check idling and CO content.  
If necessary, adjust.

## Pre-atomizer — Remove and Install

Carburettor cover removed.

### WARNING:

**DO NOT DAMAGE SEALING SURFACES.**

### REMOVE, DISCONNECT

1. Lever out pre-atomizer (alternately on either side).
2. Retaining clip (2).
3. Gasket (1).

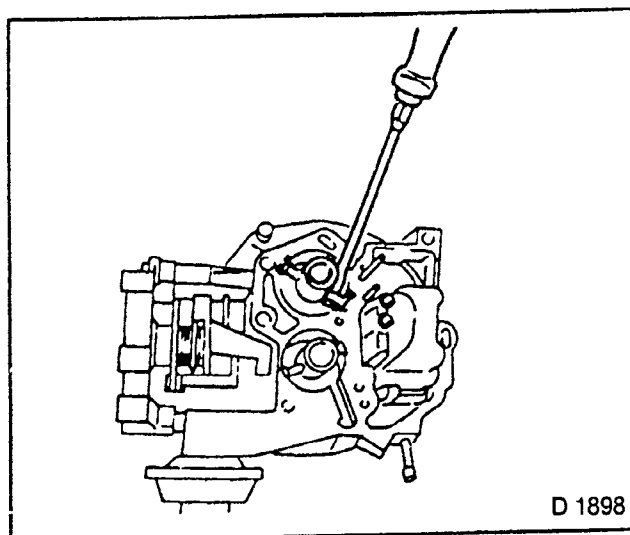


Fig. 222

**NOTE:**

**ENSURE PERFECT SEATING OF GASKET (1) AND RETAINING CLIP (2).**

**INSTALL, CONNECT**

1. Retaining clip.
2. Gasket.
3. Press in pre-atomizer.

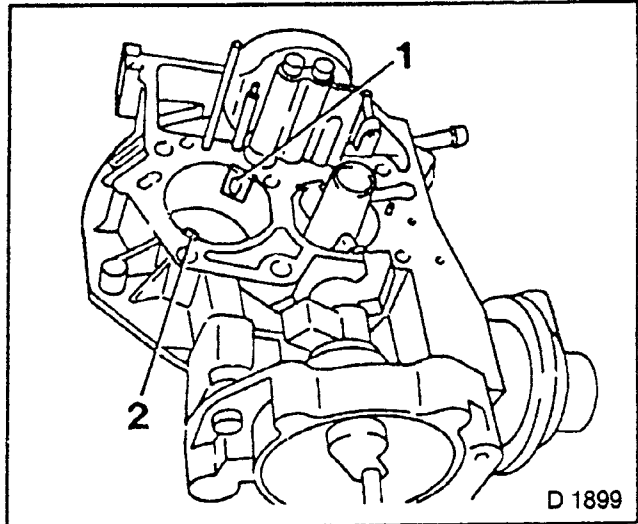


Fig. 223

**Accelerator Pipe —  
Remove and Install**

Carburettor cover removed.

**WARNING:**

**DO NOT DAMAGE SEALING SURFACE, NOTE O-RING (1) AND SCREEN (2).**

**REMOVE, DISCONNECT**

1. Accelerator pipe.

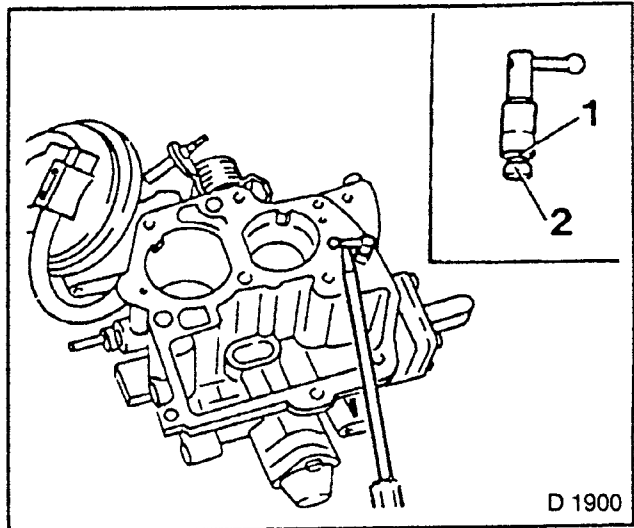


Fig. 224

**INSTALL, CONNECT**

1. Insert (press in) accelerator pipe so that the fuel jet sprays in the direction of the recess (arrow).

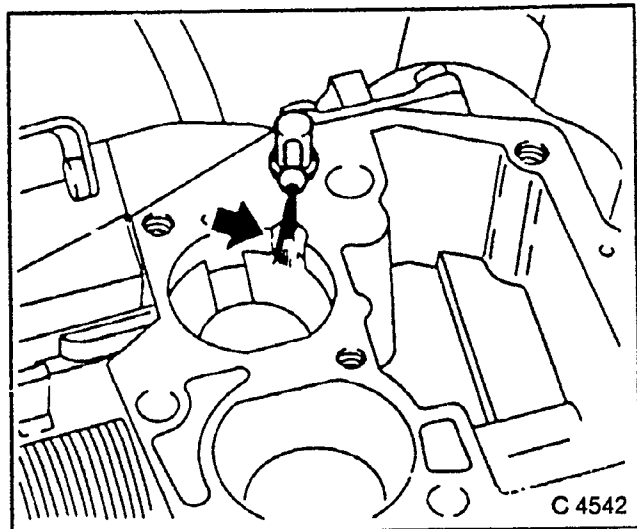


Fig. 225

## Float Level — Check

### REMOVE, DISCONNECT

1. Carburettor.
2. Carburettor cover.

### MEASURE

1. Float level. Dimension — see Technical Data.
2. Hold carburettor slanted when measuring so that the valve pin (1) is not caused to deflect by the float weight. The float level is dependent on the float weight — see Technical Data — and therefore not adjustable — if necessary replace float.

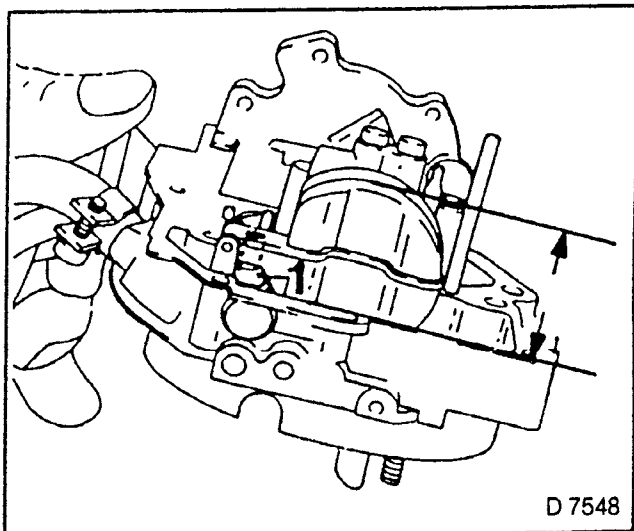


Fig. 226

## Carburettor Actuation — Adjust

### ADJUST

When adjusting idle speed, accelerator cable must be free of tension, slight play must be present in accelerator cable.

## Filter in Fuel Feed — Remove and Install

### REMOVE, DISCONNECT

1. Fuel feed line from carburettor.
2. Filter.
3. Turn M 3 bolt approximately 5 mm into filter and remove filter.

### INSTALL, CONNECT

1. Filter — push in until it engages.
2. Fuel feed line to carburettor.
3. Replace filter each time the carburettor is cleaned.

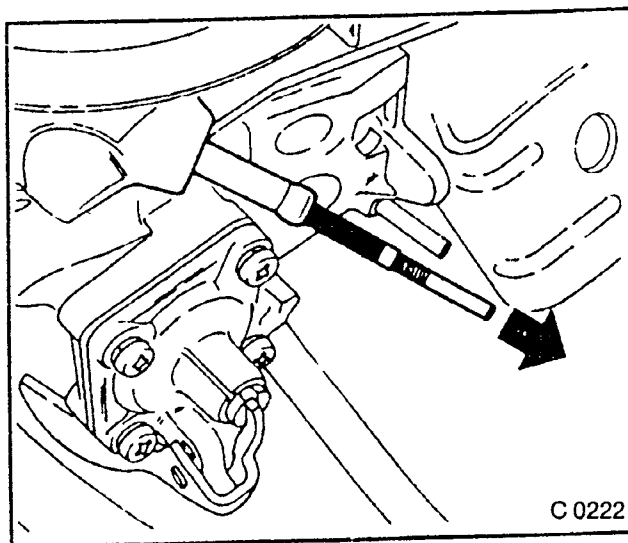


Fig. 227

## Enrichment Pipe — Check and Adjust

Checking conditions — air cleaner hood removed.

### MEASURE

1. Distance between enrichment pipe (1) and pre-atomizer (2) — see Technical Data.
2. Outlet of enrichment pipe points vertically to centre of pre-atomizer.

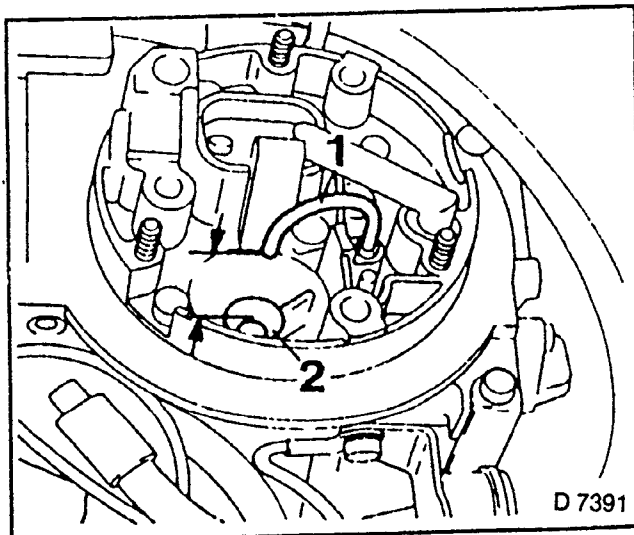


Fig. 228



# Trouble-shooting Chart (2 E 3 Carburettor)

## COMPLAINTS

Cold start (starting)															
Warming up (stalling after cold start)															
Cold idling (speed too high/too low)															
Cold driving characteristics, transition cold (pick-up poor, jerking)															
Automatic choke cuts out incompletely or late															
Warm start (starting time over 5 s)															
Idling (uneven, too high, too low)															
Idling speed or CO content too high (cannot be adjusted)															
Transition when accelerating (jerking)															
Transition at high engine speeds (to 2nd stage)															
Backfiring during coasting															
Performance (too low, missing at full load)															
Fuel consumption too high															
Idle speed (no warming up)															
<b>CAUSE</b>															
<b>REMEDY</b>															
●													Choke valve does not close completely	Adjust choke/check bi-spring	
●	●	●	●	●							●	●	Choke valve or accelerator difficult to move or jamming	Free	
	●	●	●									●	Choke valve gap incorrect	Adjust	
●	●	●	●									●	Pulldown unit leaky or defective	Check, replace if necessary	
		●	●	●								●	●	Choke heating, intake manifold preheater and thermo switch not in order, coolant flow disturbed	Check heating coil, thermo switch and contacts: check coolant flow
●	●	●	●			●							●	Stepped disc jamming; wrong position return springs defective	Free or adjust, replace carburettor cover if necessary
●	●	●											●	Cold start adjustment, throttle valve gap incorrect	Adjust fast idle or throttle valve gap
		●	●		●	●	●		●			●	●	Idle fuel air nozzle dirty	Clean, replace if necessary
					●	●	●		●				●	Idle adjustment incorrect	Correct
												●	●	Enrichment tube incorrect, bent	Check, adjust if necessary
						●						●	●	Throttle valve dashpot jams or incorrectly adjusted	Replace or adjust
●	●	●	●			●	●	●	●			●	●	Dirt in carburettor	Clean carburettor, if necessary replace
		●	●									●	●	Icing	Change fuel, check air filter preheater

- Note:
- Pre-requisites for the use of this chart are:
- 1 Perfect functioning of the engine. (timing, valves, etc )
  - 2 Ignition system and adjustment in perfect condition
  - 3 Leak — free intake system
  - 4 Exhaust system in perfect condition
  - 5 Correct control of intake air pre-heating
  - 6 Clean air filter
  - 7 Fuel pressure to carburettor correct.

# Trouble-shooting Chart (2 E 3 Carburettor)

## COMPLAINTS

- Cold start (starting)
  - Warming up (stalling after cold start)
    - Cold idling (speed too high/too low)
      - Cold driving characteristics, transition cold (pick-up poor, jerking)
        - Automatic choke cuts out incompletely or too late
          - Warm start (starting time over 5 s)
            - Idling (uneven, too high, too low)
              - Idling speed or CO content too high (cannot be adjusted)
                - Transition when accelerating (jerking)
                  - Transition at high engine speeds (to 2nd stage)
                    - Backfiring during coasting
                      - Performance (too low, missing at full load)
                        - Fuel consumption too high
                          - Idle speed (no warming up)

|   |   |   |   |  |   |   |   |   |  |   |   |   | CAUSE  | REMEDY   |
|---|---|---|---|--|---|---|---|---|--|---|---|---|--|--|
|   |   |   |   |  |   |   |   |   |  |   |   |   | Fuel evaporates (over-rich supply to engine) | Depress pedal fully and start/change to different type of fuel |
|   |   |   | ● |  |   |   |   |   |  |   |   |   | Injection quantity                           | Check, adjust if necessary                                     |
|   |   |   |   |  |   |   | ● | ● |  |   |   |   | Enrichment valve defective                   | Replace  |
| ● | ● |   |   |  | ● | ● | ● |   |  |   |   |   | Float needle valve leaky                     | Clean valve, replace needle if necessary                       |
|   |   |   |   |  | ● | ● | ● |   |  |   |   |   | Float defective/level incorrect              | Replace float  |
| ● | ● | ● | ● |  |   |   |   | ● |  |   |   |   | False air at gasket or flange                | Replace gaskets  |
|   |   |   |   |  |   |   |   |   |  |   |   |   | Throttle valve does not fully open           | Correct acceleration actuation                                 |
|   |   |   |   |  |   |   |   |   |  | ● | ● |   | Vacuum unit 2nd stage leaky                  | Replace  |
|   |   |   |   |  |   |   |   |   |  | ● | ● | ● | Nozzles not as prescribed                    | Replace nozzles  |
| ● | ● | ● |   |  | ● |   |   |   |  |   |   |   | Operating fault                              | Start as prescribed  |
|   |   |   |   |  |   |   |   |   |  |   |   |   | Driving conditions                           | Consumption check; explain to customer                         |
|   |   |   |   |  |   |   |   |   |  |   |   |   | ● Idle cut-off valve defect                  | Replace  |

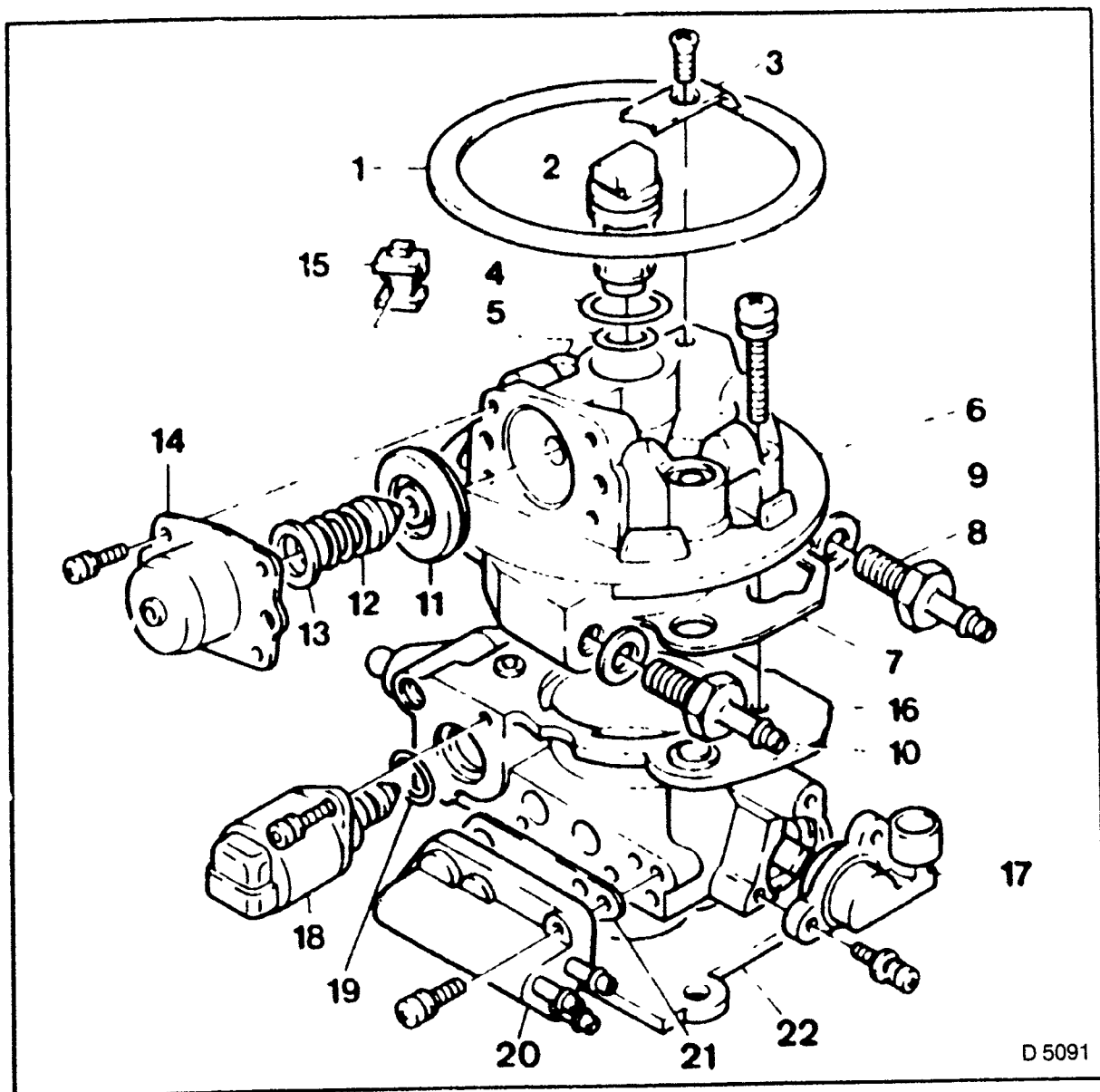


Fig. 229

## MULTEC CENTRAL FUEL INJECTION (C 16 NZ)

### Arrangement of Throttle Valve Injection Housing

1. Gasket.
2. Injection valve.
3. Injection valve bracket.
4. Injection valve upper O-Ring.
5. Injection valve lower O-Ring.
6. Throttle valve injection housing upper part.
7. Gasket for upper part of throttle valve injection housing.
8. Fuel inlet connection.
9. Fuel inlet connection gasket.
10. Fuel return connection.
11. Fuel pressure regulator diaphragm.
12. Fuel pressure regulator spring.
13. Fuel pressure regulator spring seating.
14. Fuel pressure regulator cover.
15. Connection cable rubber grommet.
16. Throttle valve part.
17. Throttle valve potentiometer.
18. Idle speed control stepper motor.
19. O-ring.
20. Flange for vacuum connections.
21. Flange gasket for vacuum connections.
22. Injection housing gasket for intake manifold.

D 5091

## General Information

The central fuel injection for the C 16 NZ engine is equipped with self-diagnosis. Faults that occur are stored as "trouble codes" and can be read out from the engine telltale as a blink code or with the TECH 1 Hand Tester.

### Control Unit — Remove and Install

#### REMOVE, DISCONNECT

1. Ground lead from battery.
2. Right front footwell panelling.
3. Storage compartment.
4. Bracket with control unit (1).
5. Wiring harness plug.
6. Control unit from bracket.

#### NOTE:

**CONTROL UNIT DEFECTIVE:  
REPLACE CONTROL UNIT  
COMPLETELY.**

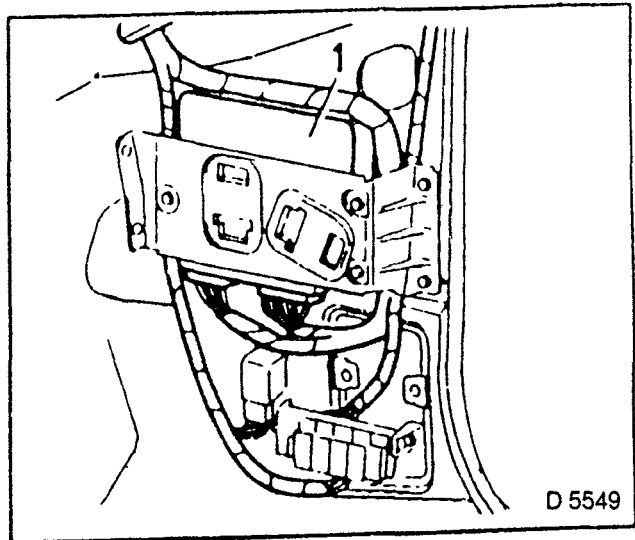


Fig. 230

#### INSTALL, CONNECT

1. Control unit to bracket.
2. Wiring harness plug.
3. Control unit with bracket.
4. Footwell panelling.
5. Storage compartment.
6. Ground lead to battery.

#### INSPECT

Carry out function check according to trouble-shooting programme.  
If code 51 appears or the engine telltale flashes constantly when no code is signalled, either the program memory is not in perfect condition (pin bent) or the control unit is defective.

## Throttle Valve Injection Housing — Remove and Install

### REMOVE, DISCONNECT

- 1 Air cleaner hood.
- 2 Injection valve rubber grommet.
- 3 All wiring harness plugs.
- 4 Fuel lines from connections on throttle valve injection housing.
- 5 Vacuum connections from vacuum connections flange.
- 6 Actuation rod.
- 7 Throttle valve injection housing from intake manifold.

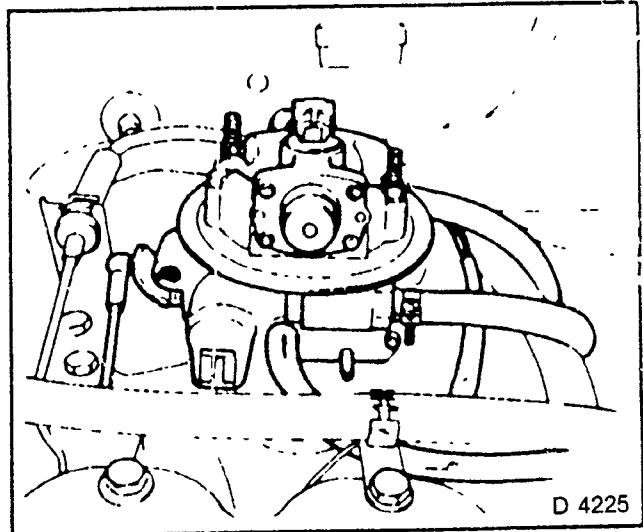


Fig. 231

### WARNING:

**NOTE SAFETY MEASURES AND NATIONAL REGULATIONS. FUEL SYSTEM IS UNDER PRESSURE. REMOVE FUEL PUMP RELAY. START ENGINE FOR AT LEAST FIVE SECONDS — PRESSURE REDUCTION.**

### TIGHTEN (TORQUE)

1. Throttle valve injection housing to intake manifold — 22 Nm.
2. Insert nuts with Locking Compound (Loctite 242).
3. Install new injection housing gasket — intake manifold, all lines and plug connectors in reverse order.

### NOTE:

**DO NOT MIX UP VACUUM HOSES.  
1 = INTAKE AIR PRE-HEATING  
2 = EXHAUST GAS RECIRCULATION**

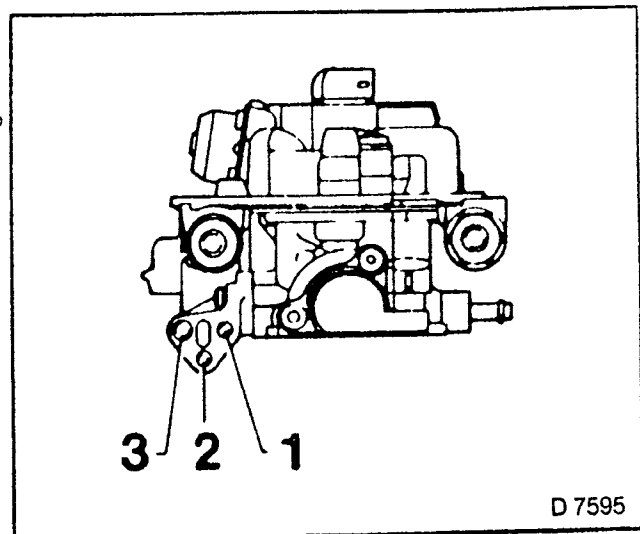


Fig. 232

## Throttle Valve Potentiometer — Remove and Install

### REMOVE, DISCONNECT

1. Air cleaner cover
2. Wiring harness plug.
3. Throttle valve potentiometer.

### TIGHTEN (TORQUE)

1. Throttle valve closed.
2. Potentiometer to throttle valve injection housing — 2,0 Nm.  
Note proper seating of carrier on throttle valve shaft.
3. Insert bolts with Locking Compound (Loctite 242).

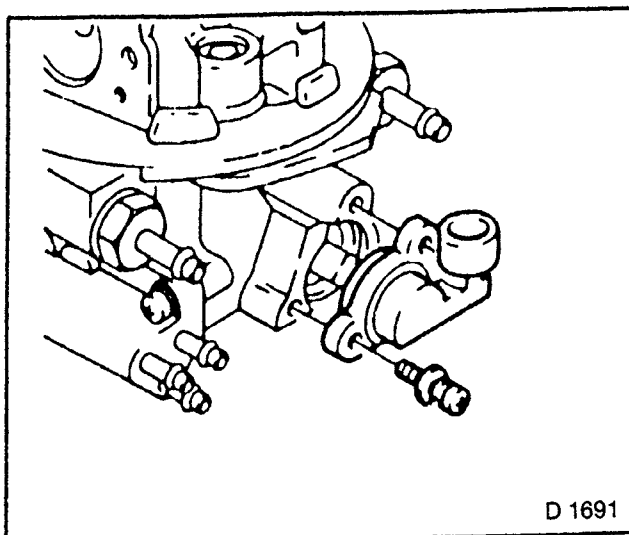


Fig. 233

## Injection Valve, Remove and Install

### REMOVE, DISCONNECT

1. Air cleaner cover.
2. Wiring harness plug from injection valve.
3. Bolt with bracket.
4. Injection valve carefully from throttle valve injection housing.

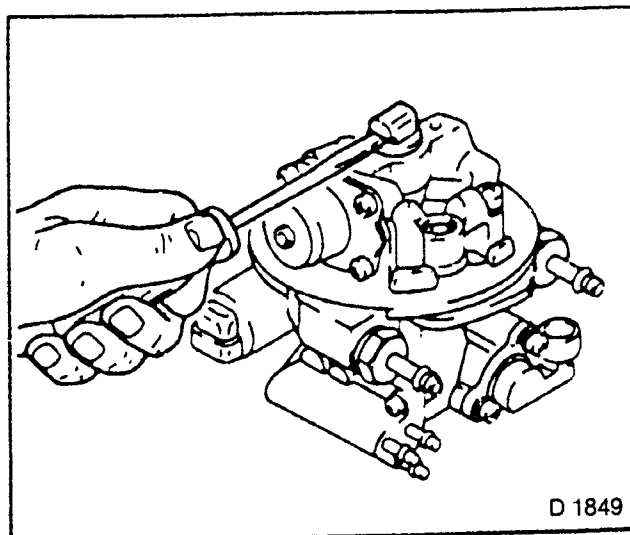


Fig. 234

### INSTALL, CONNECT

1. Injection valve — new seal rings.
2. Electrical plug part points towards bracket bolt.
3. Wiring plug to injection valve.
4. Air cleaner cover.

### TIGHTEN (TORQUE)

1. Bracket bolt to throttle valve injection housing — 3,0 Nm.
2. Install with Locking Compound (Loctite 242).

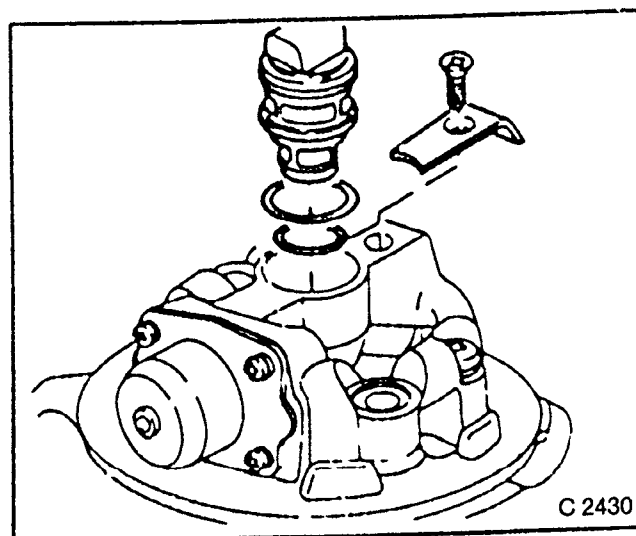


Fig. 235

## Fuel Pressure Regulator, Fuel Pressure Regulator Diaphragm — Remove and Install

### WARNING

#### NOTE SAFETY MEASURES AND NATIONAL REGULATIONS.

Fuel system is under pressure.

1. Remove fuel pump relay.
2. Start engine for at least five seconds — pressure reduction if the fuel pressure regulator cover becomes detached the diaphragm must be replaced.

### REMOVE, DISCONNECT

1. Air cleaner cover.
2. Cover.
3. Spring and diaphragm.

### INSTALL, CONNECT

1. Diaphragm.
2. Spring.
3. Cover  
Diaphragm must sit in groove of fuel injection throttle valve housing.
4. Air cleaner cover.

### TIGHTEN (TORQUE)

1. Fuel pressure regulator to throttle valve injection housing — 2,5 Nm.
2. Insert bolts with Locking Compound (Loctite 242).

## Fuel Pressure — Check

### WARNING

#### FUEL ESCAPES NOTE SAFETY MEASURES AND NATIONAL REGULATIONS.

Fuel system is under pressure.

1. Remove fuel pump relay.
2. Start engine for at least five seconds — pressure reduction.

### INSTALL, CONNECT

1. Fuel Pressure Gauge MKM-588 into fuel feed line (1).

### INSPECT

1. Fuel pressure — nominal value:  
1,0 bar/14,5 psi.

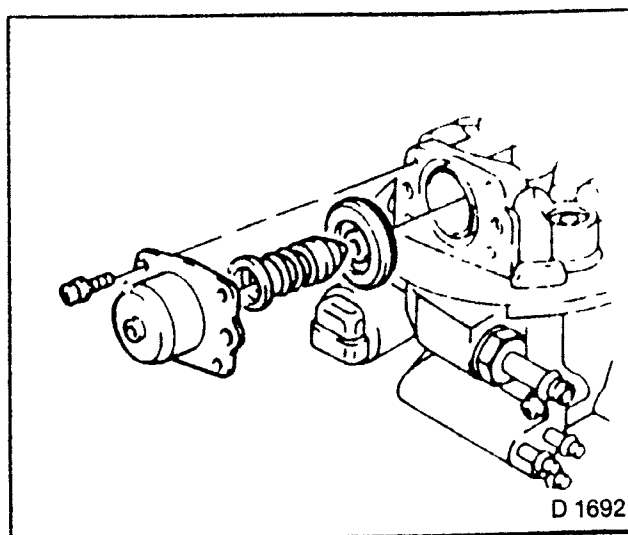


Fig. 236

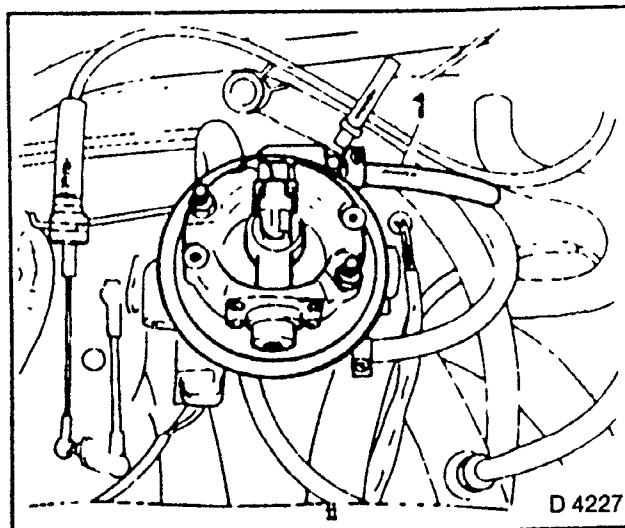


Fig. 237

## Throttle Valve Injection Housing Upper Part — Remove and Install

REPLACING CONVERT INJECTION VALVE, FUEL CONNECTIONS AND FUEL PRESSURE REGULATOR.

### REMOVE, DISCONNECT

1. Air cleaner hood.
2. Injection valve wiring harness plug.
3. Injection valve rubber grommet.
4. Fuel lines.
5. Upper part — two bolts and nuts.

### INSTALL, CONNECT

1. Fuel lines — use new gaskets.
2. Injection valve rubber grommet.
3. Injection valve wiring harness plug.
4. Air cleaner hood.

### TIGHTEN (TORQUE)

1. Upper part to throttle valve injection housing — 6 Nm.
2. Throttle valve injection housing to intake manifold — 22 Nm.
3. Use new gasket.
4. Insert bolts and nuts with Locking Compound (Loctite 242).

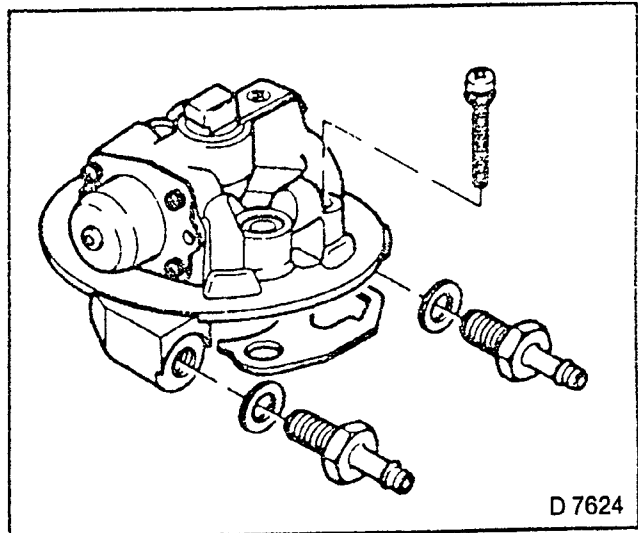


Fig. 238

## Idle Air Control Stepper Motor — Remove and Install

### REMOVE, DISCONNECT

1. Air cleaner cover.
2. Wiring harness plug.
3. Idle air control stepper motor.

### NOTE:

TO AVOID DAMAGING HOUSING DURING INSTALLATION, THE DISTANCE BETWEEN PISTON AND FLANGE SHOULD BE NOT LARGER THAN 28 mm (1) IF THERE IS A VARIATION, PRESS IN PISTON CAREFULLY TO STOP.

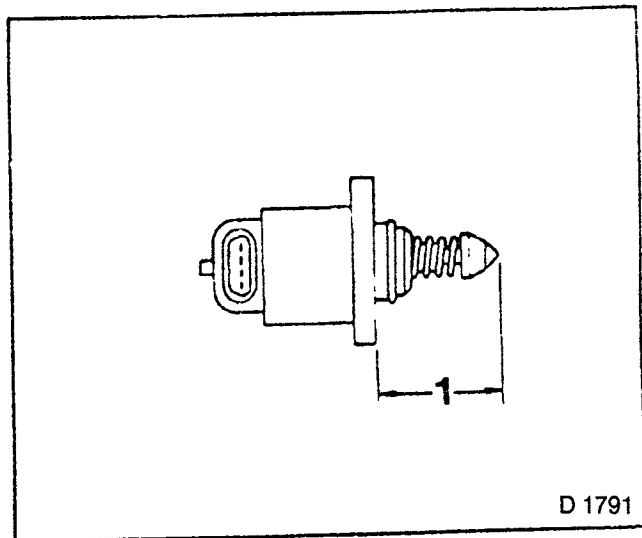
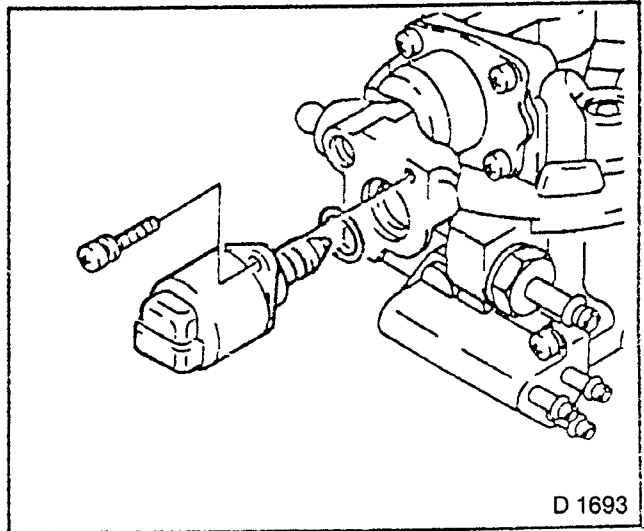


Fig. 239



**TIGHTEN (TORQUE)**

1. Idle air control stepper motor to throttle valve injection housing — 2,5 Nm.
2. New rubber O-ring, install bolts with Locking Compound (Loctite 242).
3. Air cleaner cover.



D 1693

Fig. 240

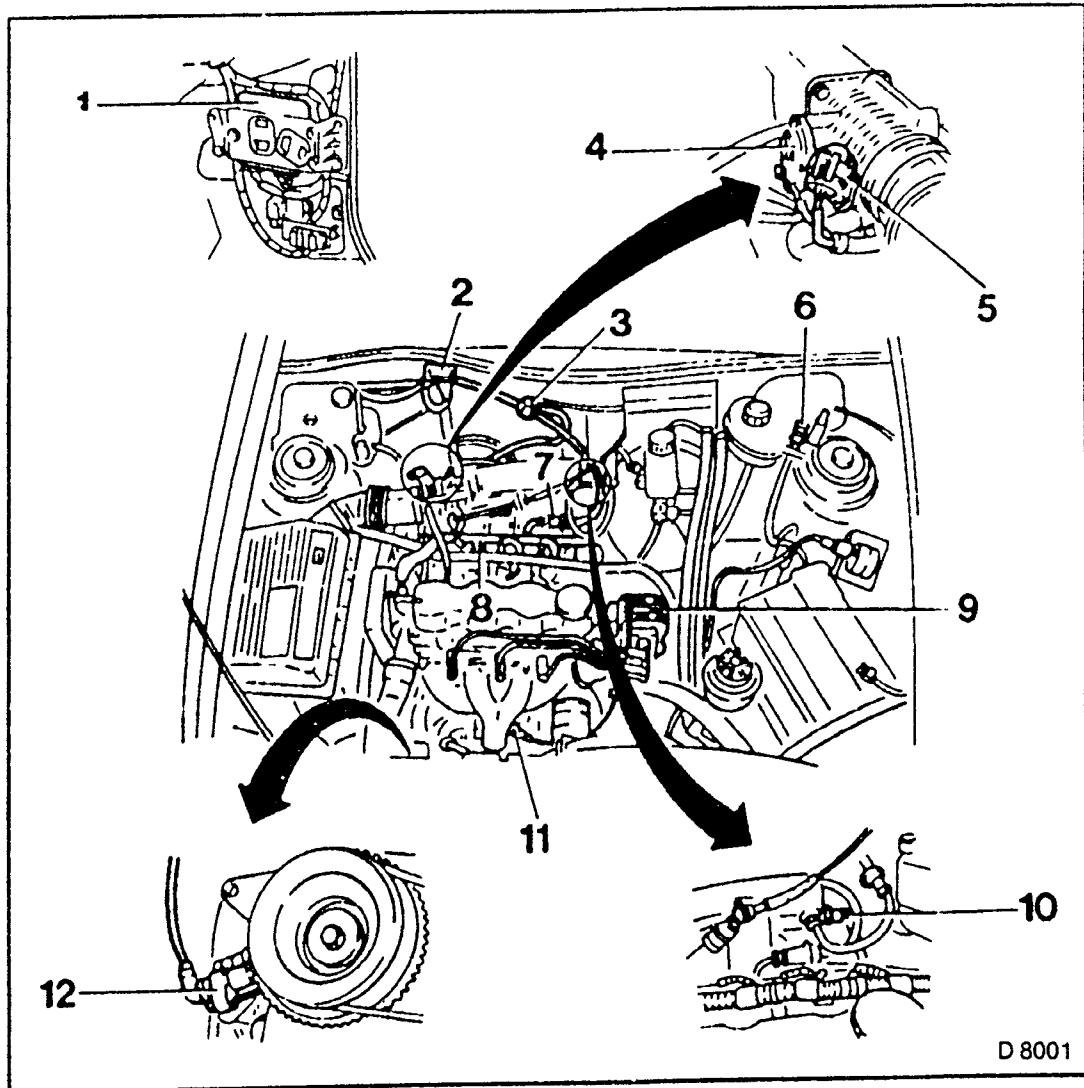


Fig 241

## Motronic M 1.5.4

1. Control unit.
2. Intake manifold pressure sensor.
3. Tank vent valve. (N/A Delta).
4. Throttle valve potentiometer.
5. Idle speed control stepper motor.

6. Octane number plug.
7. Fuel pressure regulator.
8. Injection valves.
9. Dual spark ignition distributor.
10. Intake air temperature sensor.
11. C.O. Potentiometer.
12. Inductive pulse pick-up.

D 8001

## Throttle Valve Potentiometer — Remove and Install

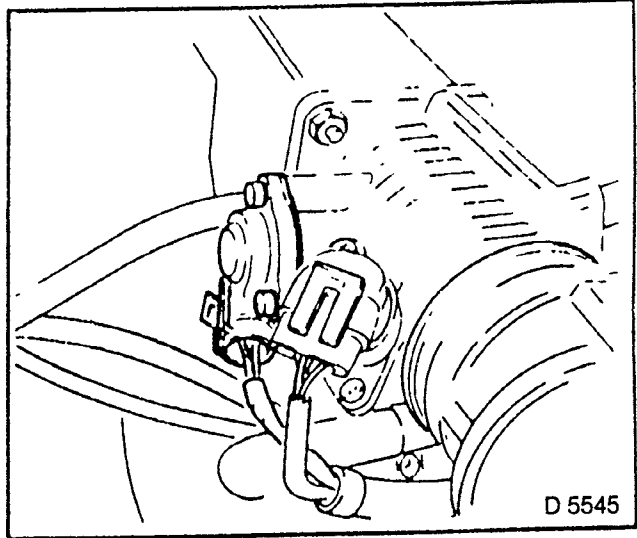
### REMOVE, DISCONNECT

1. Wiring harness plug for throttle valve potentiometer.
2. Throttle valve potentiometer.

### INSTALL, CONNECT

1. Throttle valve potentiometer.
2. Wiring harness plug for throttle valve potentiometer.

Note proper seating.



D 5545

Fig. 242

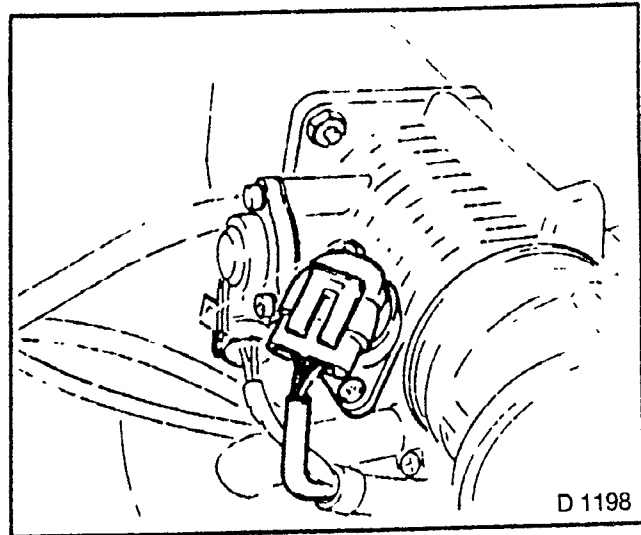
## Idle Air Control Stepper Motor — Remove and Install

### REMOVE, DISCONNECT

1. Wiring harness plug for idle air control stepper motor.
2. Idle air control stepper motor.
3. Seal ring.

### INSTALL, CONNECT

1. Seal ring.
2. Idle air control stepper motor.
3. Wiring harness plug for idle air control stepper motor.

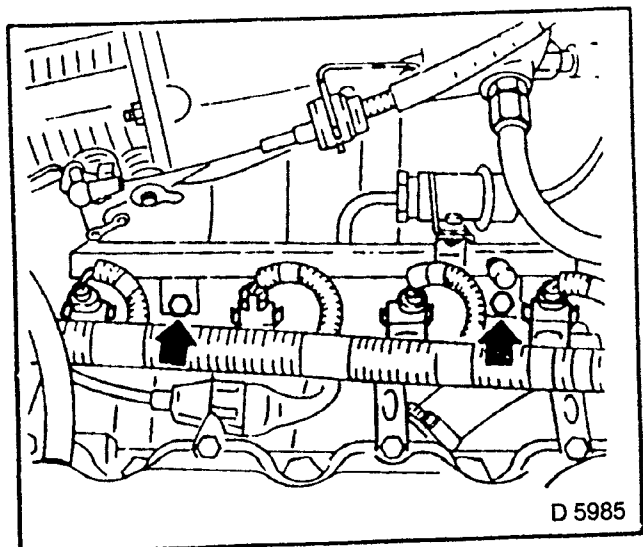


D 1198

Fig. 243

### INSTALL, CONNECT

1. Injection valve with new seal rings into fuel distributor pipe.
2. Injection valve spring clamp.
3. Fuel distributor pipe to intake manifold.
4. Injection valve wiring harness plug.
5. Ground cable to battery.



D 5985

Fig. 244

## Fuel Pressure — Check

### INSTALL, CONNECT

- 1 Fuel Pressure Gauge KM-J-34740-91 to fuel distributor pipe.

### INSPECT

1. Fuel pressure.  
Nominal value: 3 bar/43,5 psi

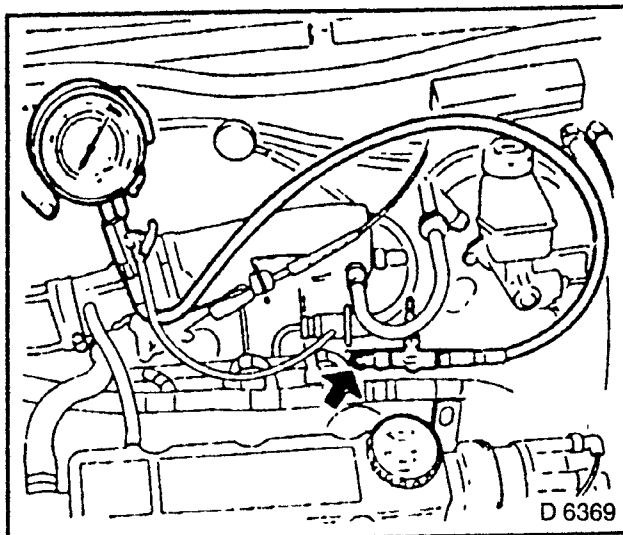


Fig. 245

## Fuel Pressure Regulator — Remove and Install

### REMOVE, DISCONNECT

1. Vacuum hose from fuel pressure regulator.
2. Fuel line from fuel pressure regulator — counterhold with suitable open-ended wrench.
3. Fuel pressure regulator.

### WARNING:

**FUEL ESCAPES  
NOTE SAFETY MEASURES AND  
NATIONAL REGULATIONS.**

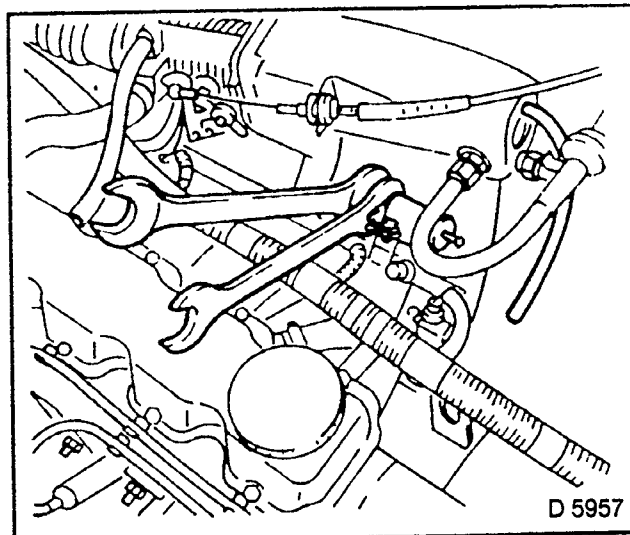


Fig. 246

### INSTALL, CONNECT

1. Fuel pressure regulator — tightening torque 8 Nm.
2. Use new seal rings.
3. Fuel line to fuel pressure regulator.
4. Vacuum hose to fuel pressure regulator.

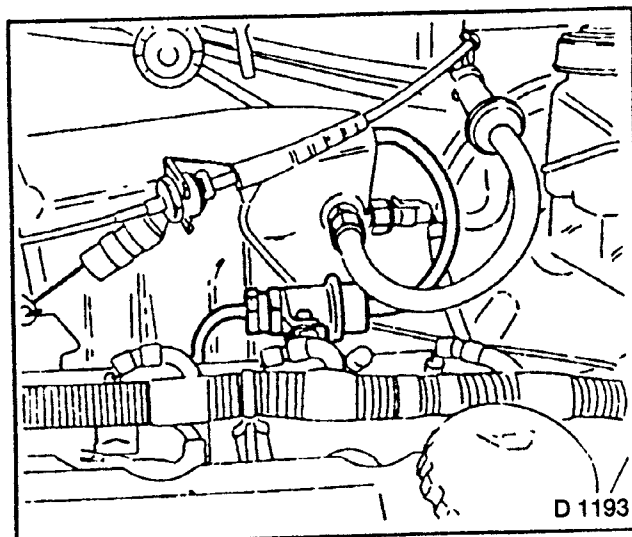
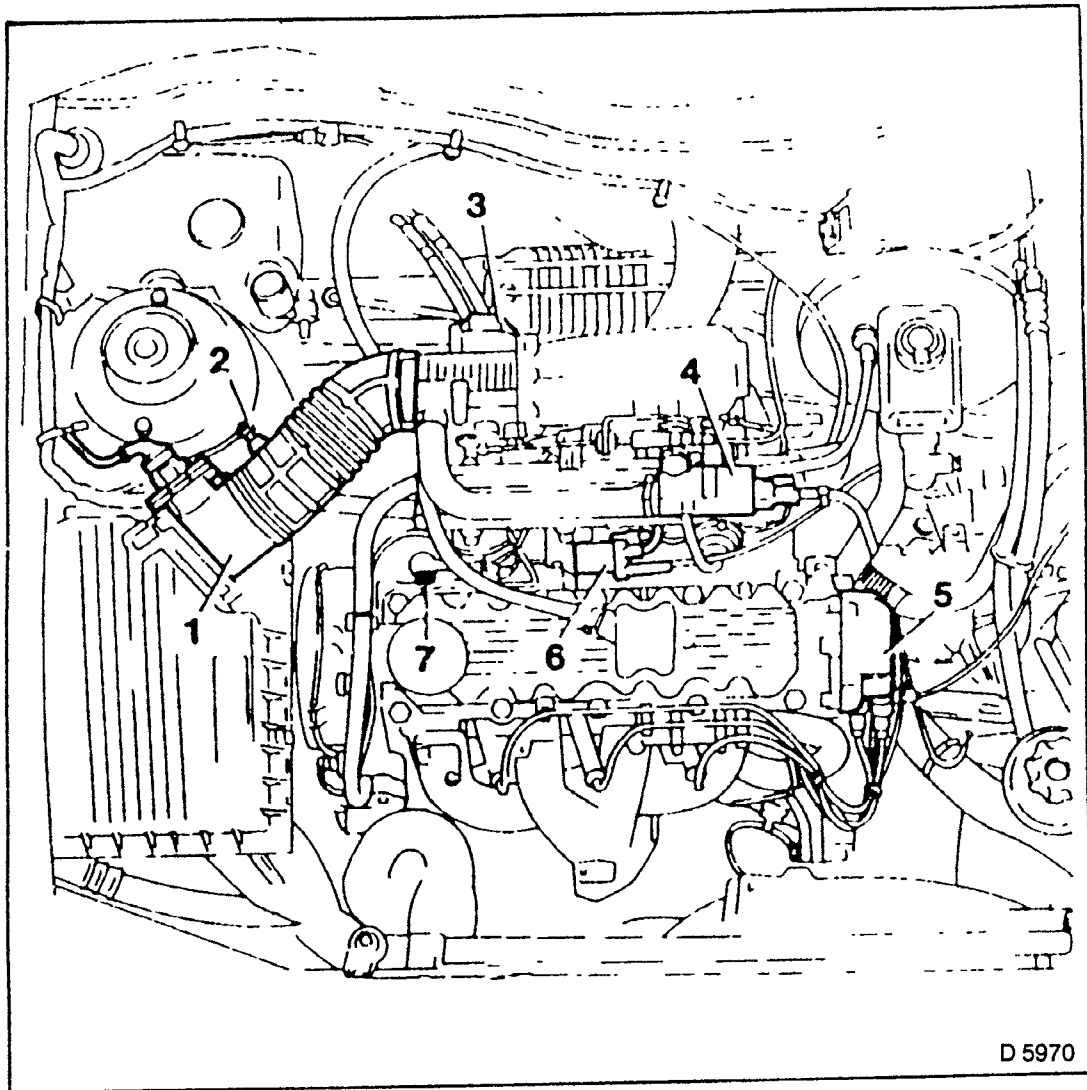


Fig. 247



D 5970

Fig. 248

### **Motronic M 1.5.4 (18 SE/20 SEH)**

- 1. (Hot film) mass air flow sensor.
- 2. Intake air temperature sensor.
- 3. Throttle valve potentiometer.
- 4. Idle speed adjuster.
- 5. High voltage distributor.
- 6. Tank vent valve.
- 7. Coolant temperature sensor.



## Hot Film Mass Air Flow Meter — Remove and Install

### REMOVE, DISCONNECT

1. Intake air temperature sensor wiring plug.
2. Hot film mass air flow meter wiring plug.
3. Air intake hose.
4. Upper part of air cleaner with hot film mass air flow meter.

### NOTE:

**DO NOT DISASSEMBLE HOT FILM MASS AIR FLOW METER. REMOVE AND INSTALL AS COMPLETE UNIT ONLY.**

**IF EXTERNAL DAMAGE (E.G. DEFORMATION OF THE GRILLE) IS APPARENT, REPLACE HOT FILM MASS AIR FLOW METER.**

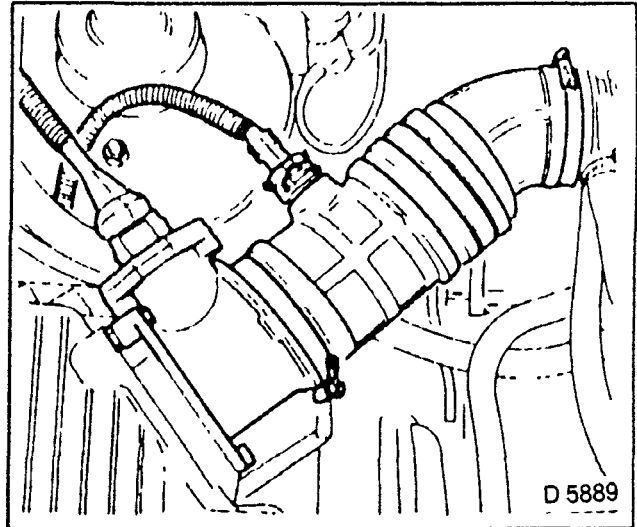


Fig. 249

### REMOVE, DISCONNECT

1. Hot film mass air flow meter with seal ring from upper part of air cleaner.

### INSTALL, CONNECT

1. Hot film mass air flow meter with new seal ring. Insert two bolts with Locking Compound (Loctite 242).
2. Upper part of air cleaner with hot film mass air flow meter.
3. Air intake hose.
4. Intake air temperature sensor wiring plug.
5. Hot film mass air flow meter wiring plug.

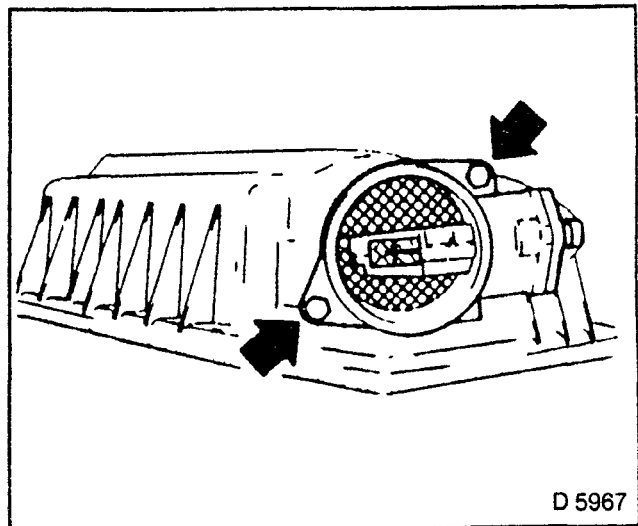


Fig. 250

## Fuel Pressure Regulator — Remove and Install

### WARNING:

**FUEL ESCAPES.  
NOTE SAFETY MEASURES AND  
NATIONAL REGULATIONS**

### REMOVE, DISCONNECT

1. Vacuum hose.
2. Fuel hoses.
3. Fuel pressure regulator.

### INSTALL, CONNECT

1. Fuel pressure regulator.
2. Fuel hoses.
3. Vacuum hose.

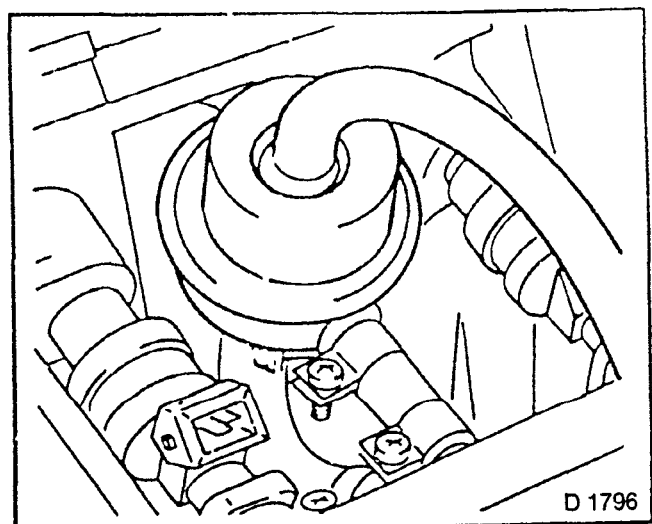


Fig. 251

## Idle Speed Adjuster — Remove and Install

### REMOVE, DISCONNECT

1. Wiring harness plug for idle speed adjuster.
2. Hose clamps.
3. Idle speed adjuster.

### INSTALL, CONNECT

1. Idle speed adjuster.
2. Hose clamps.
3. Wiring harness plug for idle speed adjuster — ensure good condition and firm seat of hoses and hose clamps.

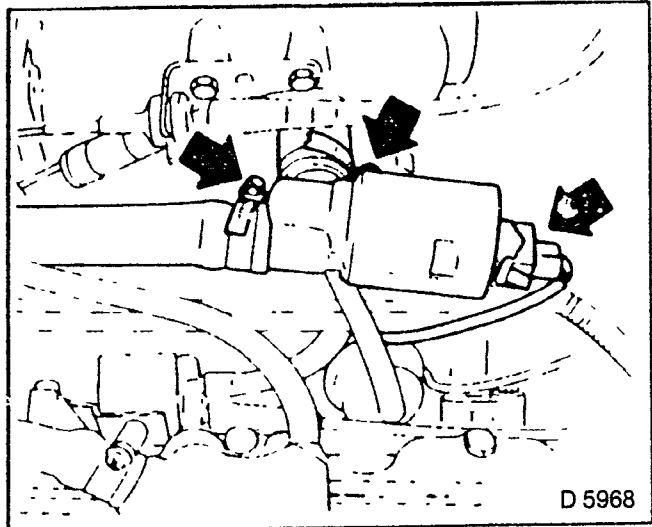


Fig. 252

## Throttle Body — Remove and Install

### REMOVE, DISCONNECT

1. Wiring harness plug for intake air temperature sensor.
2. Air intake hose.

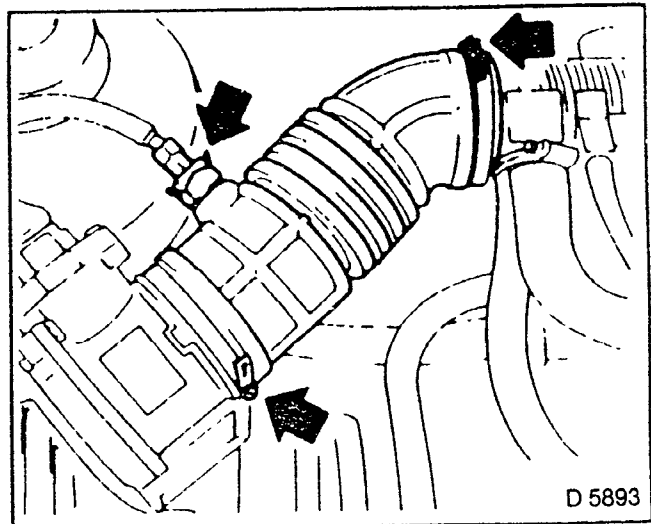


Fig. 253

### REMOVE, DISCONNECT

1. Idle speed adjuster hose.
2. Crankcase ventilation hoses.
3. Tank vent valve vacuum hose.
4. Wiring harness plug for throttle valve potentiometer.
5. Coolant hoses.
6. Throttle body with gasket.

### NOTE:

**COOLANT ESCAPES  
PLACE COLLECTING BASIN  
UNDERNEATH.**

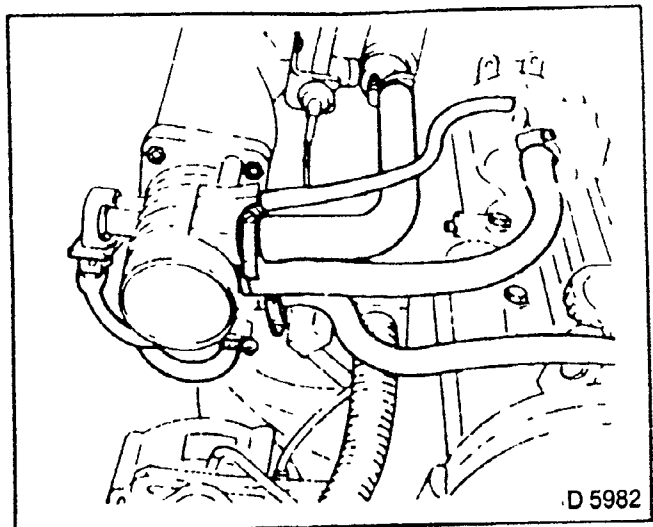


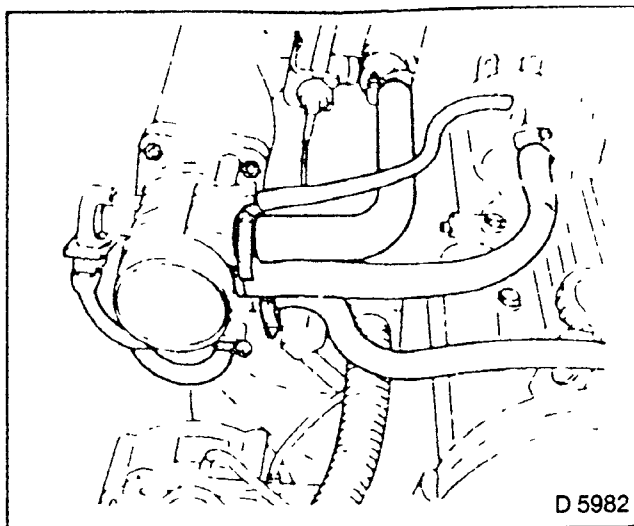
Fig. 254

**CLEAN**

Sealing surfaces.

**INSTALL, CONNECT**

1. Throttle body with new gasket.
2. Wiring harness plug for throttle valve potentiometer.
3. Tank vent valve vacuum hose.
4. Coolant hoses.



D 5982

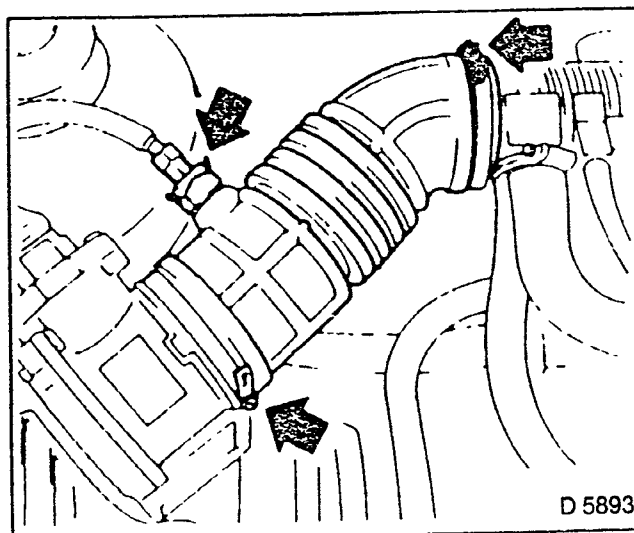
Fig 255

**INSTALL, CONNECT**

1. Air intake hose.
2. Wiring harness plug for intake air temperature sensor.
3. Idle speed adjuster hose.
4. Crankcase vent hoses.

**INSPECT**

1. Top up and bleed cooling system.
2. Ensure good condition and firm seat of hose connections.



D 5893

Fig. 256

**Fuel Pressure — Check****REMOVE, DISCONNECT**

1. Disconnect fuel feed line (Arrow)  
Fig. 257.

**WARNING:**

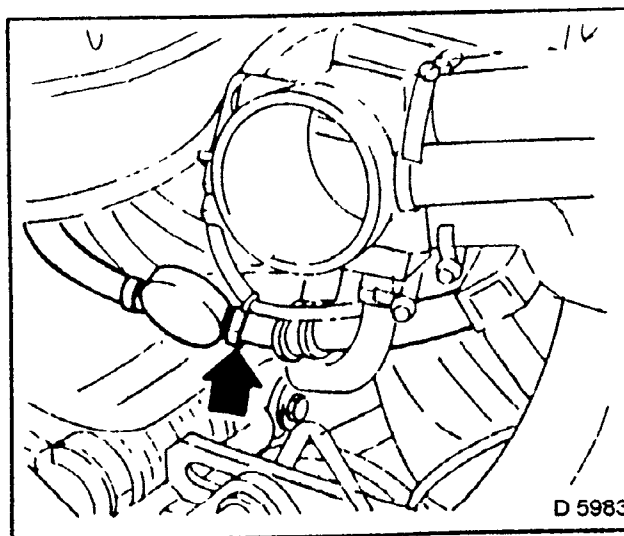
**FUEL ESCAPES.  
NOTE SAFETY MEASURES AND  
NATIONAL REGULATIONS.**

**INSTALL, CONNECT**

1. Fuel Pressure Gauge MKM-588 into fuel feed line.

**INSPECT**

1. Fuel pressure.
2. Vacuum hose for fuel pressure regulator.  
Connected: 1,8 — 2,2 bar.  
Disconnected: 2,5 — 3,0 bar.



D 5983

Fig. 257



## Tank Vent Valve — Remove and Install

### REMOVE, DISCONNECT

1. Tank vent valve wiring harness.
2. Hoses.
3. Close off hose to active carbon canister — spring clamp.
4. Tank vent valve (1).

### INSTALL, CONNECT

1. Tank vent valve (1).
2. Hoses — remove spring clamps.
3. Tank vent valve wiring plug.

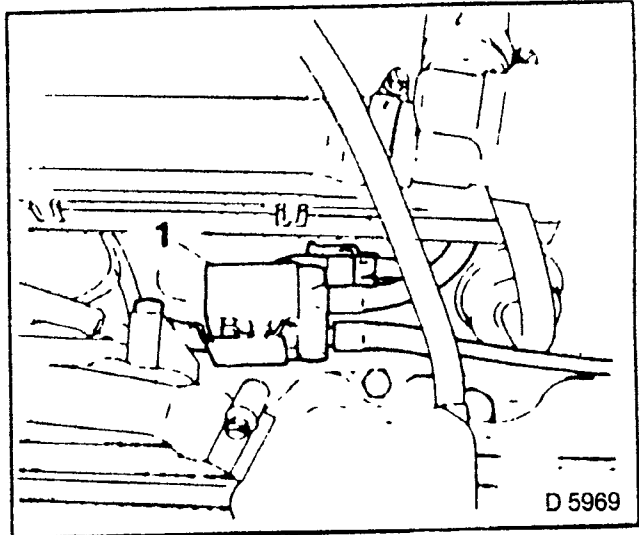


Fig. 258

## Injection Valves — Remove and Install

### REMOVE, DISCONNECT

1. Brake servo vacuum hose.
2. Diaphragm damper.
3. Plug strip for injection valves.
4. Idle speed adjuster.

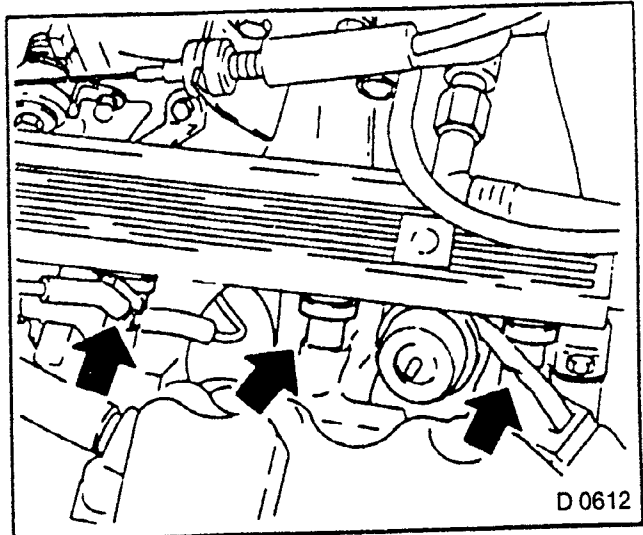


Fig. 259

### REMOVE, DISCONNECT

1. Four spring clamps for injection valves — screwdriver.

### WARNING:

**FUEL ESCAPES  
OBSERVE SAFETY MEASURES AND  
NATIONAL REGULATIONS.**

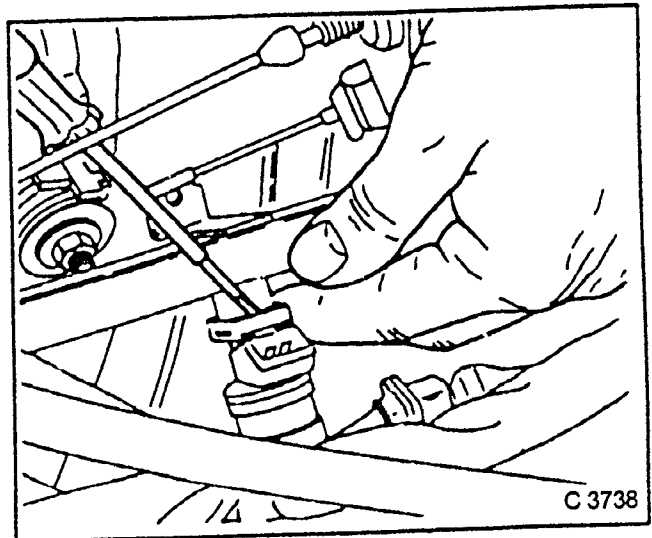


Fig. 260

**REMOVE, DISCONNECT**

1. Loosen fuel distributor pipe.
2. Fuel feed bracket.
3. Injection valve from distributor pipe.

**INSTALL, CONNECT**

1. Injection valve — new seal rings.
2. Retaining clips.
3. Fuel feed bracket.
4. Fuel distributor pipe.
5. Idle speed adjuster.
6. Plug strip for injection valves.
7. Diaphragm damper.
8. Brake servo vacuum hose.

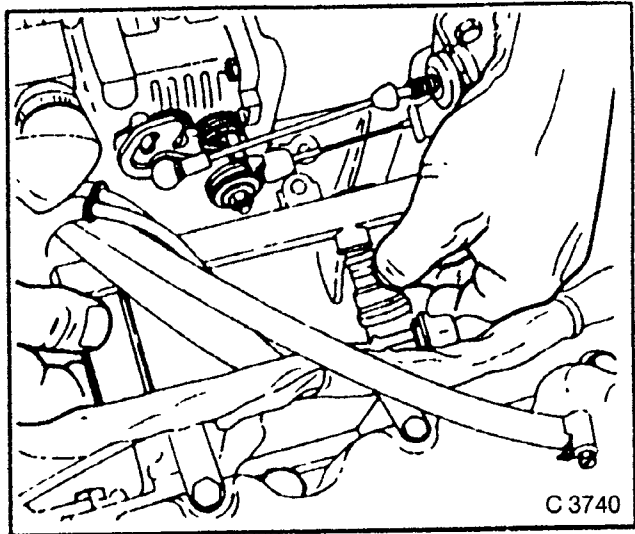


Fig. 261

**Throttle Valve Potentiometer — Remove and Install****REMOVE, DISCONNECT**

1. Wiring harness plug for throttle valve potentiometer.
2. Throttle valve potentiometer.

**INSTALL, CONNECT**

1. Throttle valve potentiometer.
2. Wiring harness plug for throttle valve potentiometer.
3. Note proper seating.

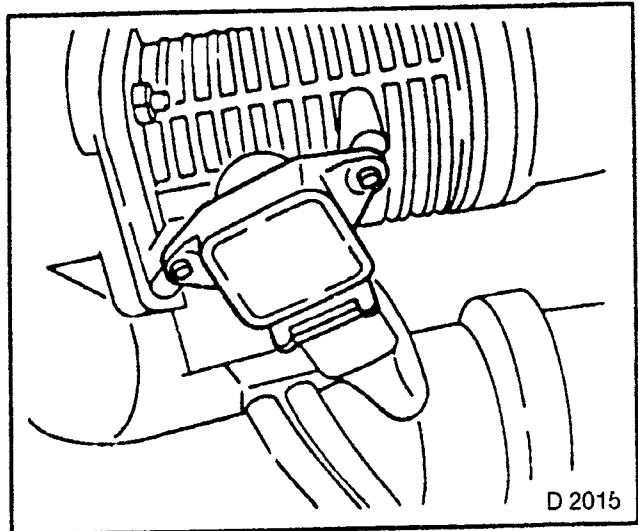


Fig. 262

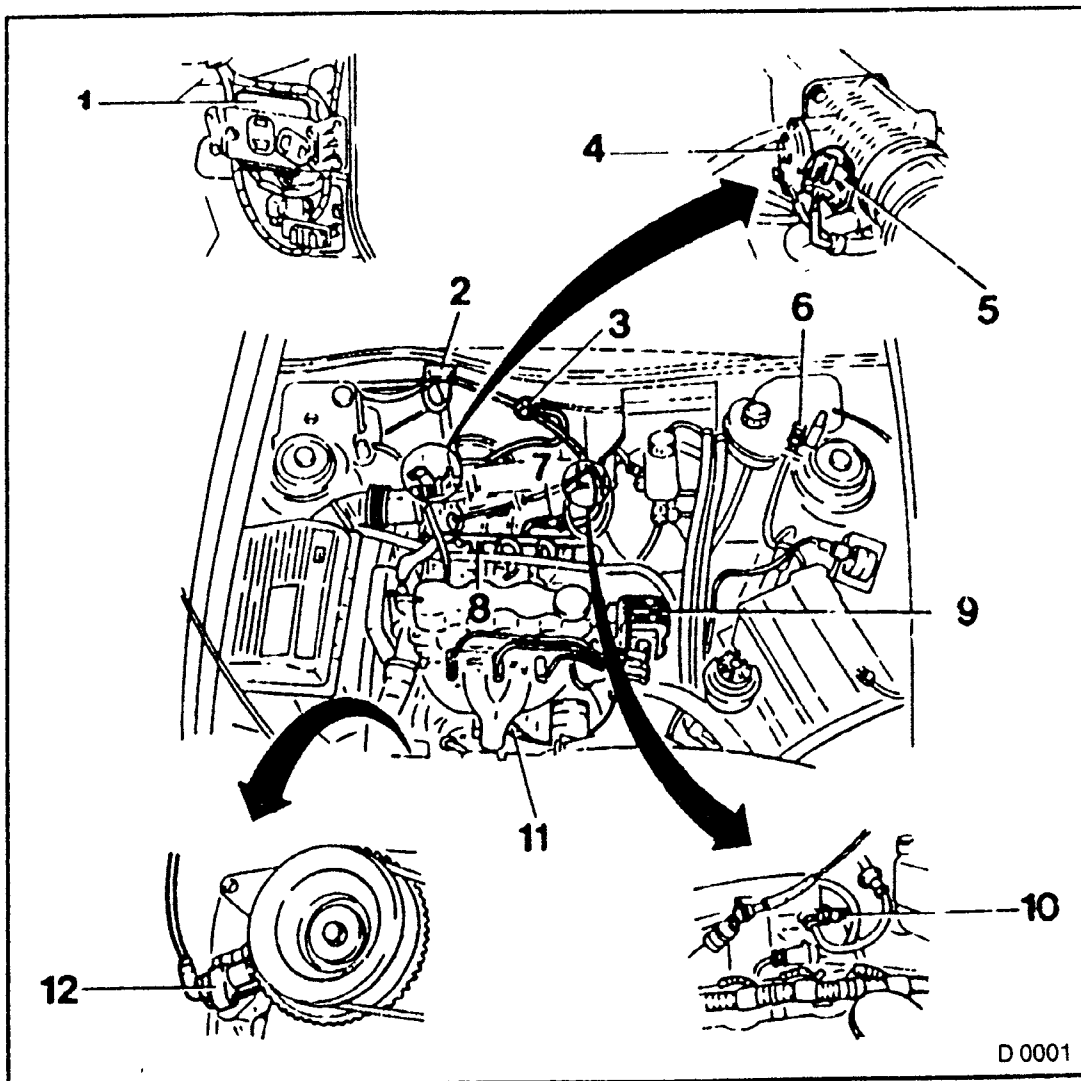


Fig 263

D 0001

## Bosch M1.5.4 (C 16 SE)

1. Control unit (installation position in right footwell).
2. Intake manifold pressure sensor.
3. Tank vent valve.
4. Throttle valve potentiometer.
5. Idle air control stepper motor.
6. Octane number plug.
7. Fuel pressure regulator.
8. Fuel distributor pipe with injection valves.
9. Dual spark ignition coil.
10. Intake air temperature sensor.
11. Oxygen sensor. (N/a to DMC).
12. Inductive pulse pick-up.

## Intake Air Temperature Sensor — Remove and Install (C 16 SE)

### REMOVE, DISCONNECT

1. Wiring harness plug for intake air temperature sensor.
2. Intake air temperature sensor.

### TIGHTEN (TORQUE)

1. Intake air temperature sensor to intake manifold — 27 Nm.
2. Intake air temperature sensor wiring plug.

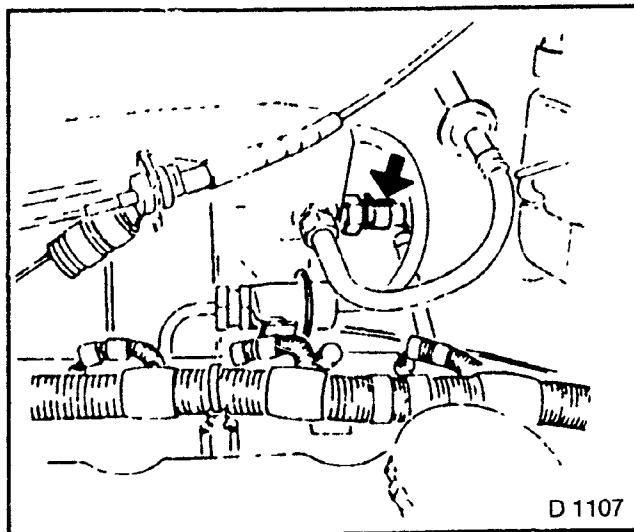


Fig. 264

## Coolant Temperature Sensor — Remove and Install (C 16 SE)

### REMOVE, DISCONNECT

1. Wiring harness plug for coolant temperature sensor.
2. Coolant temperature sensor.
3. Coolant escapes — place collecting pan underneath.

### TIGHTEN (TORQUE)

1. Coolant temperature sensor with new seal ring to cylinder head — 20 Nm.
2. Wiring harness plug for coolant temperature sensor.
3. Fill up and bleed cooling system.

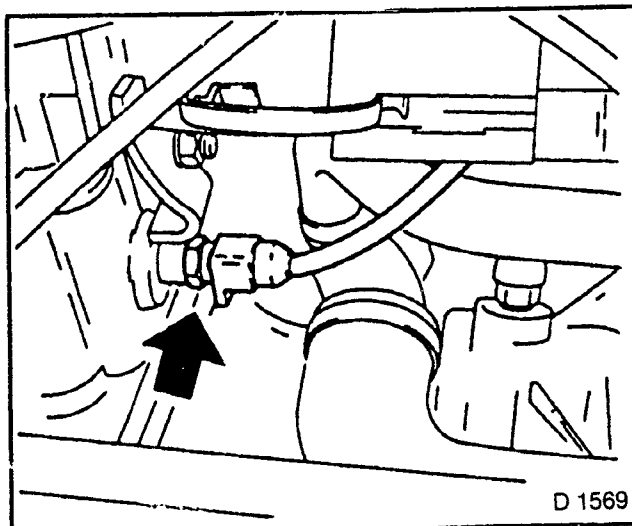


Fig. 265

## Intake Air Temperature Sensor — Remove and Install (16NZ/18SE/20 SEH)

### REMOVE, DISCONNECT

1. Wiring harness plug for intake air temperature sensor.
2. Air intake hose.
3. Intake air temperature sensor.

**WARNING:**  
DO NOT DAMAGE AIR INTAKE HOSE.

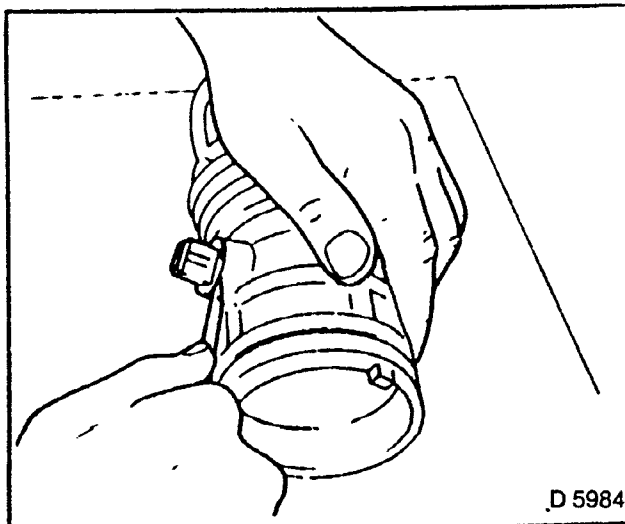


Fig. 266

**INSTALL, CONNECT**

1. Temperature sensor into air intake hose.
2. Note proper seating.
3. Air intake hose.
4. Wiring harness plug for intake air temperature sensor.

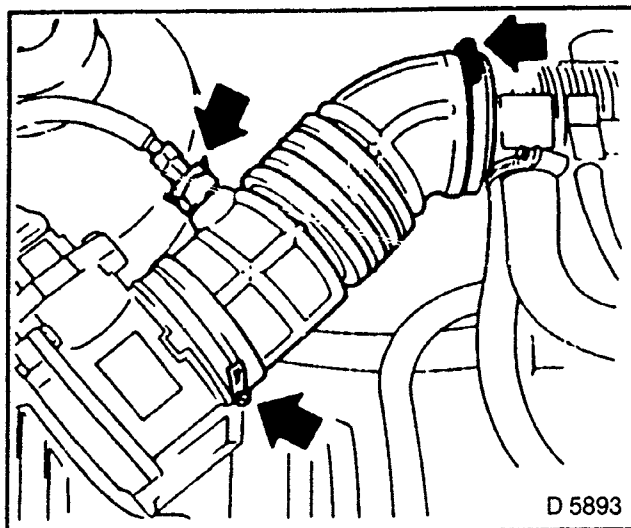


Fig. 267

**Coolant Temperature Sensor — Remove and Install (C 16 NZ)****REMOVE, DISCONNECT**

1. Wiring harness plug for coolant temperature sensor.
2. Coolant temperature sensor from intake manifold.

**NOTE:**  
**COOLANT ESCAPES.**

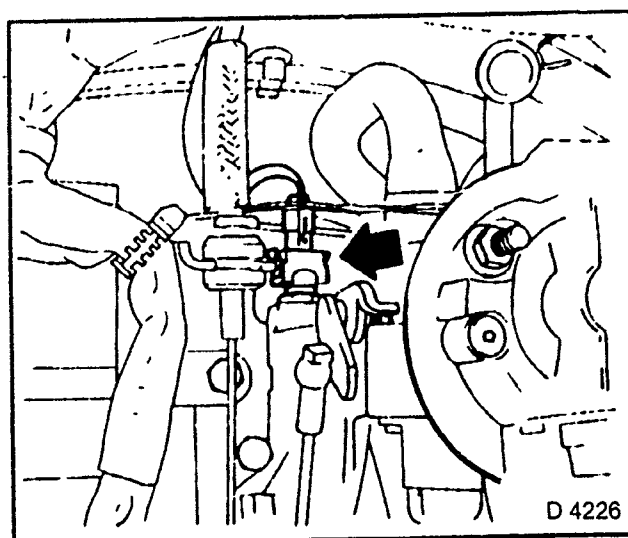


Fig. 268

**TIGHTEN (TORQUE)**

1. Coolant temperature sensor with new seal ring to intake manifold — 20 Nm.
2. Wiring harness plug for coolant temperature sensor.
3. Fill up and bleed cooling system.

# Coolant Temperature Sensor — Remove and Install (18 SE/20 SEH)

## REMOVE, DISCONNECT

- 1. Wiring harness plug for coolant temperature sensor.
- 2. Coolant temperature sensor.
- 3. Coolant escapes — place collecting basin underneath.

## TIGHTEN (TORQUE)

- 1. Coolant temperature sensor to intake manifold — 10 Nm.
- 2. Wiring harness plug for coolant temperature sensor.
- 3. Fill up and bleed cooling system.

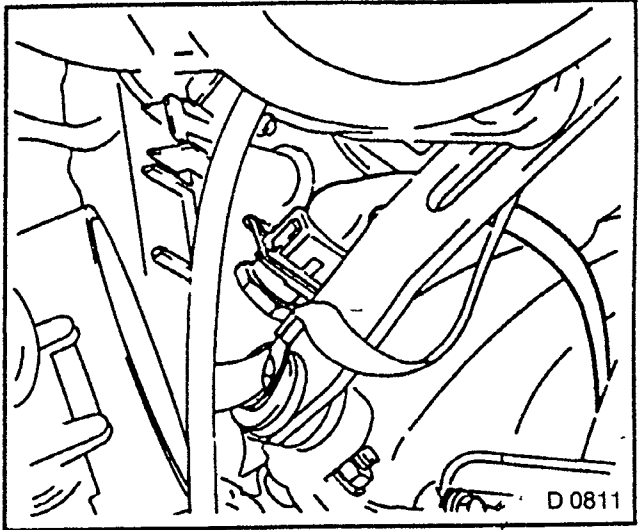


Fig. 269

# Control Unit — Remove and Install (18 SE/20 SEH)

## REMOVE, DISCONNECT

- 1. Turn off ignition.
- 2. Storage compartment.
- 3. Right footwell panelling.
- 4. Wiring harness plug.
- 5. Bracket with control unit.
- 6. Control unit from bracket.

## INSTALL, CONNECT

- 1. Control unit to bracket.
- 2. Bracket with control unit.
- 3. Wiring harness plug.
- 4. Footwell panelling.
- 5. Storage compartment.

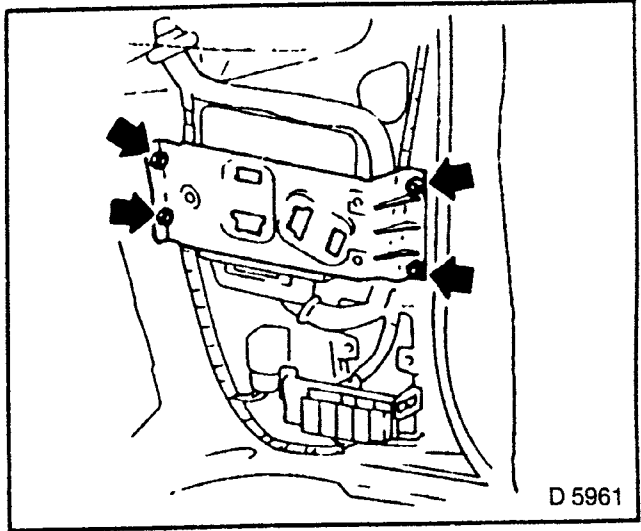


Fig. 270

# Control Unit — Remove and Install (C 16 SE)

## REMOVE, DISCONNECT

- 1. Switch off ignition.
- 2. Storage compartment.
- 3. Right footwell panelling.
- 4. Bracket with control unit.
- 5. Wiring harness plug.
- 6. Control unit (1) from bracket.

**NOTE:**  
**CONTROL UNIT CONSISTS OF TWO PARTS:**  
**BASIC CONTROL UNIT**  
**PROGRAMME MEMORY (PROM)**

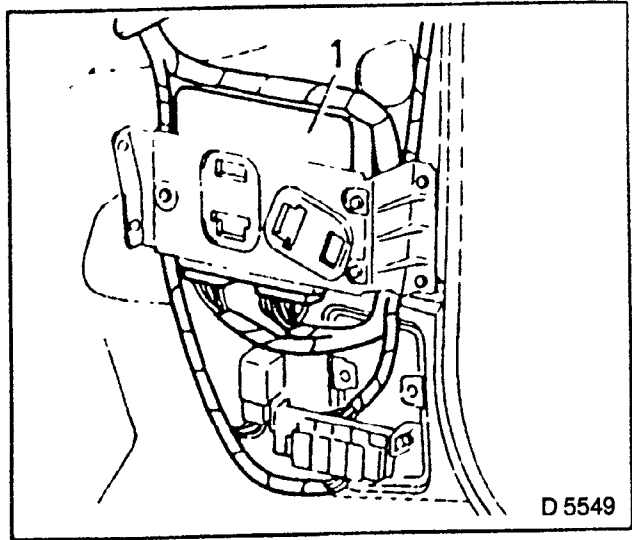


Fig. 271

**NOTE:**

**Control unit in order, programme memory defective:  
Install new programme memory in existing control unit.**

**Programme memory in order, control unit defective:**

**Install existing programme memory in new control unit from Service — it is supplied without programme memory.**

**DISASSEMBLE**

1. Control unit.
2. Remove programme memory cover.
3. Release programme memory and lift it out.

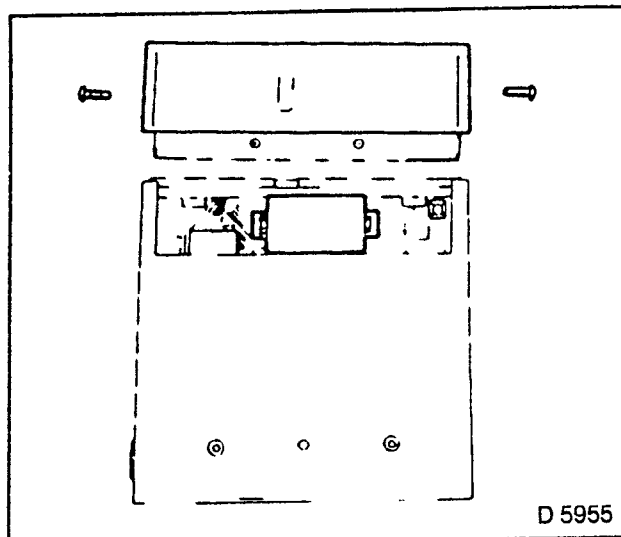


Fig. 272

## **Intake Manifold Pressure Sensor — Remove and Install (C 16 SE, C 16 NZ)**

**REMOVE, DISCONNECT**

1. Lift water deflector.
2. Vacuum hose.
3. Wiring harness plug.
4. Intake manifold pressure sensor.

**INSTALL, CONNECT**

1. Intake manifold pressure sensor.
2. Wiring harness plug.
3. Vacuum hose.
4. Water deflector.

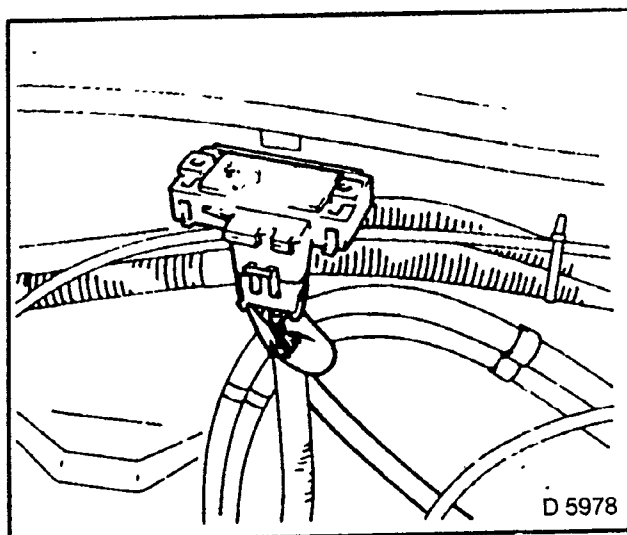


Fig. 273

**NOTE:**

**THE VACUUM HOSE MUST BE INSTALLED ALWAYS FALLING FROM INTAKE MANIFOLD PRESSURE SENSOR TO THROTTLE VALVE HOUSING.**

# Ignition Distributor — Remove and Install (14 NV, C 16 NZ)

## REMOVE, DISCONNECT

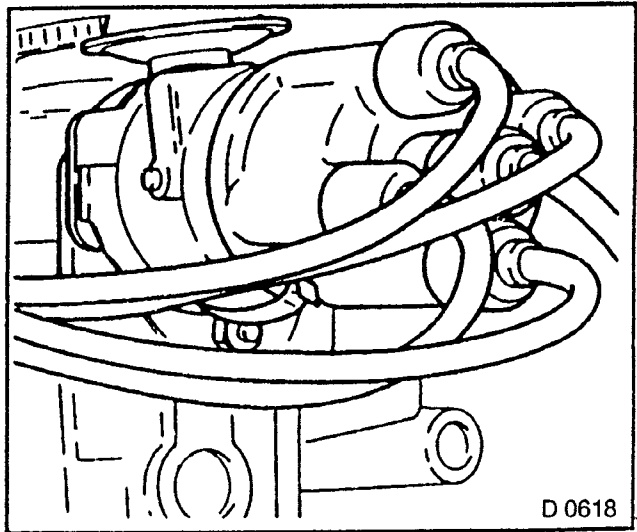
1. Mark position.
2. Wiring harness plug.
3. Hose from vacuum unit (if present).
4. Distributor cap.
5. Ignition distributor.

## INSTALL, CONNECT

1. Ignition distributor on marking.
2. Distributor cap.
3. Hose on vacuum unit (if present).
4. Wiring harness plug.

## INSPECT

1. Adjust ignition.



D 0618

Fig. 274

# Ignition Basic Adjustment (14 NV)

## CHECKING CONDITIONS:

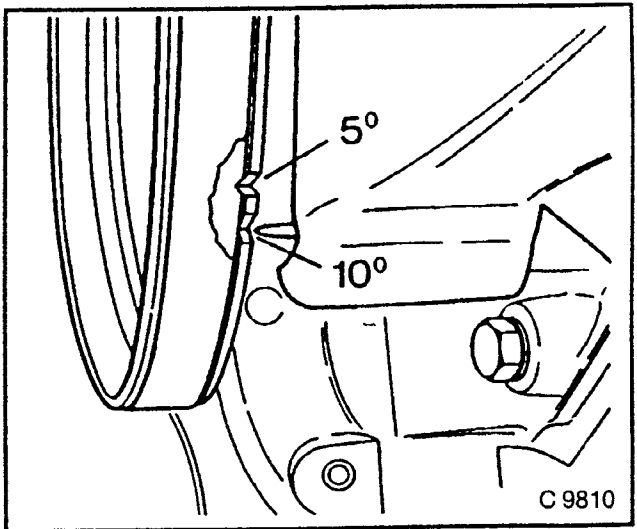
Oil temperature  $\geq 80^{\circ}\text{C}/176^{\circ}\text{F}$

## ENGINE OFF

Vacuum hose removed from vacuum unit  
Opel Tester connected.

## START ENGINE

Speed between 700 rpm and 1000 rpm.



C 9810

Fig. 275

## INSPECT

1. Firing angle — nominal value:  $5^{\circ}$  BTDC.  
If necessary correct ignition basic adjustment by turning distributor.
2. Install vacuum hose on vacuum unit.

## NOTE:

**AFTER BASIC IGNITION  
ADJUSTMENT — CHECK IDLE  
SPEED AND CO CONTENT IN  
EXHAUST AND IF NECESSARY  
ADJUST.**



## High Voltage Distributor — Remove and Install (18 SE/20 SEH)

### REMOVE, DISCONNECT

High voltage distributor cap — MKM-604-A.

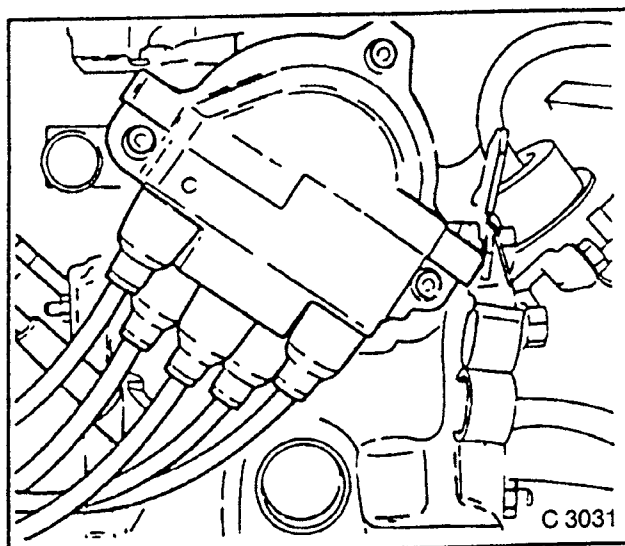


Fig. 276

### REMOVE, DISCONNECT

1. Dust cover.
2. High voltage distributor rotor.

### INSTALL, CONNECT

1. High voltage distributor rotor.
2. Dust cover.
3. High voltage distributor cap.
4. Insert bolts with Locking Compound.

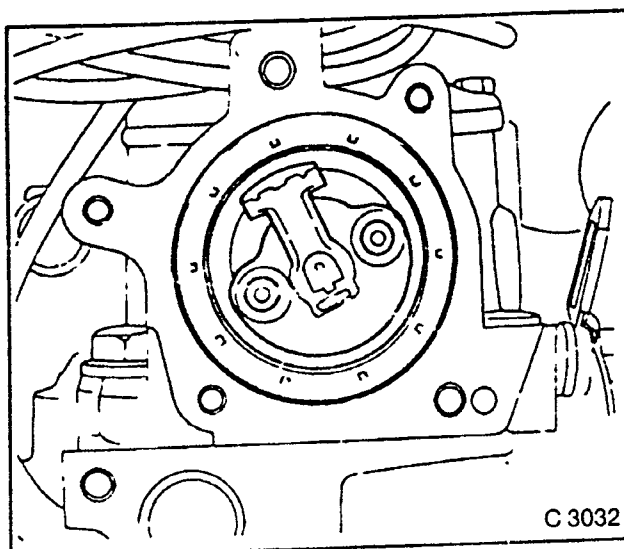


Fig. 277

## Ignition Coil — Remove and Install (14 NV, 18 SE/20 SEH)

### REMOVE, DISCONNECT

1. Wiring harness plug.
2. Ignition coil.

### INSTALL, CONNECT

1. Ignition coil.
2. Wiring harness plug.

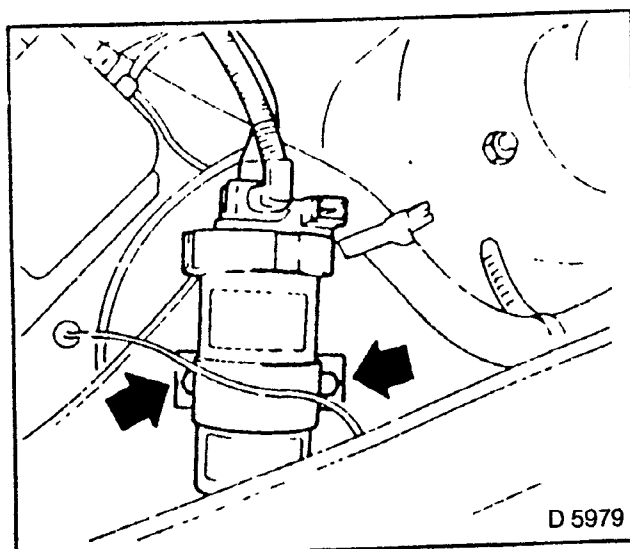


Fig. 278

# Ignition Coil — Remove and Install (C 16 NZ)

## REMOVE, DISCONNECT

- 1. Wiring harness plug.
- 2. Ignition coil.

## INSTALL, CONNECT

- 1. Ignition coil.
- 2. Wiring harness plug.

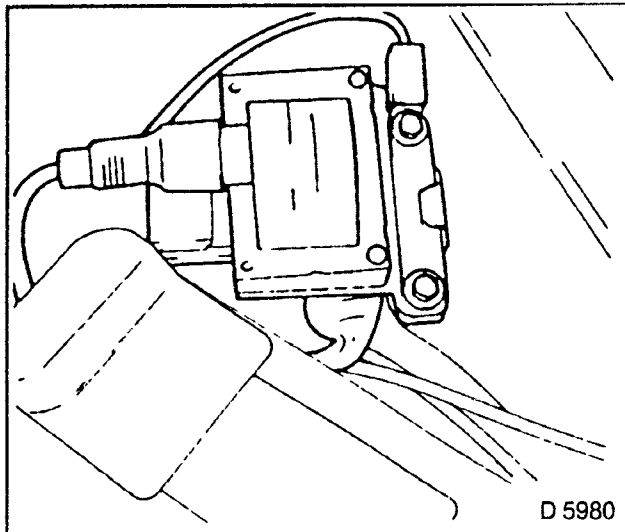


Fig. 279

# Dual Spark Ignition Coil — Remove and Install (C 16 SE)

## REMOVE, DISCONNECT

- 1. Ignition cable.
- 2. Wiring harness plug (1).
- 3. Fastening bolts (2).
- 4. Dual spark ignition coil.

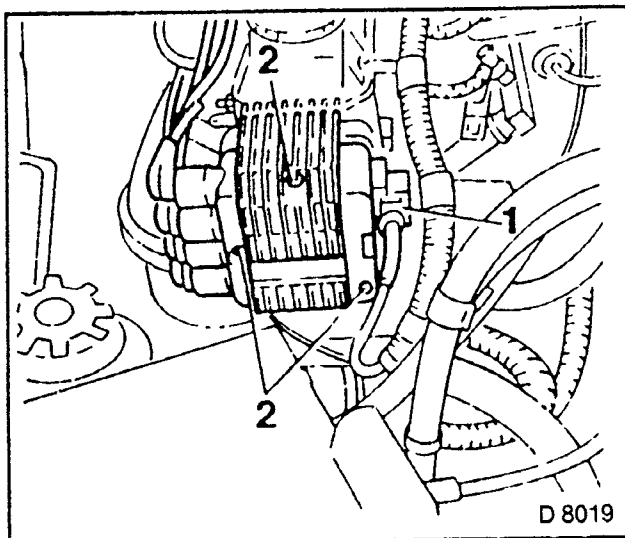


Fig. 280

## INSTALL, CONNECT

- 1. Dual spark ignition coil — tightening torque 8 Nm.
- 2. Wiring harness plug.
- 3. Ignition cable — note firing sequence.

### NOTE:

**CYLINDER NUMBERS ARE ON EDGE OF DUAL SPARK IGNITION COIL HOUSING.**

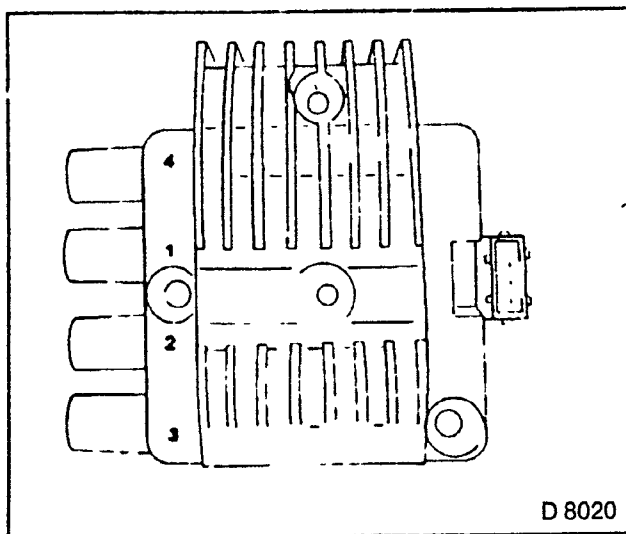
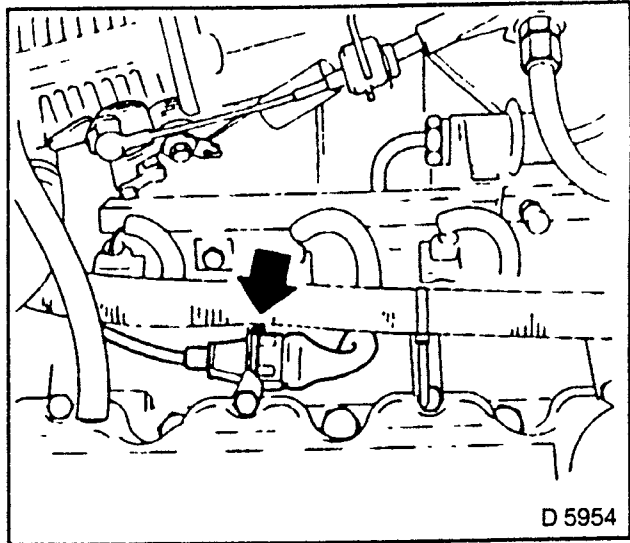


Fig. 281

## Inductive Pulse Pick-up — Remove and Install (C 16 SE)

### REMOVE, DISCONNECT

1. Disconnect wiring harness plug.
2. Detach wiring from wiring harness.



D 5954

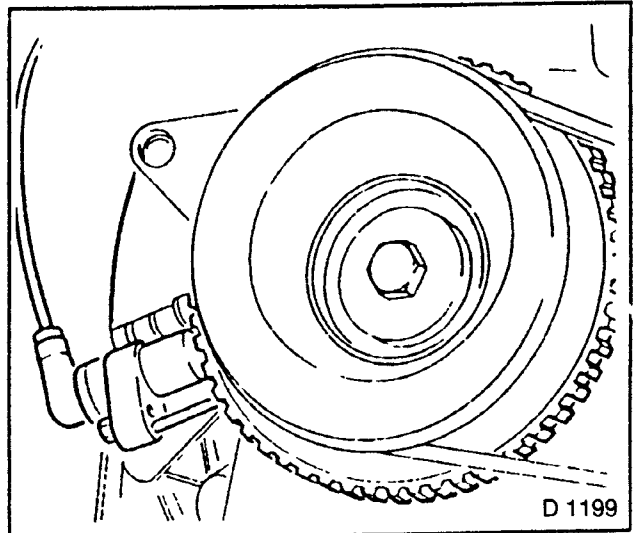
Fig. 282

### REMOVE, DISCONNECT

- 1 Pulse pick-up from bracket.

### INSTALL, CONNECT

1. Pulse pick-up into bracket — note thorough cleanliness.
2. Connect wiring harness plug.
3. Secure wiring to wiring harness.  
Note proper installation of wiring.



D 1199

Fig. 283

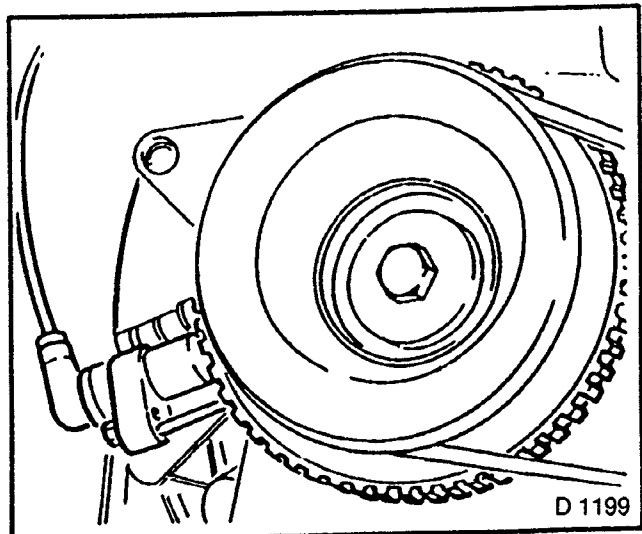
## Gap between Inductive Pulse Pick-up and Increment Disc — Check (C 16 SE)

### MEASURE

Distance between inductive pulse pick-up and increment disc — feeler gauge.

Nominal value:  $1,0 \pm 0,7$  mm.

If gap dimension is incorrect — replace bracket of inductive pulse pick-up.



D 1199

Fig. 284

## Inductive Pulse Pick-up — Remove and Install (18 SE, 20 SEH)

### REMOVE, DISCONNECT

1. Disconnect wiring harness plug — observe cable routing.
2. Inductive pulse pick-up with seal ring.

### INSTALL, CONNECT

1. Inductive pulse pick-up with new seal ring.
2. Connect wiring harness plug — note correct cable routing.

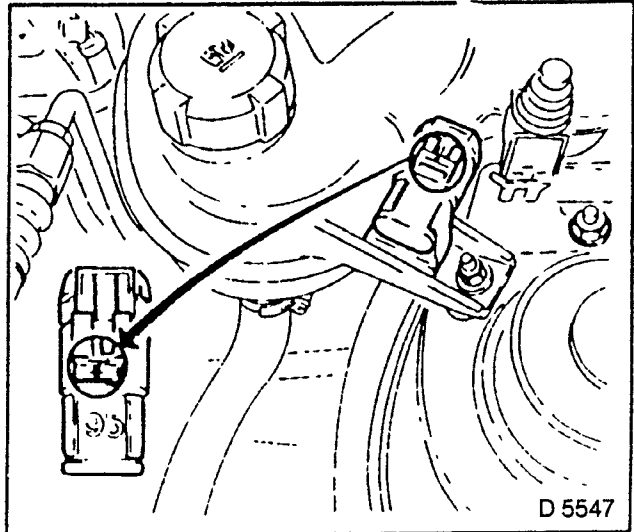
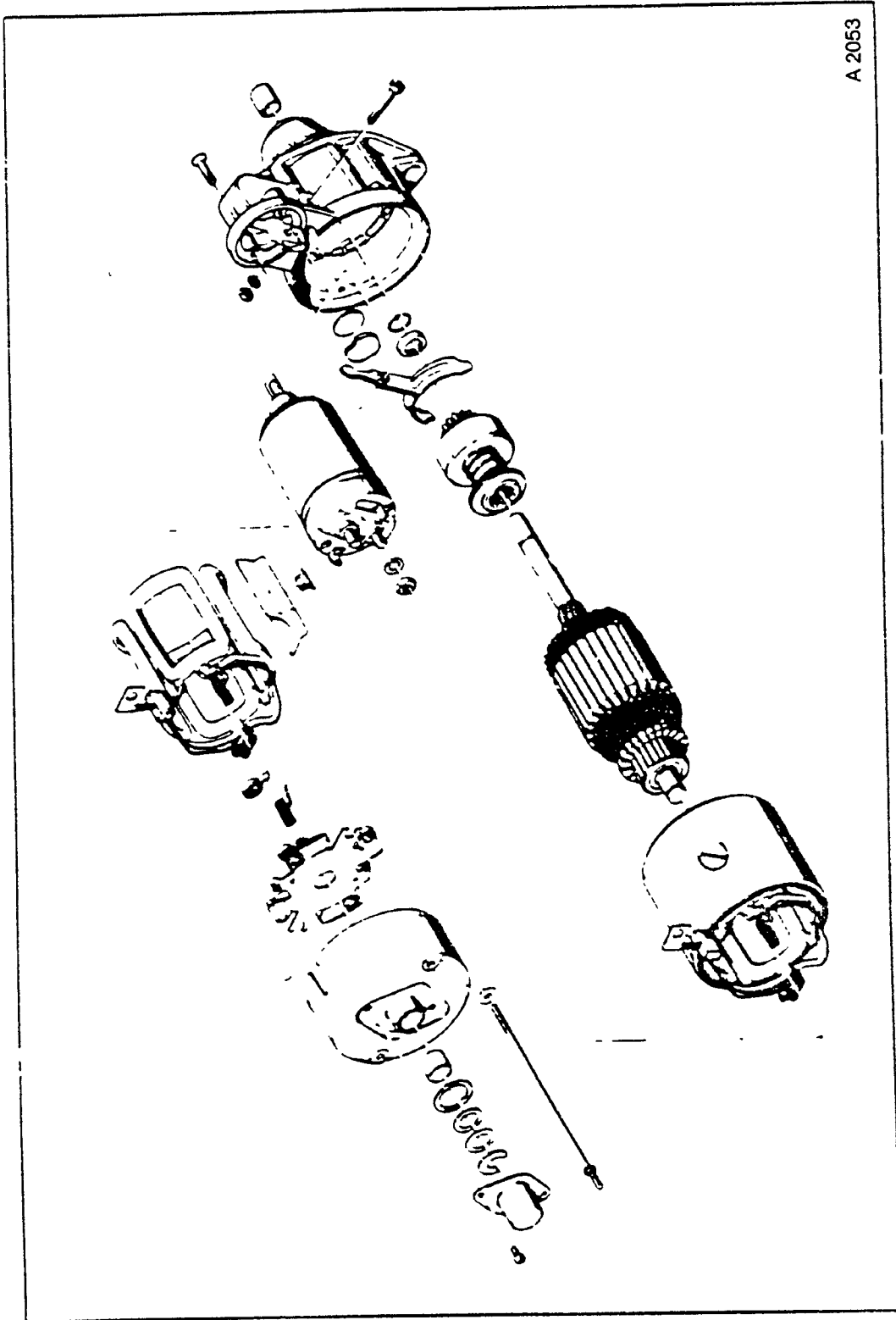


Fig. 285

## Octane Number Plug, Code (all except 14 NV)

1. Remove octane number plug from bracket.
2. Disconnect plug and turn so that arrow on bracket points to adjusted octane number.

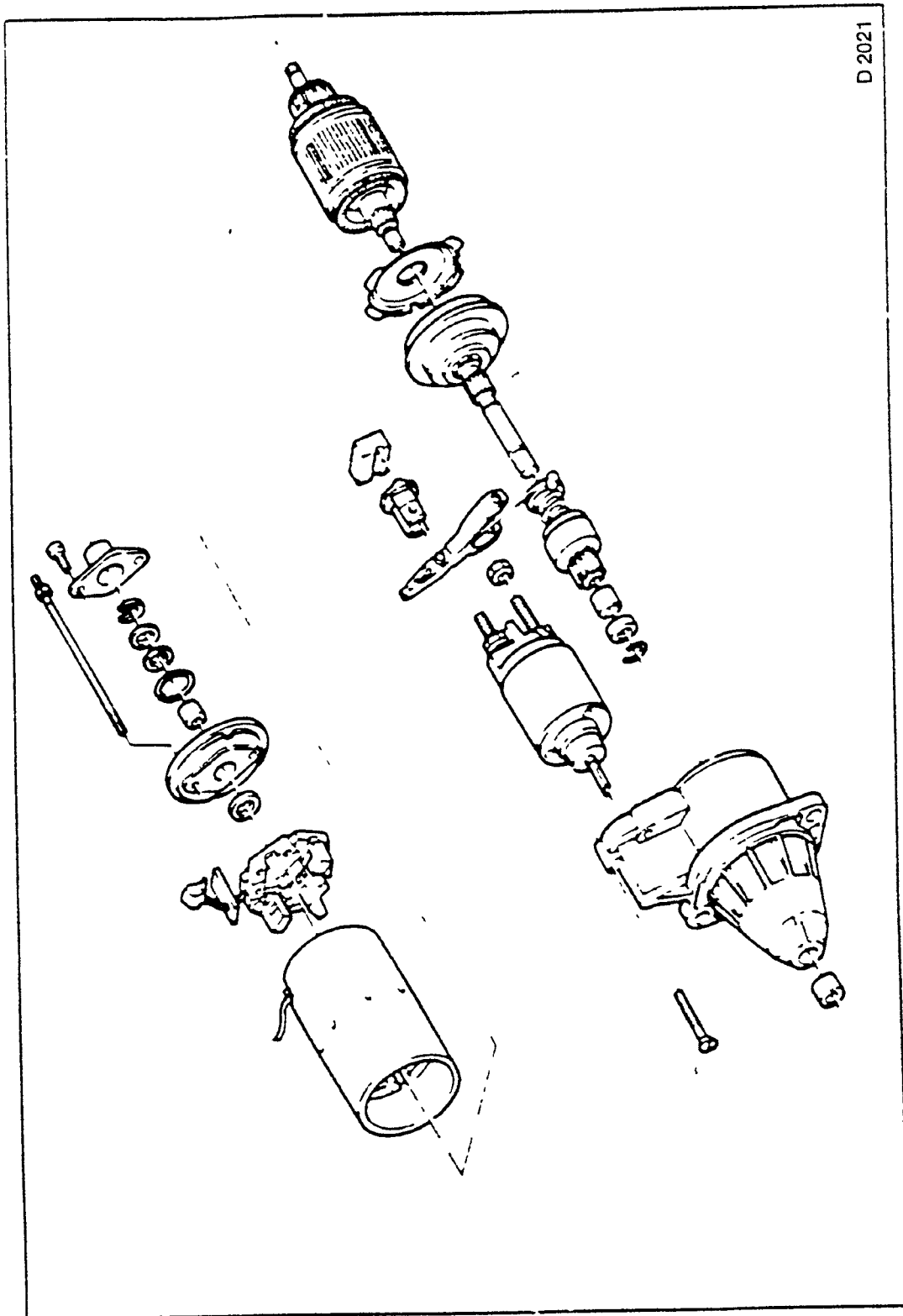
**Bosch Starter**



A 2053

Fig. 286

# Bosch Starter with Reduction Gear



D 2021

Fig. 287

# Starter — Remove and Install

## REMOVE, DISCONNECT

1. Ground lead from battery.
2. Wiring connections from starter.
3. Upper bolt (transmission side with 1,8 and 2,0 ltr. engines).
4. Lower bolt (engine side).
5. Bolt of starter support — if present — from engine block.

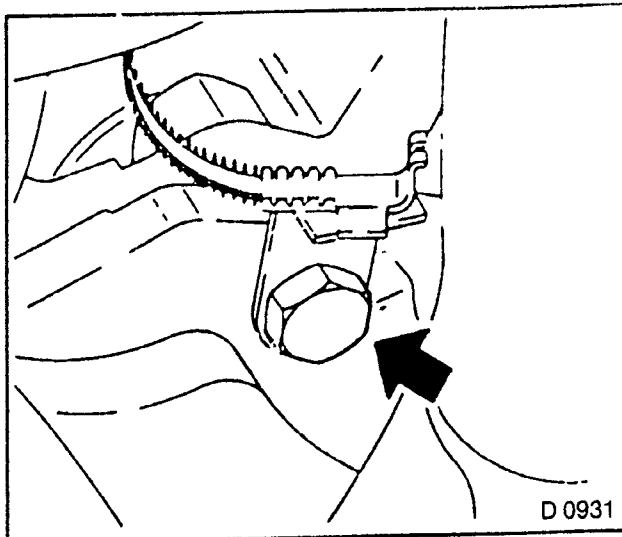


Fig. 288

## TIGHTEN (TORQUE)

| Engine                                 | 1,4/1,6 ltr. | 1,8/2,0 ltr. |
|--|--------------|--------------|
| 1. Starter to cylinder block           |              |              |
| — Engine side                          | 25 Nm        | 45 Nm        |
| 2. — Transmission side                 | —            | 75 Nm        |
| 3. Starter support to cylinder block   | —            | 25 Nm        |
| 4. Connect all wiring, connect battery |              |              |
| 5. Note correct condition and seating  |              |              |

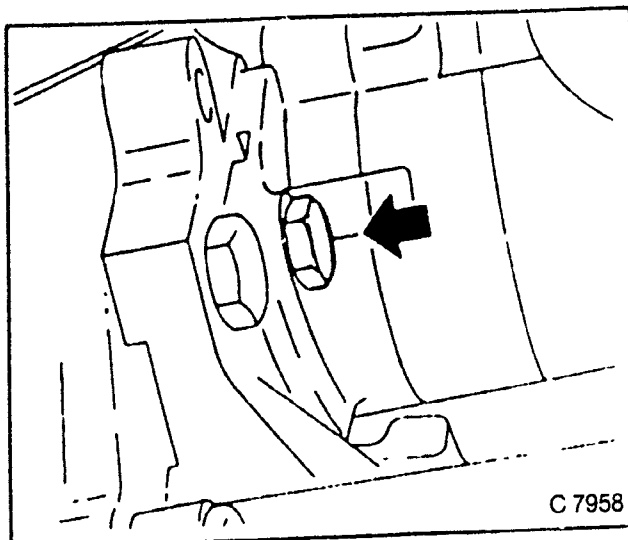


Fig. 289

## Starter — Check (installed)

### INSPECT

#### 1. BATTERY

Properly charged and connection terminals in good condition (positive and negative).

#### 2. STARTER CABLE

Perfect connection to starter and to battery positive terminal, maximum permissible voltage loss in cable should not be greater than 0,5 volts when starting — measure voltage at starter terminal "50" if voltage loss is larger.

Check contact part of ignition lock, selector lever switch, plug connections for adequate contact.

#### 3. STARTER

Connect Opel Tester — note operating instructions.

Red connection clamp to positive terminal of battery.

Black connection clamp to negative terminal of battery.

Clamp — on probe to connecting lead between battery and starter — arrow on clamp — on probe must point away from battery. Put into direct gear, apply service and parking brakes and actuate starter (starter does not turn engine and blocks).

### NOTE:

**MAXIMUM LENGTH OF CHECK: FIVE SECONDS.**

### MEASURE

Voltage approximately 8V

Current consumption approximately 410A

Voltage too low — localize voltage drop

Current consumption too high — short circuit in starter

Current consumption too low — collector dirty  
— carbon brushes worn  
— ignition switch contact defective  
— interruption

When current consumption is too high or too low — overhaul starter.

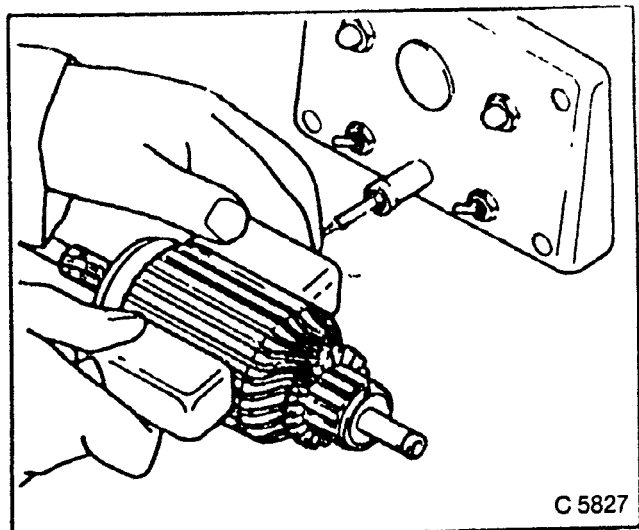
## Starter — Check (Removed and Disassembled) (Bosch)

### CLEAN

1. Rotor windings.
2. Cleaning petrol (normal commercial) — only short contact permissible.

### INSPECT

1. Rotor winding — for short — circuited turn with suitable tester.
2. Short-circuited turn — replace rotor.



C 5827

Fig. 290



**INSPECT**

1. Rotor winding — for short-circuit to ground.
2. Hold probes to armature core and corresponding collector lamination, test lamp must not illuminate.
3. Short-circuit to ground — replace rotor.

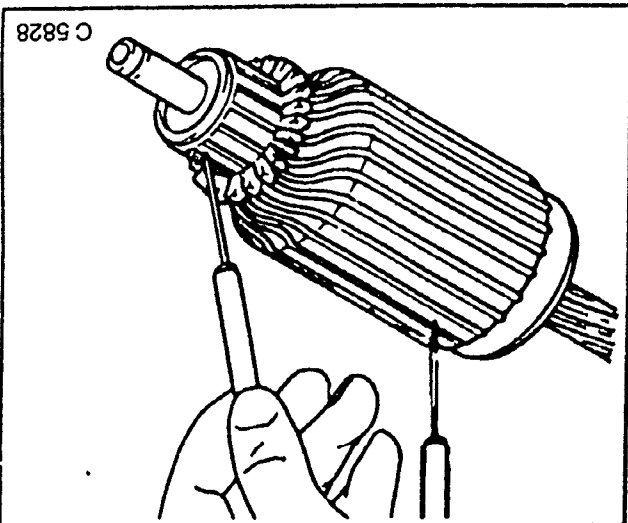


Fig. 291

**INSPECT**

1. Rotor winding — for interruption.
2. Set windings in circuit with ammeter.
3. Scan collector from lamination to lamination quickly.
- Test voltage: 2 volts.
- Voltage variations indicate interruptions.
4. Interruption — replace rotor.

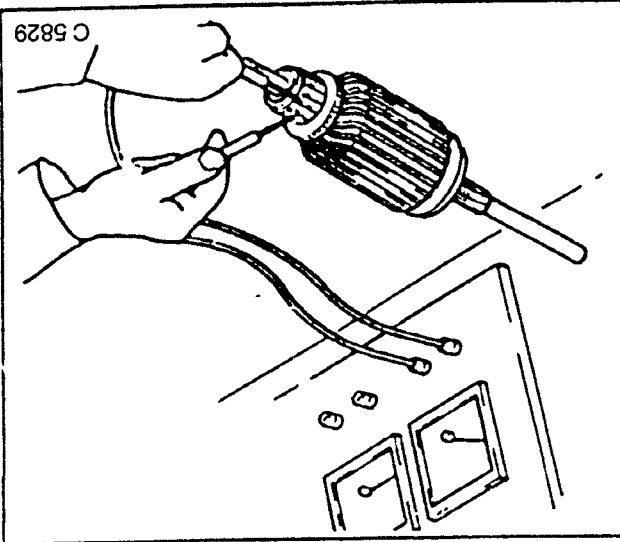


Fig. 292

**INSPECT**

1. Field winding (except stator with permanent magnets)
2. Replace burned or charred windings.
3. Field winding — for short-circuit to ground.
4. Hold probed to ends of windings and stator, test lamp must not illuminate.
5. Short-circuit to ground — replace field winding.

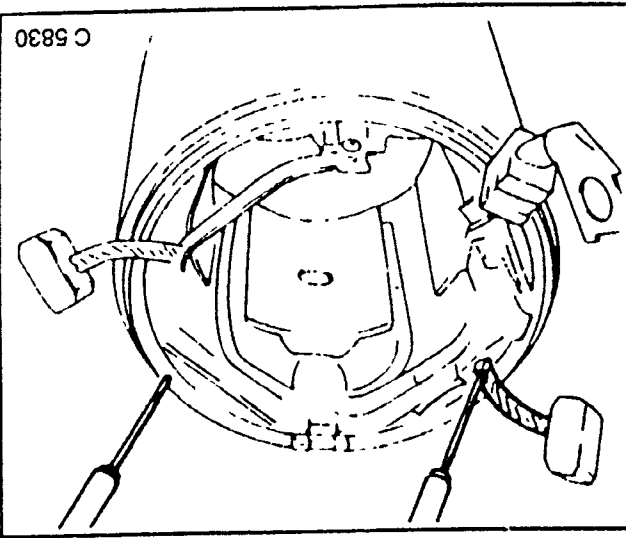


Fig. 293

C 5830

C 5829

C 5828

**INSPECT**

1. Positive brush holder — for short-circuit to ground.
2. Hold probes on negative brush holder and positive brush holder, test lamp must not illuminate.
3. Short-circuit to ground of brush holder — replace brush holder plate.

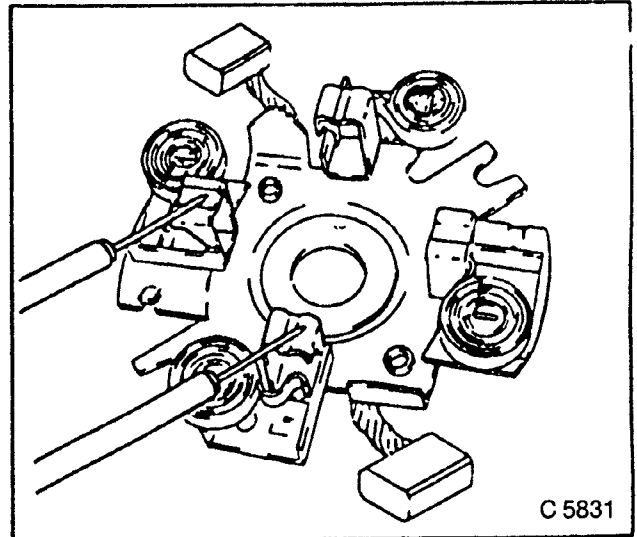


Fig. 294

**Field Winding — Replace**

(Except stator with permanent magnets)

**STARTER REMOVED AND DISASSEMBLED****REMOVE, DISCONNECT**

1. Field winding.
2. Mark installation position of pole piece in housing.
3. Loosen four pole piece screws.

**INSTALL, CONNECT**

1. Field winding.
2. Note correct order of rubber grommet (1).
3. Align pole piece parallel to housing and tighten.

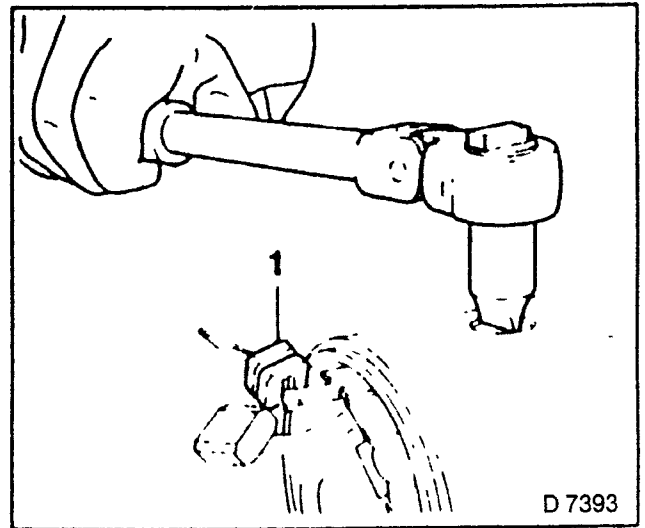


Fig. 295

**Carbon Brushes —  
Replace (Bosch Starter)****STARTER REMOVED AND DISASSEMBLED**

Recommended if length falls below 13 mm (Bosch starter).

**REMOVE, DISCONNECT**

1. Unsolder carbon brushes from brush holder plate.

**INSTALL, CONNECT**

1. Solder carbon brushes.
2. Hold flex with flat nose pliers, to prevent solder from running up flex.

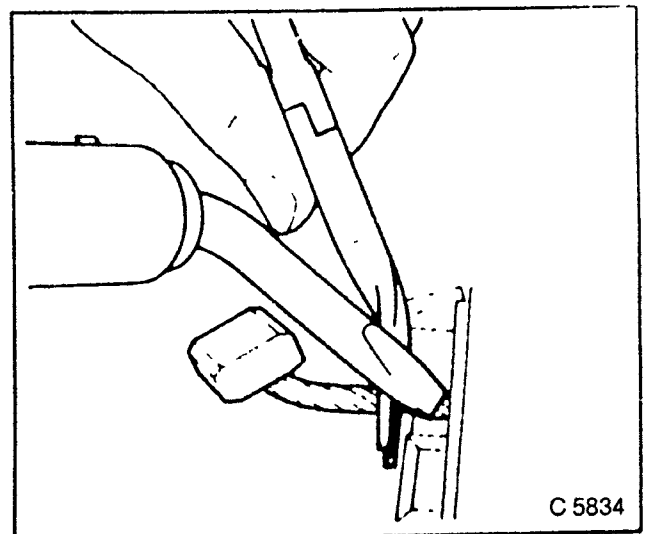


Fig. 296

## Bearing Bushings — Replace (Bosch Starter)

STARTER REMOVED AND DISASSEMBLED

### NOTE:

1. Soak bearing bushings before installation at least 1/2 hour in oil.

### REMOVE, DISCONNECT

1. Press bushing out of drive bearing — suitable drift

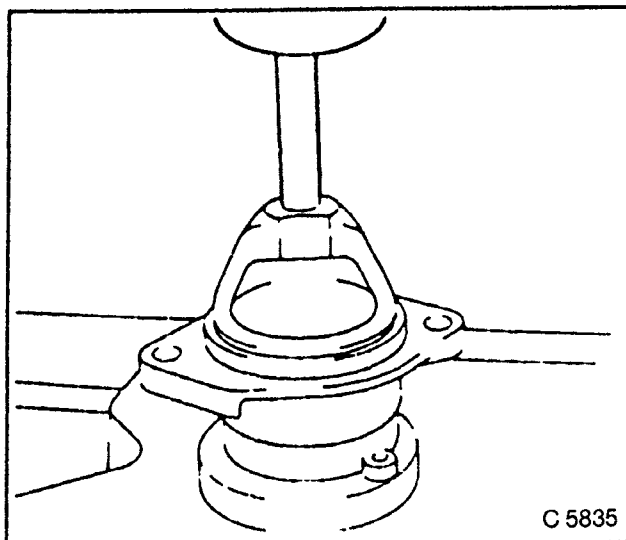


Fig. 297

### INSTALL, CONNECT

1. Press bushing (1) flush into drive bearing — KM-266-A.

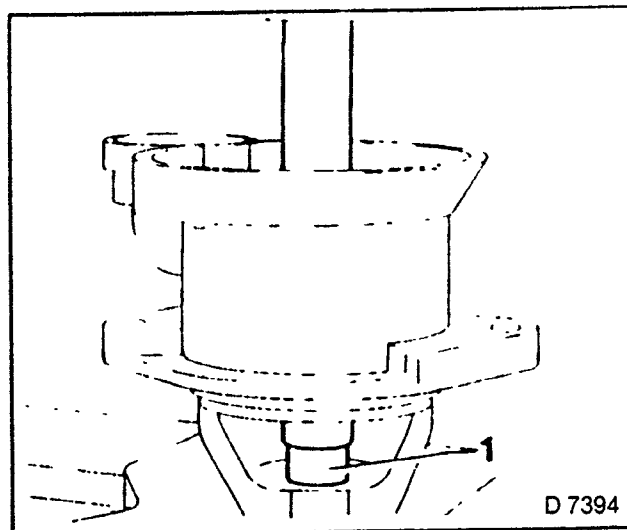


Fig. 298

### REMOVE, DISCONNECT

1. Bushing from collector bearing — Bosch starter.
2. Press off with suitable drift — place pipe piece (1) underneath.

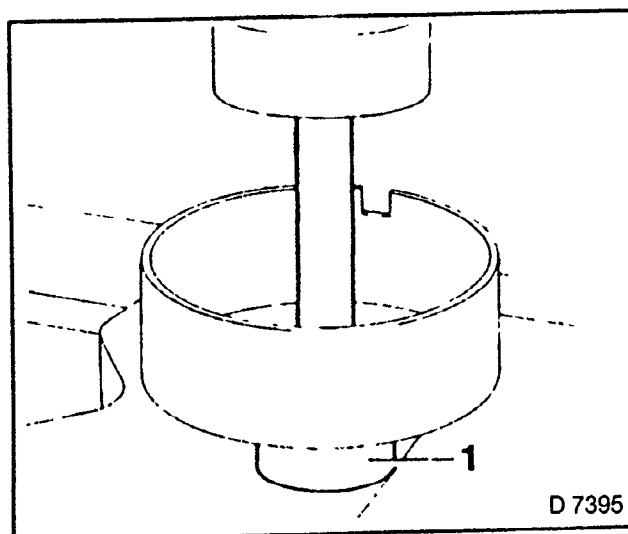


Fig. 299

**INSTALL, CONNECT**

1. Press bushing into collector bearing (1)  
— KM-266-A.

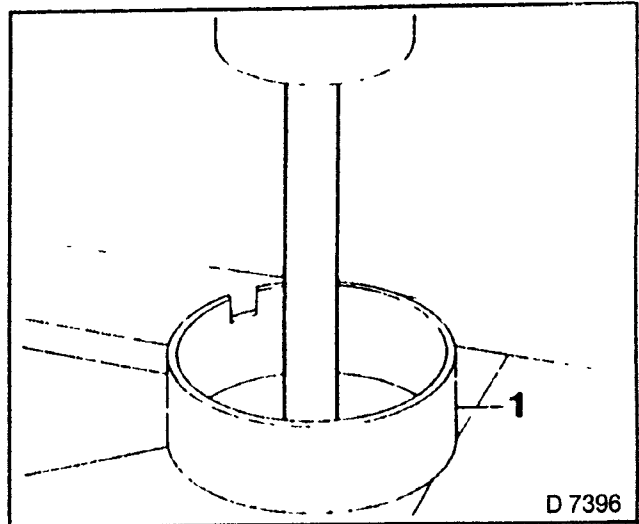


Fig. 300

D 7396

**REMOVE, DISCONNECT**

1. Remove with inner extractor.

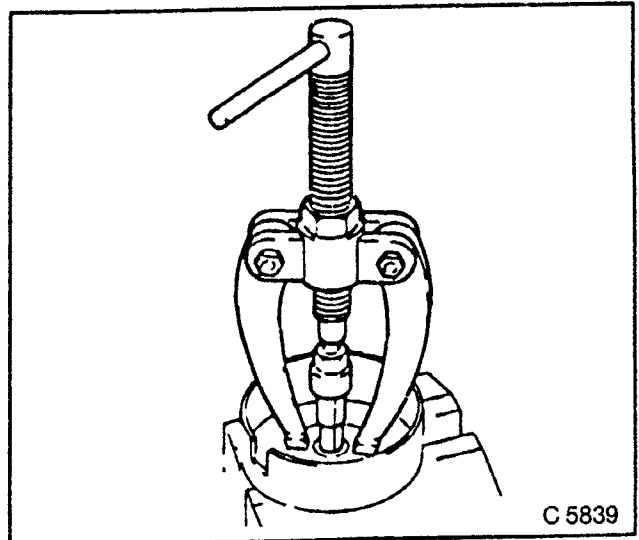


Fig. 301

C 5839

**INSTALL, CONNECT**

1. Press in bushing — suitable drift.

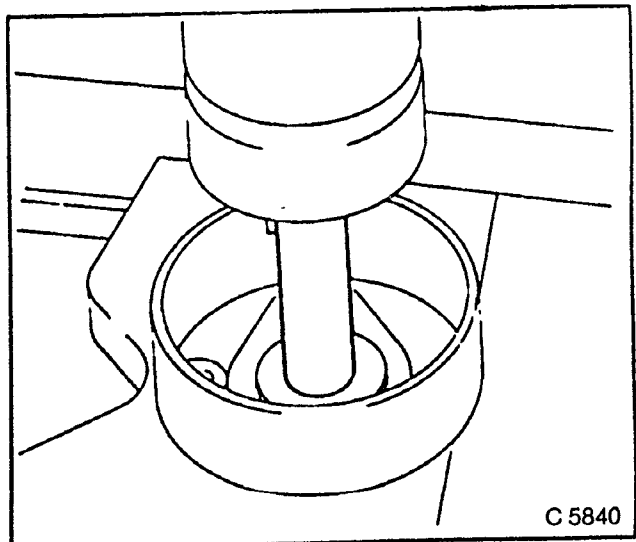


Fig. 302

C 5840

## Bosch Starter — Disassemble and Assemble

### REMOVE, DISCONNECT

1. Support from starter (if present).
2. Bearing cap from collector.
3. Remove armature retaining clip (1) and spacer washer(s) (2) from armature shaft.
4. Note rubber seal (3).

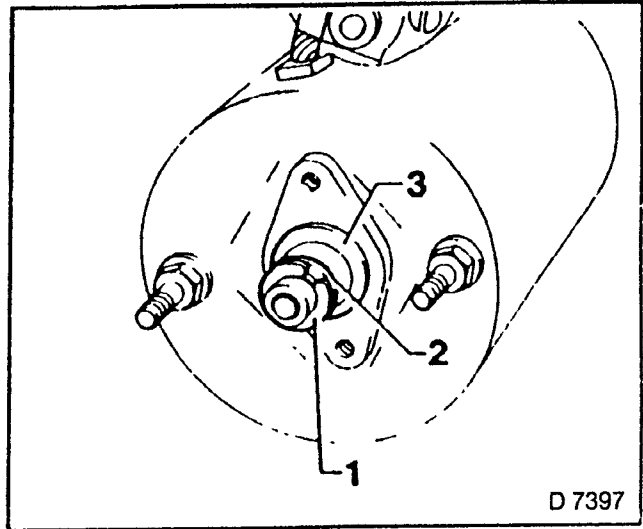


Fig. 303

### REMOVE, DISCONNECT

1. Collector bearing.
2. Stator mounting screws (1).

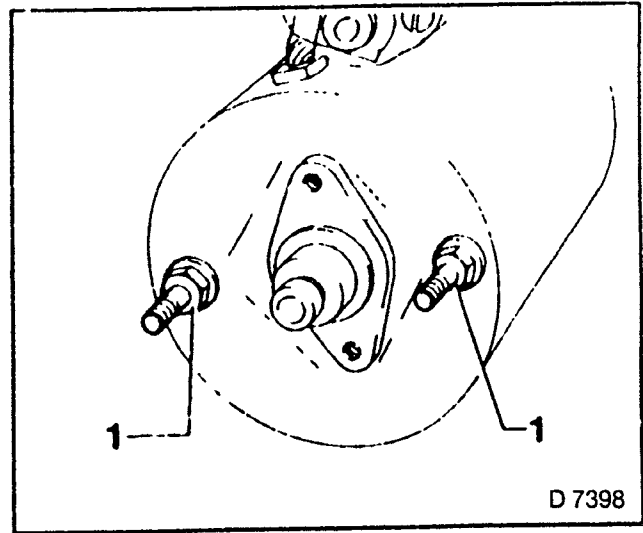


Fig. 304

### REMOVE, DISCONNECT

1. Remove brush holder plate from rotor.
2. Remove positive carbon brushes (arrows) from brush holder using suitable remover hooks (bent electrode wire).

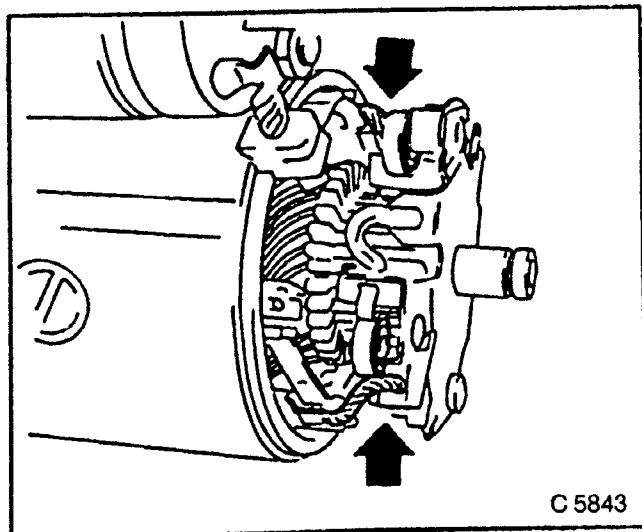


Fig. 305

**REMOVE, DISCONNECT**

- 1. Field windings connection — from solenoid switch.

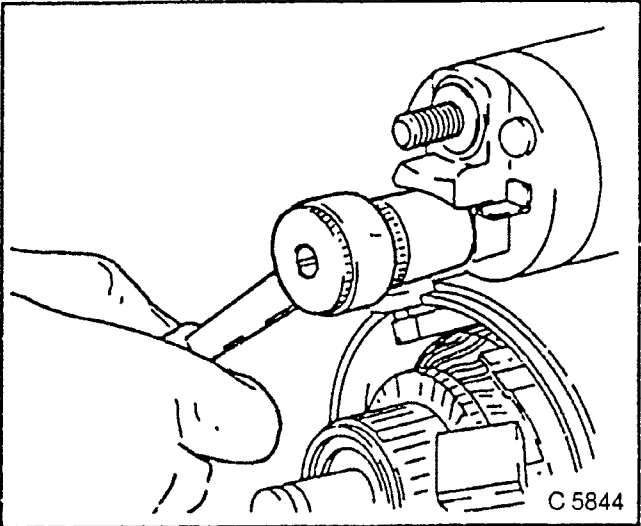


Fig 306

**REMOVE, DISCONNECT**

- 1. Solenoid switch.
- 2. Unscrew from drive bearing.
- 3. Pull back and detach.

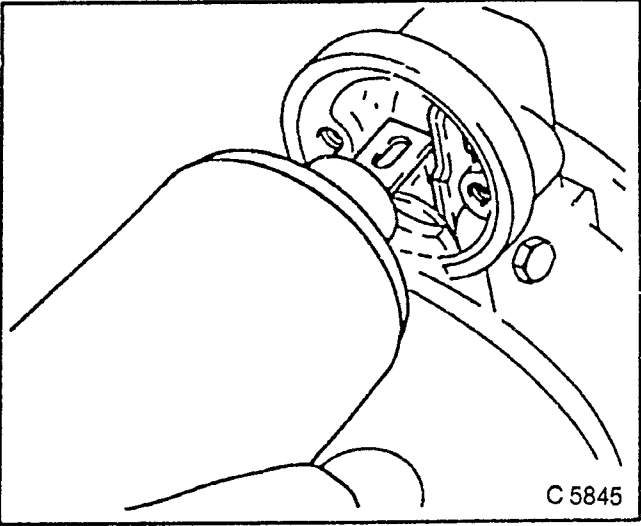


Fig. 307

**REMOVE, DISCONNECT**

- 1. Stator.
- 2. Axle for engaging lever — unscrew nut (1).
- 3. Sealing plate (2).

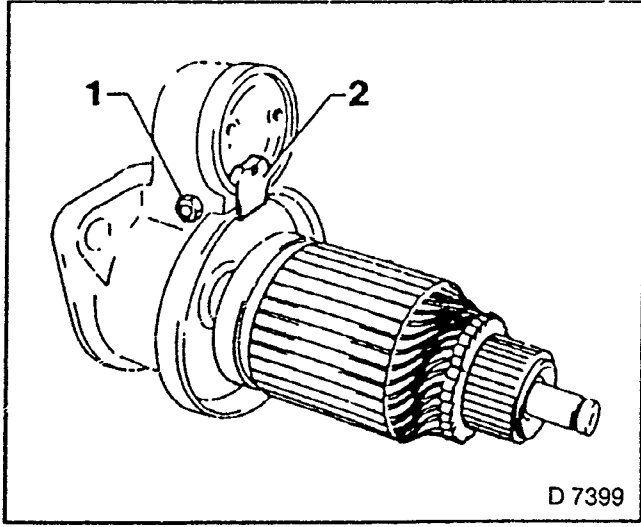


Fig. 308

**REMOVE, DISCONNECT**

1. Remove rotor with engaging lever (1) from drive bearing.
2. Remove engaging lever.

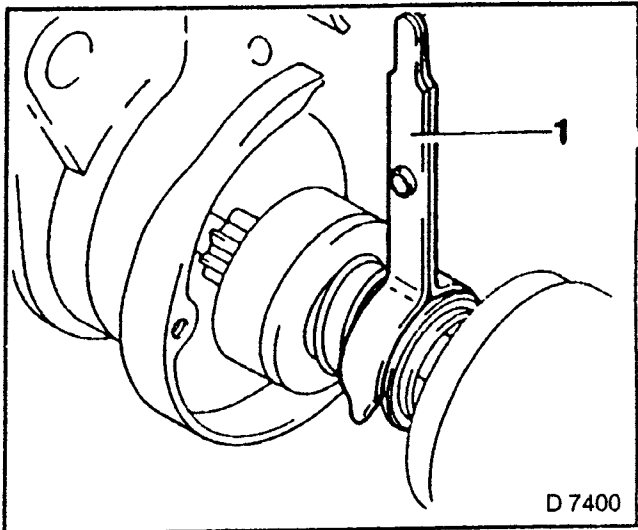


Fig. 309

**REMOVE, DISCONNECT**

1. Retaining ring (1).
2. Knock back onto armature shaft.

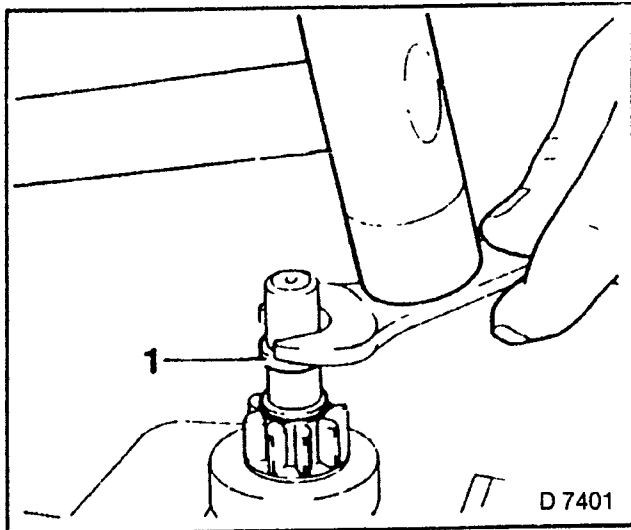


Fig. 310

**REMOVE, DISCONNECT**

1. Remove snap ring (1) — pliers (commercially available).
2. Remove retaining ring (2) and washer (3).

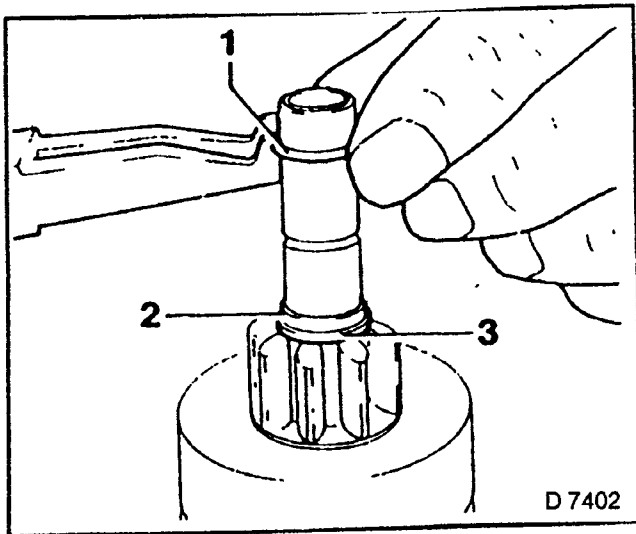


Fig. 311

**REMOVE, DISCONNECT**

1. Free wheel with pinion.

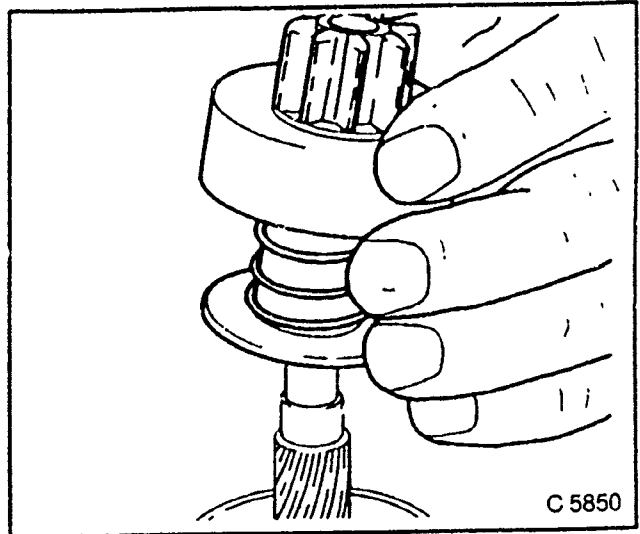


Fig. 312

**INSTALL, CONNECT**

1. Lubricate sliding parts — Grease.
2. Free wheel with pinion
  - washer
  - new snap ring
  - press retaining ring over snap ring with two wrenches.
3. Rotor with engaging lever — install into drive bearing.
4. Sealing plate — Install with metal side to drive bearing.
5. Collector bearing.
6. Note alignment of bores in brush holder.
7. Check starter.

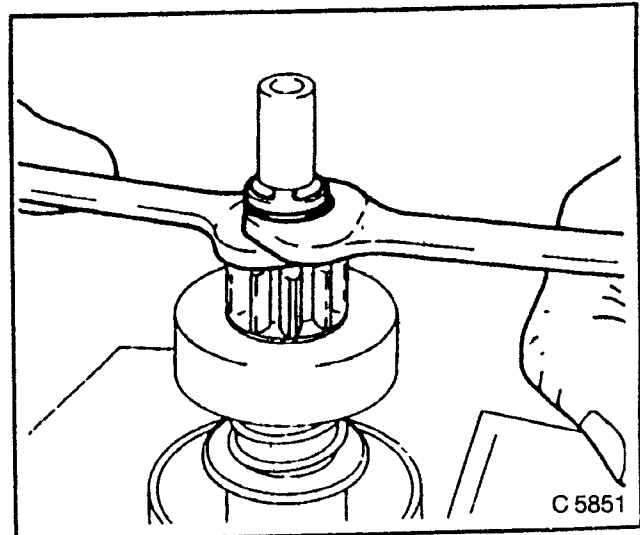


Fig. 313

**Bosch Reduction Gear Starter — Disassemble and Assemble****REMOVE, DISCONNECT**

1. Unscrew field winding connection (2).
2. Solenoid switch — loosen (1) and detach.

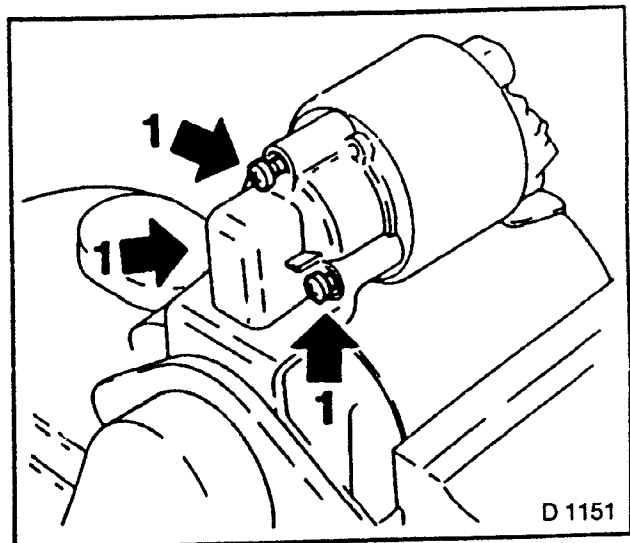


Fig. 314



**REMOVE, DISCONNECT**

1. Stator mounting screws (3).

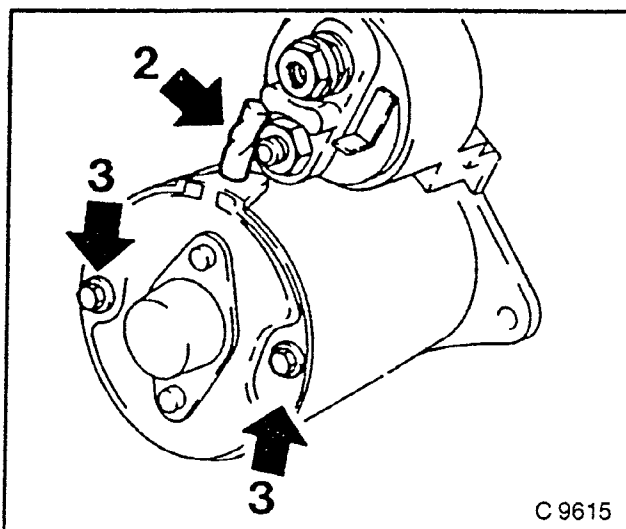


Fig. 315

**REMOVE, DISCONNECT**

1. Drive bearing.
2. Lever out sealing plate.
3. Pull out engaging lever bearing from guide.

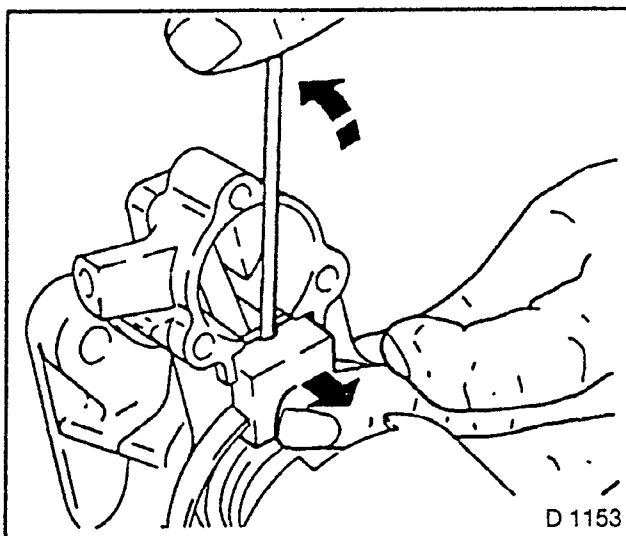


Fig 316

**REMOVE, DISCONNECT**

1. Pull out reduction gear from stator.
2. Metal cap.

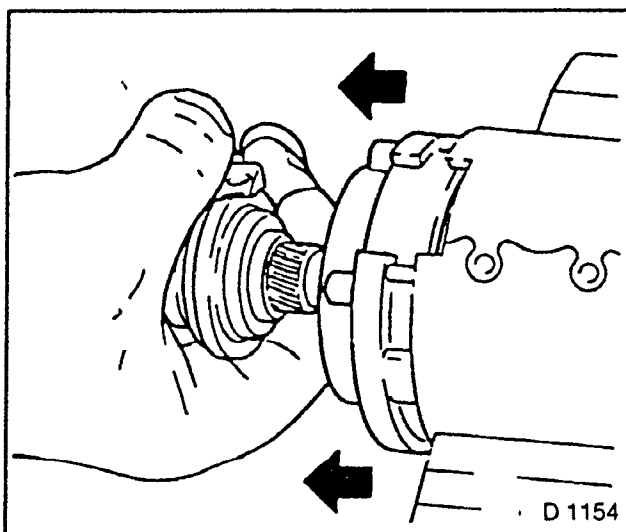


Fig. 317

**REMOVE, DISCONNECT**

1. Rotor from stator — with collector bearing.
2. Remove metal cap.

**WARNING:**  
DO NOT DAMAGE PERMANENT  
MAGNETS.

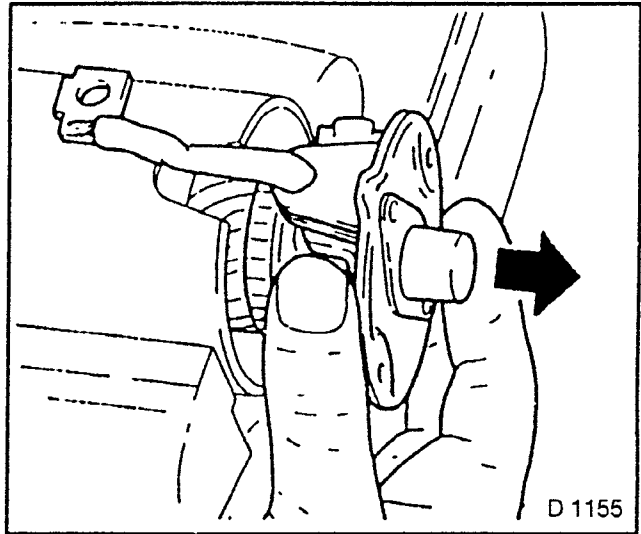


Fig. 318

**REMOVE, DISCONNECT**

1. Protective cap from collector bearing.

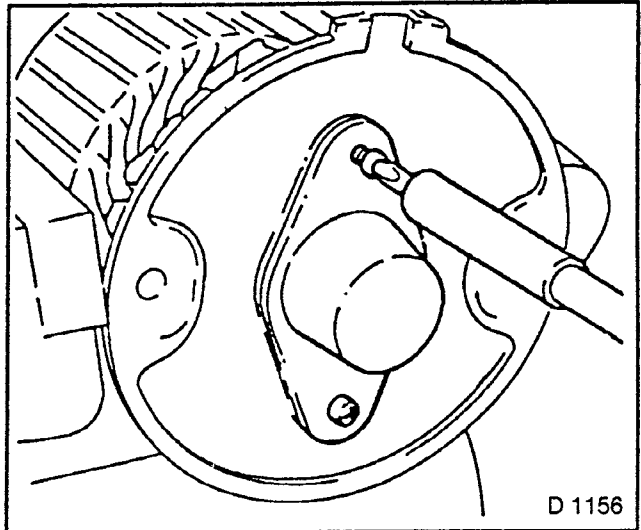


Fig. 319

**REMOVE, DISCONNECT**

1. Collector bearing.
2. Remove lock washer.
3. Washer.
4. Seal rings.

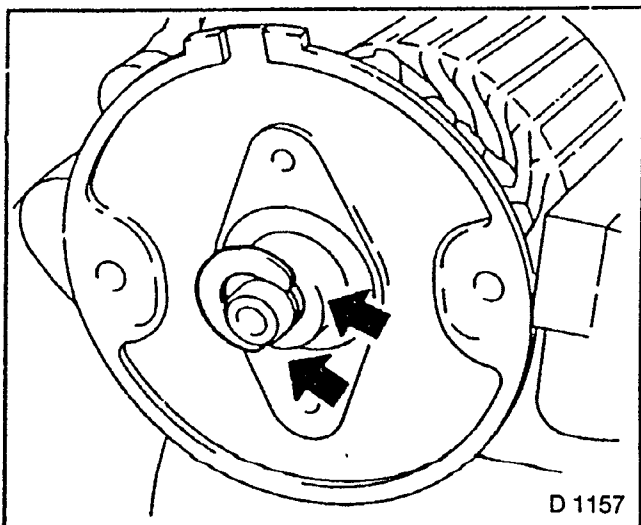


Fig. 320

**REMOVE, DISCONNECT**

1. Brush holder plate.  
When re-using:  
push carbon brushes onto suitable piece  
of pipe (1) or shaft, to prevent contact  
springs from springing out.

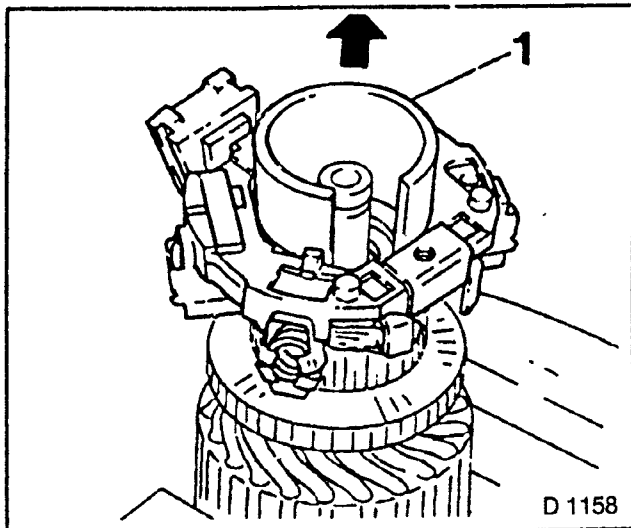


Fig. 321

**REMOVE, DISCONNECT**

1. Reduction ring gear (plastic).
2. Disconnect retaining ring and snap ring  
— see operation “Bosch Starter,  
Disassemble and Assemble”.
3. Remove lock washer (1) and washer (2).

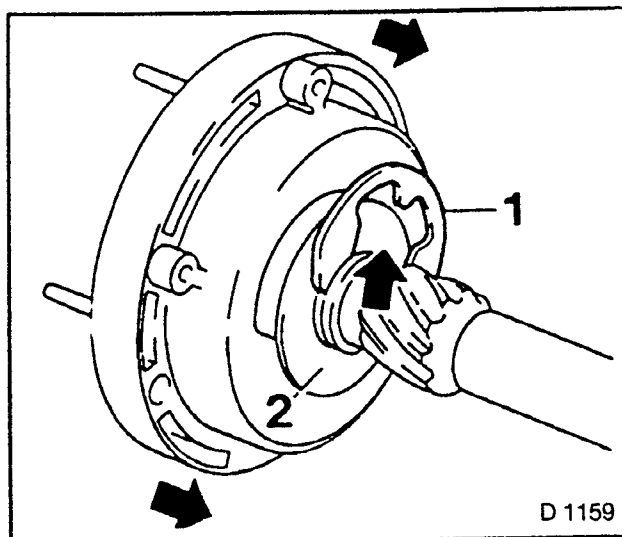


Fig. 322

**REMOVE, DISCONNECT**

1. Knock permanent magnets carefully from  
stator.  
Use soft metal drift.

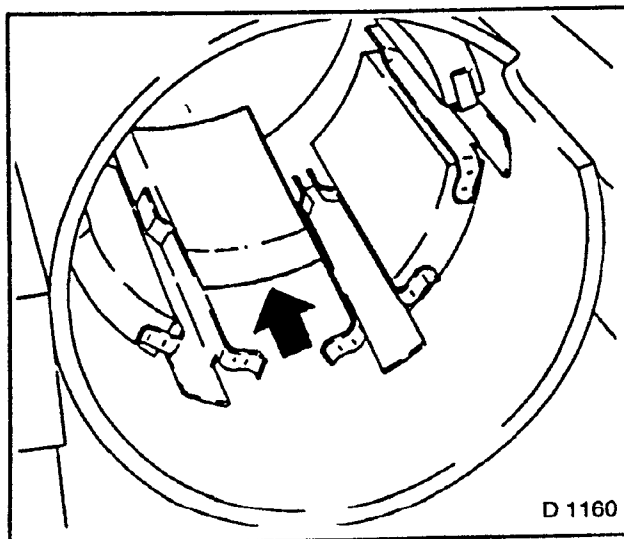


Fig. 323

**INSTALL, CONNECT**

1. Permanent magnets.
2. Reduction ring gear.
3. Rotor.
4. Brush holder plate.
5. Collector bearing.
6. Bearing cap.
7. Insert seal ring (arrow).
8. Solenoid switch.

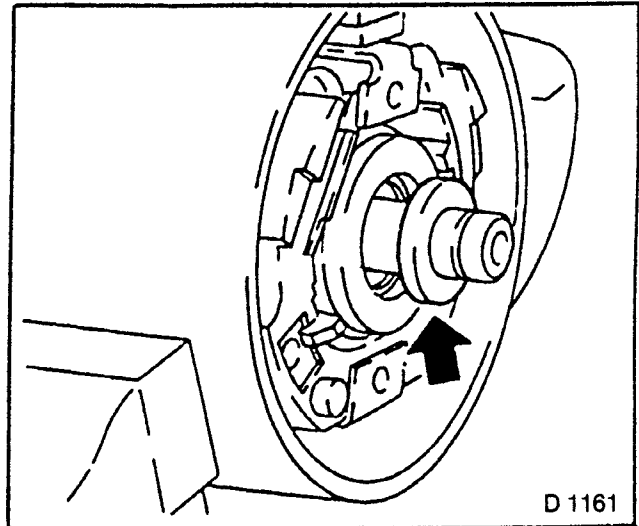


Fig. 324

# Bosch Alternator

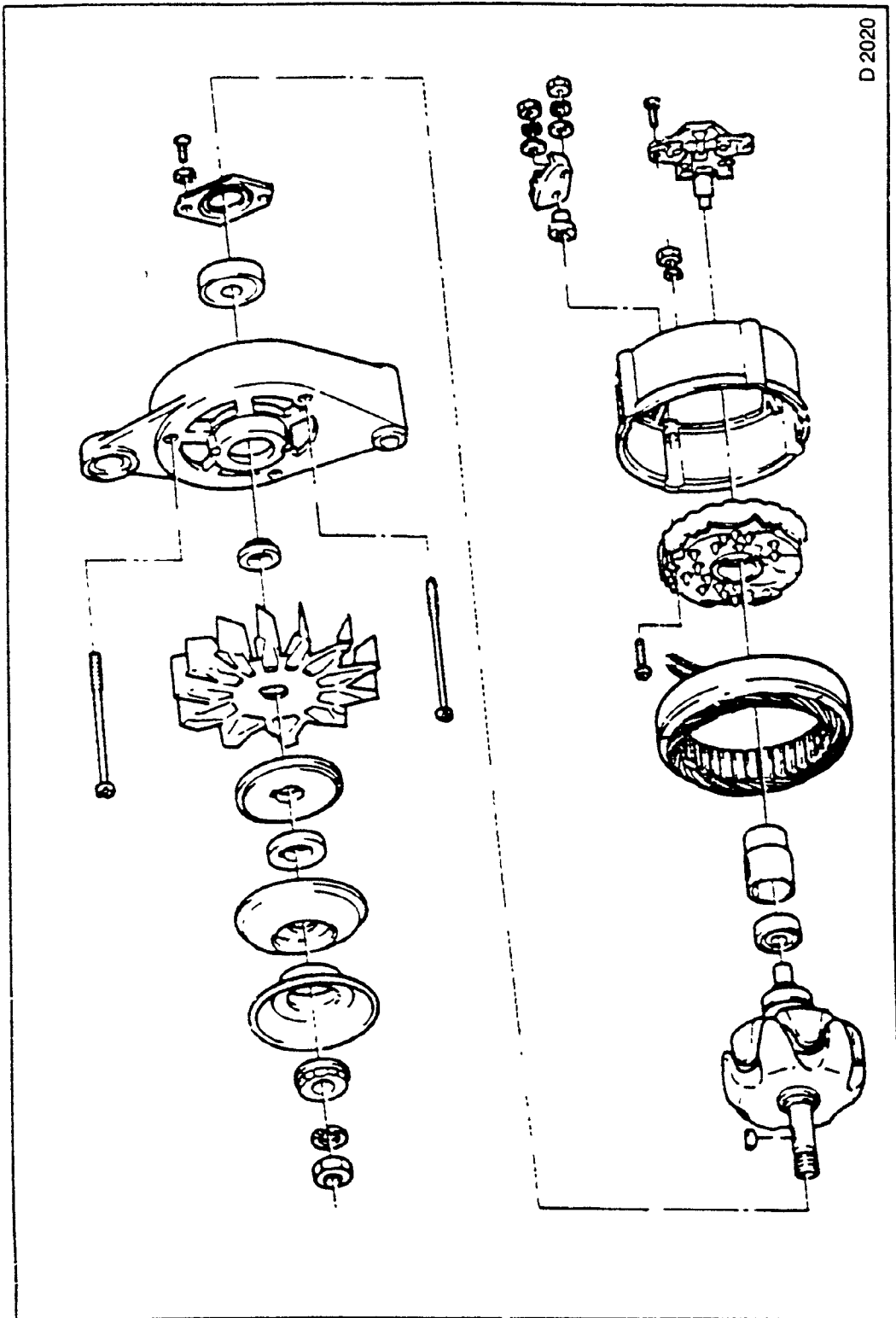


Fig 325

## Alternator — Remove and Install

### REMOVE, DISCONNECT

1. Ground cable from battery.
2. Air intake hose — if present.
3. Cable connections from alternator.
4. Drive belt.
5. Alternator from retaining strap and lower fastening.

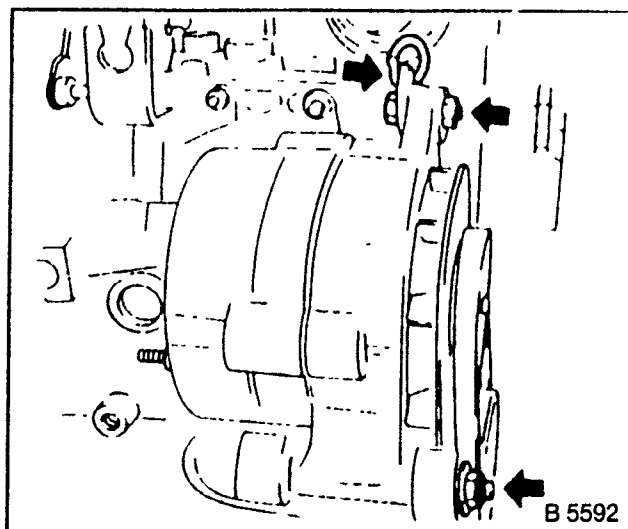


Fig. 326

### INSTALL, CONNECT

1. Alternator (tighten by hand).
2. Install and tension drive belt.
3. Cable connections to alternator.
4. Ensure perfect condition and seating.
5. Air intake hose — if present.
6. Ground cable to battery.

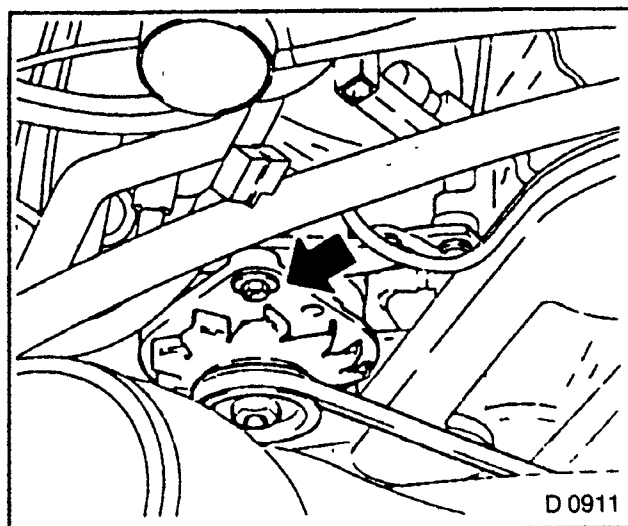


Fig. 327

## Bosch Alternator — Check

The check consists of a performance check and a regulator voltage check, carry out the performance check first! For simultaneous evaluation of electronic components, use appropriate oscilloscope curve.

The check can be carried out in assembled condition as well as on the test stand. The check described here is for alternators in assembled condition, which can be applied analogously to the test stand.

A fully charged battery is required for this check.

### WARNING:

Note the following safety measures:

1. Negative terminal from battery, alternator and regulator must match.
2. Never allow alternator to run on an uncontrolled open circuit.
3. Never short the terminals to alternator and regulator.
4. Do not reverse polarity of alternator.
5. When an additional battery is connected (e.g. as starting aid), it must be noted that the same battery terminals are connected.
6. When charging the battery with a charger, connecting lines of charger must be connected to correct battery terminals. Disconnect ground cable during charging.

**INSPECT**

1. Alternator output.
2. Circuit diagram.
  1. Load resistor, set parallel to battery.
  2. Battery.
  3. Voltmeter.
  4. Ammeter.
  5. Ignition lock.
  6. Charge telltale.
  7. Alternator.
3. Disconnect battery.
4. Disconnect connecting cable from alternator terminal "B +".
5. Set ammeter (measuring range 100A) in disconnected line.
6. Connect battery.
7. Connect controllable load resistor to battery terminals.
8. Before connecting, set resistor at "0"; connect first to battery, then to resistor.
9. Connect tachometer.
10. Connect oscilloscope according to manufacturer's instructions.
11. Connect battery.
12. Start engine and read off resulting current at various engine speeds.

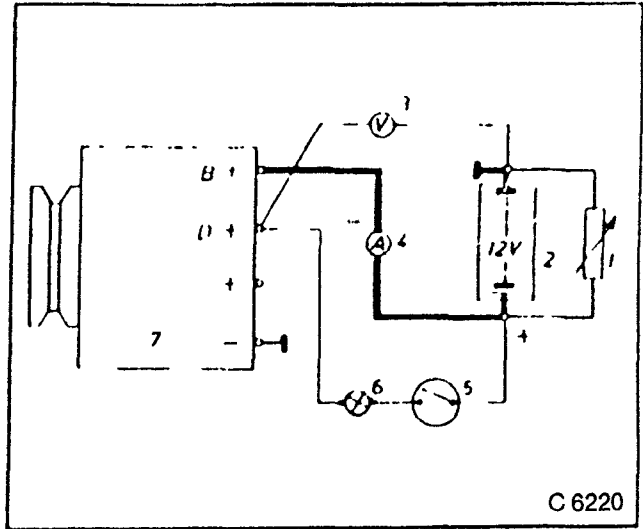


Fig. 328

**INSPECT**

1. Alternator output.
2. Adjust load resistor, if the required load currents are not attained.

The shape of the voltage curves on oscilloscope should be regular.

Test value: 5 to 7A

If the required minimum current intensity is not attained, or if the oscilloscope picture shows variations, the alternator should be overhauled.

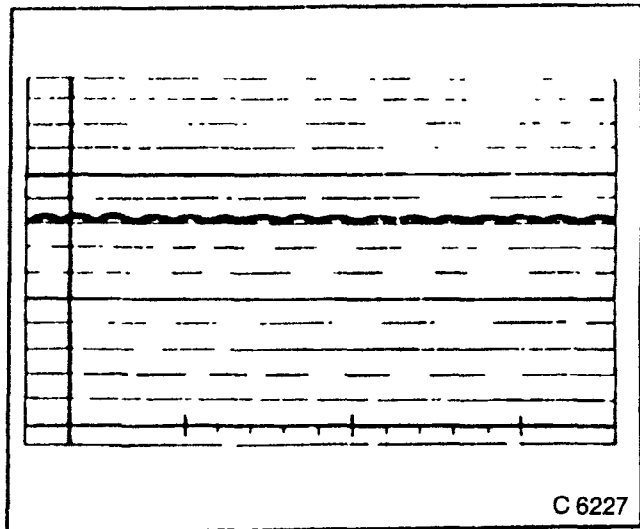


Fig. 329

**INSPECT**

1. Regulated voltage.
2. Circuit diagram.
  1. Battery.
  2. Ignition lock.
  3. Charge telltale.
  4. Resistor, for attainment of load current with the battery set in series.
  5. Voltmeter.
  6. Ammeter.
  7. Alternator.

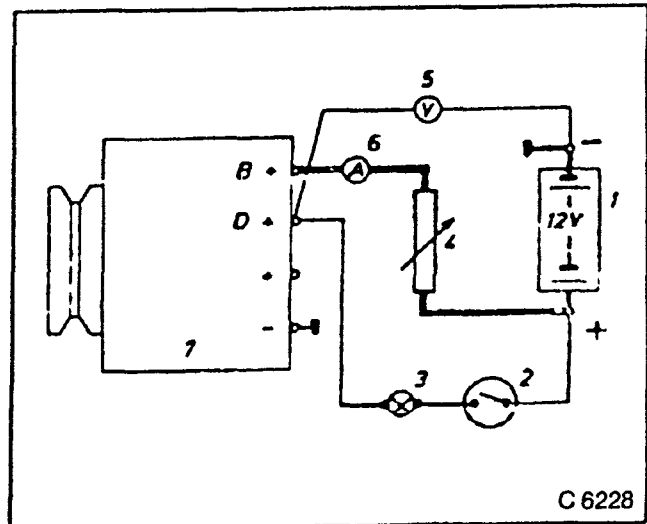


Fig. 330

**INSPECT**

1. Regulated voltage.
2. Bosch alternator:  
Connect tachometer, voltmeter, ammeter and load resistor according to manufacturer's instructions.
3. Disconnect ground cable from battery.
4. Disconnect cable from alternator terminal "B +".
5. Set ammeter (measuring range 100 A) between disconnected cable and alternator terminal "B +".
6. Set resistor in series to battery.
7. Connect ground cable to battery.
8. Start engine.  
Bosch alternator:
9. Adjust load resistor, until ammeter shows prescribed value.
10. Read off regulated voltage — for test values see Technical Data page 312.

**WARNING:**

**ONLY CHECK ALTERNATOR WITH PARALLEL SWITCHING, FULLY CHARGED BATTERY, SWITCH OFF LOAD RESISTOR AND BATTERY AFTER ALTERNATOR STANDSTILL.**

**DISCONNECTING OF LOAD WITHOUT PARALLEL SWITCHING BATTERY LEADS TO VOLTAGE TRANSIENTS, WHICH CAN LEAD TO DAMAGE TO THE ALTERNATOR DIODES.**

## **Bosch Alternator — Disassemble and Assemble**

**REMOVE, DISCONNECT**

1. Pulley nut.
2. Spring ring.
3. Washer.
4. Pulley halves.
5. Spacing ring.
6. Fan wheel.
7. Spring washer.

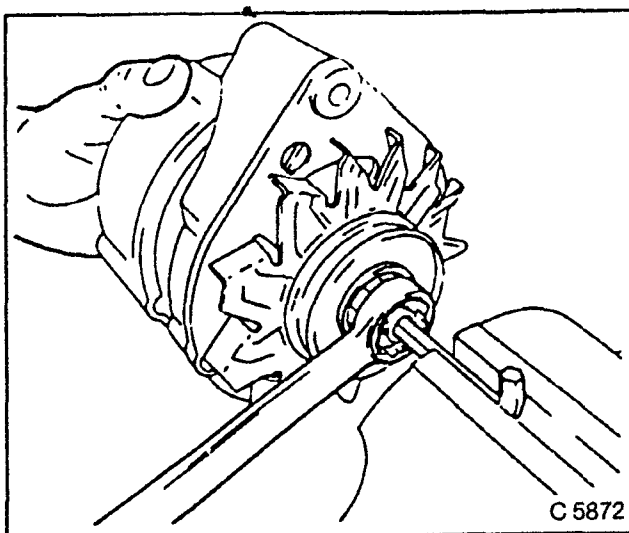
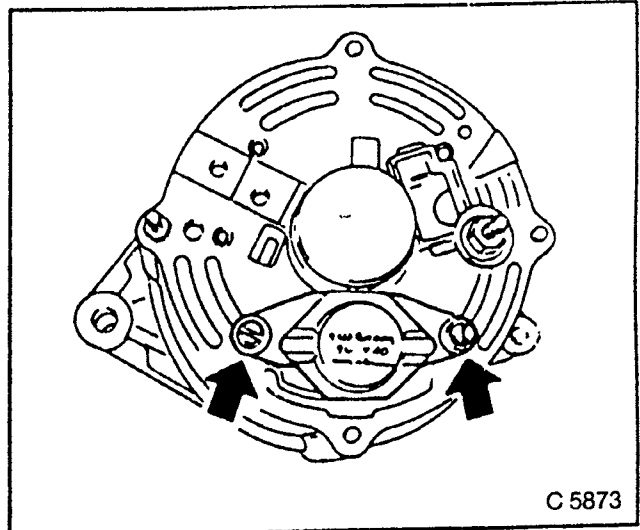


Fig. 331



**REMOVE, DISCONNECT**

1. Voltage regulator with brush holder.

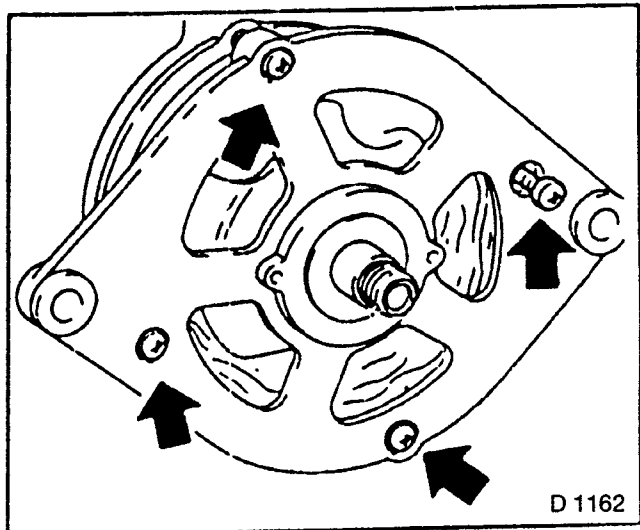


C 5873

Fig. 332

**REMOVE, DISCONNECT**

1. Mark position of drive bearing to slip ring bearing.
2. Drive bearing with claw — pole rotor.
3. Four fastening bolts.

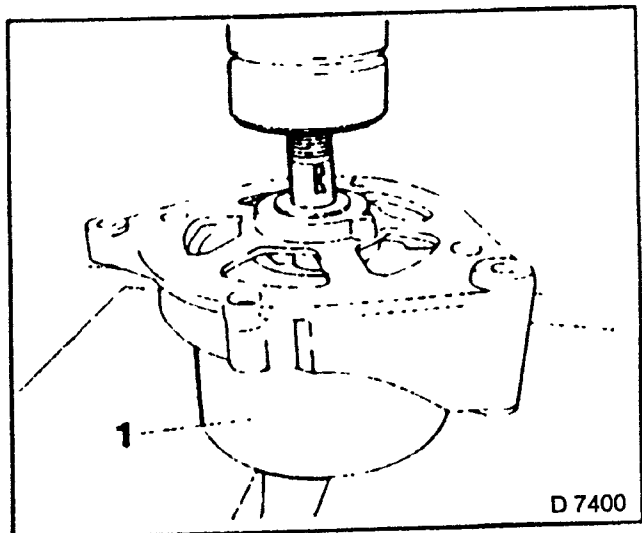


D 1162

Fig. 333

**REMOVE, DISCONNECT**

1. Claw — pole rotor from drive bearing.
2. Lay suitable pipe piece (1) underneath.

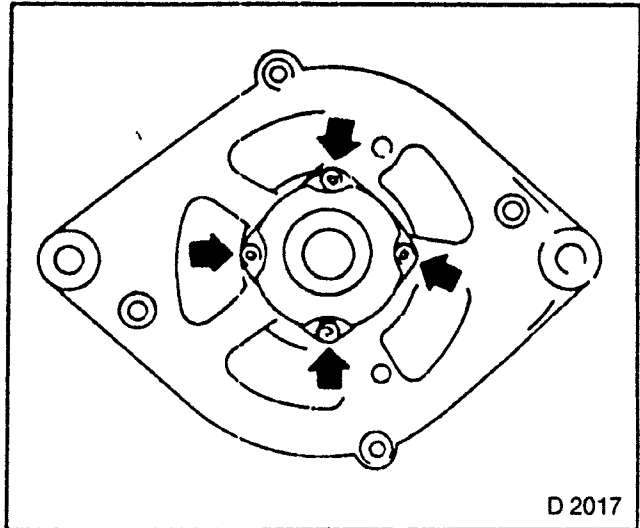


D 7400

Fig. 334

**REMOVE, DISCONNECT**

1. Bearing cover of drive bearing.
2. Ball bearing from drive bearing.

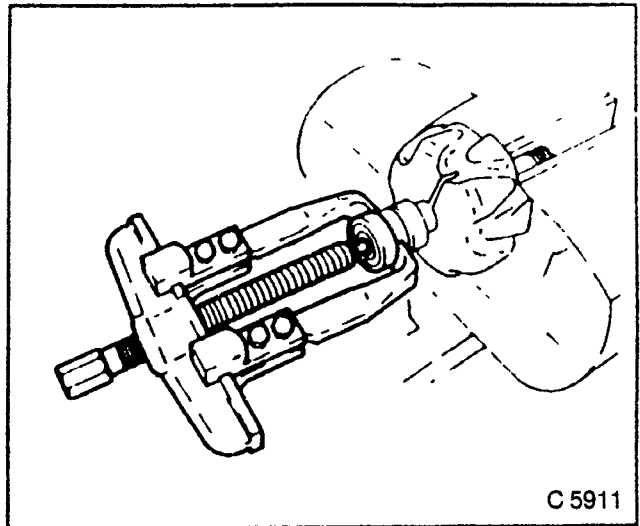


D 2017

Fig. 335

**REMOVE, DISCONNECT**

1. Ball bearing from rotor shaft.

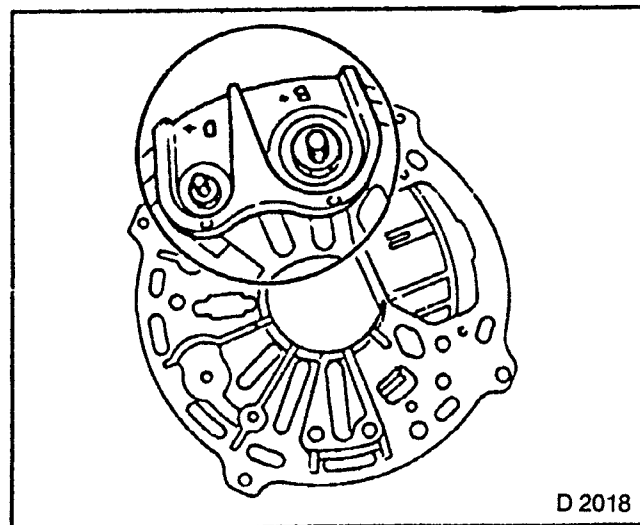


C 5911

Fig. 336

**REMOVE, DISCONNECT**

1. Nut from connecting pins "B +" and "D +".
2. Washers and insulating material.



D 2018

Fig. 337

**REMOVE, DISCONNECT**

1. Diode plate.
2. Remove together with stator winding from slip ring bearing.
3. Splash guard sleeve (if present).

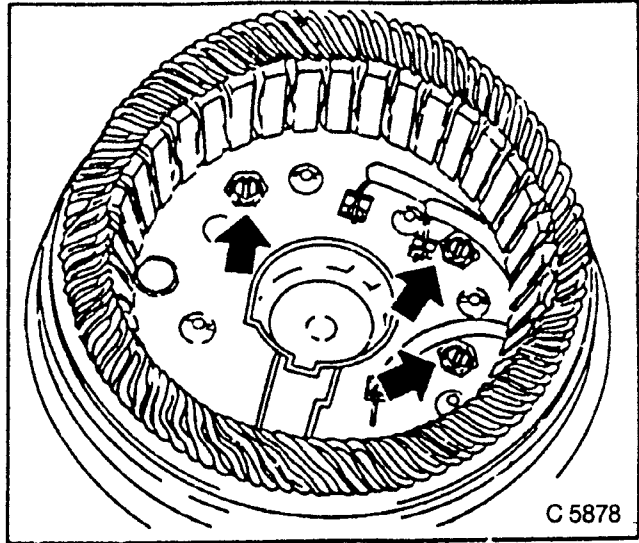


Fig. 338

**REMOVE, DISCONNECT**

1. Carefully bend off diode plate.
2. Unsolder stator winding from diode plate.

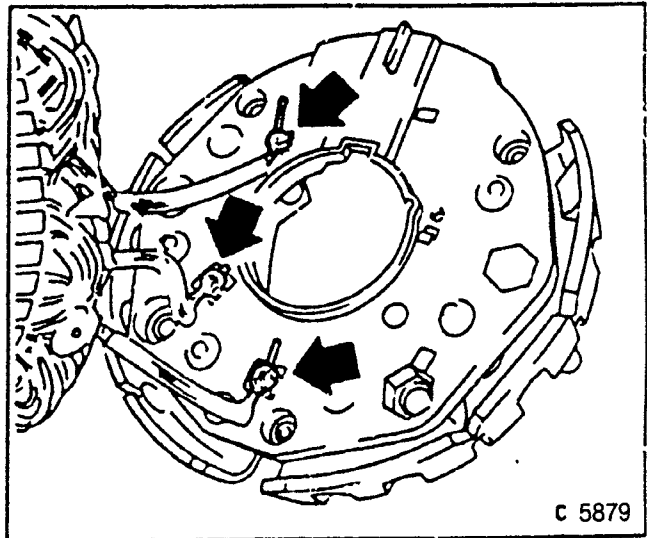


Fig. 339

**INSTALL, CONNECT**

1. Ball bearing (1).
2. Press onto rotor shaft — KM-151.
3. Ball bearing.
4. Press into drive bearing, install bearing cover.

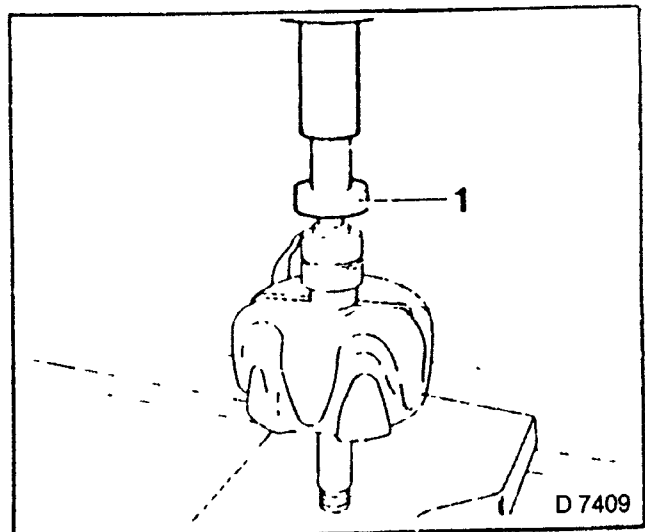


Fig. 340

**INSTALL, CONNECT**

1. Install claw — pole rotor into drive bearing.
2. Press spacing washer (1) onto rotor shaft — KM-151.

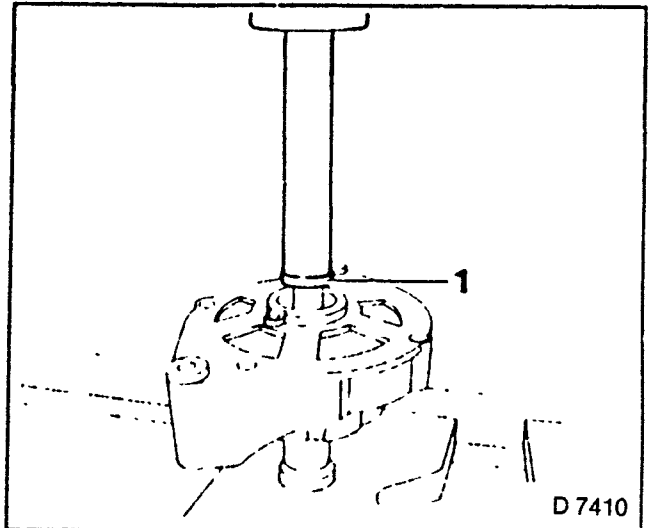


Fig. 341

**INSTALL, CONNECT**

1. Stator winding.
2. Solder phase sections to diode plate.
3. Grease ball bearing (if necessary) with Bearing Grease BO 400852.
4. Install diode plate with stator winding.
5. Note insulating sleeve for connecting pin.
6. Splash guard sleeve (if present).
7. Drive bearing and slip ring bearing on mark made previously.

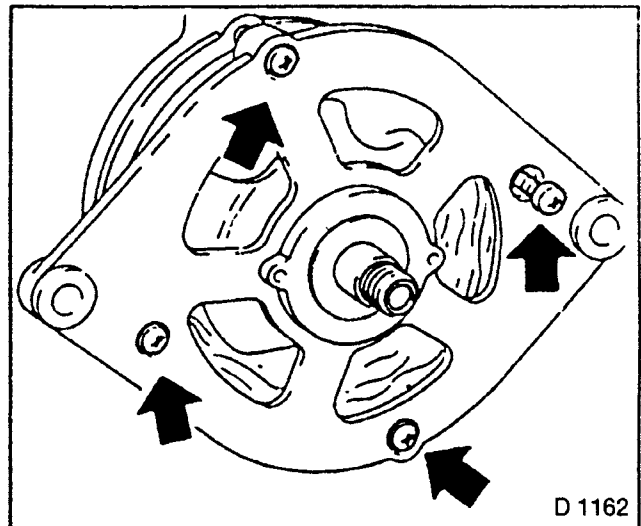


Fig. 342

**TIGHTEN (TORQUE)**

1. Housing bolts — 3,5 to 5,5 Nm.
2. Spring ring.
3. Washer.
4. Belt pulley halves.
5. Spacing ring.
6. Spring washer.
7. Fan wheel.
8. Pulley nut — 35 to 45 Nm.

# Bosch Alternator — Overhaul

## DISASSEMBLE

1. Alternator.

## CLEAN

1. Alternator individual parts.
2. Cleaning petrol (commercially available)  
— only brief contact permissible.

## INSPECT

1. Ball bearing — replace if necessary.
2. Phases of stator winding — for short circuit to ground.
3. Use ohmmeter — nominal value: resistance infinite.
4. Replace stator with short circuit to ground.

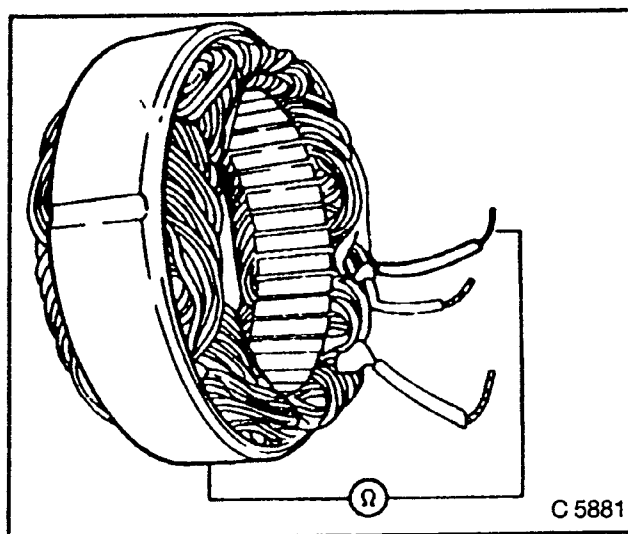


Fig. 343

## INSPECT

1. Phases of stator winding — for short-circuited turn.
2. Use ohmmeter.
3. Resistance of two phases against one another: see Technical Data.
4. Replace stator with short-circuited turn.

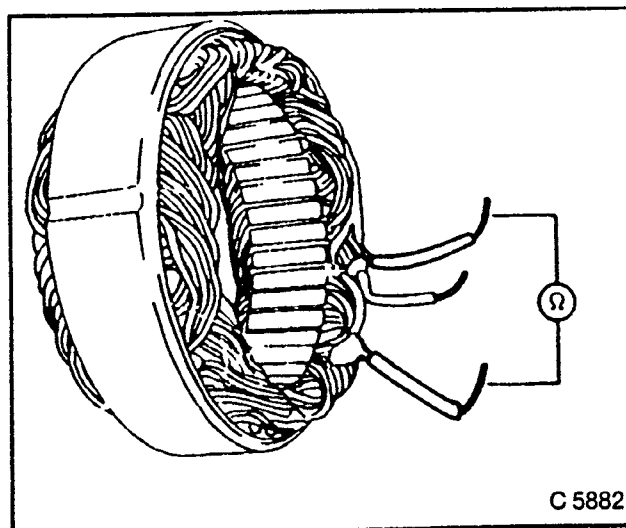


Fig. 344

**INSPECT**

1. Rotor winding — for short circuit to ground.
2. Use ohmmeter — nominal value: resistance infinite.
3. Replace rotor with short circuit to ground.

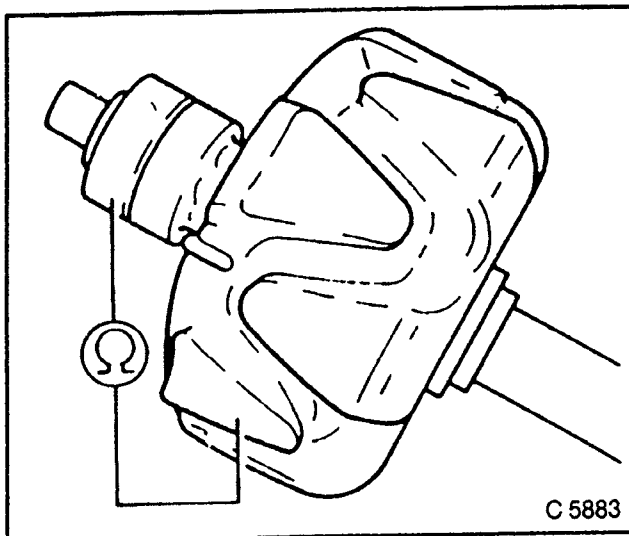


Fig. 345

**INSPECT**

1. Rotor winding — for short-circuited turn.
2. Use ohmmeter.
3. Resistance of slip rings against one another: See Technical Data page 312.
4. Replace rotor with short-circuited turn.

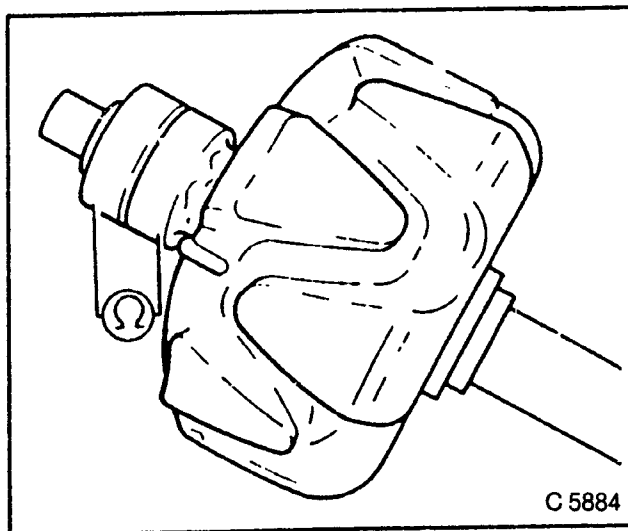


Fig. 346

**CLEAN**

1. Disconnect slip rings on lathe — emery cloth.

**INSPECT**

1. Slip rings — for-out-of-round, permissible variation: 0,03 mm.
2. Turn unoven slip rings on lathe — do not fall below dimension. See Technical Data page 312.
3. Polish and clean slip rings.

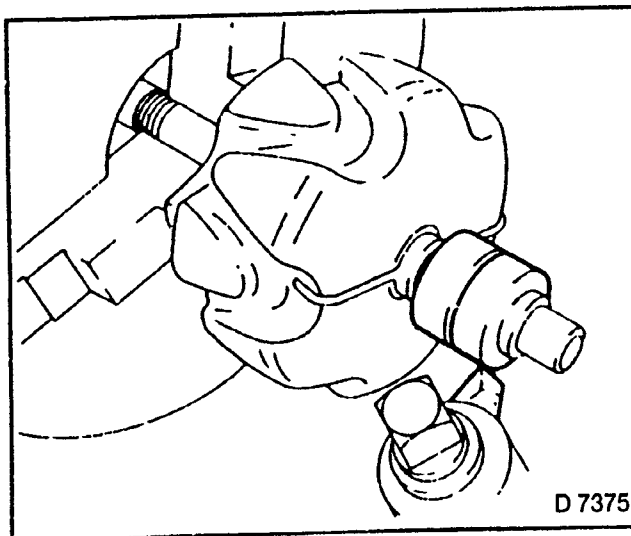


Fig. 347

**INSPECT**

1. Carbon brushes — for wear.  
Minimum length "A" — 5 mm.
2. Replace worn carbon brushes.

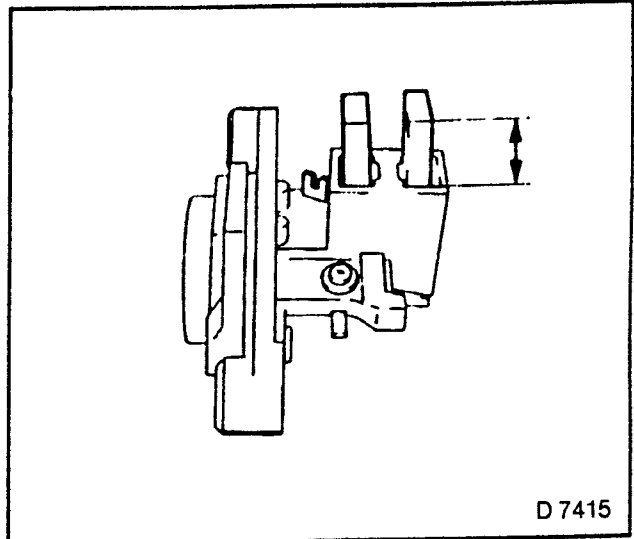


Fig. 348

**INSPECT**

1. Diodes.
2. Circuit diagram of electrically regulated alternator:
  1. Rectifier diode.
  2. Excitation diode.
  3. Stator winding.
  4. Excitation winding.
  5. Electronic voltage regulator (installed).
  6. Battery.
  7. Ignition lock.
  8. Charge telltale.

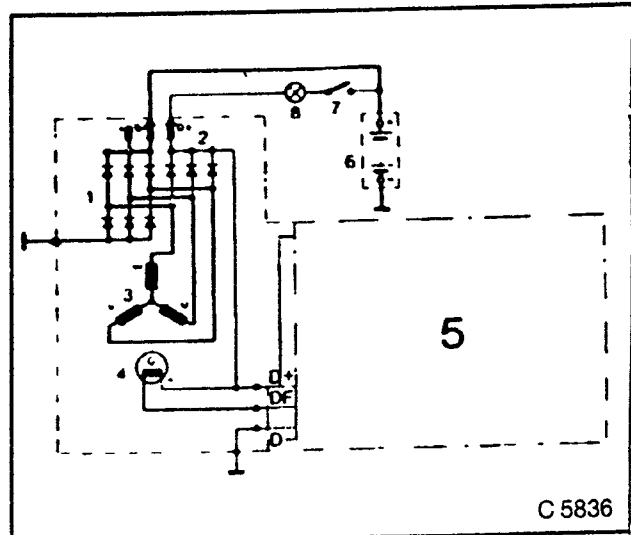


Fig. 349

**INSPECT**

1. Diodes.  
For passage, interruption, short circuit, blocking action. Test result gives only qualitative information about the effectiveness and the condition of diodes barrier layer. If an exact check of the diodes is to be undertaken, diode — checking equipment should be used. If a diode is faulty, the whole diode plate should be replaced. The described check for test lamps is carried out at a voltage of 24 volts maximum.

**INSPECT**

1. Negative diodes (1).
2. Positive probe (2) to diode housing.
3. Negative probe (3) to diode connection.
4. Test lamp should illuminate.
5. Exchange probes — see Fig. 350.
6. Test lamp should not illuminate.
7. Negative diodes have passage from housing to connections; they block in opposite direction.

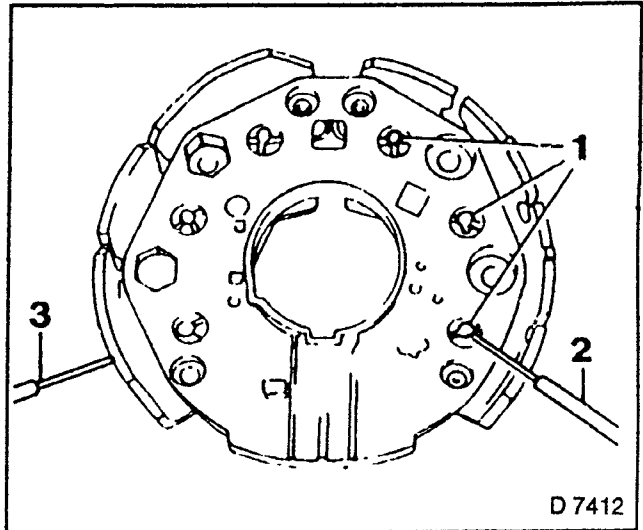


Fig. 350

**INSPECT**

1. Positive diodes (1)
2. Positive probe (2) to diode connection.
3. Negative probe (3) to diode housing.
4. Test lamp should illuminate.
5. Exchange probes.
6. Test lamp should not illuminate.
7. Positive diodes have passage from connection to housing and block in opposite direction.

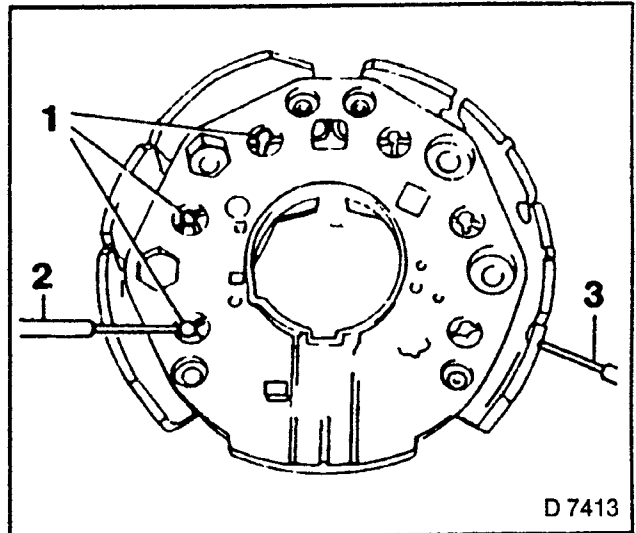


Fig. 351

**INSPECT**

1. Excitation diodes (1).
2. Positive probe (2) to diode connection.
3. Negative probe to contact rail (3).
4. Test lamp should illuminate.
5. Exchange probes.
6. Test lamp should not illuminate.

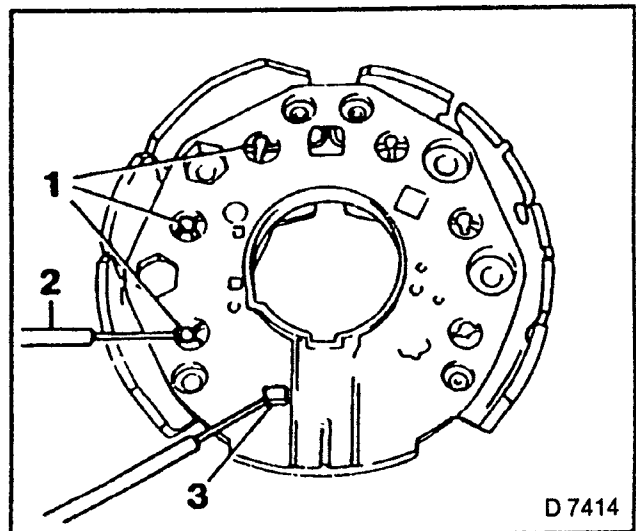


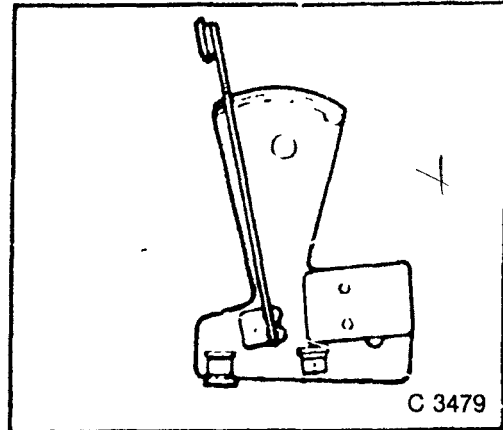
Fig. 352



## Special Service Tools

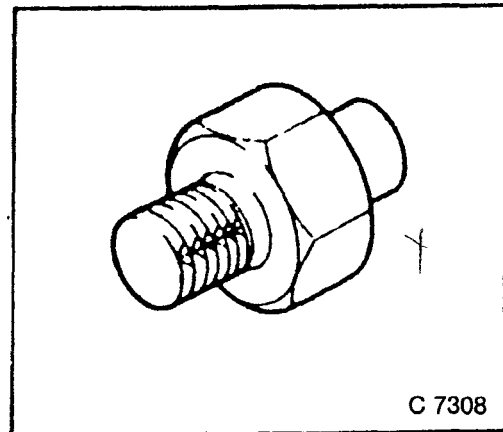
### KM-128-A BELT TENSION GAUGE

To check V-belt tension.



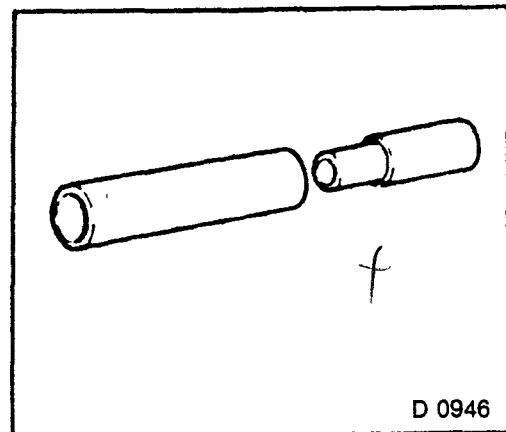
### KM-135 ADAPTER

To measure engine oil pressure in conjunction with KM-498-B.



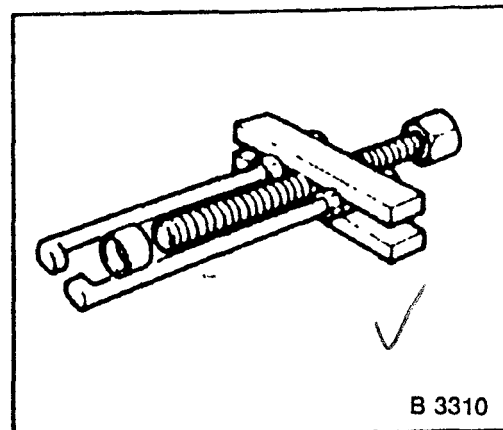
### KM-151 REMOVER/INSTALLER (no longer available)

To remove and install the needle bearing of the alternator.



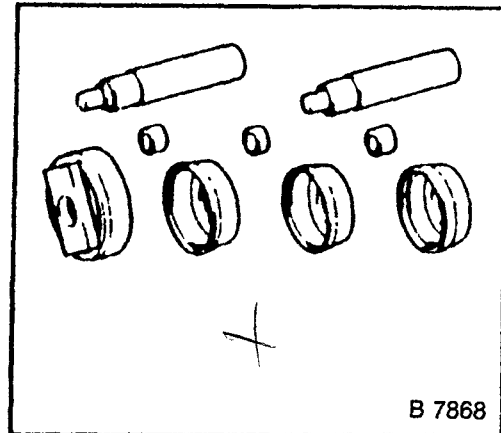
### KM-210-A STEERING WHEEL PULLER

To remove the toothed belt pulley in conjunction with KM-516 and KM-647.

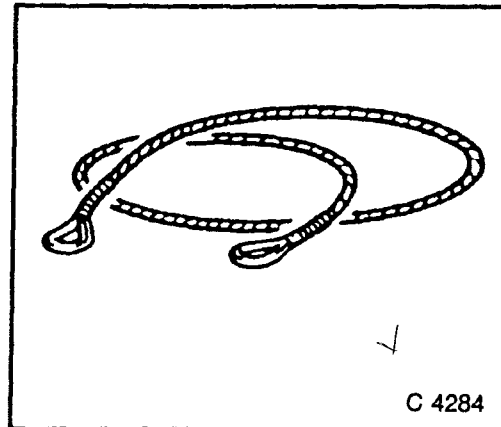


**KM-235-D RING INSTALLER**

To install seal ring in crankshaft bearing.

**KM-252-2-A ENGINE LIFTER**

To remove and install the engine.



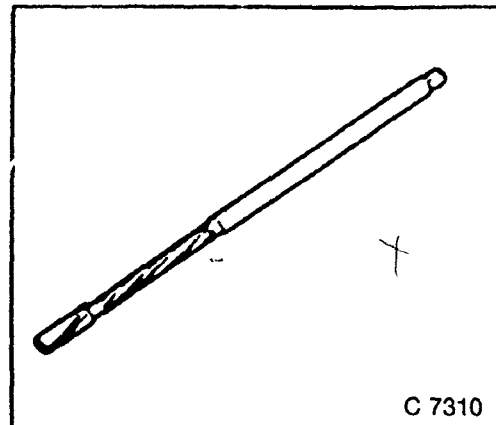
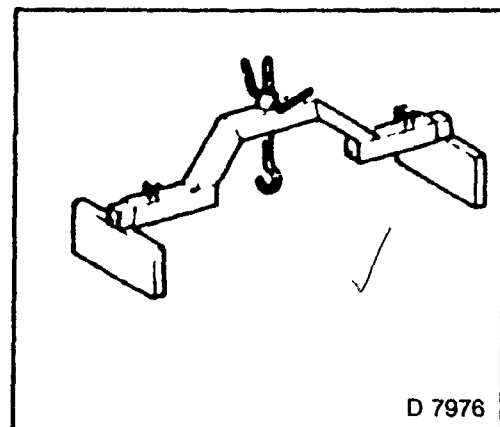
**KM-253 REAMER 0,075 MM OVERSIDE \*)**

**KM-254 REAMER 0,150 MM OVERSIZE \*)**

**KM-255 REAMER 0,250 MM OVERSIZE \*)**

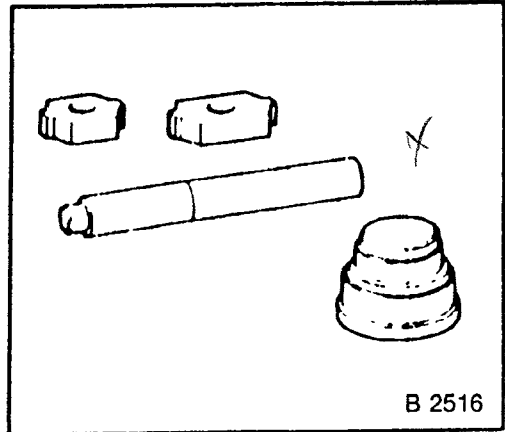
\*) No longer available.

To ream the valve guide bore

**KM-263-B LIFTER/HOLDER**

**KM-266-A REMOVER/INSTALLER**

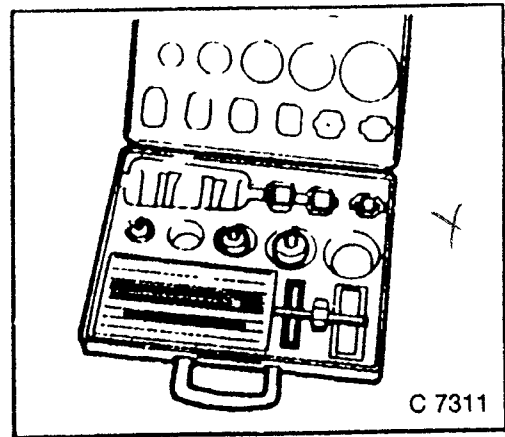
To install starter bearing bushings/install  
TDC sensor sleeve.



B 2516

**KM-340-C CUTTER SET**

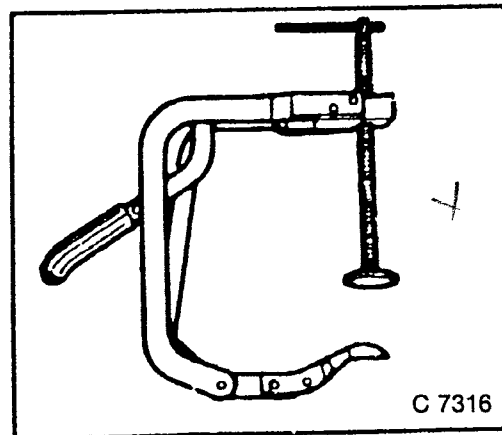
To cut and correct valve seating.



C 7311

**KM-348 SPRING COMPRESSOR**

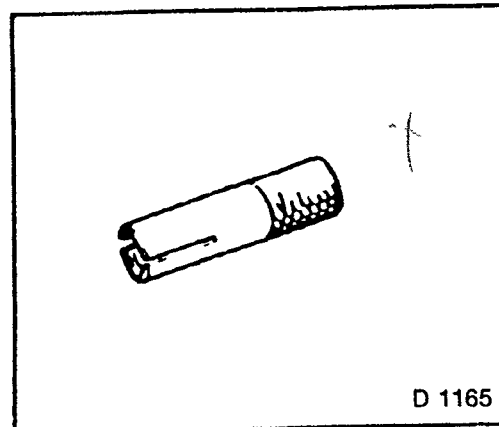
To compress valve springs, cylinder head  
removed.



C 7316

**KM-352 INSTALLER**

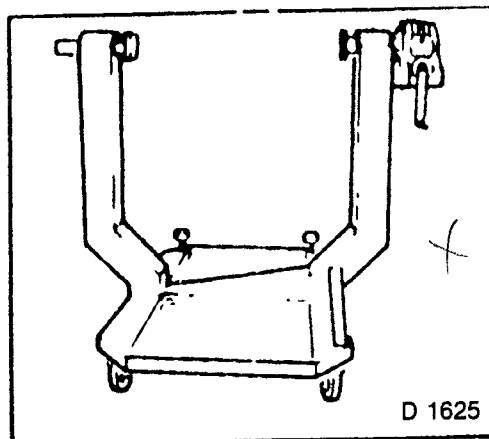
To install the valve stem sealing.



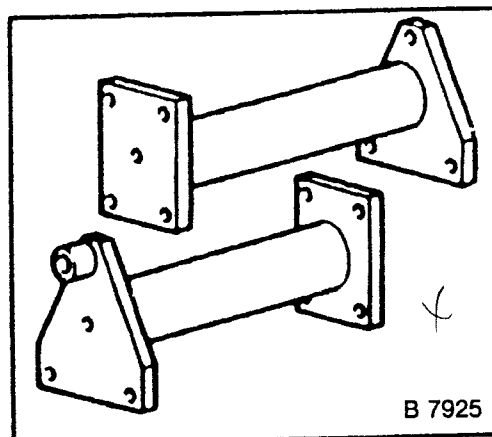
D 1165

**KM-412 ENGINE OVERHAUL STAND**

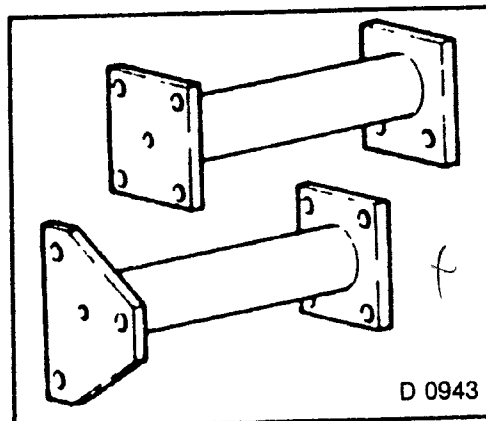
To hold removed engine.

**KM-412-8 ADAPTER (1,8/2,0 ltr.)**

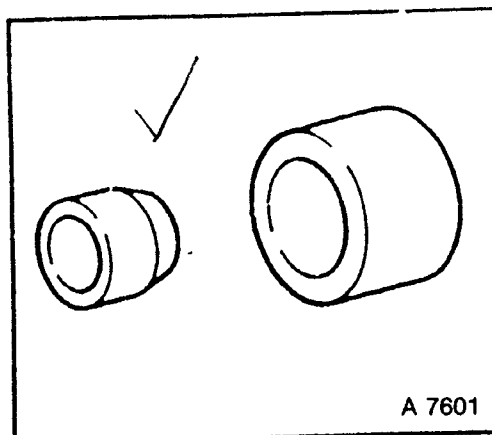
To hold engine in conjunction with KM-412

**KM-412-10 ADAPTER (1,4/1,6 ltr.)**

To hold engine in conjunction with KM-412.

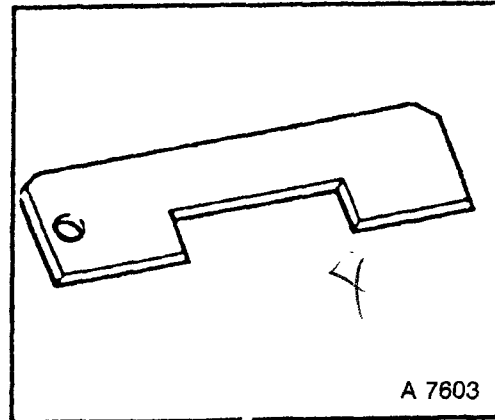
**KM-417 INSTALLER**

To install crankshaft seal ring into oil pump housing.

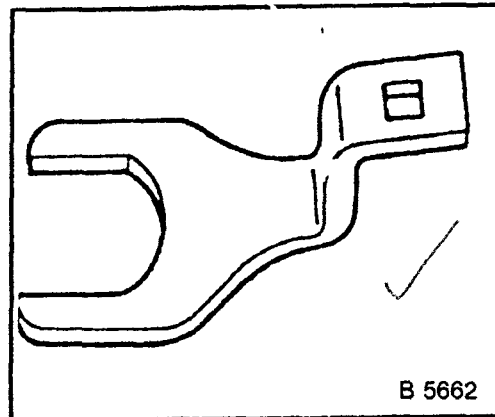


**KM-419 DISTANCE GAUGE**

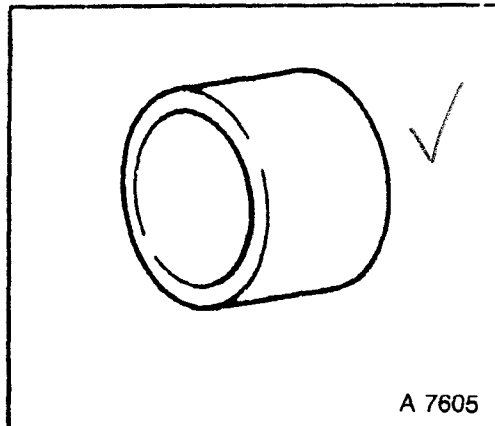
To check projection to valve guide after reworking valve seat.

**KM-421-A ADJUSTING WRENCH**

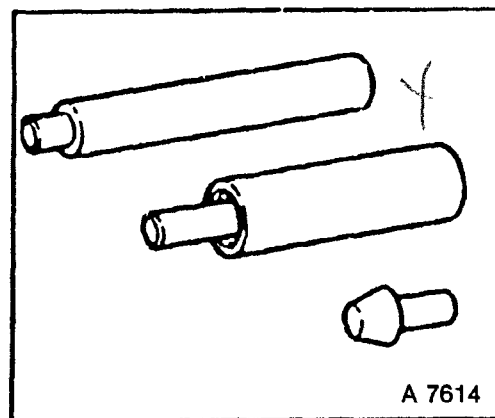
To adjust tension of toothed belt.

**KM-422 INSTALLER**

To install seal ring into camshaft carrier.

**KM-427 INSTALLER**

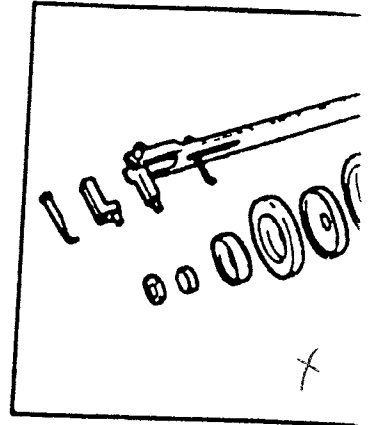
To install guide pins into engine block.



ENGINE

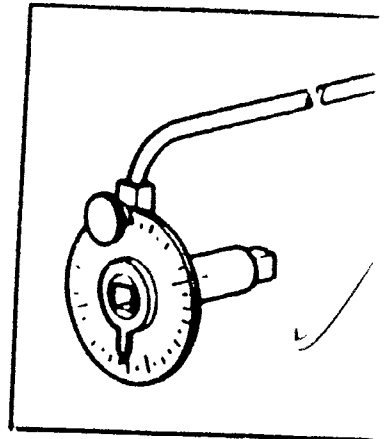
**KM-469-A REMOVER/INSTALLER**

To remove and install crankshaft seal ring.



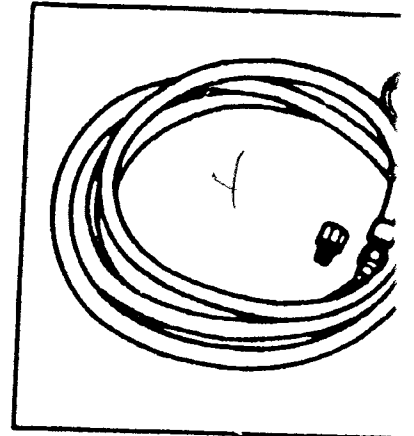
**KM-470-B ANGULAR TORQUE WRENCH**

To tighten cylinder head bolts.



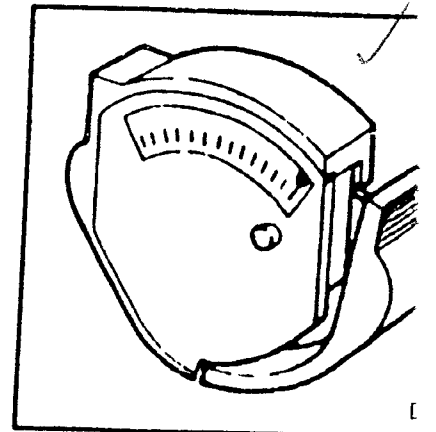
**KM-498-B PRESSURE GAUGE**

To check engine oil pressure in conjunction with KM-135.



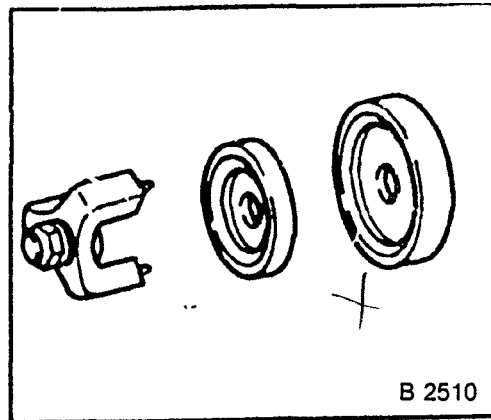
**KM-510-A TENSION GAUGE (1,8/2,0 ltr.)**  
(For version without toothed belt tension roller)

To check and adjust toothed belt tension.

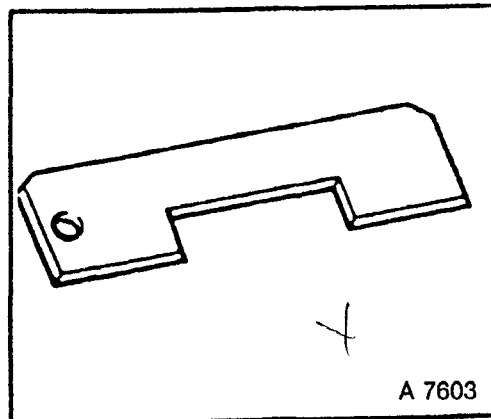


**KM-511 INSTALLER**

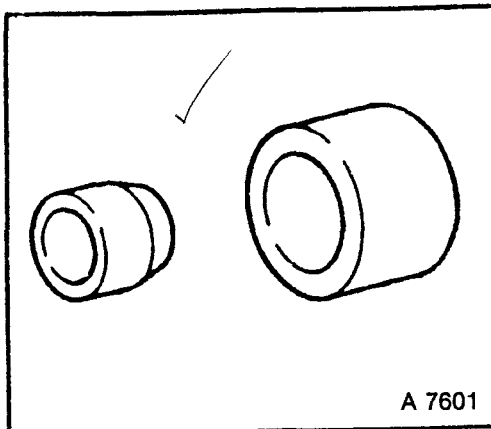
To install crankshaft seal ring in conjunction with KM-469-A.

**KM-512 DISTANCE GAUGE**

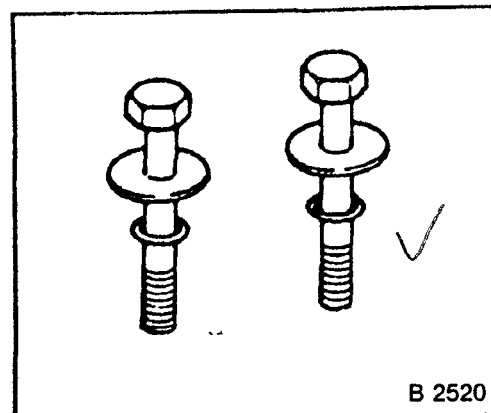
To check protrusion of valve guide after reworking valve seat.

**KM-513-A ASSEMBLY SLEEVES**

To install front crankshaft seal ring.

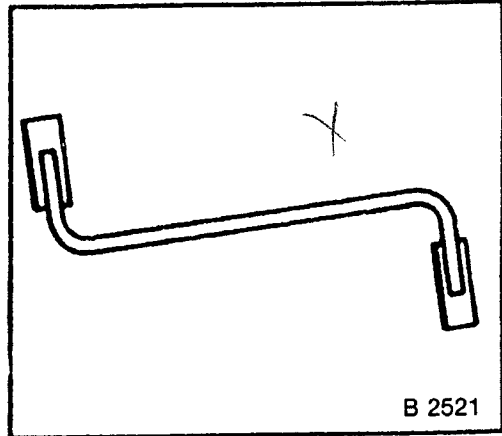
**KM-516 PULLER BOLTS**

To remove toothed belt drive pinion in conjunction with KM-210-A and KM-467.



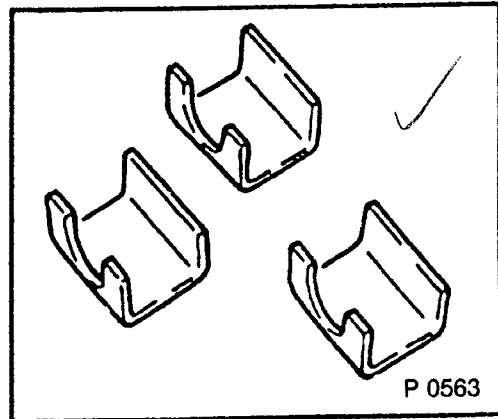
**KM-517 LOCKING DEVICE**

To lock the flywheel.



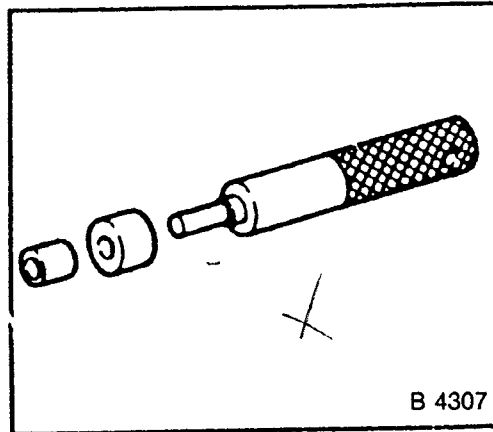
**KM-526-A CLAMPS**

Clutch assembly with 3 clamps.



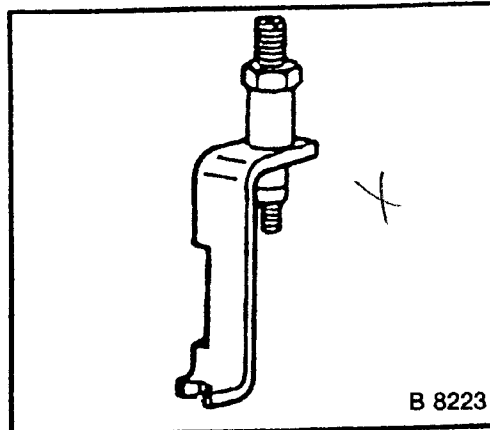
**KM-535 INSTALLER**

To install crankshaft seal ring in conjunction with KM-511 or KM-635, engine removed.



**KM-565 REMOVER/INSTALLER**

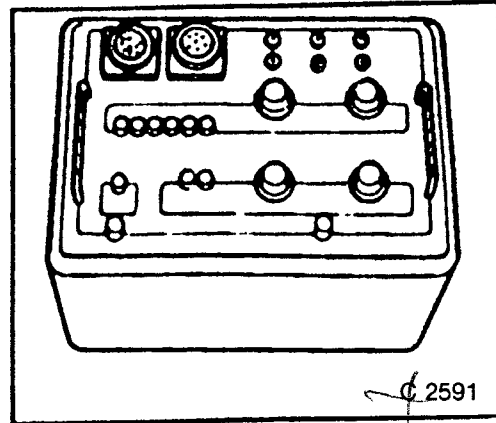
To remove and install rocker arms and valve play compensators.





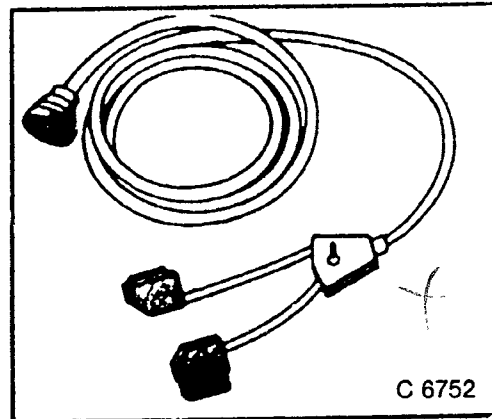
**KM-566-1 UNIVERSAL CHECKING  
ADAPTER**

To check L-Jetronic in conjunction with  
KM-566-10 and MKM-587-A.



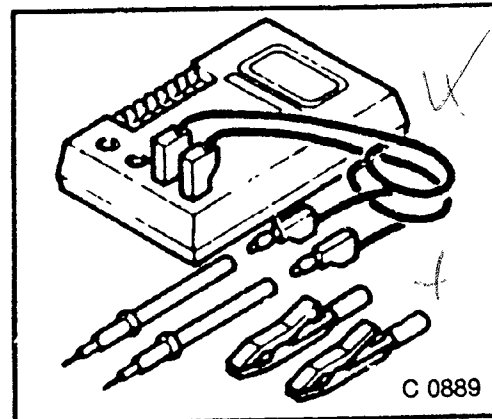
**KM-566-10 CHECKING CABLE**

To check L-Jetronic in conjunction with  
KM-566-1 and MKM-587-A.



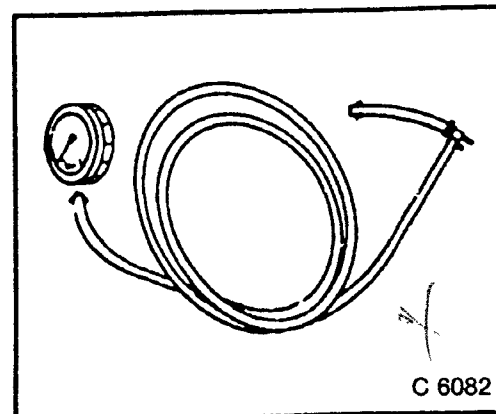
**MKM-587-A MULTIMETER**

Measurements of vehicle electronics.



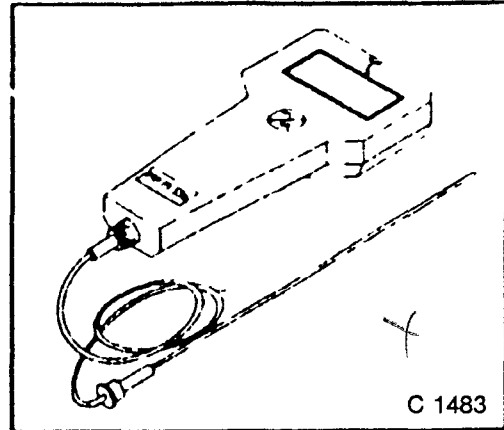
**MKM-588 PRESSURE GAUGE**

To check the fuel pressure, injection engines  
only.

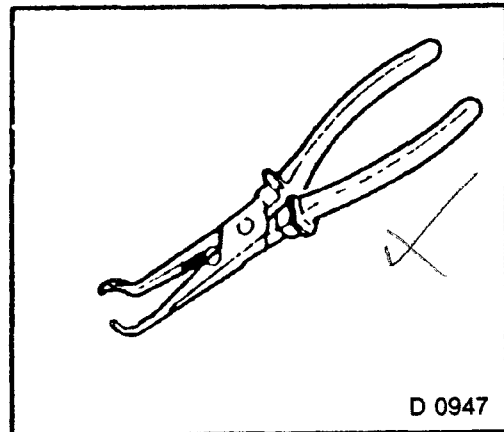


**MKM-596 GAUGE**

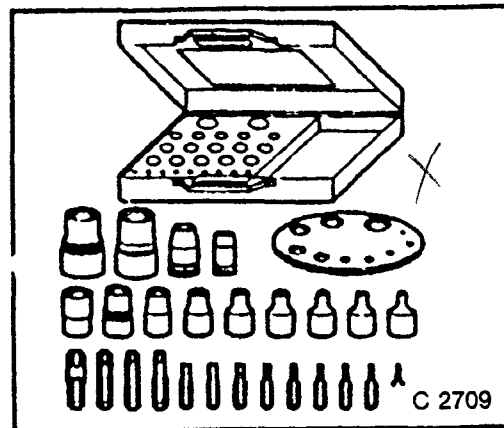
To measure oil temperature, special exhaust gas test (ASU).

**MKM-597 REMOVING PLIERS (replaced by KM-717)**

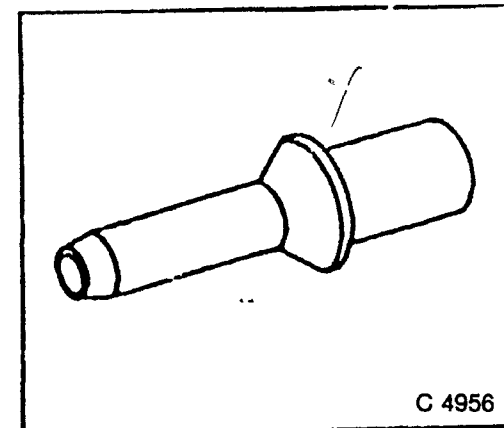
To remove spark plug connectors.

**MKM-604-B TORX BIT AND SOCKET SET**

To remove and install Torx bolts.

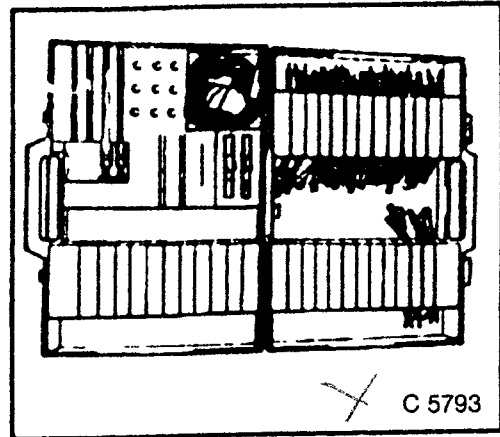
**KM-605 ADAPTER**

To connect CO tester, vehicles with open loop catalytic converter.



**KM-609 ELECTRONIC KIT I**

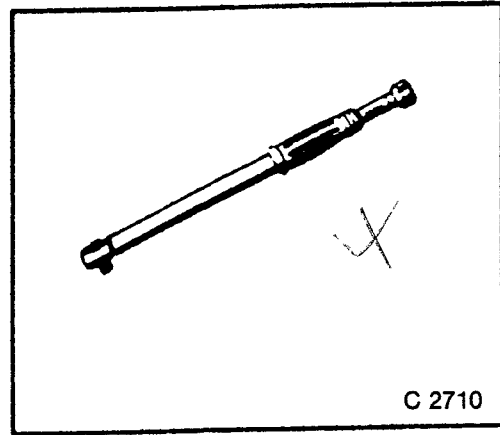
Diagnosis of electric and electronic systems.



C 5793

**MKM-610 TORQUE WRENCH 1/2" DRIVE**

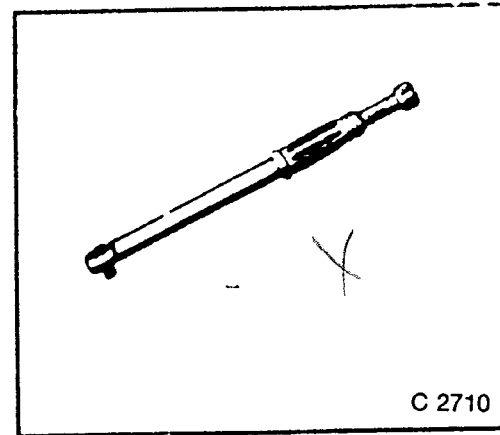
Measuring range 30 — 130 Nm.



C 2710

**MKM-611 TORQUE WRENCH 3/8" DRIVE**

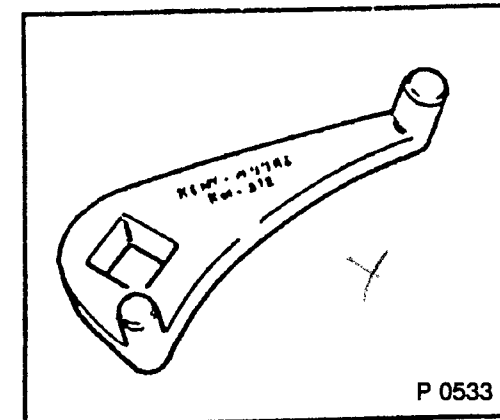
Measuring range 10 — 60 Nm.



C 2710

**KM-612 RIBBED V-BELT TENSIONER**

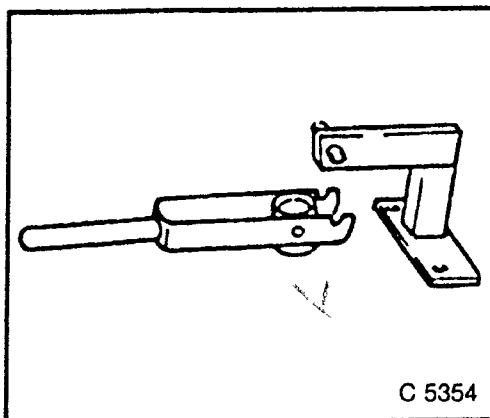
To tension ribbed V-belt, 1,6 ltr. engines with power steering.



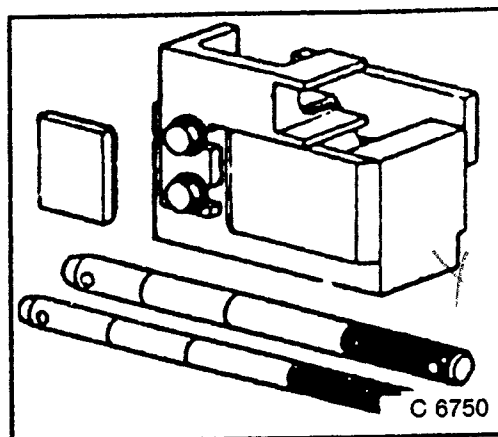
P 0533

**KM-632-A TENSIONER**

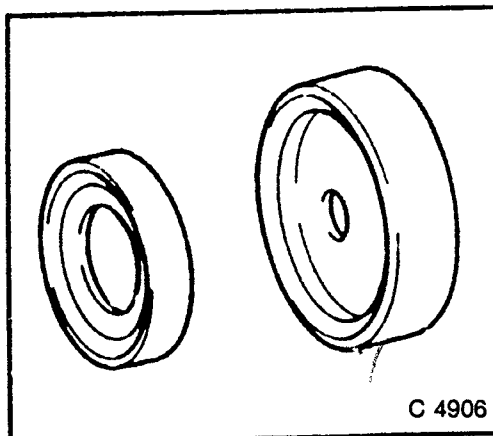
To tension clutch assembly, engine removed.

**KM-634 REMOVER/INSTALLER**

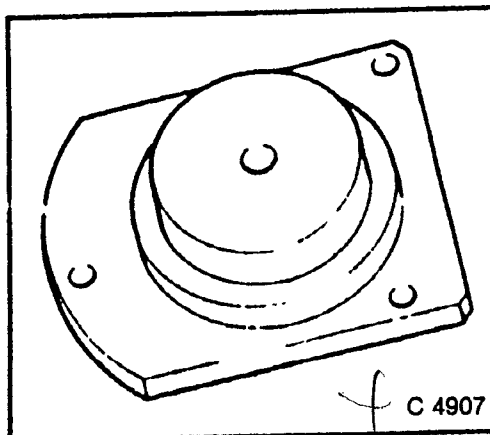
To remove and install piston pins.

**KM-635 INSTALLER**

To install rear crankshaft seal ring in conjunction with KM-469-A.

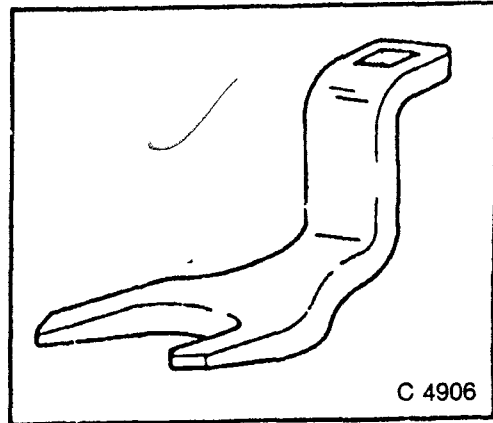
**KM-636 INSTALLER**

To install rear camshaft seal ring.

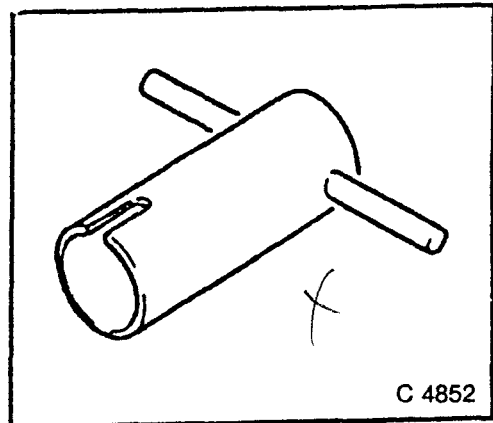


**KM-637 ADJUSTING WRENCH**

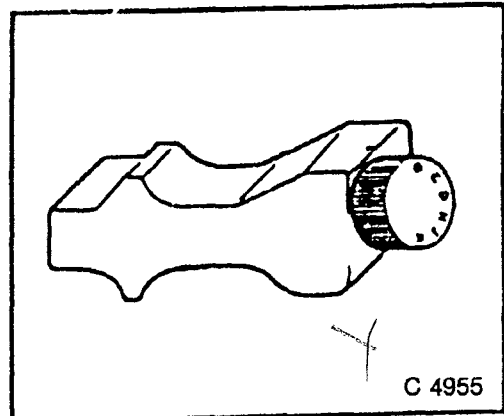
To adjust toothed belt tension.

**KM-639 REMOVER/INSTALLER**

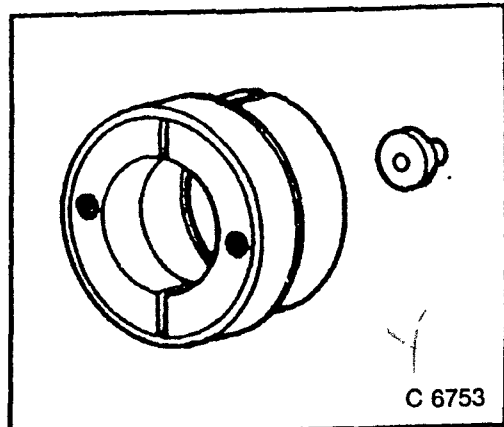
To remove and install idle cut-off valve, 2 E 3 carburettor.

**KM-640 DIAGNOSTIC SWITCH**

To trigger blink codes, engines with self-diagnosis.

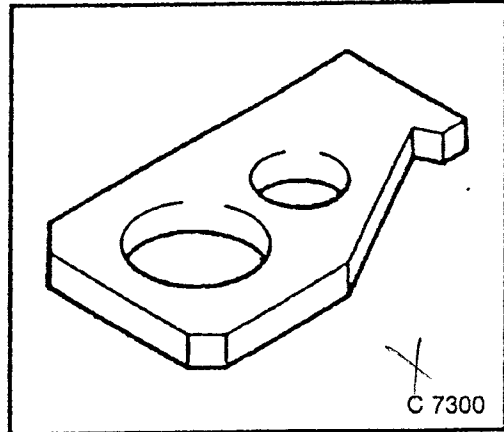
**KM-647 REMOVER**

To remove toothed belt drive gear in conjunction with M-210-A and KM-516.

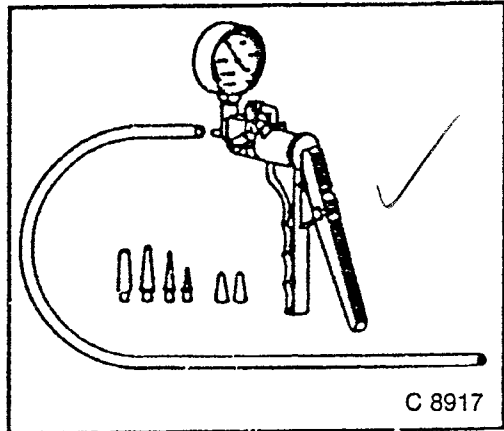


**KM-652 LOCKING DEVICE**

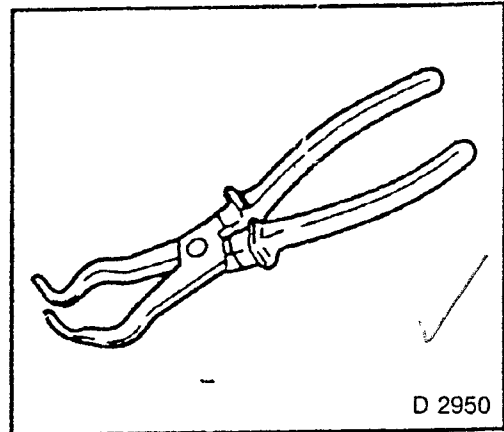
To lock flywheel.

**MKM-C67 PRESSURE AND VACUUM PUMP**

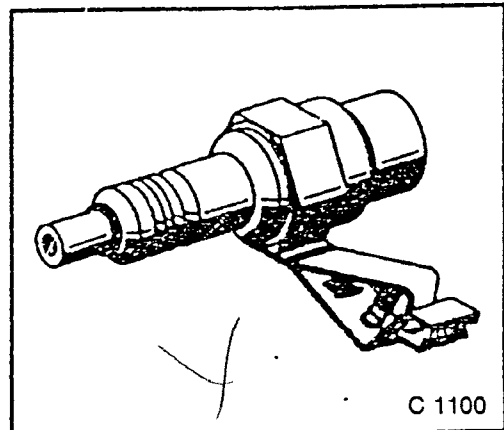
To check for leaks in vacuum unit.

**KM-717 REMOVING PLIERS**

To remove spark plug connectors.

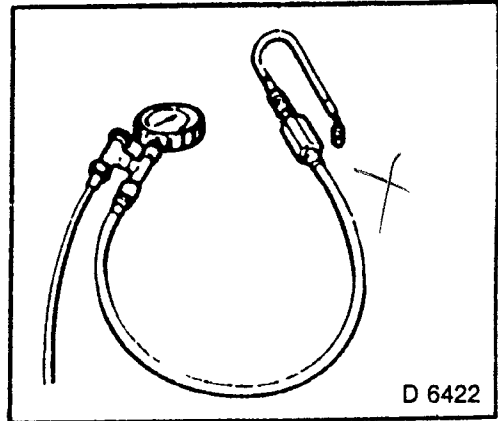
**KM-J-26792 SPARK TESTER**

To check ignition spark.



**KM-J-34730-91 FUEL PRESSURE TESTER**

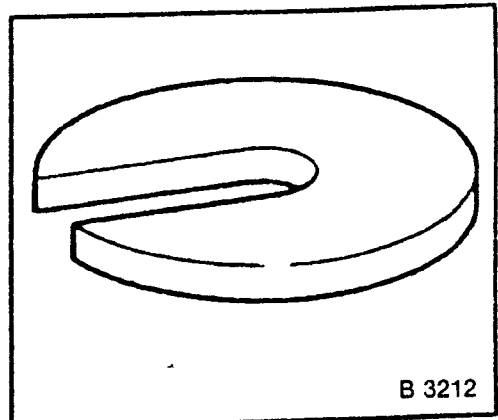
To check fuel pressure.



**Cooling System**

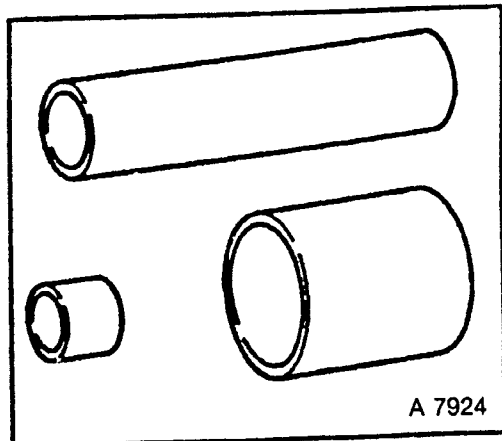
**KM-251-01 REMOVER PLATE**

To remove water pump drive and impeller.



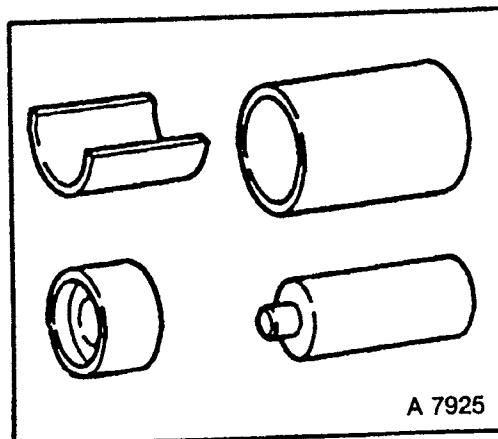
**KM-258 INSTALLER SLEEVES (no longer available)**

To disassemble and assemble water pump.



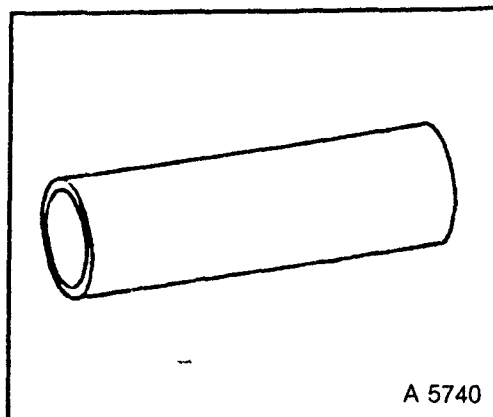
**KM-265 INSTALLER (no longer available)**

To assemble water pump.

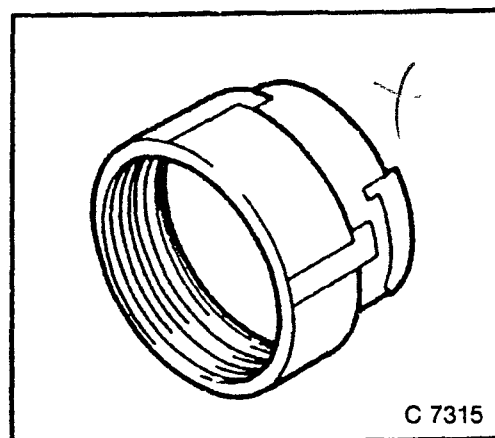


**KM-302 INSTALLER**

To install seal ring in water pump housing.

**KM-471\* ADAPTER**

To check pressurized cooling system in conjunction with cooling system tester\*.



\* Cooling system tester — see "EUROLINE" catalogue.

Diagnosis of cooling system in conjunction with KM-471.



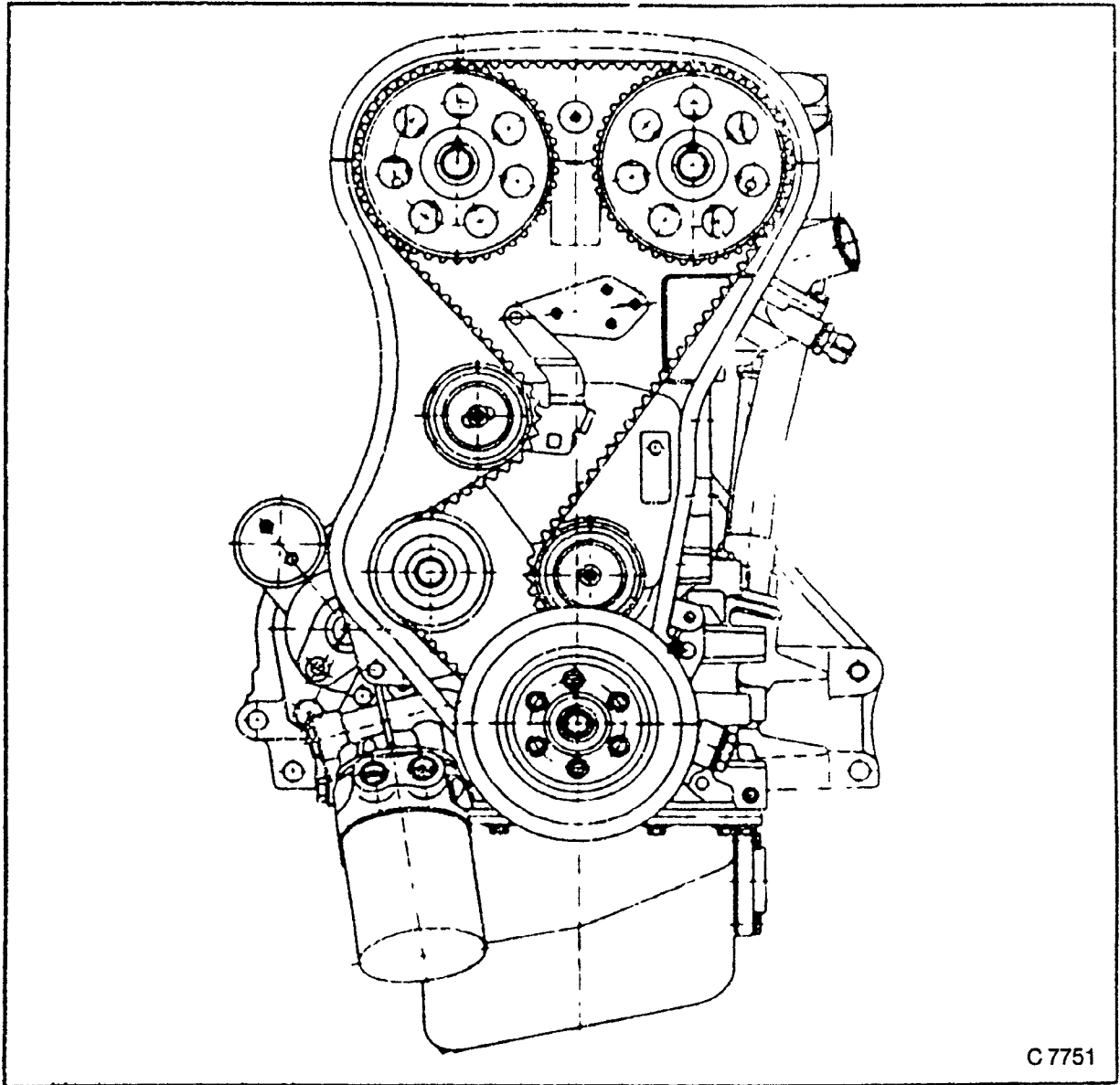
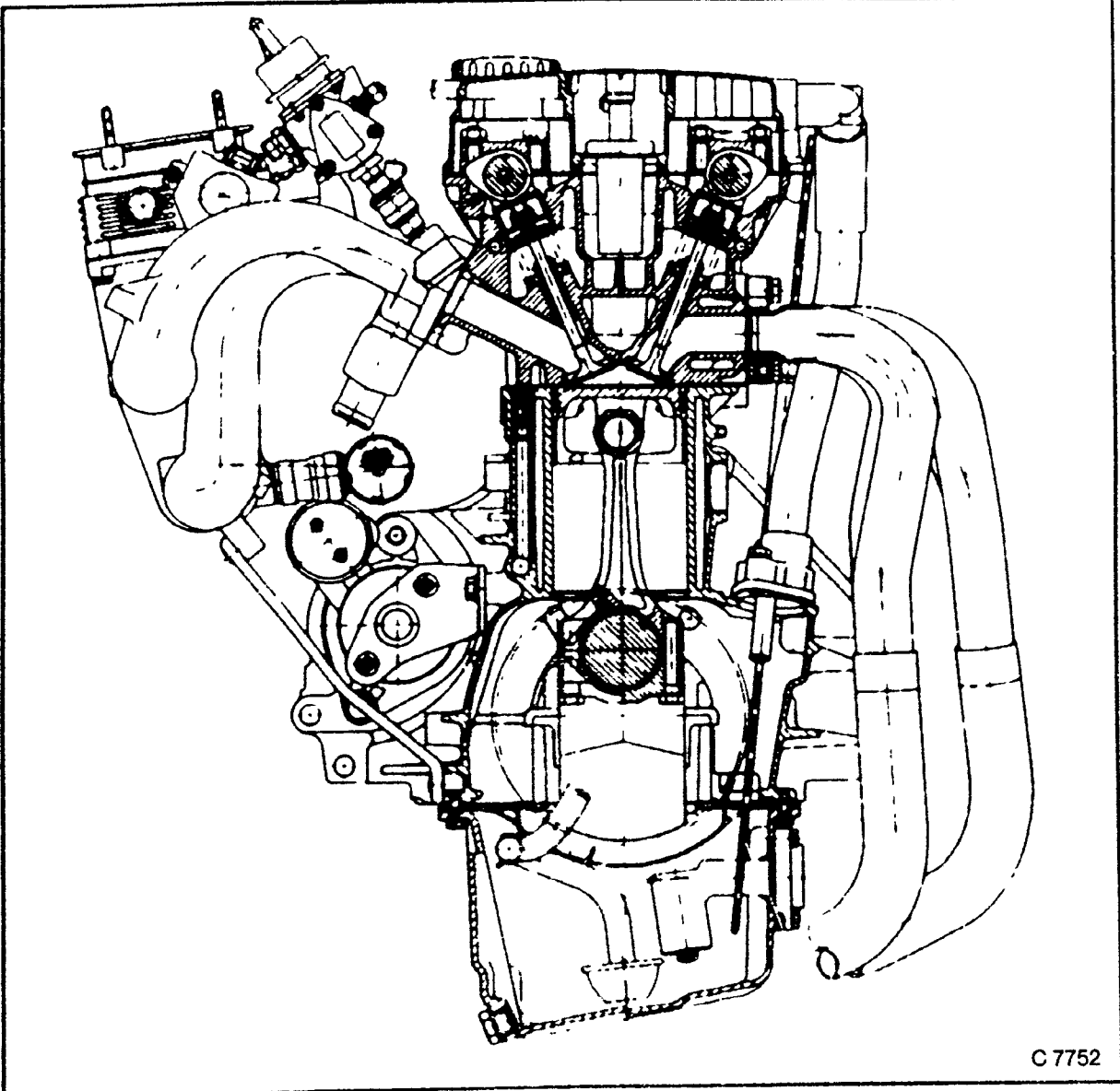


Fig 353

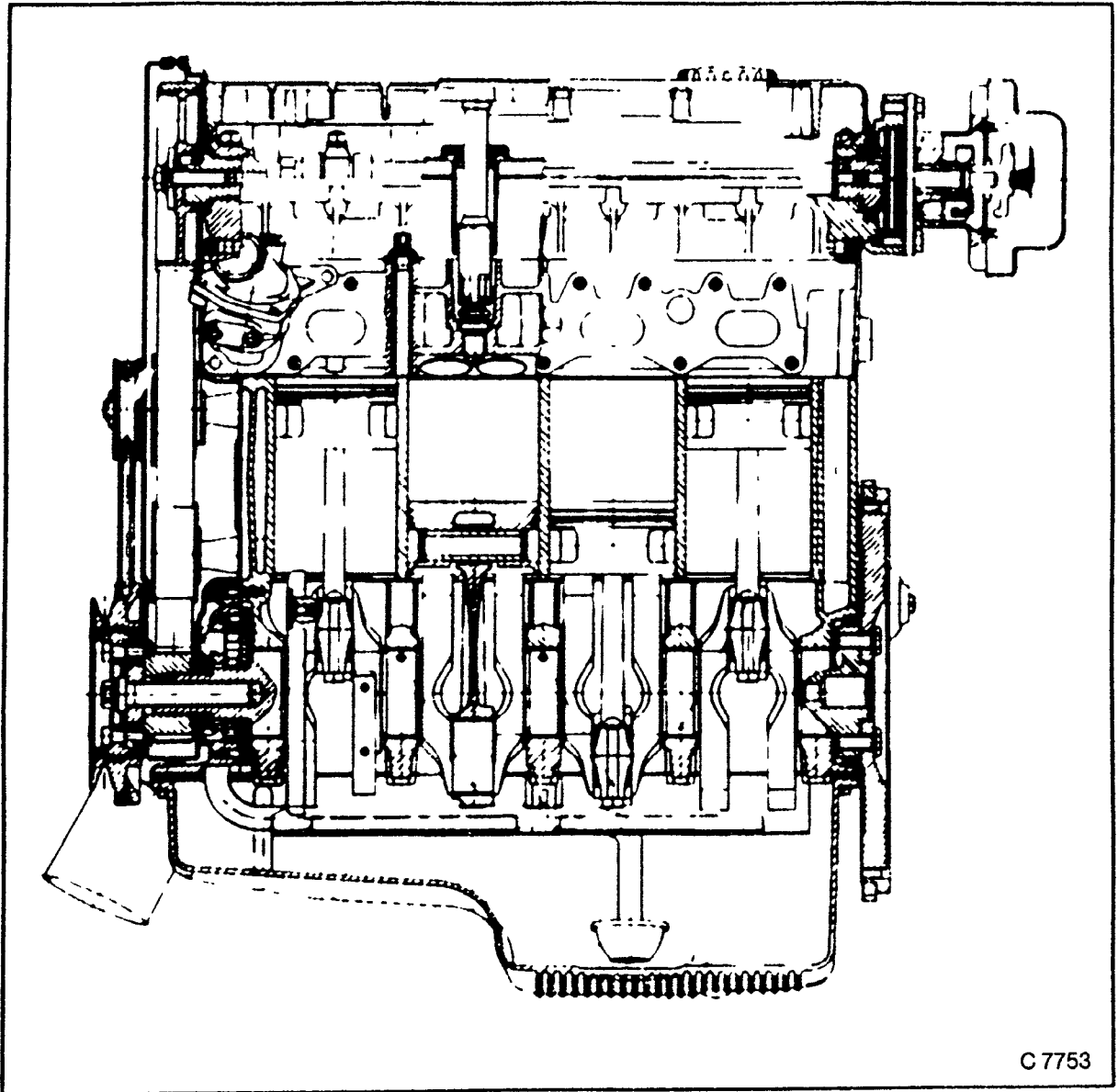
C 20 XE/E20 LET  
Engine Timing



C 7752

Fig. 354

C 20 XE  
Cross-section



C 7753

Fig. 355

C 20 XE/20 LET  
Longitudinal section

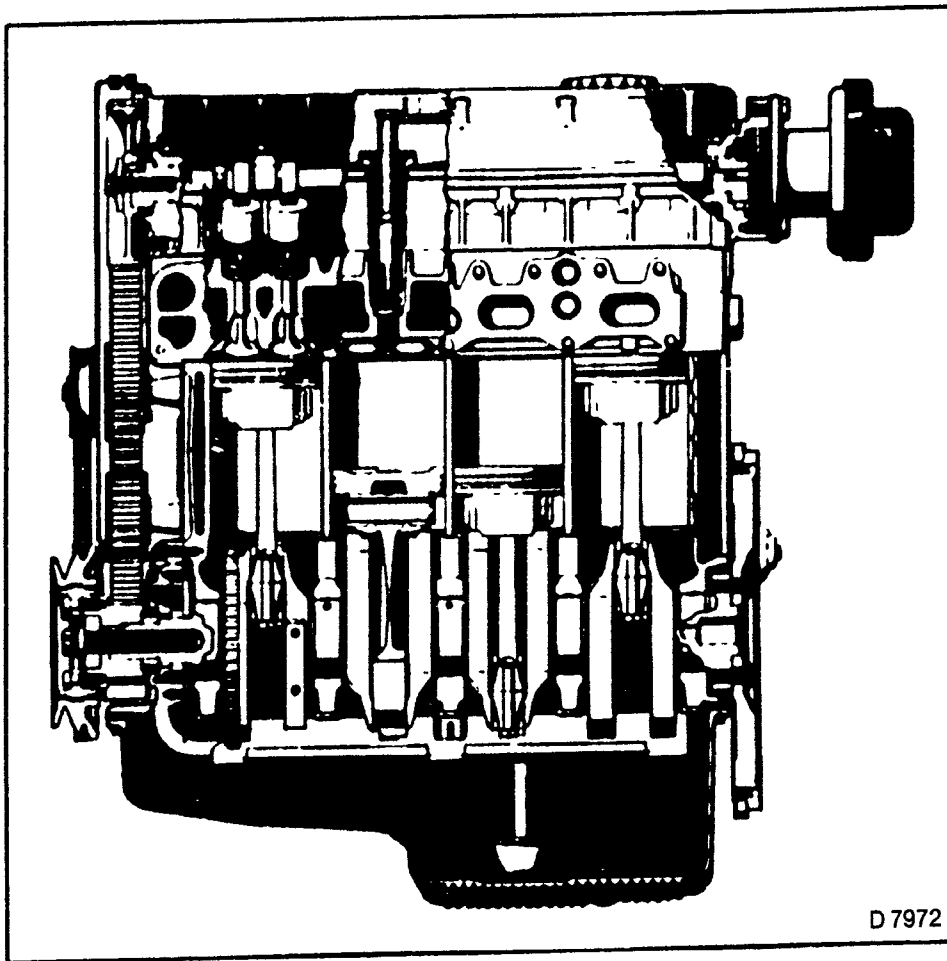


Fig. 356

C 20 LET — Side view

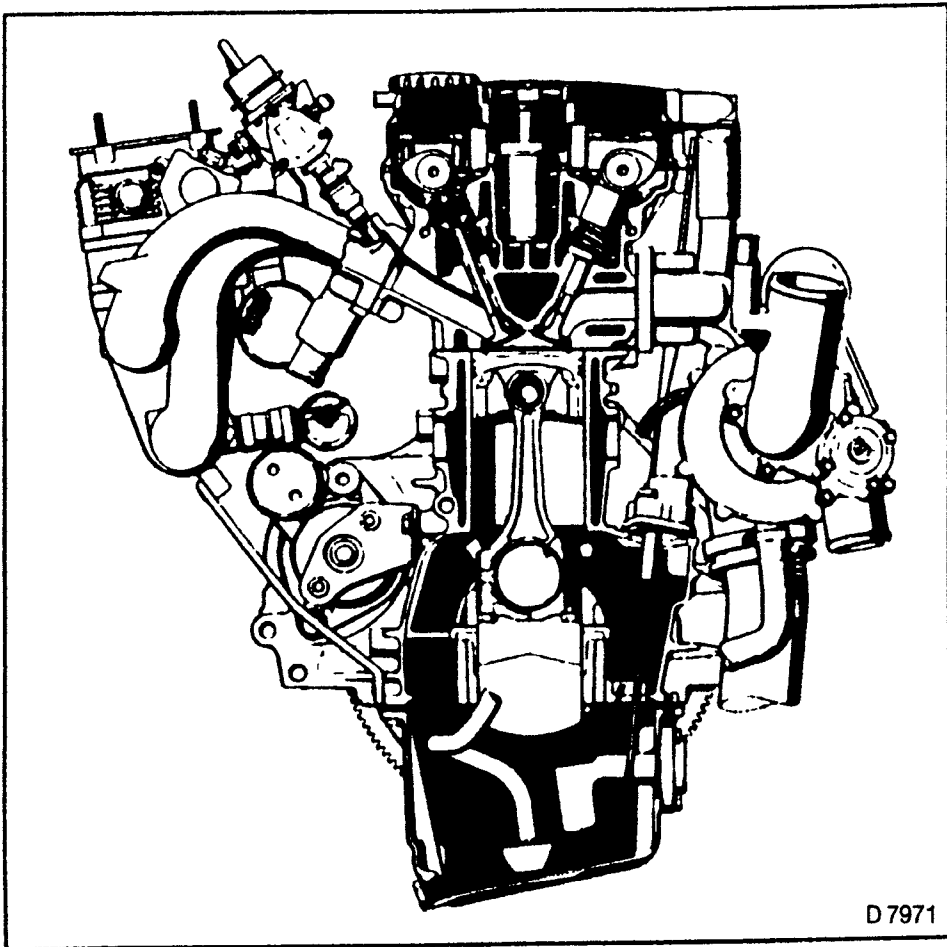
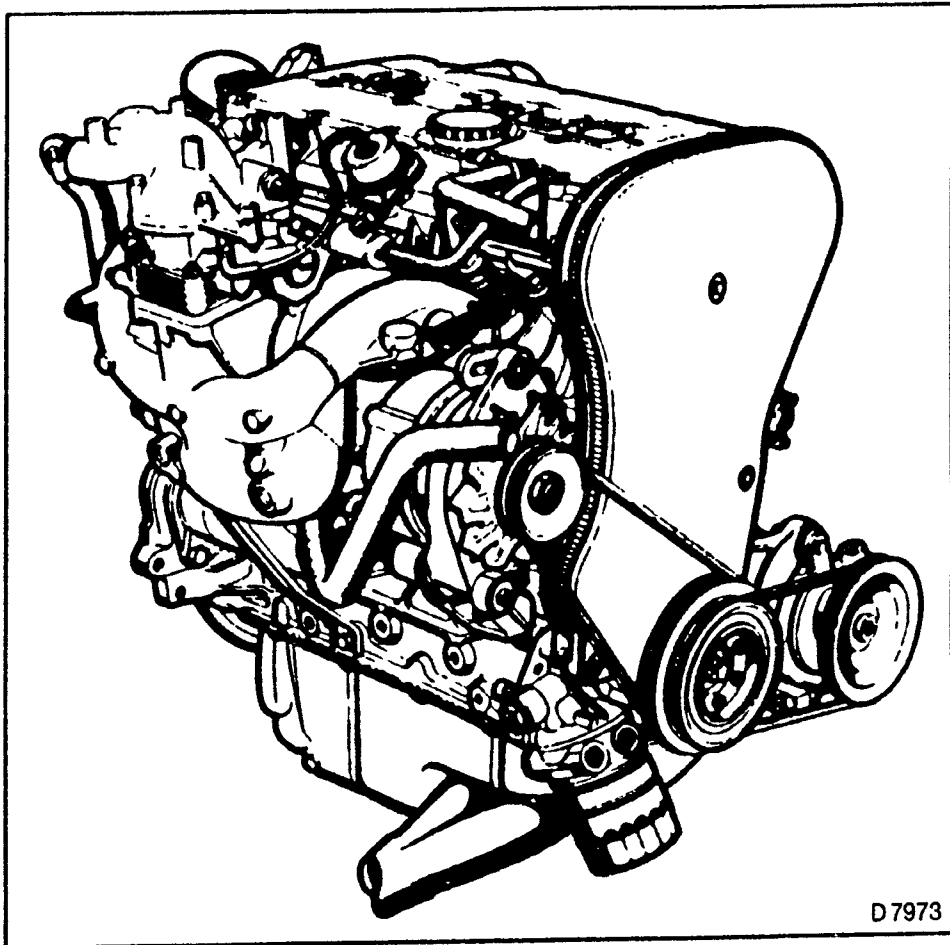


Fig. 357

C 20 LET — Cross-section



D 7973

Fig. 358

C 20 LET — Engine intake side.

# Engine checking and adjusting operations

## RECOMMENDED TORQUE VALUES

|  | Nm               |
|--|------------------|
| Ignition cable cover to cylinder head cover .....                                | 8                |
| Spark plug to cylinder head .....  | 25               |
| Tension strap to alternator (M 10) .....   | 35               |
| Tension strap to alternator (M 8) .....  | 25               |
| Clamping bracket to alternator .....   | 25               |
| Clamping bracket, alternator to intake manifold .....                            | 25               |
| Cover to throttle valve manifold .....   | 5 <sup>1)</sup>  |
| Front toothed belt cover to cylinder head, intermediate piece and oil pump ..... | 8                |
| Oxygen sensor to exhaust diverter manifold .....                                 | 30 <sup>1)</sup> |

<sup>1)</sup> C 20 LET only

## Compression — Check

### REMOVE, DISCONNECT

- 1 Remove Fuse No. 2 (For Fuel Pump) 20A.

**NOTE:**  
 USE COMPRESSION RECORDER  
 WITH RUBBER CONE AND  
 MEASURING RANGE TO 1750 kPa  
 (17,5 BAR/253,75 PSI).  
 ENGINE AT OPERATING  
 TEMPERATURE (OIL  
 TEMPERATURE  $\geq 80^{\circ}\text{C}/176^{\circ}\text{F}$ )

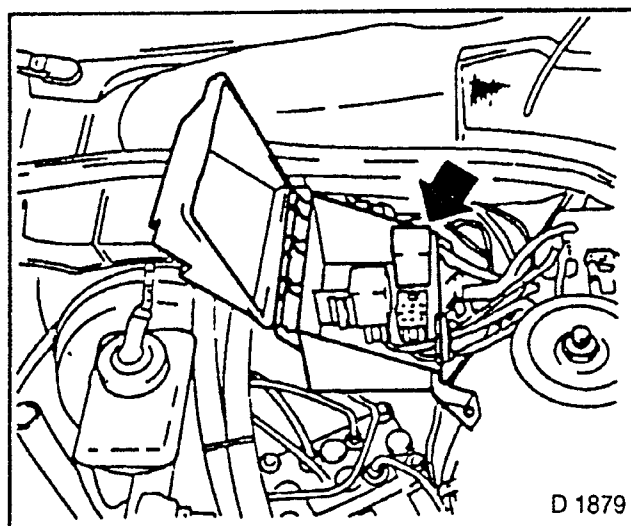


Fig. 360

### INSPECT

1. Compression.
2. Actuate starter approximately four seconds with fully opened throttle valve — minimum engine speed approximately 300 rpm.
3. Permissible pressure deviation of individual cylinders approximately 100 kPa (1 bar/17,5 psi).

### TIGHTEN (TORQUE)

1. Spark plug on cylinder head — 25 Nm. Use KM-194.

### INSTALL, CONNECT

1. Spark plug connection.
2. Ignition cable cover to cylinder head cover.
3. Terminal "15" to ignition coil.
4. Fuel pump relay.

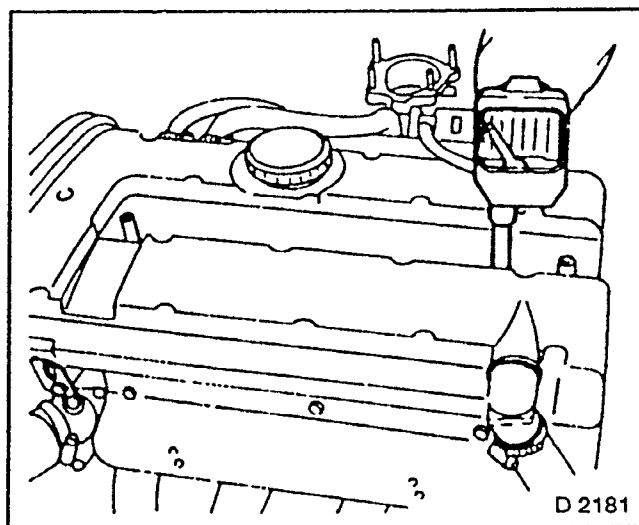


Fig. 361

## Engine Pressure Loss — Check

Engine at operating temperature (oil temperature  $\geq 80^{\circ}\text{C}/176^{\circ}\text{F}$ ).

### REMOVE, DISCONNECT

1. Pre-volume chamber.
2. Air intake hose.
3. Ignition cable cover from cylinder head cover.
4. All spark plugs — KM-194.
5. Spark plug connection — KM-717.
6. Coolant compensation tank cover.
7. Oil filler cover.
8. Oil dipstick.
9. V-belt for alternator.
10. Front toothed belt cover.

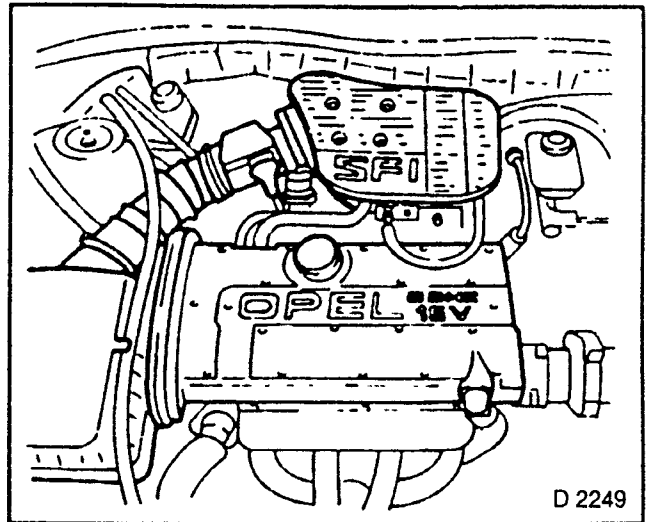


Fig. 362

### REMOVE, DISCONNECT

#### C 20 LET:

1. Throttle manifold cover (1).
2. Ignition cable cover from cylinder head cover (2).
3. All spark plugs — KM-194.
4. Spark plug connectors — KM-717.
5. Coolant compensation tank closure cap.
6. Oil filler aperture closure cap.
7. Oil dipstick.
8. V-belt for alternator.
9. Front toothed belt cover.

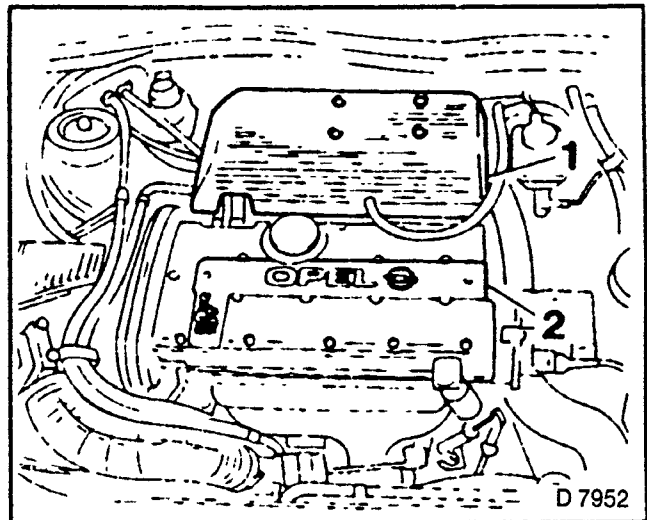


Fig. 363

### INSTALL, CONNECT

1. Connecting piece into spark plug bore of 1st cylinder.
2. Compression loss tester onto compressed air system.
3. Connecting hose onto connecting piece (observe manufacturer's instructions).

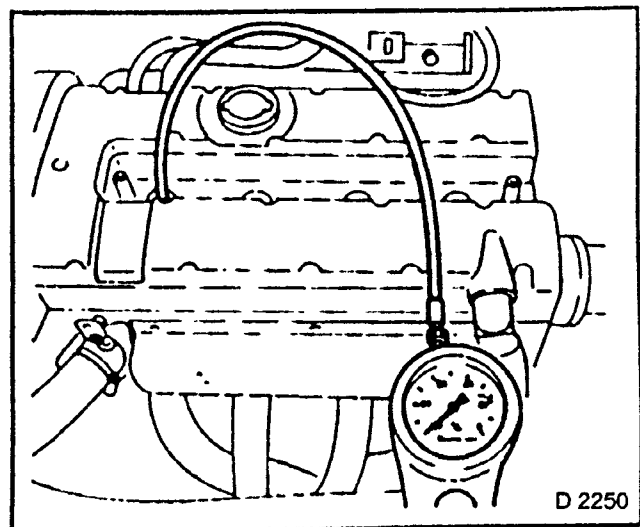


Fig. 364



4. Piston of 1st cylinder onto ignition TDC position — markings. For this, attach MKM-604-21 (Torx Nut E 20) to fastening bolts for toothed belt drive gear and position crankshaft pulley in rotational direction of engine on marking.
5. Simultaneously, markings of camshaft sprockets and cylinder head cover must align.

**NOTE:**  
**TURN CRANKSHAFT PULLEY**  
**SLOWLY AND REGULARLY.**

### INSPECT

1. Compression loss — crankshaft must not turn.
2. Permitted total compression loss per cylinder approximately 25%.
3. Permitted compression deviation of individual cylinder approximately 10%.
4. Air flow to:
  - intake manifold
  - exhaust
  - compensation tank
  - crankcase.

### INSPECT

1. Compression loss analogously with 3rd, 4th and 2nd cylinders.
2. Piston of cylinder to be checked in ignition TDC position.
3. Ignition sequence: 1 — 3 — 4 — 2.
4. Ascertain ignition TDC position by positioning marks on camshaft sprocket.
5. Turn crankshaft a further 180° in engine rotational direction (corresponds to 90° on camshaft) using MKM-604-21 (Torx Nut E 20) (markings on camshaft sprocket and cylinder head cover align).
6. Determine ignition TDC position for 4th and 2nd cylinders similarly.

**WARNING:**  
**TURN CRANKSHAFT PULLEY**  
**SLOWLY AND REGULARLY.**

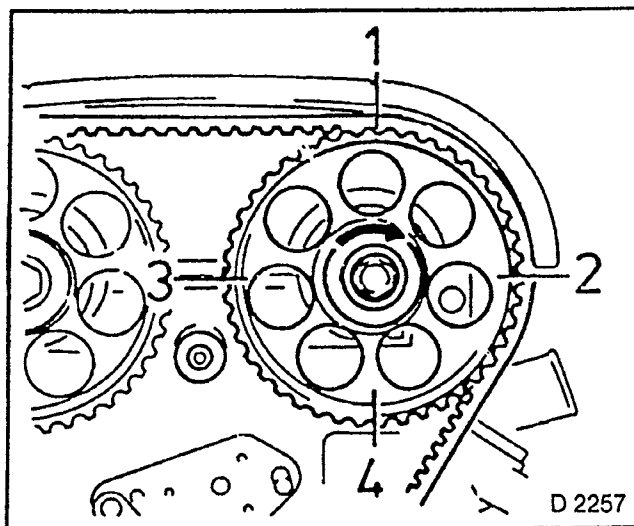


Fig. 365

### INSTALL, CONNECT 2,0 XE

1. Spark plugs — 20 Nm.  
Use KM-194.
2. Front toothed belt cover.
3. Place on V-belt and tension.
4. Oil filler aperture cover.
5. Oil dipstick.
6. Coolant compensation tank cover.
7. Ignition cable cover from cylinder head cover.
8. Pre-volume chamber.
9. Air intake hose.

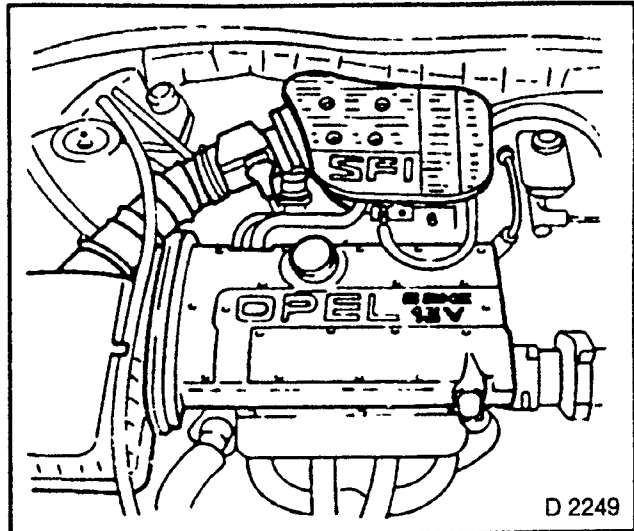


Fig. 366

### INSTALL, CONNECT

#### C 20 LET

1. Spark plugs — 25 Nm.
2. Use KM-194.
3. Front toothed belt cover.
4. Place on V-belt and tension.
5. Oil filler aperture cover.
6. Oil dipstick.
7. Coolant compensation tank cover.
8. Ignition cable cover from cylinder head cover.
9. Cover to throttle manifold — 5 Nm.

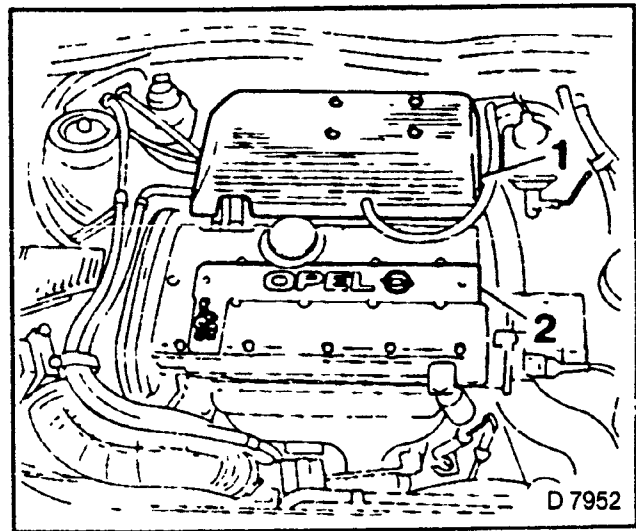


Fig. 367

## Engine Oil Temperature — Measure

### MEASURE

1. Engine oil temperature — MKM-596
2. Insert measuring probe into dipstick guide pipe to approximately 1 cm above oil pan floor.
3. Seal guide pipe opening with enclosed rubber plug (observe manufacturer's instructions).

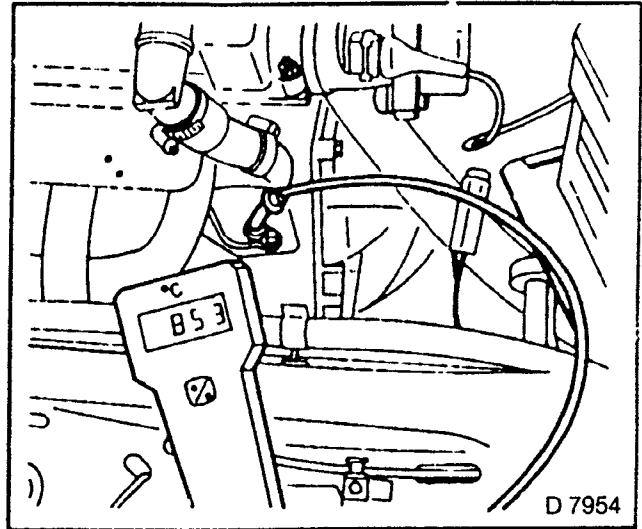


Fig 368

## Engine Oil Pressure — Check

### REMOVE, DISCONNECT

1. Oil pressure switch.

### INSPECT

1. Oil pressure — KM-498-B and KM-135.
2. Oil pressure minimum 0,3 bar/5,25 psi at idle speed and oil temperature  $\geq 80^{\circ}\text{C}/176^{\circ}\text{F}$ .

### INSTALL, CONNECT

1. Oil pressure switch.

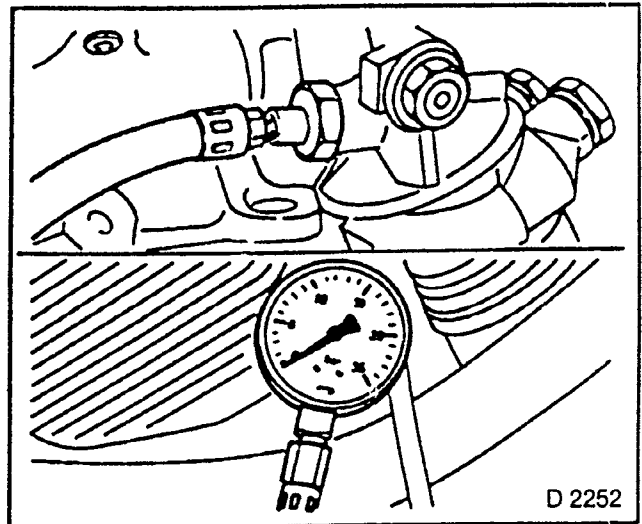


Fig. 369

# ENGINE OIL CONSUMPTION — MEASURE

## GENERAL

The term “oil consumption” of an internal combustion engine refers to the amount of oil which is used as a consequence of combustion. Oil consumption should under no circumstances be confused with oil loss caused by leaks in the oil pan, cylinder head cover, etc.

The task of the engine oil is to:

1. Separate surfaces that slide on one another with an oil film, i.e. prevent dry friction.
2. Conduct the heat produced by friction away.
3. Conduct combustion residue away.

These tasks make necessary the consumption of a certain amount of oil, i.e. the expectations of many who claim that further development of the internal combustion engine will lead to an engine that does not require oil are absolutely nonsensical.

The oil consumption is however influenced by external operating factors, driving style and manufacturing tolerances. Under normal circumstances, the consumption is so minimal that only a small amount need be topped up between the prescribed oil change intervals, or even no topping up at all.

Topping up is however absolutely necessary if the oil level sinks below the “MIN” mark on the dipstick. Likewise, ensure that the oil level does not exceed the upper “MAX” mark on the dipstick, which leads to increased oil consumption.

As oil consumption is a technical necessity, indications that an engine is not consuming oil means that we can conclude that the oil is being diluted by special operating conditions.

Frequent cold starts, driving when over-cold, etc. result in the oil flowing back to the oil pan containing fuel particles and condensation, and thus becoming “diluted”; this can lead to the incorrect supposition that the engine is not consuming any oil at all.

Oil diluted in this fashion lacks lubricating power and may lead to engine damage if the prescribed oil change intervals are not observed. The main causes for oil dilution are driving in mainly urban traffic and frequent driving at too low engine speeds when the engine is cold.

The oil consumption first begins to stabilize after operating for a few thousand kilometers; therefore, measurements of the oil consumption only become realistic after about 7 500 km. Before measuring the oil consumption, ensure that the engine is not losing oil due to a leak.

## NOTES:

The oil dipstick can only be used for checking and not for measurement.

The engine must always be switched off for at least 2 minutes before the oil level can be checked.

If, after an oil change, the maximum engine oil filling does not match the maximum level mark on the dipstick, this can be attributed to manufacturing tolerances.

All information regarding the permissible engine oil consumption and filling quantities are included in the Owner's & Driver's Manual.

## MEASURING METHOD

1. The check is carried out with the vehicle on a horizontal surface with the engine at operating temperature (engine oil temperature  $\geq 80^{\circ}\text{C}/176^{\circ}\text{F}$ ).
2. Allow engine to run at idle speed immediately before draining the engine oil.
3. Drain engine oil immediately after switching off engine and record the time with a stopwatch — draining time: 3 minutes. (Experiments have indicated that the draining should be kept within 3 minutes).

Always allow the engine oil to drain until the stream of oil turns into drops.

4. Allow the drained engine oil to cool down to approximately  $20^{\circ}\text{C}/68^{\circ}\text{F}$  (1 to 2 hours).
5. The amount of cooled oil determined in a measuring cylinder\* and fresh oil is added up to the maximum engine oil filling quantity, minus 0,25 litres for the unchanged engine oil filter.
6. Using this amount of engine oil, the customer should travel at least 500 km without changing the engine oil. (The driver should keep to his/her normal routes and driving style).
7. The procedure described above (points 1 to 4) is then repeated with exactly the same time for draining.
8. The amount of engine oil “missing” from the measuring cylinder is the engine oil consumption/distance covered.

\* Commercially available measuring cylinder (transparent) with a capacity of 1 to 2 litres.

## Timing — Check and Adjust

### REMOVE, DISCONNECT

1. Drive belt for alternator.
2. Front toothed belt cover.

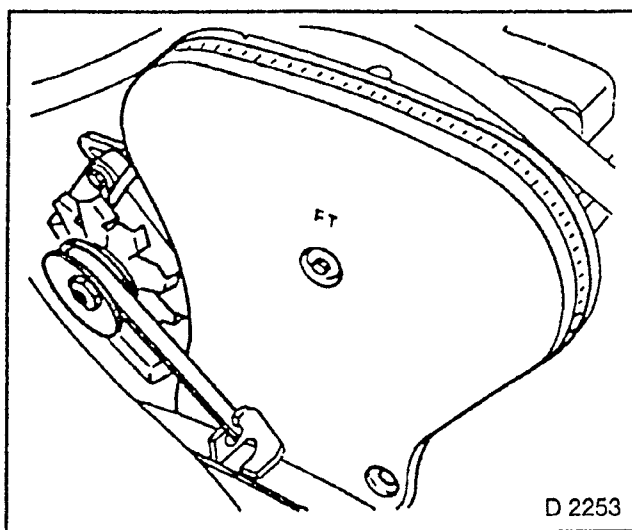


Fig. 370

### INSPECT

#### TIMING

Place MKM-604-21 (Torx Nut E 20) on fastening bolt for toothed belt drive gear and position crankshaft pulley in rotational direction of engine on marking. Simultaneously, markings on camshaft gear and cylinder head cover must align.

#### NOTE:

Turn crankshaft pulley slowly and regularly.

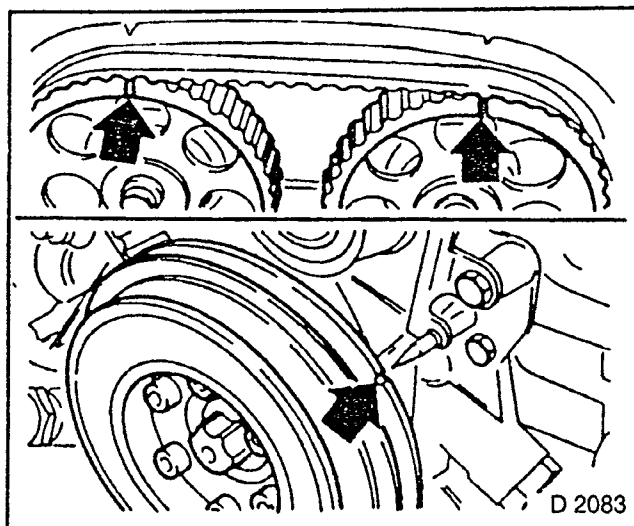


Fig. 371

### ADJUST

1. Timing.
2. Loosen tension roller.
3. Remove toothed belt.
4. Place camshaft sprockets (short distance) on marking.

**WARNING:**  
ADJUSTMENT OF THE TENSION OF A USED TOOTHED BELT IS NOT PERMISSIBLE.

ALWAYS INSTALL A NEW TOOTHED BELT DURING OPERATIONS WHICH INVOLVE THE REMOVAL OF THE TOOTHED BELT.

SEE OPERATION "TOOTHED BELT, REPLACE" PAGE 168.

### INSTALL, CONNECT

1. Front toothed belt cover.
2. Install V-belt and tension.

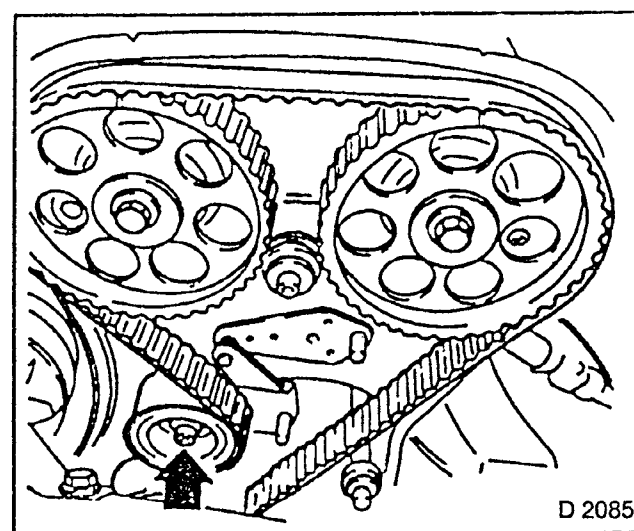
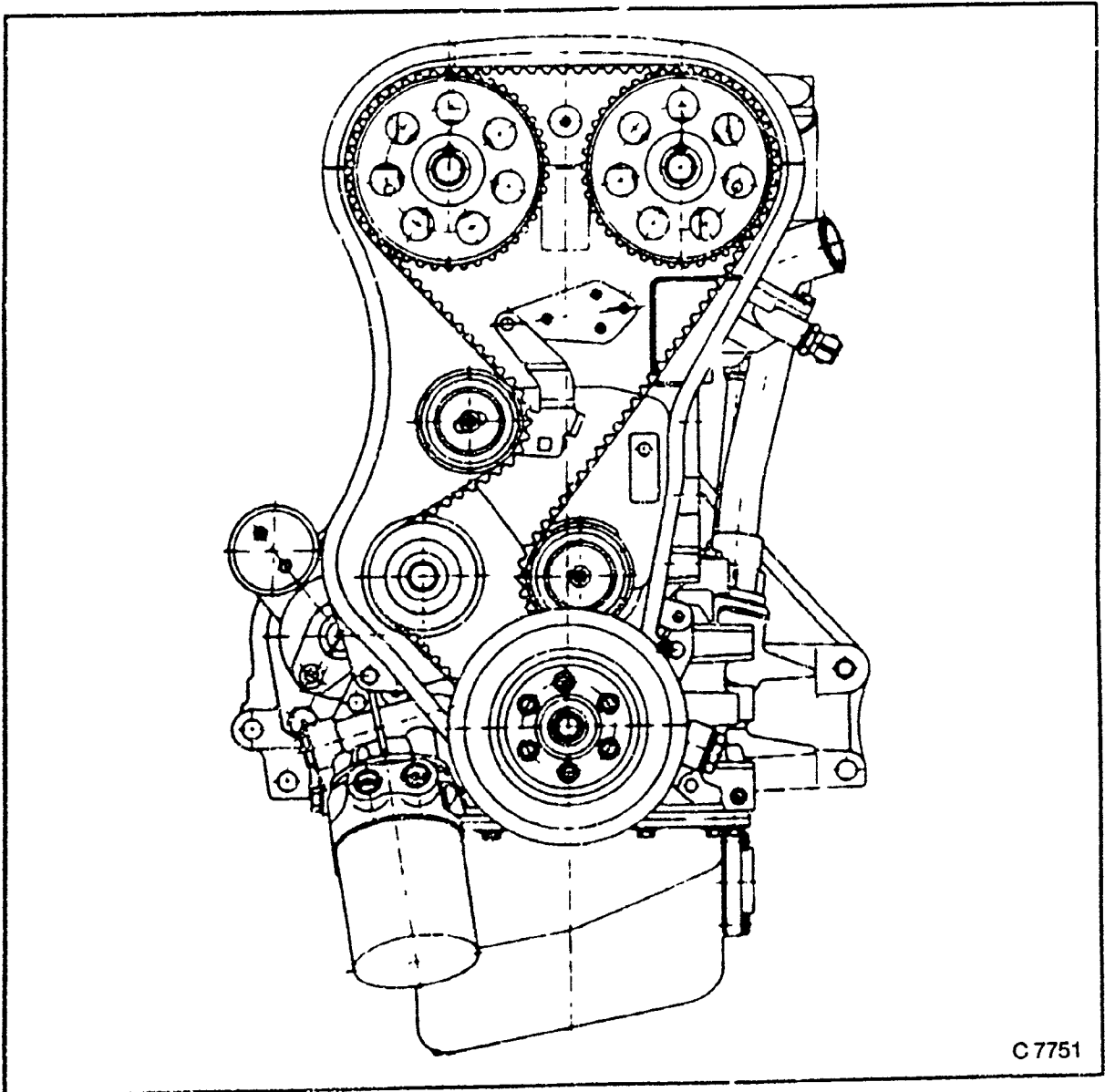


Fig. 372

### C 20 LET:

In addition, air cleaner housing.

# Engine Timing Side — Air Cleaner Housing



C 7751

Fig. 373

C 20 XE/20 LET  
Engine Timing

## RECOMMENDED TORQUE VALUES

|  | Nm                           |
|--|------------------------------|
| Crankshaft pulley to toothed belt drive pinion ..... | 20                           |
| Front toothed belt cover to cylinder head .....      | 8                            |
| Front toothed belt cover to intermediate piece ..... | 8                            |
| Front toothed belt cover to oil pump .....           | 8                            |
| Guide roller to cylinder block .....                 | 25 + 45° + 15° <sup>1)</sup> |
| Tension roller to cylinder block .....               | 25                           |
| Tension strap to alternator (M 10) .....             | 35                           |
| Tension strap to alternator (M 8) .....              | 25                           |

<sup>1)</sup> Use new bolts

## Toothed Belt — Replace

### REMOVE, DISCONNECT

1. Ground cable from battery.
  2. Air intake hose.
  3. Engine compartment cover.
  4. Air cleaner housing.
- Fig. 374 shows C 20 XE engine.

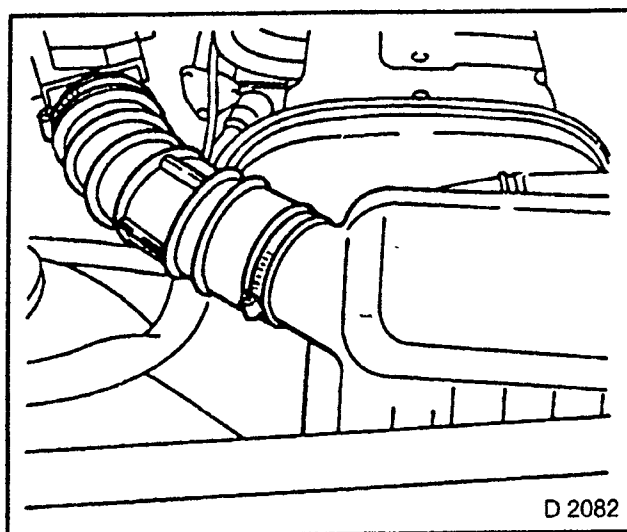


Fig. 374

### REMOVE, DISCONNECT

1. Drive belt for alternator.
2. Power steering pump.
3. If present: drive belt for air-conditioning compressor.

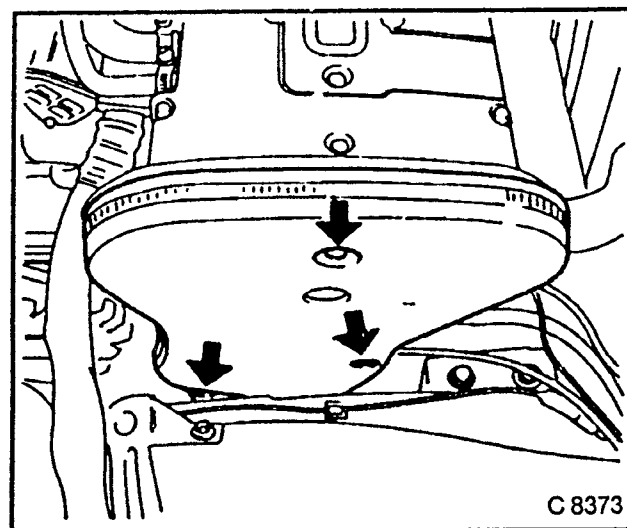


Fig. 375

### REMOVE, DISCONNECT

1. Front toothed belt cover.
2. Piston of 1st cylinder in ignition TDC position — markings.  
For this, attach MKM-604-21 (Torx Nut E 20) to fastening bolt of toothed belt drive gear.

**NOTE:**  
**TURN CRANKSHAFT SLOWLY AND REGULARLY.**

**REMOVE, DISCONNECT**

1. Crankshaft pulley with Splined Wrench KM-321-A.  
For this, attach MKM-604-21 (Torx Nut E 20) to fastening bolt of toothed belt drive gear and counterhold.

**NOTE:**  
**BEFORE REMOVING CRANKSHAFT PULLEY, CHECK POSITION OF MARKINGS (CRACKSHAFT PULLEY AND CAMSHAFT SPROCKETS).**

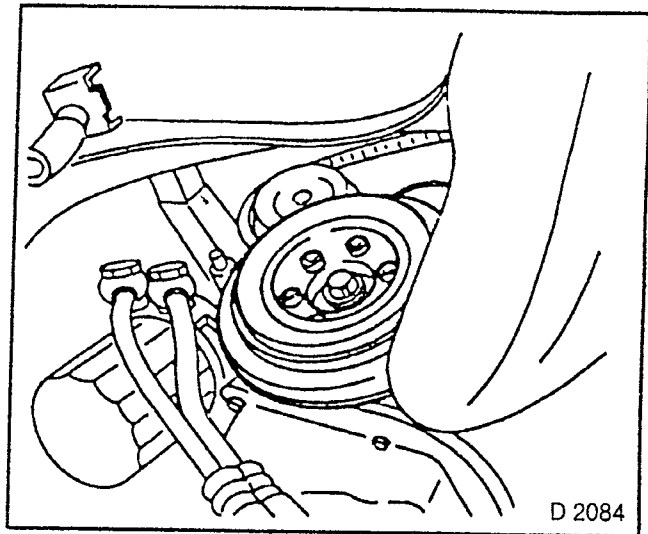


Fig. 376

2. Loosen tension roller and remove toothed belt.

**WARNING:**  
**DO NOT TURN CRANKSHAFT OR CAMSHAFT WITH LOOSENED TENSION ROLLER — TOOTHED BELT MAY SPRING OVER.**

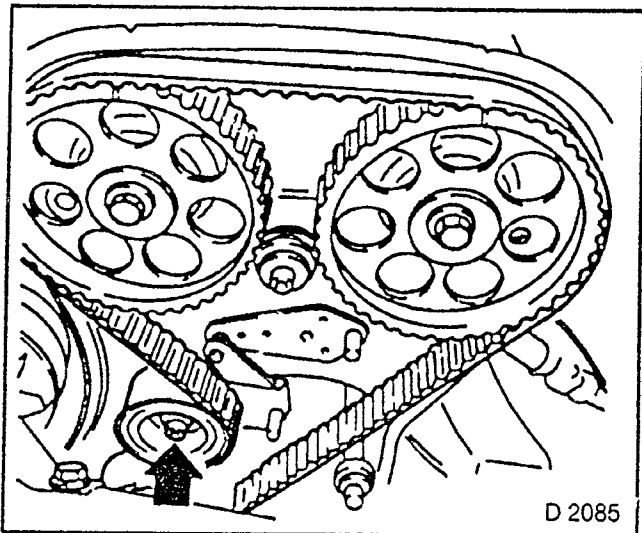


Fig. 377

**INSTALL NEW TOOTHED BELT — DRIVING SIDE TAUT****INSTALL, CONNECT**

1. Crankshaft pulley with Splined Wrench KM-321-A.  
For this, attach MKM-604-21 (Torx Nut E 20) to fastening bolt of toothed belt drive gear and counterhold.

**TIGHTEN (TORQUE)**

1. Crankshaft pulley to toothed belt drive gear — 20 Nm.

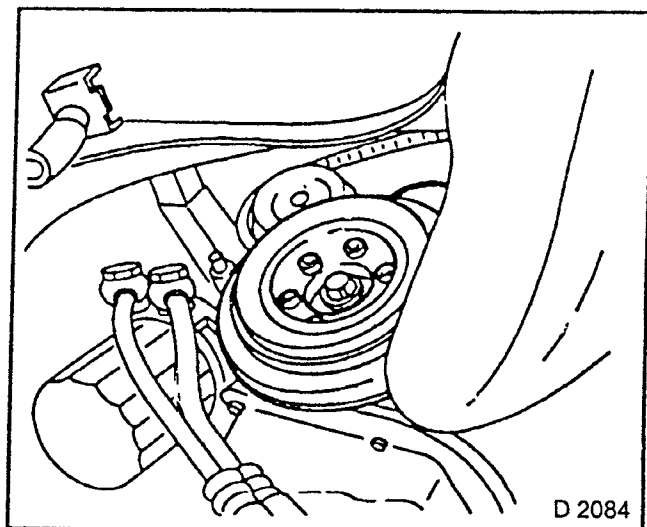


Fig. 378



**ADJUST**

1. Toothed belt tension.

**NOTE:**  
**ADJUSTMENT IS CARRIED OUT**  
**WITH COLD ENGINE — ROOM**  
**TEMPERATURE.**  
**ATTACH ADJUSTER KM-666 —**  
**FASTENING BOLT (1) LOOSENED.**

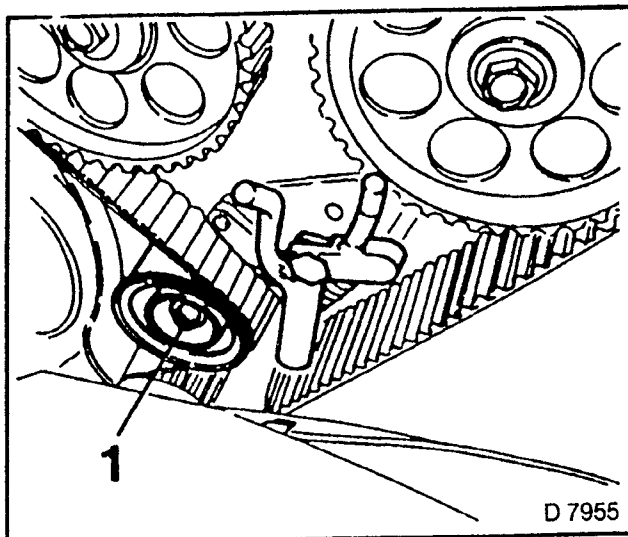


Fig. 379

2. Counter-clockwise — seen from TDC — mark 8th tooth of camshaft sprocket.

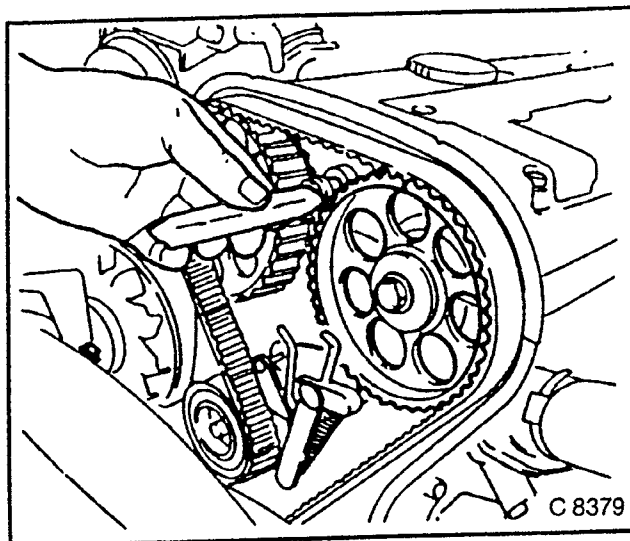


Fig. 380

3. Attach MKM-604-21 (Torx nut E 20) to fastening bolt (1) of toothed belt drive gear.
4. Turn crankshaft two revolutions and eight-teeth (camshaft pulley) in engine rotational direction (2) — mark (3) aligns with notch (4) on cylinder head cover.

**WARNING:**  
**TURN CRANKSHAFT UNIFORMLY**  
**AND WITHOUT JERKING —**  
**TOOTHED BELT MAY JUMP.**

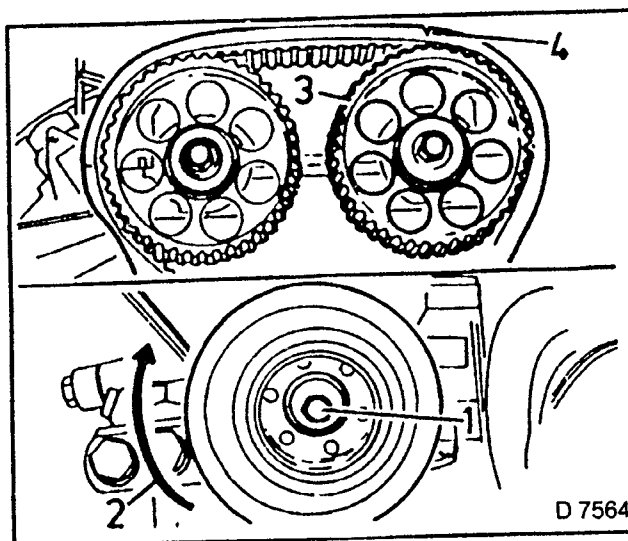


Fig. 381

## TORQUE — ANGLE METHOD

1. Tension roller to cylinder block —  
25 Nm. 45° + 15°.
2. Use new bolt.
3. Remove Adjuster KM-666.
4. Turn camshaft sprockets further to TDC marking.  
(Notch of crankshaft pulley must then match pointer — arrow.)

## INSTALL, CONNECT

1. Front toothed belt cover — 8 Nm.

### NOTE:

**ENSURE FIRM SEATING OF RUBBER GROMMETS ON FASTENING PIN.**

## INSTALL, CONNECT

1. Drive belt for power steering pump.
  2. Drive belt for air-conditioning compressor — if present.
- See Sections M and D.

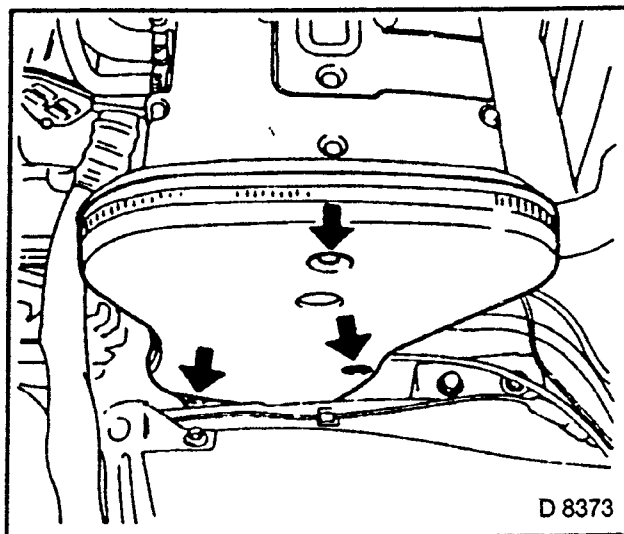


Fig. 382

## Toothed Belt Tension Roller — Replace

### REMOVE, DISCONNECT

1. Toothed belt — see operation "Toothed Belt, Replace", page 184.  
Tension roller (A) with tension roller carrier plate (B).
2. Spacing sleeve.

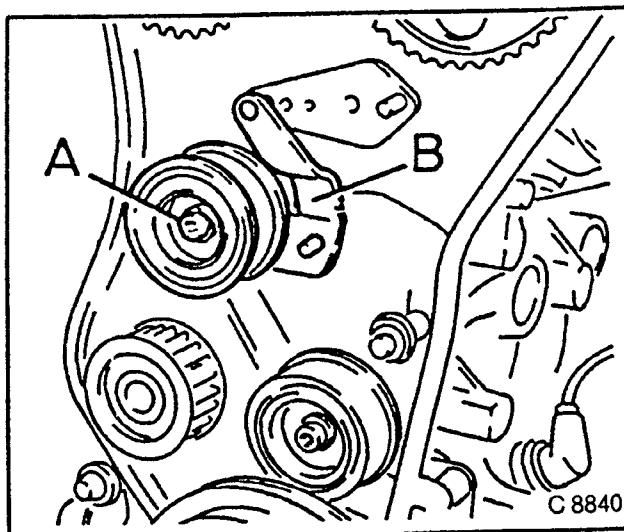


Fig. 383

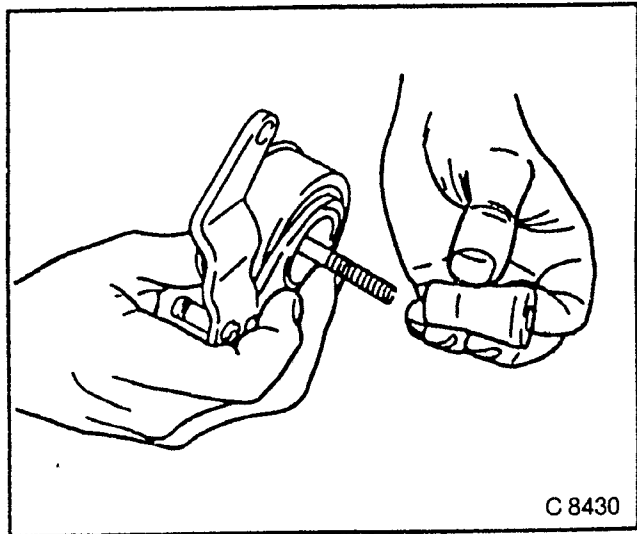
## INSTALL, CONNECT

1. Tension roller with tension roller carrier plate.
2. Spacing sleeve.

**NOTE:**  
**WHEN INSTALLING SPACING SLEEVE, ENSURE THAT THE SMALLER DIAMETER POINTS TOWARDS THE ROLLER CARRIER PLATE.**

## TORQUE — ANGLE METHOD

1. Tension roller to cylinder block — 25 Nm. 45° + 15°. Use new bolt.
2. Install new toothed belt. See operation "Toothed Belt, Replace", page 184.



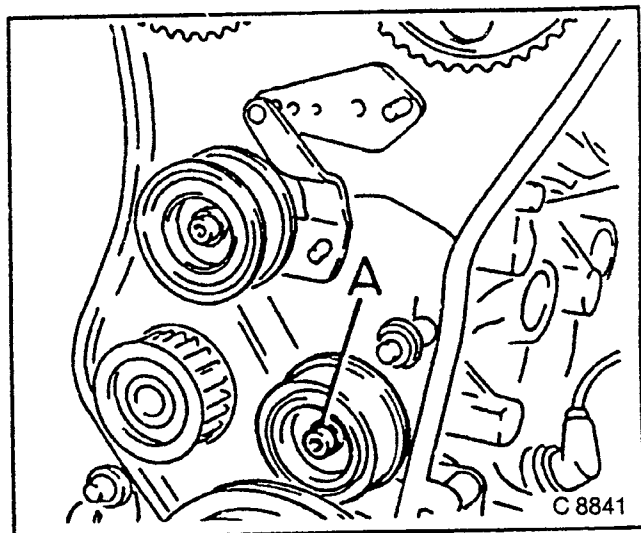
C 8430

Fig. 384

## Toothed Belt Guide Roller — Replace

### REMOVE, DISCONNECT

1. Toothed belt — see operation "Toothed Belt, Replace", page 184.
2. Guide roller (A) with spacing sleeve.



C 8841

Fig. 385

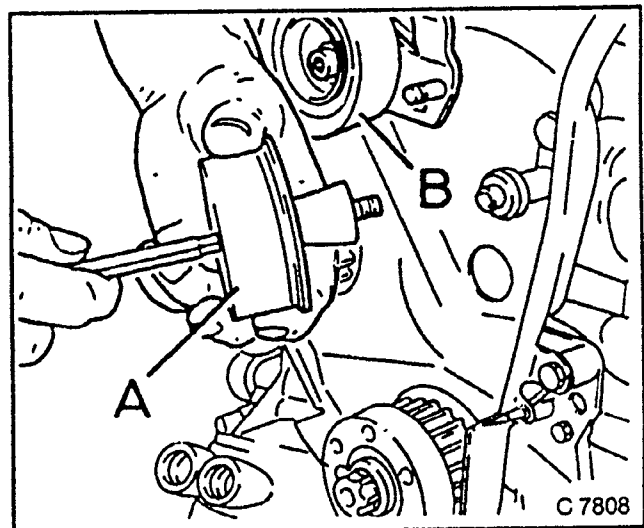
### INSTALL, CONNECT

1. Guide roller (A) with spacing sleeve.

**NOTE:**  
**WHEN INSTALLING SPACING SLEEVE, ENSURE THAT THE SMALLER DIAMETER POINTS TOWARDS THE ROLLER CARRIER PLATE.**

### TIGHTEN (TORQUE)

1. Guide roller to cylinder block — 25 Nm. Use new bolt.
2. Install new toothed belt. See operation "Toothed Belt, Replace", page 184.



C 7808

Fig. 386

## Air Cleaner Housing — Remove and Install (C 20 LET)

### REMOVE, DISCONNECT

1. Wiring plug (1).
2. Bracket (2).
3. Intake hose (3).
4. Upper part of housing (two clamps, two bolts).
5. Cleaner element.
6. Lower part of housing (three bolts) upwards.

### INSTALL, CONNECT

1. Lower part of housing — ensure that sleeve is correctly seated.
2. Cleaner element.
3. Upper part of housing.
4. Intake hose.
5. Bracket.
6. Wiring plug.

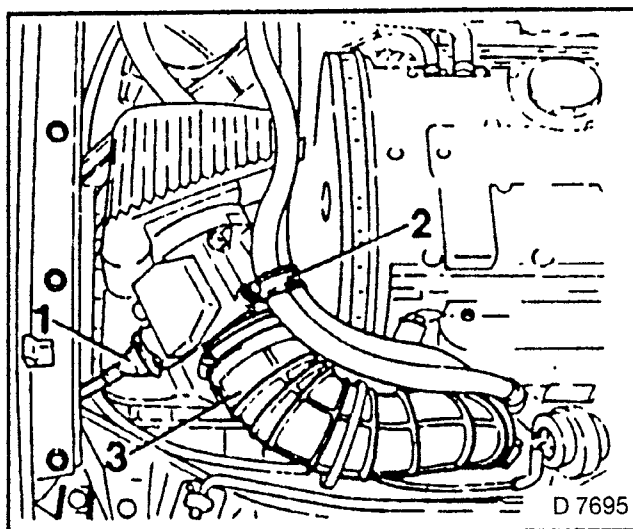


Fig. 387

## Cylinder Head

### Recommended Torque Values

|  | Nm                                 |
|--|------------------------------------|
| Alternator tension strap to intake manifold .....                                | 25                                 |
| Camshaft bearing cover to cylinder head (M 8) .....                              | 20                                 |
| Camshaft sprocket to camshaft .....  | 50 + 60° + 15° <sup>1)</sup>       |
| Cylinder head cover to cylinder head .....                                       | 8                                  |
| Cylinder head to cylinder block .....  | 25 + 65° + 65° + 65° <sup>2)</sup> |
| Ignition cable cover to cylinder head cover .....                                | 8                                  |
| Intake manifold to cylinder head .....   | 22                                 |
| Rear camshaft bearing cover to cylinder head (M 6) .....                         | 10                                 |
| Rear toothed belt cover to cylinder head .....                                   | 6                                  |
| Spark plug to cylinder head .....  | 25                                 |
| Thermostat housing to cylinder head .....  | 15                                 |
| Brake servo vacuum line to intake manifold .....                                 | 15                                 |
| Clamping bracket, alternator to intake manifold .....                            | 25                                 |
| Cover plate to cylinder head (M 6 bolt) .....                                    | 9                                  |
| Cover to throttle valve manifold .....   | 5 <sup>1)</sup>                    |
| Fastening bolt to bracket .....  | 20°                                |
| Fastening bolts to exhaust joint .....   | 12 <sup>3)</sup>                   |
| Front toothed belt cover to cylinder head, intermediate piece and oil pump ..... | 8                                  |
| Performance header with cover plate to cylinder head .....                       | 22                                 |

<sup>1)</sup> C 20 LET only.

<sup>2)</sup> Use new nuts.

<sup>3)</sup> Use new bolt(s)

<sup>4)</sup> After test run, turn a further 30° to 45°.

## Camshaft Seal Ring — Replace

### REMOVE, DISCONNECT

1. Toothed belt — see operation "Toothed Belt, Replace", page 184.
2. Camshaft sprockets.
3. Seal ring — make hole in middle of ring (arrow), turn in self-tapping screw and edge out.

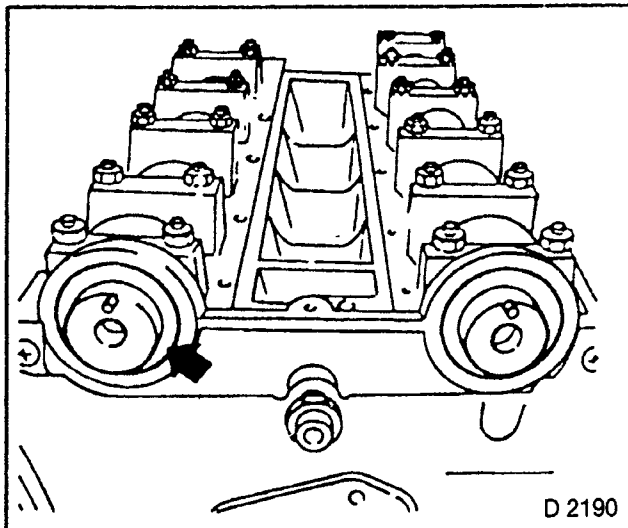


Fig. 388

### CLEAN

Sealing surfaces

### INSTALL, CONNECT

1. Seal ring with KM-422 — use bolt and washer of camshaft sprocket.
2. Coat sealing lip of seal rings with protective grease.
3. Toothed belt.
4. Camshaft sprockets.

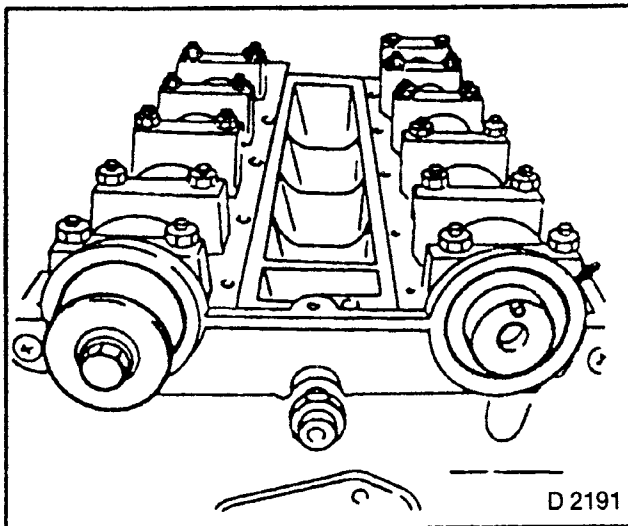


Fig. 389

## Gasket — Intake Manifold/Cylinder Head — Replace (C 20 LET)

### REMOVE, DISCONNECT

1. Ground cable from battery.
2. Throttle valve manifold cover.
3. Alternator.

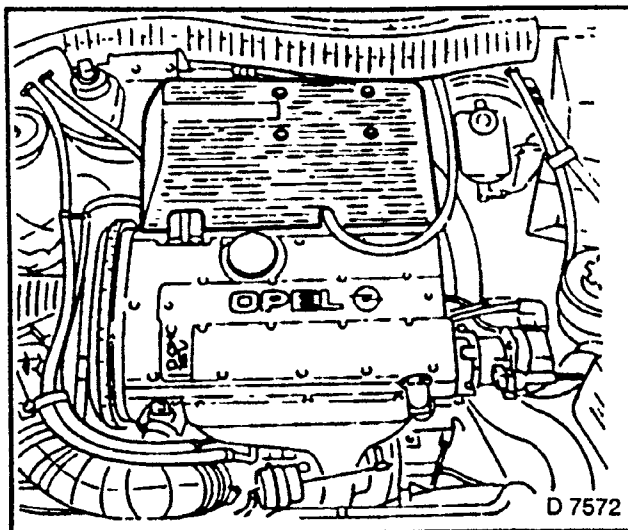


Fig. 390

**REMOVE, DISCONNECT**

1. Coolant hose (1) from compensation tank.
2. Coolant hose (2) from intake manifold.
3. Collect coolant.

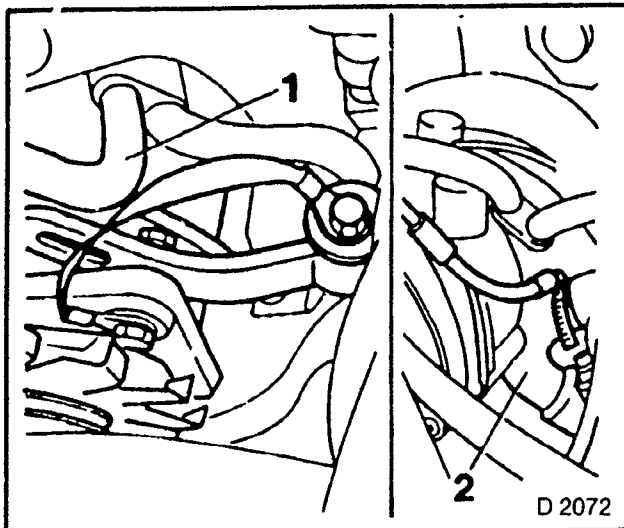


Fig. 391

**REMOVE, DISCONNECT**

1. Air hose (1) from throttle valve manifold.

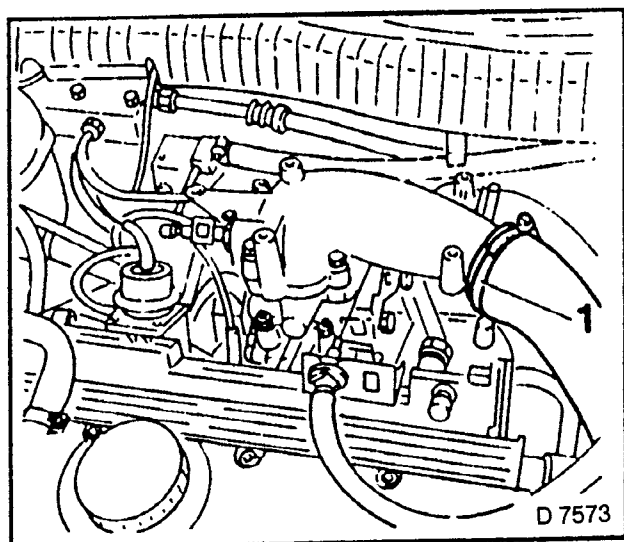


Fig. 392

**REMOVE, DISCONNECT**

1. Brake servo vacuum line (arrow) from intake manifold.
2. Intake manifold/cylinder block support from intake manifold.
3. Loosen lower fastening bolt.
4. Swing support aside.

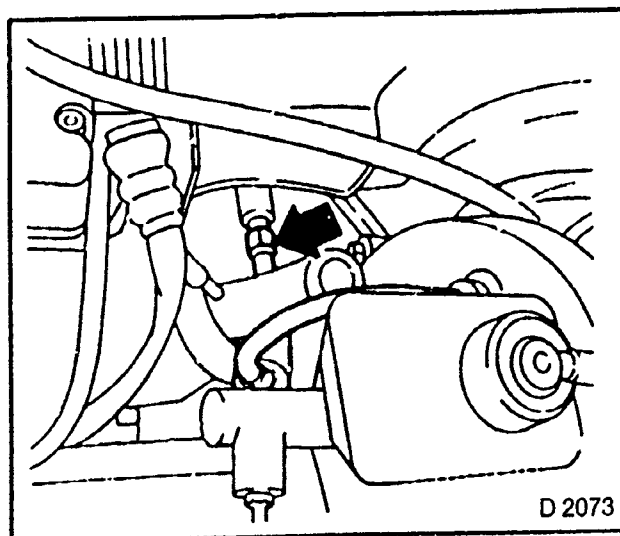


Fig. 393

**REMOVE, DISCONNECT**

1. Bowden cable.
2. Fuel lines — close off with spring clamps.
3. Engine vent hoses from cylinder head cover.

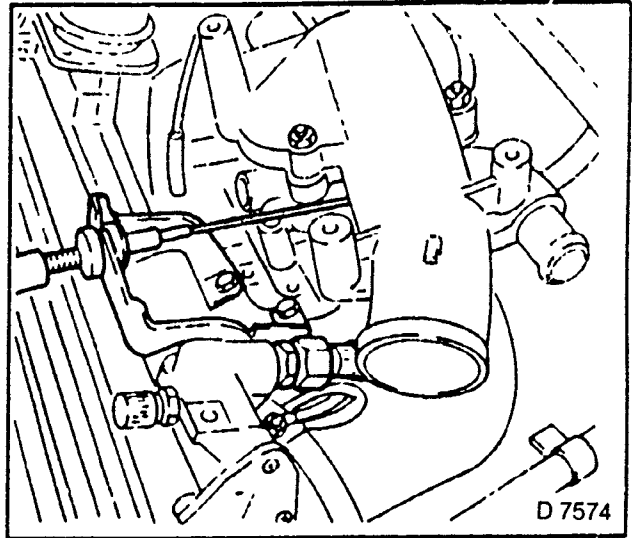


Fig. 394

**REMOVE, DISCONNECT**

1. Plug strip from injection valves — For this, pull back retaining clamp of 1st cylinder injection valve.
2. Wiring plug (1) for hot start valve.
3. Wiring plug (2) for intake air temperature sensor.
4. Wiring plug (3) for throttle valve potentiometer.
5. Wiring plug (4) for tank vent valve.
6. Ground connections from fuel distributor pipe.
7. Note routing of lines.

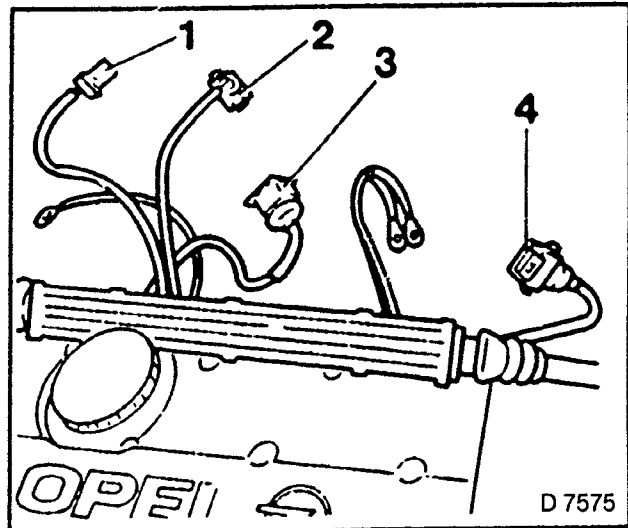


Fig. 395

**REMOVE, DISCONNECT**

1. Wiring plug from idle speed adjuster.
2. Lay plug strip for injection valves aside at front.

**REMOVE, DISCONNECT**

1. Vacuum hose (1) from throttle valve housing.
2. Vacuum hose (2) from branch piece.

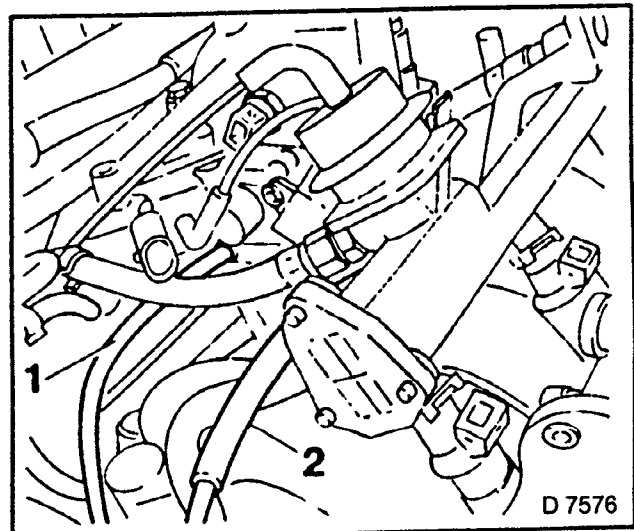


Fig. 396

**REMOVE, DISCONNECT**

1. Fastening nuts from intake manifold.
2. Vacuum line (1) from tank vent valve.
3. Tank vent valve.
4. Intake manifold from cylinder head.

**CLEAN**

1. Sealing surfaces.

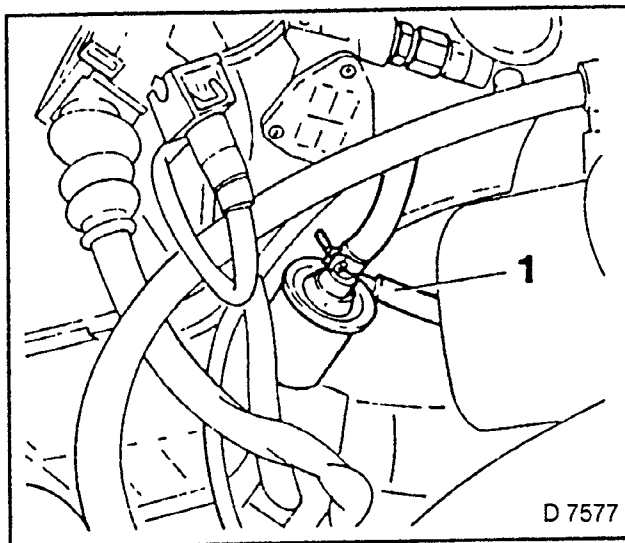


Fig. 397

**INSTALL, CONNECT**

1. Intake manifold with new gasket to cylinder head.
2. Tank vent valve.
3. Vacuum line to tank vent valve.

**TIGHTEN (TORQUE)**

1. Intake manifold to cylinder head — 22 Nm.

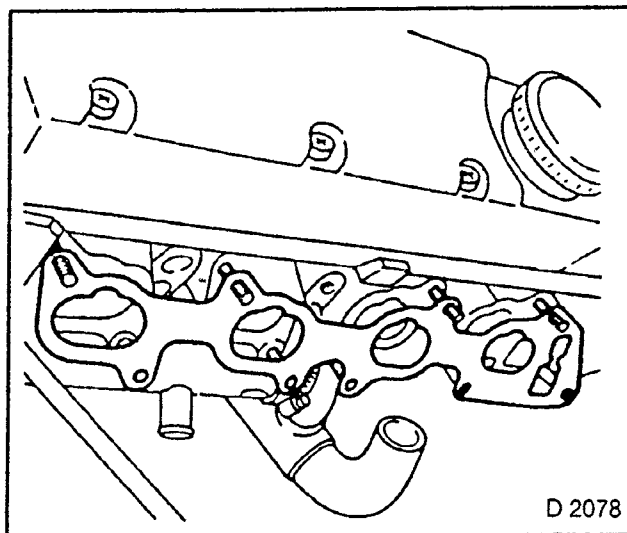


Fig. 398

**INSTALL, CONNECT**

1. Connect plug strip to injection valves.
2. Vacuum hoses.
3. Wiring plug (1) for hot start valve.
4. Wiring plug (2) for intake air temperature sensor.
5. Wiring plug (3) for throttle valve potentiometer.
6. Wiring plug (4) for tank vent valve.
7. Wiring plug to idle speed adjuster.
8. Ground connections to fuel distributor pipe.
9. Note routing of lines.
10. Check that all ground connections are in good condition and correctly seated.

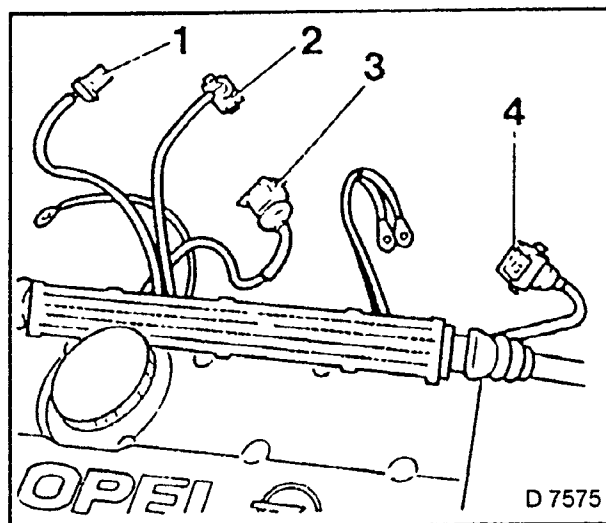


Fig. 399



**INSTALL, CONNECT**

1. Hose connections to cylinder head cover.
2. Fuel lines — remove spring clamps.
3. Bowden cable — install free of tension.

**TIGHTEN (TORQUE)**

1. Support to intake manifold and cylinder block — 25 Nm.
2. Brake servo vacuum line to intake manifold — 15 Nm.

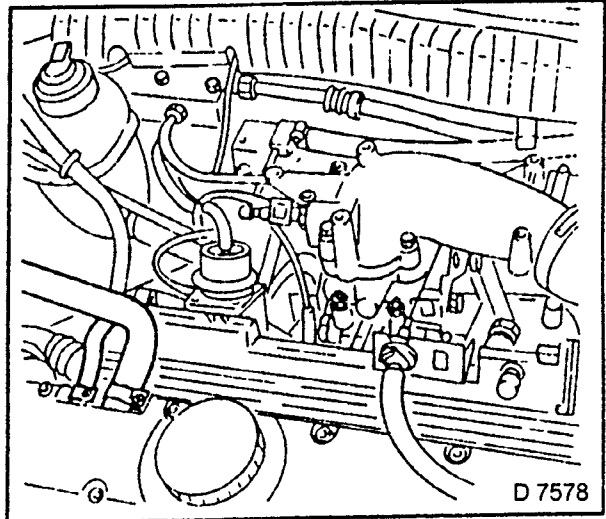


Fig. 400

**INSTALL, CONNECT**

1. Air hose to throttle valve manifold.
2. Coolant hoses to compensation tank or intake manifold.

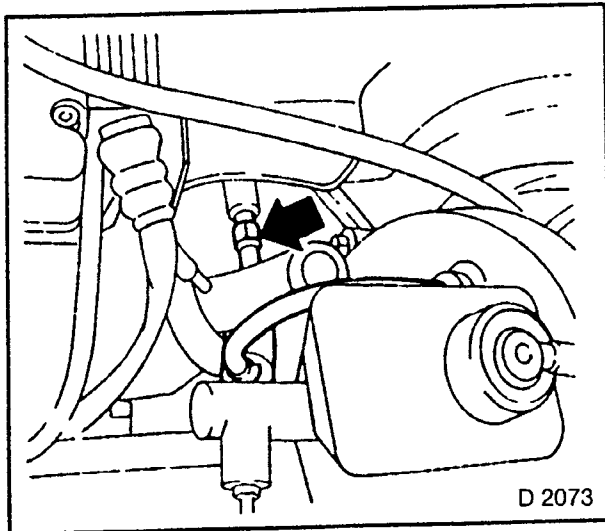


Fig. 401

**INSTALL, CONNECT**

1. Alternator.
2. Cover to throttle valve manifold — 5 Nm.
3. Ground cable to battery.
4. Top up cooling system and bleed.

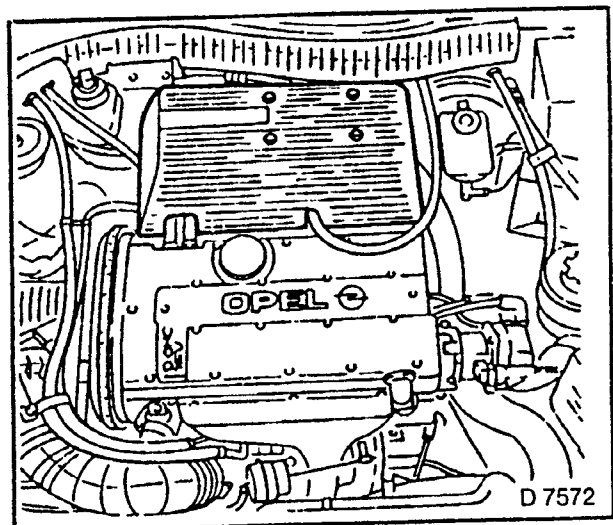


Fig. 402

## Exhaust Camshaft — Replace Inlet Camshaft — Replace

### REMOVE, DISCONNECT

1. Toothed belt — see operation “Toothed Belt, Replace”, page 184.
2. Camshaft sprockets.
3. High voltage distributor.

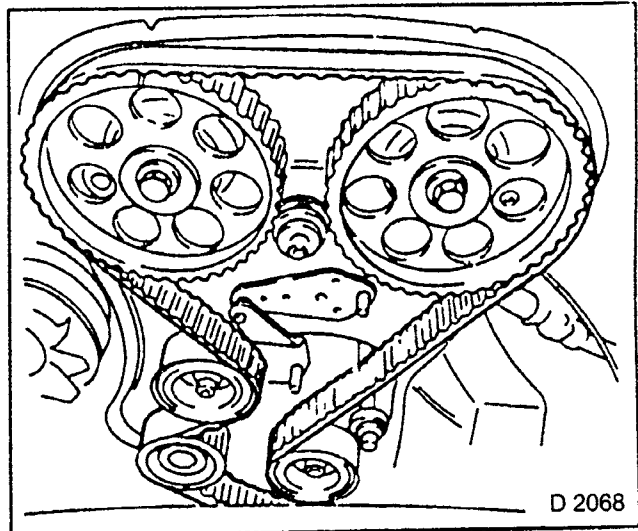


Fig. 403

### REMOVE, DISCONNECT

1. Camshaft bearing cover.
2. Loosen bolts in stages — 1/2 to full turn.

### WARNING:

**THE CAMSHAFT MUST BE EVENLY AND UNIFORMLY LOOSENED FROM THE BEARING SEAT — FRONT GUIDE BEARING.**

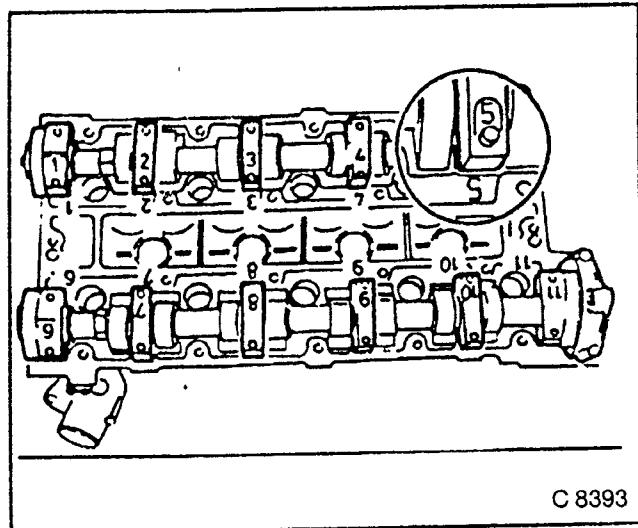


Fig. 404

### CLEAN

### INSPECT

1. Replace all components if necessary.
2. Coat sliding surfaces of valve lifter and camshaft with MoS<sub>2</sub> paste.
3. Insert camshaft.
4. Apply Sealing Compound Locktite 242 to sealing surfaces of outer camshaft bearing cover.

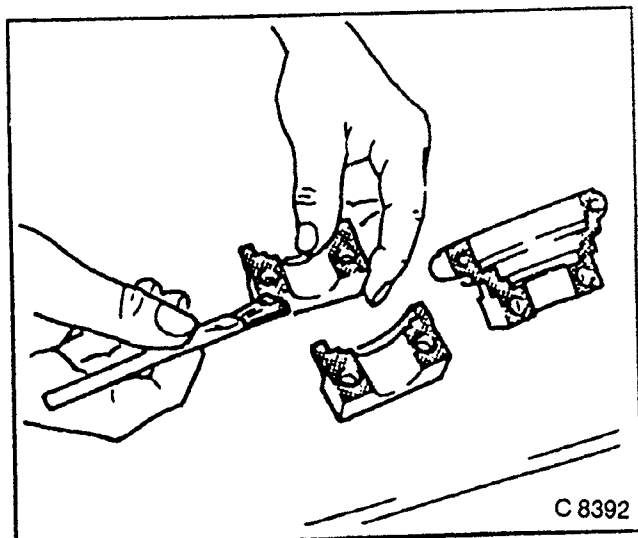
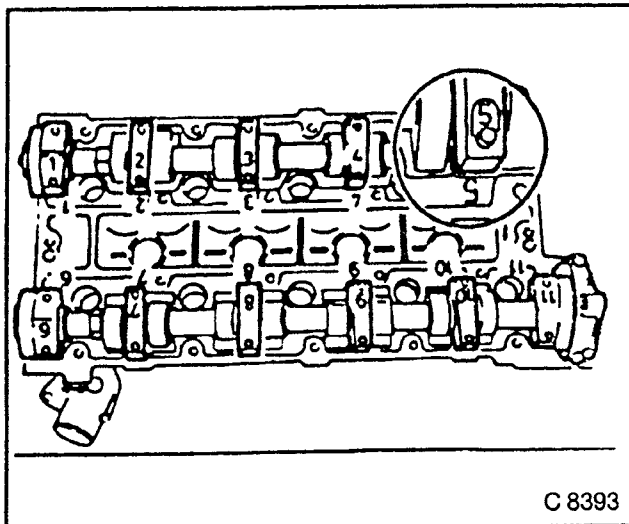


Fig 405

**INSTALL, CONNECT**

1. Camshaft bearing cover.

**WARNING:**  
IDENTIFICATION NUMBERS OF  
CAMSHAFT BEARING COVERS  
MUST MATCH THOSE IN CYLINDER  
HEAD.



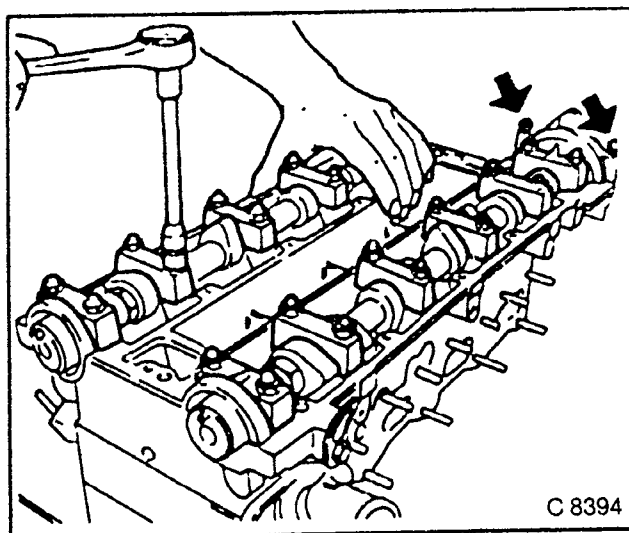
C 8393

Fig. 406

**TIGHTEN (TORQUE)**

1. Camshaft bearing cover to cylinder head (M8) — 20 Nm.
2. Rear camshaft bearing cover to cylinder head (M6) — 10 Nm.

**WARNING:**  
INSTALL CAMSHAFT COVER FROM  
INSIDE OUTWARDS. INSTALL  
FASTENING NUTS IN STAGES —  
1/2 TO FULL TURN.



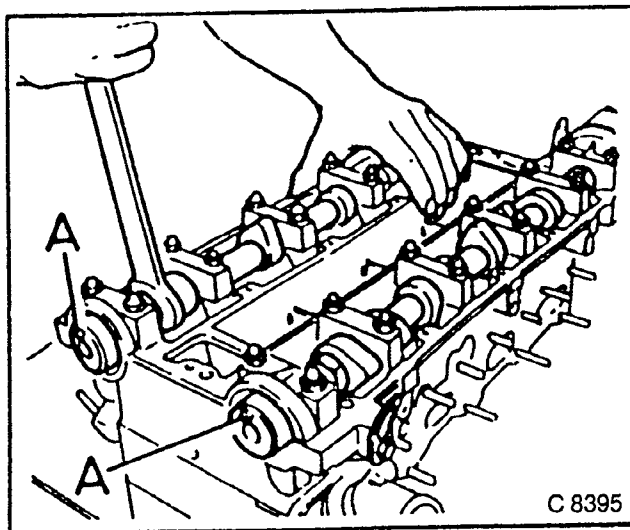
C 8394

Fig. 407

3. Turn camshaft with wrench to that pin (A) points upwards.

**INSTALL, CONNECT**

1. New camshaft seal rings with KM-422.
2. Use bolt and washer of camshaft sprocket.
3. Coat seal lips of seal ring with protective grease.
4. High voltage distributor.
5. Camshaft sprockets.
6. Toothed belt.



C 8395

Fig. 408

## Camshaft Sprockets — Remove and Install

### REMOVE, DISCONNECT

1. Toothed belt — see "Toothed Belt, Replace", page 184.
2. Ignition cable cover.
3. Spark plug connection with KM-717.
4. Hose connections (arrows) from cylinder head cover.
5. Cylinder head cover.

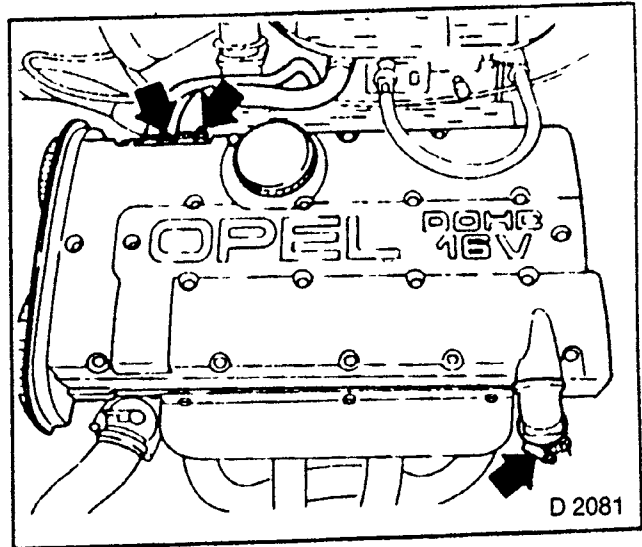


Fig. 409

### REMOVE, DISCONNECT

1. Camshaft sprockets.
2. Counterhold with wrench on hex of camshaft.

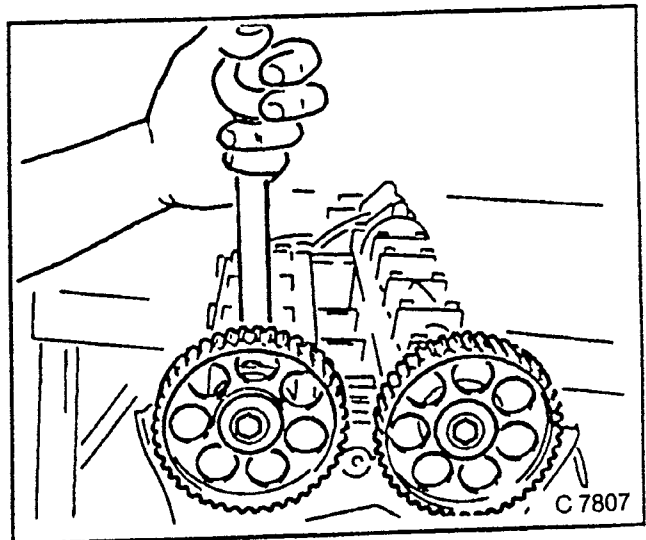


Fig. 410

### INSTALL, CONNECT

1. Camshaft sprockets with timing markings forward.
2. Pin (A) of camshaft engages in bore hole of camshaft sprocket.

### TORQUE — ANGLE METHOD

1. Camshaft sprocket to camshaft — 50 Nm. + 60° + 15°. Use new bolt. During installation, counterhold on hex of camshaft.

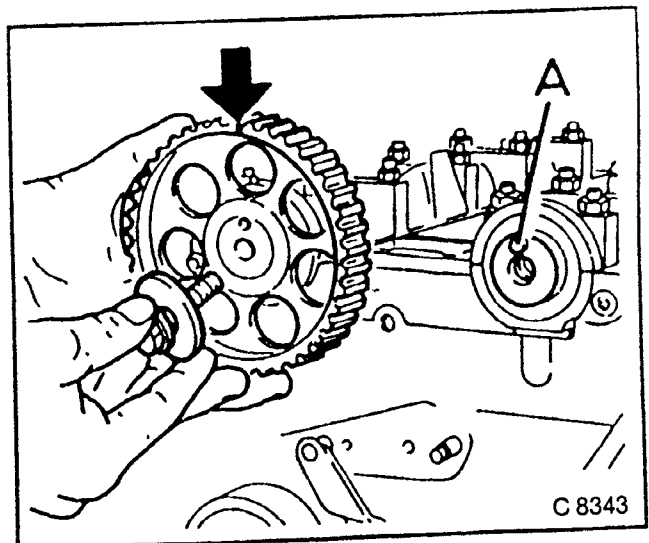


Fig. 411

## INSTALL, CONNECT

1. Cylinder head cover with new gasket.
2. Hose connections (arrows) to cylinder head cover.
3. Spark plug connection.
4. Ignition cable cover.
5. New toothed belt — see “Toothed Belt, Replace”, page 184.

## TIGHTEN (TORQUE)

1. Cylinder head cover to cylinder head — 8 Nm.
2. Ignition cable cover to cylinder head cover — 8 Nm.

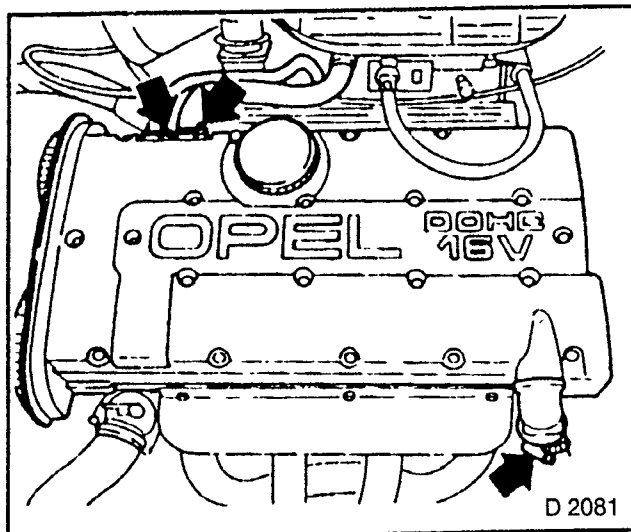


Fig 412

## Cylinder Head — Remove and Install

**WARNING:**  
REMOVE CYLINDER HEAD ONLY WITH COLD ENGINE (ROOM TEMPERATURE).

### REMOVE, DISCONNECT

1. Ground cable from battery.
2. Engine compartment cover.
3. Lower hose bend (arrow) from radiator — collect coolant.
4. Toothed belt — see “Toothed Belt, Replace”, page 184.

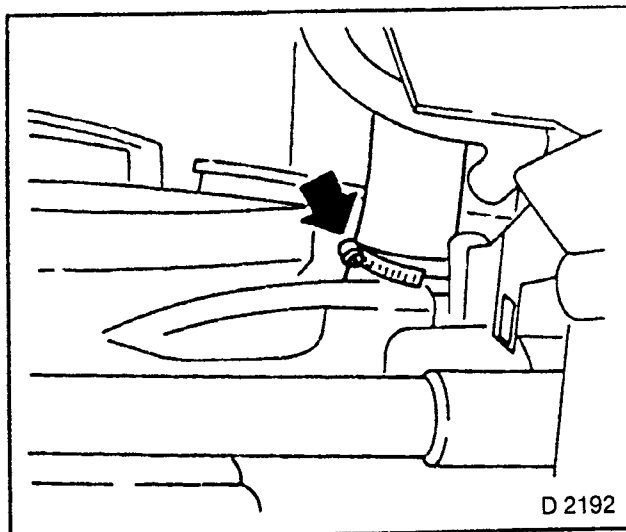


Fig. 413

### REMOVE, DISCONNECT

1. Camshaft sprockets.
2. Fan manifold.
3. Wiring plug (1) from mass air flow meter.
4. Hose.
5. Idle speed adjuster (2) from pre-volume chamber.
6. Pre-volume chamber with mass air flow meter (3).

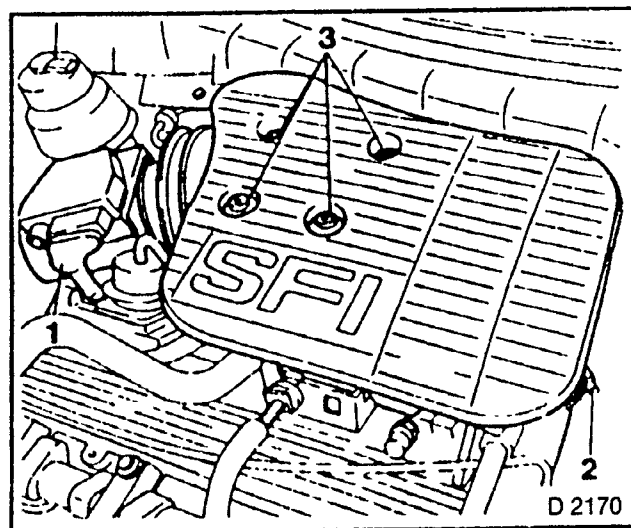


Fig. 414

**REMOVE, DISCONNECT**

1. Upper hose bend and wiring plug from thermostat housing.
2. Fastening bolt (arrow) from cylinder head.
3. Wiring plug and high voltage cable from ignition coil.
4. Wiring plug from high voltage distributor.
5. Coolant hose.
6. Multiple plug.

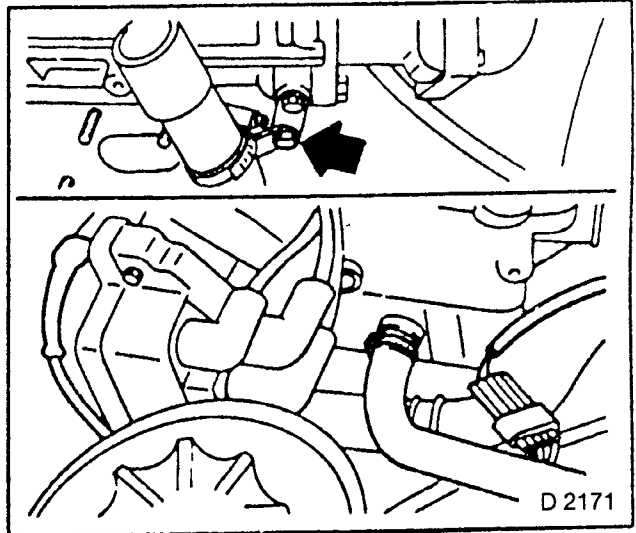


Fig. 415

**REMOVE, DISCONNECT**

1. Bowden cable.
2. Fuel lines — close with spring clamps.

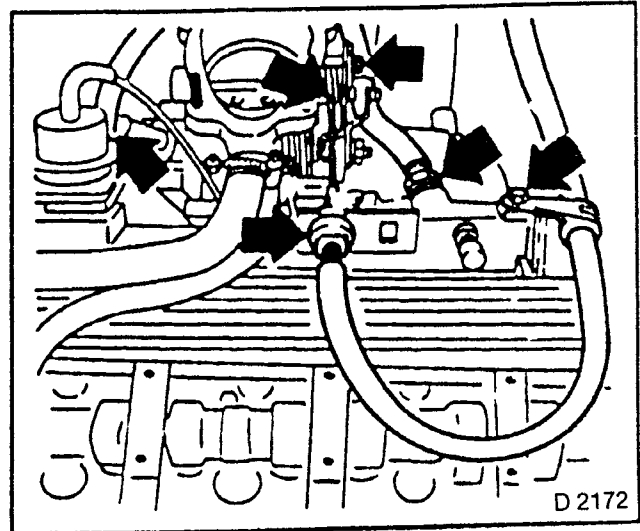


Fig. 416

**REMOVE, DISCONNECT**

1. Contact strip from injection valves.
2. Wiring plug (1) from throttle valve switch.
3. Ground connections (2) from fuel distributor pipe.
4. Wiring plug (3) from tank vent valve.
5. Lay aside injection valve contact strip to rear.

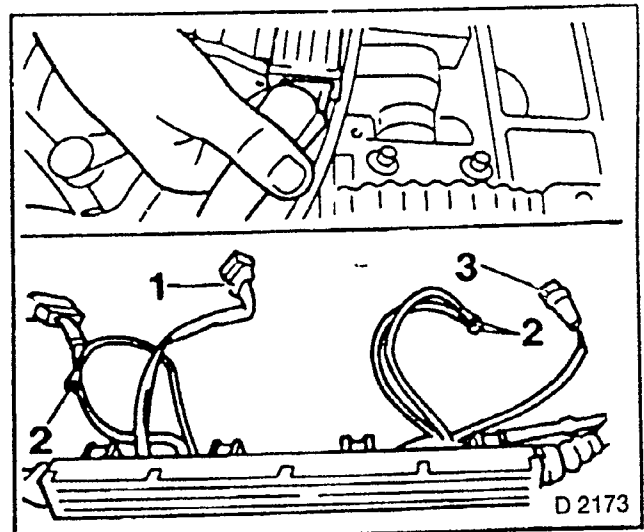


Fig. 417

**REMOVE, DISCONNECT**

1. Wiring plug from idle speed adjuster (1).
2. Brake servo vacuum line from intake pipe (2).
3. Intake pipe — cylinder block support from intake pipe (3).
4. Compensation — tank coolant pipe hose from coolant pipe (4).

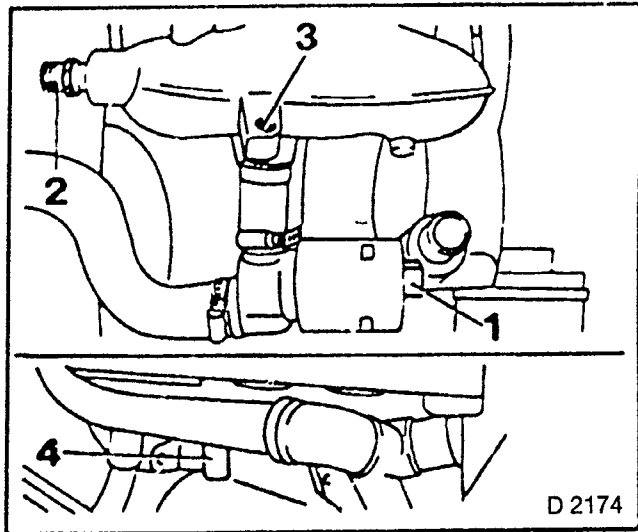


Fig. 418

**REMOVE, DISCONNECT**

1. Wiring plug from knock sensor (between starter and coolant pipe).
2. Rear toothed belt cover from cylinder head.

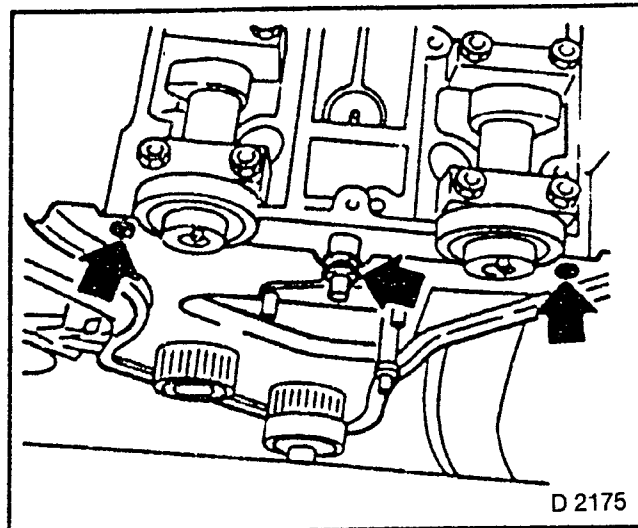


Fig. 419

**REMOVE, DISCONNECT**

1. Cylinder head bolts in illustrated order with MKM-604-19 (Torx Nut E 14).

**NOTE:**  
**LOOSEN CYLINDER HEAD BOLTS WITH FIRST 1/4, THEN 1/2 TURN.**  
**WHEN REMOVING CYLINDER HEAD BOLTS, NOTE STEEL WASHERS.**

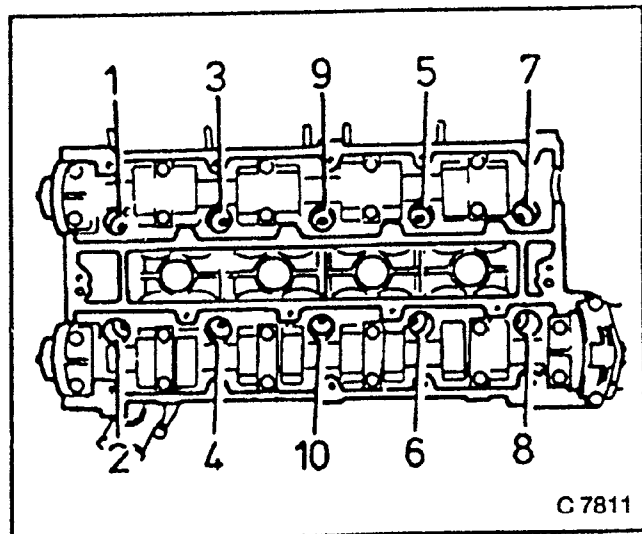


Fig. 420

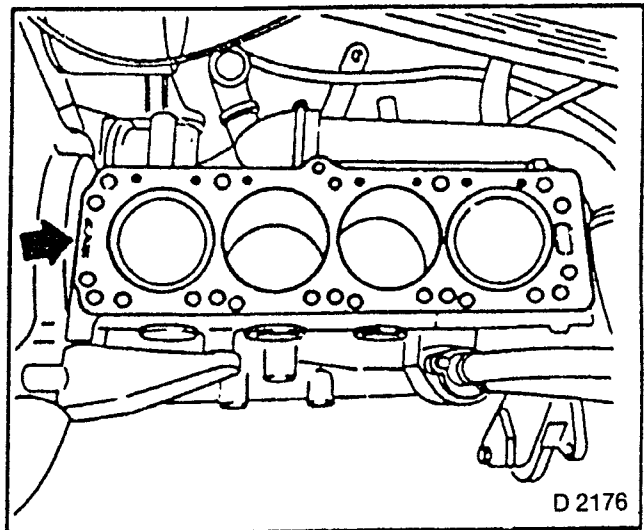
C 7811

**CLEAN**

1. All sealing surfaces.
2. Drill holes of cylinder head bolts.
3. Check cylinder block and cylinder head for plane washer.

**INSTALL, CONNECT**

1. New cylinder head gasket — mark "OBEN/TOP" upwards and towards timing side of engine.

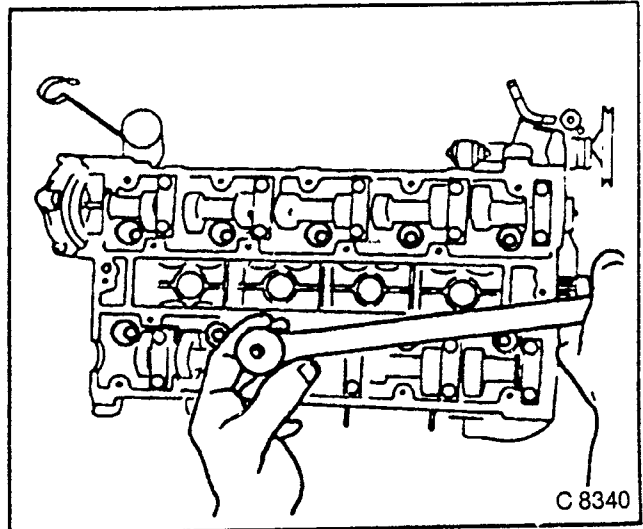


D 2176

Fig. 421

2. Place cylinder head on cylinder block.
3. Insert steel washers and cylinder head bolts.

**NOTE:**  
**USE NEW CYLINDER HEAD BOLTS.**  
**SCREW IN BOLTS UP TO STOP**  
**WITH MKM-604-19 (TORX NUT E 14).**

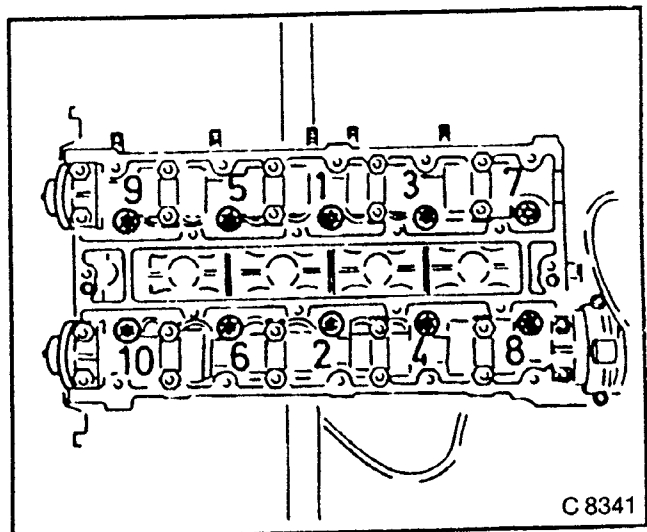


C 8340

Fig. 422

**TORQUE — ANGLE METHOD**

1. Cylinder head to cylinder block.  
 Tighten cylinder head bolts in illustrated order, in four stages — Torque Wrench KM-470-B.  
 Tightening mode: 25 Nm + 65° + 65° + 65°.
2. After test run, turn a further 30° + 15°.



C 8341

Fig. 423



**TIGHTEN (TORQUE)**

1. Rear toothed belt cover to cylinder head — 6 Nm.
2. Connect knock sensor wiring plug (between starter and coolant pipe).
3. Install compensation tank — coolant pipe hose to coolant pipe (4).
4. Intake pipe — cylinder block support to intake pipe (3) — 25 Nm.
5. Brake servo vacuum line to intake pipe (2) — 15 Nm.
6. Connect wiring plug to idle speed adjuster (1).

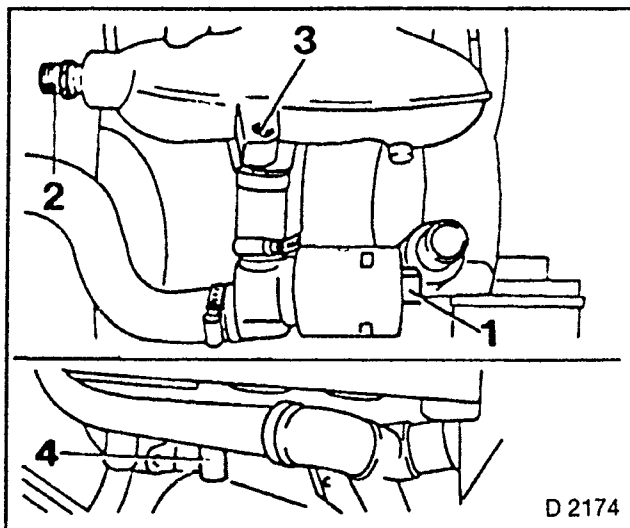


Fig. 424

**INSTALL, CONNECT**

1. Wiring plug (1) to throttle valve switch.
2. Ground connections (2) to fuel distributor pipe.
3. Wiring plug (3) to tank vent valve.
4. Injection valve contact strip.
5. Check all ground connections for perfect condition and firm seating.

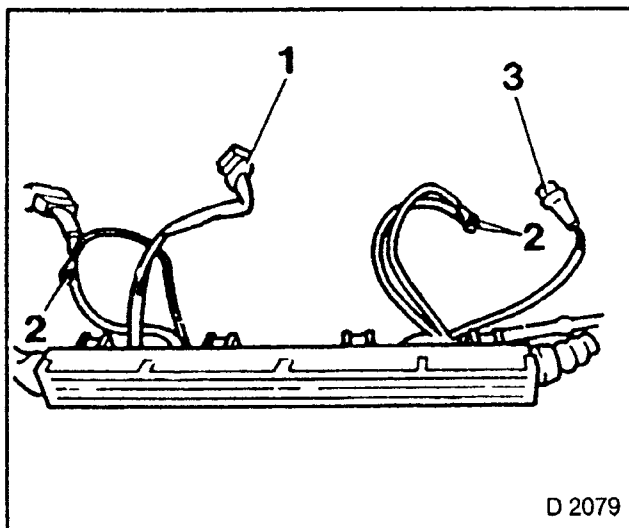


Fig. 425

**INSTALL, CONNECT**

1. Fuel lines.
2. Bowden cable.

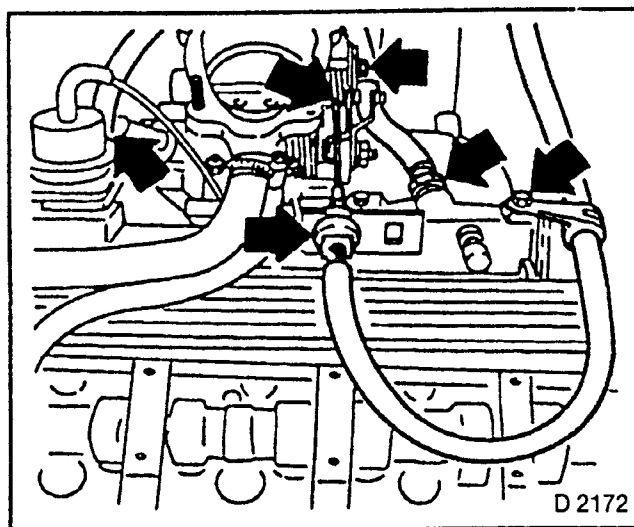


Fig. 426

**INSTALL, CONNECT**

1. Coolant hose to cylinder head.
2. Multiple plug.
3. Wiring plug and high voltage cable to ignition coil.
4. Wiring plug to high voltage distributor.
5. Fastening bolt (arrow) to cylinder head.
6. Wiring plug and upper hose bend to thermostat housing.

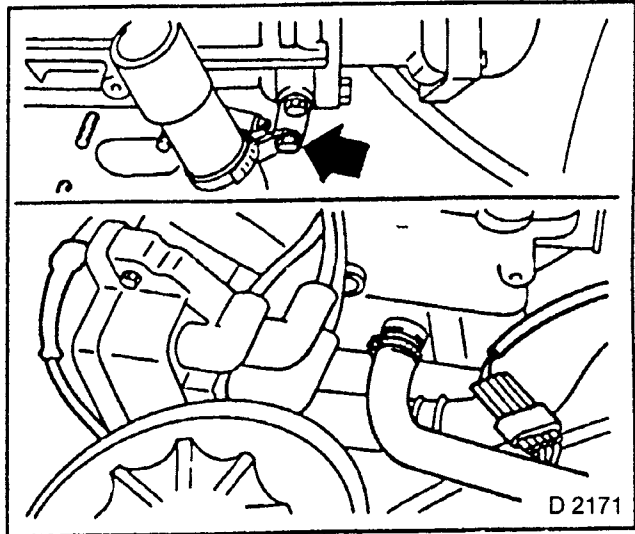


Fig. 427

**INSTALL, CONNECT**

1. Pre-volume chamber with mass air flow meter (3).
2. Idle speed adjuster hose to pre-volume chamber (2).
3. Mass air flow meter wiring plug (1).
4. Lower hose bend to radiator.
5. Fan manifold.
6. Camshaft sprockets.
7. New toothed belt.
8. Engine compartment cover.
9. Ground cable to battery.
10. Top up and bleed cooling system.
11. Check for leaks.

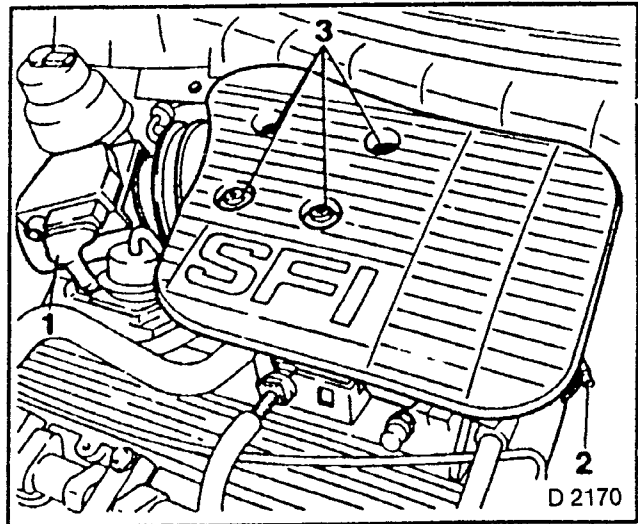


Fig 428

# Cylinder Head — Disassemble and Assemble

## REMOVE, DISCONNECT

1. Cylinder head.
2. High voltage distributor.
3. Intake pipe.
4. Thermostat housing.
5. Spark plugs with KM-194.

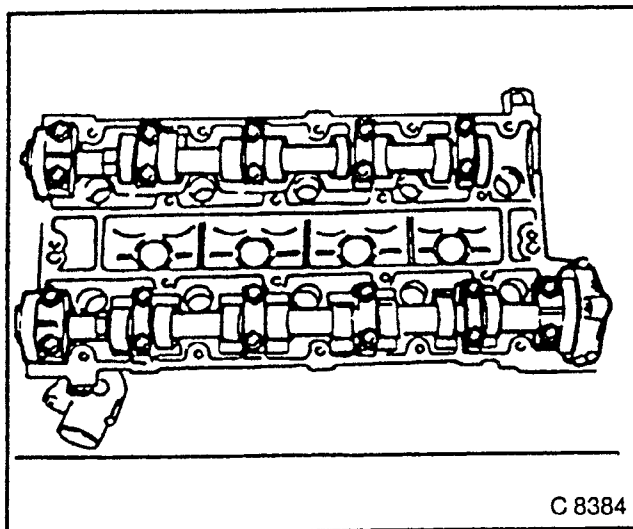
## REMOVE, DISCONNECT

1. Camshaft bearing cover.
2. Loosen nuts in stages — 1/2 to full turn.

### WARNING:

**THE CAMSHAFT MUST BE EVENLY AND REGULARLY LOOSENED FROM BEARING SEAT — FRONT GUIDE BEARING.**

3. Remove camshaft.



C 8384

Fig 429

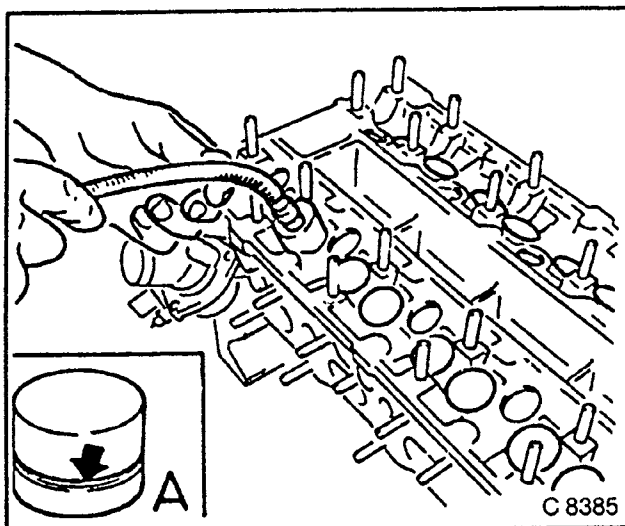
## REMOVE, DISCONNECT

1. Hydraulic valve lifter with rubber sucker.

**NOTE:  
PLACE VALVE LIFTER (A) IN  
INSTALLATION POSITION (GROOVE  
IN LOWER AREA).**

## DISASSEMBLE

NOT anticipated for valve lifter.



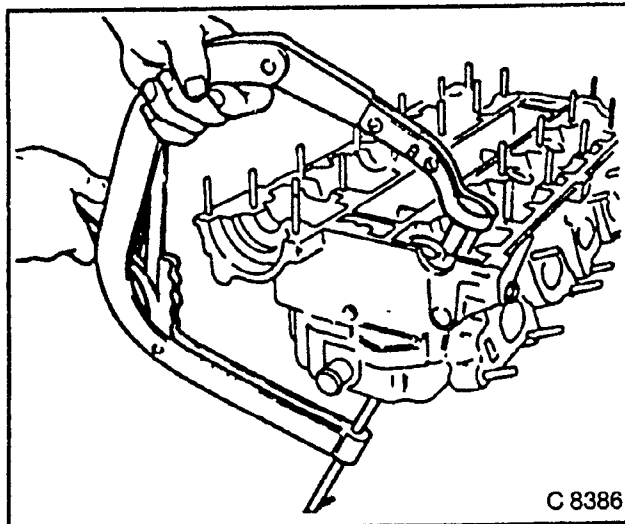
C 8385

Fig. 430

1. Mark valves.
2. Tension valve spring with KM-348 and Adapter KM-653.

## REMOVE, DISCONNECT

1. Valve spring plate.
2. Valve cones.
3. Valve spring.



C 8386

Fig. 431

**REMOVE, DISCONNECT**

1. Valve stem seal.
2. Valve spring washer.
3. Valve.

**CAUTION:**  
**SODIUM-FILLED EXHAUST VALVES**  
**MUST NOT BE DISPOSED OF WITH**  
**"NORMAL SCRAP".**  
**OBSERVE LEGAL REGULATIONS**  
**WHEN DISPOSING OF SODIUM-**  
**FILLED EXHAUST VALVES.**

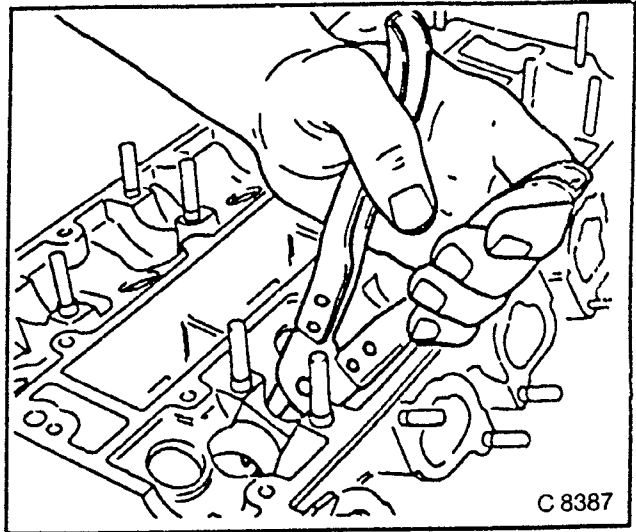


Fig. 432

**CLEAN****INSPECT**

1. Individual parts.
2. Sealing surfaces.
3. Guide.
4. Sliding and bearing parts.

**WARNING:**  
**DO NOT DAMAGE VALVE SEATS.**

5. Overhaul cylinder head.

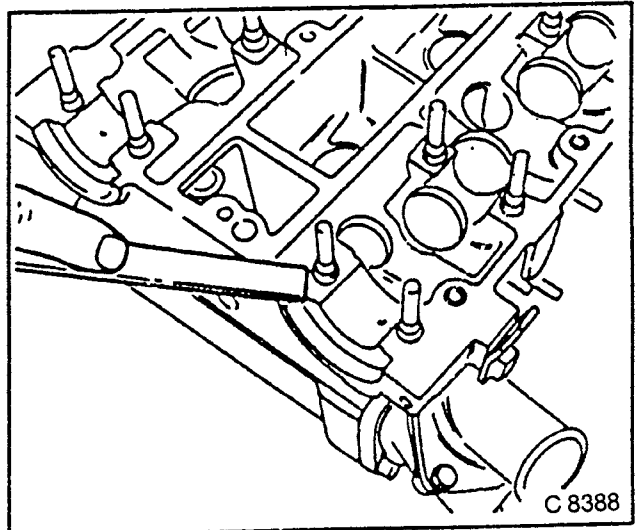


Fig. 433

**WARNING:**

1. Insert valves with engine oil.
2. Insert valve spring washer.
3. Coat inside of Installer KM-663 thinly with grease.
4. Insert new valve stem seal.

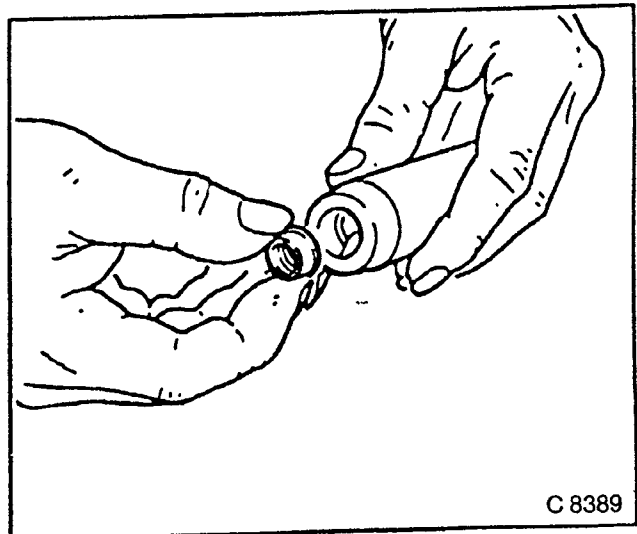


Fig. 434

5. Cut installer sleeve (included in package) to required length and push on to valve stem.
6. Place installer KM-663 with valve stem seal onto guide and **carefully** drive in to stop with LIGHT hammer blows.

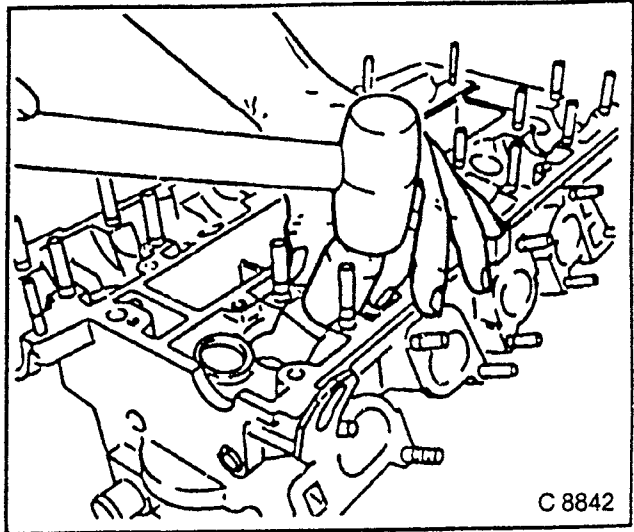


Fig. 435

## INSTALL, CONNECT

1. Valve spring.
2. Valve spring plate.
3. Valve cones with KM-348 and Adapter KM-653.
4. Valve lifter.
5. Coat sliding surfaces of valve lifter.
6. Camshaft with MoS<sub>2</sub> paste.
7. Insert camshaft.

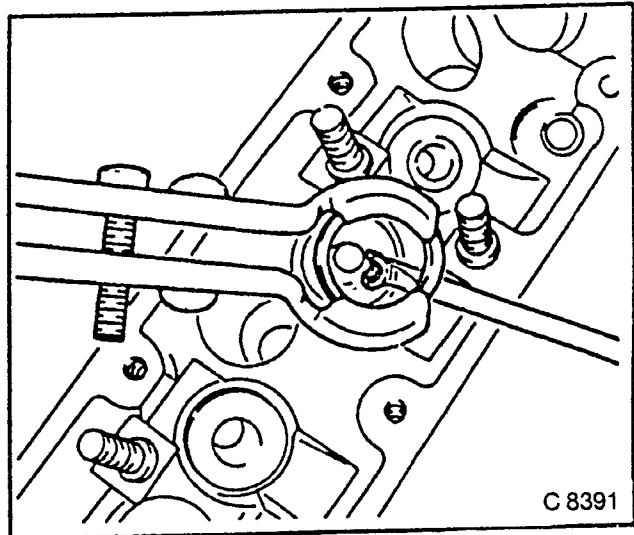


Fig. 436

8. Apply Sealing Compound Loctite 515 flexible gasket or equivalent to the sealing surfaces of outer camshaft bearing cover.

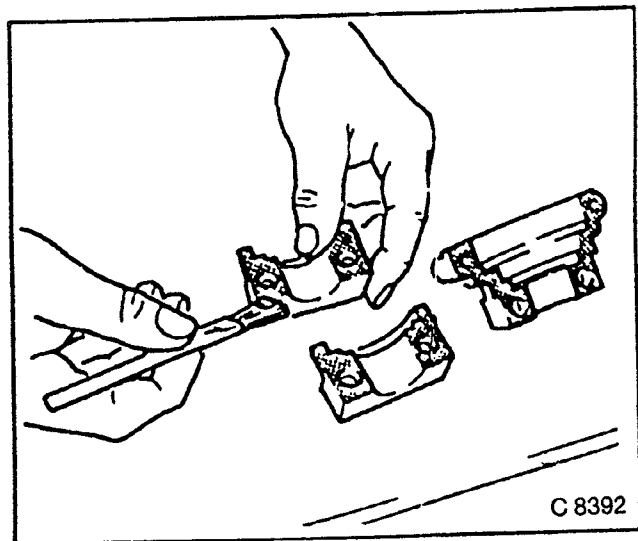
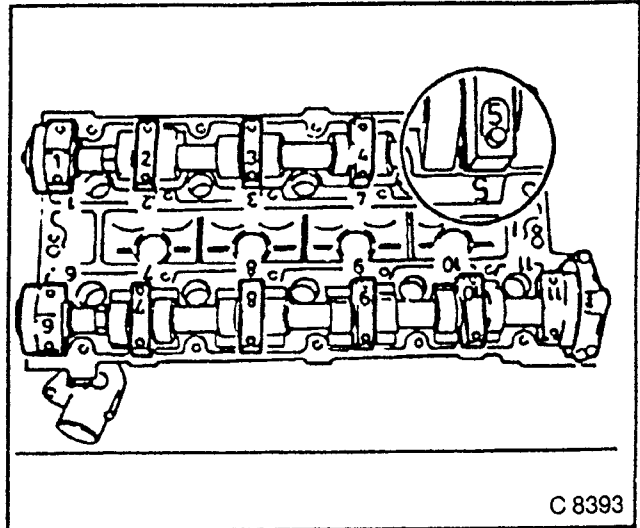


Fig. 437

**INSTALL, CONNECT**

1. Camshaft bearing cover.

**NOTE:**  
IDENTIFICATION NUMBERS OF  
CAMSHAFT BEARING COVER  
MUST MATCH THOSE IN CYLINDER  
HEAD.



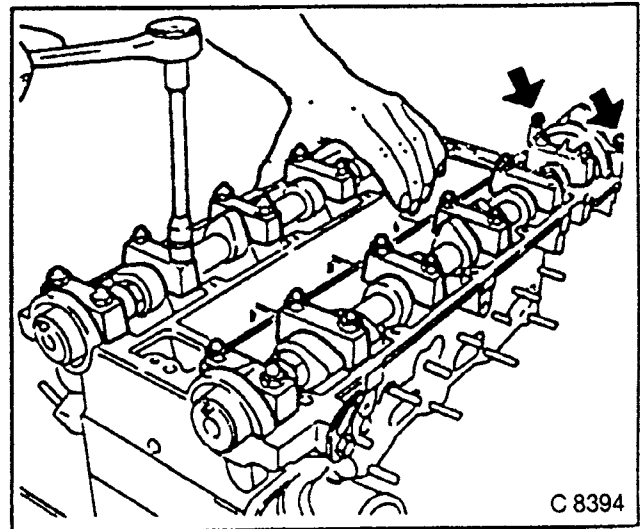
C 8393

Fig 438

**TIGHTEN (TORQUE)**

1. Camshaft bearing cover to cylinder head (M8) — 20 Nm.
2. Rear camshaft bearing cover to cylinder head (M6) — 10 Nm.

**WARNING:**  
INSTALL CAMSHAFT BEARING  
COVER FROM INSIDE OUTWARDS.  
INSTALL FASTENING NUTS IN  
STAGES — 1/2 TO FULL TURN.



C 8394

Fig 439

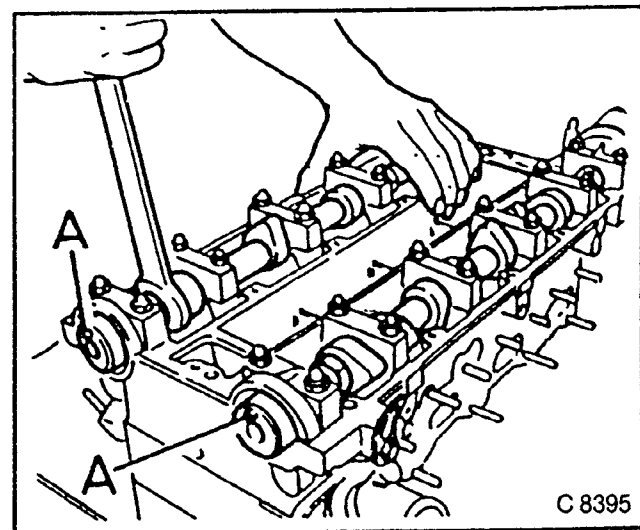
3. Turn camshaft with wrench so that pin (A) points upwards.

**INSTALL, CONNECT**

1. New camshaft seal rings with KM-422 — use bolt and washer of camshaft sprocket.
2. Coat seal lips of seal ring with protective grease.

**TIGHTEN (TORQUE)**

1. Spark plug in cylinder head — 25 Nm. Use KM-194.
2. Thermostat housing to cylinder head — 15 Nm. Use new seal ring.
3. Intake pipe to cylinder head — 22 Nm. Use new gasket.
4. Install high voltage distributor and cylinder head.



C 8395

Fig. 440

## Exhaust Valve (Sodium-filled) — Disposal

**CAUTION:**  
SODIUM-FILLED EXHAUST VALVES  
MUST NOT BE DISPOSED OF WITH  
“NORMAL SCRAP”. OBSERVE  
LEGAL REGULATIONS WHEN  
DISPOSING OF SODIUM-FILLED  
EXHAUST VALVES.

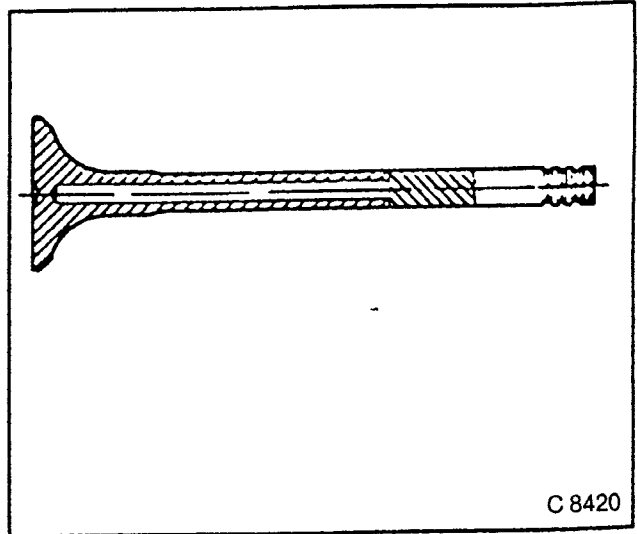


Fig. 441

## Cylinder Head — Overhaul

CYLINDER HEAD DISASSEMBLED

### VALVE — GRIND IN

1. Oil valve stem, use fine-grained grinding paste.
2. Lift valve up rhythmically from seat — distribution of grinding paste.

### CLEAN

1. Valves.
2. Cylinder head.

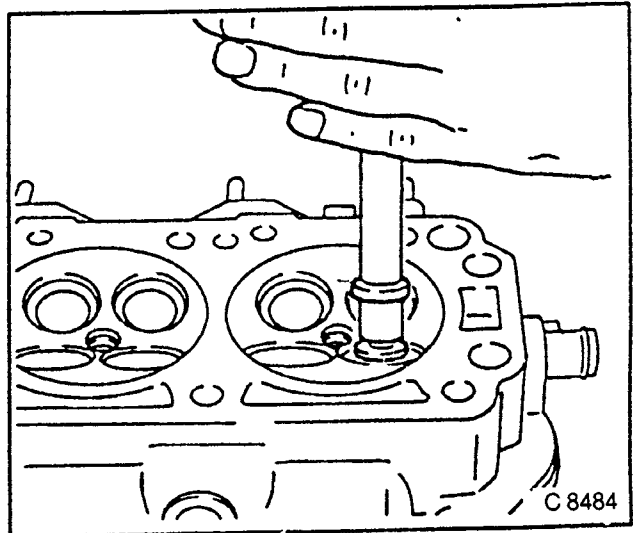


Fig. 442

### VALVE, GRIND

**NOTE:**  
NO CRATER-LIKE BURNS ON  
VALVE CONE.  
REGRINDING POSSIBLE ONCE OR  
TWICE.  
ANGLE AT VALVE HEAD:  $45^{\circ} 20'$ .  
INSTALLATION HEIGHT OF INLET  
AND EXHAUST VALVE, UPPER  
EDGE OF STEM — VALVE SPRING  
WASHER BEARING SURFACE: See  
“Technical Data”, PAGE 312.

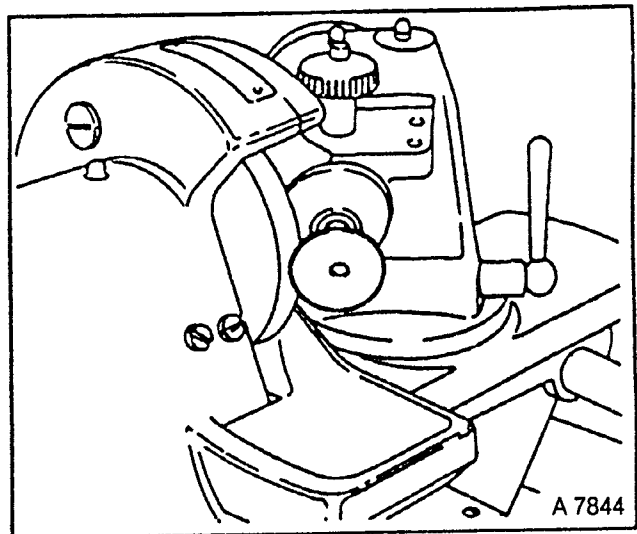


Fig. 443

## Valve Guide — Ream

### MEASURE

Diameter of valve guide — dial gauge and internal measuring instrument.

**NOTE:**  
**OVERSIZE VALVES MAY ALREADY BE FACTORY-INSTALLED.**  
**OVERSIZE IDENTIFICATION:**  
**ON THE VALVE GUIDE AND AT THE VALVE STEM END WITH THE FOLLOWING IDENTIFICATION NUMBERS/LETTERS.**  
**SEE ALSO "TECHNICAL DATA", PAGE 312.**

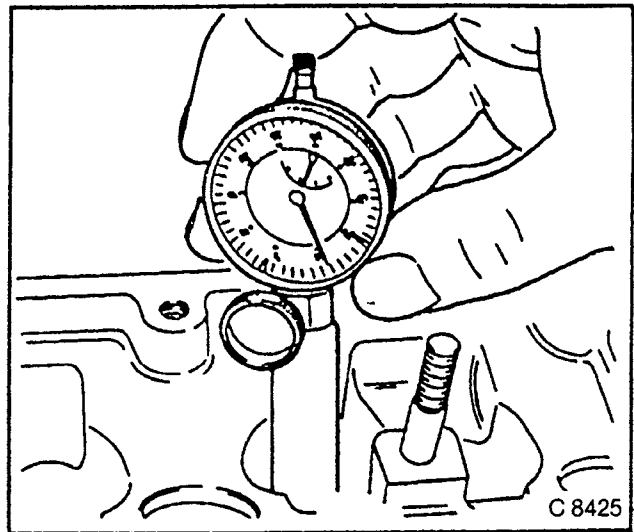


Fig. 444

| Size   | Reamer   | Identification |         |
|--------|----------|----------------|---------|
|        |          | Production     | Service |
| Normal |          | none           | K       |
| 0,075  | KM-664-1 | 1              | K 1     |
| 0,150  | KM-664-2 | 2              | K 2     |

2. Rear valve guide from upper side of cylinder head to next oversize.
3. After reaming, cross out identification and stamp in new identification.

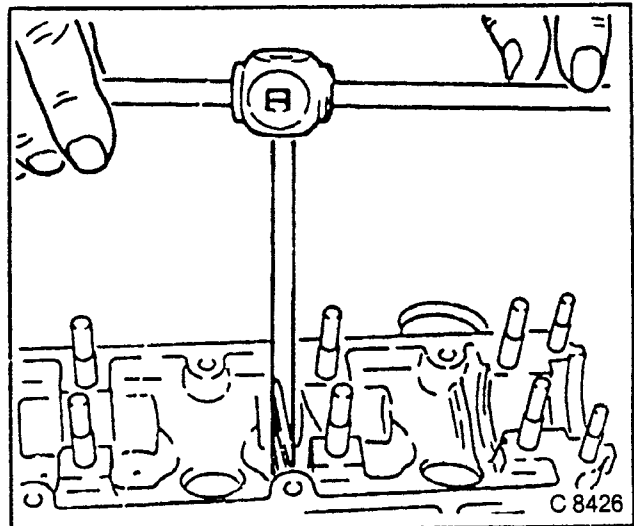


Fig. 445

## Valve Seat — Cut

Lay cylinder head on wooden blocks.

**NOTE:**  
**REWORKING TO VALVE SEAT PERMISSIBLE TO 0,4 MM.**

### INSTALL, CONNECT

Guide Drift KM-340-7.

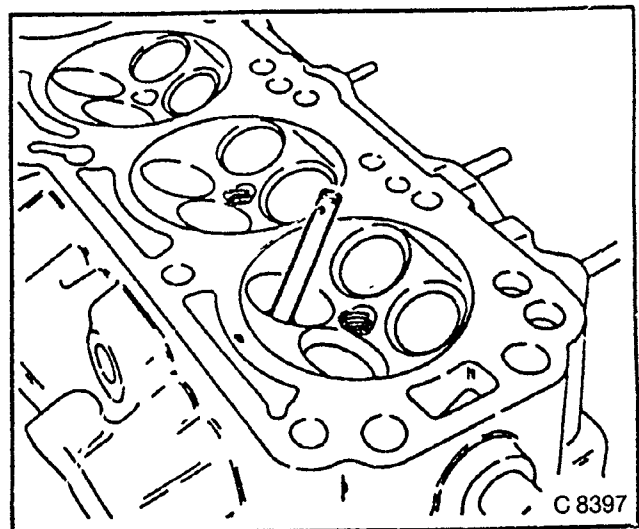


Fig. 446



**INSTALL, CONNECT**

1. KM-340-12.
2. Valve seat — 45° side, upper correction — 30° side.

**NOTE:**  
**NOTE ARROW ON CUTTER.**

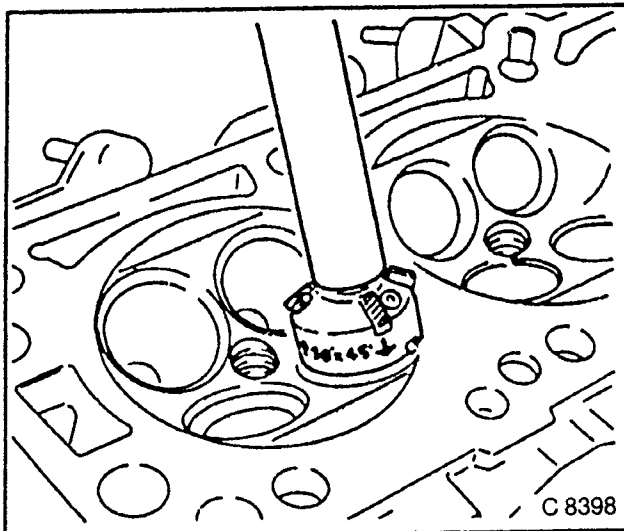


Fig. 447

**INSTALL, CONNECT**

1. KM-340-26.
2. Lower correction — 60°.

**NOTE:**  
**INSTALLATION HEIGHT OF INLET AND EXHAUST VALVE, UPPER EDGE OF STEM — VALVE SPRING WASHER BEARING SURFACE: SEE "TECHNICAL DATA", PAGE 312.**

**CLEAN**

Cylinder head of chippings.

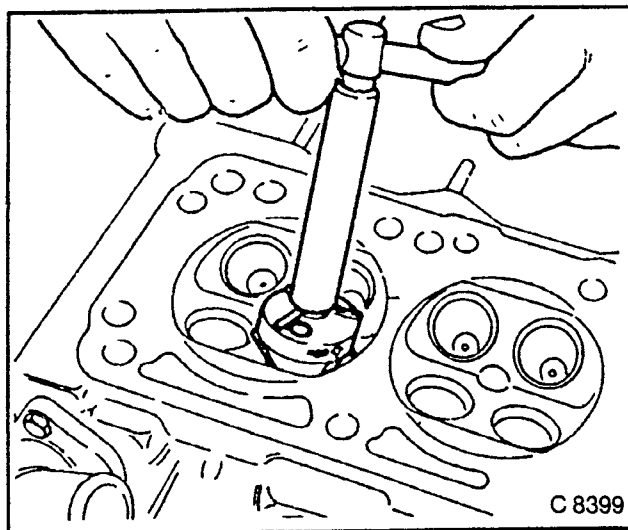


Fig. 448

**INSPECT**

1. Valve seat width: inlet (A), exhaust (B).
2. Grind in valve.
3. Carry out test for leaks with cleaning petrol.

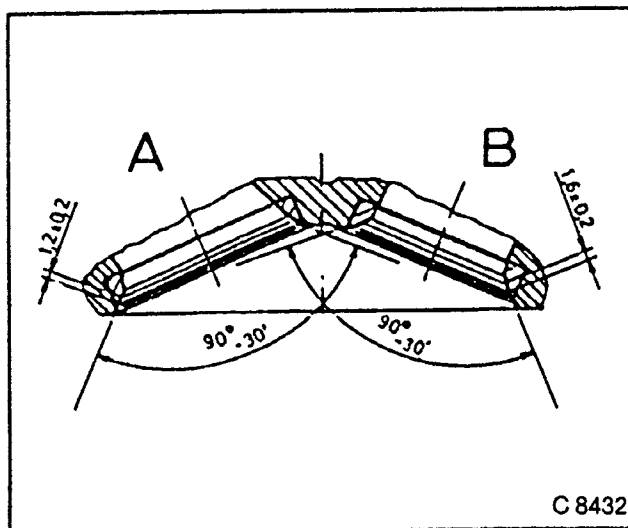


Fig. 449

# Cylinder Head — Check for Plane Surface

## CLEAN

Cylinder head sealing surface.

## INSPECT

1. Cylinder head length and breadth for deformation and the diagonals for distortion — straight edge and feeler gauge.  
Permissible deviation: 0,05 mm.

## WARNING:

Plane grinding of cylinder head permissible **only within** given tolerances.  
Total height of cylinder head: 135.58 to 135.68 mm. (sealing surface to sealing surface).

# Crank Drive

## RECOMMENDED TORQUE VALUES

|   | Nm                                   |
|---|--------------------------------------|
| Con-rod bearing cover to con-rod .....                                | 35 + 45° + 15° <sup>3)</sup>         |
| Cylinder head to cylinder block .....                                 | 25 + 65° + 65° + 65° <sup>3)3)</sup> |
| Flywheel to crankshaft .....  | 65 + 30° + 15° <sup>3)</sup>         |
| Front toothed belt cover to cylinder head, adapter and oil pump ..... | 8                                    |
| Oil pan to cylinder block .....                                       | 15 <sup>1)3)</sup>                   |
| Rear toothed belt cover to cylinder block .....                       | 6                                    |
| Toothed belt drive pinion to crankshaft .....                         | 250 + 40° to 50° <sup>3)4)</sup>     |
| Wheel bolts to front wheel hub .....                                  | 110                                  |

- 1) Insert bolts using Locking Compound Loctite 242
- 2) Installation time maximum 10 mins
- 3) Use new bolt(s).
- 4) Insert bolt using grease
- 5) After test run turn a further 30° + 15°

# Rear Crankshaft Seal Ring — Replace

## REMOVE, DISCONNECT

1. Clutch.
2. Thrust bearing.
3. Guide sleeve for thrust bearing — Section K.
4. Flywheel.

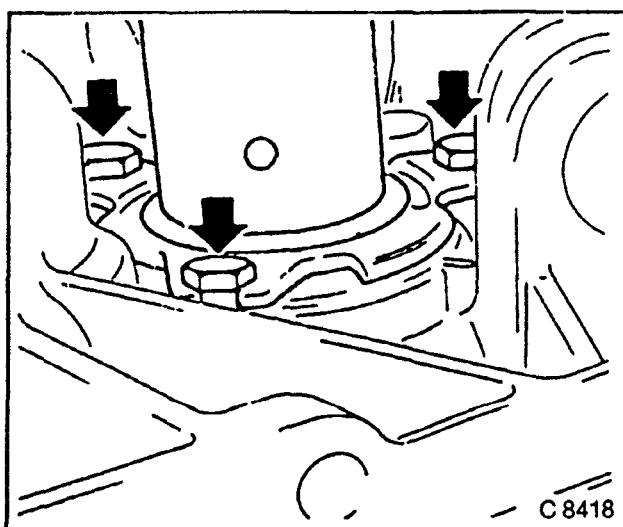


Fig. 450

**INSTALL, CONNECT**

1. Hook KM-665 between sealing lip and crankshaft journal.

**ASSEMBLE**

1. Support KM-469-4.
2. Lever KM-469-13-A.
3. Pin KM-328-8.

**REMOVE, DISCONNECT**

1. Shaft seal ring.

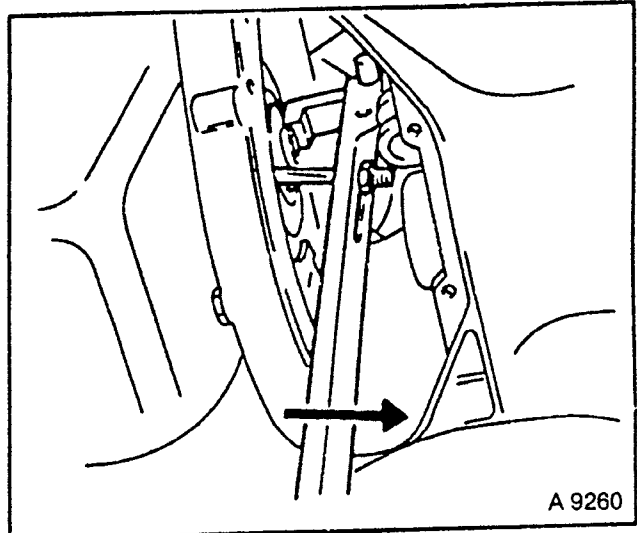


Fig. 451

2. Coat sealing lips of shaft seal ring with protective grease.

**INSTALL, CONNECT**

1. Seal ring on crankshaft journal.
2. Protective Sleeve KM-635-1.
3. Thrust Collar KM-635-2 on seal ring.

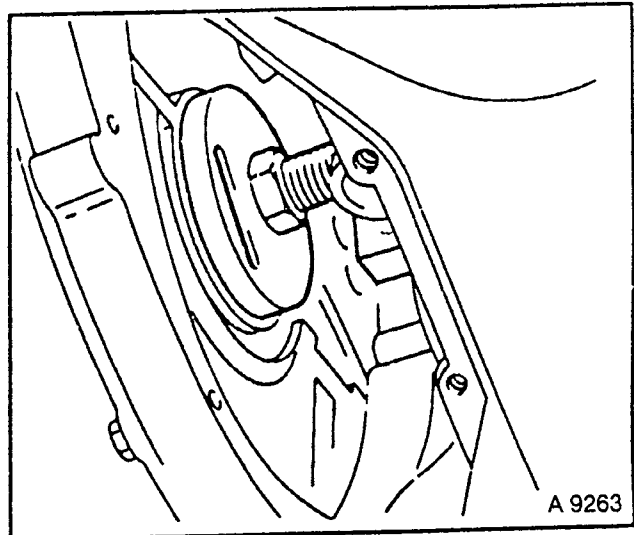


Fig. 452

**INSTALL, CONNECT**

1. Seal ring firmly in cylinder block.
2. Retaining Plate KM-511-11.
3. Hex Bolt KM-469-12-B.

**NOTE:  
INSERT LOCATING PINS INTO  
HOLES ON TRANSMISSION.**

3. Remove assembly.
4. Install flywheel.
5. Guide sleeve.
6. Thrust bearing.
7. Clutch.

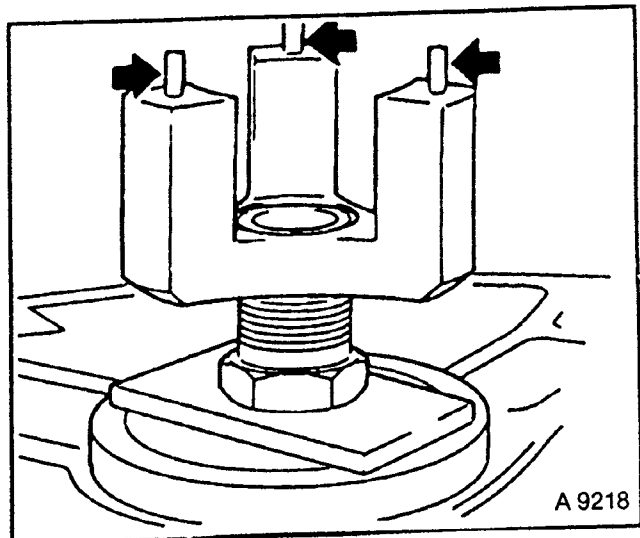


Fig. 453

## Seal Ring — Rear Crankshaft — Replace (Version with Pot Flywheel)

### REMOVE, DISCONNECT

1. Transmission, clutch — Section K.
2. Pot flywheel.

### REMOVE, DISCONNECT

1. Make hole in middle of seal ring. Screw in self-tapping screw and edge out.

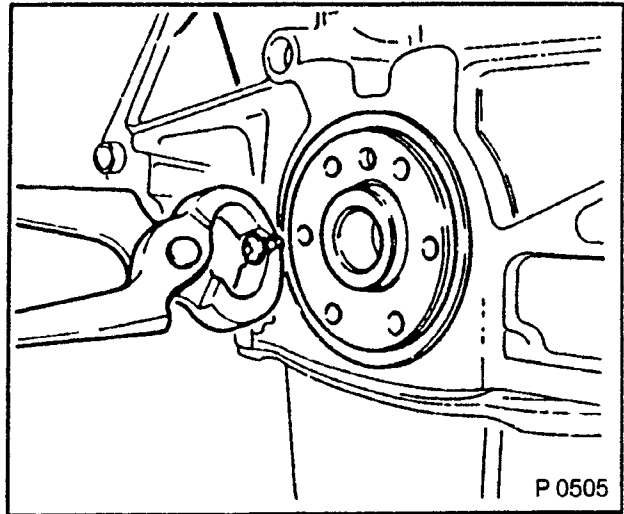


Fig. 454

### INSTALL, CONNECT

1. Seal ring — Protective Sleeve KM-635-1.
2. Coat sealing lip of shaft seal ring with protective grease.
3. Thrust Ring KM-635-2, KM-535.

### INSTALL, CONNECT

1. Clutch, transmission — Section K.
2. Pot flywheel.

## Crankshaft Front Seal Ring (Oil Pump Housing) — Replace

### REMOVE, DISCONNECT

1. Right front wheel.
2. Toothed belt — see "Toothed Belt, Replace", page 184.

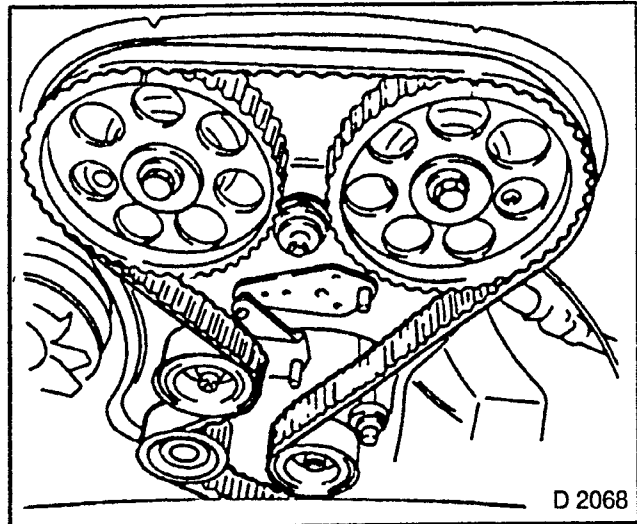


Fig. 455

**REMOVE, DISCONNECT**

1. Toothed belt drive gear.
2. Install MKM-604-21 (Torx Nut E 20).
3. Holding Wrench KM-662-A — follow manufacturer's Instructions.
4. If necessary, install Remover KM-210-A with KM-516 and KM-647.
5. Remove toothed belt drive gear.

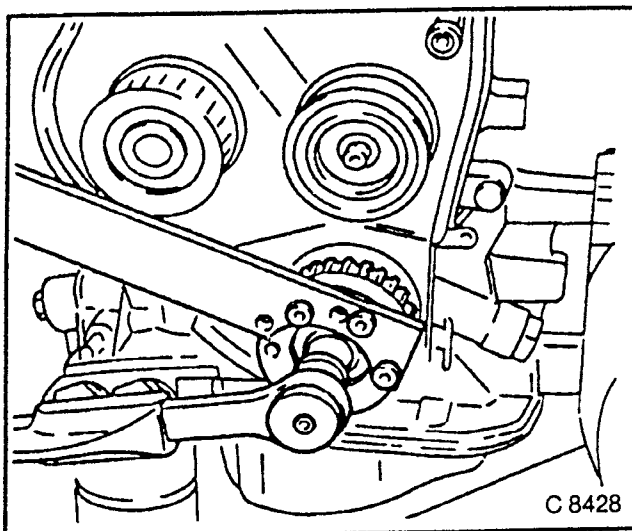


Fig. 456

**REMOVE, DISCONNECT**

1. Spacing ring.
2. Seal ring — make hole in middle of ring.
3. Turn in self-tapping screw and edge out.

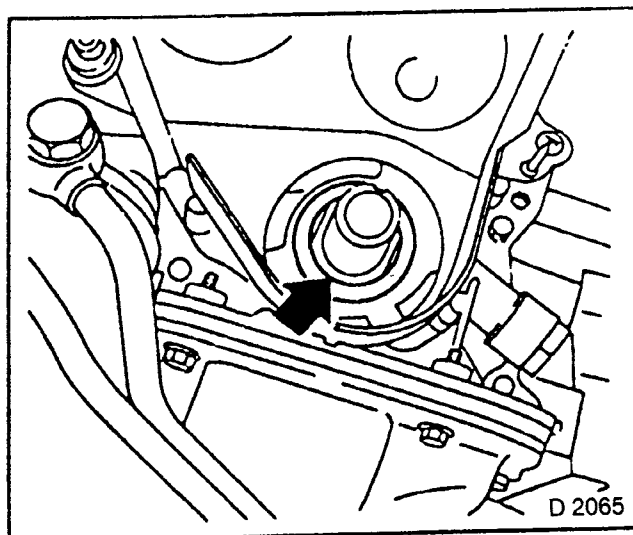


Fig. 457

**INSTALL, CONNECT**

1. Seal ring with KM-693.
2. Use torx bolt (1) and washer (2) of toothed belt drive gear.
3. Coat sealing lips of seal ring with protective grease.

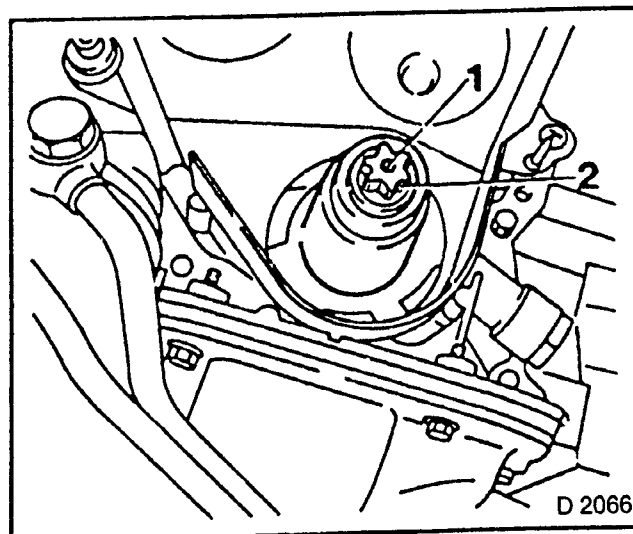


Fig. 458

**INSTALL, CONNECT**

1. Spacing ring on crankshaft journal — coat fore part thinly with Sealing Compound Loctite 515 flexible gasket or equivalent.
2. Toothed belt drive gear on crankshaft journal — observe installation position.

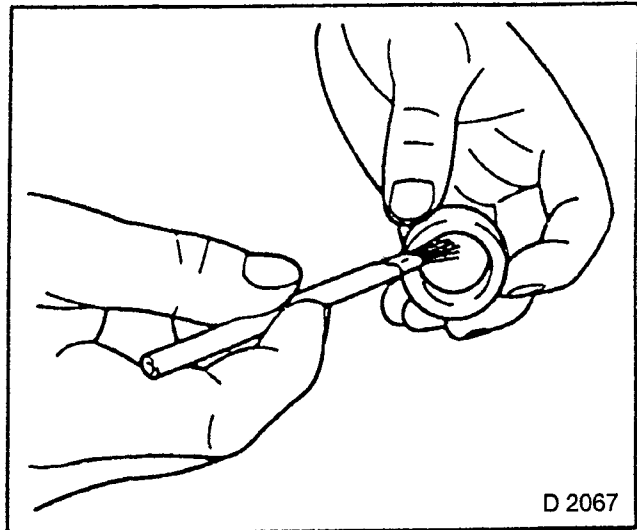


Fig. 459

**TORQUE — ANGLE METHOD**

1. Toothed belt drive gear to crankshaft — 250 Nm. + 40° to 50°. Use new bolt.

**NOTE:  
INSERT FASTENING BOLT OF  
TOOTHED BELT DRIVE GEAR WITH  
GREASE.**

2. When installing, mount MKM-604-21 (Torx Nut E 20) and Holding Wrench KM-662-A as illustrated — observe manufacturer's instructions.

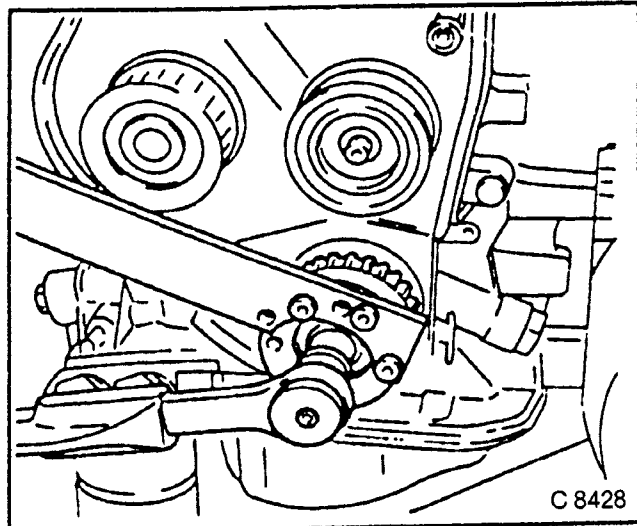


Fig. 460

**INSTALL, CONNECT**

1. New toothed belt — see "Toothed Belt, Replace", page 168.
2. Right front wheel.

**TIGHTEN (TORQUE)**

1. Wheel bolts to front wheel hub — 110 Nm.

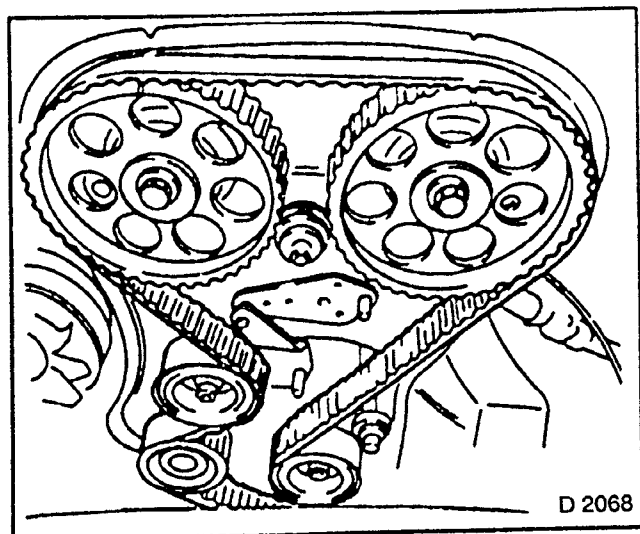


Fig. 461

## Piston with Con-rod — Remove and Install

### REMOVE, DISCONNECT

1. Cylinder head.
2. Oil pan — see "Gasket Oil Pan, Replace", page 208.
3. Piston with con-rod.
4. Mark con-rod bearing cap.

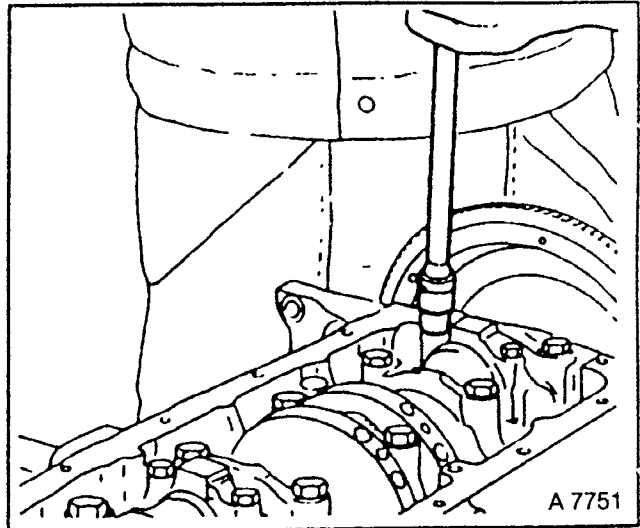


Fig. 462

### INSPECT

Replace all parts if necessary.

**NOTE:**  
RING GAP OFFSET OF PISTON RINGS — 180°. UPPER STEEL BAND RING 25 TO 50 MM TO LEFT AND UPPER STEEL BAND RING 25 TO 50 MM TO RIGHT OF GAP OF INTERMEDIATE RING.

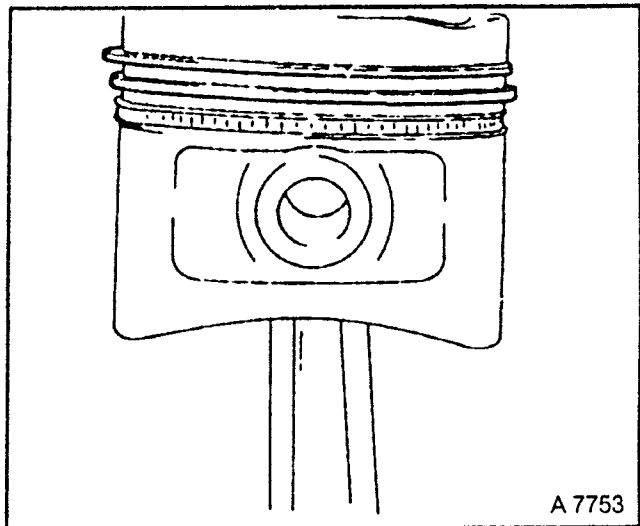


Fig. 463

### INSTALL, CONNECT

1. Piston with con-rod — insert with engine oil.

**NOTE:**  
NOTE INSTALLATION POSITION. ARROW ON PISTON HEAD POINTS TO ENGINE TIMING SIDE. BEADS ON CON-ROD (ARROWS) TO CLUTCH SIDE.

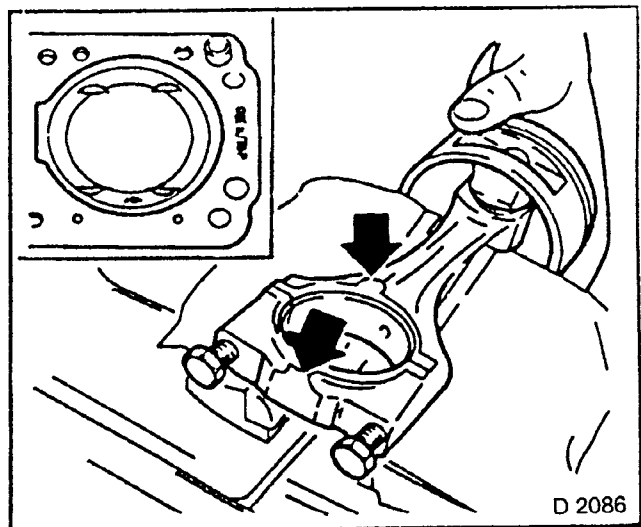


Fig. 464

**TORQUE — ANGLE METHOD**

1. Con-rod bearing cap to con-rod — 35 Nm. + 45° + 15°. Use new bolts.
2. Install oil pan.
3. Cylinder head.

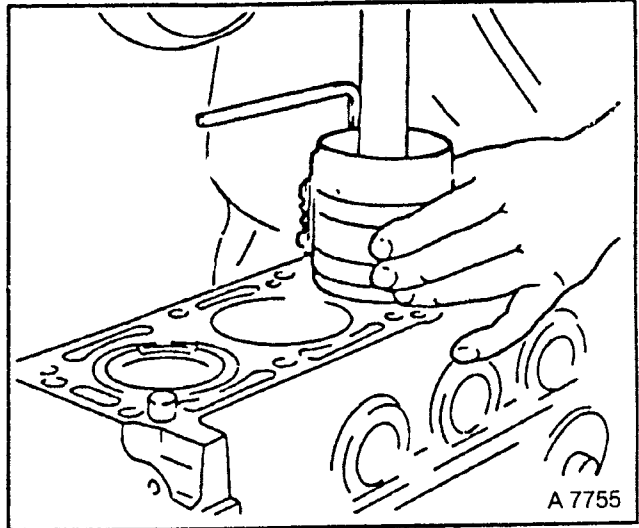


Fig 465

**Con-Rod Bearing — Replace****REMOVE, DISCONNECT**

1. Oil pan.
2. Con-rod bearing cap — mark.
3. Con-rod bearing.

**CLEAN**

1. Con-rod journal.
2. Con-rod bearing cap.

**INSTALL, CONNECT**

1. New bearing shells with engine oil.
2. Con-rod bearing cap.

**TORQUE — ANGLE METHOD**

1. Con-rod bearing cap to con-rod — 35 Nm. + 45° + 15°. Use new bolts.
2. Install oil pan.

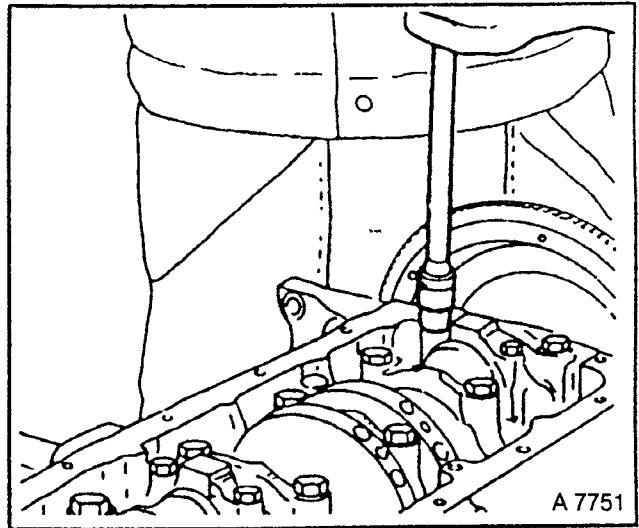


Fig. 466

**Con-Rod — Replace****REMOVE, DISCONNECT**

1. Piston.
2. See "Piston with Con-rod, Remove and Install", page 200.
3. Piston pin retainer — press out piston pin.

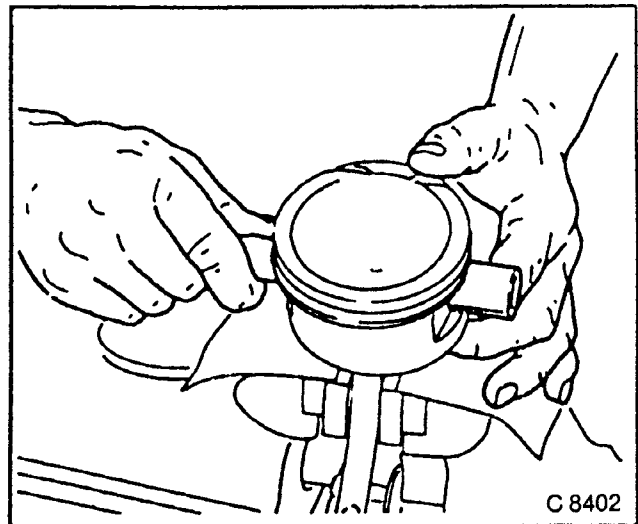


Fig. 467



**ASSEMBLE**

1. Con-rod.
2. Piston.
3. Piston pin — coat lightly with engine oil.
4. New piston pin retainer.

**NOTE:**  
**NOTE INSTALLATION POSITION —**  
**ARROW ON PISTON HEAD POINTS**  
**TOWARDS TIMING SIDE, BEAD ON**  
**CON-ROD TO CLUTCH SIDE OF**  
**ENGINE.**

**INSTALL, CONNECT**

1. Piston with con-rod.

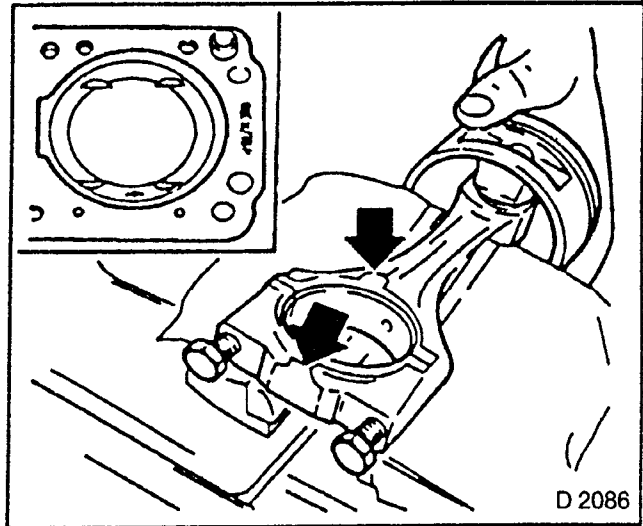


Fig. 468

**Flywheel — Remove and Install****REMOVE, DISCONNECT**

1. Transmission clutch — see operations in Section K.
2. Flywheel — mark installation position.
3. Attach MKM-604-21 (Tox Nut E 20) to fastening bolt of toothed belt drive gear (arrow) and counterhold.

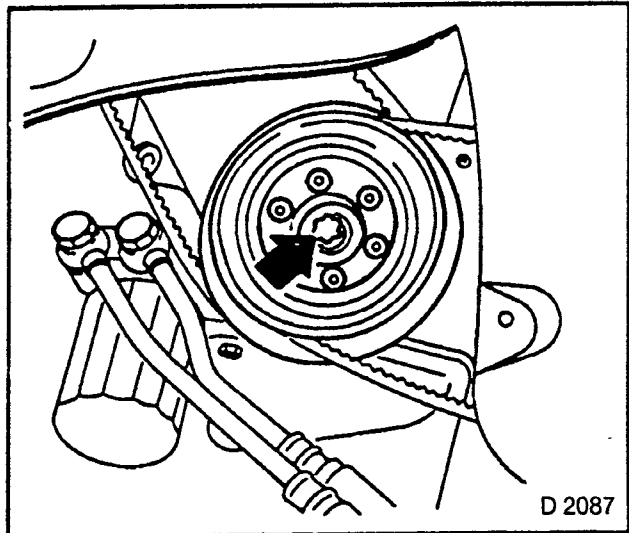


Fig. 469

**TORQUE — ANGLE METHOD**

1. Flywheel to crankshaft — 65 Nm. + 30° to 45°. Use new bolts.
2. When installing, attach MKM-604-21 (Torx Nut E 20) to fastening bolt of toothed belt drive gear and counterhold.
3. Install guide sleeve.
4. Thrust bearing and clutch. See operations in Section K.

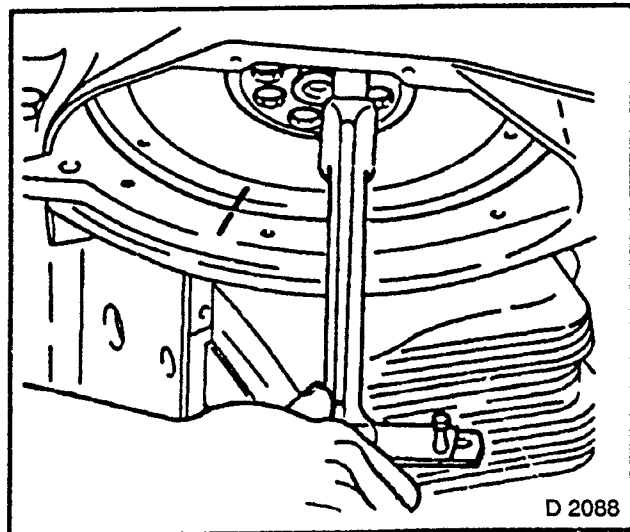


Fig. 470

## Pot Flyweel — Remove and Install

### REMOVE, DISCONNECT

1. Transmission clutch — see operations in Section K.
2. Pot flywheel — mark installation position.
3. Lock pot flywheel with KM-652.

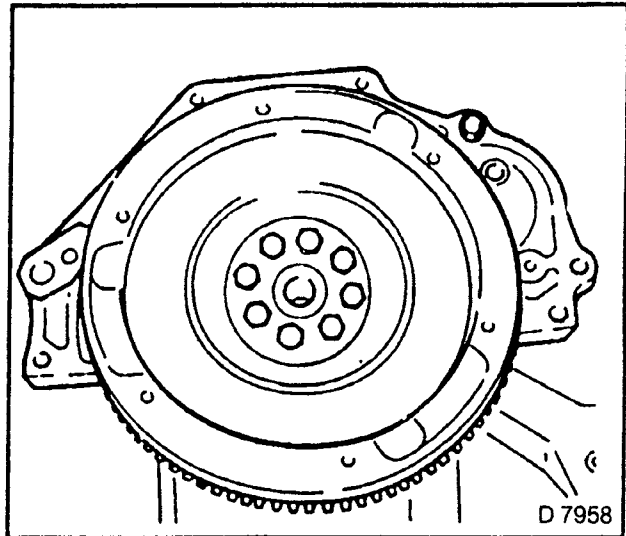


Fig. 471

4. Lock pot flywheel with KM-652.

### TORQUE — ANGLE METHOD

1. Pot flywheel to crankshaft — 65 Nm + 30° + 15°. Use new bolts.

### INSTALL, CONNECT

1. Transmission clutch — see operations in Section K.

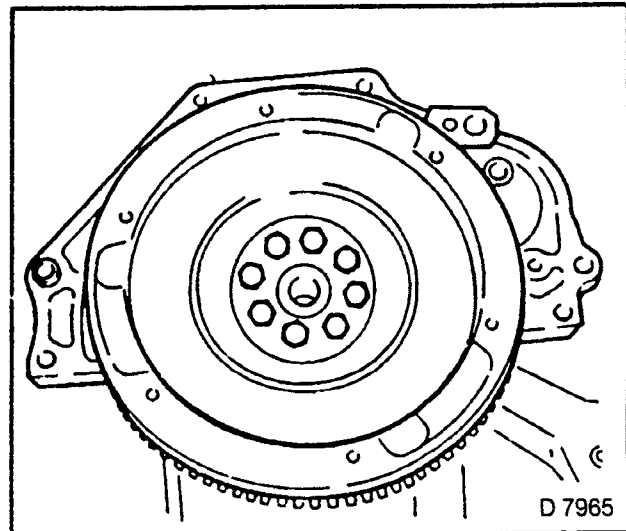


Fig. 472

## Cylinder Block — Check for Plane Surface

### CLEAN

Cylinder block sealing surfaces.

### INSPECT

1. Cylinder block sealing surfaces' length and breadth for bending and also diagonals for warping.
2. Use aligning ruler and feeler gauge.

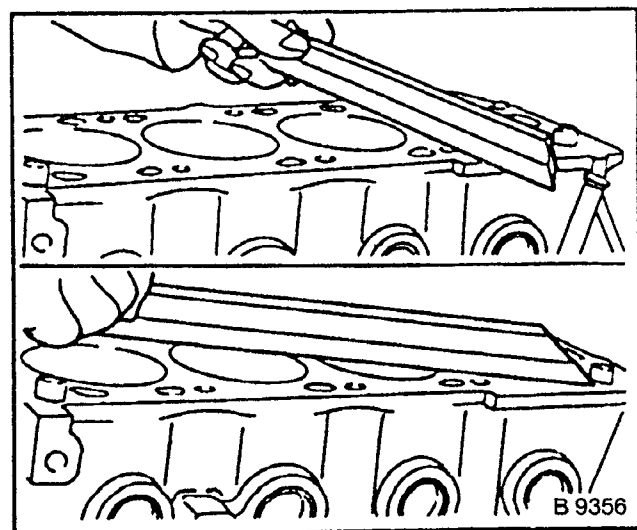


Fig. 473

**NOTE:**  
**AFTER SURFACE GRINDING,**  
**CHECK PISTON PROJECTION.**  
**PERMISSIBLE PISTON**  
**PROJECTION: 0,40 MM.**

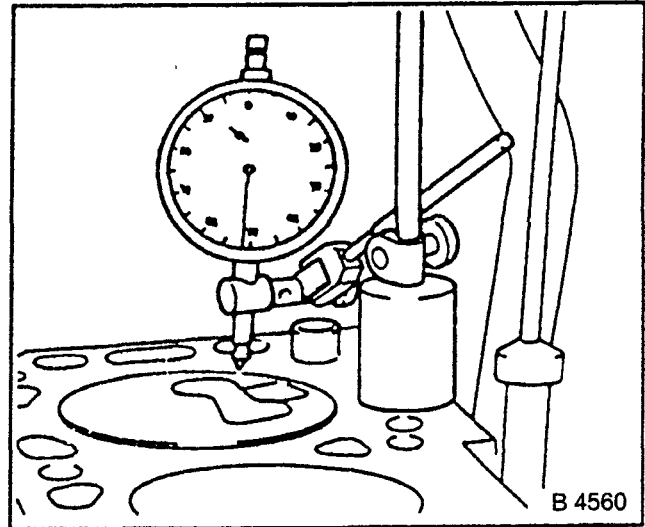


Fig. 474

**RECOMMENDED TORQUE VALUES — OIL CIRCUIT**

|  | Nm                               |
|--|----------------------------------|
| Adapter (threaded piece) of oil cooler to oil pump .....                         | 23 <sup>3)</sup>                 |
| Closure bolt (safety valve) to oil pump .....                                    | 30                               |
| Closure bolt to oil thermostat housing (M 20) .....                              | 20 + 60° + 90° <sup>1)</sup>     |
| Front toothed belt cover to cylinder head, intermediate piece and oil pump ..... | 8                                |
| Oil cooler lines to adapter .....  | 30                               |
| Oil cooler lines to oil cooler .....   | 30                               |
| Oil drain plug to oil pan .....  | 45                               |
| Oil feed line to cylinder block screw fitting .....                              | 20 <sup>3)</sup>                 |
| Oil feed line to turbocharger .....  | 12 <sup>3)</sup>                 |
| Oil filter cartridge to oil pump .....   | 15                               |
| Oil intake pipe to oil pump .....  | 8 <sup>3)</sup>                  |
| Oil pan to cylinder block .....  | 15 <sup>3)4)</sup>               |
| Oil pump cover to oil pump .....   | 6                                |
| Oil pump to cylinder block .....   | 6                                |
| Oil temperature switch to cylinder block .....                                   | 30                               |
| Rear toothed belt cover to cylinder block .....                                  | 6                                |
| Toothed belt drive gear to crankshaft .....                                      | 250 + 40° to 50° <sup>1)3)</sup> |
| Wheel bolts to front wheel hub .....   | 110                              |

1) Use new bolt(s)  
 2) Insert bolt with grease.  
 3) Insert bolts with Locking Compound Loctite 242.  
 4) Max. installation time 10 min.  
 5) C 20 LET only.

## By-pass Valve — Replace REMOVE, DISCONNECT

1. Flap of engine compartment cover for oil filter cartridge.
2. Oil cooler lines from adapter.
3. Oil filter cartridge with commercially available remover.
4. Threaded rod.
5. Remove adapter.

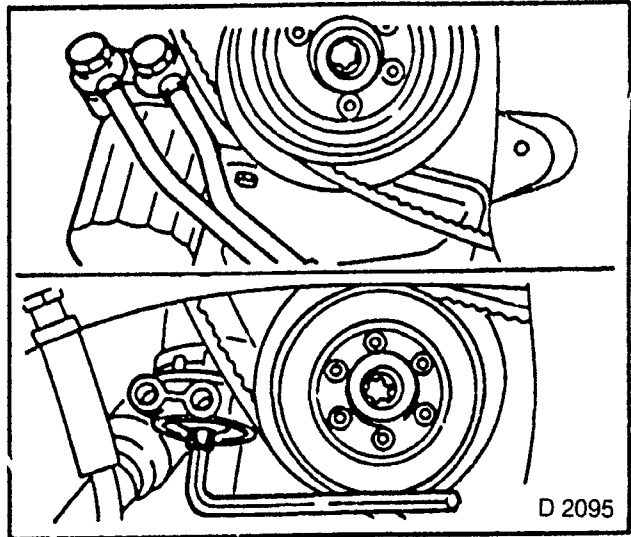


Fig. 475

## REMOVE, DISCONNECT

1. Bypass valve.
2. Cut thread in sealing washer with screw tap M 10 (3rd stage).
3. Turn in M 10 bolt.
4. Pull bypass valve out of seating.

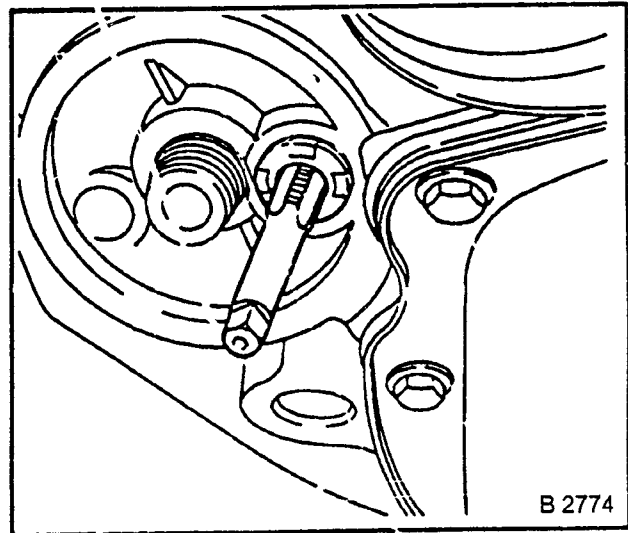


Fig. 476

## INSTALL, CONNECT

1. Bypass valve — with drift ( $\phi$  approximately 15 mm) to stop.
2. Adapter with new seal ring — threaded rod — new oil filter cartridge — fill with engine oil.
3. Oil cooler lines to adapter.
4. Engine compartment cover flap (if present) for oil filter cartridge.

## TIGHTEN (TORQUE)

1. Adapter (threaded rod) to oil pump — 23 Nm.  
Insert with Locking Compound Loctite 242.
2. Oil filter cartridge to oil pump — 15 Nm.
3. Oil cooler lines to adapter — 30 Nm.

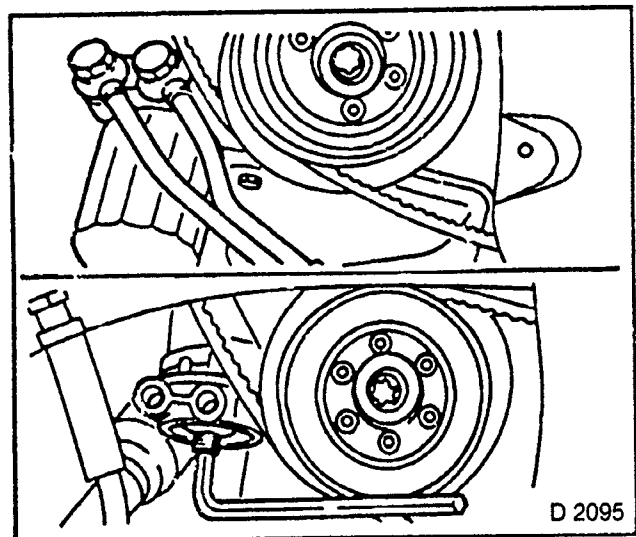


Fig. 477

## INSPECT

1. Engine oil level.

## Oil Pump — Remove and Install

### REMOVE, DISCONNECT

1. Right front wheel.
  2. Toothed belt — see “Toothed Belt, Replace”, page 168.
  3. Toothed belt tension roller.
  4. Toothed belt guide roller.
  5. Camshaft sprockets.
  6. Rear toothed belt cover.
- 
7. Toothed belt drive pinion.
  8. Mount MKM-604-21 (Torx Nut E 20) and Holding Wrench KM-662-A, as shown in illustration — observe manufacturer's instructions.
  9. If necessary, mount Remover KM-210-A with KM-516 and KM-647.
  10. Remove toothed belt drive gear.

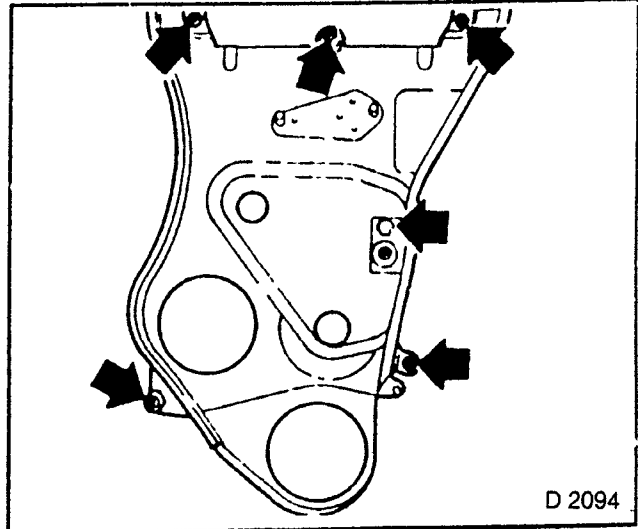


Fig 478

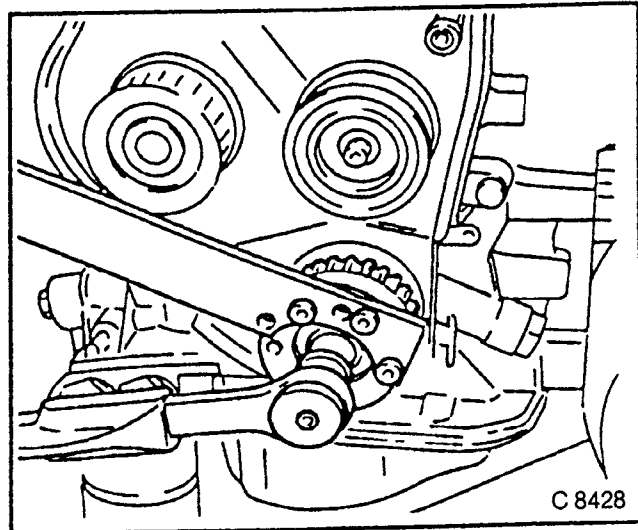


Fig. 479

### REMOVE, DISCONNECT

1. Spacing ring (1) from crankshaft journal.
2. Oil pan.
3. Oil pressure switch wiring plug.
4. Oil cooler lines from adapter.
5. Oil filter cartridge with commercially available remover.
6. Oil pump (arrows) from cylinder block.
7. When replacing oil pump modify adapter for oil cooler with new seal ring and oil pressure switch.
8. Overhaul oil pump.

### CLEAN

Sealing surfaces.

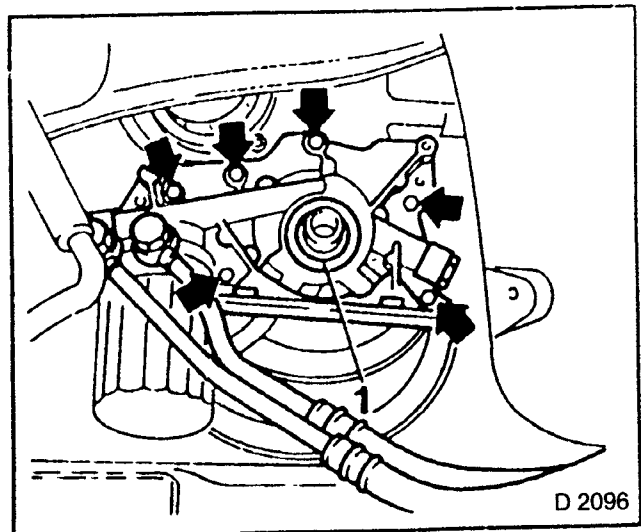
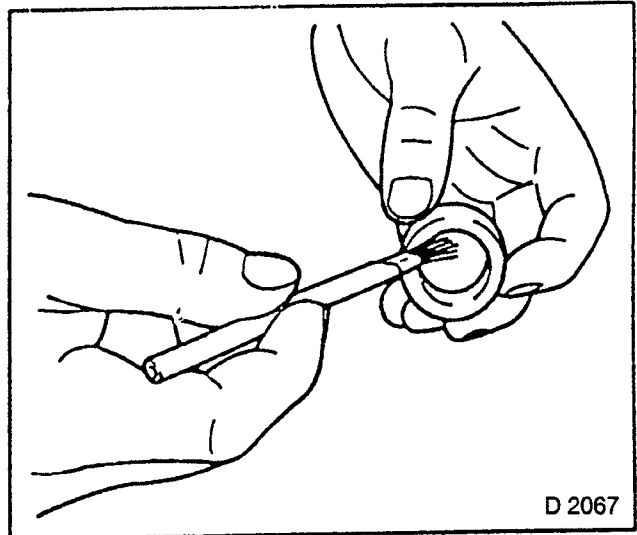


Fig. 480

**INSTALL, CONNECT**

1. Oil pump with new seal ring (use KM-693 — coat seal lips with protective grease) and gasket.
2. New oil filter cartridge (fill with engine oil).
3. Oil cooler leads.
4. Wiring plug.
5. Oil pressure switch.
6. Oil pan — See "Gasket Oil Pan, Replace", page 208.
7. Spacing ring onto crankshaft journal — coat fore part with Sealing Compound Locktite 515 flexible gasket or equivalent.

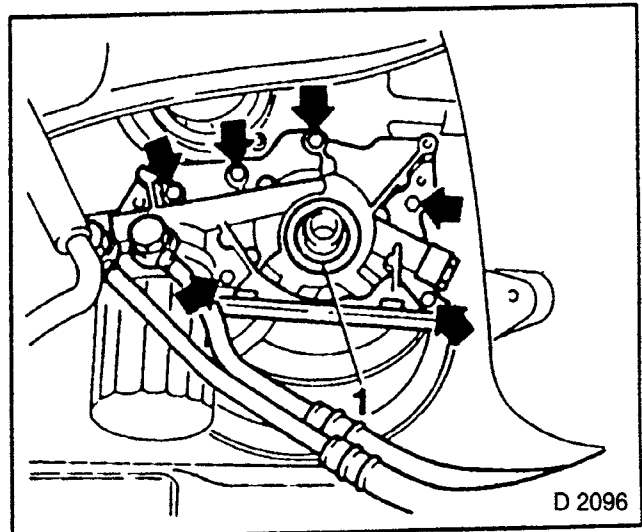


D 2067

Fig. 481

**TIGHTEN (TORQUE)**

1. Oil pump to cylinder block — 6 Nm.
2. Oil filter cartridge to oil pump — 15 Nm.
3. Oil cooler leads to adapter — 30 Nm.



D 2096

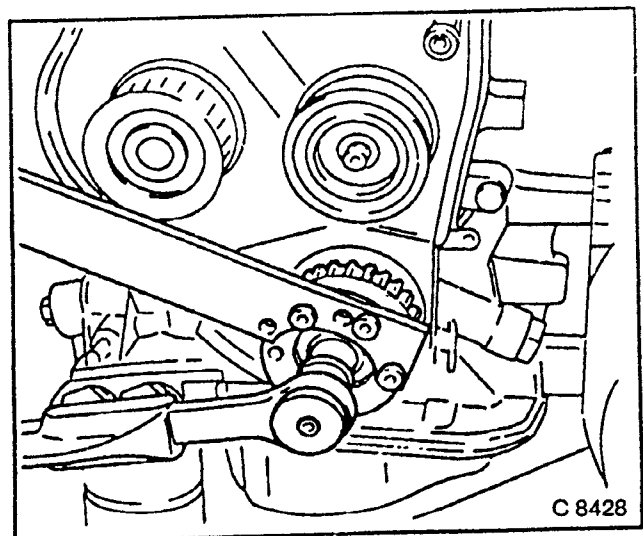
Fig. 482

**TORQUE — ANGLE METHOD**

1. Toothed belt drive pinion to crankshaft — 250 Nm + 40° to 50°. Use new bolt.

**NOTE:****INSERT FASTENING BOLT OF TOOTHED BELT DRIVE PINION WITH GREASE.**

2. When installing toothed belt drive pinion, mount MKM-604-21 (Torx Nut E 20) and Holding Wrench KM-662-A, as illustrated — observe manufacturer's instructions.



C 8428

Fig. 483

**INSTALL, CONNECT**

1. Rear toothed belt cover — 6 Nm.
2. Camshaft sprockets.
3. Toothed belt guide roller.
4. Toothed belt tension roller.
5. Toothed belt.
6. Right front wheel — 110 Nm.

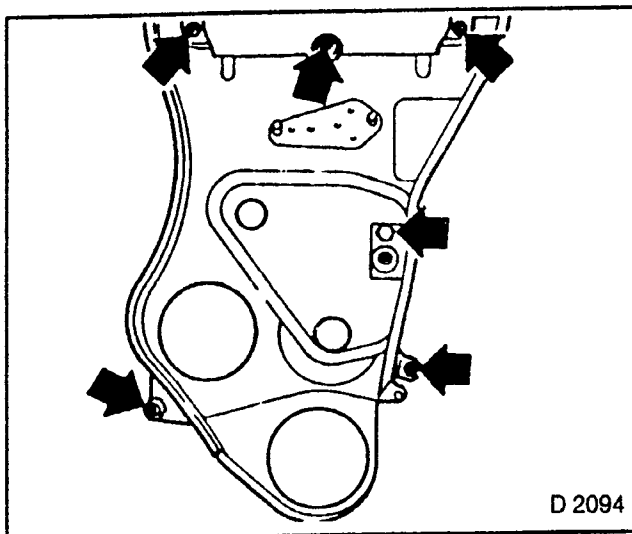


Fig. 484

D 2094

**Gasket — Oil Pan — Replace****REMOVE, DISCONNECT**

1. Performance header.
2. Wiring plug for dynamic oil level check.
3. Transmission cover.
4. Place collecting basin underneath.
5. Oil drain plug — drain engine oil.
6. Install oil drain plug — 45 Nm.

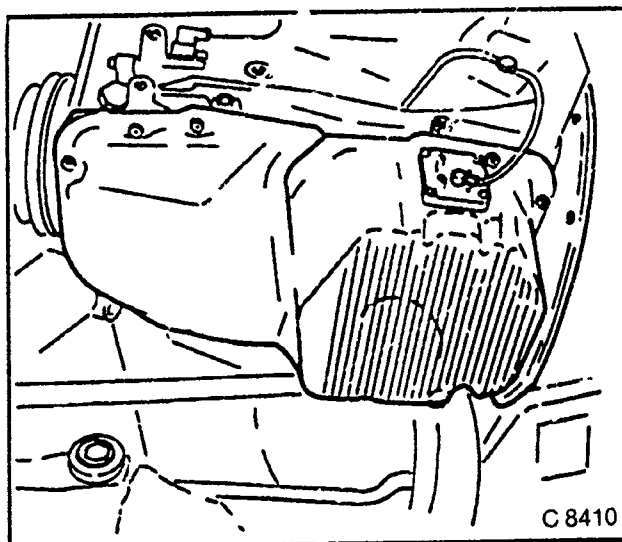


Fig. 485

C 8410

**REMOVE, DISCONNECT**

1. Oil pan.
2. Oil intake tube.
3. Oil intake tube bracket.
4. Baffle plate.

**CLEAN**

Sealing surfaces.

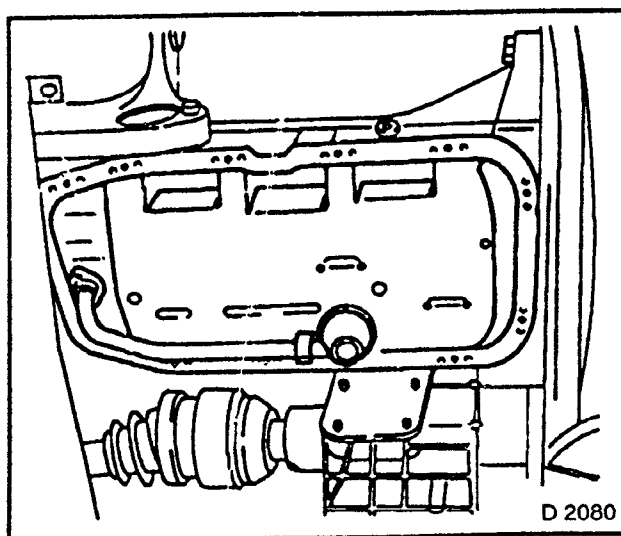


Fig. 486

D 2080

Coat joins with Sealing Compound  
Locktite 242.  
Install cork seal.

**NOTE:**

**CHECK THAT ALL SPACING RINGS  
ARE PRESENT.**

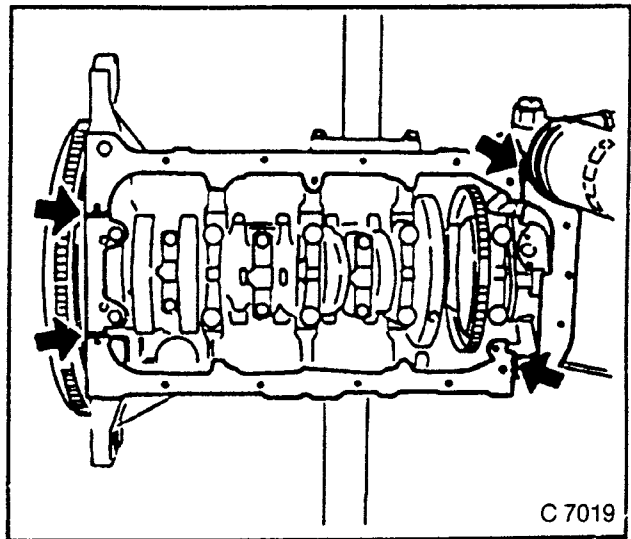


Fig. 487

**INSTALL Baffle PLATE**

**TIGHTEN (TORQUE)**

1. Oil intake tube bracket to cylinder block — 6 Nm.
2. Oil intake tube with new seal ring to oil pump — 8 Nm.  
Insert bolts with Locking Compound  
Locktite 242.

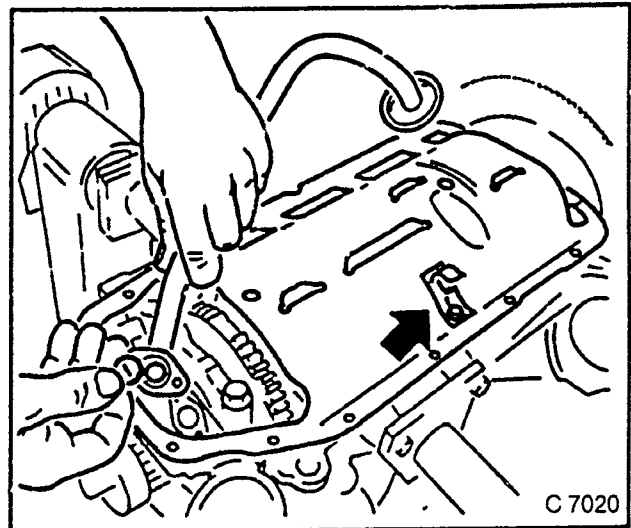


Fig. 488

**INSTALL SECOND CORK SEAL**

**NOTE:**

**CHECK THAT ALL SPACING RINGS  
ARE PRESENT.**

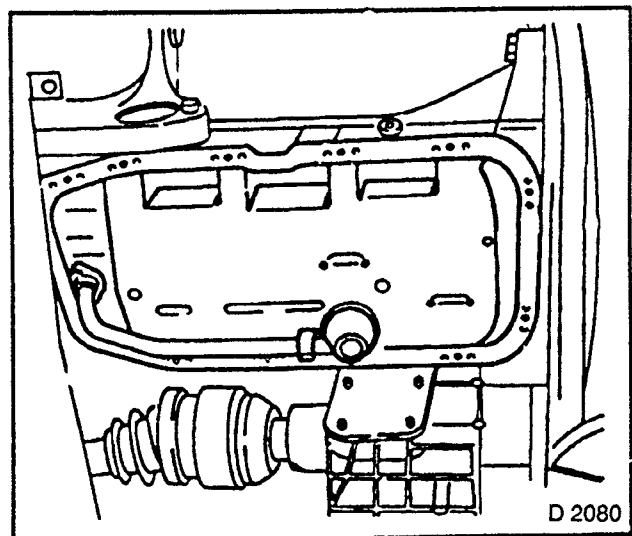


Fig. 489



**INSTALL, CONNECT**

1. Oil pan — 15 Nm. maximum installation time fifteen minutes.
2. Install bolts with Locking Compound Locktite 242.
3. Transmission cover.
4. Wiring plug for dynamic oil level check.
5. Performance header.
6. Top up engine oil to marking "MAX" on oil dipstick.

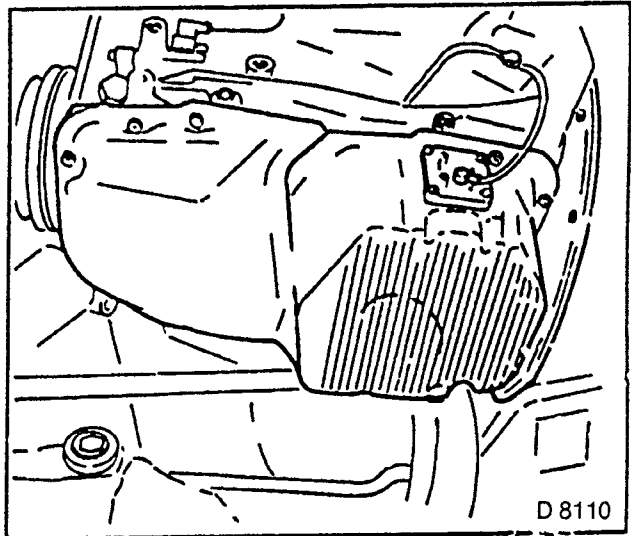


Fig. 490

**Thermostat — Replace  
REMOVE, DISCONNECT**

1. Engine compartment cover.
2. Closure plug.
3. Seal ring.
4. Spring.
5. Piston.

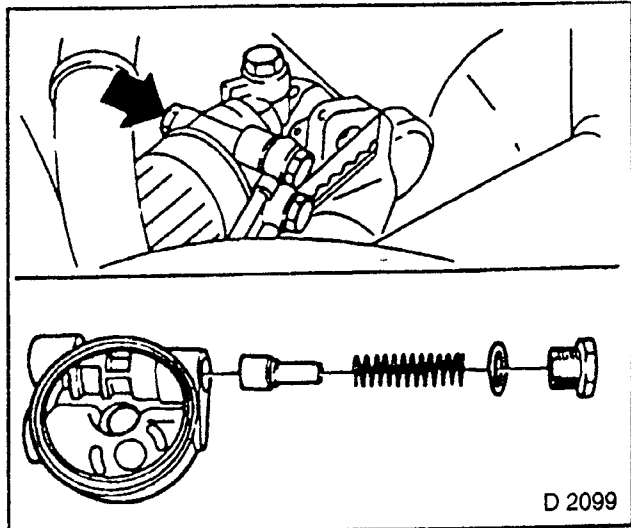


Fig. 491

**INSTALL, CONNECT**

1. Removed components in order. Shown Fig. 454.
2. Engine compartment cover.

**TORQUE — ANGLE METHOD**

1. Closure plug (M20) to thermostat housing — 20 Nm + 60° + 30°. Use new bolts.

# Oil Pump Safety Valve — Replace

## REMOVE, DISCONNECT

1. Engine compartment cover.
2. Closure plug.
3. Seal ring.
4. Spring.
5. Piston.

## INSTALL, CONNECT

1. Removed components in order. Shown Fig. 491.
2. Engine compartment cover.

## TIGHTEN (TORQUE)

1. Closure plug to oil pump — 30 Nm.

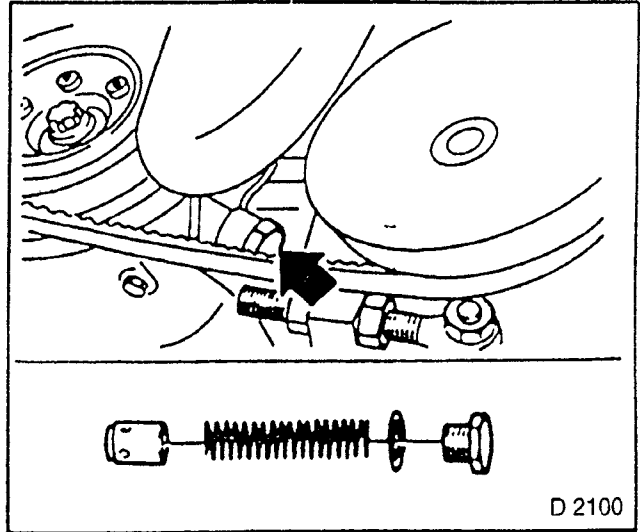


Fig. 492

# Cooling System

## RECOMMENDED TORQUE VALUES

|  | Nm                                 |
|--|------------------------------------|
| Camshaft sprocket to camshaft .....  | 50 + 60° to 75° <sup>1)</sup>      |
| Cover plate to cylinder head (M 6 bolts) .....                               | 9                                  |
| Cover plate to cylinder head (M 8 nuts) .....                                | 22 <sup>1)</sup>                   |
| Cover to throttle valve manifold .....                                       | 5 <sup>2)</sup>                    |
| Front toothed belt cover to cylinder head, intermediate piece and oil pump . | 8                                  |
| Guide pulley to cylinder block .....   | 25 + 45° to max. 60° <sup>3)</sup> |
| Rear toothed belt cover to cylinder block .....                              | 6                                  |
| Tension roller to cylinder block .....                                       | 25 + 45° to max 60° <sup>3)</sup>  |
| Thermostat housing to cylinder head .....                                    | 15                                 |
| Water outlet connection to thermostat housing .....                          | 8                                  |
| Water pump to cylinder block .....   | 25                                 |
| Camshaft housing cover to camshaft housing .....                             | 8                                  |
| Crankshaft pulley to toothed belt drive gear .....                           | 20                                 |
| Temperature sensor to thermostat housing .....                               | 11                                 |

1) Not present on C 20 LET  
 2) C 20 LET only  
 3) Use new bolt(s)

## Seal Ring — Thermostat Housing/Cylinder Head — Replace

### REMOVE, DISCONNECT

1. Engine compartment cover.
2. Lower hose (arrow) from radiator — collect coolant.
3. Upper hose from thermostat housing.
4. Cover plate for fantail manifold from cylinder head.

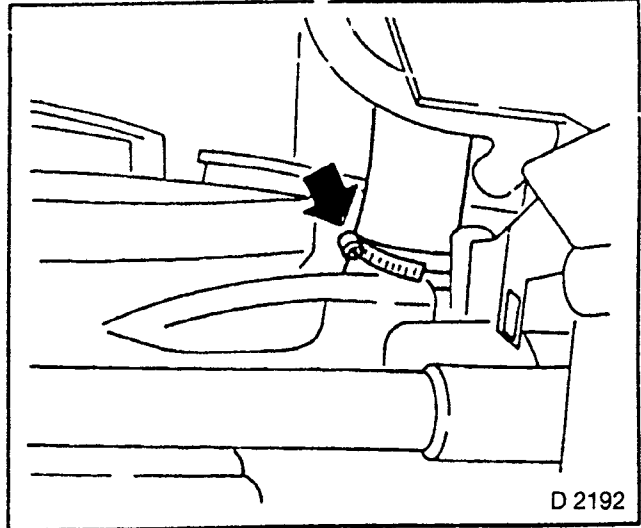


Fig. 493

### REMOVE, DISCONNECT

1. Wiring plug (arrows) from thermostat housing.
2. Thermostat housing from cylinder head.

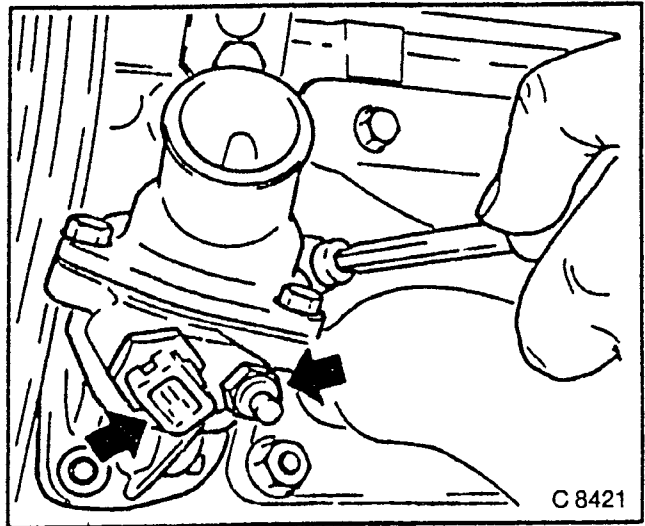


Fig. 494

3. Remove seal ring.

### CLEAN

Sealing surfaces.

### INSTALL, CONNECT

1. New seal ring.
2. Thermostat housing.
3. Wiring plug.
4. Cover plate.
5. Upper and lower hoses.
6. Engine compartment cover.

### TIGHTEN (TORQUE)

1. Thermostat housing to cylinder head — 15 Nm.
2. Cover plate to cylinder head (bolt M6) — 9 Nm.
3. Cover plate to cylinder head (nut M8) — 22 Nm.
4. Top up and bleed cooling system.

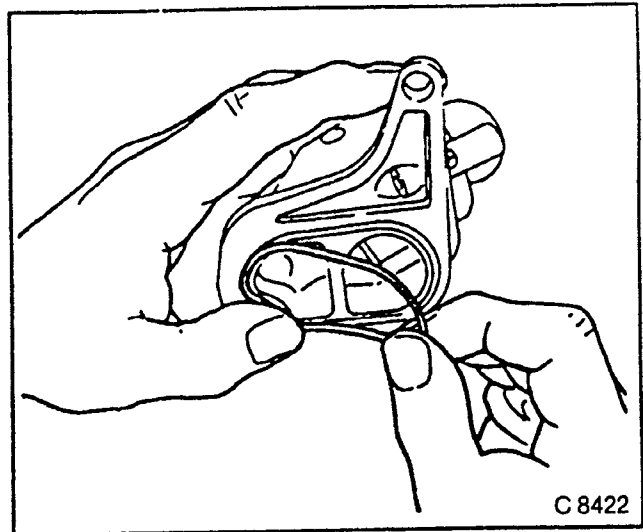


Fig. 495

## Cooling System — Top up and Bleed

**NOTE:**  
USE OPEL/VAUXHALL RADIATOR  
ANTI-FREEZE (SABS 1251)

### REMOVE, DISCONNECT

1. Allen bolt.
2. Top up coolant in compensation tank, until it escapes without bubbles from mounting bore hole of allen bolt.
3. Insert allen bolt with Sealing Compound Loctite 242.
4. Top up coolant to marking "KALT" in compensation tank.
5. Close cooling system and allow engine to run warm until thermostat opens. (approximately 92°C/198°F coolant temperature).

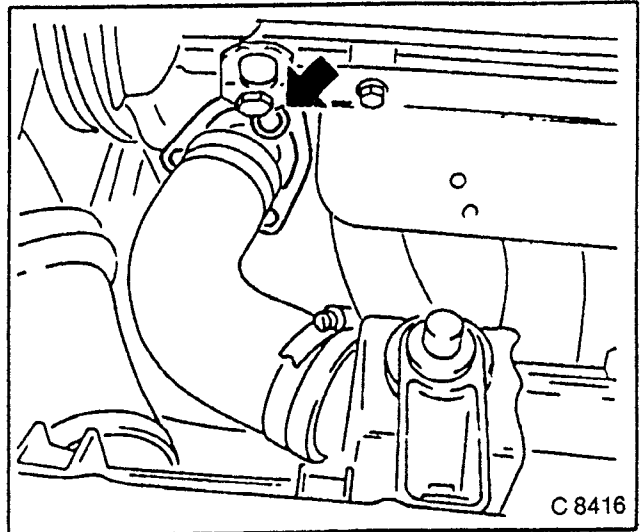


Fig. 496

### INSPECT

1. Coolant level.
2. Allow engine to cool.
3. Top up coolant to marking "KALT" in compensation tank if necessary.

## Coolant Temperature — Measure with Closed Cooling System

### INSTALL, CONNECT

1. Temperature Gauge 17 57 230 (90 141 985) between coolant hose and heating connection pipe in cylinder head. Observe manufacturer's instructions.

### MEASURE

1. Coolant temperature — operating temperature approximately 80°C/176°F.

### REMOVE, DISCONNECT

1. Temperature gauge.

### INSTALL, CONNECT

1. Coolant hose.
2. Top up and bleed cooling system.

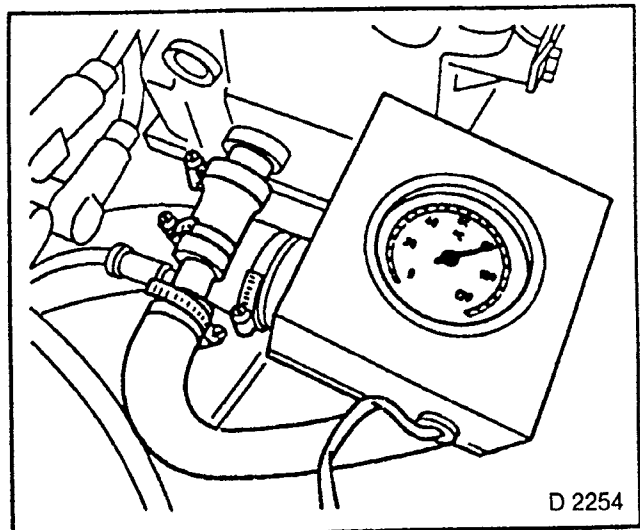


Fig. 497

## Thermostat — Replace

### REMOVE, DISCONNECT

1. Engine compartment cover.
2. Lower hose bend from radiator — collect coolant.
3. Upper hose bend from water outlet connection.
4. Water outlet connection with thermostat from thermostat housing.
5. Remove seal ring.

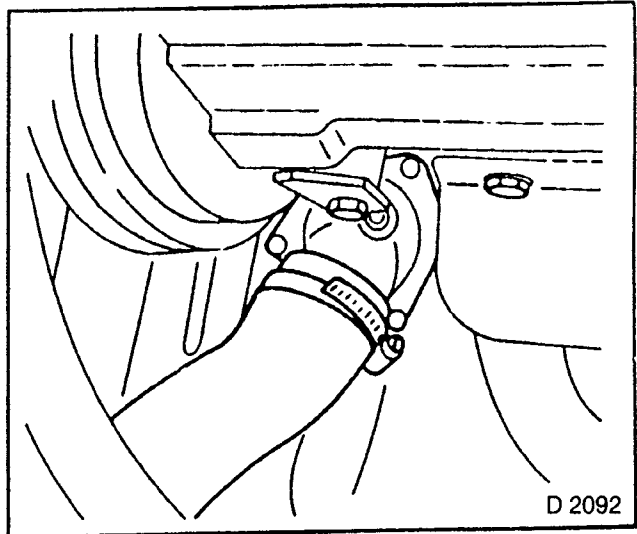


Fig. 498

### CLEAN

Sealing surfaces

### INSTALL, CONNECT

1. New seal ring.
2. Water outlet connection with thermostat to thermostat housing — 8 Nm.
3. Upper and lower hose bends.
4. Engine compartment cover.
5. Top up and bleed cooling system.

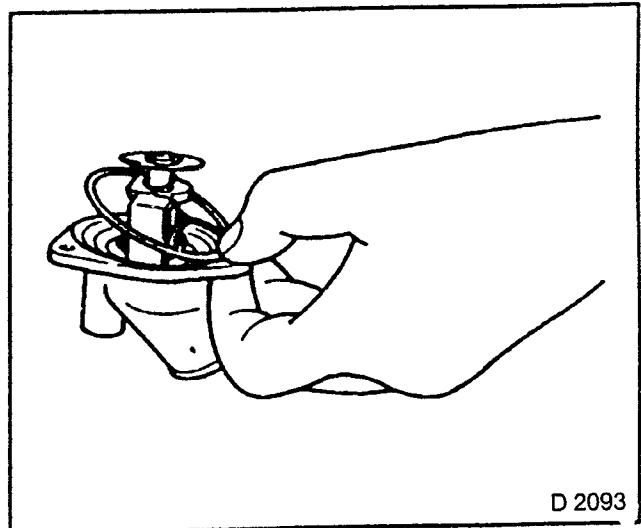


Fig. 499

## Water Pump — Remove and Install

### REMOVE, DISCONNECT

1. Engine compartment cover.
2. Lower hose bend from radiator — collect coolant.
3. Toothed belt — See "Toothed Belt, Replace", page 168.
4. Toothed belt tension roller.
5. Toothed belt guide roller.
6. Camshaft sprockets.
7. Rear toothed belt cover (arrows).

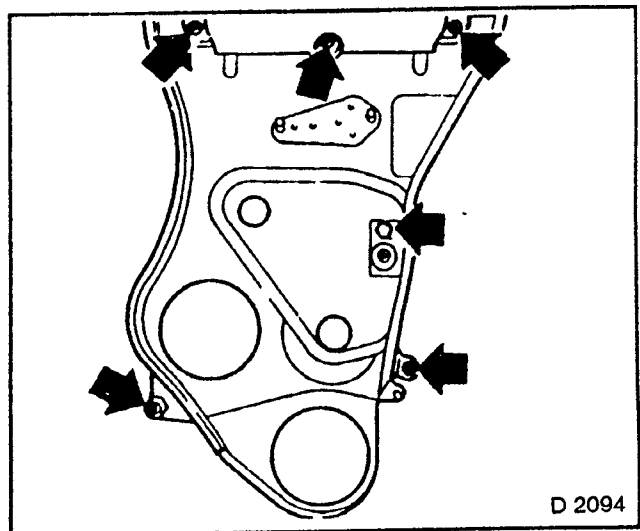


Fig. 500

**REMOVE, DISCONNECT**

Water pump from cylinder block.

**CLEAN**

1. Sealing surfaces.
2. Before installing water pump.
3. Coat sealing surfaces of cylinder block and new seal ring slightly with Silicon Grease B 0400571.

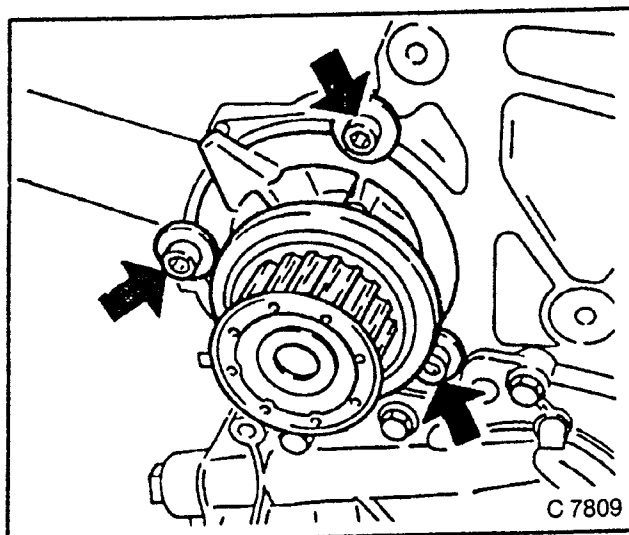


Fig. 501

Insert water pump in cylinder block.

**NOTE:**  
**SPRUES OF WATER PUMP AND CYLINDER BLOCK MUST ALIGN.**

**TIGHTEN (TORQUE)**

1. Water pump to cylinder block — 25 Nm.
2. Pull rear cover up to toothed belt gear of water pump.

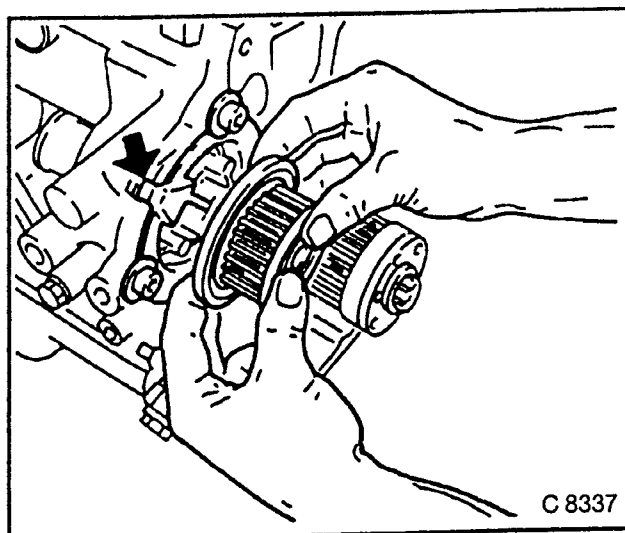


Fig. 502

**INSTALL, CONNECT**

1. Rear toothed belt cover — 6 Nm.
2. Camshaft sprockets.
3. Toothed belt guide roller.
4. Toothed belt tension roller.
5. Toothed belt.
6. Lower hose bend to radiator.
7. Engine compartment cover.
8. Top up and bleed cooling system.

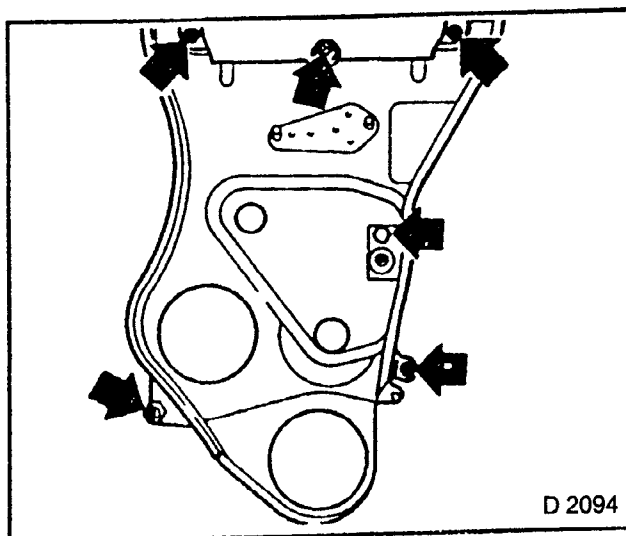


Fig. 503

## Engine Damping Blocks — Engine — Short-Block

### RECOMMENDED TORQUE VALUES

|  | Nm                                 |
|--|------------------------------------|
| Brake servo vacuum line to intake manifold/intake pipe .....                   | 15                                 |
| Clamping bracket to alternator .....   | 25                                 |
| Clamping bracket, alternator to intake manifold/intake pipe .....              | 25                                 |
| Cylinder head cover to cylinder head .....                                     | 8                                  |
| Cylinder head to cylinder block .....  | 25 + 65° + 65° + 65° <sup>1)</sup> |
| Front toothed belt cover to cylinder head, intermediate piece and oil pump ... | 8                                  |
| Guide pulley to cylinder block .....   | 25 + 45° to max. 60° <sup>4)</sup> |
| Ignition cable cover to cylinder head cover .....                              | 8                                  |
| Oil pan to cylinder block .....  | 15 <sup>2)</sup>                   |
| Oil temperature switch to cylinder block .....                                 | 30                                 |
| Right engine damping block to side member .....                                | 65 <sup>3)</sup>                   |
| Shift rod to knurled bolt .....  | 15                                 |
| Spark plug in cylinder head .....  | 25                                 |
| Support to intake manifold and cylinder block .....                            | 25                                 |
| Tension roller to cylinder block .....   | 25 + 45° to max. 60° <sup>4)</sup> |
| Thermostat housing to cylinder head .....                                      | 15                                 |
| Toothed belt drive gear to crankshaft .....                                    | 250 + 40° to 50° <sup>4)</sup>     |
| Water pump to cylinder block .....   | 25                                 |
| Wheel bolts to front wheel hub .....   | 110                                |
| Bracket for power steering pump/AC compressor to cylinder block . . . . .      | 40                                 |
| Bracket, oil intake pipe to cylinder block .....                               | 6                                  |
| Camshaft sprocket to camshaft .....  | 50 + 60° to 75° <sup>4)</sup>      |
| Coolant pipe to cylinder block .....   | 20                                 |
| Crankshaft pulley to toothed belt drive gear .....                             | 20                                 |
| Engine suspension bracket to cylinder block .....                              | 60                                 |
| Exhaust pipe to exhaust diverter manifold .....                                | 12 <sup>1)</sup>                   |
| Inductive pulse pick-up to cylinder block .....                                | 6                                  |
| Intermediate shaft bracket to cylinder block .....                             | 55 <sup>2)</sup>                   |
| Knock sensor to cylinder block .....   | 20                                 |
| Oil cooler lines to adapter .....  | 30                                 |
| Oil drain plug to oil pan .....  | 45                                 |
| Oil filter cartridge to oil pump .....   | 15                                 |
| Oil intake pipe to oil pump .....  | 8 <sup>3)</sup>                    |
| Performance header with cover plate to cylinder head .....                     | 22                                 |
| Rear toothed belt cover to cylinder block .....                                | 6                                  |
| Starter to cylinder block (engine side) .....                                  | 45                                 |
| Transfer box bracket to cylinder block .....                                   | 60                                 |
| Transmission to engine block .....   | 75                                 |
| Engine ventilation flange to cylinder block .....                              | 25                                 |
| Guide roller to cylinder block .....   | 25                                 |
| Inductive pulse pick-up to cylinder block .....                                | 6                                  |
| Oil intake pipe bracket to cylinder block .....                                | 6                                  |

<sup>1)</sup> C 20 LET only

<sup>2)</sup> Vehicles with front wheel drive.

<sup>3)</sup> Use new bolt(s).

<sup>4)</sup> Insert bolts with Locking Compound Loctite 242.

<sup>5)</sup> Maximum installation time 10 minutes.

<sup>6)</sup> Insert bolt with grease.

<sup>7)</sup> After test run, turn bolts a further 30° to 45°.

## Engine with Transmission — Remove and Install (C 20 LET with Pot Flywheel)

### REMOVE, DISCONNECT

1. Ground cable from battery.
2. Disconnect fan motor wiring plug.
3. Fan shroud with fan motor from radiator — remove upwards.
4. Lower hose bends from radiator — collect coolant.

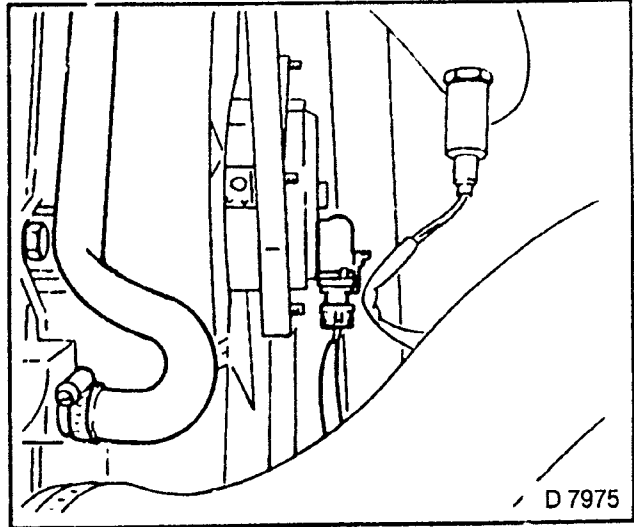


Fig. 504

### REMOVE, DISCONNECT

#### C 20 LET:

1. Air hose (1) — close turbocharger openings.

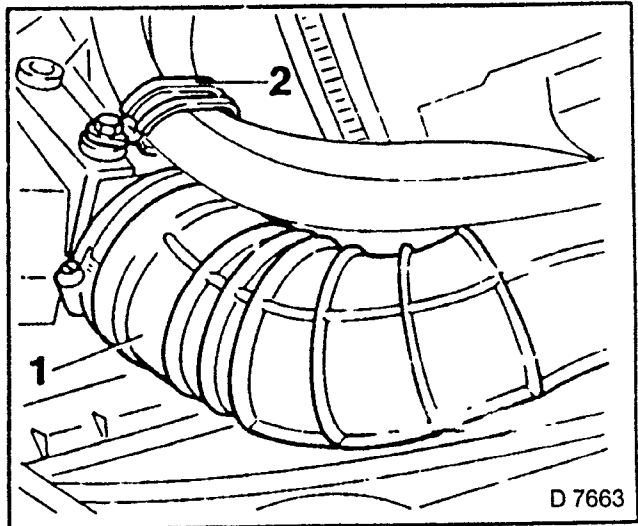


Fig. 505

### REMOVE, DISCONNECT

#### C 20 LET:

1. Wiring plug (1) and hose (2) from charge pressure bypass valve.
2. Disconnect wiring plug (3).
3. Air hose between charge cooler and throttle valve manifold.
4. Vacuum hose between throttle valve housing and control unit.

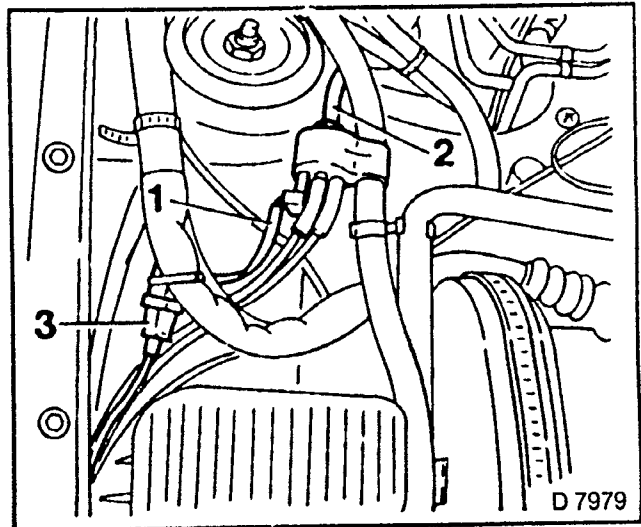


Fig. 506



**REMOVE, DISCONNECT**

- 1. Wiring plug from high voltage distributor.
- 2. High voltage cable from ignition coil.
- 3. Wiring plug (1) from ignition coil control unit.

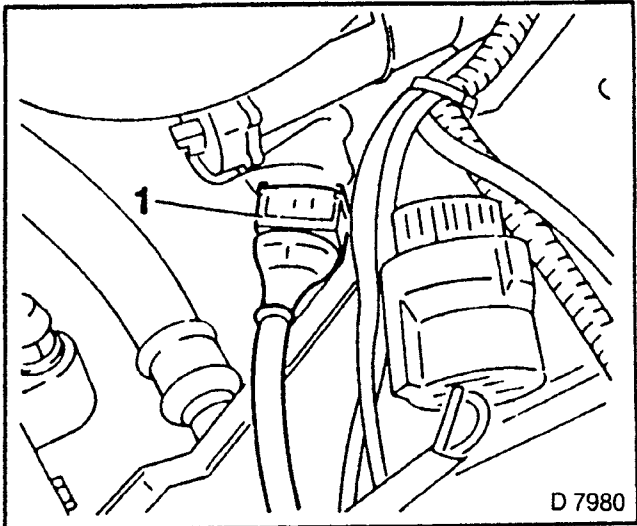


Fig. 507

**REMOVE, DISCONNECT**

- 1. Disconnect engine/body multi-plug (1).
- 2. Disconnect wiring plug (2) for reversing lamps.
- 3. Wiring plug from 1st gear recognition (C 20 LET only).

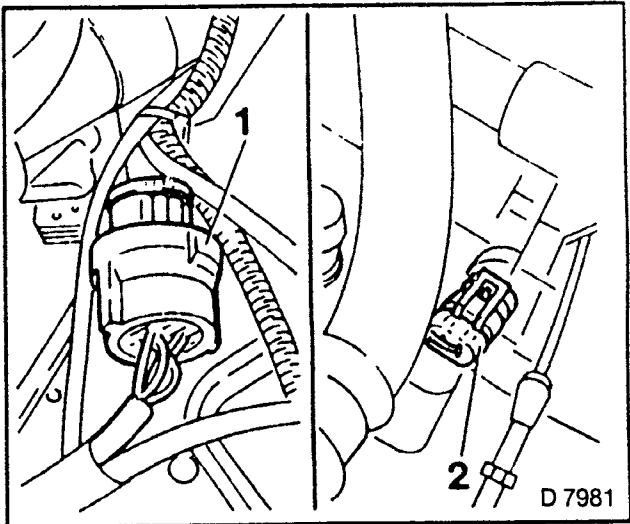


Fig. 508

**REMOVE, DISCONNECT**

- 1. Wiring plug for dynamic oil level check.
- 2. Disconnect wiring plug from oxygen sensor on bulkhead.

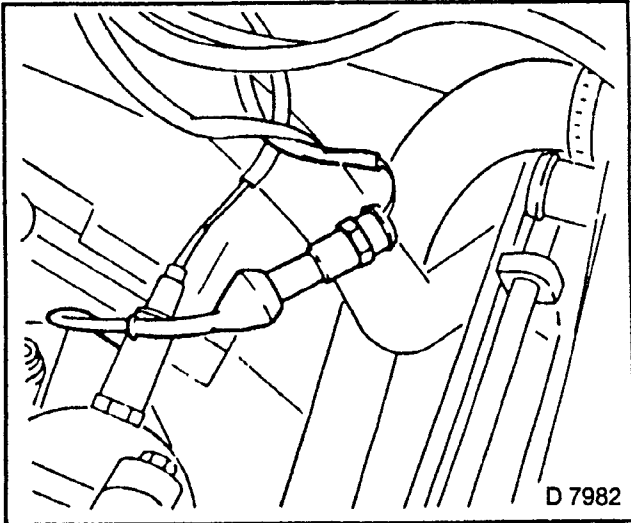


Fig. 509

**REMOVE, DISCONNECT****C 20 LET:**

1. Wiring plug (1) for hot start valve.
2. Wiring plug (2) for intake air temperature sensor.
3. Wiring plug (3) for throttle valve potentiometer.
4. Wiring plug (4) for tank vent valve.
5. Ground connections from fuel distributor pipe.

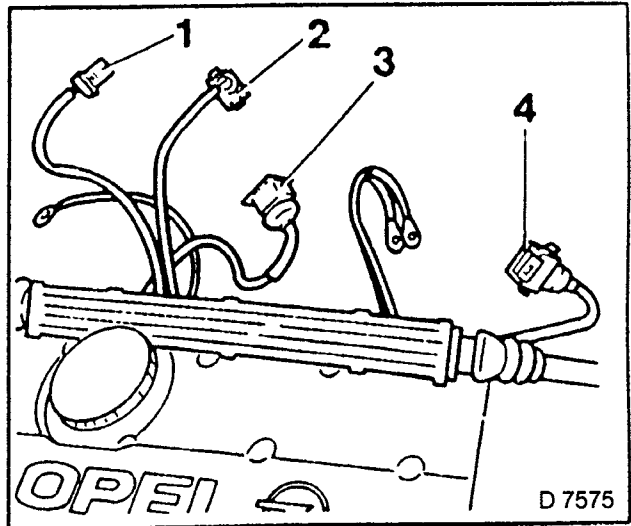


Fig. 510

**REMOVE, DISCONNECT****C 20 XE**

1. Wiring plug (1) from throttle valve switch.
2. Ground connections (2) from fuel distributor pipe.
3. Wiring plug (3) from tank vent valve.

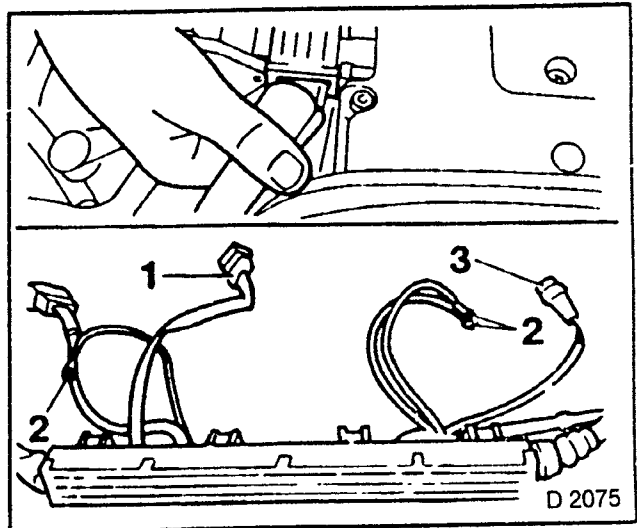


Fig. 511

**REMOVE, DISCONNECT**

1. Bowden cable.
2. Fuel lines — close off with spring clamps.
3. Plug strip from injection valves — for this, pull back retaining clamp on 1st cylinder injection valve.
4. Lay entire wiring harness aside.

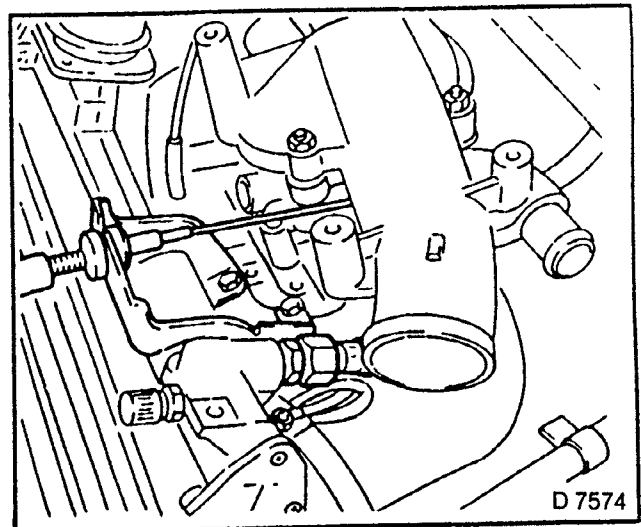
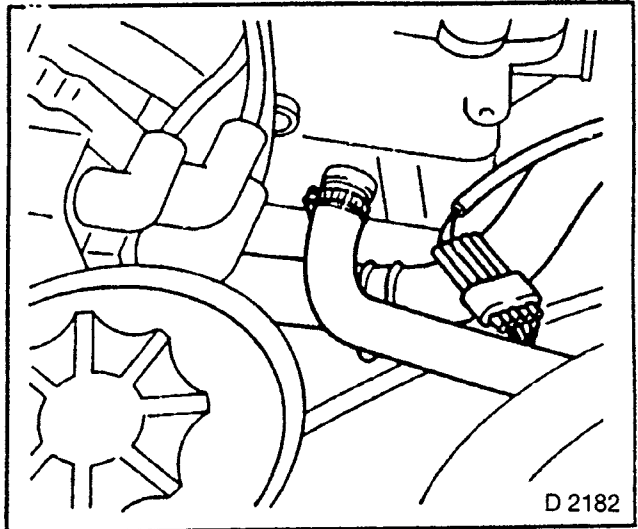


Fig. 512

**REMOVE, DISCONNECT**

- 1. Coolant hose from cylinder head.
- 2. Lower hose bend from coolant pipe.
- 3. Multi-plug.
- 4. Coolant hose from coolant pipe.

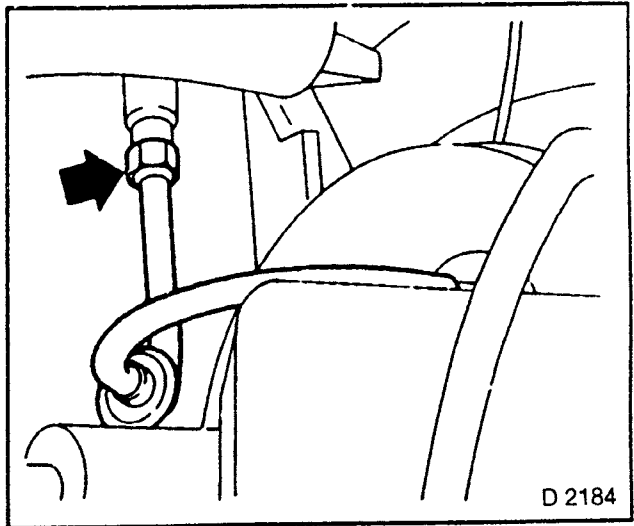


D 2182

Fig. 513

**REMOVE, DISCONNECT**

- 1. Brake servo vacuum line (arrow) from intake manifold.
- 2. Vacuum hose from tank vent valve.
- 3. Clutch cable from clutch release lever.

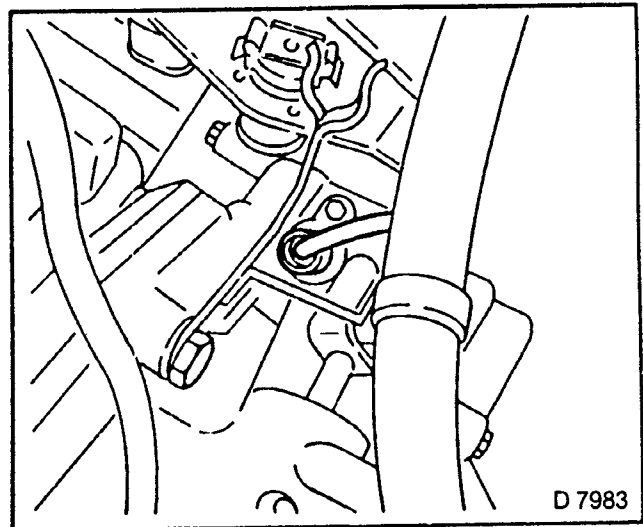


D 2184

Fig. 514

**REMOVE, DISCONNECT**

- 1. Speedometer cable or wiring plug from odometer frequency sensor.
- 2. Shift rod.
- 3. Shift linkage — See Section K.



D 7983

Fig. 515

**REMOVE, DISCONNECT**

- 1. Attach engine to Engine Holder KM-263-B.
- 2. Drive belt for power steering pump.
- 3. Pump assembly bracket from cylinder block.
- 4. Detach assembly to one side.

**NOTE:  
SYSTEM REMAINS CLOSED.**

**REMOVE, DISCONNECT**

1. Oil cooler lines.
2. Oil filter cartridge with commercially available remover — place collecting basin underneath.
3. Exhaust pipe or performance header.

**C 20 LET:**

Lower charge air line.

**REMOVE, DISCONNECT**

1. Front wheels.
2. Ball joints from steering knuckles.
3. Axle shafts.
4. Front axle body — See Section E and K.

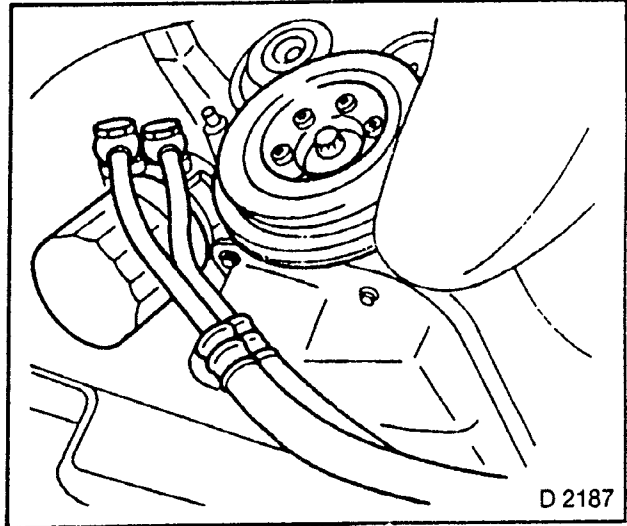


Fig. 516

**REMOVE, DISCONNECT**

1. Support engine with jack.
2. Ground cable from transmission.
3. Engine damping blocks from side members.
4. Remove Engine Holder KM-263-B.
5. Lower engine with transmission.

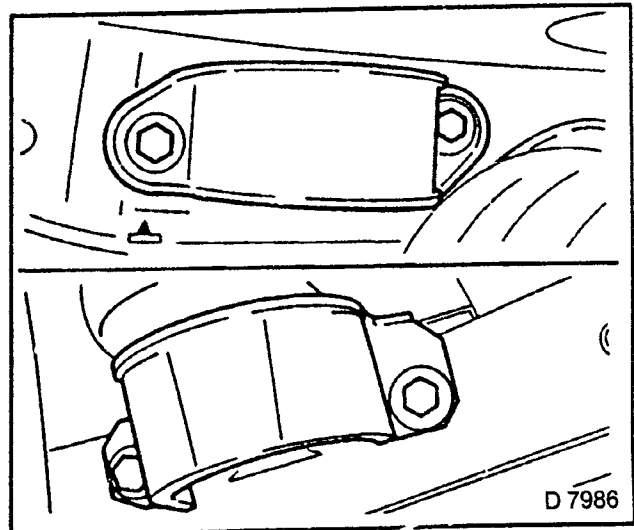


Fig. 517

**INSTALL, CONNECT**

1. Engine with transmission in engine compartment.
2. Attach engine to Engine Holder KM-263-B.

**TIGHTEN (TORQUE)**

1. Engine damping blocks to side members — 65 Nm. Insert bolts with Locking Compound Loctite 242.

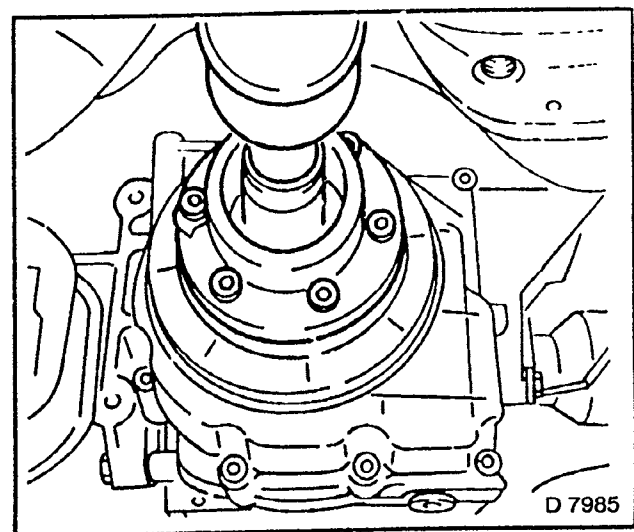


Fig. 518

**INSTALL, CONNECT**

1. Front axle body.
2. Axle shafts.
3. Ball joints in steering knuckles.
4. Front wheels — See Section E and K.

**TIGHTEN (TORQUE)**

Front axle body to underbody

Bolts (1) — 115 Nm.

Bolts (2) — 170 Nm.

**TORQUE — ANGLE METHOD**

Bolts (3 in Fig. 519).— 100 Nm. + 75° to 90°.

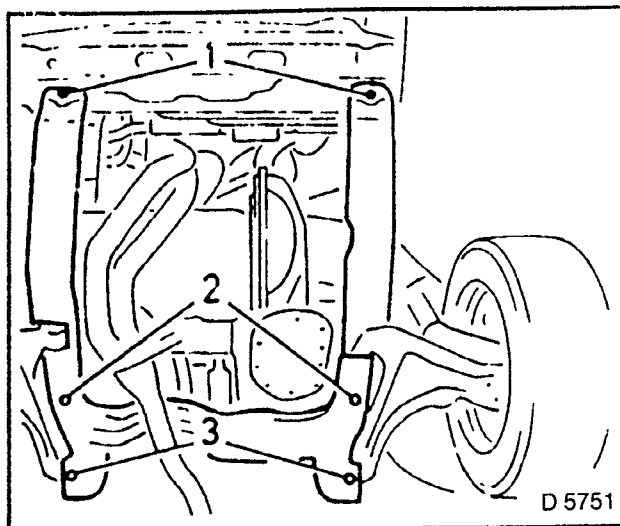


Fig. 519

**TIGHTEN (TORQUE)**

1. Transmission bracket to front axle body (arrows) — 40 Nm.
2. Ball joints to steering knuckles — 70 Nm.
3. Use new retaining clamps and nuts.
4. Front wheels to wheel hubs — 110 Nm.

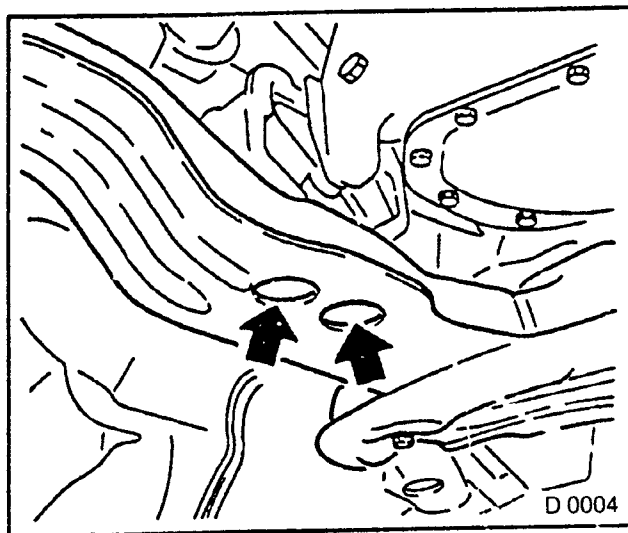


Fig. 520

**INSTALL, CONNECT**

1. Lower charge air line (C 20 LET), exhaust pipe or performance header.
2. Oil filter cartridge (fill with engine oil), oil cooler lines.

**TIGHTEN (TORQUE)**

1. Exhaust pipe to exhaust adapter (C 20 LET) — 12 Nm.
2. Performance header with cover plate to cylinder head — 22 Nm.
3. Oil filter cartridge to oil pump — 15 Nm.
4. Oil cooler lines to adapter — 30 Nm.

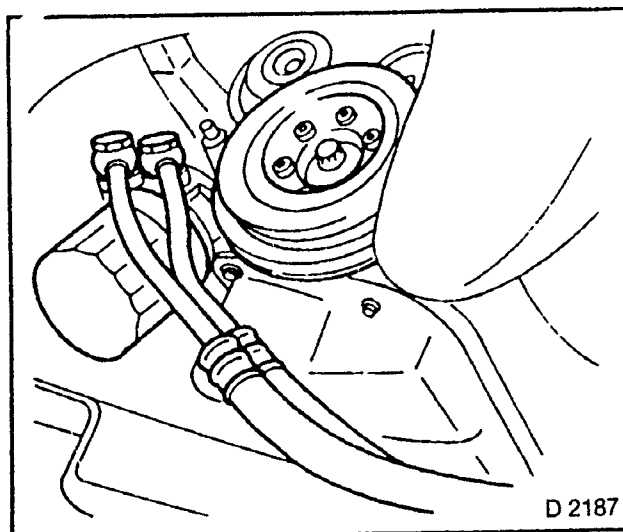


Fig. 521

**TIGHTEN (TORQUE)**

Pump assembly bracket to cylinder block — 40 Nm.

**ADJUST**

Drive belt tension — Section M.

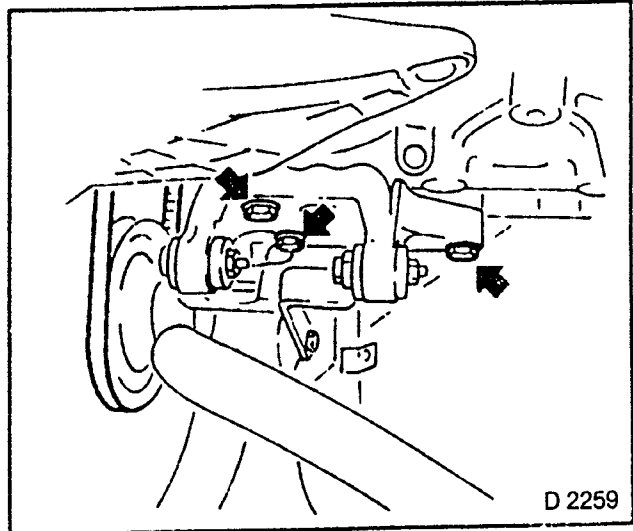


Fig. 522

**INSTALL, CONNECT**

1. Remove Engine Holder KM-263-B.
2. Shift rod, adjustment — See Section K.

**TIGHTEN (TORQUE)**

Shift rod to knurled bolt — 15 Nm.

**INSTALL, CONNECT**

1. Speedometer cable or odometer frequency sensor.
2. Clutch cable.
3. Vacuum hose to tank vent valve.
4. Brake servo vacuum line to intake manifold — 15 Nm.

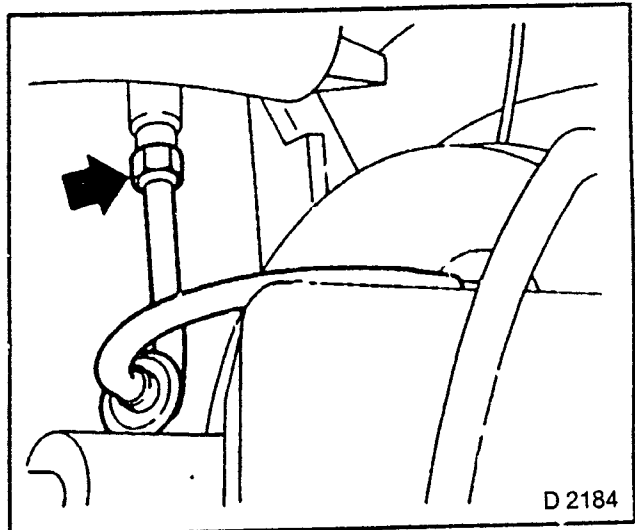


Fig. 523

**INSTALL, CONNECT****C 20 LET:**

1. Injection valves plug strip.
2. Wiring plug (1) for hot start valve.
3. Wiring plug (2) for intake air temperature sensor.
4. Wiring plug (3) for throttle valve potentiometer.
5. Wiring plug (4) for tank vent valve.
6. Ground connections.
7. Note routing of leads.

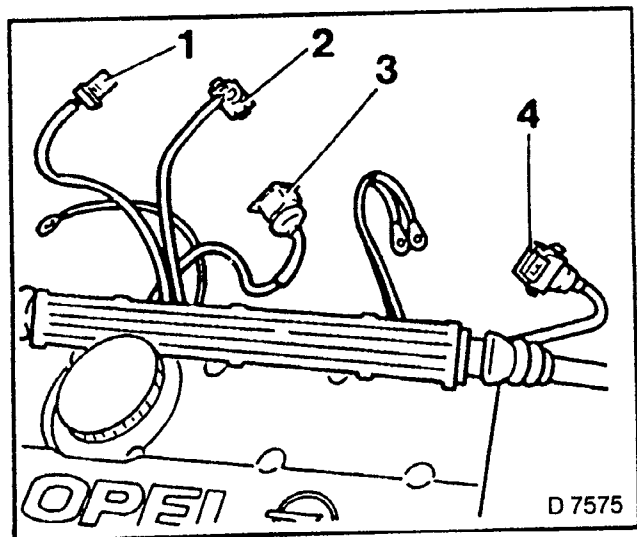


Fig. 524

**INSTALL, CONNECT**

**C 20 XE**

1. Wiring plug (1) to throttle valve switch.
2. Ground connections (2) to fuel distributor pipe.
3. Wiring plug (3) to tank vent valve.
4. Note routing of leads.

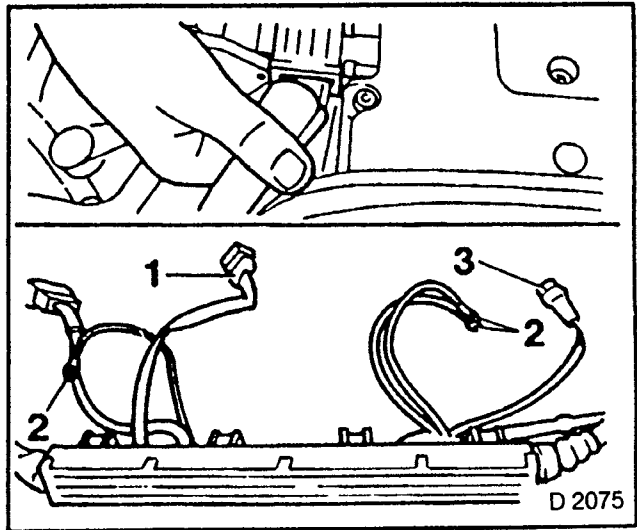


Fig. 525

**INSTALL, CONNECT**

1. Fuel lines.
2. Remove spring clamps.
3. Bowden cable.
4. Coolant hoses to cylinder head.

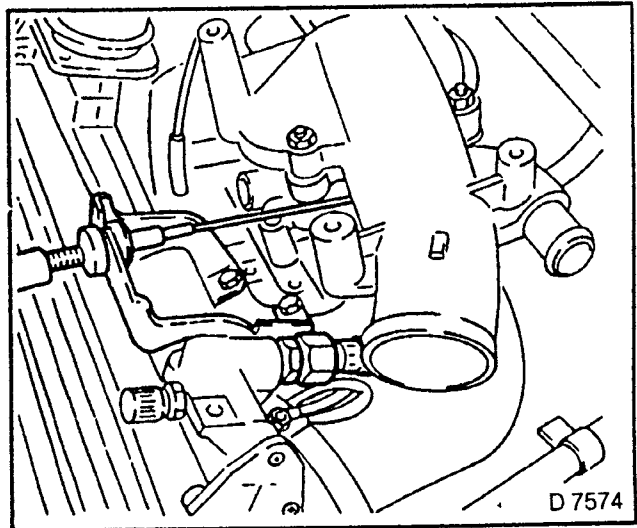


Fig. 526

**INSTALL, CONNECT**

1. Engine/body multi-plug (1).
2. Wiring plug (2) for reversing lamps.
3. Wiring plug for 1st gear recognition (C 20 LET only).

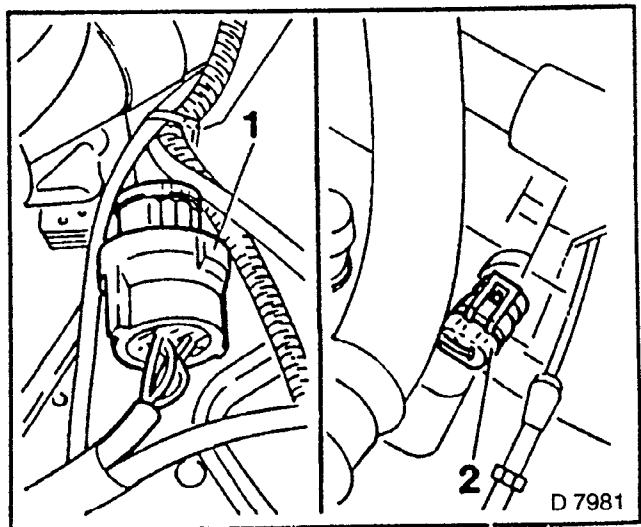


Fig 527

**INSTALL, CONNECT**

1. Wiring plug to high voltage distributor.
2. High voltage cables to ignition coil.
3. Wiring plug to ignition coil control unit.

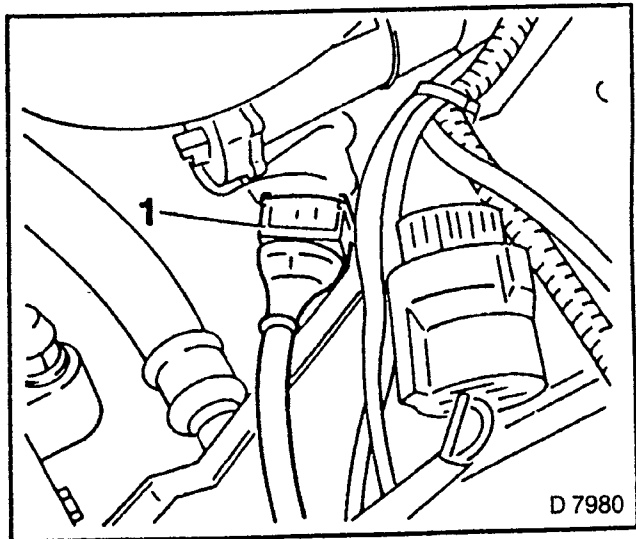


Fig. 528

**INSTALL, CONNECT**

1. Wiring plug to temperature sensor and to temperature pick-up.
2. Upper hose bend to thermostat housing.
3. Coolant hoses to compensation tank.

**IN ADDITION FOR C 20.LET:**

1. Charge cooler air hose — throttle valve manifold.
2. Wiring plug and hose to charge pressure bypass valve.

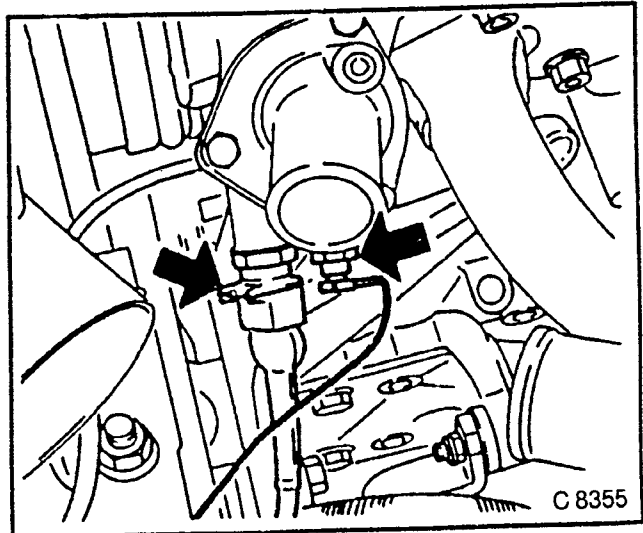


Fig. 529

**INSTALL, CONNECT****20 XE**

1. Air intake hose (1), wiring plug (2) to mass air flow meter.
2. Idle speed adjuster hose (3) to pre-volume chamber.
3. Pre-volume chamber with mass air flow meter (4).
4. Wiring plug (5) for inductive pulse pick-up.

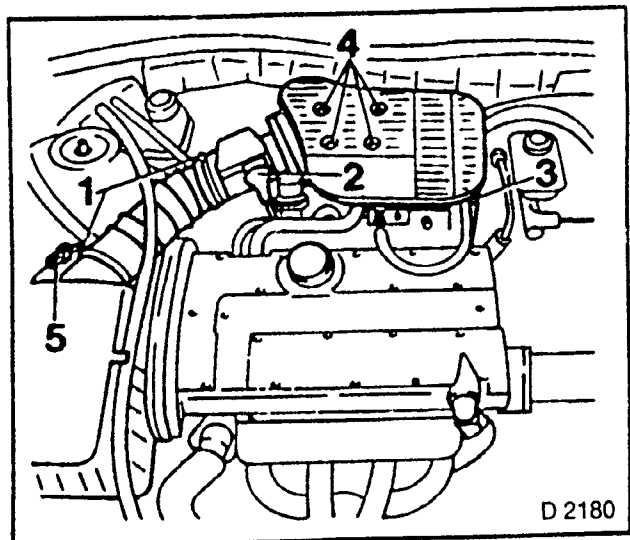


Fig. 530



## INSTALL, CONNECT

### C 20 LET:

1. Throttle valve manifold cover.
2. Air hose (1).

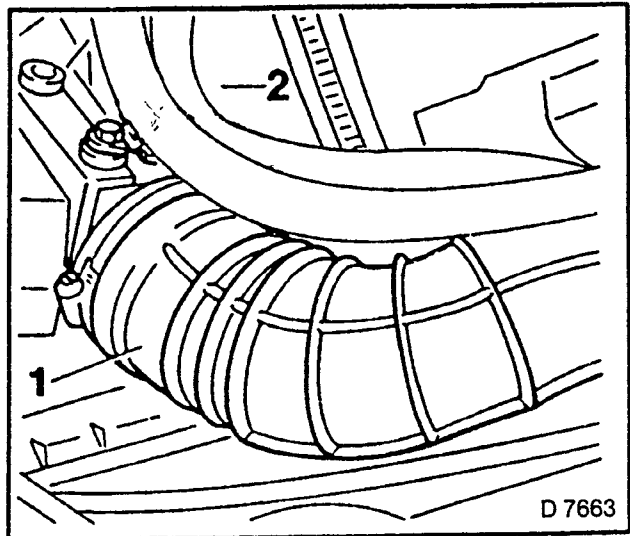


Fig. 531

## INSTALL, CONNECT

1. Lower hose bend to radiator.
2. Fan motor.
3. Fan motor multi-plug.
4. Ground cable to battery.

## INSPECT

1. Check engine oil level, correct if necessary.
2. Top up and bleed cooling system.
3. Charge and evacuate hydraulic system — See Section K

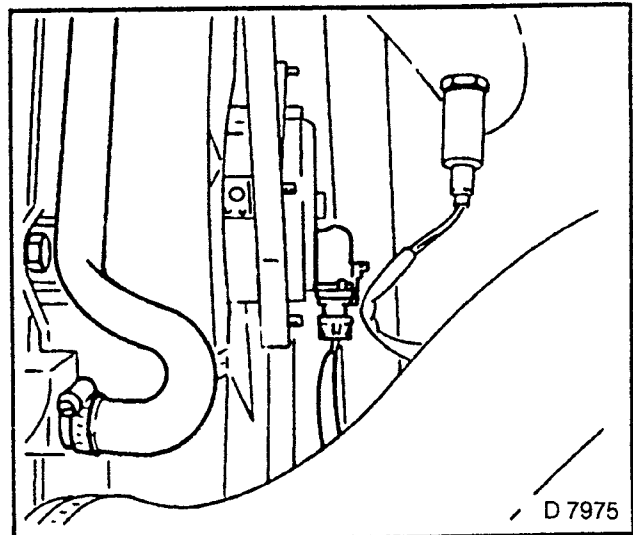


Fig. 532

## Engine — Repair using Short Block

### ATTACHING PARTS, REMOVE

1. Mount engine on Mounting Trestle KM-412.
2. Use Adapter KM-412-8
3. Drain engine oil — place collecting basin underneath.
4. Install oil drain plug — 45 Nm

### REMOVE, DISCONNECT

1. Front toothed belt cover.
2. Loosen tension roller (arrow) — toothed belt.
3. Tension roller, guide roller — note spacer sleeve.

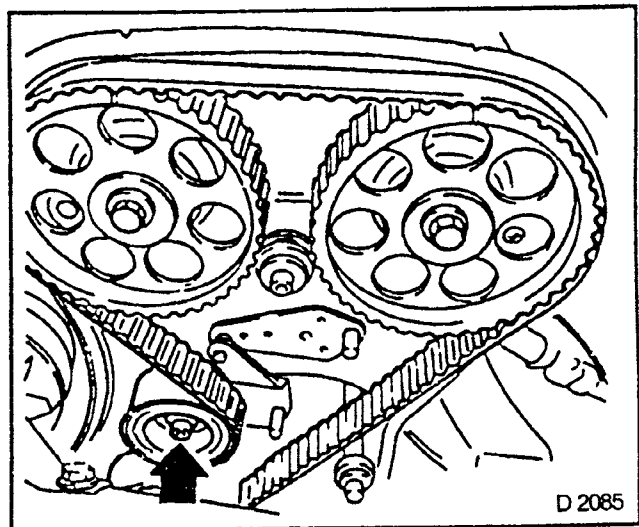


Fig. 533

**REMOVE, DISCONNECT**

1. Ignition cable cover.
2. Spark plug connection — KM-717.
3. Crankcase housing ventilation hose connection from cylinder head cover.
4. Cylinder head cover.
5. Camshaft sprockets — counterhold on hex of camshaft with wrench.

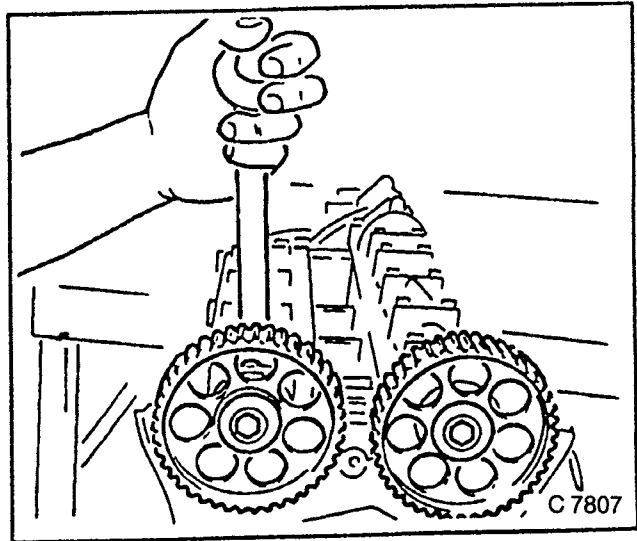


Fig. 534

**REMOVE, DISCONNECT**

1. Rear toothed belt cover.
2. On vehicles with front wheel drive: Intake manifold — cylinder block support.
3. Cylinder head bolts. In illustrated order with MKM-604-19 (Torx Nut E 14).

**NOTE:**  
**LOOSEN CYLINDER HEAD BOLTS FIRST 1/4, THEN 1/2 TURN.**  
**WHEN REMOVING CYLINDER HEAD BOLTS, NOTE STEEL WASHERS.**

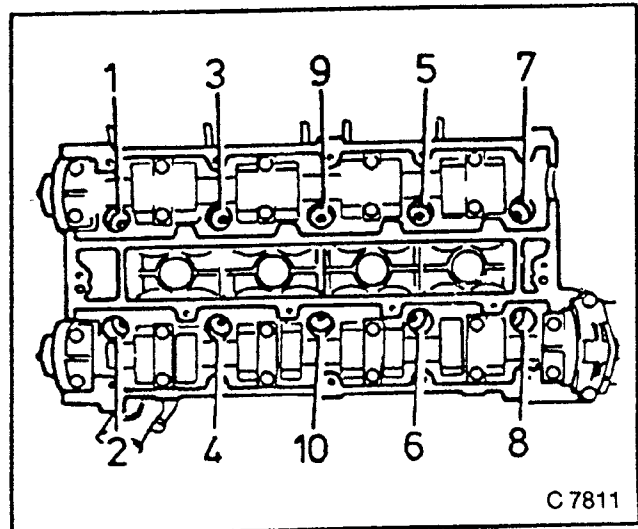


Fig. 535

**REMOVE, DISCONNECT**

1. Water pump.
2. Toothed belt drive gear — if necessary.
3. Install Remover KM-210-A with KM-516 and KM-647

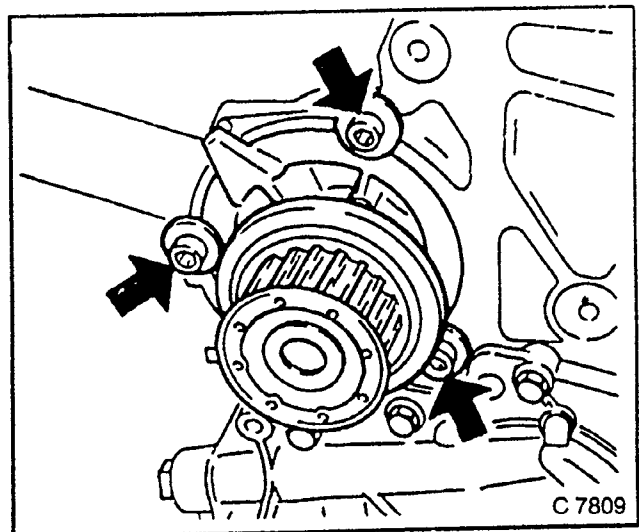
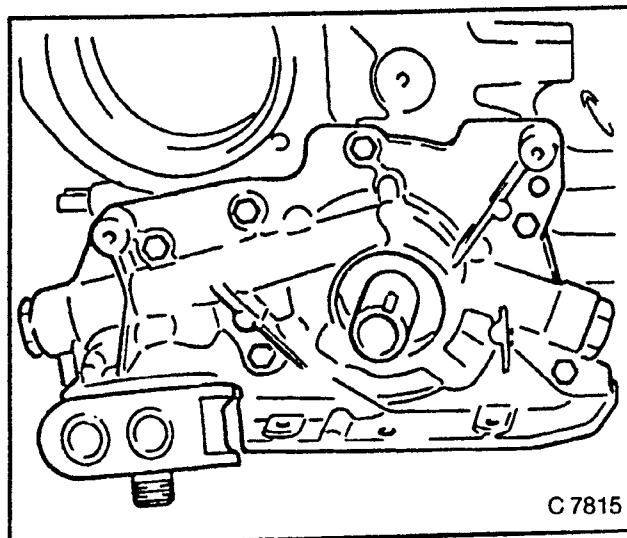


Fig. 536

**REMOVE, DISCONNECT**

1. Oil pan.
2. Oil intake pipe.
3. Oil intake pipe bracket.
4. Baffle plate.
5. Spacing ring from crankshaft journal.
6. Oil pump.

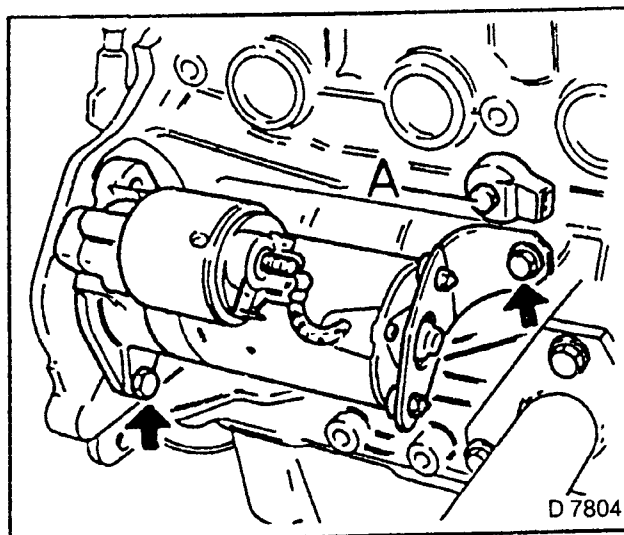


C 7815

Fig. 537

**REMOVE, DISCONNECT**

1. Coolant hose from water inlet connection.
2. Coolant pipe.
3. Oil temperature switch.
4. Starter with support (arrows).
5. Knock sensor (A).



D 7804

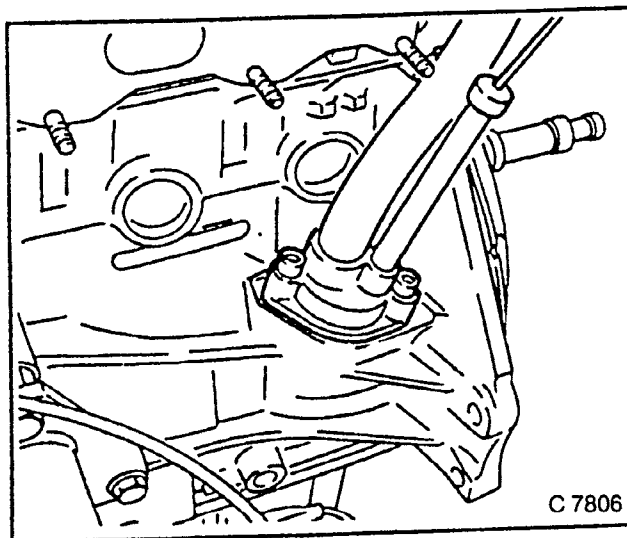
Fig. 538

**REMOVE, DISCONNECT**

1. Inductive pulse pick-up.
2. Engine vent flange.

**CLEAN****INSPECT**

All parts, replace if necessary.



C 7806

Fig. 539

## New Short Block — Complete

### INSTALL, CONNECT

1. Centering sleeve in cylinder head and clutch housing.

### TIGHTEN (TORQUE)

1. Engine vent flange to cylinder block — 25 Nm.
2. Inductive pulse pick-up to cylinder block — 6 Nm. (Use new seal ring).
3. Starter to cylinder block — 45 Nm.
4. Knock sensor to cylinder block — 20 Nm.
5. Starter support to cylinder block — 25 Nm.
6. Oil temperature switch to cylinder block — 30 Nm. (Use new gasket).
7. Coolant pipe to cylinder block — 20 Nm.

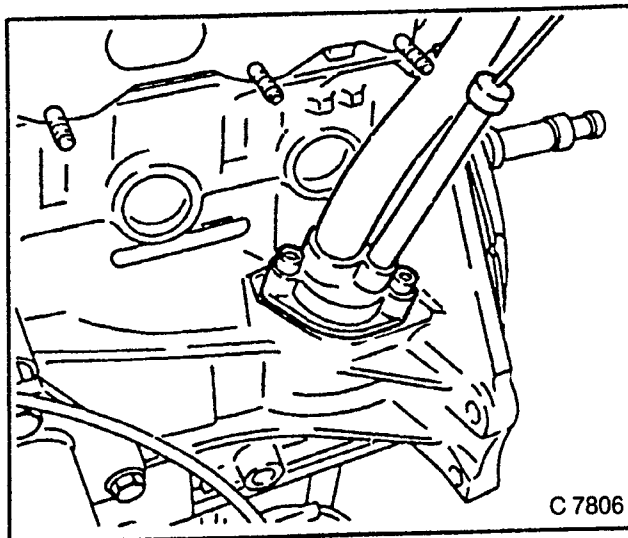


Fig. 540

### INSTALL, CONNECT

1. Coolant hose to water inlet connection.
2. Oil pump with new gasket — 6 Nm.
3. Seal ring — KM-693, use Torx bolt (1) with washer (2) of toothed belt drive pinion.
4. Coat seal lips with protective grease.

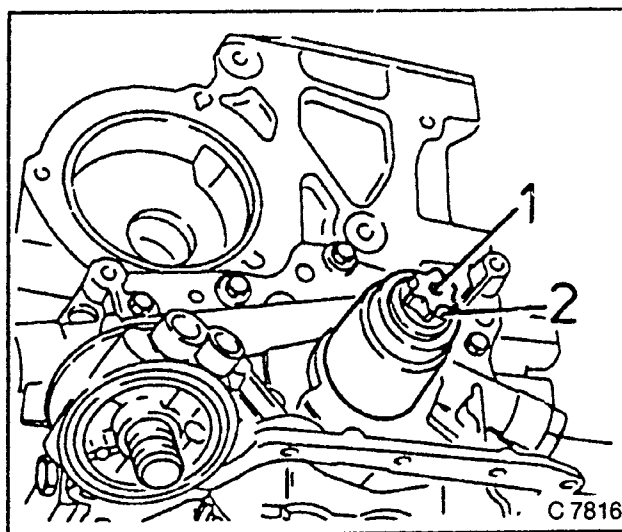


Fig. 541

### INSTALL, CONNECT

1. Coat fore part of spacing ring with Sealing Compound Locktite 515 flexible gasket or equivalent.
2. Toothed belt drive pinion — observe installation position.

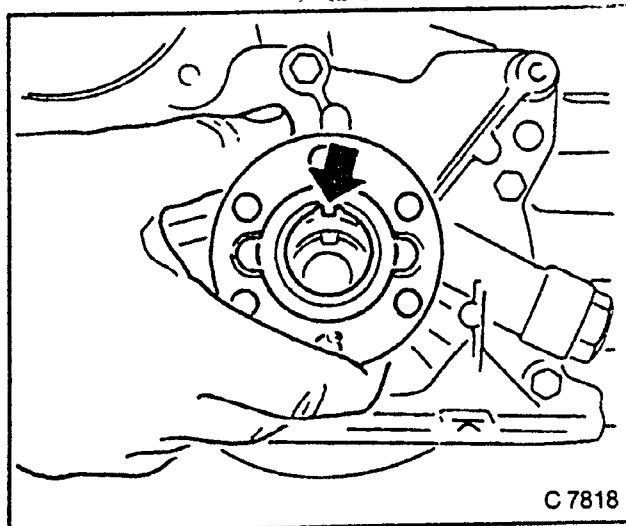


Fig. 542

3. Position piston of 1st cylinder to ignition TDC.
4. For this, attach MKM-604-21 (Torx Nut E 20) to fastening bolt of toothed belt drive pinion.
5. Coat joints of oil pump housing/cylinder block and bearing cover/cylinder block with Sealing Compound Locktite 242.

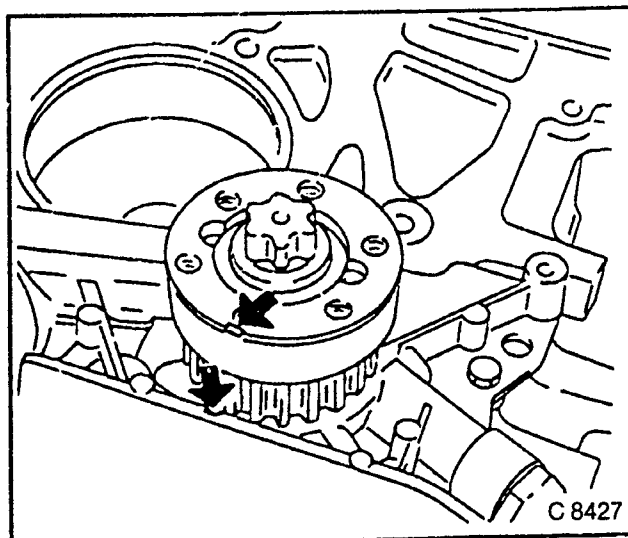


Fig. 543

### TIGHTEN (TORQUE)

1. Install cork seal and baffle plate.
2. Oil intake pipe bracket to cylinder block — 6 Nm.
3. Oil intake pipe (use new seal ring) to oil pump — 8 Nm.
4. Install second cork seal.
5. Oil pan to cylinder block — 15 Nm.\*  
\*Insert bolts with Locking Compound (Locktite 242).  
Maximum installation time ten minutes.
6. When installing cork seals, check that all spacing rings are present.

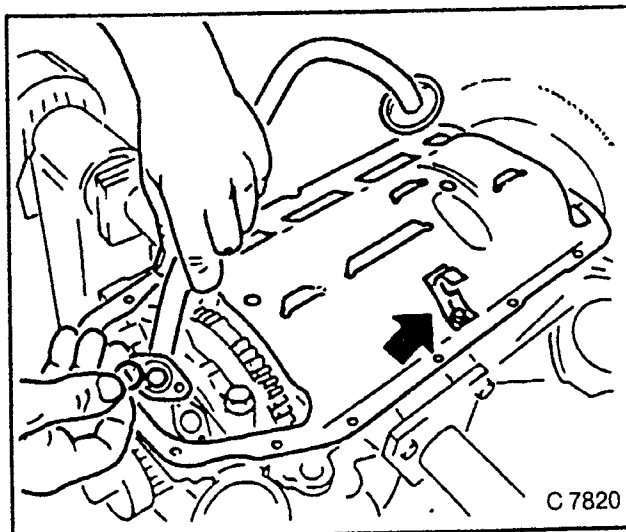


Fig. 544

### TIGHTEN (TORQUE)

1. Water pump to cylinder block — 25 Nm.
2. Coat cylinder block sealing surface and water pump seal ring lightly with Silicon Grease B04 00571.
3. Pull rear cover onto toothed belt gear.

### NOTE:

**SPRUES OF WATER PUMP AND CYLINDER BLOCK MUST ALIGN.**

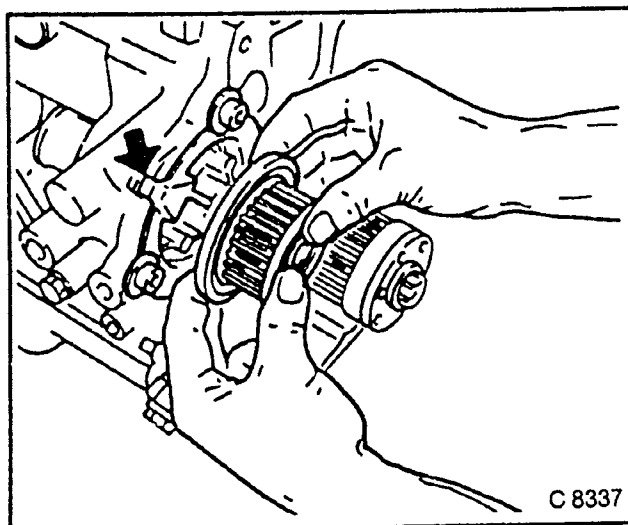


Fig. 545

## INSTALL, CONNECT

1. New cylinder head gasket — mark "OBEN/TOP" upwards and towards timing side of engine.
2. Place cylinder head on cylinder block.
3. Steel washers, tighten cylinder head bolts with MKM-604-19 (Torx Nut E 14) to stop.

### NOTE:

**USE NEW CYLINDER HEAD BOLTS.**

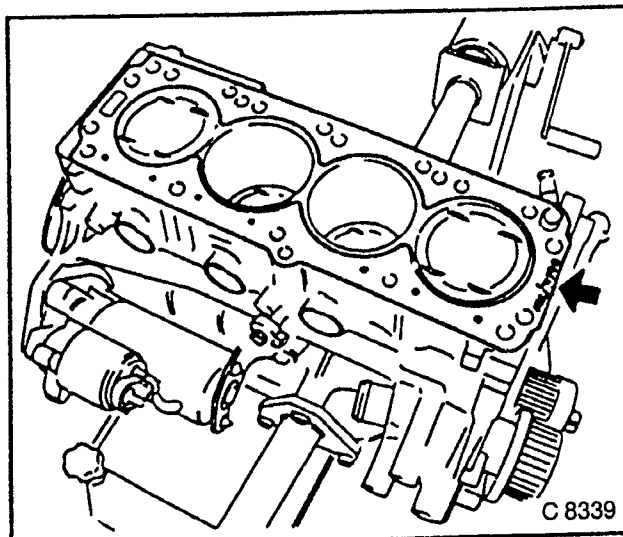


Fig. 546

## TORQUE — ANGLE METHOD

1. Cylinder head to cylinder block — 25 Nm. + 65° + 65° + 65°.
2. Tighten in illustrated order — Torque Wrench KM-470-B.
3. After test run, turn a further 30° + 15°.

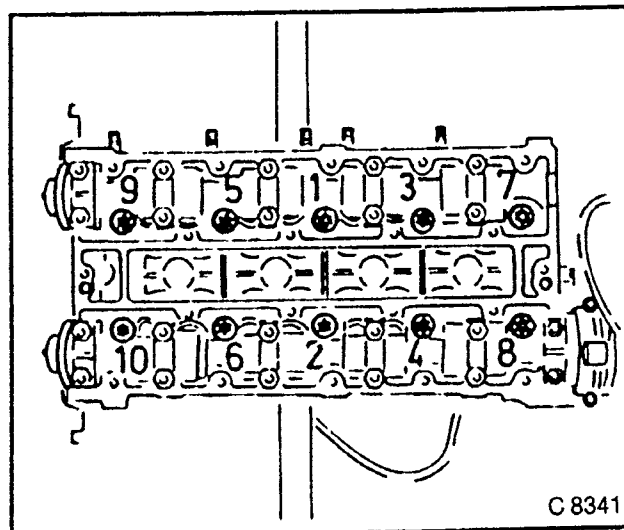


Fig. 547

## TIGHTEN (TORQUE)

1. Rear toothed belt cover to engine block — 6 Nm.
2. Intake pipe cylinder block support to intake pipe — 25 Nm.

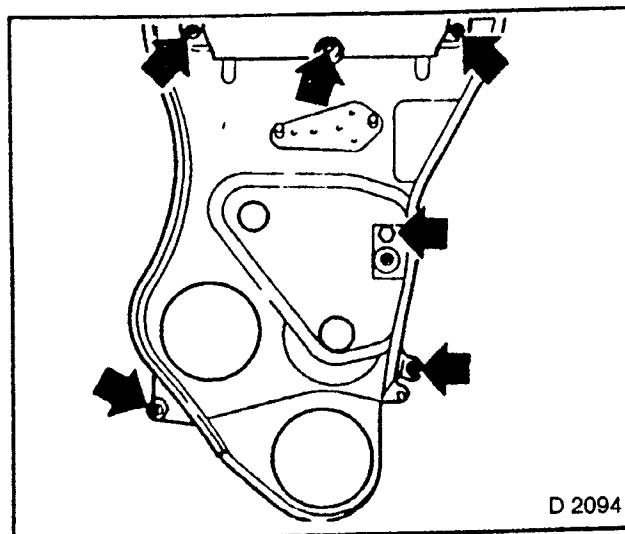


Fig. 548

**TIGHTEN (TORQUE)**

1. Guide roller (A) to cylinder block — 25 Nm.
2. Install tension roller (B) on cylinder block.

**NOTE**

**INSTALL SPACING SLEEVE WITH SMALLER DIAMETER TO GUIDE ROLLER OR TENSION ROLLER CARRIER PLATE.**

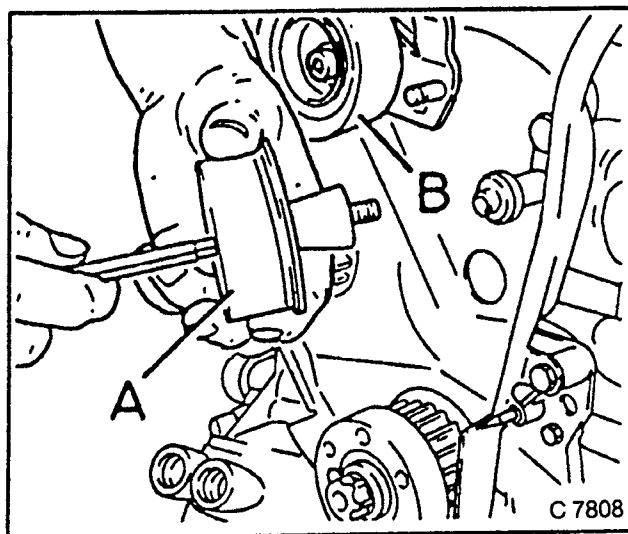


Fig. 549

**INSTALL, CONNECT**

1. Camshaft sprockets with timing markings towards front.
2. Turn pin (A) of camshaft to highest point, must engage in bore hole of camshaft sprocket when installed.

**TORQUE — ANGLE METHOD**

1. Camshaft sprocket to camshaft — 50 Nm + 60° + 15°. Use new bolt.
2. Counterhold with open-ended wrench on camshaft when installing.

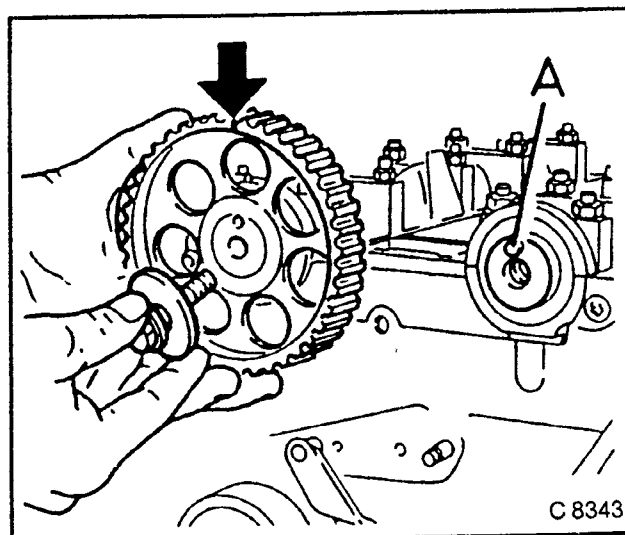


Fig. 550

**INSTALL, CONNECT**

1. Cylinder head cover with new gasket.
2. Crankcase vent hose connection to cylinder head cover.
3. Spark plug connection.
4. Ignition cable cover.

**TIGHTEN (TORQUE)**

1. Cylinder head cover to cylinder head — 8 Nm.
2. Ignition cable cover to cylinder head cover — 8 Nm.

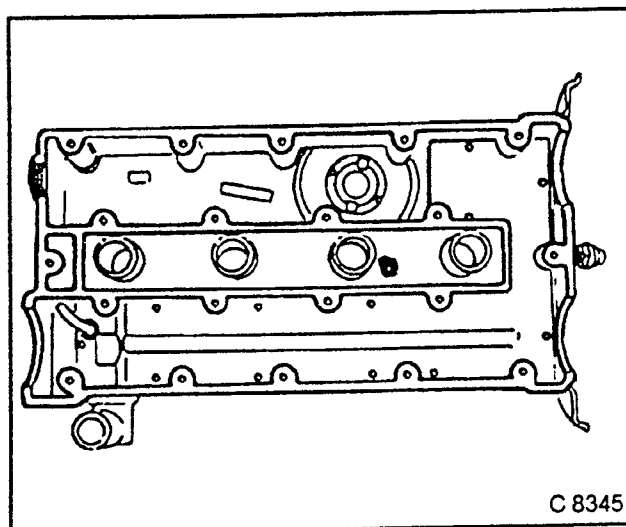


Fig. 551

**INSTALL NEW TOOTHED BELT.****ADJUST**

1. Toothed belt tension.  
See operation "Toothed Belt, Replace", page 184.
2. Top up engine oil to mark "MAX" on oil dipstick.

**REMOVE, DISCONNECT**

1. Engine from Mounting Trestle KM-412.
2. Adapter from engine.

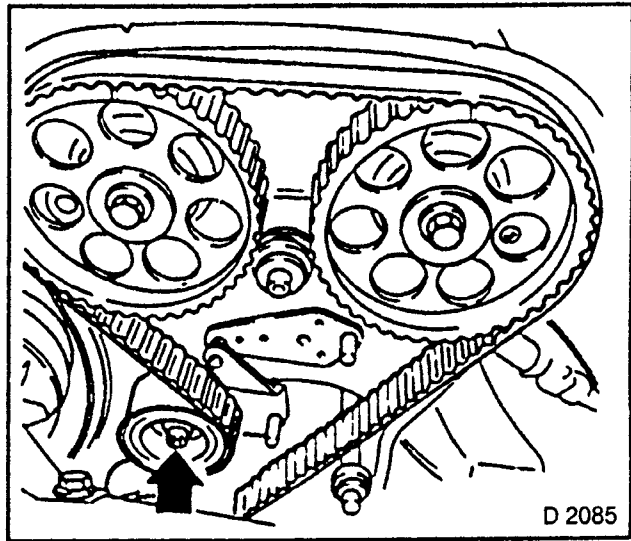
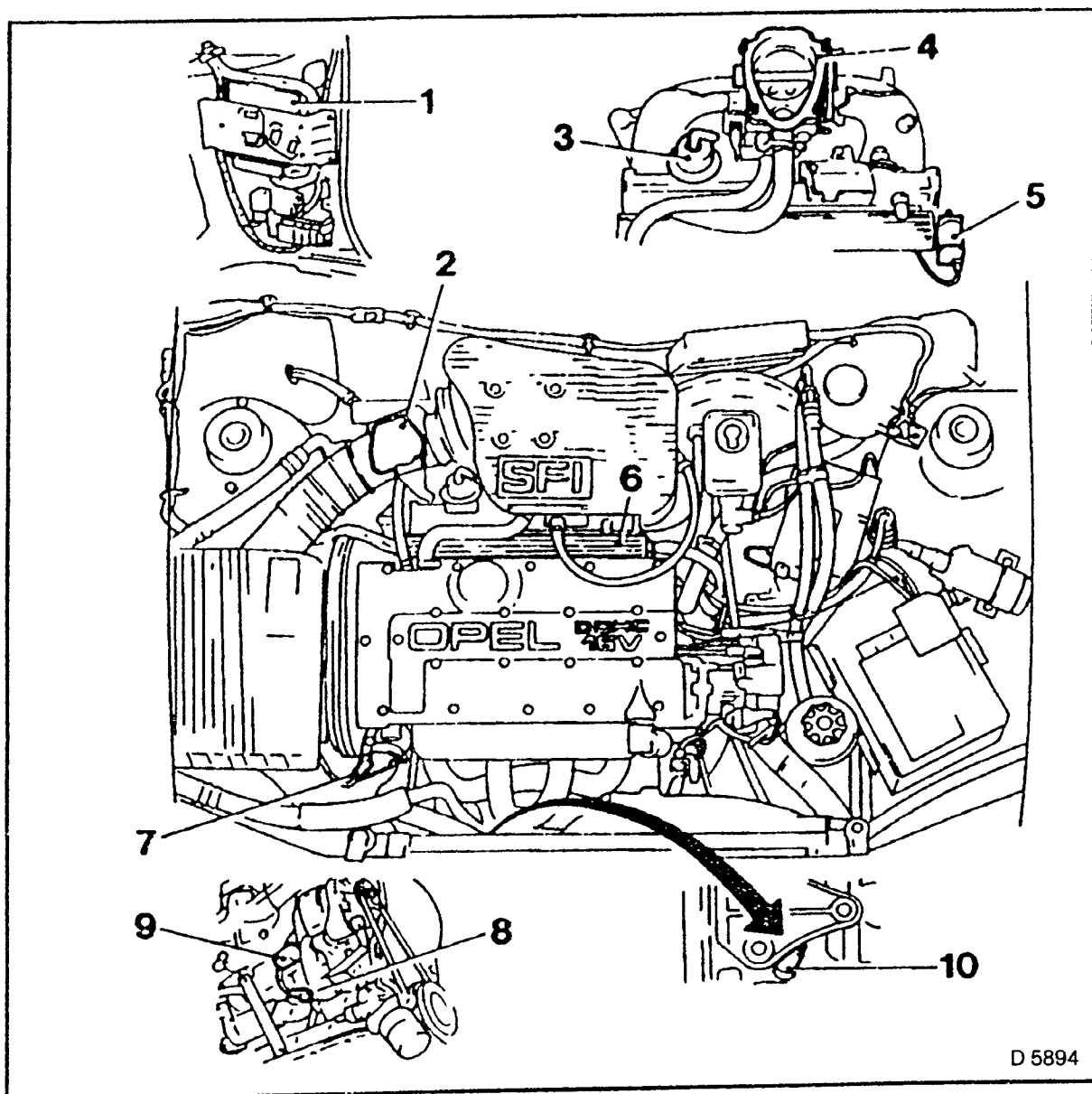


Fig. 552

**NOTE:**

1. Remove fastening bolt of toothed belt drive gear.
2. Install new fastening bolt after installation of engine.





D 5894

Fig. 553

## Motronic M 1.5.4 (C 20 XE)

- 1 Control unit  
(installation position in right footwell)
- 2 Hot wire mass air flow meter.
- 3 Fuel pressure regulator.
- 4 Throttle body.
- 5 Tank vent valve.
- 6 Injection valves plug strip.
- 7 Coolant temperature sensor.
- 8 Knock sensor.
- 9 Idle speed adjuster.
- 10 Inductive pulse pick-up.

## Throttle Body — Remove and Install

### REMOVE, DISCONNECT

1. Pre-volume chamber.
2. Fuel line bracket (1).
3. Throttle valve switch wiring harness plug (2).
4. Accelerator cable.
5. Crankcase vent hose (3).
6. Vacuum hose from fuel pressure regulator.

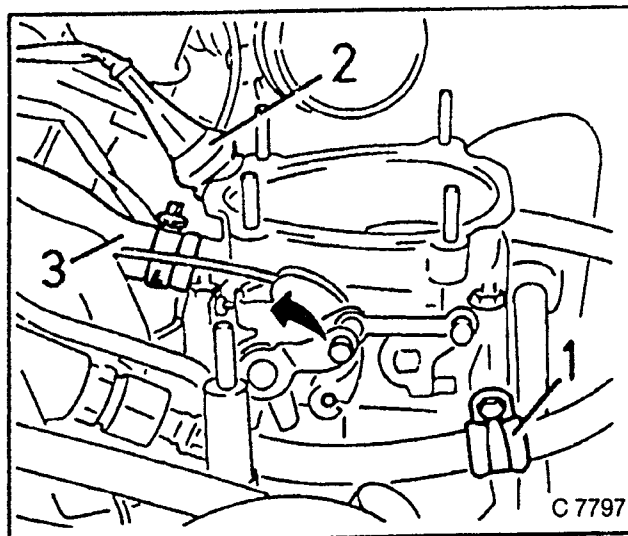


Fig. 554

### REMOVE, DISCONNECT

1. Throttle body.
2. Throttle valve switch.

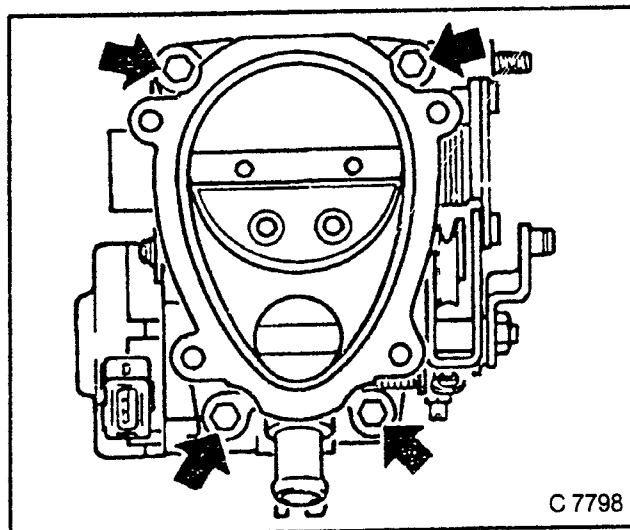


Fig. 555

### INSTALL, CONNECT

1. Throttle valve switch.
2. Throttle body — tightening torque 9 Nm.
3. Fuel pressure regulator vacuum hose.
4. Crankcase vent hose (3).
5. Accelerator cable.
6. Throttle valve switch wiring harness plug (2).
7. Fuel line bracket (1).
8. Pre-volume chamber.

### WARNING:

**IF THERE IS A DEFECT ON THE THROTTLE VALVE LINKAGE THE COMPLETE THROTTLE BODY TOGETHER WITH LINKAGE MUST BE REPLACED. A CORRECT ADJUSTMENT WITH WORKSHOP TOOLS IS NOT POSSIBLE.**

### ADJUST

Throttle valve switch.

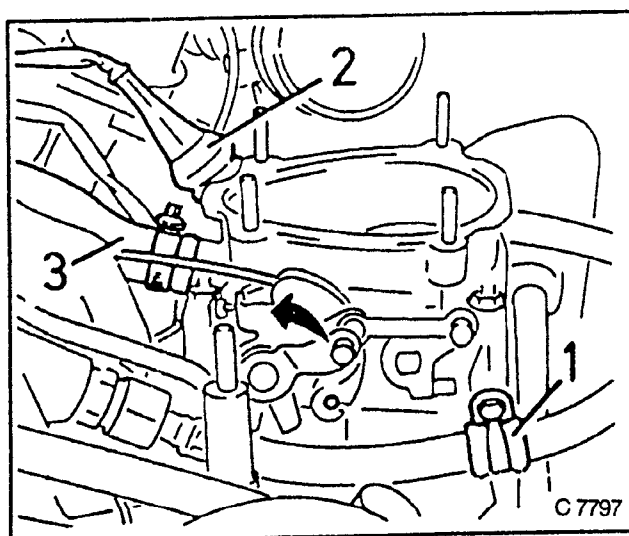


Fig. 556

## Throttle Valve Switch — Remove and Install

### REMOVE, DISCONNECT

1. Pre-volume chamber.
2. Hot wire mass air flow meter.
3. If necessary, throttle body.
4. Wiring harness plug (1).
5. Throttle valve switch (2).

### INSTALL, CONNECT

1. Adjust throttle valve switch.
2. Wiring harness plug.
3. Throttle body.
4. Hot wire mass air flow meter.
5. Pre-volume chamber.

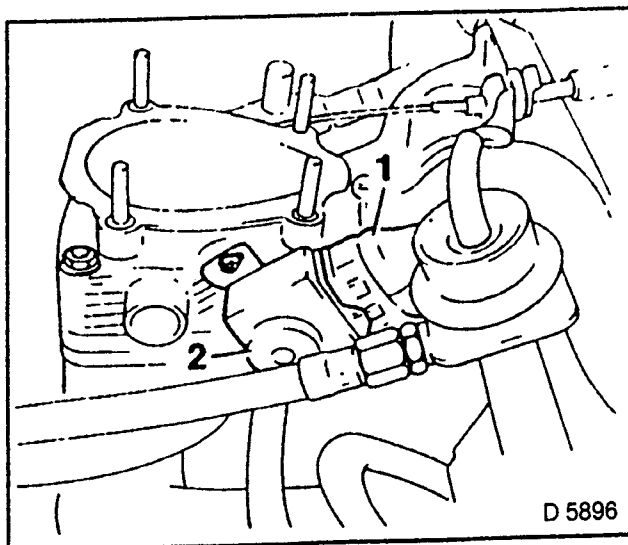


Fig. 557

## Throttle Valve Switch — Adjust

### REMOVE, DISCONNECT

1. Pre-volume chamber.
2. Hot wire mass air flow meter.
3. If necessary throttle body.

### ADJUST

1. Loosen bolts.
2. Turn switch anti-clockwise until resistance is noticeable.
3. Tighten throttle valve switch in this position. If the throttle valve is opened wide, there must be a noticeable click, which is repeated when closing.

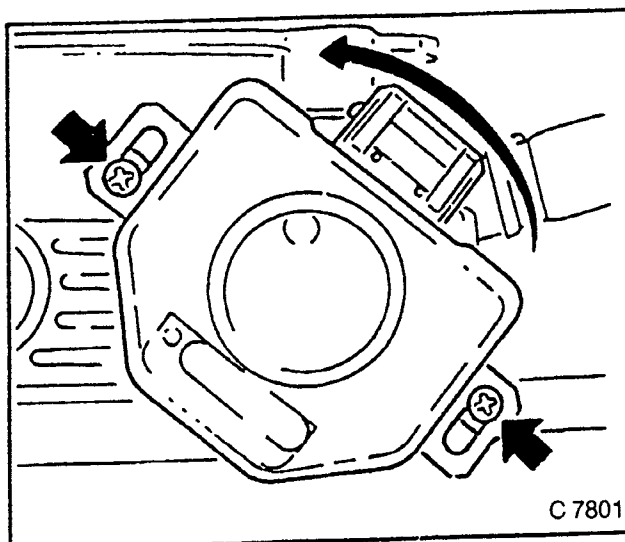


Fig. 558

### INSTALL, CONNECT

1. Throttle body.
2. Hot wire mass air flow meter.
3. Pre-volume chamber.

## Injection Valves — Remove and Install

### REMOVE, DISCONNECT

1. Pre-volume chamber.
2. Bowden cable (1).

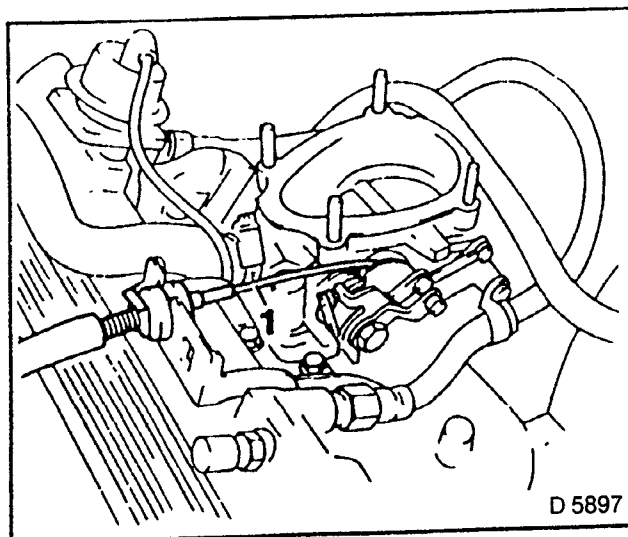


Fig. 559

**REMOVE, DISCONNECT**

1. Crankcase vent hoses (1), (2).
2. Fuel pressure regulator vacuum hose (3).
3. Wiring harness plug — hot wire mass air flow meter (4).
4. Throttle valve switch wiring harness plug (5).

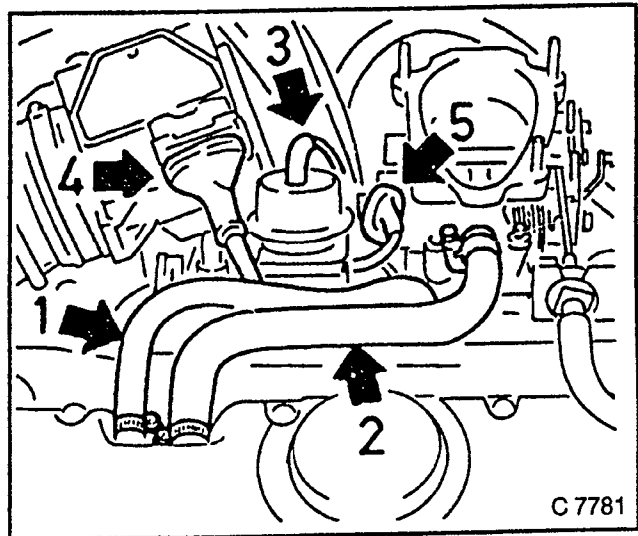


Fig. 560

**REMOVE, DISCONNECT**

1. Bowden cable bracket.

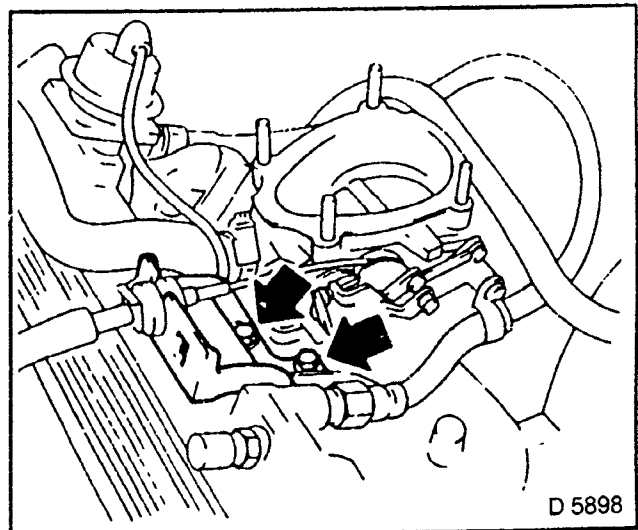


Fig 561

**REMOVE, DISCONNECT**

1. Injection valves plug strip.
2. Retaining clamp from 1st cylinder injection valve from plug strip.
3. Remove plug strip.
4. Insert retaining clamp in plug strip.

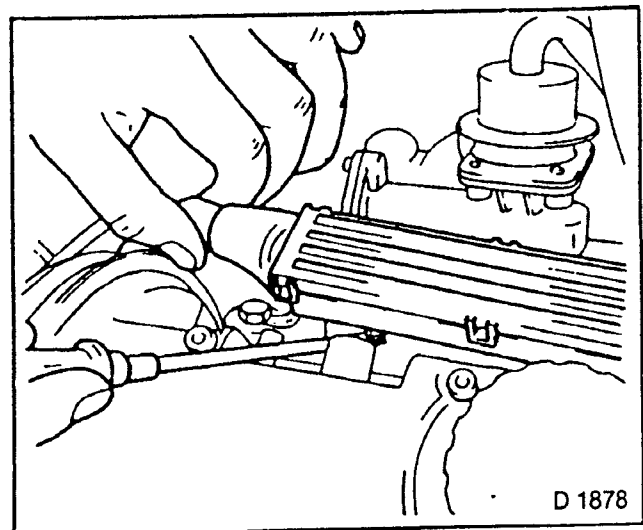


Fig 562

**REMOVE, DISCONNECT**

1. Ground cables (1) and (2).
2. Fuel distributor pipe with injection valves.

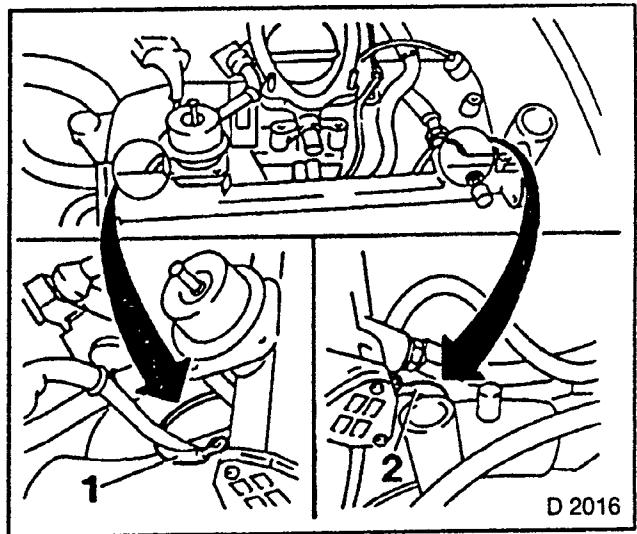


Fig. 563

**REMOVE, DISCONNECT**

1. Spring clip.
2. Injection valve from fuel distributor pipe.

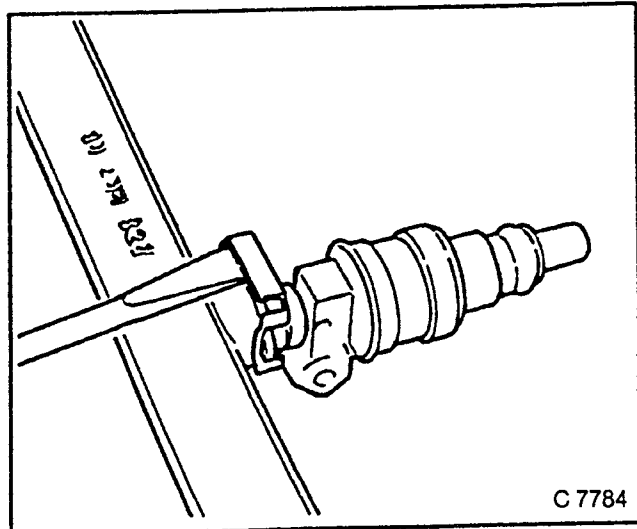


Fig. 564

**NOTE:**

**USE NEW SEAL RINGS  
NOTE CORRECT POSITION OF  
HOSES AND CABLES.**

**INSTALL, CONNECT**

1. Injection valve to fuel distribution pipe — spring clip.
2. Fuel distributor pipe with injection valves — nuts — ground cable — nuts.
3. Injection valves plug strip.
4. Accelerator cable bracket — tightening torque 8 Nm.

**INSTALL, CONNECT**

1. Throttle valve switch wiring harness plug.
2. Hot wire mass air flow meter wiring harness plug.
3. Fuel pressure regulator vacuum hose.
4. Crankcase vent hoses.
5. Pre-volume chamber.

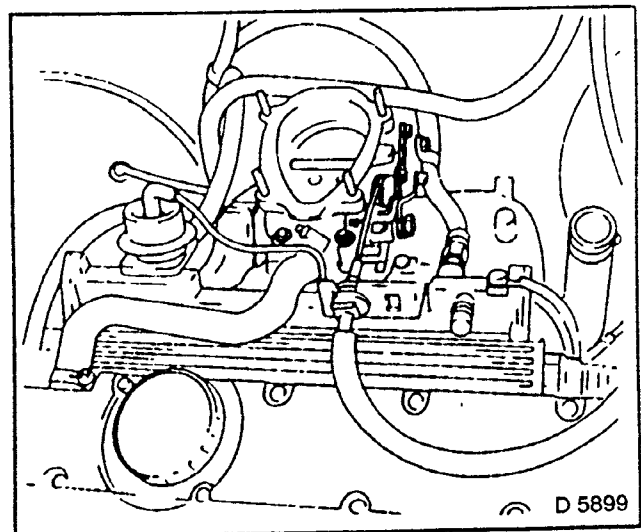


Fig. 565

**ADJUST**

Bowden cable.

## Hot Wire Mass Air Flow Meter — Remove and Install

### REMOVE, DISCONNECT

1. Wiring harness plug.
2. Hose clamps (1).
3. Hot wire mass air flow meter.

### INSTALL, CONNECT

1. Hot wire mass air flow meter.
2. Hose clamps.
3. Wiring harness plug.

### NOTE:

**ENSURE THAT HOSES AND HOSE CLAMPS ARE IN GOOD CONDITION AND CORRECTLY SEATED.**

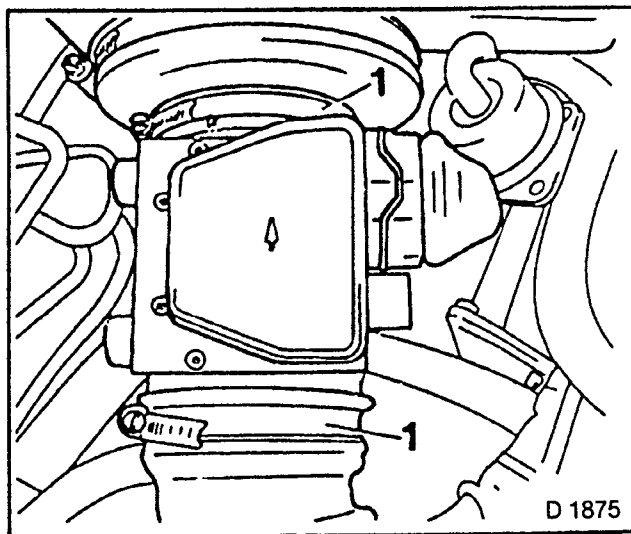


Fig. 566

## High Voltage Distributor — Remove and Install (2.0 ltr. with Motronic ML 4.1. M 1.5)

### REMOVE, DISCONNECT

High voltage distributor cap — MKM-604-B.

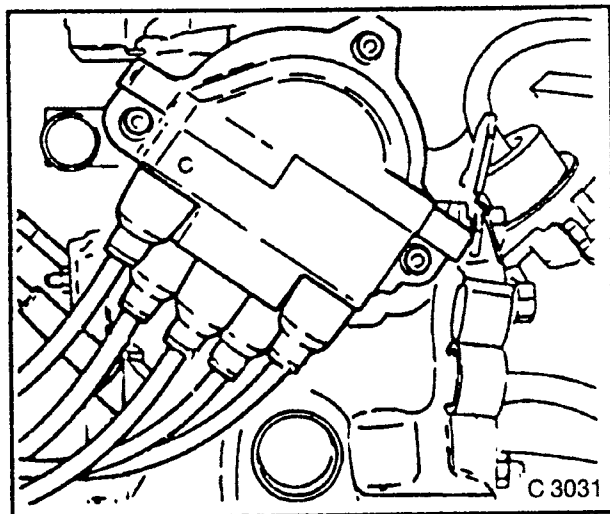


Fig. 567

### REMOVE, DISCONNECT

1. Condensation barrier.
2. High voltage distributor armature.

### INSTALL, CONNECT

1. High voltage distributor armature.
2. Condensation barrier.
3. High voltage distributor cap.
4. Insert bolts with Locking Compound (Loctite 242).

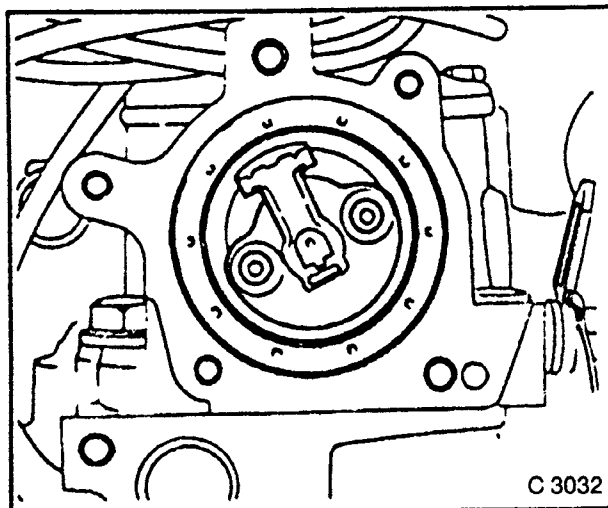


Fig. 568

## Inductive Pulse Pick-up — Remove and Install

### REMOVE, DISCONNECT

1. Disconnect wiring harness plug for inductive pulse pick-up — note cable routing.

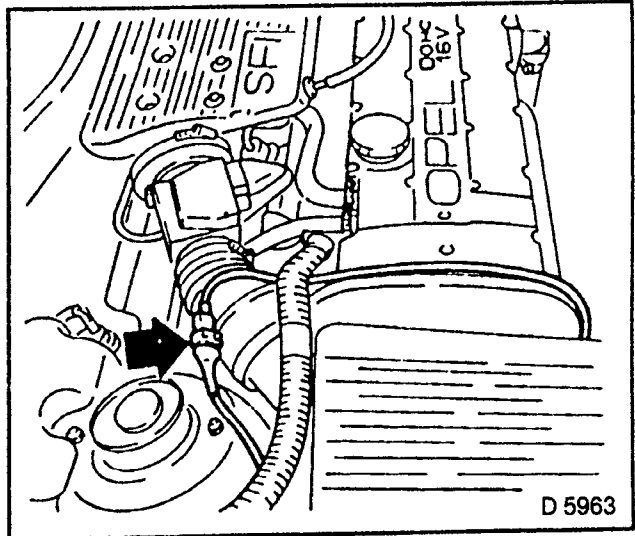


Fig. 569

### REMOVE, DISCONNECT

1. Inductive pulse pick-up.
2. Seal ring.

### INSTALL, CONNECT

1. Inductive pulse pick-up with new seal ring — torque 6 Nm.
2. Connect wiring harness plug for inductive pulse pick-up.
3. Note correct wiring installation.

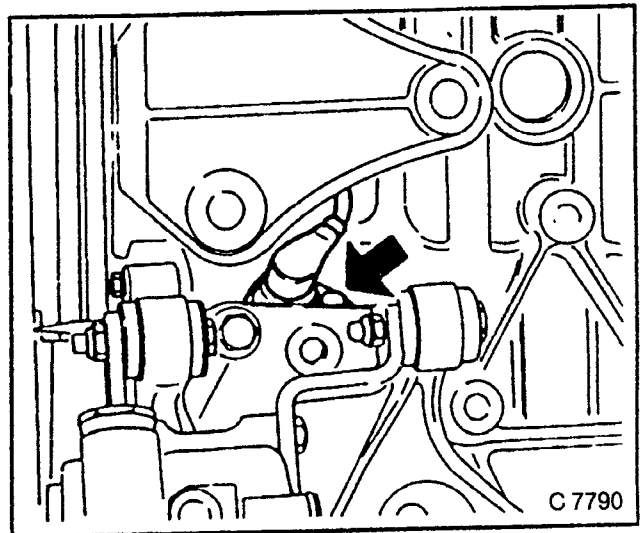


Fig. 570

## Knock Sensor — Remove and Install

### REMOVE, DISCONNECT

1. Ground cable from battery.
2. Wiring harness plug for knock sensor.
3. Knock sensor.

### CLEAN

Contact surfaces on knock sensor — engine block.

### TIGHTEN (TORQUE)

1. Knock sensor to engine block — 20 Nm. Observe extreme cleanliness.
2. Wiring harness plug for knock sensor.
3. Ground cable to battery.

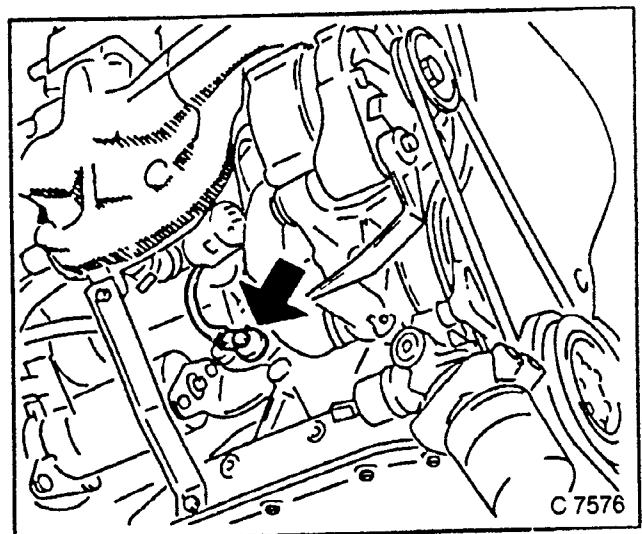


Fig. 571

## Ignition Coding Plug

### WARNING

Do not change ignition coding plug.

The coding plug adapts the ignition characteristic curve to the regulations of the various countries (noise, exhaust gas).

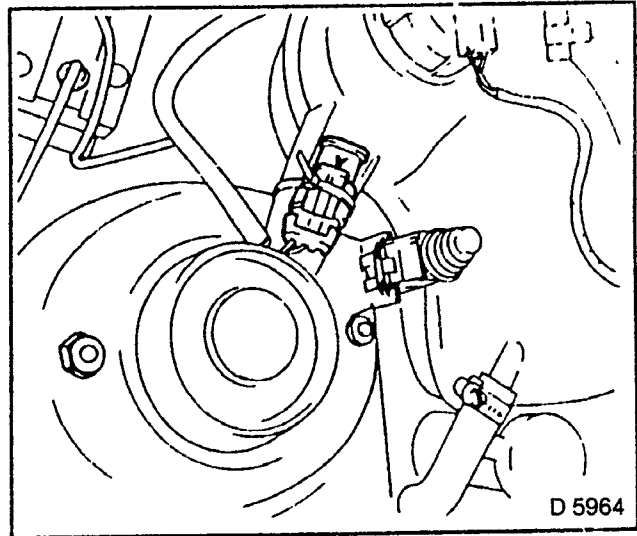


Fig. 572

## Fuel Pressure Regulator — Remove and Install

### CAUTION:

**FUEL ESCAPES  
OBSERVE SAFETY MEASURES AND  
NATIONAL REGULATIONS.**

### REMOVE, DISCONNECT

1. Pre-volume chamber.
2. Hot wire mass air flow meter wiring harness plug.
3. Throttle valve switch.
4. Wiring harness plug.
5. Fuel pressure regulator vacuum hose.
6. Fuel pressure regulator

### INSTALL, CONNECT

1. Fuel pressure regulator with new seal rings — tightening torque 4 Nm.
2. Fuel pressure regulator vacuum hose.
3. Throttle valve switch wiring harness plug.
4. Hot wire mass air flow meter wiring harness plug.
5. Pre-volume chamber.

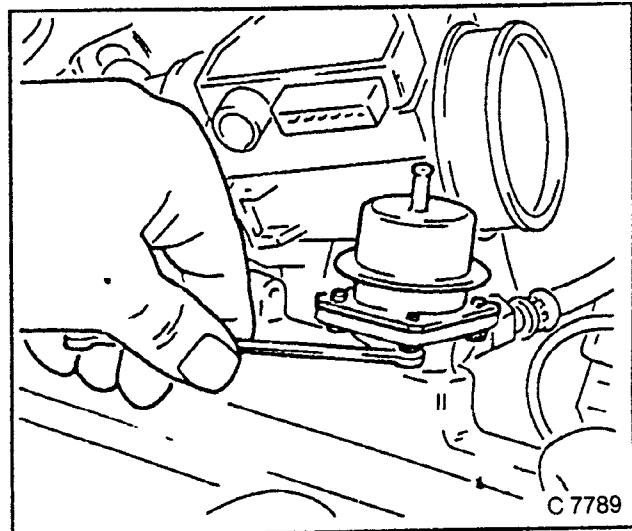


Fig. 573



## Fuel Pressure — Check

### REMOVE, DISCONNECT

1. Open closure bolt (1) slowly — pressure reduction.
2. Fuel pressure regulator vacuum hose connected to intake manifold.

### INSPECT

1. Fuel pressure gauge KM-J-34740-91 to checking connection.
2. Bleed fuel pressure gauge.
3. Start engine — idle speed.
4. Fuel pressure — prescribed value: 3 bar/43,5 psi.

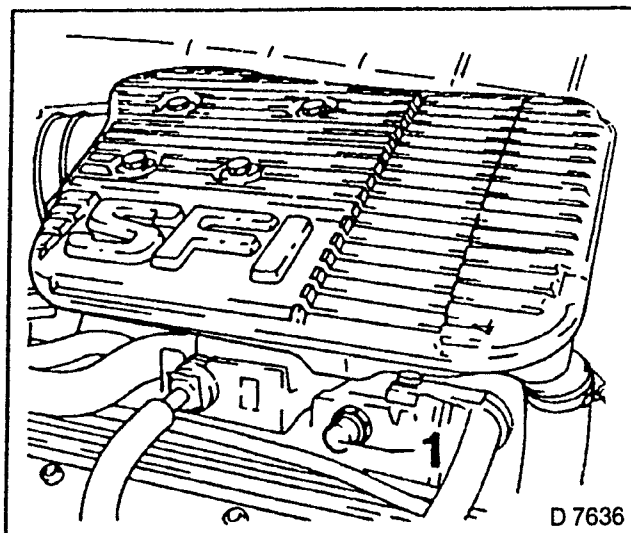


Fig. 574

## Idle Speed Adjuster — Remove and Install

### NOTE:

**MARK INSTALLATION POSITION OF HOSES.**

### REMOVE, DISCONNECT

1. Ground cable from battery.
2. Hose (1) from pre-volume chamber.

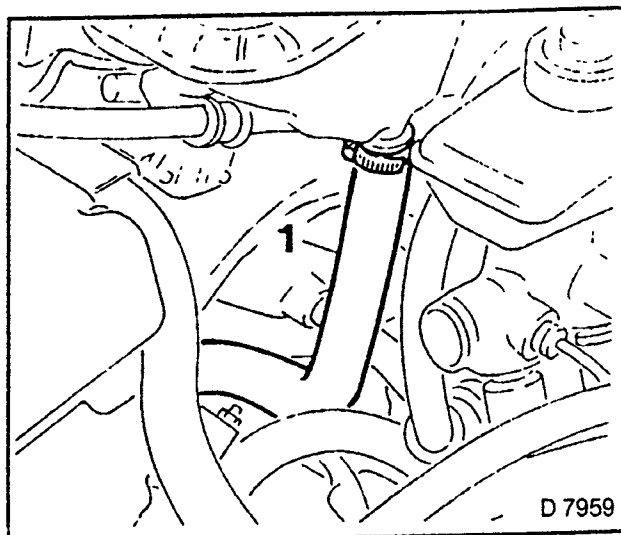


Fig. 575

### REMOVE, DISCONNECT

1. Engine compartment cover.
2. Idle speed adjuster wiring harness plug.
3. Idle speed adjuster with hoses.
4. Hoses from idle speed adjuster.

### INSTALL, CONNECT

1. Hoses to idle speed adjuster.
2. Idle speed adjuster with hoses.
3. Hose (Fig. 575-1) to pre-volume chamber.
4. Idle speed adjuster wiring harness plug.
5. Ground cable to battery.
6. Ensure that hoses and hose clamps are in good condition and correctly seated.

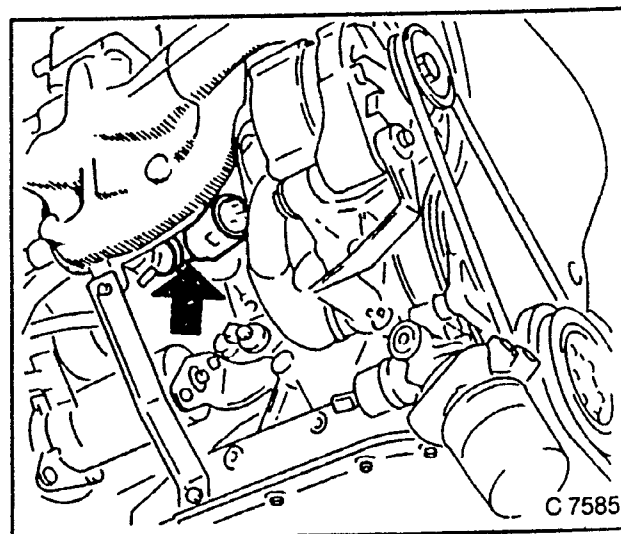


Fig. 576

## Control Unit — Remove and Install

### REMOVE, DISCONNECT

1. Switch off ignition.
2. Storage compartment.
3. Front right footwell panelling.
4. Control unit.
5. Wiring plug.

### INSTALL, CONNECT

1. Wiring plug.
2. Control unit.
3. Front right footwell panelling.
4. Storage compartment.

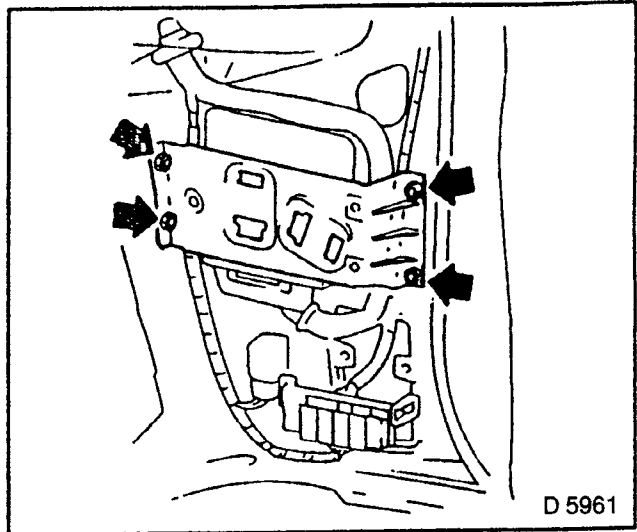


Fig. 577

## Coolant Temperature Sensor — Remove and Install

### CAUTION

**COOLANT ESCAPES  
PLACE COLLECTING BASIN  
UNDERNEATH.**

### REMOVE, DISCONNECT

1. Wiring harness plug for coolant temperature sensor.
2. Coolant temperature sensor with seal ring.

### TIGHTEN (TORQUE)

1. Coolant temperature sensor to thermostat housing — 11 Nm.
2. Use new seal ring.
3. Wiring harness plug for coolant temperature sensor.

### NOTE:

**FILL UP AND BLEED COOLING  
SYSTEM.**

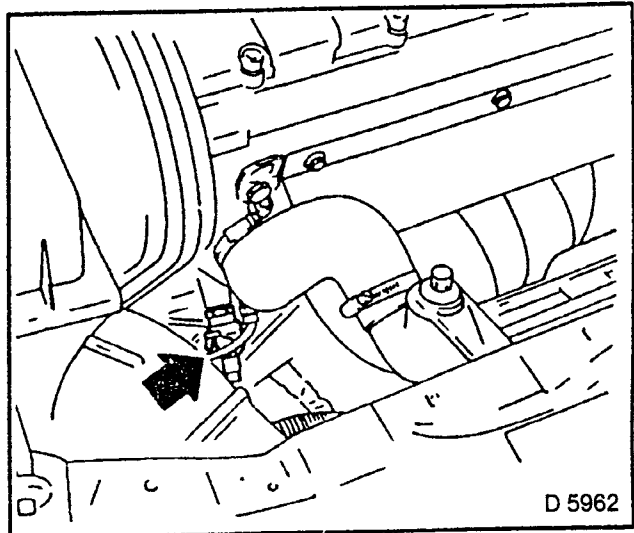


Fig. 578

## Pre-volume Chamber — Remove and Install

### REMOVE, DISCONNECT

1. Hose (1).
2. Hose clip (2).
3. Bolts (3).
4. Pre-volume chamber — note seal ring.

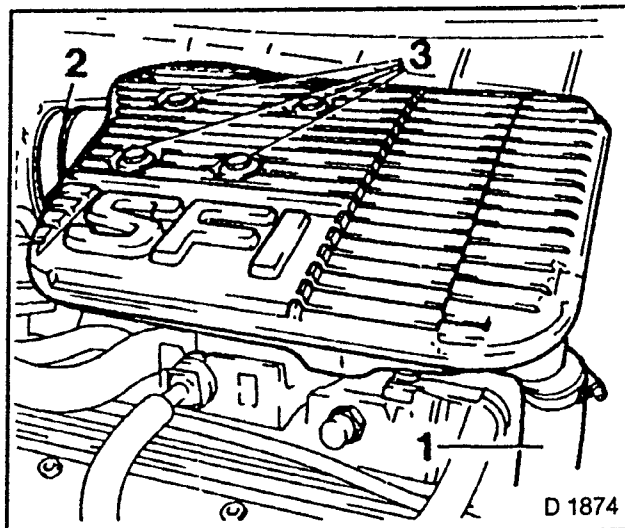


Fig. 579

### NOTE:

1. Before inserting the seal ring, coat four to six fixing points in the gasket guide of the pre-volume chamber with Cement, Catalogue No. 15 04 851 (09 293 725).
2. Note correct seating of seal ring.
3. Repeat fixing each time the pre-volume chamber is removed.

### INSTALL, CONNECT

1. Pre-volume chamber.
2. Hose clip Fig. 579-2.
3. Bolts Fig. 579-3.
4. Hose Fig. 579-1.

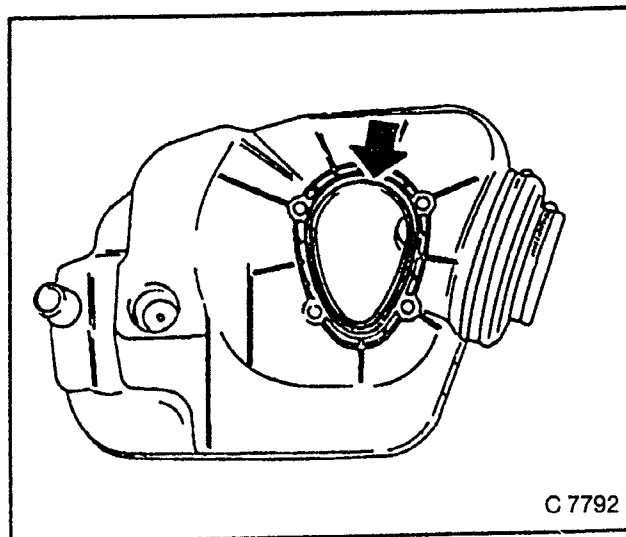


Fig. 580

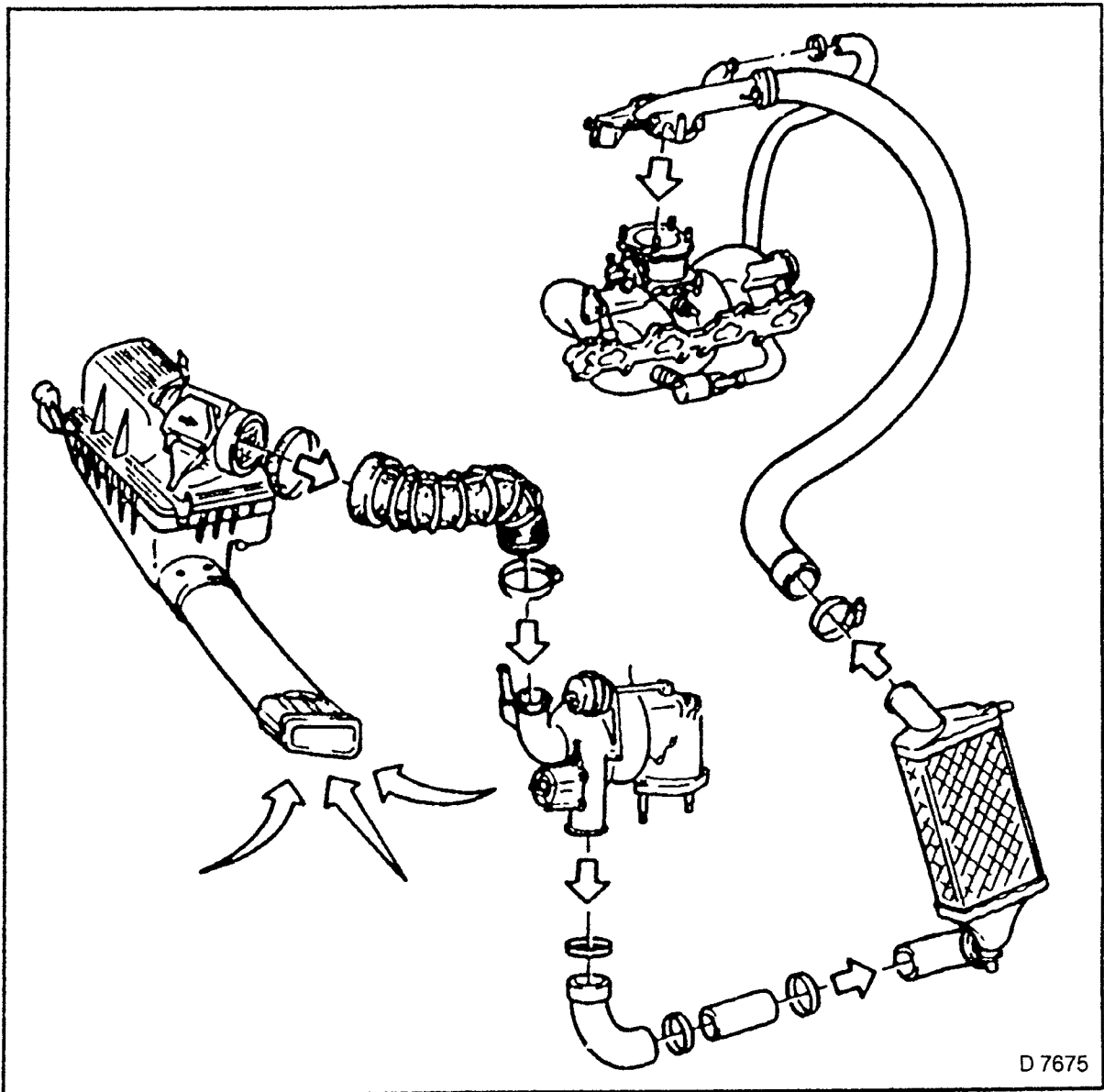
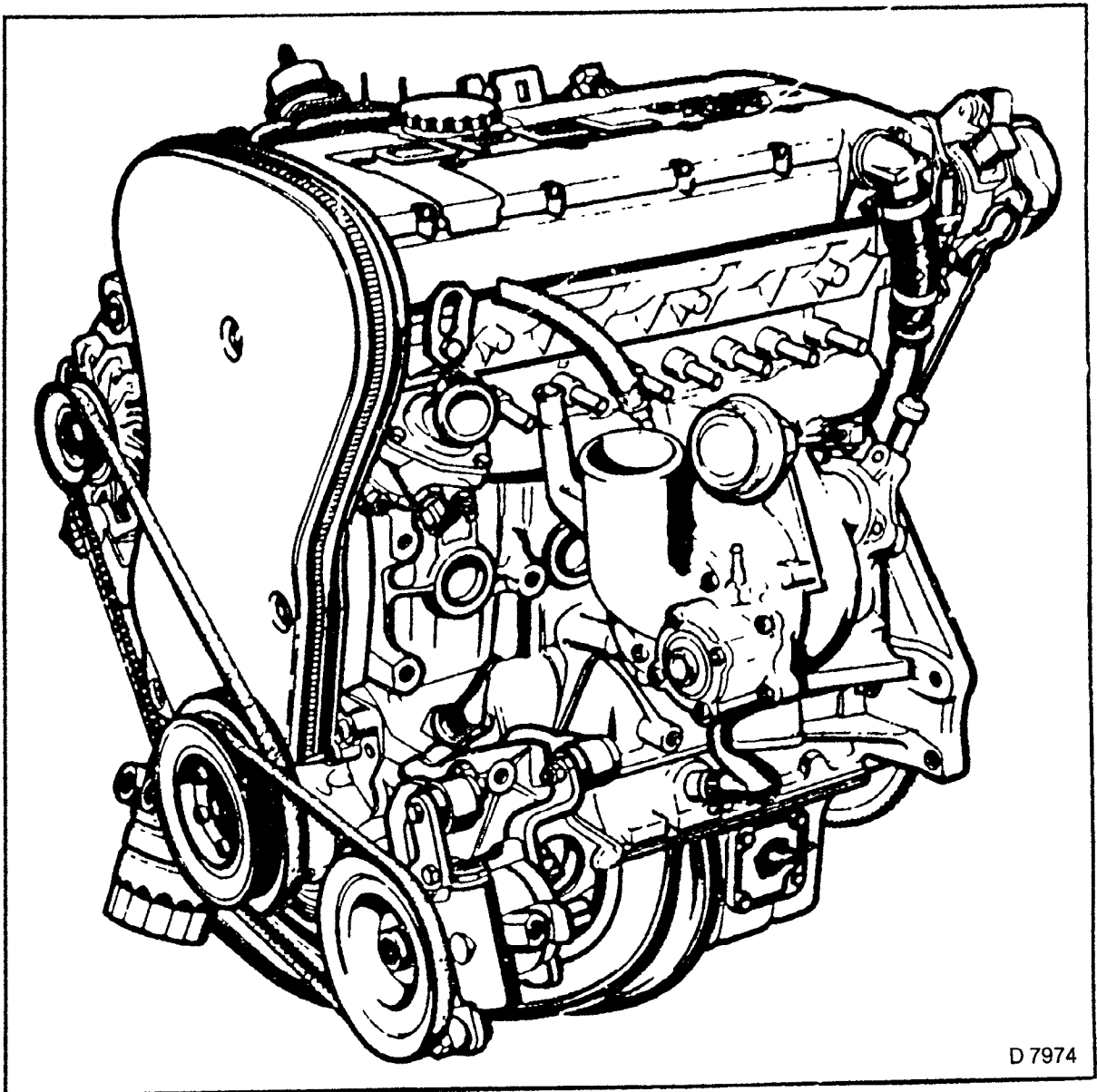


Fig. 581 — Air Feed

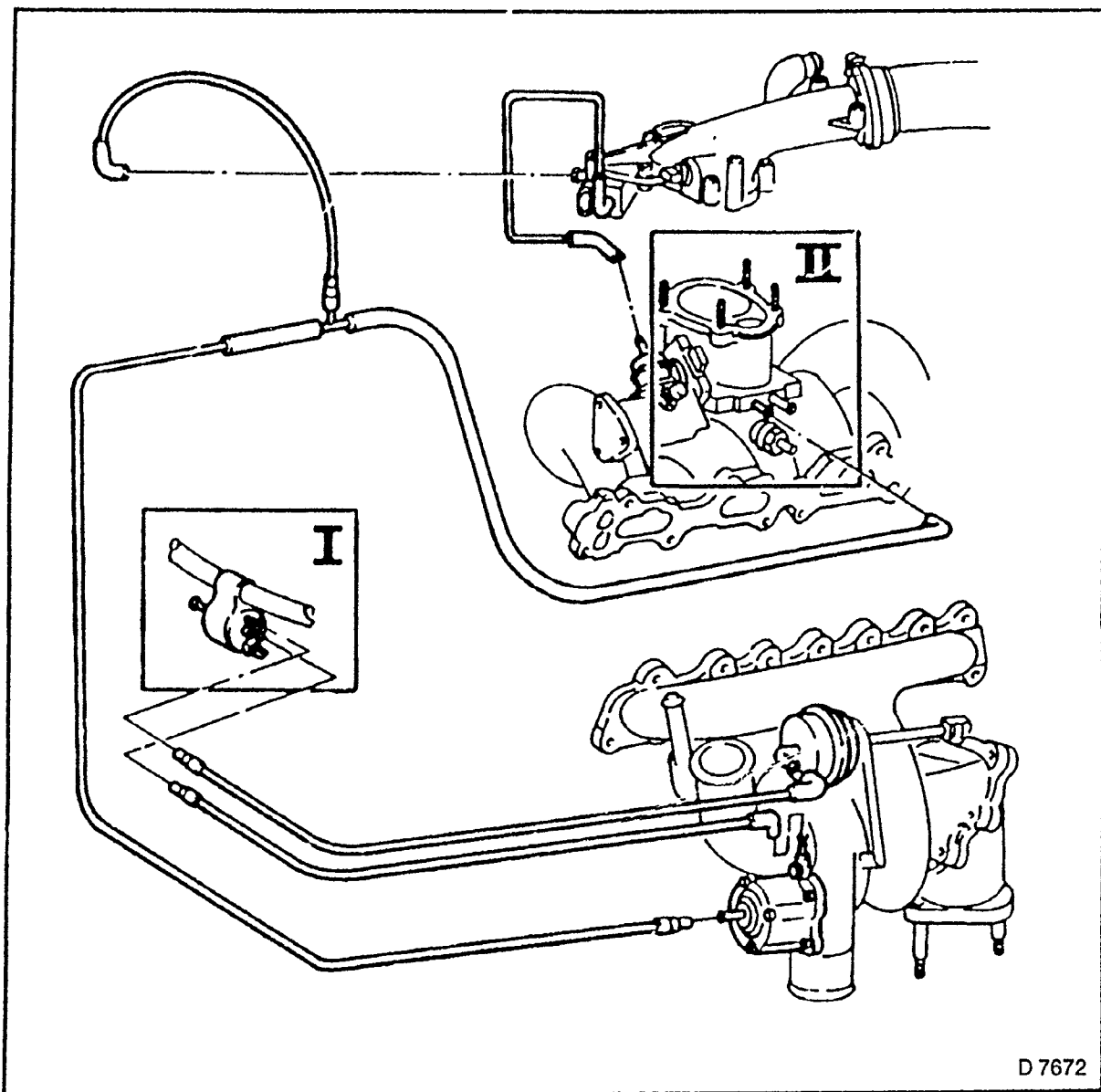
## Turbocharging System (C 20 LET)



D 7974

Fig 582

Engine exhaust side — 2,0 LET



D 7672

Fig. 583

Overall survey of pressure and vacuum hoses.

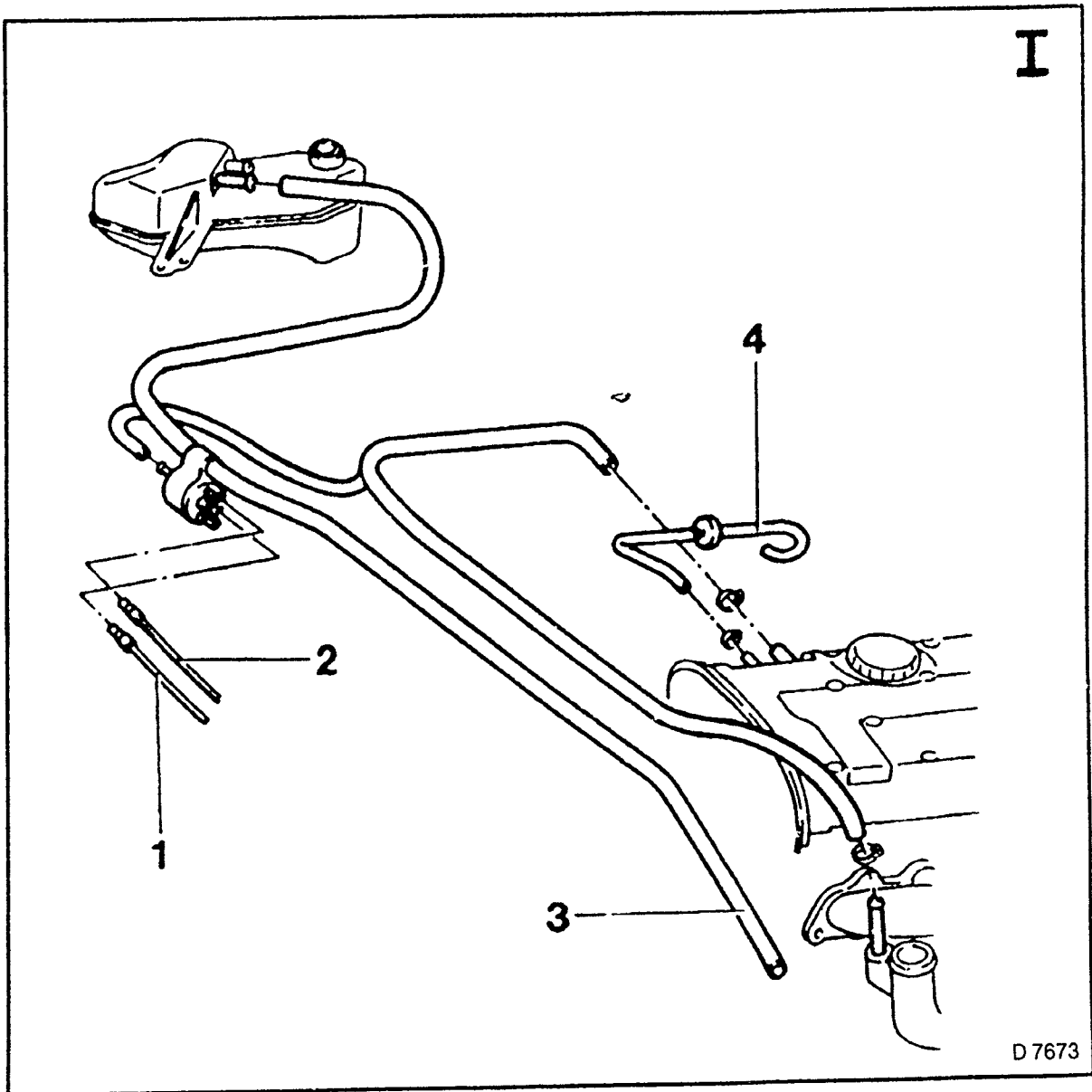


Fig 584

Survey of pressure/vacuum hoses

### ILLUSTRATION 1

1. Connection to air bypass valve.
2. Connection to control unit — charge pressure regulating valve.
3. Turbocharger — coolant return line.
4. Connection to crankcase ventilation.

See local graphics!

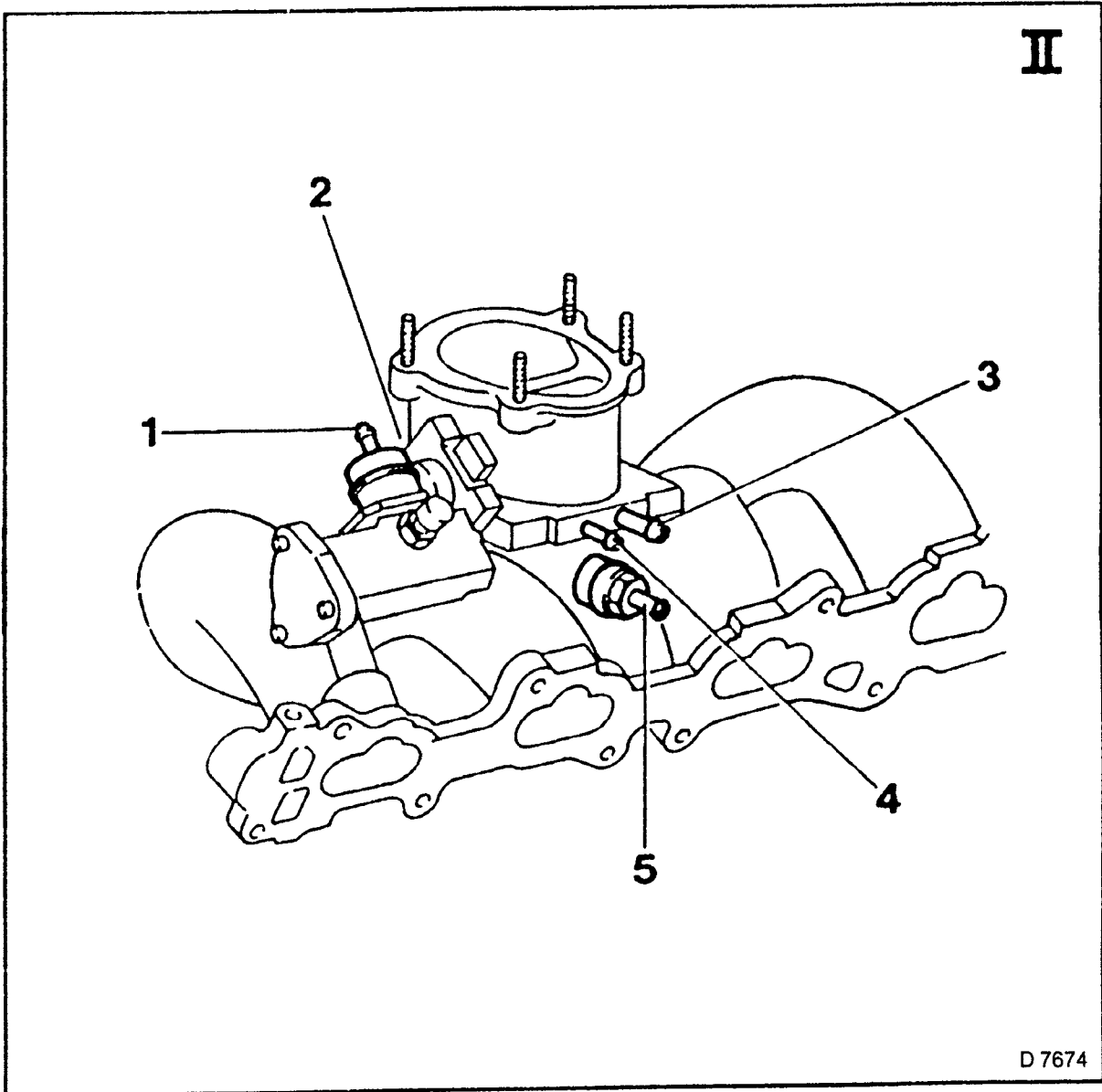


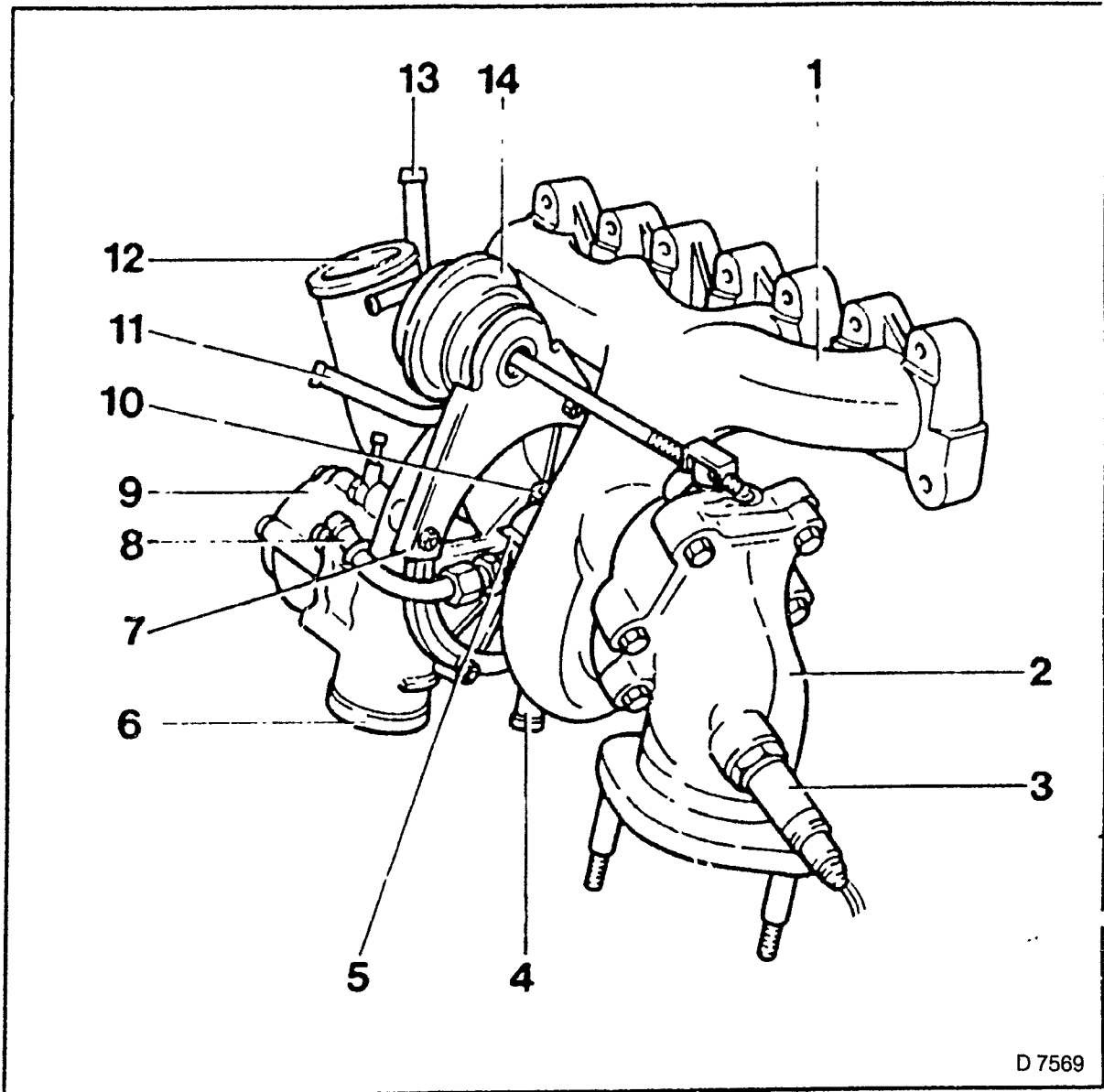
Fig. 585

Survey of pressure/vacuum hoses.

### ILLUSTRATION 2

1. Connection to hot start valve.
2. Connection to control unit.
3. Connection to tank vent valve.
4. Connection to air bypass valve/hot start valve.
5. Connection to crankcase ventilation.





D 7569

Fig. 586

Survey — Turbocharger Attaching Parts.

**ILLUSTRATION 1**

1. Exhaust manifold with integrated turbine casing.
2. Exhaust adapter
3. Oxygen sensor.
4. Oil return.
5. Bearing housing.
6. Pressure side of compressor housing.
7. Compressor housing.
8. Coolant feed from radiator.
9. Air bypass valve.
10. Oil feed.
11. Coolant return to compensation tank.
12. Intake side of compressor housing.
13. Connection for engine ventilation.
14. Control unit with actuating rod for charge pressure control rod.

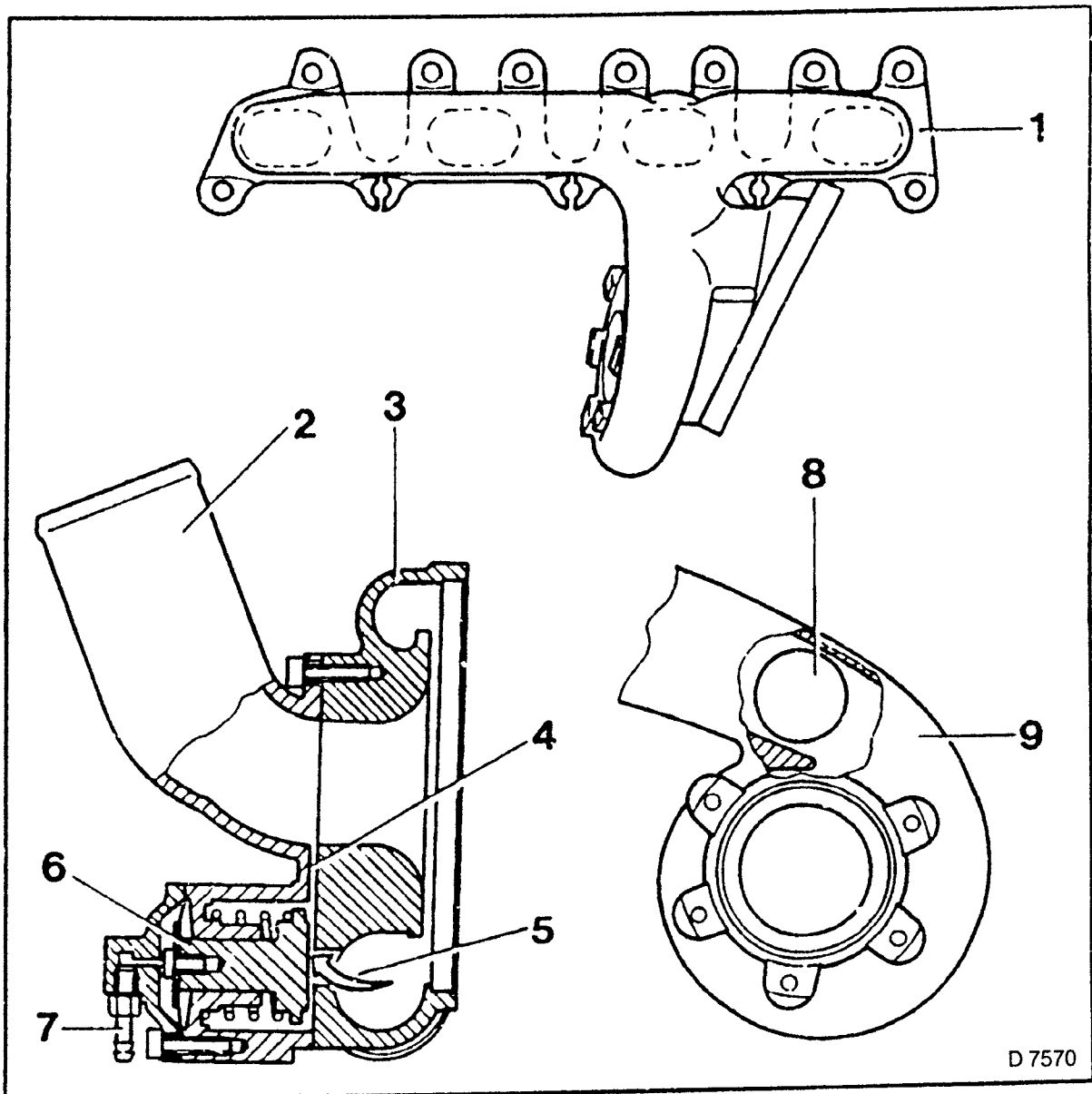
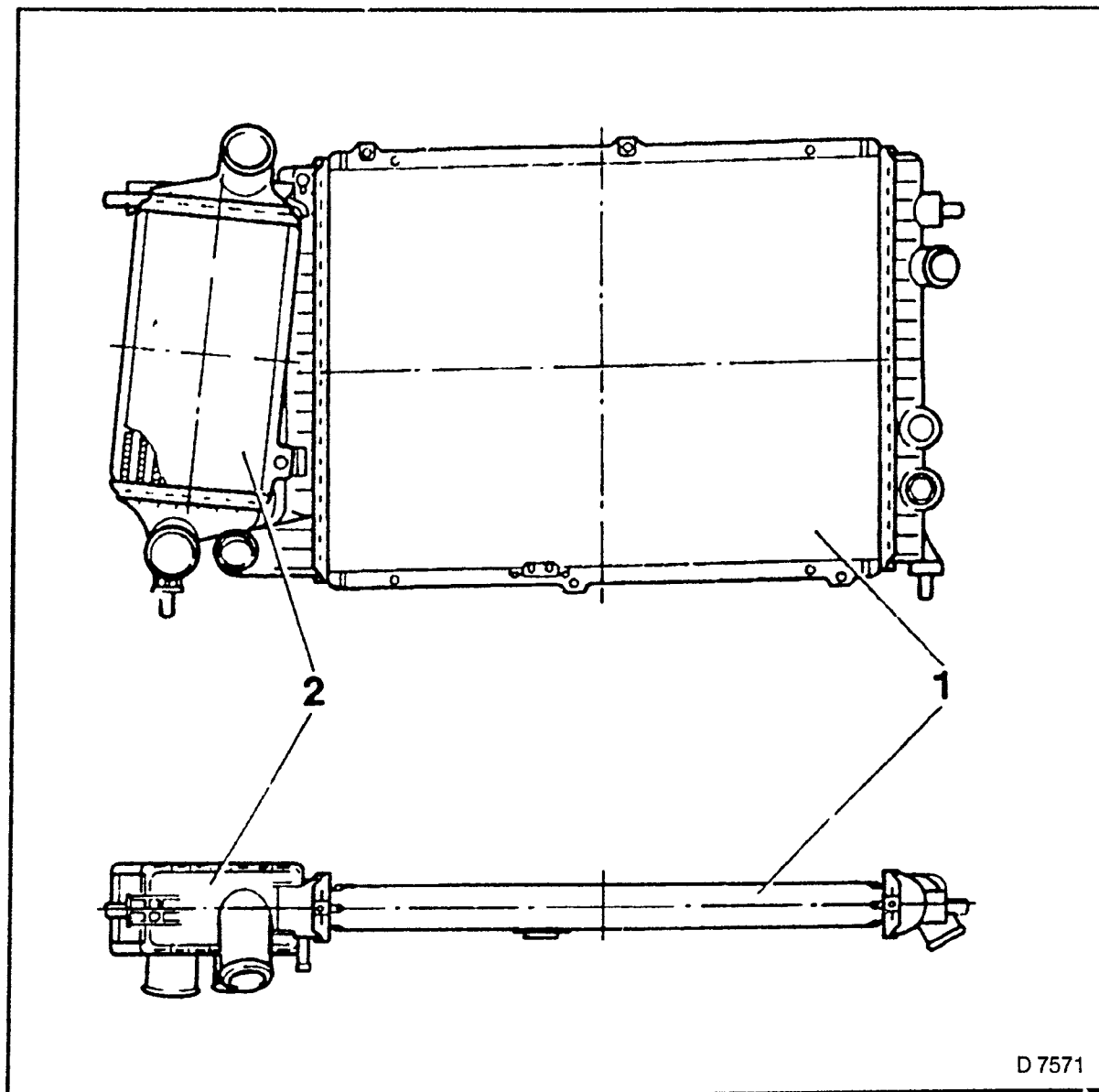


Fig. 587

Survey — Turbocharger Attaching Parts.

### ILLUSTRATION 2

1. Exhaust manifold with integrated turbine casing.
2. Intake side of compressor housing.
3. Compressor housing.
4. Bypass air channel.
5. Bypass air circulation.
6. Air bypass valve (open).
7. Intake manifold pressure connection.
8. Wastegate channel.
9. Turbine casing.



D 7571

Fig. 588

Survey — Turbocharger Attaching Parts.

### ILLUSTRATION 3

1. Water cooler.
2. Charge cooler.

## RECOMMENDED TORQUE VALUES — TURBOCHARGING SYSTEM

|   | Nm               |
|---|------------------|
| Coolant feed line to turbocharger .....                   | 20               |
| Coolant return line to turbocharger .....                 | 20               |
| Cover plate to cylinder head (M 6 bolts) .....            | 9                |
| Cover to throttle valve manifold .....                    | 5                |
| Exhaust diverter manifold to turbocharger .....           | 20 <sup>2)</sup> |
| Exhaust manifold with turbocharger to cylinder head ..... | 25 <sup>1)</sup> |
| Exhaust pipe to exhaust diverter manifold .....           | 12 <sup>1)</sup> |
| Oil feed line to cylinder block screw connection .....    | 20               |
| Oil feed line to turbocharger .....                       | 12               |
| Oxygen sensor to exhaust diverter manifold .....          | 22               |
| Studs in exhaust diverter manifold .....                  |                  |

<sup>1)</sup> Use new nuts.

<sup>2)</sup> Use new bolts.

## Important Repair Instructions

During all operations on the “Turbocharging System”, ensure that work is carried out with the utmost cleanliness and great care.

For checking of individual components of the turbocharger, use the “Motronic M 2.7” Checking Procedures.

### Note:

All data is collected by the control unit and can be read out using TECH 1.

If the nominal and actual values do not match, the control unit switches to its emergency operation program.

Carry out the following visual checks:

Air-conducting hoses for good condition and correct seat.

Pressure/vacuum hoses correctly connected — see Fig. 583.

Condition of pressure/vacuum hoses.

On operations on oil circuit components — turn over engine without fuel supply and ignition before putting into operation — to build up engine oil pressure. Engine oil filling quantities — see “Technical Data”.

Always cover up turbocharger after removing air hoses.

The extent of repairs to the turbocharger is confined to the operations described hereafter.

Replacement of single components is not permitted.

## Coolant Return Line (Turbocharger) — Remove and Install

### REMOVE, DISCONNECT

1. Heat shield from cylinder head.
2. Intake hose.
3. Hosed bracket from hot-wire mass air flow meter.
4. Engine vent hose from turbocharger.
5. Timing hoses.
6. Coolant feed line.
7. Oil feed and return lines.

For this, see operation "Gasket — Exhaust Manifold/Cylinder Head, Replace", page 273.

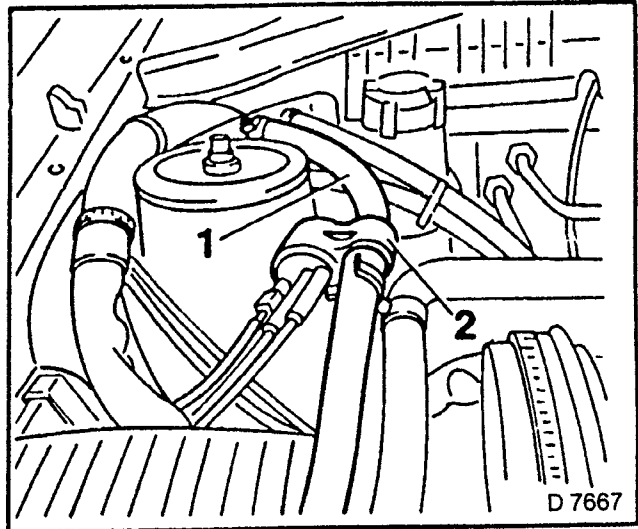


Fig. 589

### REMOVE, DISCONNECT

1. Coolant return line (1) from compensation tank and pull out from rubber bearing (2).

### REMOVE, DISCONNECT

1. Disconnect wiring plug (1) for oxygen sensor. (Where fitted).
2. Front exhaust pipe.
3. Exhaust manifold from head.
4. Exhaust manifold gasket from cylinder head.

### CLEAN

Sealing surfaces of cylinder head and exhaust manifold.

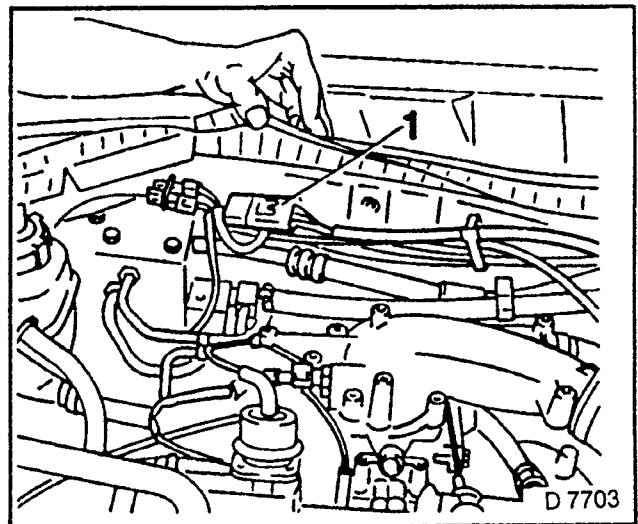


Fig 590

### REMOVE, DISCONNECT

1. Coolant return line (1).
2. Bracket (2) from turbocharger.

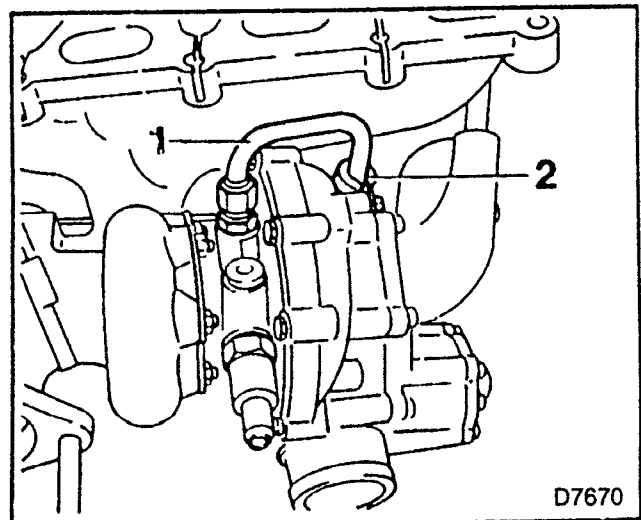


Fig. 591

**INSTALL, CONNECT**

1. Coolant return line (1) and bracket (2) to turbocharger.
2. Exhaust manifold to cylinder head — use new gasket and nuts.

**TIGHTEN (TORQUE)**

1. Exhaust manifold to cylinder head — 25 Nm.
2. Coolant return line to turbocharger — 20 Nm.

**INSTALL, CONNECT**

1. Heat shield to cylinder head.
2. Intake hose.
3. Hose bracket to hot-wire mass air flow meter.
4. Engine vent hose to turbocharger.
5. Timing hoses.
6. Coolant feed line.
7. Oil feed and return lines.

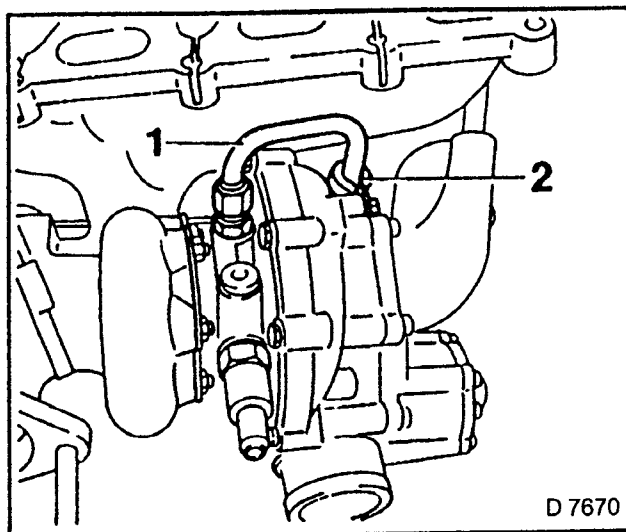


Fig. 592

D 7670

For this, see operation “Gasket — Exhaust Manifold/ Cylinder Head, Replace”, page 273.

**Coolant Feed Line (Turbocharger) — Remove and Install****REMOVE, DISCONNECT**

1. Coolant feed line (1) from turbocharger and water cooler.
2. Collect coolant.

**INSTALL, CONNECT**

1. Coolant feed line to turbocharger and water cooler.
2. Coolant feed line to turbocharger — 20 Nm.
3. Top up and bleed cooling system.

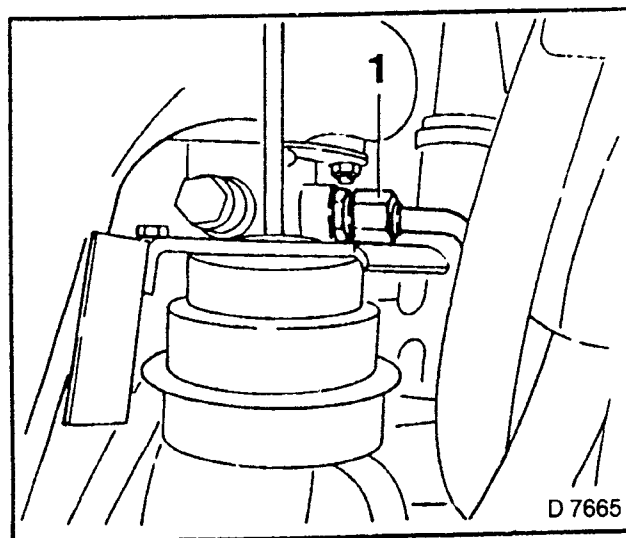


Fig. 593

D 7665

**Charge Cooler — Remove and Install****REMOVE, DISCONNECT**

1. Water cooler.
2. Charge cooler from water cooler.

**INSTALL, CONNECT**

1. Charge cooler to water cooler.
2. Water cooler.
3. Top up and bleed cooling system.

## Water Cooler — Remove and Install

### REMOVE, DISCONNECT

1. Ground cable from battery.
2. Wiring plug from fan motor.
3. Coolant hose.
4. Water cooler/turbocharger.
5. Remove fan motor with fan shroud upwards.

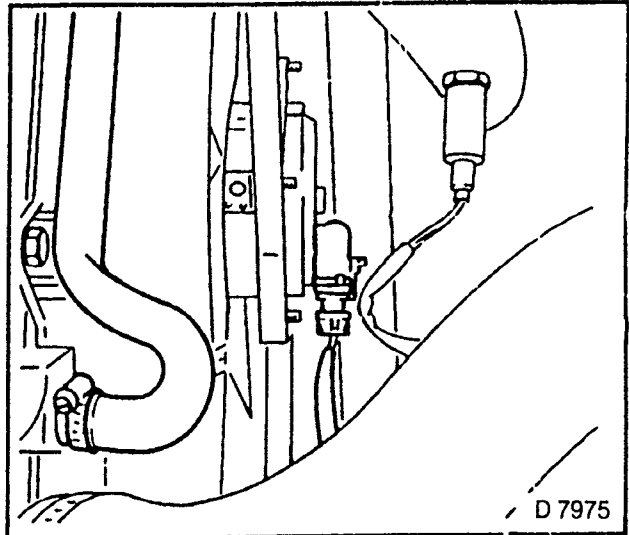


Fig. 594

### REMOVE, DISCONNECT

1. Air hoses from charge cooler.
2. Coolant hoses from water cooler — collect coolant.
3. Wiring plug from temperature sensor.

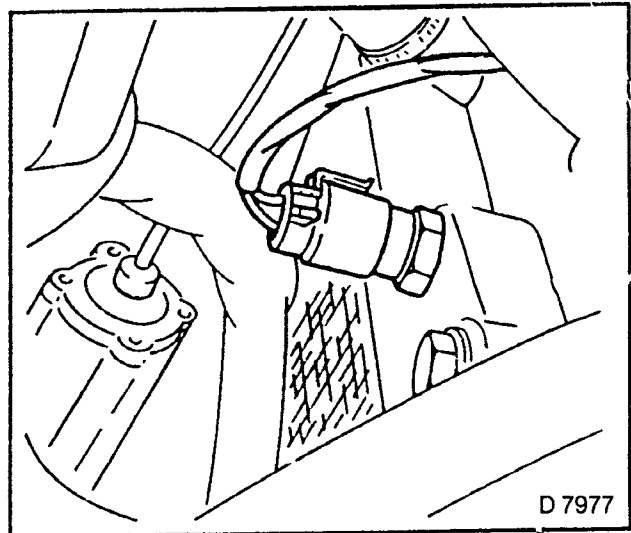


Fig 595

### INSTALL, CONNECT

1. Coolant hose.
2. Water cooler/turbocharger.
3. Wiring plug to fan motor.
4. Ground cable to battery.
5. Top up and bleed cooling system.

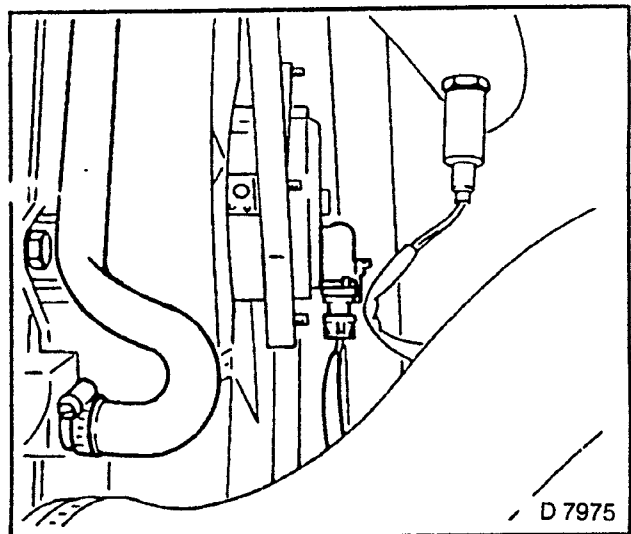


Fig 596

## Oil Return Line (Turbocharger) — Remove and Install

### REMOVE, DISCONNECT

1. Oil return line.
2. Place collecting basin underneath.  
Note escaping oil.

### INSTALL, CONNECT

1. Oil return line.
2. Check engine oil level, correct if necessary.

## Oil Feed Line (Turbocharger) — Remove and Install

### REMOVE, DISCONNECT

1. Oil feed line.  
Note escaping oil.

### INSTALL, CONNECT

1. Oil feed line — replace seal rings.
2. Oil feed line to turbocharger — 12 Nm.
3. Oil feed line to cylinder block screw connection — 20 Nm.
4. Check engine oil level, correct if necessary.

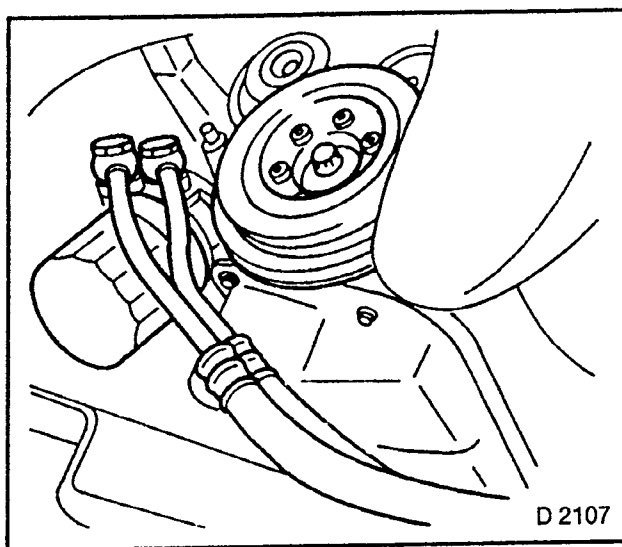


Fig. 597

## Gasket — Exhaust Manifold/Cylinder Head — Replace

### REMOVE, DISCONNECT

1. Heat shield from cylinder head. Intake hose (1).
2. Engine vent hose from turbocharger.

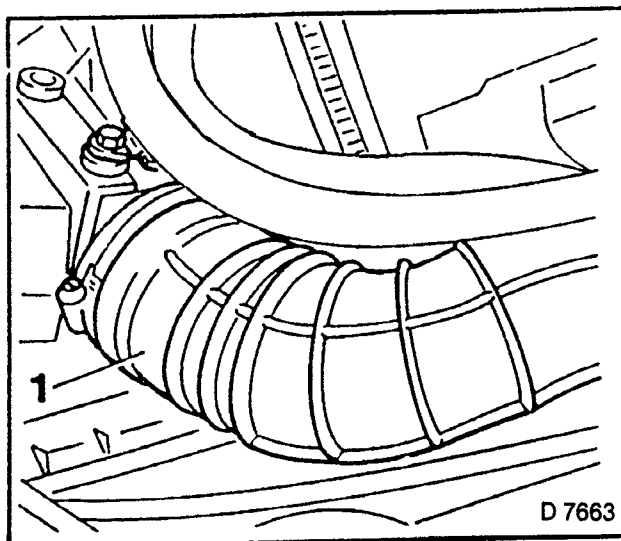


Fig. 598

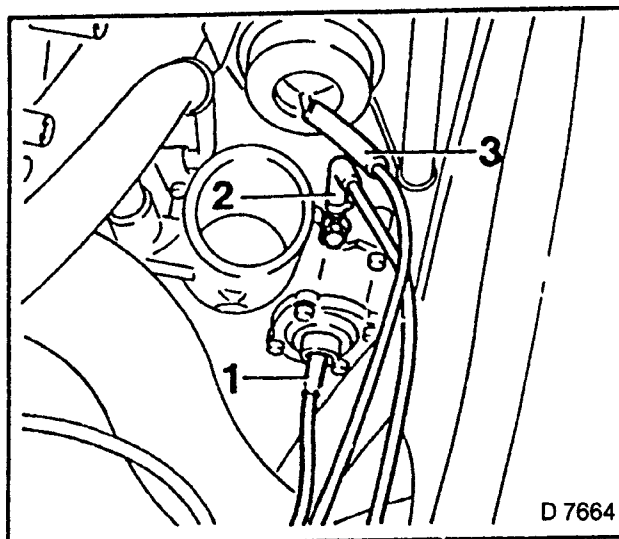


**REMOVE, DISCONNECT**

Timing hoses (1), (2) and (3). from turbocharger.

**NOTE:**

**MARK TIMING HOSES BEFORE REMOVAL. SURVEY OF CONNECTIONS — SEE FIG. 583.**

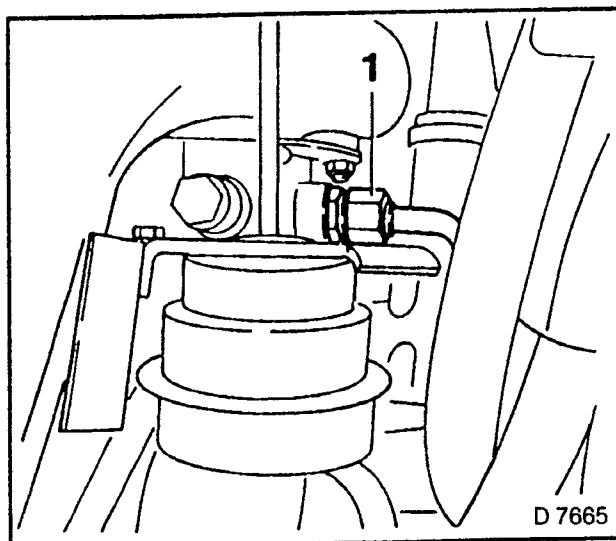


D 7664

Fig. 599

**REMOVE, DISCONNECT**

- 1. Coolant feed line (1) from turbocharger.
- 2. Place collecting basin underneath.
- 3. Collect coolant.

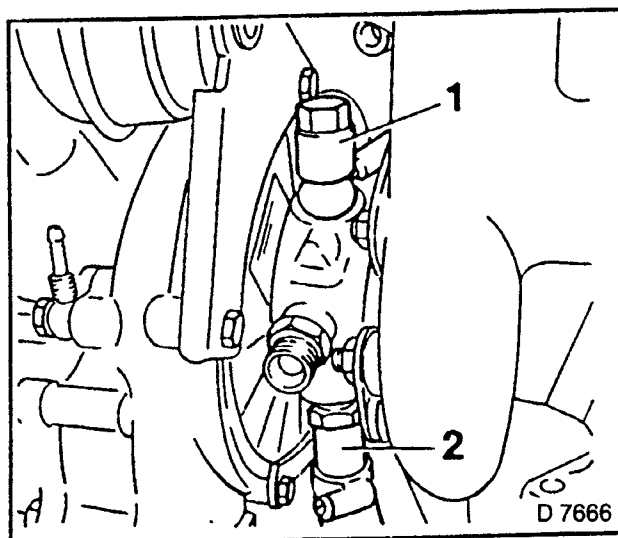


D 7665

Fig. 600

**REMOVE, DISCONNECT**

- 1. Oil feed line (1).
- 2. Oil return line (2) from turbocharger
- 3. Note escaping oil.
- 4. Close off oil lines



D 7666

Fig. 601

**REMOVE, DISCONNECT**

1. Coolant return line (1) from compensation tank and pull out of rubber bearing (2).

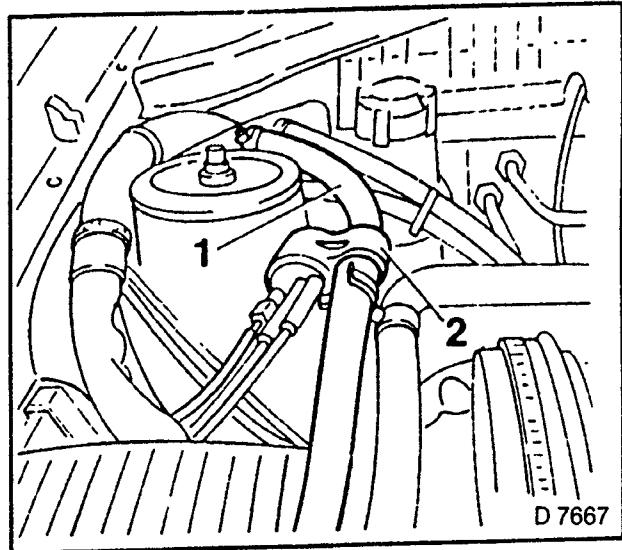


Fig. 602

**REMOVE, DISCONNECT**

1. Front exhaust pipe from exhaust adapter.

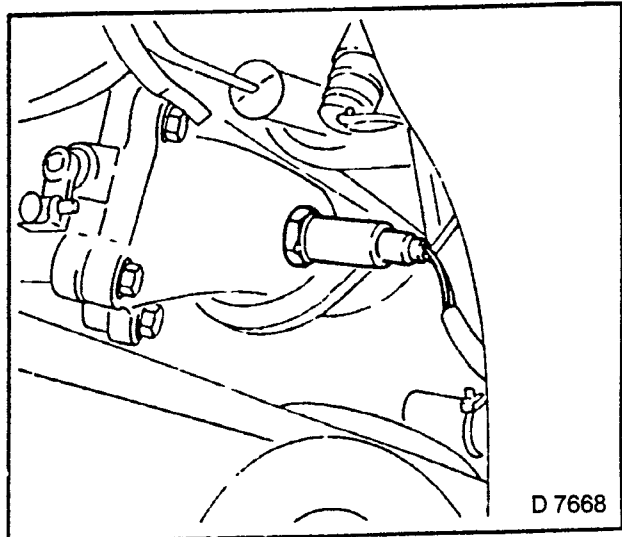


Fig. 603

**REMOVE, DISCONNECT**

1. Exhaust manifold from cylinder head.
2. Exhaust manifold gasket from cylinder head.

**CLEAN**

1. Sealing surfaces of cylinder head and exhaust manifold.

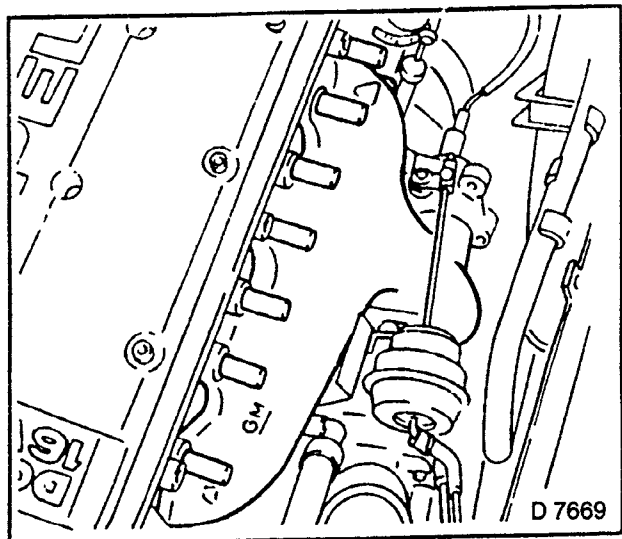


Fig. 604

**REMOVE, DISCONNECT**

- 1. Coolant return line (1).
- 2. Bracket (2) from turbocharger.
- 3. If the exhaust manifold is replaced with the turbocharger, the exhaust adapter must be transferred — use new bolts.

Exhaust adapter to turbocharger  
 — 20 Nm.

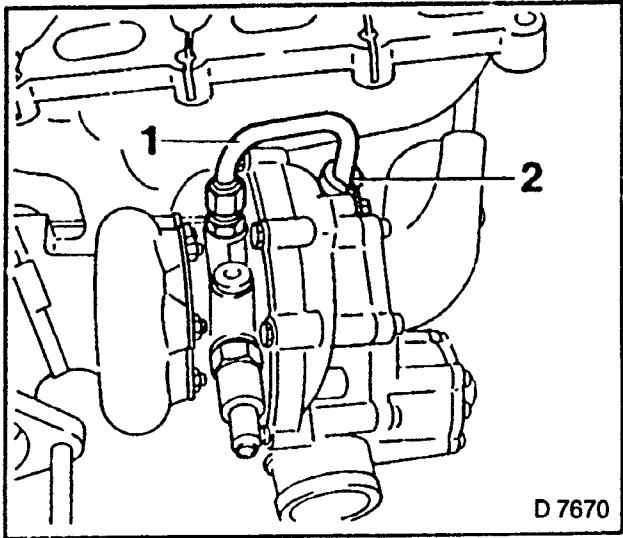


Fig. 605

D 7670

**INSTALL, CONNECT**

- 1. Coolant return line (1).
- 2. Bracket (2) to turbocharger.
- 3. Exhaust manifold to cylinder head — use new gasket and nuts.

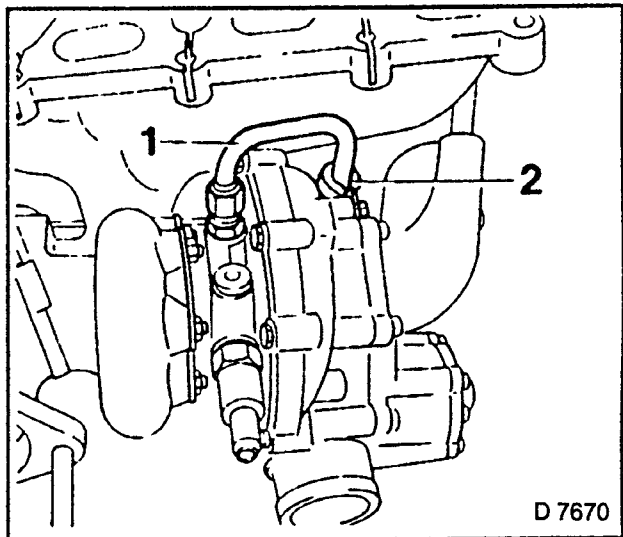


Fig 606

D 7670

**TIGHTEN (TORQUE)**

- 1. Exhaust manifold to cylinder head  
 — 25 Nm.
- 2. Coolant return line to turbocharger  
 — 20 Nm.

**INSTALL, CONNECT**

- 1. Front exhaust pipe to exhaust adapter.

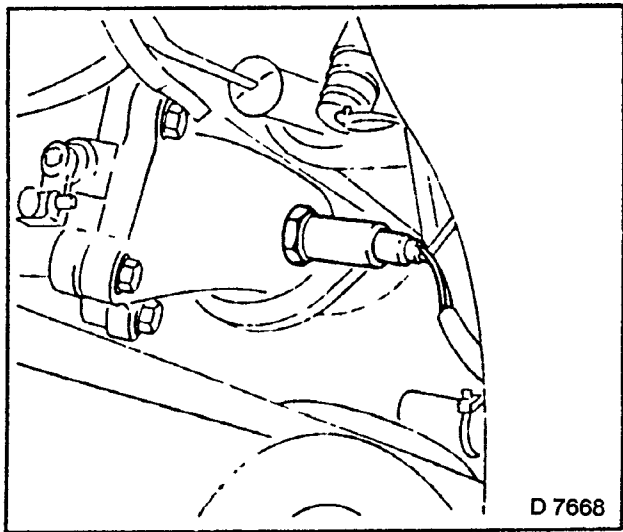


Fig. 607

D 7668

**INSTALL, CONNECT**

1. Oil feed line (1) with new seal rings.
2. Oil return hose to turbocharger.
3. Coolant feed line (2) to turbocharger.
4. Timing hoses to turbocharger.

**NOTE:**

**NOTE MARKS ON TIMING HOSES MADE PREVIOUSLY — SEE ALSO SURVEY OF CONNECTIONS, FIG. 583. OBSERVE ROUTING OF LINES.**

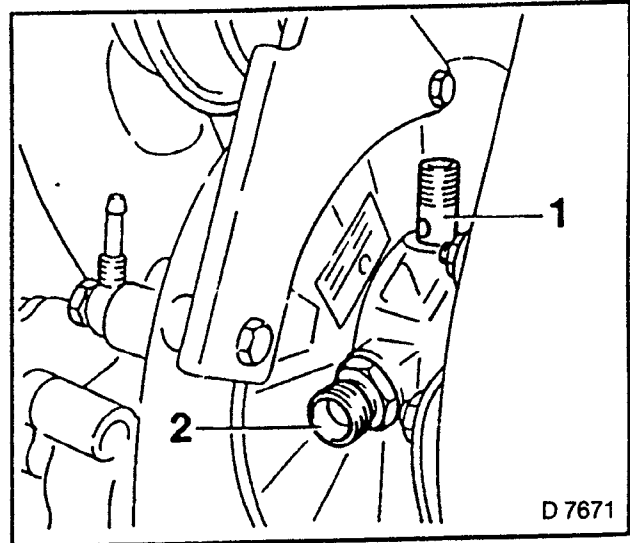


Fig. 608

**INSTALL, CONNECT**

1. Pull coolant return hose (1) through rubber bearing (2).
2. Coolant return hose to compensation tank.

**TIGHTEN (TORQUE)**

1. Oil feed line to turbocharger — 12 Nm.
2. Coolant feed line to turbocharger — 20 Nm.

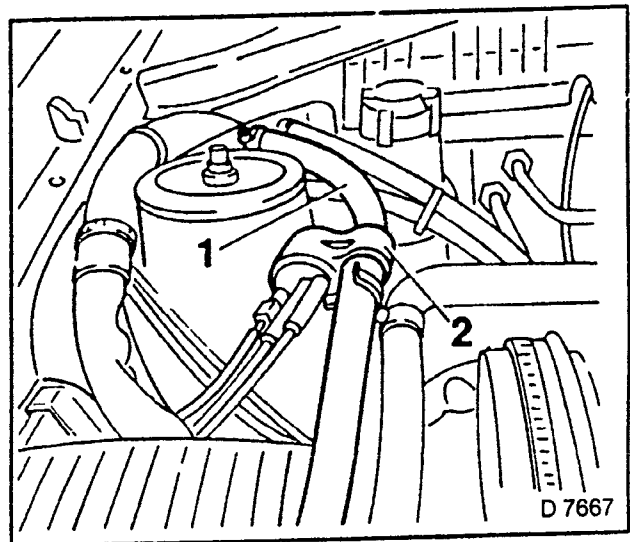


Fig 609

**INSTALL, CONNECT**

1. Heat shield to cylinder head — 9 Nm.
2. Engine vent hose to turbocharger.
3. Intake hose (1) and hose bracket (2) to hot-wire mass air flow meter.
4. Top up and bleed cooling system.
5. Check engine oil level, correct if necessary.

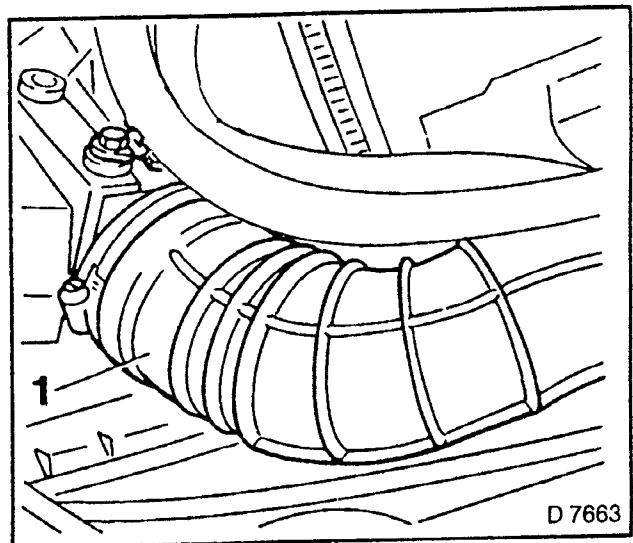
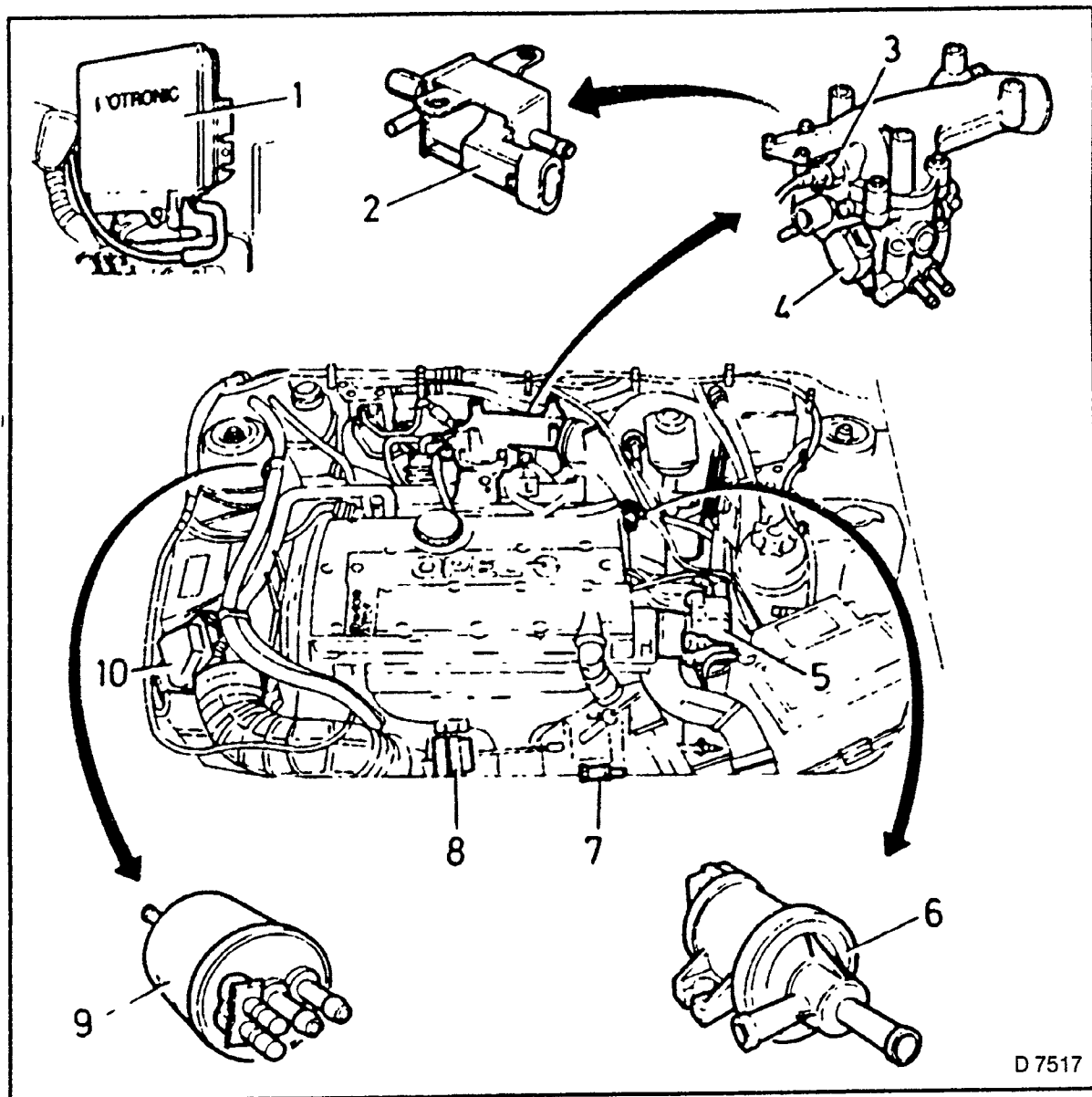


Fig. 610



D 7517

Fig. 611

### MOTRONIC M 2.7 (C 20 LET) INJECTION SYSTEM

1. Control unit  
(installation position: right footwell).
2. Hot start valve.
3. Intake air temperature sensor.
4. Throttle valve potentiometer.
5. High voltage distributor with integrated Hall sensor.
6. Tank vent valve (N/a to Delta).
7. Oxygen sensor.
8. Control unit — charge pressure control valve.
9. Bypass valve — charge pressure control.
10. Hot-wire mass air flow meter.



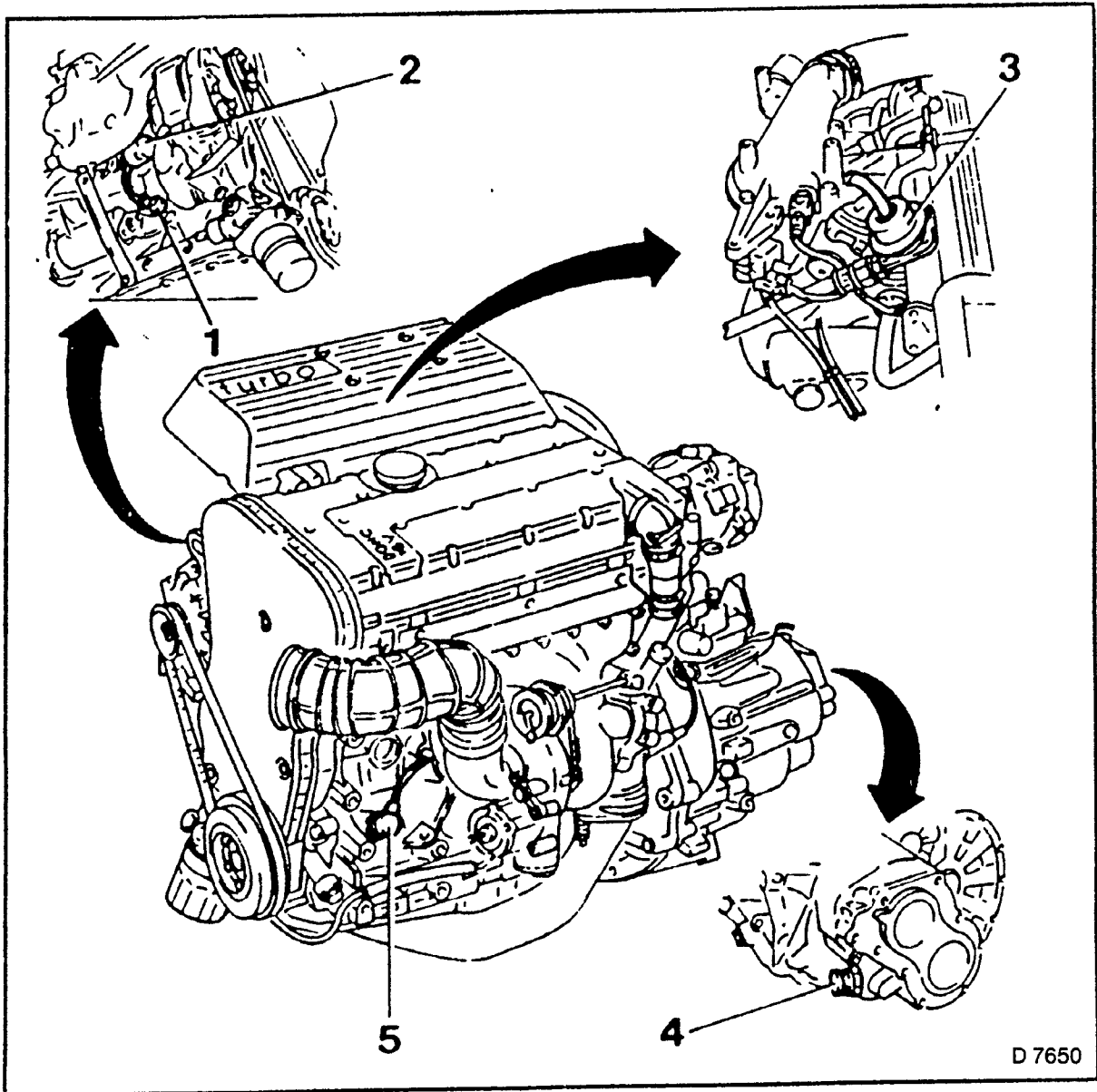


Fig. 612

**MOTRONIC M 2.7 (C 20 LET)  
INJECTION SYSTEM**

- 1. Knock sensor.
- 2. Idle speed adjuster.
- 3. Fuel pressure regulator.
- 4. 1st gear recognition switch.
- 5. Inductive pulse pick-up.

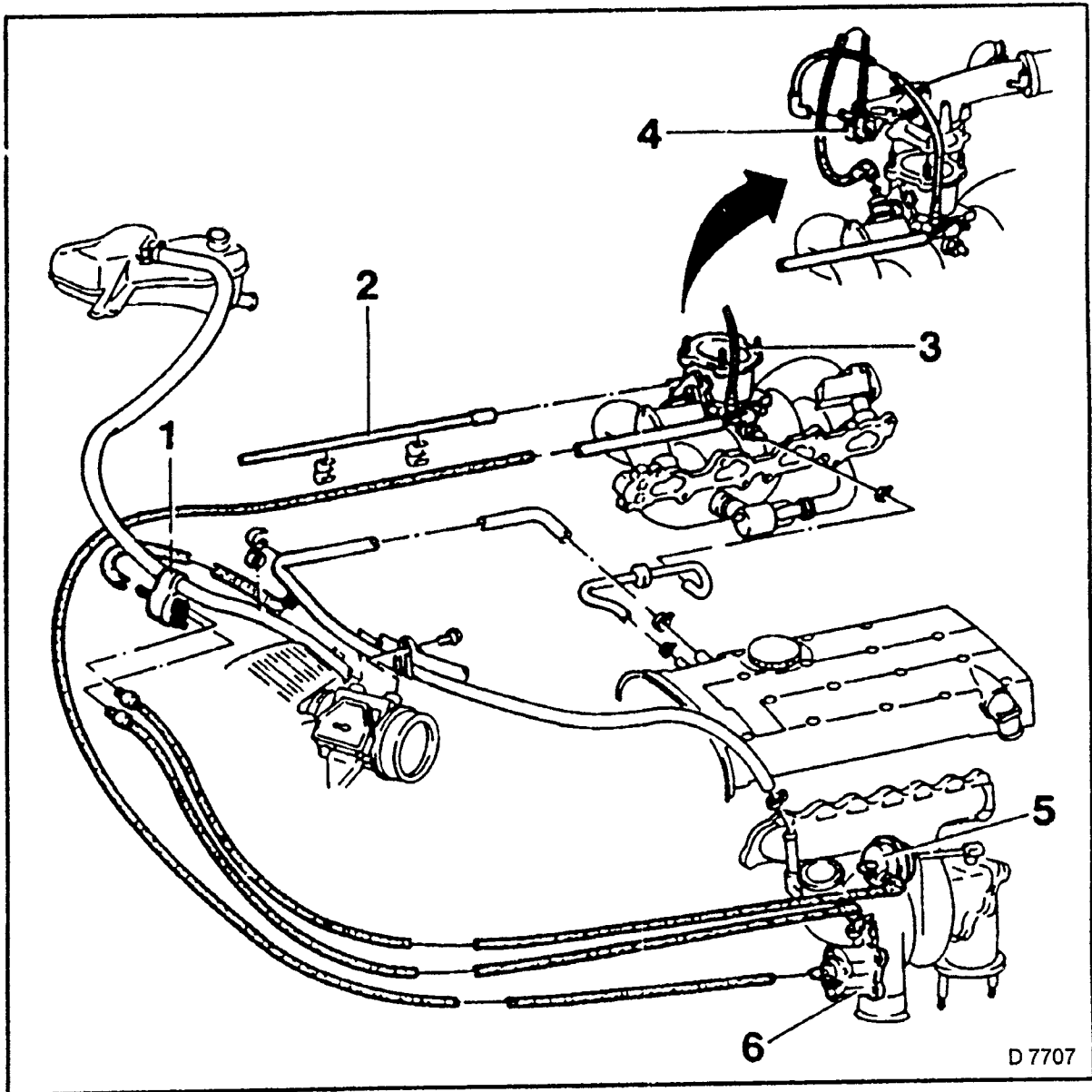


Fig. 613

### MOTRONIC M 2.7 (C 20 LET) INJECTION SYSTEM

1. Bypass valve — charge pressure control.
2. Connection to M 2.7 control unit.
3. Throttle body.
4. Hot start valve.
5. Control unit — charge pressure control valve.
6. Air bypass valve.

## Throttle Body — Remove and Install

### REMOVE, DISCONNECT

1. Cover for throttle valve manifold.
2. Hoses (1) and (2) from throttle valve manifold.

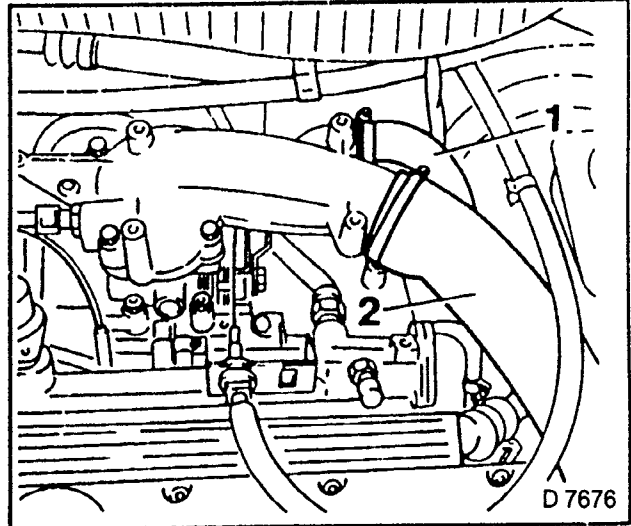


Fig. 614

### REMOVE, DISCONNECT

1. Mark vacuum hoses.
2. Wiring plug (1) for intake air temperature sensor.
3. Wiring plug and vacuum hoses from hot start valve (2).

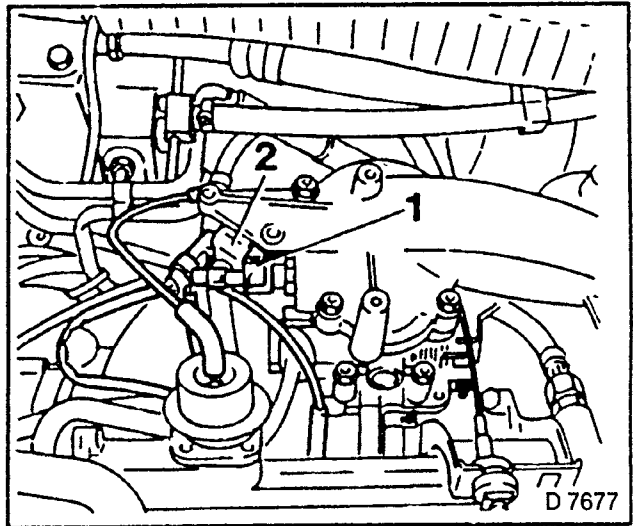


Fig 615

### REMOVE, DISCONNECT

1. Throttle valve manifold (1) with gasket.

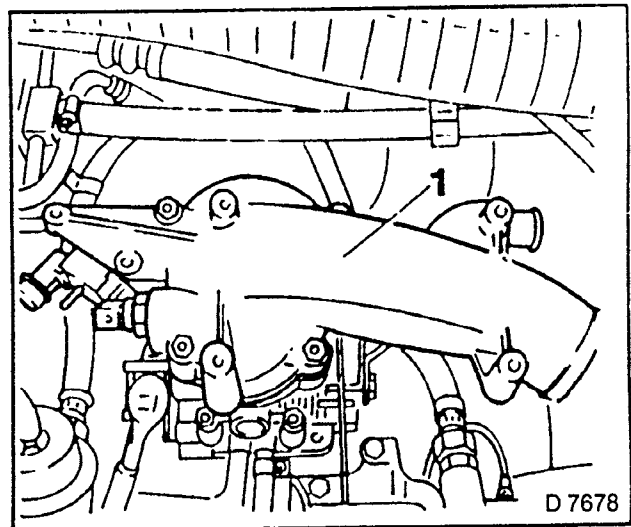


Fig 616



**REMOVE, DISCONNECT**

2. Wiring plug (1) from throttle valve potentiometer.
3. Pressure/vacuum hose (2) from throttle body.

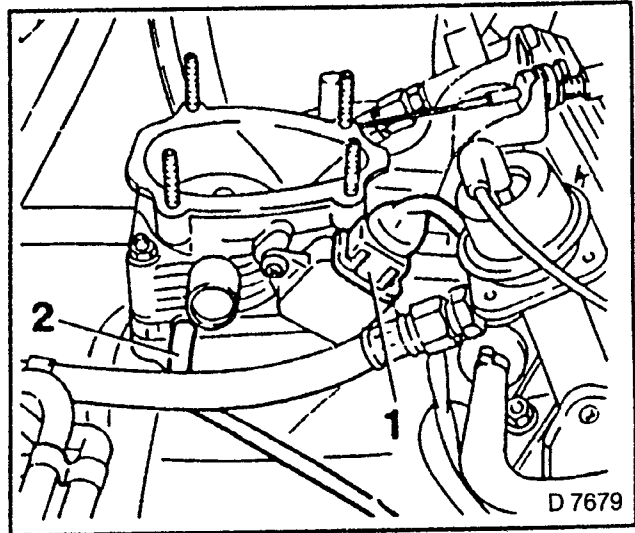


Fig. 617

**REMOVE, DISCONNECT**

1. Pressure/vacuum hoses (1). and (2) from throttle body.

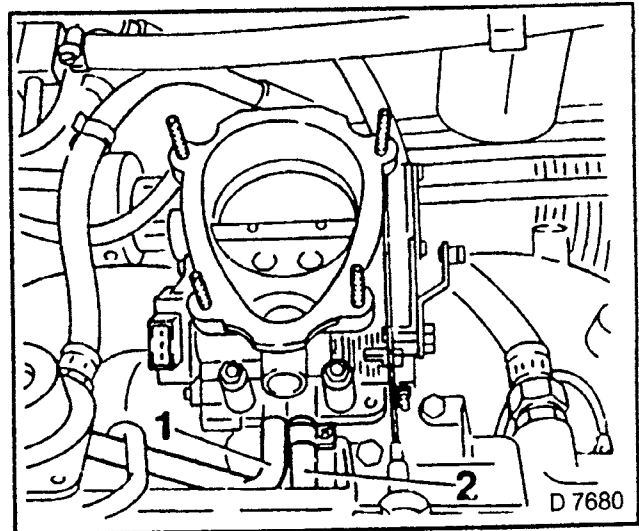


Fig. 618

**REMOVE, DISCONNECT**

1. Bowden cable (1).
2. Fuel line bracket (2).

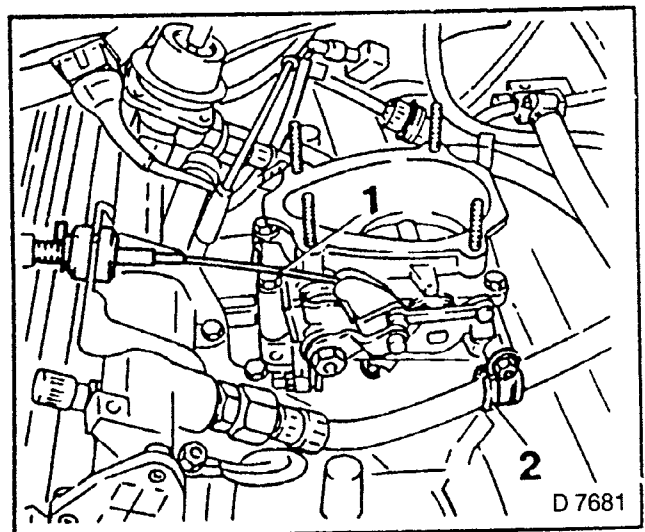


Fig. 619

**REMOVE, DISCONNECT**

- 1. Nuts (1) from throttle body.
- 2. Throttle body with gasket.

**CLEAN**

Sealing surfaces between throttle body and intake manifold.  
Observe utmost cleanliness.

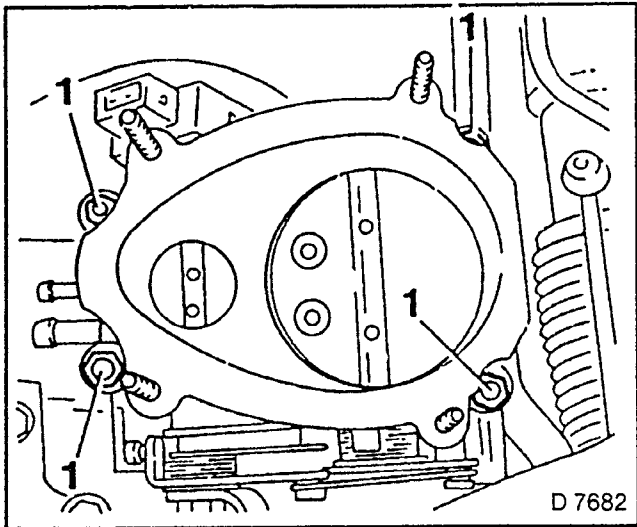


Fig. 620

D 7682

**INSTALL, CONNECT**

- 1. Throttle body with new gasket — tightening torque 9 Nm.

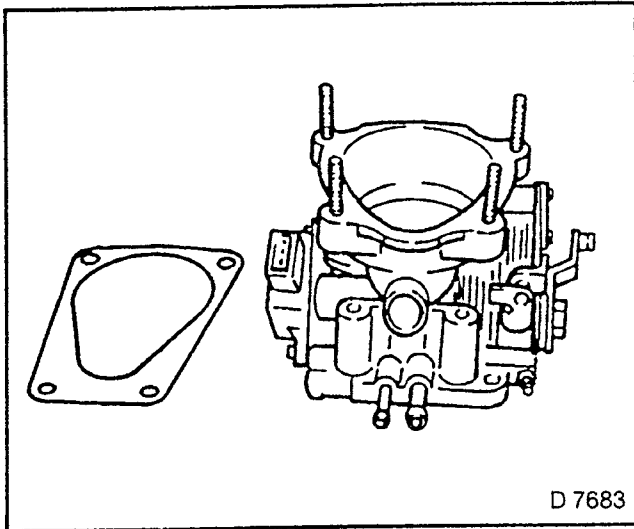


Fig. 621

D 7683

**INSTALL, CONNECT**

- 1. Bowden cable (1).
- 2. Fuel line bracket (2).

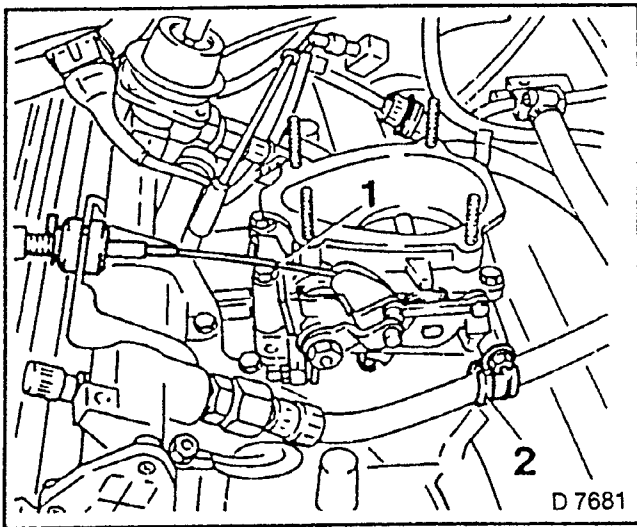


Fig. 622

D 7681

**INSTALL, CONNECT**

1. Pressure/vacuum hoses (1) & (2) to throttle body.

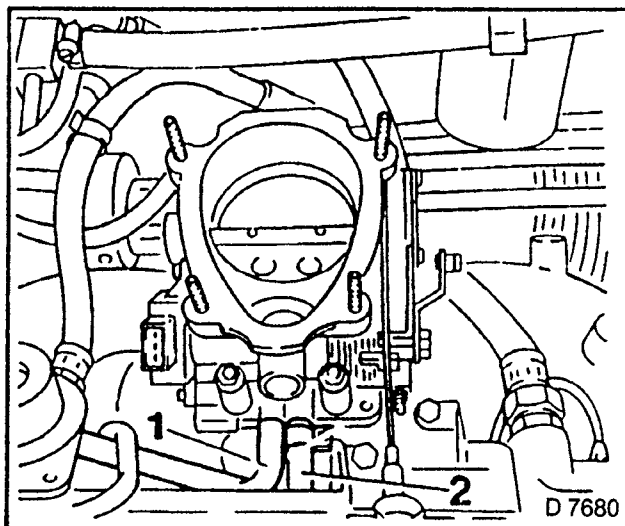


Fig. 623

**INSTALL, CONNECT**

1. Wiring plug (1) for throttle valve potentiometer.
2. Pressure/vacuum hose (2) to throttle body.

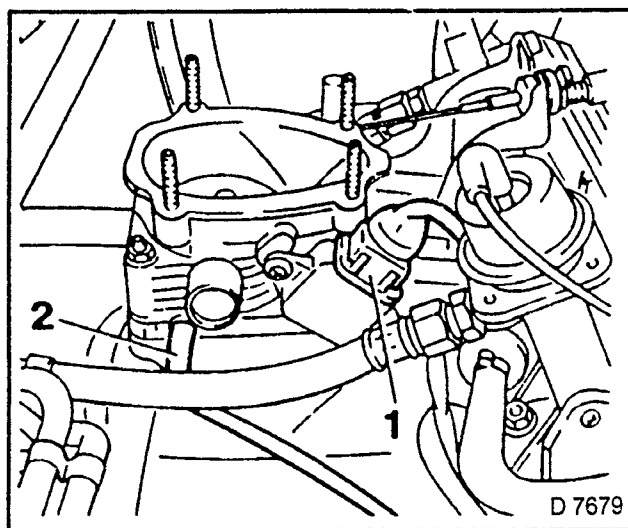


Fig. 624

**THROTTLE BODY CONNECTION**

- 1 = Connection to control unit M 2.7
- 2 = Connection to branch piece.
- 3 = Connection to tank vent valve.

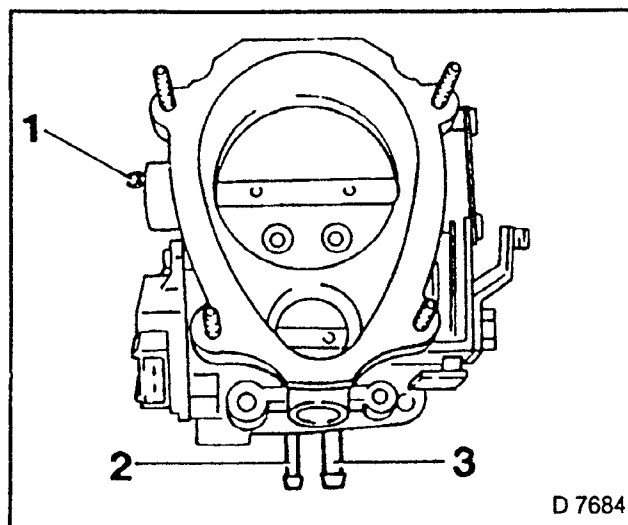


Fig. 625

**BRANCH PIECE CONNECTION**

- 1 = Connection to hot start valve.
- 2 = Connection to air bypass valve, turbocharger.

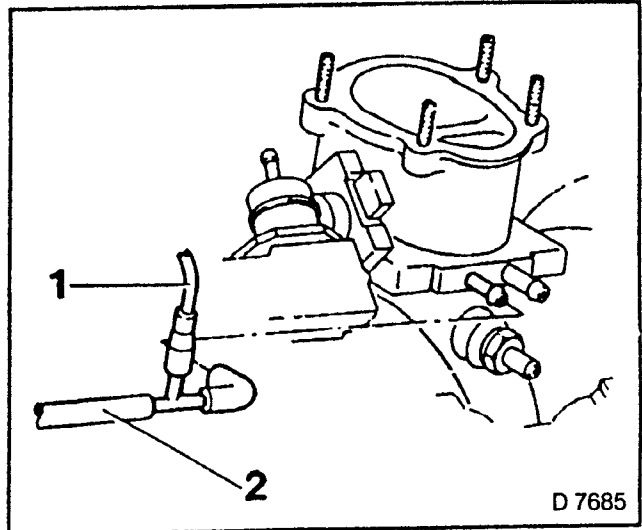


Fig. 626

**INSTALL, CONNECT**

- 1. Throttle valve manifold (1) with new gasket — tightening torque 8 Nm.

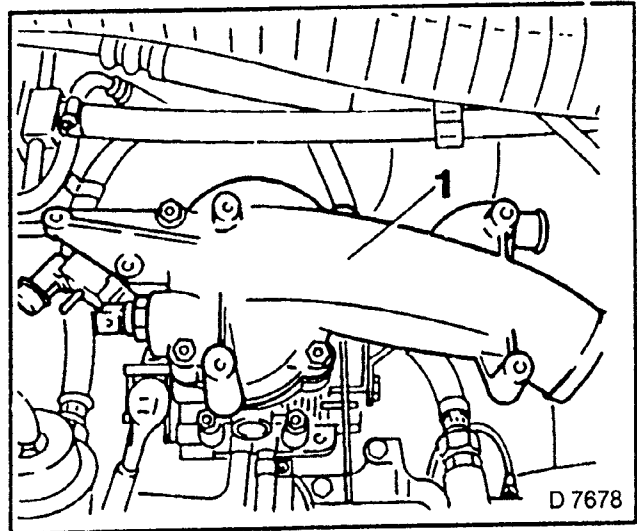


Fig. 627

**INSTALL, CONNECT**

- 1. Pressure/vacuum hose to branch piece.
- 2. Vacuum hoses and wiring plug to hot start valve (2).
- 3. Wiring plug (1) for intake air temperature sensor.
- 4. Hose for idle speed adjuster and for charge cooler to throttle valve manifold.
- 5. Throttle valve manifold cover — tightening torque 5 Nm.

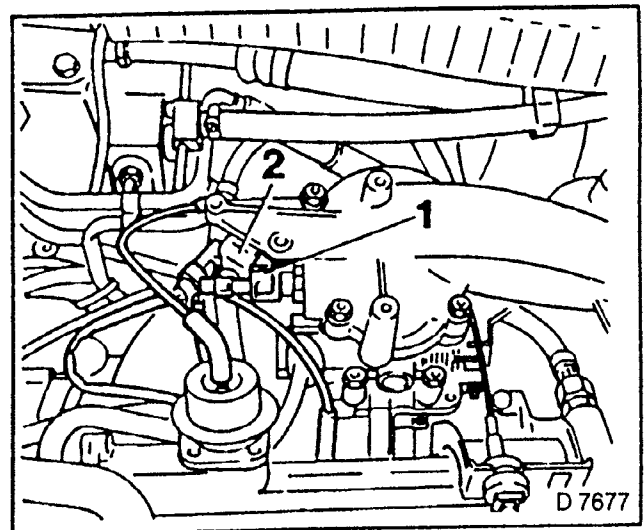


Fig. 628

## Throttle Valve Potentiometer — Remove and Install

For a clearer representation, Fig. 583 shows the throttle valve potentiometer with the throttle valve manifold removed.

### REMOVE, DISCONNECT

1. Throttle valve manifold cover.
2. Wiring plug for throttle valve potentiometer.
3. Throttle valve potentiometer (1).

### INSTALL, CONNECT

1. Throttle valve potentiometer (1).
2. Wiring plug for throttle valve potentiometer.
3. Throttle valve manifold cover.

### TIGHTEN (TORQUE)

1. Throttle valve manifold cover to throttle body 5 Nm.

## Injection Valves — Remove and Install

### REMOVE, DISCONNECT

1. Throttle valve manifold cover.
2. Bowden cable (1).
3. Crankcase ventilation hoses (2) and (3).

### REMOVE, DISCONNECT

1. Retaining clamp (1) from 1st cylinder injection valve from plug strip.
2. Remove plug strip.
3. Insert retaining clamp (1) in plug strip.

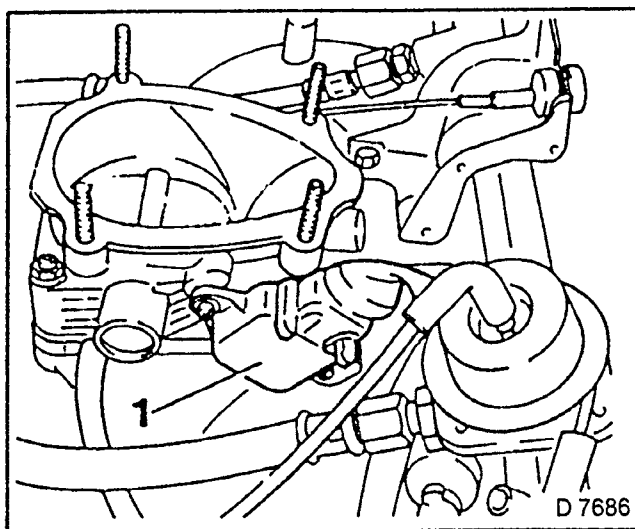


Fig. 629

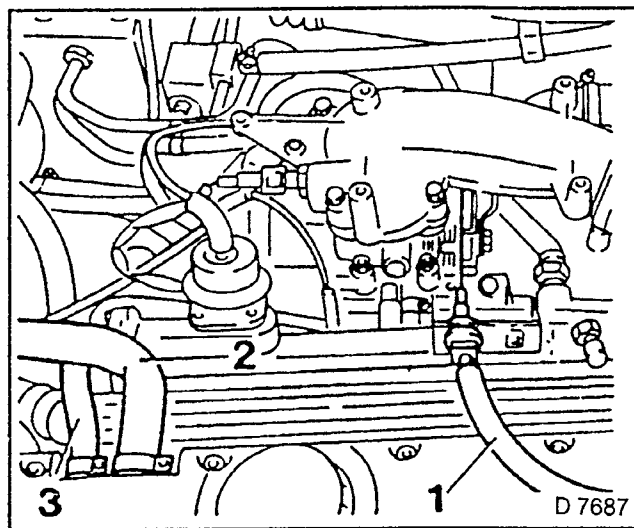


Fig. 630

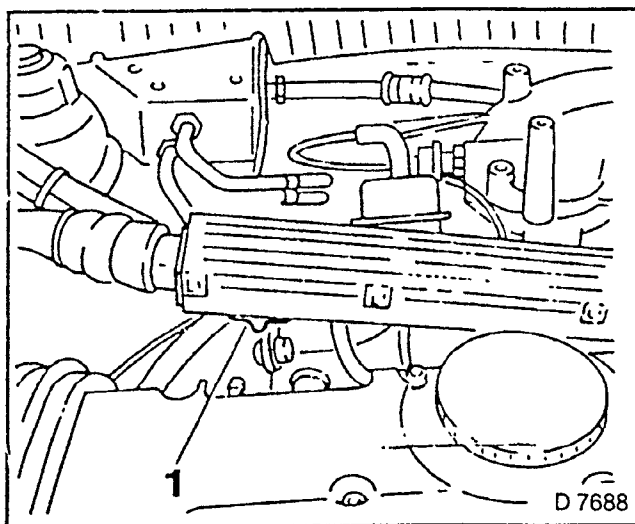


Fig. 631

**REMOVE, DISCONNECT**

1. Bowden cable bracket (1).
2. Ground cable (2).

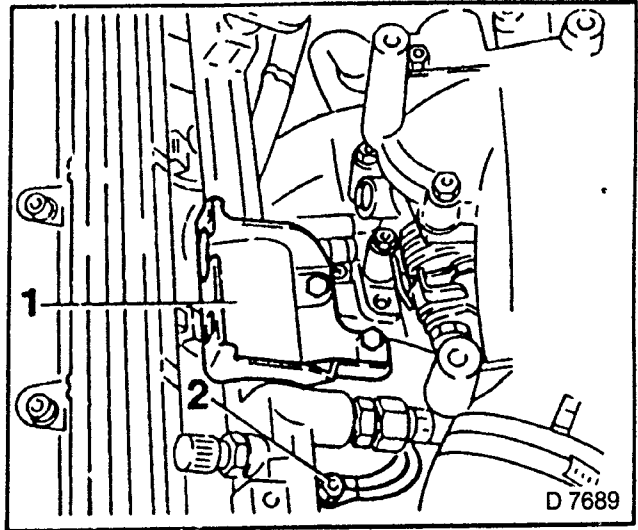


Fig. 632

**REMOVE, DISCONNECT**

1. Ground cable (1).

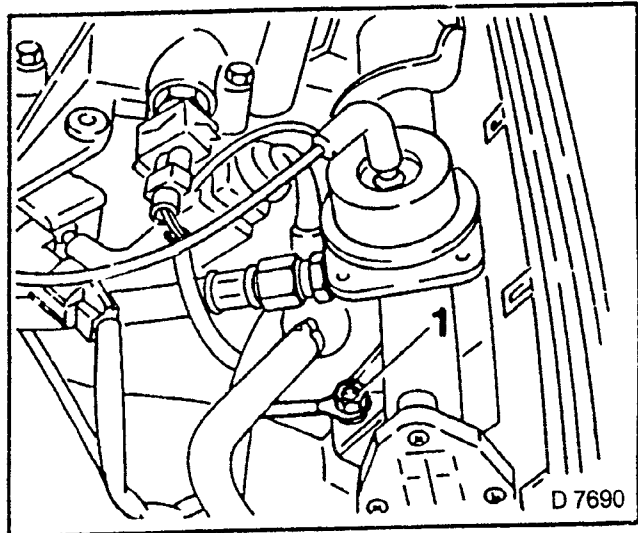


Fig. 633

**REMOVE, DISCONNECT**

1. Fuel distributor pipe.
2. Fuel distributor pipe with injection valves from intake manifold.
3. Spring clamp.
4. Injection valves from fuel distributor pipe.

**WARNING:**

**FUEL ESCAPES  
OBSERVE SAFETY MEASURES AND  
NATIONAL REGULATIONS.**

**INSTALL, CONNECT**

1. Injection valve with new seal rings in fuel distributor pipe.
2. Spring clamp.

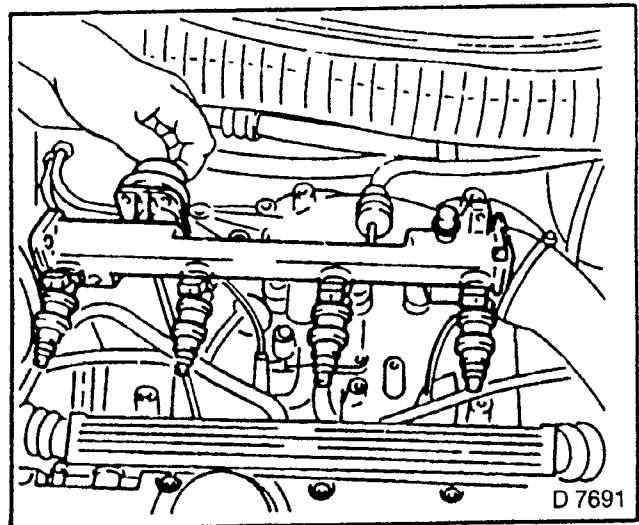


Fig. 634

**INSTALL, CONNECT**

1. Fuel distributor pipe with injection valves in intake manifold — ensure correct seating.
2. Ground cables (1) and (2) to fuel distributor pipe.

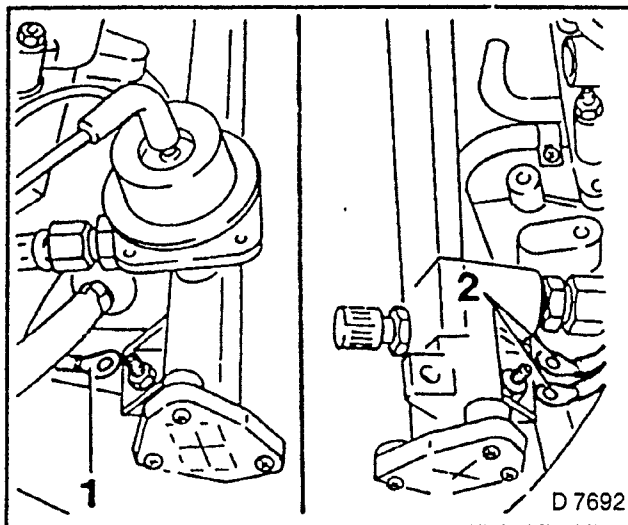


Fig 635

**INSTALL, CONNECT**

1. Bowden cable bracket (1).
2. Plug strip (2) on injection valves.
3. Plug strip must engage audibly — ensure correct seating.

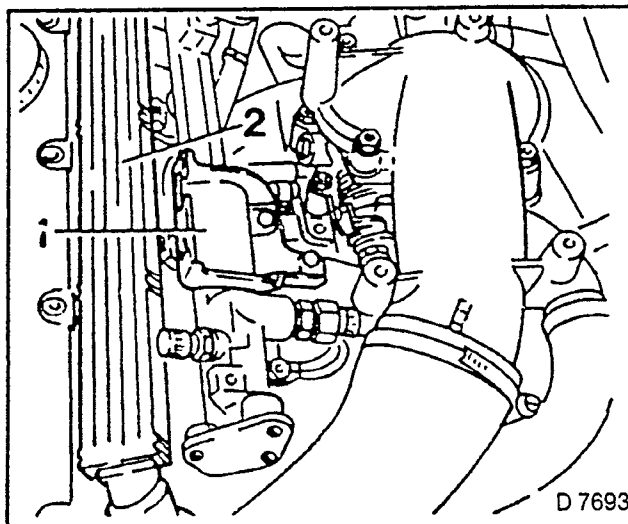


Fig 636

**INSTALL, CONNECT**

1. Attach Bowden cable (1) free of tension.
2. Crankcase ventilation hoses (2) and (3).
3. Throttle valve manifold cover — tightening torque 5 Nm.

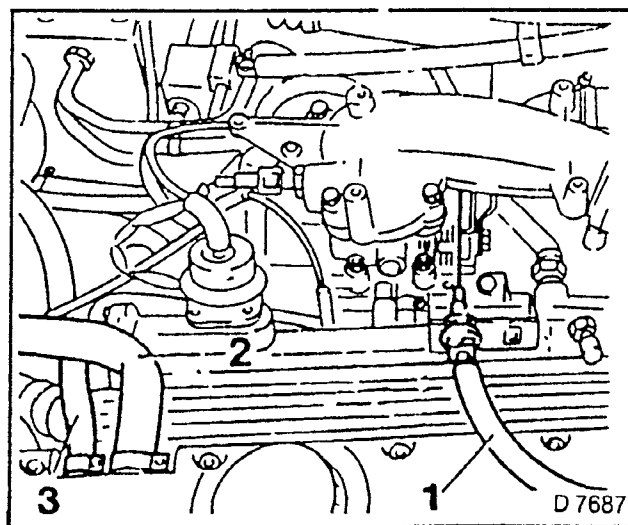


Fig 637

## Hot Start Valve — Remove and Install

See Fig. 583 — Hot start valve with the throttle valve manifold removed.

### REMOVE, DISCONNECT

1. Throttle valve manifold cover.
2. Wiring plug for hot start valve.
3. Vacuum hoses.
4. Hot start valve (1) from throttle valve manifold — if necessary.
5. Remove throttle valve manifold.

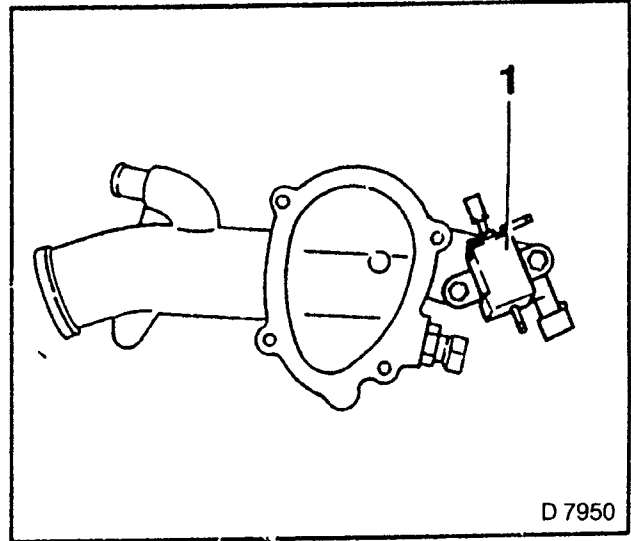


Fig. 638

6. Connection diagram of hot start valve.

### INSTALL, CONNECT

1. Hot start valve (1) to throttle valve manifold.
2. Vacuum hoses.
3. Wiring plug.
4. Throttle valve manifold cover — tightening torque 5 Nm.

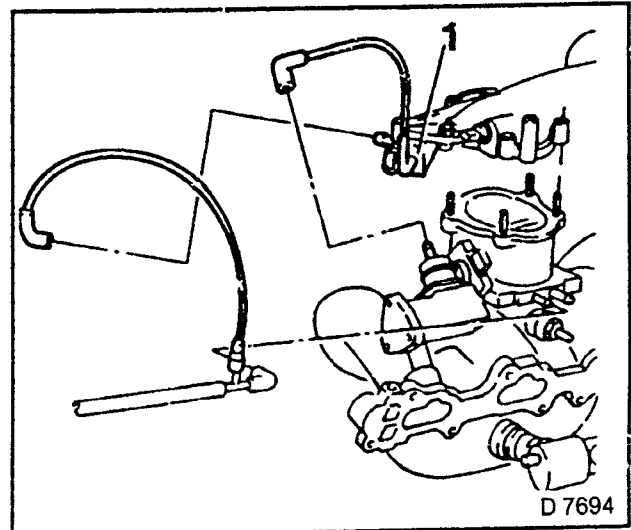


Fig. 639

## Hot-wire Mass Air Flow Meter — Remove and Install

### REMOVE, DISCONNECT

1. Wiring plug (1) and
2. Intake hose (3) from hot-wire mass air flow meter.

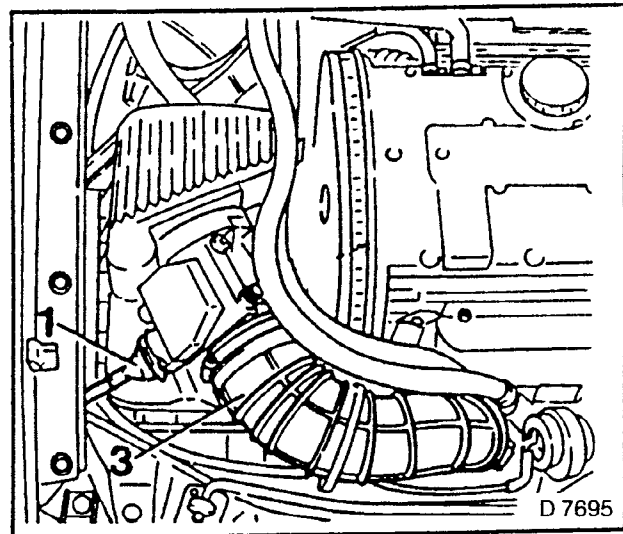


Fig. 640



**REMOVE, DISCONNECT**

1. Upper part of air cleaner with hot-wire mass air flow meter.
2. Hot-wire mass air flow meter (1) from upper part of air cleaner.
3. Note seal ring in upper part of air cleaner.

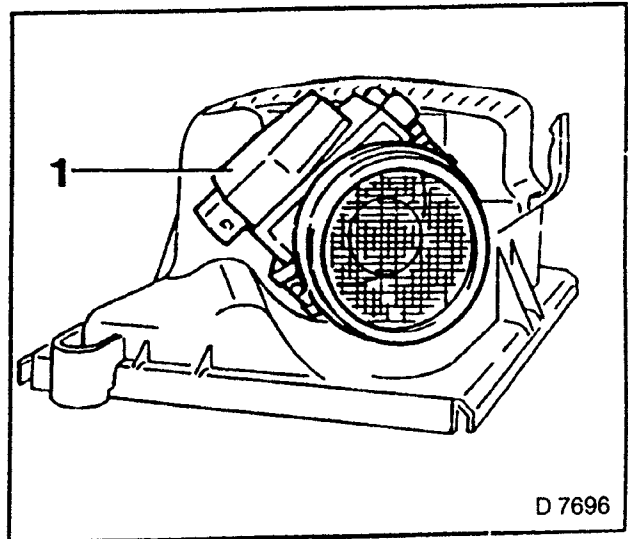


Fig. 641

**INSTALL, CONNECT**

1. Hot-wire mass air flow meter with new seal ring in upper part of air cleaner.
2. Upper part of air cleaner with hot-wire mass air flow meter.

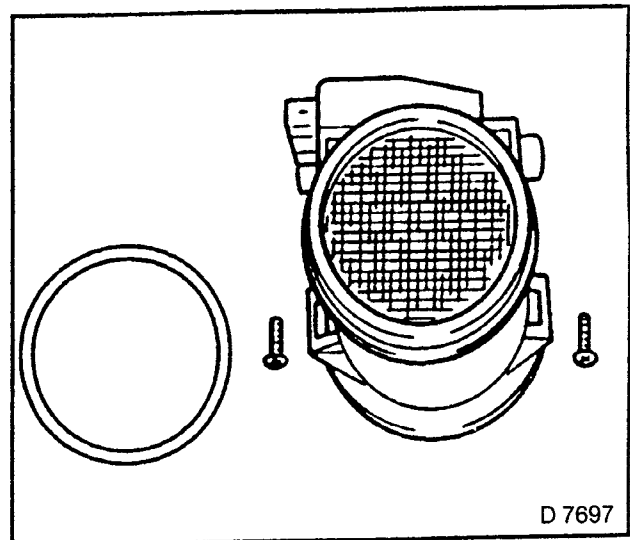


Fig. 642

**INSTALL, CONNECT**

1. Wiring plug (1) and,
2. Intake hose (3), to hot-wire mass air flow meter.
3. Ensure that intake hose is correctly seated.

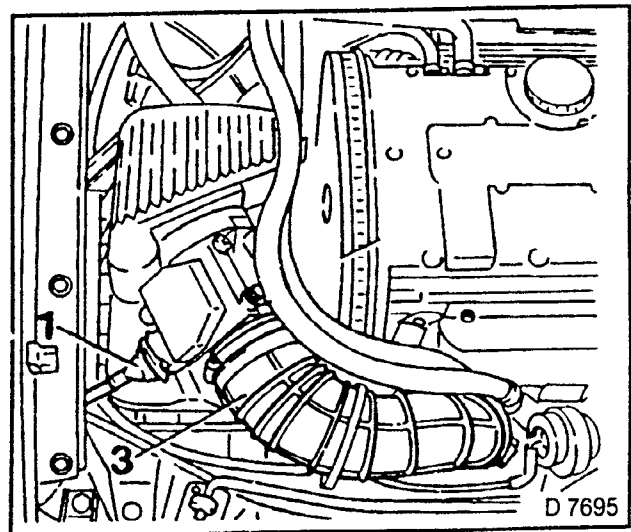


Fig. 643

## Inductive Pulse Pick-up — Remove and Install

### REMOVE, DISCONNECT

1. Disconnect wiring plug (1) — note routing of cables.

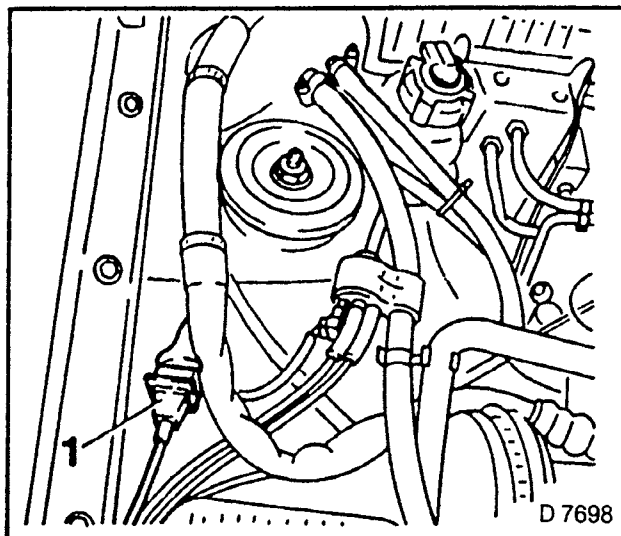


Fig. 644

### REMOVE, DISCONNECT

1. Intake hose (1) between hot-wire mass air flow meter and turbocharger.

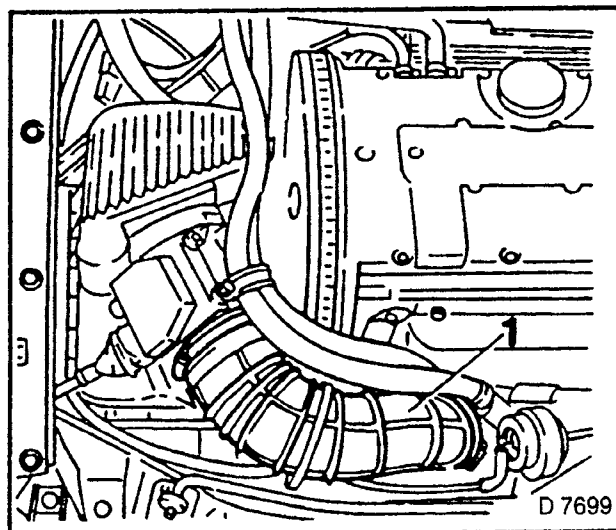


Fig 645

### REMOVE, DISCONNECT

- 1 Inductive pulse pick-up with seal ring.

### INSTALL, CONNECT

1. Inductive pulse pick-up with new seal ring — tightening torque 6 Nm.
2. Intake hose between hot-wire mass air flow meter and turbocharger.
3. Connect wiring plug.
4. Ensure that intake hose is correctly seated.

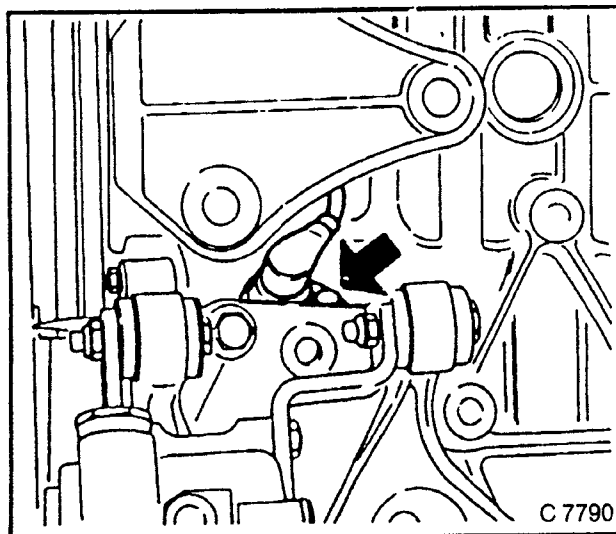


Fig 646

## Fuel Pressure Regulator — Remove and Install

### REMOVE, DISCONNECT

1. Throttle valve manifold cover.
2. Vacuum hose.
3. Fuel pressure regulator (1) from fuel distributor pipe.

**WARNING:**  
**FUEL ESCAPES**  
**OBSERVE SAFETY MEASURES AND NATIONAL REGULATIONS.**

### INSTALL, CONNECT

1. Fuel pressure regulator to fuel distributor pipe.
2. Vacuum hose to fuel pressure regulator.
3. Throttle valve manifold cover.

### TIGHTEN (TORQUE)

1. Fuel pressure regulator to fuel distributor pipe — 4 Nm.
2. Throttle valve manifold cover to throttle valve manifold — 5 Nm.

## Fuel Pressure — Check

### REMOVE, DISCONNECT

1. Throttle valve manifold cover.
2. Slowly open screw cap (1) — pressure decreases.
3. Fuel pressure gauge KM-J-34730-1 or KM-J-34730-91 to checking connection
4. Bleed fuel pressure gauge.
5. Start engine — idle speed.

### MEASURE

1. Fuel pressure.
2. Vacuum hose for fuel pressure regulator.  
 Connected: 2,2 — 2,7 bar.  
 Removed: 3,0 — 3,5 bar.

### INSTALL, CONNECT

1. Throttle valve manifold cover — tightening torque 5 Nm.

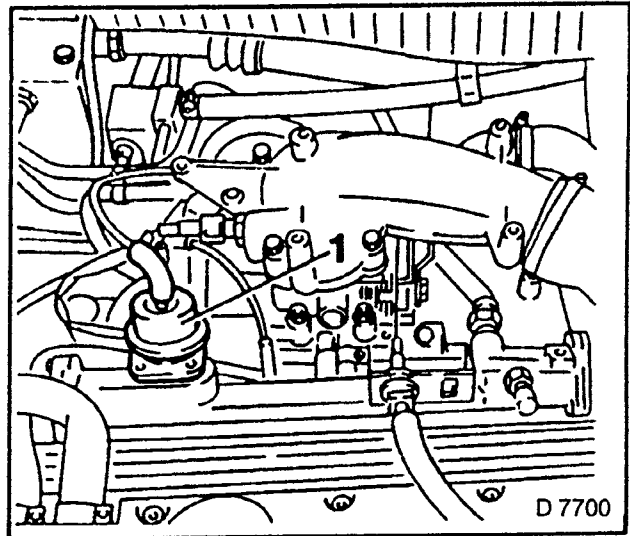


Fig. 647

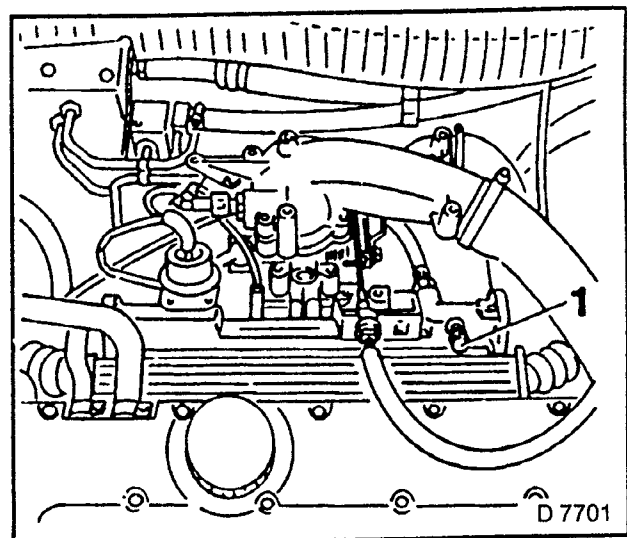


Fig. 648

## Fuel Pump Relay — Remove and Install

### REMOVE, DISCONNECT

1. Ground cable from battery.
2. Front right footwell cover.
3. Fuel pump relay (1) from socket.

### INSTALL, CONNECT

1. Fuel pump relay (1) in socket.
2. Front right footwell cover.
3. Ground cable to battery.

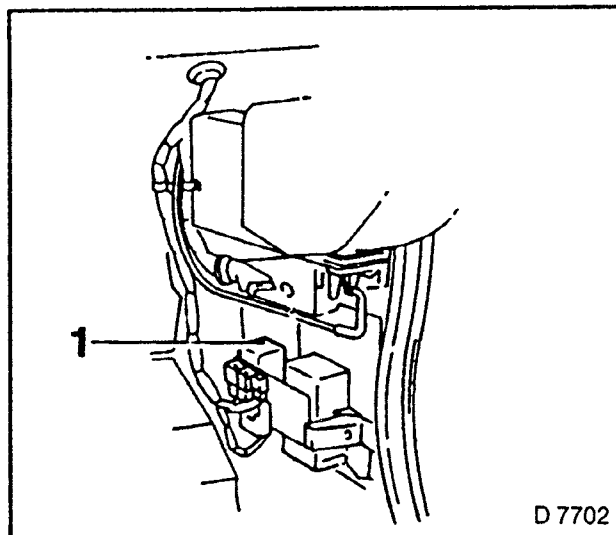


Fig. 649

## Idle Speed Adjuster — Remove and Install

For clearer representation, Fig. 583 shows the idle speed adjuster with the engine removed.

### REMOVE, DISCONNECT

1. Ground cable from battery.
2. Alternator.
3. Throttle valve manifold cover
4. Hose (1) from throttle valve manifold and hose (2) from intake manifold.
5. Wiring plug from idle speed adjuster.
6. Idle speed adjuster — note routing of hoses.

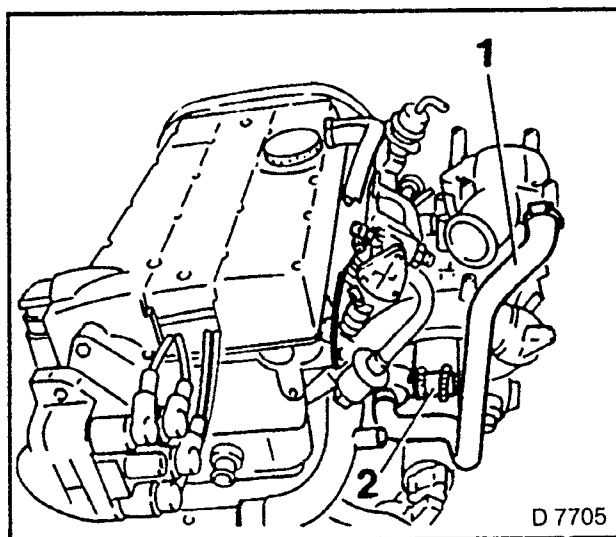


Fig. 650

### INSTALL, CONNECT

1. Idle speed adjuster.
2. Hoses to intake manifold and to throttle valve manifold.
3. Wiring plug for idle speed adjuster.
4. Alternator.
5. Throttle valve manifold cover — tightening torque 5 Nm.
6. Ground cable to battery.

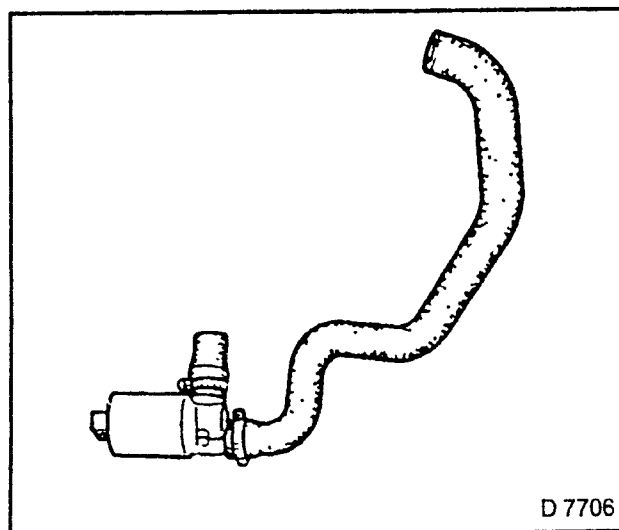


Fig. 651

## Control Unit — Remove and Install

### REMOVE, DISCONNECT

1. Ground cable from battery.
2. Front right footwell cover.
3. Relay bracket.
4. Wiring plug for control unit.
5. Control unit.
6. Pressure vacuum hose (1) from control unit.

### INSTALL, CONNECT

1. Pressure/vacuum hose to control unit.
2. Control unit.
3. Wiring plug for control unit.
4. Relay bracket.
5. Front right footwell cover.
6. Cover below glove compartment.
7. Ground cable to battery.

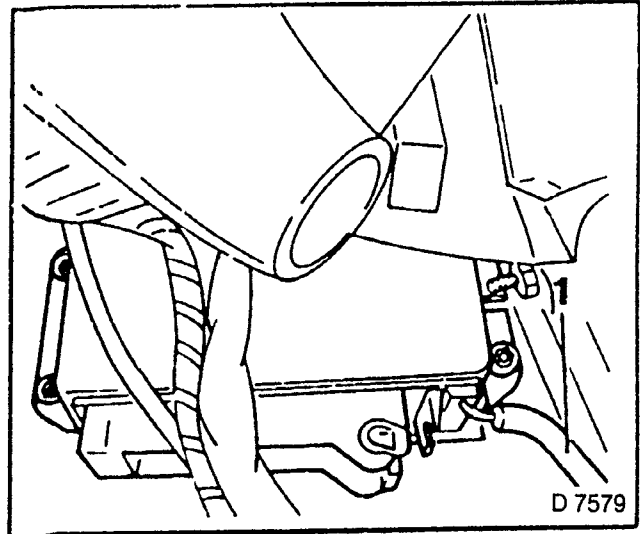


Fig. 652

## Tank Vent Valve — Remove and Install

### REMOVE, DISCONNECT

1. Wiring plug for tank vent valve.
2. Hoses (1) and (2) — close off hose (2) (spring clamps).
3. Tank vent valve.  
Hose 1 = connection to throttle body  
Hose 2 = connection to active carbon canister.

### INSTALL, CONNECT

1. Tank vent valve.
2. Hoses — remove spring clamps.
3. Wiring plug for tank vent valve.

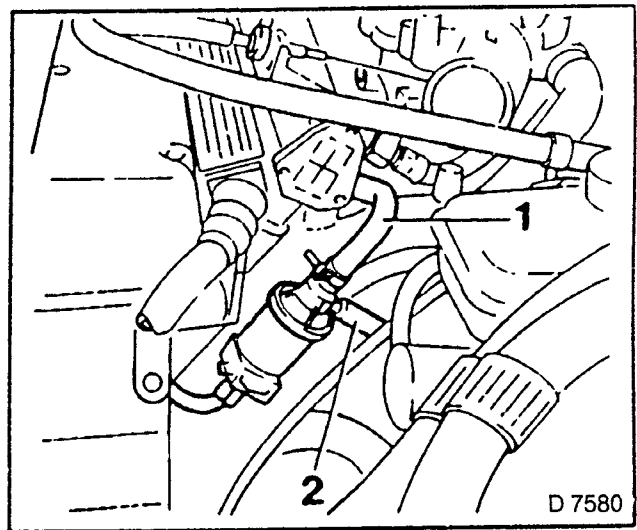


Fig. 653

## Intake Air Temperature Sensor — Remove and Install

### REMOVE, DISCONNECT

1. Throttle valve manifold cover.
2. Wiring plug for intake air temperature sensor.
3. Intake air temperature sensor (1) with seal ring.

### INSTALL, CONNECT

1. Intake air temperature sensor (1) with new seal ring — Tightening torque 10 Nm.
2. Wiring plug for intake air temperature sensor.
3. Throttle valve manifold cover — tightening torque 5 Nm.

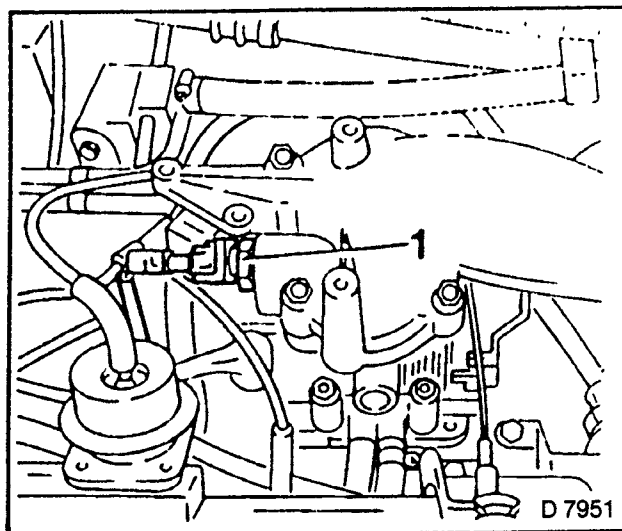


Fig. 654

## Coolant Temperature Sensor — Remove and Install

### REMOVE, DISCONNECT

1. Intake hose (1) between hot-wire mass air flow meter and turbocharger.

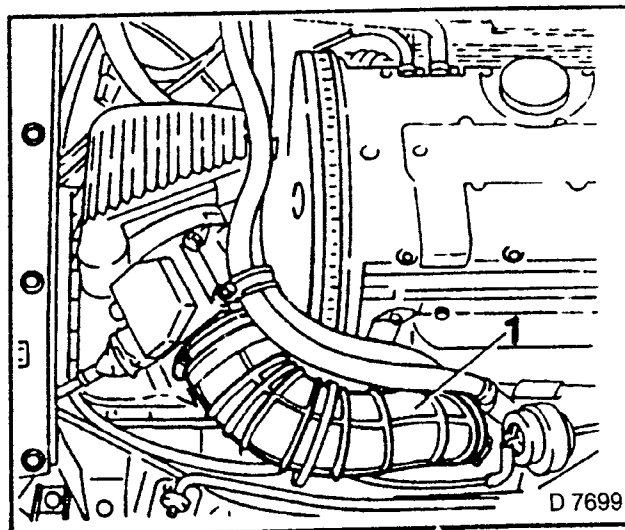


Fig 655

### REMOVE, DISCONNECT

1. Wiring plug for coolant temperature sensor.
2. Coolant temperature sensor (1).
3. Coolant escapes — collect coolant.

### INSTALL, CONNECT

1. Coolant temperature sensor with new seal ring — tightening torque 11 Nm.
2. Wiring plug (1) for coolant temperature sensor.
3. Intake hose between hot-wire mass air flow meter and turbocharger — ensure correct seating.
4. Top up and bleed cooling system.

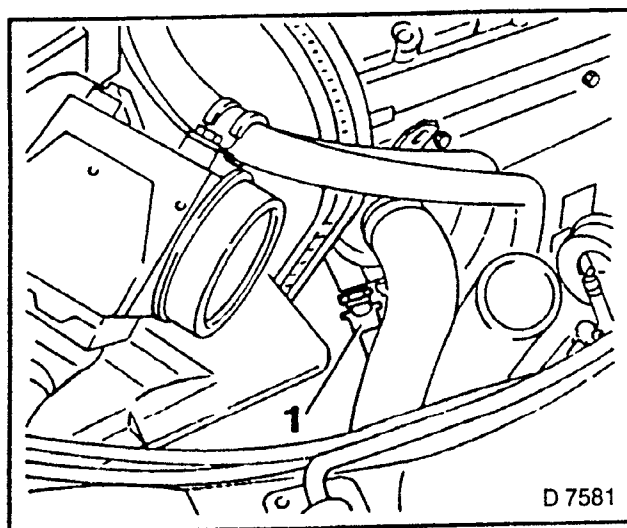


Fig. 656

## Bypass Valve — Charge Pressure Control — Remove and Install

### REMOVE, DISCONNECT

1. Wiring plug for bypass valve for charge pressure control.
2. Pressure/vacuum hoses — mark installation positions.
3. Bypass valve for charge pressure control from rubber bearing (1).

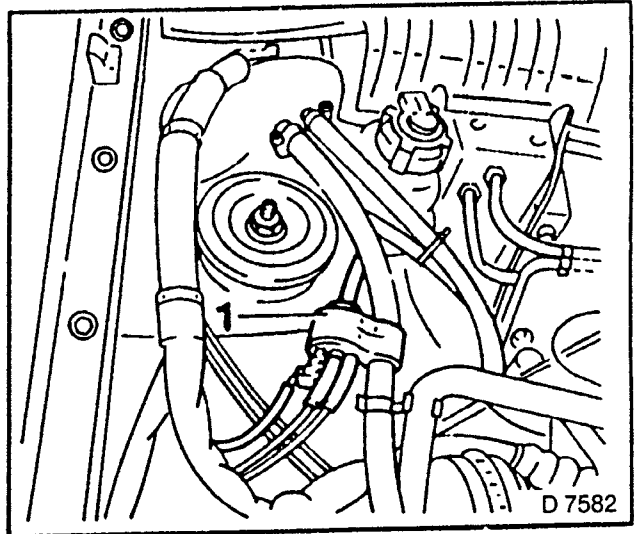


Fig. 657

### INSTALL, CONNECT

1. Bypass valve for charge pressure control in rubber bearing (1).
2. Pressure/vacuum hoses — note marks made previously.
3. Wiring plug for bypass valve.

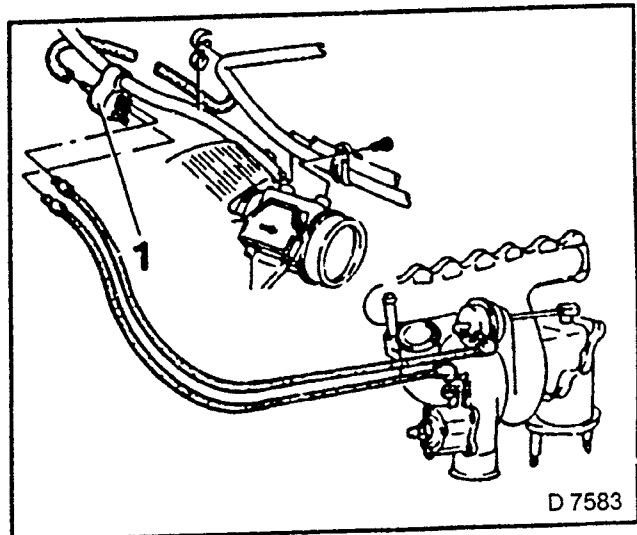


Fig. 658

## Ignition Coil — Remove and Install

Ignition switched off.

### REMOVE, DISCONNECT

1. Cable connections from ignition coil (1).
2. Wiring plug (2) from trigger box.
3. Ignition coil.

### INSTALL, CONNECT

1. Ignition coil (1).
2. Wiring plug (2) to trigger box.
3. Cable connections to ignition coil.

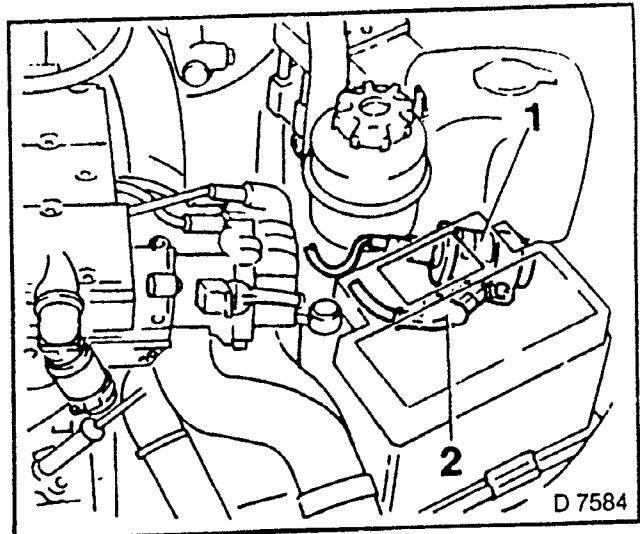


Fig. 659

## Starter — Remove and Install

### REMOVE, DISCONNECT

1. Ground cable from battery.
2. Upper starter bolt (arrow).
3. Engine compartment cover.
4. Intake pipe-cylinder block support, brake servo.
5. Vacuum hose from intake pipe (if necessary).
6. Cable connection from starter.
7. Starter support from cylinder block, lower starter bolt.

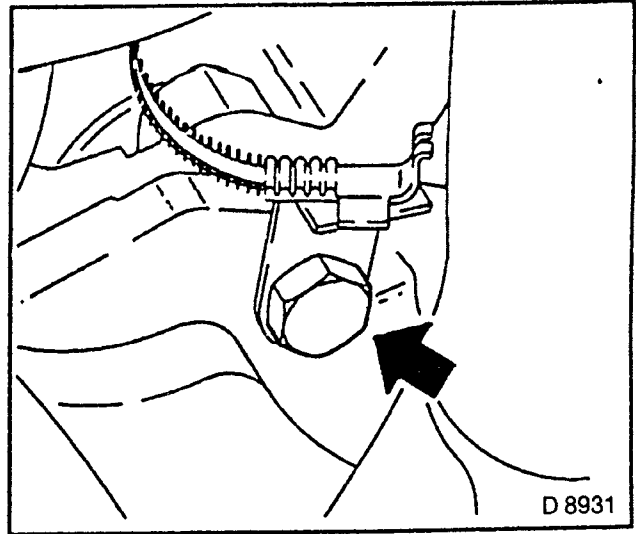


Fig. 660

### TIGHTEN (TORQUE)

1. Starter to cylinder block (A) — 45 Nm.
2. Starter to cylinder block (transmission side) — 75 Nm.
3. Starter support to cylinder block (B) — 25 Nm.
4. Brake servo vacuum hose to intake pipe — 15 Nm.
5. Support to intake pipe and cylinder block — 25 Nm.
6. Connect cables.
7. Connect battery.
8. Ensure perfect condition and seating.
9. Install engine compartment cover.

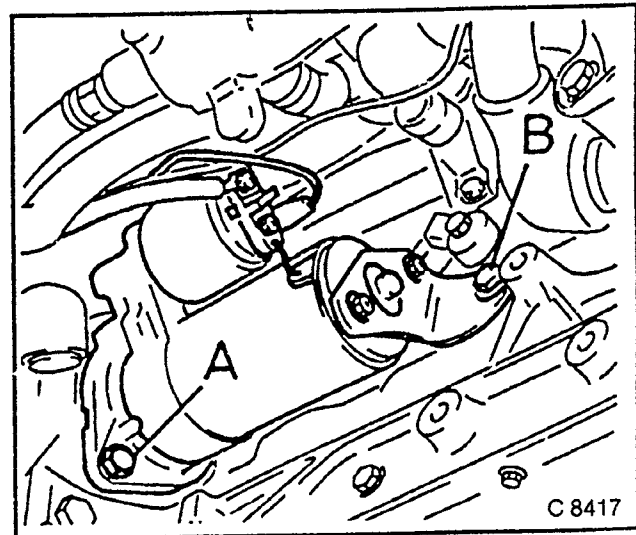


Fig 661

## Alternator — Remove and Install

### REMOVE, DISCONNECT

1. Ground cable from battery.
2. Air intake hose.
3. Throttle valve manifold cover
4. Upper alternator fastening from clamping bracket.
5. Remove V-belt.
6. Cable connections from alternator
7. Alternator from lower fastening.

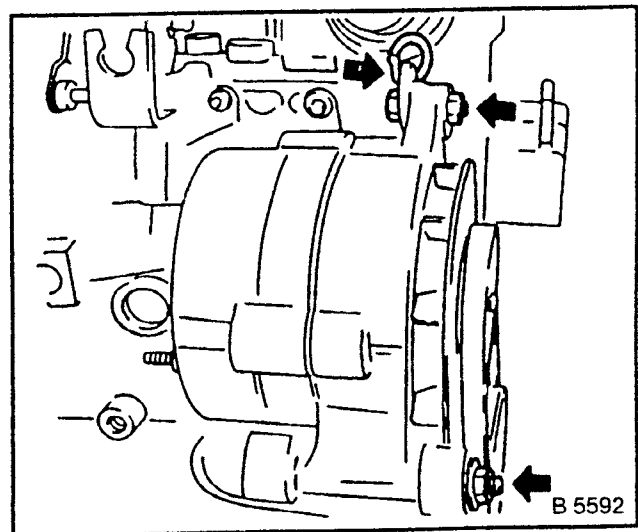


Fig 662



**INSTALL, CONNECT**

1. Alternator to bracket — 25 Nm.
2. Cable connections to alternator.
3. Ensure perfect condition and seating.
4. Install V-belt and tension.
5. Air intake hose.
6. Connect battery.

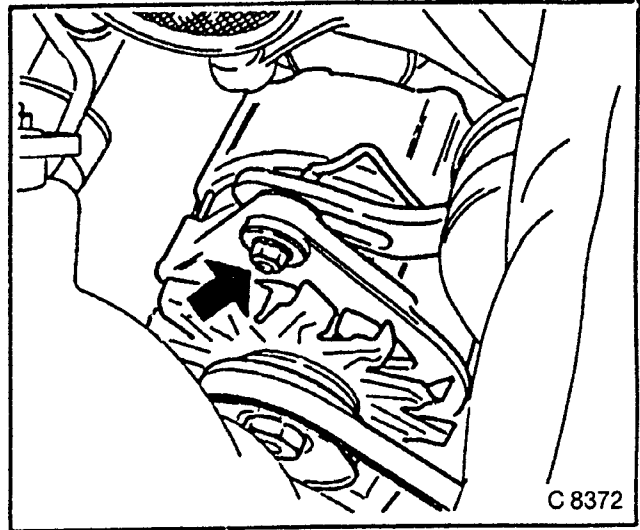
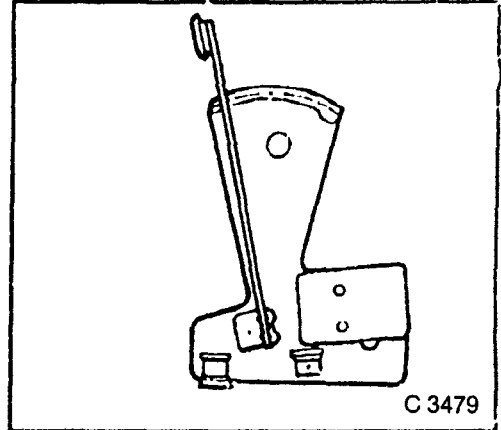


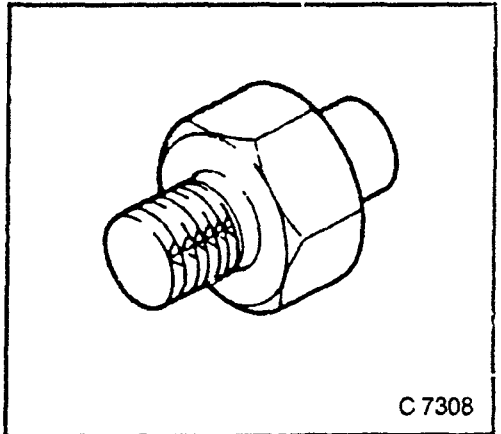
Fig. 663

**SPECIAL SERVICE TOOLS****KM-128-A TENSION GAUGE**

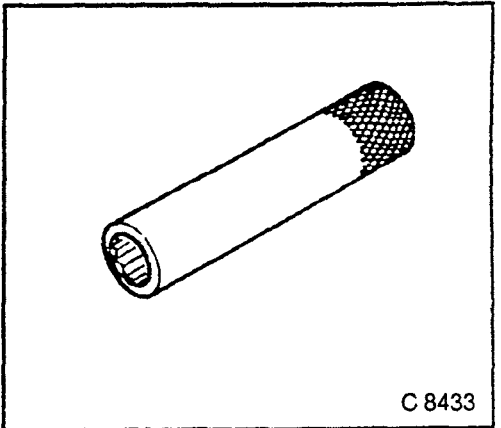
To check the V-belt tension.

**KM-135 ADAPTER**

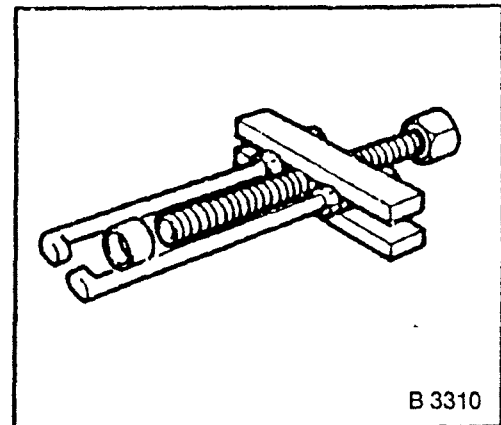
To measure engine oil pressure in conjunction with KM-498-B.

**KM-194 SPARK PLUG WRENCH**

To remove and install spark plugs with size 16 mm.

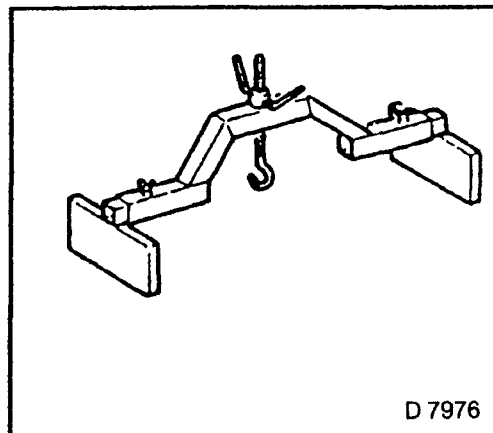
**KM-210-A WHEEL PULLER**

To remove toothed belt drive pinion in conjunction with KM-516 and KM-647.

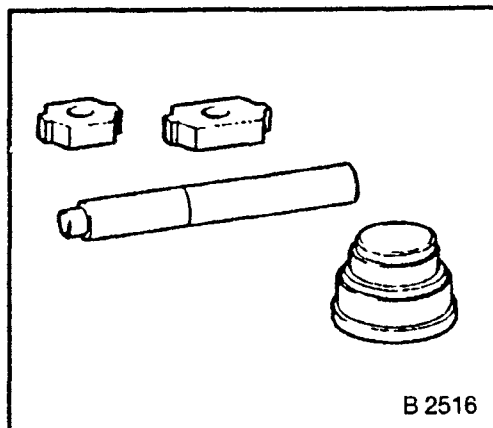


**KM-263-B ENGINE LIFTER/HOLDER**

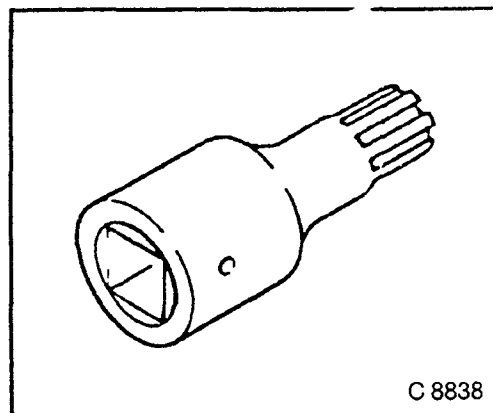
Attach engine to lifter without cable to bracket with commercially available spring hook.

**KM-266-A REMOVER/INSTALLER**

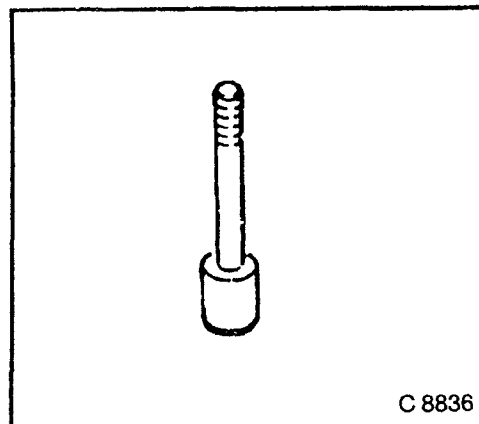
To install starter bearing bushings/install TDC sensor sleeve.

**KM-321-A SPLINED WRENCH**

To remove/install crankshaft pulley.

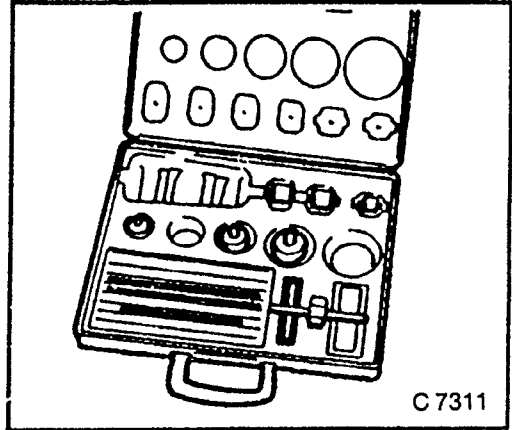
**KM-328-8 PIN**

To remove the rear crankshaft seal ring in conjunction with KM-469-4, KM-469-13-A and KM-665 (transmission installed).

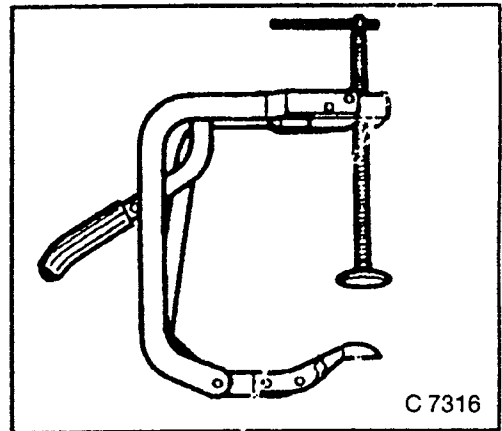


**KM-340-C VALVE CUTTER SET**

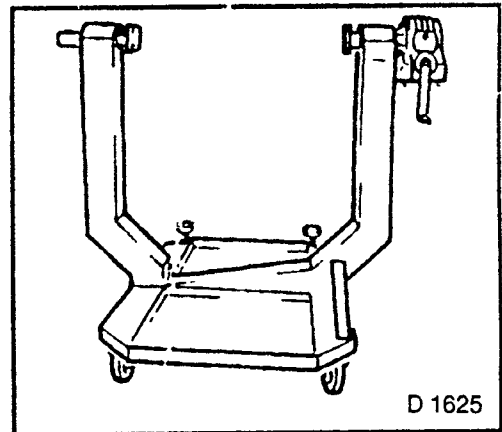
To cut, correct valve seat.

**KM-348 SPRING COMPRESSOR**

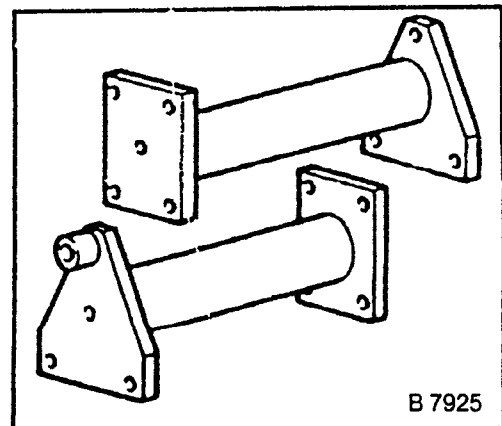
To compress valve spring in conjunction with KM-653.

**KM-412 ENGINE OVERHAUL STAND**

To hold removed engine.

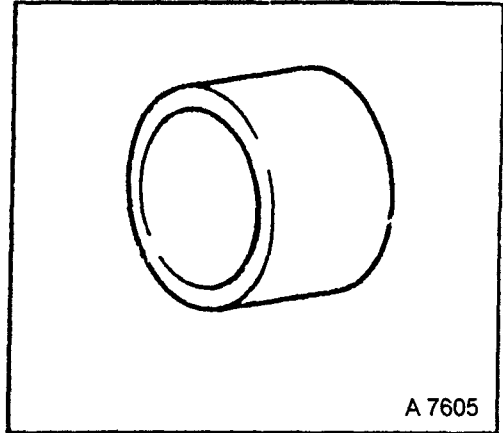
**KM-412-8 ADAPTER**

To hold removed engine in conjunction with KM-412.

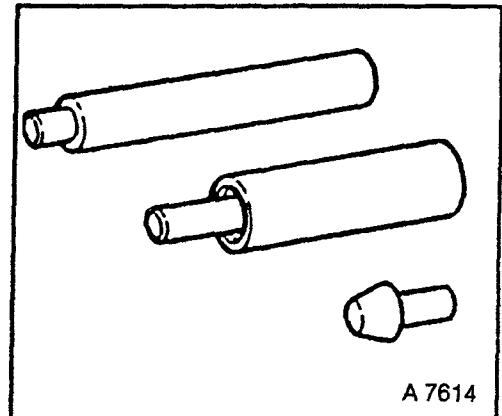


**KM-422 REMOVER/INSTALLER**

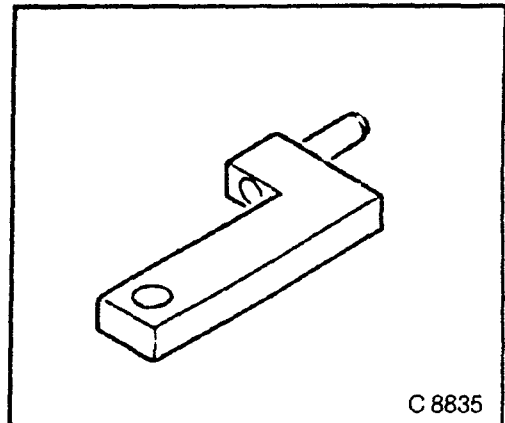
To install seal ring into camshaft carrier.

**KM-427 REMOVER/INSTALLER**

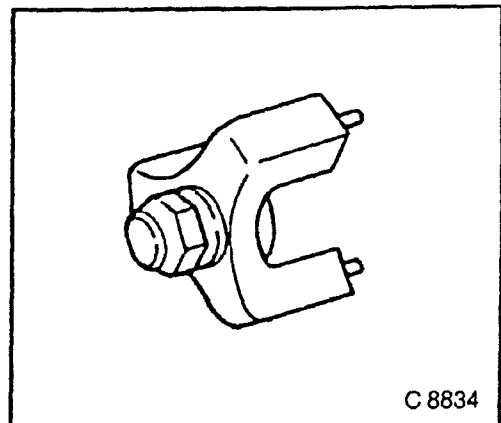
To install centring pin in engine block.

**KM-469-4 SUPPORT**

To remove rear crankshaft seal ring in conjunction with KM-328-8, KM-469-13-A and KM-665 (transmission installed).

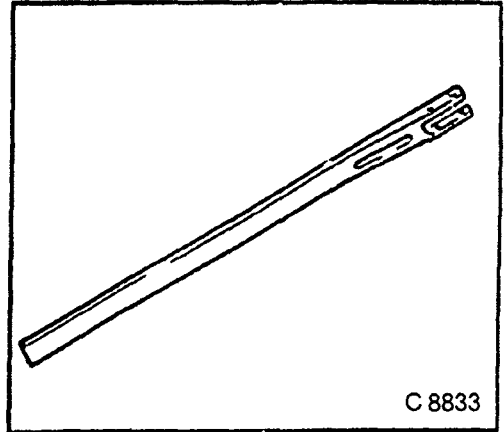
**KM-469-12-B HEX BOLT**

To install rear crankshaft seal ring in conjunction with KM-511-11, KM-635-1 and KM-635-2 (transmission installed).

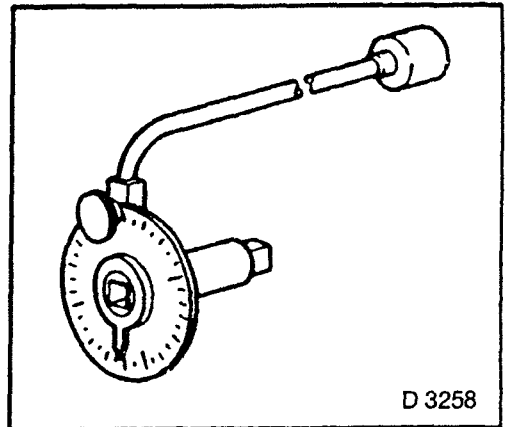


**KM-469-13-A LEVER**

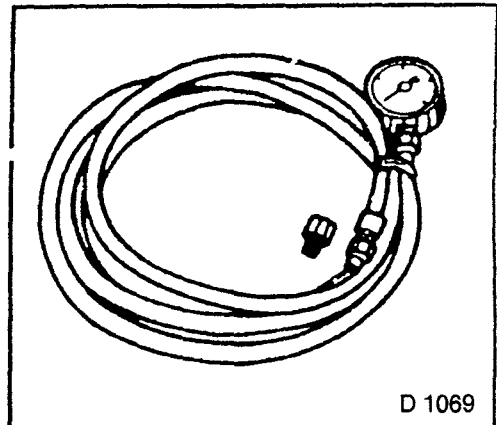
To remove rear crankshaft seal ring in conjunction with KM-328-8, KM-469-4 and KM-665 (transmission installed).

**KM-470-B ANGULAR TORQUE WRENCH**

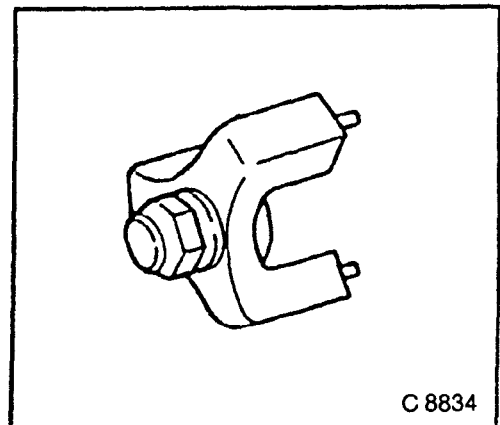
To tighten cylinder head bolts.

**KM-498-B PRESSURE GAUGE**

To check oil pressure in conjunction with KM-135.

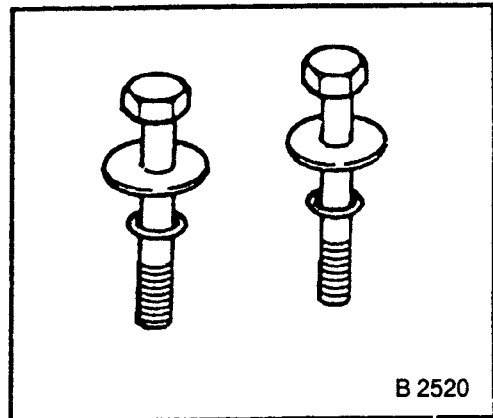
**KM-511-11 HOLDING PLATE**

To install crankshaft seal ring in conjunction with KM-469-12-B, KM-635-1 and KM-635-2 (transmission installed).



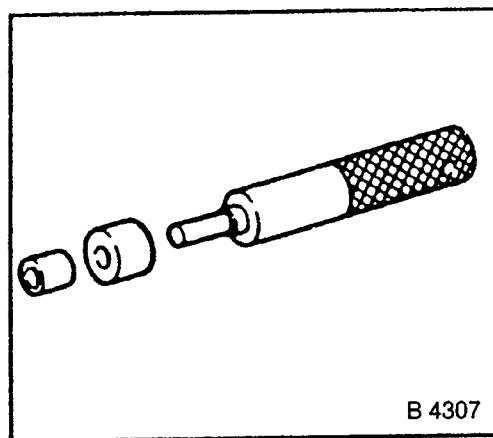
**KM-516 PULLER SCREWS**

To remove toothed belt drive gear in conjunction with KM-210-A and KM-647.



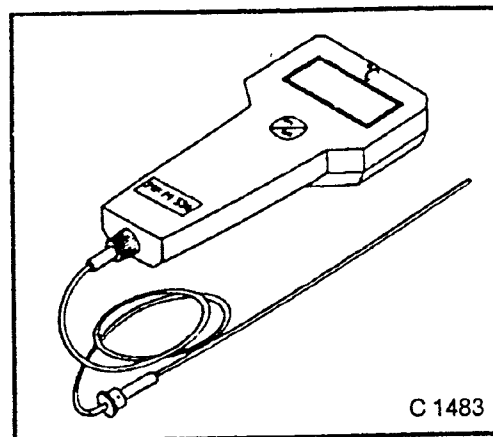
**KM-535 INSTALLER**

To install rear crankshaft seal ring in conjunction with KM-635-1 and KM-635-2 (transmission removed).



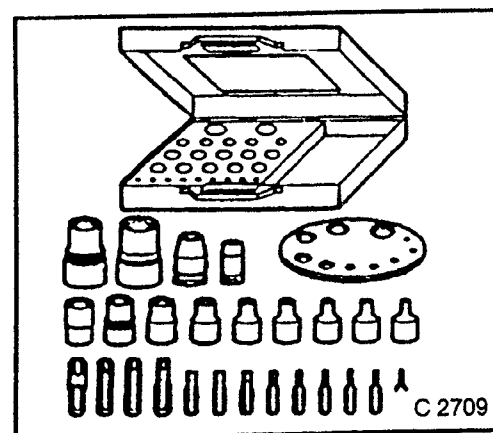
**MKM-596 GAUGE**

To measure oil temperature (special exhaust gas test — "ASU").



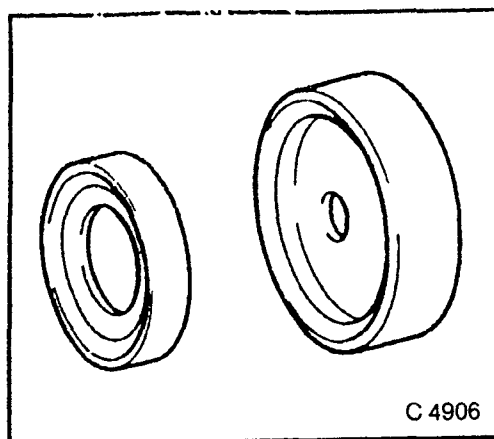
**MKM-604-B TORX BIT AND SOCKET SET**

To remove/install Torx bolts.

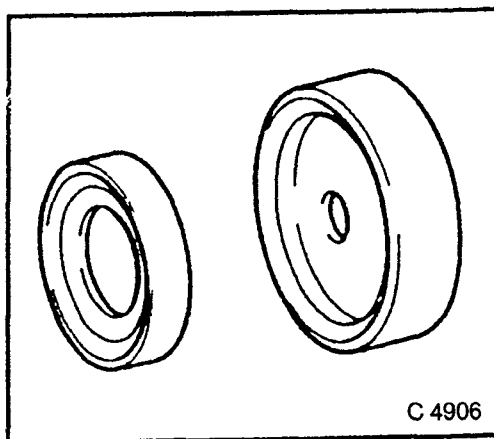


**KM-635-1 PROTECTIVE SLEEVE**

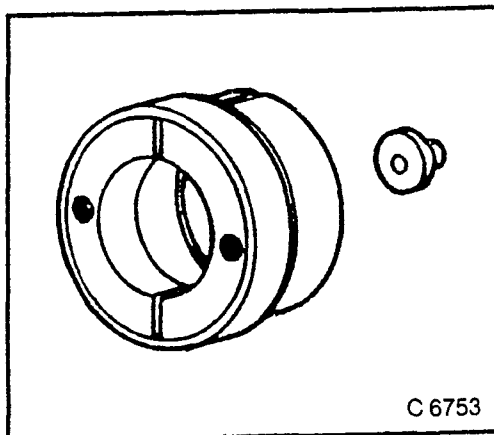
To install rear crankshaft seal ring in conjunction with KM-469-12-B, KM-511-11 and KM-635-2 (transmission installed) or KM-535 (transmission removed).

**KM-635-2 THRUST RING**

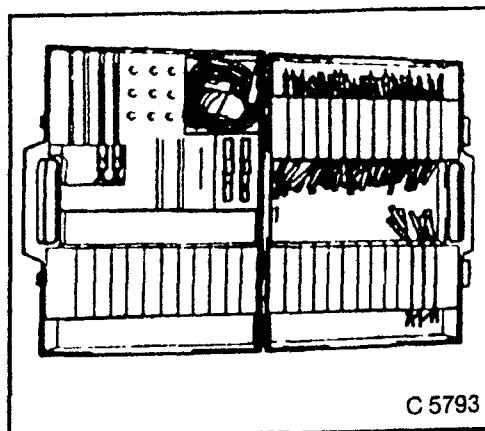
To install rear crankshaft seal ring in conjunction with KM-469-12-B, KM-511-11 and KM-635-2 (transmission installed) or KM-535 (transmission removed).

**KM-647 REMOVER**

To remove toothed belt drive gear in conjunction with KM-210-A and KM-516.

**KM-609 ELECTRONIC KIT I**

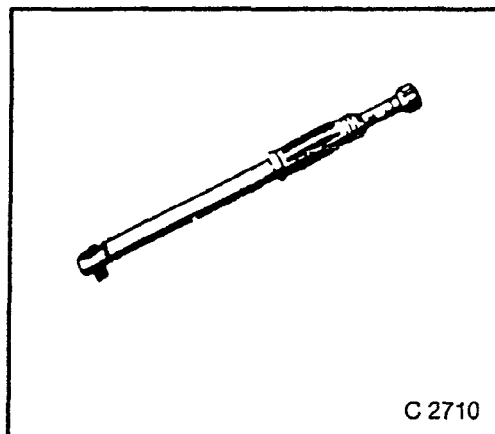
Diagnosis of electric and electronic systems.





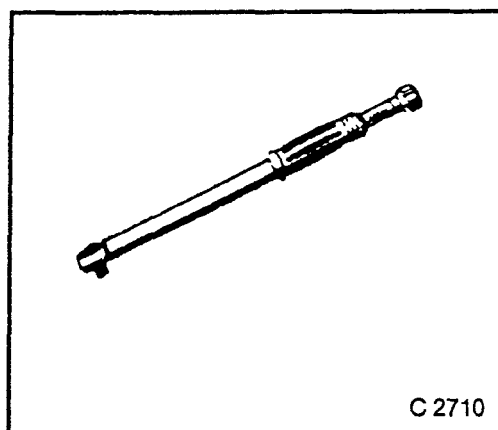
**MKM-610 TORQUE WRENCH 1/2"  
DRIVE**

Measuring range 30 — 130 Nm.



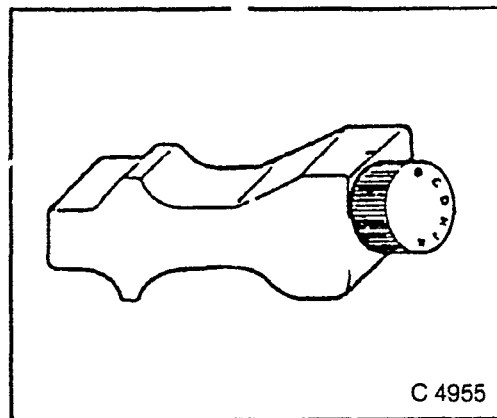
**MKM-611 TORQUE WRENCH 3/8"  
DRIVE**

Measuring range 10 — 60 Nm.



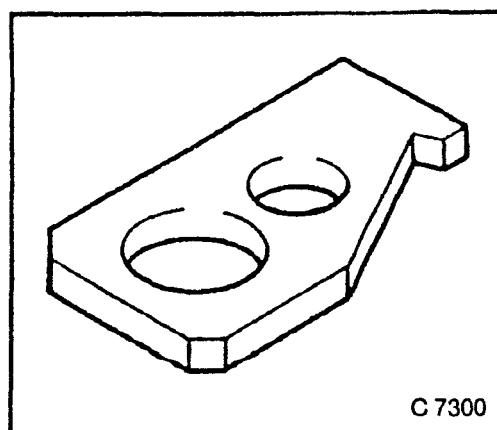
**KM-640 DIAGNOSTIC SWITCH**

To trigger blink code output, engines with self-diagnosis.



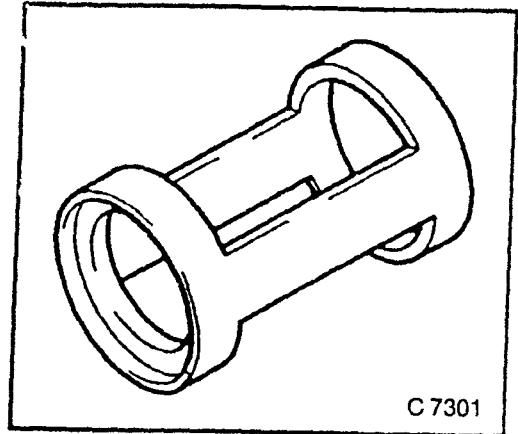
**KM-652 FLYWHEEL LOCKING DEVICE**

To lock the flywheel.

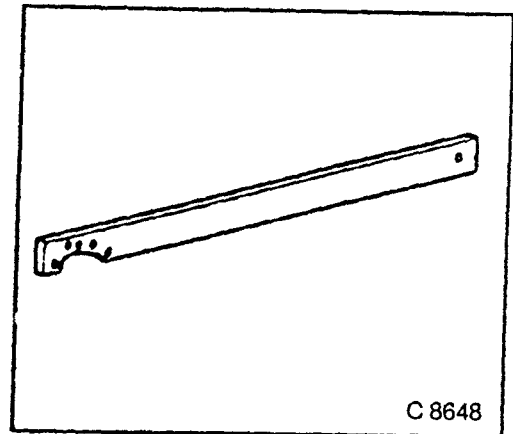


**KM-653 ADAPTER**

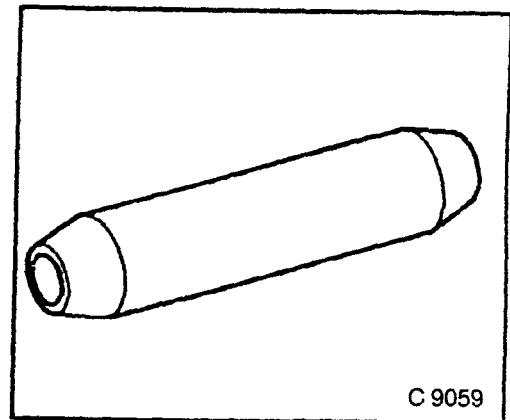
To tension valve spring in conjunction with KM-348.

**KM-662-A HOLDING WRENCH**

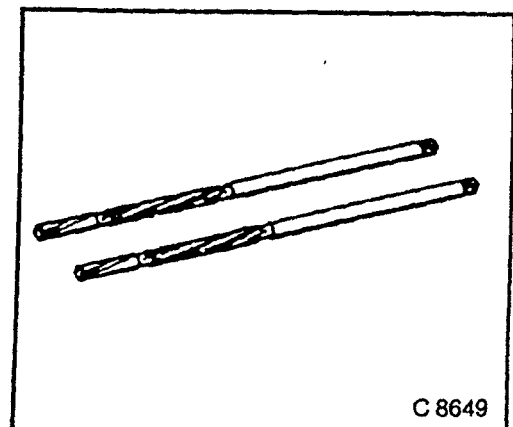
To hold the toothed belt drive pinion when removing or installing fastening bolt.

**KM-663 INSTALLER**

To install valve stem seal.

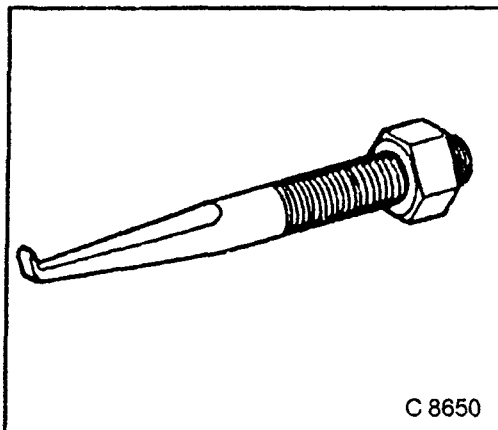
**KM-664 REAMER SET**

To ream valve guide.

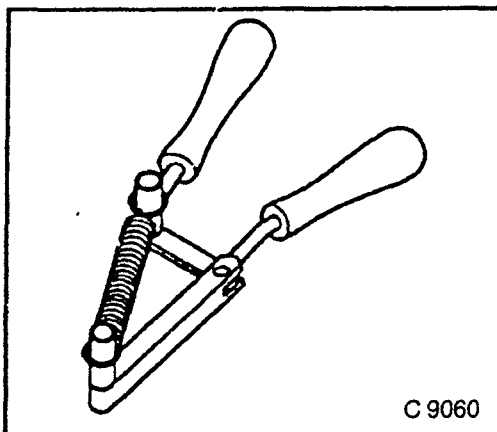


**KM-665 REMOVER HOOK**

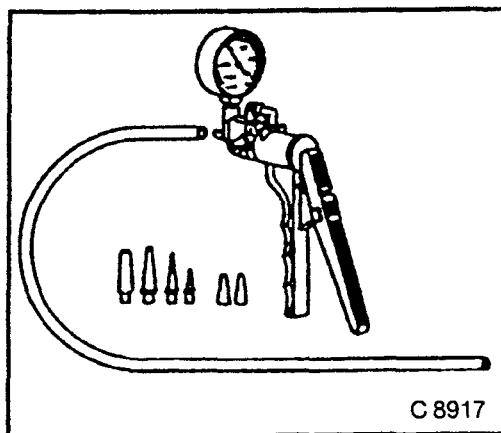
To remove rear crankshaft seal ring in conjunction with KM-328-8, KM-469-4 and KM-469-13-A (transmission installed)

**KM-666 ADJUSTER**

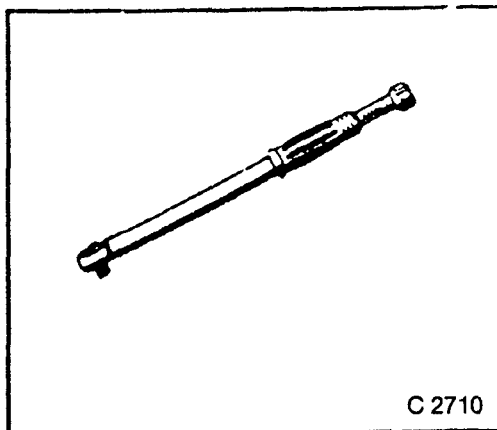
To adjust toothed belt tension.

**MKM-667 PRESSURE AND VACUUM PUMP**

To check for leaks on vacuum unit.

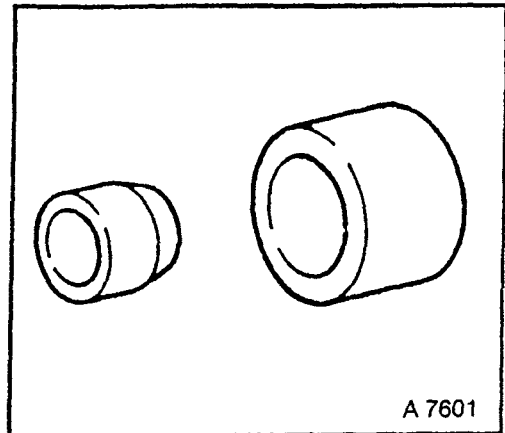
**MKM-669 TORQUE WRENCH**

Measuring range 50 — 300 Nm.

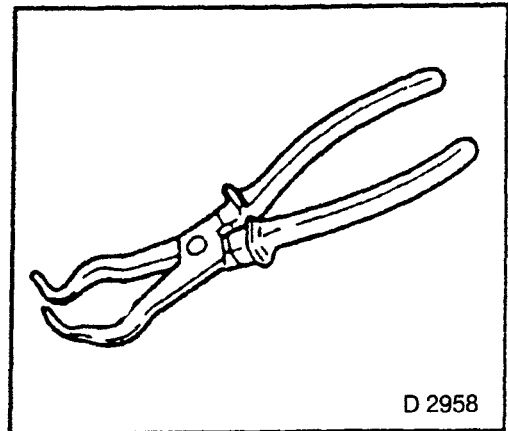


**KM-693 ASSEMBLY SLEEVES**

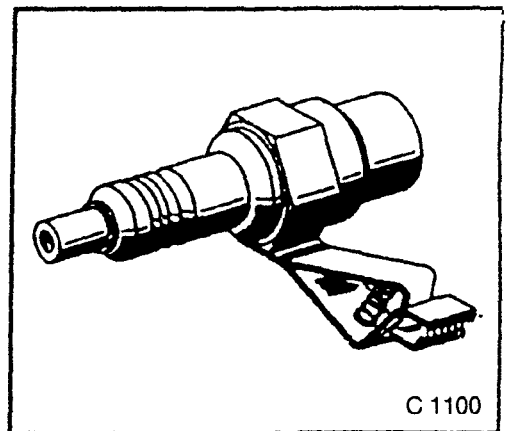
To install crankshaft front seal ring (in oil pump housing).

**KM-717 REMOVING PLIERS**

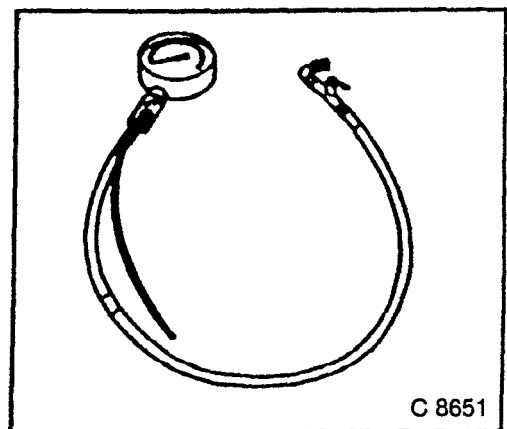
To remove spark plug connectors.

**KM-J-26792 SPARK TESTER**

To check ignition spark.

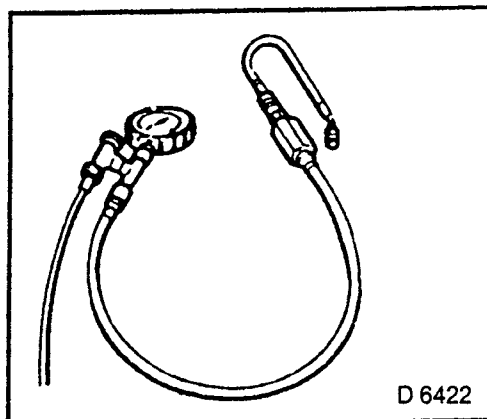
**KM-J-34730-1 PRESSURE GAUGE**

To check fuel pressure.



**KM-J-34730-91 PRESSURE GAUGE**

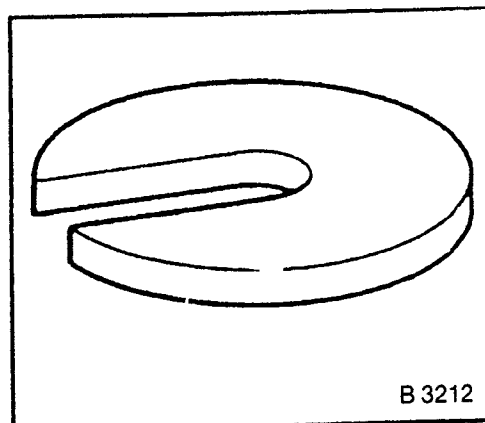
To check fuel pressure.



**COOLING SYSTEM**

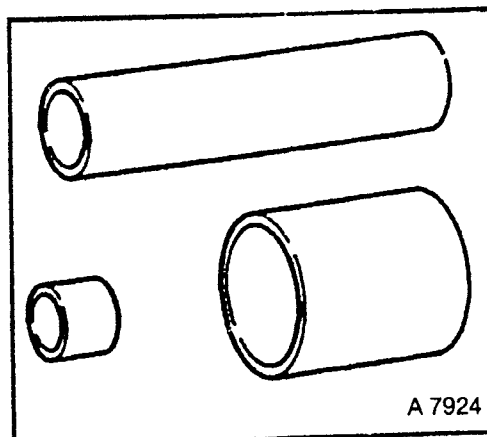
**KM-251-01 REMOVER PLATE**

To remove water pump drive and impeller.



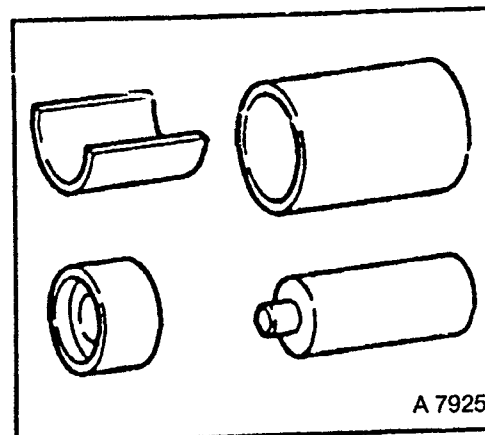
**KM-258 INSTALLER SLEEVE**

To disassemble and assemble water pump.



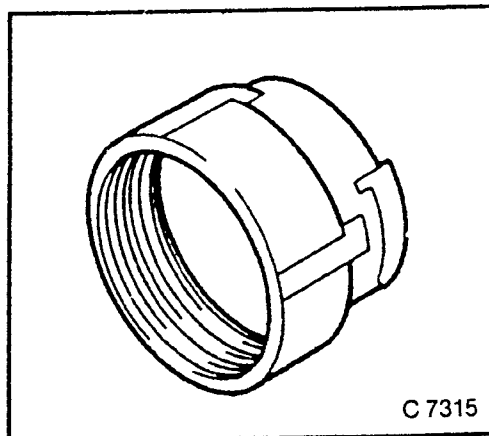
**KM-265 INSTALLER**

To assemble water pump.

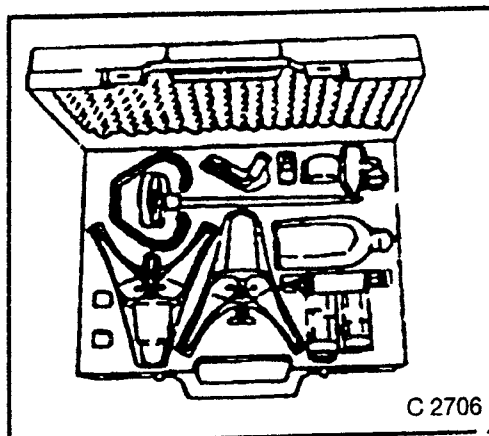


**KM-471 ADAPTER**

To check the cooling system under pressure in conjunction with MKM-601.

**MKM-601 TESTER (NO LONGER AVAILABLE)**

Diagnosis of cooling system in conjunction with KM-471.



## Technical Data

| COOLING | 14 NV | C 16 NZ | C 16 SE | 18 SE | 20 SEH | 20 XE | 20 LET |
|---------|-------|---------|---------|-------|--------|-------|--------|
|---------|-------|---------|---------|-------|--------|-------|--------|

### RADIATOR

| Design:                               | Cross-flow |      |      |      |   |      |      |
|---------------------------------------|------------|------|------|------|---|------|------|
| Radiator core surface cm <sup>2</sup> | 1690       | 1690 | 1690 | 1930 | — | 1930 | 2000 |

### COOLANT FILLING QUANTITY

#### ANTI-FREEZE MIXTURE

| (SABS 1251)             | 6l        | 6l        | 6l        | 7,5l    | 7,5l    | 7,5l    | 7l      |
|-------------------------|-----------|-----------|-----------|---------|---------|---------|---------|
| (Ratio water to Glycol) | 3,36:2,64 | 3,36:2,64 | 3,36:2,64 | 4,2:3,3 | 4,2:3,3 | 4,2:3,3 | 3,9:3,1 |

Capacity of cooling system with heating (in litres)

When topping-up use Anti-freeze SABS 1251

C 20 XE, C 20 LET

#### Fan

|                    |                |
|--------------------|----------------|
| Design             | electric drive |
| Number of blades   | 5              |
| Distribution in mm | assymetric     |
| Diameter in mm     | 366            |

#### Thermoswitch

|                 |       |
|-----------------|-------|
| Switches on at  | 100°C |
| Switches off at | 95°C  |

#### Screw-type lid

|                               |                           |
|-------------------------------|---------------------------|
| Boiling point                 | 125°C                     |
| Opening pressure in kPa (bar) | 120 to 135 (1,20 to 1,35) |

#### Thermostat

|                  |        |
|------------------|--------|
| Start of opening | 91°C   |
| Fully open       | 107°C  |
| Type             | Bypass |

### TOOTHED BELT TENSION

Applies to engines without toothed belt tension roller:

|                   |                   |
|-------------------|-------------------|
| Adjusting values* | C 18 SE, C 20 SEH |
|-------------------|-------------------|

#### New toothed belt

|      |     |
|------|-----|
| Cold | 4,5 |
| Warm | 7,5 |

#### Used toothed belt

|      |     |
|------|-----|
| Cold | 2,5 |
| Warm | 7,0 |

\*Correspond to indication on KM-510-A

Note: 1,4 and 1,6 ltr. engines equipped with automatic toothed belt tension roller  
— retensioning not required

### TURBOCHARGING SYSTEM

|       |   |
|-------|---|
| Type: | Exhaust Turbocharger (KKK16) with charge cooler |
|-------|---|

**OIL CIRCUIT****ENGINE OIL VISCOSITY**

The following engine oils can be used:

- A = single grade oils
- B = multi-grade oils
- C = easy run oils

depending on the outside temperature, for both petrol and diesel engines:

**ENGINE OIL QUALITY**

It is important that the following API and CCMC classes be used:

| Engines | Single and multi-grade oils                   | Easy run oils                          |
|---------|---|--|
| Petrol  | API - SF/CC, SF/CD, SG/CC, SG/CD<br>CCMC - G4 | API - SF/CC, SF/CD, SG/CD<br>CCMC - G5 |

Important!

CD oils designated by manufacturers specially for diesel engines are not suitable for petrol engines, unless a suitable performance class for petrol engines (e.g. API-SF/CCMC — G4) is also indicated.

**ENGINE OIL FILLING QUANTITIES**

| Engine   | Filling with filter change*<br>(litres) | Filling without filter change*<br>(litres) | MIN to MAX<br>(litres) |
|----------|---|--|------------------------|
| 14 NV    | 3,5                                     | 3,25                                       | 1,00                   |
| C 16 NZ  | 3,5                                     | 3,25                                       | 1,00                   |
| C 16 SE  | 3,5                                     | 3,25                                       | 1,00                   |
| C 20 XE  | 4,8                                     | 4,50                                       | 1,00                   |
| C 20 LET | 4,9                                     | 4,50                                       | 1,00                   |

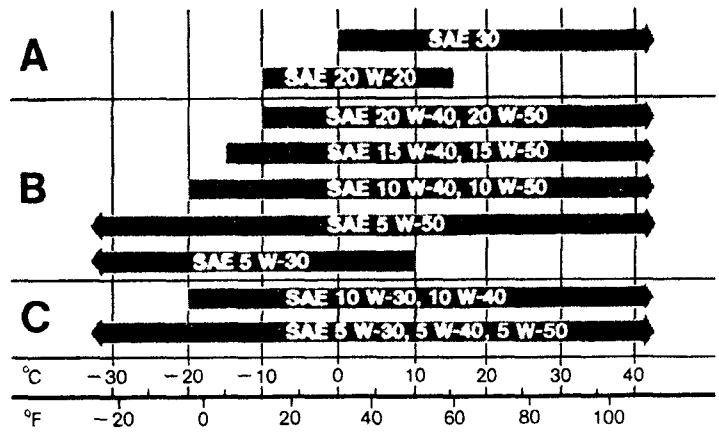
\*Up to mark "MAX" on oil dipstick

**DISPOSAL**

Relevant national regulations are to be observed when disposing of used oil.

**OIL PUMP**

|  | 14 Nv, C 16 NZ, C 16 SE | 18 SE/20 SEH      | C20 XE, C 20 LET                    |
|--|-------------------------|-------------------|-------------------------------------|
| Backlash   | 0,1 to 0,2 mm           | 0,1 to 0,2 mm     | 0,1 to 0,2 mm                       |
| Recess of gears relative to housing  | 0,8 to 0,15 mm          | 0,03 to 0,1 mm    | 0,3 to 0,1 mm                       |
| Oil pressure at idle speed and engine at operating temp (oil temperature $\geq 80^{\circ}\text{C}$ ) | 150 kPa (1,5 bar)       | 150 kPa (1,5 bar) | 250 kPa (2,5 bar)/150 kPa (1,5 bar) |
| Oil drain plug   | M 14 x 1,5              | M 14 x 1,5        | M 14 x 1,5                          |



C 9563



**ADJUSTMENT VALUES, CHECKING VALUES**

| 14 NV, C 16 NZ, C 16 SE, 18 SE, 20 SEH, 20 XE, 20 LET |   |
|---|---|
| Valve clearance                                       | Hydraulic valve lash adjustment:<br>No adjustment necessary   |
| Distributor dwell angle<br>Distributor closing time   | Electronic dwell angle control  |
| Spark plug electrode gap                              | 0,7 to 0,8 mm   |
| Compression   | The difference in compression between the individual cylinders in the engine must not exceed 100 kPa (1 bar). |
| Pressure loss test                                    | Pressure loss per cylinder with engine in perfect condition must not be more than 25%.                        |
| Timing  | Electronic Adjustment of timing, manual adjustment not possible   |

**IDLE SPEEDS, CO CONTENT, IGNITION ADJUSTMENT**

| Engine  | Idle speed in rpm |               | CO content<br>in vol. % | Ignition timing at idle speed<br>(w/o vacuum) in °CA BTDC |
|---------|-------------------|---------------|-------------------------|---|
|         | Automatic trans.  | Manual trans. |                         |   |
| 14 NV   |                   | 900 — 950     | 0,5 — 1,5               | 5   |
| C 16 SE |                   | 820 — 980     | 2,0 — 2,5               | 10  |
| C 16 NZ |                   | 780 — 940     | 2,0 — 2,5               | 10  |
| 18 SE   | 820 — 980         | 820 — 980     | 1,0 — 1,5               | 10  |
| 20 SEH  |                   | 820 — 980     | 1,0 — 1,5               | 13 — 17   |
| 20 LET  |                   | 860 — 1020    | 1,0 — 1,5               | 14 — 18   |
| 20 XELN |                   | 860 — 1020    | 1,0                     | 14 — 18   |

When checking idle speed and CO content please note:

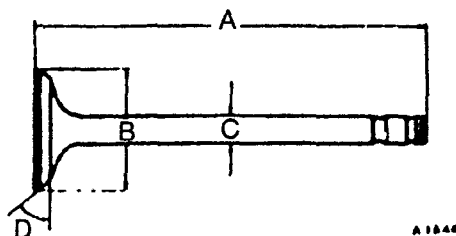
- Electrical consumers switched off
- Engine at operating temperature (oil temperature  $\geq 70^{\circ}\text{C}$ )

\*Ignition adjustment not possible

## CYLINDER HEAD

|  | 14 NV                  | C 16 NZ, C 16 SE                | 18 SE, 20 SEH                    | C 20 XE, C 20 LET  |
|--|------------------------|---------------------------------|----------------------------------|--|
| Cylinder head gasket<br>Thickness — installed                          | 1,75 to 1,90           | 1,15 to 1,30                    | 1,15 to 1,30                     | 1,15 to 1,30   |
| Valve seat width on<br>cylinder head                                   |                        |                                 |                                  |  |
| Inlet  | 1,3 to 1,5             | 1,3 to 1,5                      | 1,0 to 1,5                       | 1,0 to 1,4   |
| Exhaust  | 1,6 to 1,8             | 1,6 to 1,8                      | 1,7 to 2,2                       | 1,4 to 1,8   |
| Valve stem play  |                        |                                 |                                  |  |
| Inlet  | 0,018 to 0,052         | 0,018 to 0,052                  | 0,018 to 0,052                   | 0,03 to 0,06   |
| Exhaust  | 0,038 to 0,072         | 0,038 to 0,072                  | 0,038 to 0,072                   | 0,04 to 0,07   |
| Permissible runout of valve<br>stem to valve cone                      |                        |                                 |                                  |  |
| Inlet valve  | 0,03                   | 0,03                            | 0,03                             | 0,03   |
| Exhaust valve  | 0,03                   | 0,03                            | 0,03                             | 0,03   |
| Overall height of cyl. head<br>(sealing surface to sealing<br>surface) | 95,25 ± 0,45           | 95,25 ± 0,45                    | 95,25 ± 0,45                     | 135,58<br>to<br>135,68   |
| Installation height<br>Inlet and exhaust valves                        | 14,4<br>(Gauge KM-419) | 14,4<br>(Gauge KM-419)          | 17,85 to 18,25<br>(Gauge KM-512) | —<br>Stem upper edge —<br>valve spring disc<br>bearing surface in<br>cylinder head<br>38,50 to 39,70 |
| Installation height  | 80,85 to 81,25         | 80,85 to 81,25                  | 83,50 to 83,80                   | —  |
| Peak-to-valley height of<br>sealing surf.                              | max. 0,025             | max. 0,025                      | max. 0,025                       | max. 0,025   |
| Valve system   |                        | Valve lash adjuster (hydraulic) |                                  |  |
| Valve lifter   |                        | —                               | Exhaust                          |  |
| Valve rotator  |                        |                                 | 0                                |  |
| Valve play in mm   |                        |                                 |                                  |  |
| Installation height, valve<br>guide                                    | —                      | —                               | —                                | 10,70 to 11,00   |

## VALVE DIMENSIONS



| 14 NV           | A in mm |       | B in mm | C (diameter in mm) and Identification |                       |                       |                       | D in ° |
|-----------------|---------|-------|---------|---------------------------------------|-----------------------|-----------------------|-----------------------|--------|
|                 | 1)      | 2)    |         | Standard K                            | Oversize K 1<br>0,075 | Oversize K 2<br>0,150 | Oversize A<br>C,250   |        |
| Inlet valve     | 105     | 104,6 | 33      | $\frac{7,012}{6,998}$                 | $\frac{7,087}{7,073}$ | $\frac{7,162}{7,148}$ | $\frac{7,262}{7,248}$ | 46     |
| Exhaust valve   | 105     | 104,6 | 29      | $\frac{6,992}{6,978}$                 | $\frac{7,067}{7,053}$ | $\frac{7,142}{7,128}$ | $\frac{7,242}{7,228}$ | 46     |
| Valve stem bore |         | —     |         | $\frac{7,050}{7,030}$                 | $\frac{7,125}{7,105}$ | $\frac{7,200}{7,180}$ | $\frac{7,300}{7,280}$ | —      |

1) Production

2) Service

| C 16 NZ, C 16 SE | A in mm |       | B in mm | C (diameter in mm) and Identification |                       |                       |                       | D in ° |
|------------------|---------|-------|---------|---------------------------------------|-----------------------|-----------------------|-----------------------|--------|
|                  | 1)      | 2)    |         | Standard K                            | Oversize K 1<br>0,075 | Oversize K 2<br>0,150 | Oversize A<br>0,250   |        |
| Inlet valve      | 101,5   | 101,1 | 38      | $\frac{7,012}{6,998}$                 | $\frac{7,087}{7,073}$ | $\frac{7,162}{7,148}$ | $\frac{7,262}{7,248}$ | 46     |
| Exhaust valve    | 101,5   | 101,1 | 31      | $\frac{6,992}{6,978}$                 | $\frac{7,067}{7,053}$ | $\frac{7,142}{7,128}$ | $\frac{7,242}{7,228}$ | 46     |
| Valve stem bore  |         | —     |         | $\frac{7,050}{7,030}$                 | $\frac{7,125}{7,105}$ | $\frac{7,200}{7,180}$ | $\frac{7,300}{7,280}$ | —      |

1) Production

2) Service

| 18 SE/20 SEH    | A in mm |       | B in mm | C (diameter in mm) and Identification |                       |                       |                       | D in ° |
|-----------------|---------|-------|---------|---------------------------------------|-----------------------|-----------------------|-----------------------|--------|
|                 | 1)      | 2)    |         | Standard K                            | Oversize K 1<br>0,075 | Oversize K 2<br>0,150 | Oversize A<br>0,250   |        |
| Inlet valve     | 104,2   | 103,8 | 41,8    | $\frac{7,012}{6,998}$                 | $\frac{7,087}{7,073}$ | $\frac{7,162}{7,148}$ | $\frac{7,262}{7,248}$ | 46     |
| Exhaust valve   | 104,2   | 103,6 | 36,5    | $\frac{6,992}{6,978}$                 | $\frac{7,067}{7,053}$ | $\frac{7,142}{7,128}$ | $\frac{7,242}{7,228}$ | 46     |
| Valve stem bore |         | —     |         | $\frac{7,050}{7,030}$                 | $\frac{7,125}{7,105}$ | $\frac{7,200}{7,180}$ | $\frac{7,300}{7,280}$ | —      |

1) Production

2) Service

## VALVE DIMENSIONS

| C 20 XE                  | A in mm |       | B $\phi$ in mm | C ( $\phi$ in mm) and Identification |                       |                       |                       | D in ° |
|--------------------------|---------|-------|----------------|--------------------------------------|-----------------------|-----------------------|-----------------------|--------|
|                          | 1)      | 2)    |                | Standard K                           | Oversize K 1<br>0,075 | Oversize K 2<br>0,150 | Oversize A<br>0,250   |        |
| Intake valve             | 105     | 104,6 | 33 $\pm$ 0,1   | $\frac{6,970}{6,955}$                | $\frac{7,045}{7,030}$ | $\frac{7,120}{7,105}$ | $\frac{7,220}{7,205}$ | 45° 20 |
| Exhaust valve            | 105     | 104,6 | 29 $\pm$ 0,1   | $\frac{6,960}{6,945}$                | $\frac{7,035}{7,020}$ | $\frac{7,110}{7,095}$ | $\frac{7,210}{7,195}$ | 45° 20 |
| Valve stem bore hole     | —       |       |                | $\frac{7,015}{7,000}$                | $\frac{7,090}{7,015}$ | $\frac{7,165}{7,150}$ | $\frac{7,415}{7,400}$ | —      |
| Valve stem projection    | 105     | —     | —              | $\frac{40,3}{39,7}$                  | —                     | —                     | —                     | —      |
| Intake valve dimension F | —       | 104,6 | —              | $\frac{40,7}{40,1}$                  | $\frac{40,3}{39,7}$   | $\frac{40,3}{39,7}$   | —                     | —      |
| Valve stem projection    | 105     | —     | —              | $\frac{40,1}{39,5}$                  | —                     | —                     | —                     | —      |
| Exhaust valve            | —       | 104,6 | —              | $\frac{40,5}{39,9}$                  | $\frac{40,1}{39,5}$   | $\frac{40,1}{39,5}$   | —                     | —      |

1) Production

2) Service

| C 20 LET   | A in mm |       | B $\phi$ in mm | C ( $\phi$ in mm) and Identification mark |                       |                       | D       |
|--|---------|-------|----------------|---|-----------------------|-----------------------|---------|
|  | 1) 2)   | 2)    |                | Standard K                                | Oversize K 1<br>0,075 | Oversize K 2<br>0,150 |         |
| Inlet valve                                      | 105     | 104,6 | 33 $\pm$ 0,1   | $\frac{6,970}{6,955}$                     | $\frac{7,045}{7,030}$ | $\frac{7,120}{7,105}$ | 44° 40' |
| Exhaust valve                                    | 105     | 104,6 | 29 $\pm$ 0,1   | $\frac{6,960}{6,945}$                     | $\frac{7,035}{7,020}$ | $\frac{7,110}{7,095}$ | 44° 40' |
| Valve stem bore                                  | —       |       |                | $\frac{7,015}{7,000}$                     | $\frac{7,090}{7,075}$ | $\frac{7,165}{7,150}$ | —       |
| Valve stem projection inlet valve: dimension E   | 105     | —     | —              | $\frac{39,7}{39,1}$                       | —                     | —                     | —       |
|  | —       | 104,6 | —              | —   | $\frac{39,3}{38,7}$   | $\frac{39,3}{38,7}$   | —       |
| Valve stem projection exhaust valve: dimension F | 105     | —     | —              | $\frac{39,5}{38,9}$                       | —                     | —                     | —       |
|  | —       | 104,6 | —              | —   | $\frac{39,1}{38,5}$   | $\frac{39,1}{38,5}$   | —       |

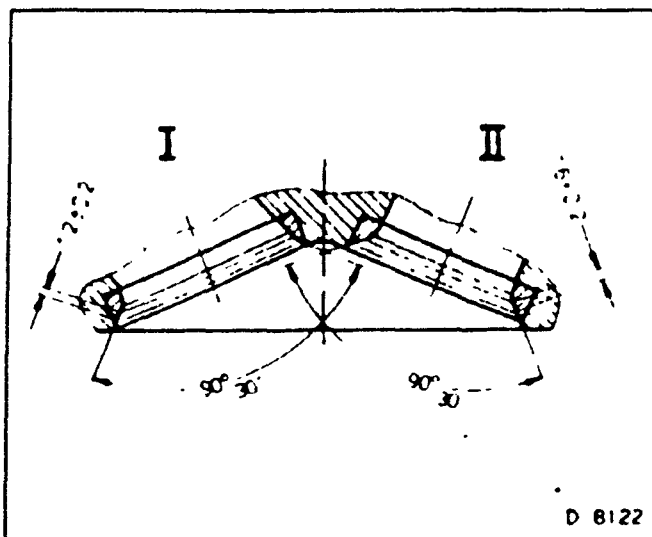
1) Production

2) Service

## VALVE SEAT MACHINING

I = Inlet valve  
II = Exhaust valve

Refacing at valve seat permissible up to 0,4 mm.



## INTAKE AND EXHAUST CAMSHAFTS

| Engine                    |         | C 20 XE/C 20 LET        |
|---------------------------|---------|-------------------------|
| Permissible radial runout | mm      | 0,04                    |
| Permissible end play      | mm      | 0,04 to 0,144           |
| Cam lift                  | mm      | 9,5                     |
| Crankshaft journal        | ∅ in mm | $\frac{27,960}{27,939}$ |
| Diameter in housing       | in mm   | $\frac{28,021}{28,000}$ |

## CAMSHAFT

|                       | 14 NV        | C 16 NZ      | C 16 SE      | 18 SE        | 2,0 SEH      |
|-----------------------|--------------|--------------|--------------|--------------|--------------|
| Identification letter | F            | D            | B            | J            | K            |
| Identification colour |              |              |              |              |              |
| Standard size         | grey         | brown        | white        | —            | —            |
| 0,1 mm undersize      | —            | —            | —            | violet       | violet       |
| Radial runout in mm   | 0,04         | 0,04         | 0,04         | 0,04         | 0,03         |
| End play in mm        | 0,09 to 0,21 | 0,09 to 0,21 | 0,09 to 0,21 | 0,09 to 0,21 | 0,09 to 0,21 |
| Cam stroke in mm      |              |              |              |              |              |
| Inlet                 | 6,12         | 5,61         | 5,61         | 6,67         | 6,67         |
| Exhaust               | 6,12         | 6,12         | 6,12         | 6,67         | —            |

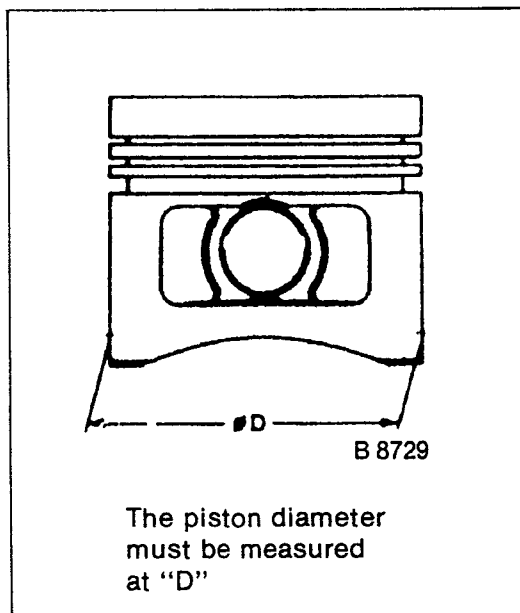
### Grinding dimension for camshaft bearing position

| Bearing | 14 NV, C 16 NZ, C 16 SE        |                     | 18 SE/2,0 SEH                  |               |                     |               |
|---------|--------------------------------|---------------------|--------------------------------|---------------|---------------------|---------------|
|         | Bearing journal diameter in mm | Diameter in housing | Bearing journal diameter in mm |               | Diameter in housing |               |
|         |                                |                     | Standard                       | -0,1 mm       | Standard            | -0,1 mm       |
| 1       | <u>39,455</u>                  | <u>39,525</u>       | <u>42,470</u>                  | <u>42,370</u> | <u>42,525</u>       | <u>42,425</u> |
|         | 39,435                         | 39,500              | 42,455                         | 42,355        | 42,500              | 42,400        |
| 2       | <u>39,705</u>                  | <u>39,775</u>       | <u>42,720</u>                  | <u>42,620</u> | <u>42,775</u>       | <u>42,675</u> |
|         | 39,685                         | 39,750              | 42,705                         | 42,605        | 42,750              | 42,650        |
| 3       | <u>39,955</u>                  | <u>40,025</u>       | <u>42,970</u>                  | <u>42,870</u> | <u>43,025</u>       | <u>42,925</u> |
|         | 39,935                         | 40,000              | 42,955                         | 42,855        | 43,000              | 42,900        |
| 4       | <u>40,205</u>                  | <u>40,275</u>       | <u>43,200</u>                  | <u>43,120</u> | <u>43,275</u>       | <u>43,175</u> |
|         | 40,185                         | 40,250              | 43,205                         | 43,105        | 43,250              | 43,150        |
| 5       | <u>40,455</u>                  | <u>40,525</u>       | <u>43,470</u>                  | <u>43,370</u> | <u>43,525</u>       | <u>43,425</u> |
|         | 40,435                         | 40,500              | 43,455                         | 43,355        | 43,500              | 43,400        |

# Crank Drive

## CYLINDER GRINDING AND PISTON DIMENSIONS

14 NV



|            | Size       | Cylinder                          |                                 | Coefficient for cylinder bore on crankcase | Piston                                |                                 | Coefficient for piston head     |         |
|------------|------------|-----------------------------------|---------------------------------|--|---------------------------------------|---------------------------------|---------------------------------|---------|
|            |            | Cylinder bore $\varnothing$ in mm |                                 |  | Respective piston $\varnothing$ in mm |                                 |                                 |         |
| Production | 1          | <input type="checkbox"/> 77,555   | 77,565                          | 6  | <input type="checkbox"/> 77,535       | 77,545                          | 6                               |         |
|            |            |                                   | 77,575                          | 7  | 77,545                                | 77,555                          | 7                               |         |
|            |            |                                   | 77,585                          | 8  | 77,555                                | 77,565                          | 8                               |         |
|            | 2          |                                   | 77,585                          | 77,595                                     | 99                                    | 77,565                          | 77,575                          | 99      |
|            |            |                                   | 77,595                          | 77,605                                     | 00                                    | 77,575                          | 77,585                          | 00      |
|            |            |                                   | 77,605                          | 77,615                                     | 01                                    | 77,585                          | 77,595                          | 01      |
|            |            |                                   | 77,615                          | 77,625                                     | 02                                    | 77,595                          | 77,608                          | 02      |
|            | 4          |                                   | 77,665                          | 77,675                                     | 07                                    | 77,642                          | 77,658                          | 07      |
|            |            | Service                           | Over-size 0,5 mm                | 78,065                                     | 78,075                                | 7 + 0,5                         | <input type="checkbox"/> 78,042 | 78,058  |
|            | Production | 1                                 | <input type="checkbox"/> 77,775 | 77,785                                     | 8                                     | <input type="checkbox"/> 77,755 | 77,765                          | 8       |
|            |            |                                   |                                 | 77,795                                     | 99                                    | 77,765                          | 77,775                          | 99      |
|            |            | 2                                 |                                 | 77,795                                     | 77,805                                | 00                              | 77,775                          | 77,785  |
|            |            |                                   | 77,805                          | 77,815                                     | 01                                    | 77,785                          | 77,795                          | 01      |
|            |            |                                   | 77,815                          | 77,825                                     | 02                                    | 77,795                          | 77,805                          | 02      |
| Service    |            | Over-size 0,5 mm                  | <input type="checkbox"/> 78,265 | 78,275                                     | 7 + 0,5                               | 78,245                          | 78,255                          | 7 + 0,5 |

inclusive

## CYLINDER GRINDING AND PISTON DIMENSIONS

## C 16 NZ, C 16 SE

|            | Size                | Cylinder                 |        |  | Piston                       |        | Coefficient for piston head |
|------------|---------------------|--------------------------|--------|--|------------------------------|--------|-----------------------------|
|            |                     | Cylinder bore<br>Ø in mm |        | Coefficient for cylinder bore on crankcase | Respective piston<br>Ø in mm |        |                             |
|            |                     | over                     | to     |  | over                         | to     |                             |
| Production | 1                   | □ 78,945                 | 78,955 | 5  | □ 78,925                     | 78,935 | 5                           |
|            |                     | 78,955                   | 78,965 | 6  | 78,935                       | 78,945 | 6                           |
|            |                     | 78,965                   | 78,975 | 7  | 78,945                       | 78,955 | 7                           |
|            |                     | 78,975                   | 78,985 | 8  | 78,955                       | 78,965 | 8                           |
|            | 2                   | 78,985                   | 78,995 | 99   | 78,965                       | 78,975 | 99                          |
|            |                     | 78,995                   | 79,005 | 00   | 78,975                       | 78,985 | 00                          |
|            |                     | 79,005                   | 79,015 | 01   | 78,985                       | 78,995 | 01                          |
|            |                     | 79,015                   | 79,025 | 02   | 78,995                       | 79,005 | 02                          |
|            | 3                   | 79,025                   | 79,035 | 03   | 79,005                       | 79,015 | 03                          |
|            |                     | 79,035                   | 79,045 | 04   | 79,015                       | 79,025 | 04                          |
|            |                     | 79,045                   | 79,055 | 05   | 79,025                       | 79,035 | 05                          |
|            |                     | 79,055                   | 79,065 | 06   | 79,035                       | 79,045 | 06                          |
|            | 4                   | 79,065                   | 79,075 | 07   | 79,045                       | 79,055 | 07                          |
|            |                     | 79,075                   | 79,085 | 08   | 79,055                       | 79,065 | 08                          |
|            |                     | 79,085                   | 79,095 | 09   | 79,065                       | 79,075 | 09                          |
|            |                     | 79,095                   | 79,105 | 1  | 79,075                       | 79,085 | 1                           |
| Service    | Over-size<br>0,5 mm | 79,465                   | 79,475 | 7 + 0,5                                    | 79,445                       | 79,455 | 7 + 0,5                     |
|            |                     | 79,475                   | 79,485 | 8 + 0,5                                    | 79,455                       | 79,465 | 8 + 0,5                     |
|            |                     | 79,485                   | 79,495 | 9 + 0,5                                    | 79,465                       | 79,475 | 9 + 0,5                     |
|            |                     | 79,495                   | 79,505 | 0 + 0,5                                    | 79,475                       | 79,485 | 0 + 0,5                     |

□ inclusive

## 18 SE

|            | Size                | Cylinder                 |  | Piston                       |                             |
|------------|---------------------|--------------------------|--|------------------------------|-----------------------------|
|            |                     | Cylinder bore<br>Ø in mm | Coefficient for cylinder bore on crankcase | Respective piston<br>Ø in mm | Coefficient for piston head |
| Production | 2                   | 84,78                    | 8  | 84,76                        | 8                           |
|            |                     | 84,79                    | 99   | 84,77                        | 99                          |
|            |                     | 84,80                    | 00   | 84,78                        | 00                          |
|            |                     | 84,81                    | 01   | 84,79                        | 01                          |
|            |                     | 84,82                    | 02   | 84,80                        | 02                          |
| Service    | Over-size<br>0,5 mm | 85,27                    | 7 + 0,5                                    | 85,28                        |                             |

## CYLINDER GRINDING AND PISTON DIMENSIONS

## 20 SEH

|            | Size                | Cylinder                 |  | Piston                       |                             |
|------------|---------------------|--------------------------|--|------------------------------|-----------------------------|
|            |                     | Cylinder bore<br>Ø in mm | Coefficient for cylinder bore on crankcase | Respective piston<br>Ø in mm | Coefficient for piston head |
| Production | 2                   | 85,98                    | 8  | 85,96                        | 8                           |
|            |                     | 85,99                    | 99   | 85,97                        | 99                          |
|            |                     | 86,00                    | 00   | 85,98                        | 00                          |
|            |                     | 86,01                    | 01   | 85,99                        | 01                          |
|            |                     | 86,02                    | 02   | 86,00                        | 02                          |
| Service    | Over-size<br>0,5 mm | 86,47                    | 7 + 0,5                                    | 86,45                        |                             |

# Crank Drive

## CYLINDER GRINDING AND PISTON DIMENSIONS C 20 XE

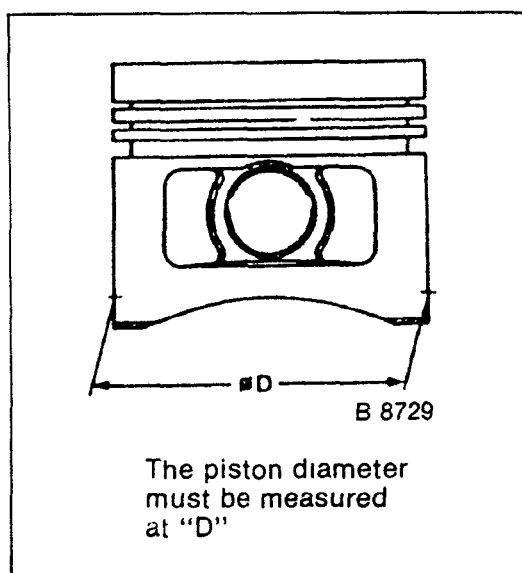
|            | Size                | Cylinder                        |        |  | Piston                          |        | Coefficient for piston head |
|------------|---------------------|---------------------------------|--------|--|---------------------------------|--------|-----------------------------|
|            |                     | Cylinder bore (∅ in mm)         |        | Coefficient for cylinder bore on crankcase | Respective piston (∅ in mm)     |        |                             |
|            |                     | over                            | to     |  |                                 | over   | to                          |
| Production | 1                   | <input type="checkbox"/> 85,975 | 85,985 | 8  | <input type="checkbox"/> 85,945 | 85,955 | 8                           |
|            |                     |                                 | 85,985 | 99   |                                 | 85,965 | 99                          |
|            |                     |                                 | 85,995 | 00   |                                 | 85,975 | 00                          |
|            |                     |                                 | 86,005 | 01   |                                 | 85,985 | 01                          |
| Service    | 2                   | 86,015                          | 86,025 | 02   | 85,985                          | 85,995 | 02                          |
|            | Over-size<br>0,5 mm | 86,465                          | 86,475 | 7 + 0,5                                    | 86,435                          | 86,445 | 7 + 0,5                     |
|            |                     | 86,475                          | 86,485 | 8 + 0,5                                    | 86,445                          | 86,455 | 8 + 0,5                     |
|            |                     | 86,485                          | 86,495 | 9 + 0,5                                    | 86,455                          | 86,465 | 9 + 0,5                     |
|            |                     | 86,495                          | 86,505 | 0 + 0,5                                    | 86,465                          | 86,475 | 0 + 0,5                     |

inclusive

## C 20 LET

|            | Size                | Cylinder                        |        |  | Piston                          |        | Coefficient on piston head |
|------------|---------------------|---------------------------------|--------|--|---------------------------------|--------|----------------------------|
|            |                     | Cylinder bore (∅ in mm)         |        | Coefficient for cylinder bore on crankcase | Related piston (∅ in mm)        |        |                            |
|            |                     | over                            | to     |  |                                 | over   | to                         |
| Production | 1                   | <input type="checkbox"/> 85,975 | 85,985 | 8  | <input type="checkbox"/> 85,915 | 85,925 | 8                          |
|            |                     |                                 | 85,985 | 99   |                                 | 85,935 | 99                         |
|            |                     |                                 | 85,995 | 00   |                                 | 85,945 | 00                         |
|            |                     |                                 | 86,005 | 01   |                                 | 85,965 | 01                         |
| Service    | 2                   | 86,015                          | 86,025 | 02   | 85,955                          | 85,966 | 02                         |
|            | Over-size<br>0,5 mm | 86,465                          | 86,475 | 7 + 0,5                                    | 86,405                          | 86,415 | 7 + 0,5                    |
|            |                     | 86,475                          | 86,485 | 8 + 0,5                                    | 86,415                          | 86,425 | 8 + 0,5                    |
|            |                     | 86,485                          | 86,495 | 9 + 0,5                                    | 86,425                          | 86,436 | 9 + 0,5                    |
|            |                     | 86,495                          | 86,505 | 0 + 0,5                                    | 86,435                          | 86,445 | 0 + 0,5                    |

inclusive





**CYLINDER BORE** **14 NV, C 16 NZ, C 16 SE, 18 SE/20 SEH, 20 XE, 20 LET**

Reboring cylinder Permissible oversize up to 0,5 mm  
(see parts microfiche)

After reboring the cylinders, destroy the original index on the crackcase and stamp in the new oversize index.

Bore

Permissible out-of-round: 0,013\*

Permissible taper: 0,013

\*Measure out-of-round at four different levels of bore.

|  | 14 NV   | C 16 NZ, C 16 SE | 18 SE/20 SEH  | 20 XE         | 20 LET |
|--|---|------------------|---------------|---------------|--------|
| Piston projection above upper edge of cylinder block | 0   | 0,4              | 0,4           | 0             | 0,4    |
| <b>PISTON</b>  | <b>14 NV, C 16 NZ, C 16 SE, 18 SE, 20 SEH</b>   |                  | <b>20 XE</b>  | <b>20 LET</b> |        |
| Version  | Troughed piston   |                  | Forged Piston |               |        |
| Clearance  | In short blocks and cylinder blocks with complete pistons, the piston clearance is 0,02 mm                  |                  | 0,02 — 0,04   | 0,05 — 0,07m  |        |
|  | In rebuilding (oversize), depending upon the piston available a clearance of 0,01 to 0,03 mm is permissible |                  |               | 0,02 — 0,04   |        |

| <b>Piston Rings</b> | <b>14 NV</b>   | <b>C 16 NZ, C 16 SE</b> | <b>18 SE, 20 SEH, 20 XE, 20 LET</b> |
|---------------------|----------------|-------------------------|-------------------------------------|
| Squared ring        |                |                         |                                     |
| Height (mm)         | 1,5            | 1,2                     | 1,5                                 |
| Gap (mm)            | 0,3 to 0,5     | 0,3 to 0,5              | 0,3 to 0,5                          |
| Tapered ring        |                |                         |                                     |
| Height (mm)         | 1,5            | 1,5                     | 1,5                                 |
| Gap (mm)            | 0,3 to 0,5     | 0,3 to 0,5              | 0,3 to 0,5                          |
| Oil scraper ring    |                |                         |                                     |
| Height (mm)         | 3,0            | 3,0                     | 3,0                                 |
| Gap (mm)            | 0,40 to 1,40*) | 0,40 to 1,40*)          | 0,40 to 1,40*)                      |
| Ring gap offset     |                | 180°**)                 |                                     |

\*) Steel band ring gap

\*\*\*) Note that the gap of the top steel band ring is displaced 25 to 50 mm to the left, and that of the bottom one 25 to 50 mm to the right, compared with the gap of the intermediate ring.

| <b>Piston Pins</b> | <b>14 NV</b>                                       | <b>C 16 NZ, C 16 SE</b> | <b>18 SE, 20 SEH</b> | <b>20 XE</b>                | <b>20 LET</b>  |
|--------------------|--|-------------------------|----------------------|-----------------------------|----------------|
| Length             | 55   | 55                      | 61,5                 |                             | 61,5           |
| Diameter           | 18   | 18                      | 21                   |                             | 21             |
| Type               | shrink-fit in con-rod                              |                         |                      | Floating bearing in Con-rod |                |
| Play               |  |                         |                      |                             |                |
| In piston          | 0,007 to 0,010                                     | 0,007 to 0,010          | 0,011 to 0,014       | 0,003 to 0,010              | 0,004 to 0,010 |
| In con-rod         | none   | none                    | none                 | 0,015 to 0,030              | 0,015 to 0,030 |
| Installation       | See operation "Con-rod, Replace" pages 59 and 217. |                         |                      |                             | Sliding seat   |

**CONNECTING ROD** **14 NV, C 16 NZ, C 16 SE, 18 SE/20 SEH, 20 XE, 20 LET**

Permissible weight variation of con-rods without pistons and bearing shells within an engine: 8 g.

As the con-rods have no counterweights, re-working is not possible.

Con-rods must be replaced only as a set.

**18 SE/20 SEH — STANDARD SIZE**

|                                  |             |                         |                         |                         |                         |       |
|----------------------------------|-------------|-------------------------|-------------------------|-------------------------|-------------------------|-------|
| Bearing journals and colour code | from 57,971 |                         |                         |                         |                         |       |
|                                  | to 57,979   |                         |                         |                         |                         | white |
|                                  | over 57,979 |                         |                         |                         |                         | green |
|                                  | to 57,987   |                         |                         |                         |                         |       |
| over 57,987                      | brown       |                         |                         |                         |                         |       |
| to 57,995                        |             |                         |                         |                         |                         |       |
|                                  |             | $\frac{26,002}{25,950}$ | $\frac{48,988}{48,970}$ | $\frac{26,580}{26,460}$ | $\frac{26,390}{26,338}$ |       |

|   |                                    |                                |                           |  |
|---|------------------------------------|--------------------------------|---------------------------|--|
|   | Crankshaft bearing<br>I, II, IV, V | Guide bearing<br>III           | Con-rod bearing<br>1 to 4 |  |
| Bearing shell code<br>Colour code and stamped<br>code<br>identification | brown — 662 N<br>green — 663 N     | brown — 655 N<br>green — 656 N |                           |  |

**18 SE/20 SEH — 0,25 mm UNDERSIZE FOR PRODUCTION AND SERVICE**

|                                 |              |                         |                              |                         |   |                |
|---------------------------------|--------------|-------------------------|------------------------------|-------------------------|---|----------------|
| Bearing journal and colour code | from 57,7320 |                         |                              |                         |   |                |
|                                 | to 57,7385   |                         |                              |                         |   | green/<br>blue |
|                                 | over 57,7385 |                         |                              |                         |   | brown/<br>blue |
|                                 | to 57,7450   |                         |                              |                         |   |                |
|                                 |              | $\frac{26,202}{26,150}$ | $\frac{48,738}{48,720}$ blue | $\frac{26,580}{26,460}$ | — |                |

|  |  |  |                           |  |
|--|--|--|---------------------------|--|
|  | Crankshaft bearing<br>I, II, IV, V       | Guide bearing<br>III                     | Con-rod bearing<br>1 to 4 |  |
| Bearing shell code<br>Colour code and stamped<br>code identification | brown/blue — 664 A<br>green/blue — 665 A | brown/blue — 657 A<br>green/blue — 658 A |                           |  |

**18 SE/20 SEH — 0,50 mm UNDERSIZE FOR SERVICE**

|                                  |              |                         |                               |                         |   |                 |
|----------------------------------|--------------|-------------------------|-------------------------------|-------------------------|---|-----------------|
| Bearing journals and colour code | from 57,4820 |                         |                               |                         |   |                 |
|                                  | to 57,4885   |                         |                               |                         |   | green/<br>white |
|                                  | over 57,4885 |                         |                               |                         |   | brown/<br>white |
|                                  | to 57,4950   |                         |                               |                         |   |                 |
|                                  |              | $\frac{26,402}{26,350}$ | $\frac{48,488}{48,470}$ white | $\frac{26,580}{26,460}$ | — |                 |

|  |  |  |                           |  |
|--|--|--|---------------------------|--|
|  | Crankshaft bearing<br>I, II, IV, V         | Guide bearing<br>III                       | Con-rod bearing<br>1 to 4 |  |
| Bearing shell code<br>Colour code and stamped<br>code identification | brown/white — 666 B<br>green/white — 667 B | brown/white — 659 B<br>green/white — 660 B |                           |  |

**C 20 XE**

|  |   |                          |                            |             |                  |
|--|---|--------------------------|----------------------------|-------------|------------------|
|  | Crankshaft bearing<br>journals<br>I, II, III, IV, V | Guide<br>bearings<br>III | Con-rod journals<br>1 to 4 |             | Con-rod<br>width |
|  | diameter<br>in mm                                   | width<br>in mm           | diameter<br>in mm          | width<br>mm | mm               |

**STANDARD SIZE FOR PRODUCTION AND SERVICE**

|   |              |                         |                         |                         |                         |       |
|---|--------------|-------------------------|-------------------------|-------------------------|-------------------------|-------|
| Crankshaft and con-rod<br>bearing journals<br>Colour code | from 57,9740 |                         |                         |                         |                         |       |
|   | to 57,9810   |                         |                         |                         |                         | white |
|   | over 57,9810 |                         |                         |                         |                         | green |
|   | to 57,9880   |                         |                         |                         |                         |       |
| over 57,9880  | brown        |                         |                         |                         |                         |       |
| to 57,9950  |              |                         |                         |                         |                         |       |
|   |              | $\frac{26,002}{25,950}$ | $\frac{48,988}{48,970}$ | $\frac{26,580}{26,460}$ | $\frac{26,390}{26,338}$ |       |

|                                    | Crankshaft bearing<br>I, II, IV, V | Guide bearings<br>III           | Con-rod journals<br>1 to 4      |
|------------------------------------|------------------------------------|---------------------------------|---------------------------------|
| Bearing shells colour top:<br>code | brown                              | brown                           |                                 |
| below:                             | green                              | green<br>white                  |                                 |
| Bearing shells code top:           | GM 74, GM 985<br>GM15<br>662 N     | GM 74, GM 985<br>GM 15<br>655 N |                                 |
| below:                             |                                    | GM 74, GM 985<br>GM 15<br>656 N |                                 |
|                                    |                                    | GM 74, GM 985<br>GM 15<br>663 N | GM 74, GM 985<br>GM 15<br>126 N |

### 0,25 mm UNDERSIZE FOR PRODUCTION AND SERVICE

|   |  |                         |                         |                         |                         |
|---|--|-------------------------|-------------------------|-------------------------|-------------------------|
| Crankshaft and con-rod<br>bearing journals<br>Colour code | from 57,7320 green/<br>to 57,7385 blue<br>over 57,7385 brown/<br>to 57,7450 blue | <u>26,202</u><br>26,150 | <u>48,738</u><br>48,720 | <u>26,580</u><br>26,460 | <u>26,390</u><br>26,338 |
|---|--|-------------------------|-------------------------|-------------------------|-------------------------|

|                                    | Crankshaft bearing<br>I, II, IV, V | Guide bearings<br>III            | Con-rod journals<br>1 to 4 |
|------------------------------------|------------------------------------|----------------------------------|----------------------------|
| Bearing shells colour top:<br>code | brown/blue                         | brown/blue                       |                            |
| below:                             | green/blue                         | green/blue                       | blue                       |
| Bearing shells code*) top:         | GM 74, GM 985,<br>GM 15<br>664 A   | GM 74, GM 985,<br>GM 15<br>657 A |                            |
| below:                             | GM 74, GM 985,<br>GM 15<br>665 A   | GM 74, GM 985,<br>GM 15<br>658 A |                            |

\*Alternatively

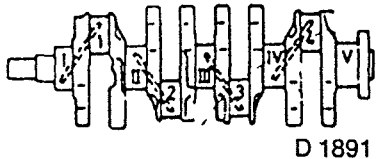
### 0,25 mm UNDERSIZE FOR SERVICE

|   |  |                         |                         |                         |                         |
|---|--|-------------------------|-------------------------|-------------------------|-------------------------|
| Crankshaft and con-rod<br>bearing journals<br>Colour code | from 57,4820 green/<br>to 57,4885 white<br>over 57,4885 brown/<br>to 57,4950 white | <u>26,402</u><br>26,350 | <u>48,488</u><br>48,470 | <u>26,580</u><br>26,460 | <u>26,390</u><br>26,338 |
|---|--|-------------------------|-------------------------|-------------------------|-------------------------|

|                                    | Crankshaft bearing<br>I, II, IV, V | Guide bearings<br>III            | Con-rod journals<br>1 to 4 |
|------------------------------------|------------------------------------|----------------------------------|----------------------------|
| Bearing shells colour top:<br>code | brown/white                        | brown/white                      |                            |
| below:                             | green/white                        | green/white                      |                            |
| Bearing shells code*) top:         | GM 74, GM 985,<br>GM 15<br>666 B   | GM 74, GM 985,<br>GM 15<br>659 B |                            |
| below:                             | GM 74, GM 985,<br>GM 15<br>661 B   | GM 74, GM 985,<br>GM 15<br>660 B |                            |

\*Alternatively

**CRANKSHAFT GRINDING DIMENSIONS 20 LET**

|  |  |                      |                            |                |               |
|--|--|----------------------|----------------------------|----------------|---------------|
| <br>D 1891 | Crankshaft journals<br>I, II, III, IV, V | Guide bearing<br>III | Con-rod journals<br>1 to 4 |                | Con-rod width |
|  | diameter<br>in mm                        | width<br>in mm       | diameter<br>in mm          | width<br>in mm | mm            |

**STANDARD SIZE**

|                                  |                    |        |        |        |        |
|----------------------------------|--------------------|--------|--------|--------|--------|
| Bearing journals and colour code | from 57,9620 green | 26,002 | 48,988 | 26,580 | 26,390 |
|                                  | to 57,9885         |        |        |        |        |
|                                  | over 57,9885 brown | 25,950 | 48,970 | 26,460 | 26,338 |
|                                  | to 57,9950         |        |        |        |        |

|  |                                    |                                |                           |  |
|--|------------------------------------|--------------------------------|---------------------------|--|
|  | Crankshaft bearing<br>I, II, IV, V | Guide bearing<br>III           | Con-rod bearing<br>1 to 4 |  |
| Bearing shell code<br>Colour code and stamped code | brown — 662 N<br>green — 663 N     | brown — 655 N<br>green — 656 N | —                         |  |

**0,25 mm UNDERSIZE FOR PRODUCTION AND SERVICE**

|                                  |                    |        |        |        |        |
|----------------------------------|--------------------|--------|--------|--------|--------|
| Bearing journals and colour code | from 57,7320 green | 26,202 | 48,738 | 26,580 | 26,390 |
|                                  | to 57,7385 blue    |        |        |        |        |
|                                  | over 57,7385 brown | 26,150 | 48,720 | 26,460 | 26,338 |
|                                  | to 57,7450 blue    |        |        |        |        |

|  |  |  |                           |  |
|--|--|--|---------------------------|--|
|  | Crankshaft bearing<br>I, II, IV, V             | Guide bearing<br>III                           | Con-rod bearing<br>1 to 4 |  |
| Bearing shell code<br>Colour code and stamped code | brown/blue<br>— 664 A<br>green/blue<br>— 665 A | brown/blue<br>— 657 A<br>green/blue<br>— 658 A | blue                      |  |

**0,50 mm UNDERSIZE FOR SERVICE**

|                                  |                    |        |        |        |        |
|----------------------------------|--------------------|--------|--------|--------|--------|
| Bearing journals and colour code | from 57,4820 green | 26,402 | 48,488 | 26,580 | 26,390 |
|                                  | to 57,4885 white   |        |        |        |        |
|                                  | over 57,4885 brown | 26,350 | 48,470 | 26,460 | 26,338 |
|                                  | to 57,4950 white   |        |        |        |        |

|  |  |  |                           |  |
|--|--|--|---------------------------|--|
|  | Crankshaft bearing<br>I, II, IV, V               | Guide bearing<br>III                             | Con-rod bearing<br>1 to 4 |  |
| Bearing shell code<br>Colour code and stamped code | brown/white<br>— 666 B<br>green/white<br>— 667 B | brown/white<br>— 659 B<br>green/white<br>— 660 B | white                     |  |



# Carburettor

## 2 E 3 CARBURETTOR IDENTIFICATION DATA/CALIBRATION

|   |                       |                             |                    |                    |
|---|-----------------------|-----------------------------|--------------------|--------------------|
| <b>ENGINE</b>                                   |                       |                             | <b>14 NV</b>       |                    |
| Output in kW (HP)                               |                       |                             | 55 (75)            |                    |
| Transmission                                    |                       |                             | MT                 |                    |
| Code number                                     |                       |                             | 90 107 912         |                    |
| Colour code                                     | Cover bolts           |                             | grey               |                    |
|   | Automatic choke bolts |                             | white              |                    |
| Main nozzle                                     |                       |                             | 1st stage<br>X 95  | 2nd stage<br>X 110 |
| Air correction nozzle                           |                       |                             | X 117,5            | X 90               |
| Mixture pipe code number                        |                       |                             | 103                | 51                 |
| Pre-atomizer/mixture outflow                    |                       | ∅ in mm                     | 8/2,5              | 7/3,0              |
| Idle fuel/air nozzle                            |                       |                             | 45/130             | —                  |
| Partial load enrichment                         |                       | ∅ in mm                     | 0,55               | —                  |
| Fuel full load enrichment                       |                       |                             |                    | 80                 |
| Cowl  |                       | ∅ in mm                     | 20                 | 24                 |
| Choke valve gap                                 | "small"               | mm                          | 1,7 — 2,1          | —                  |
|   | "large"               | mm                          | 2,5 — 2,9          | —                  |
| Throttle valve gap                              |                       |                             | 0,8 — 0,9          | 0,05               |
| Throttle valve dashpot                          | stroke "H"            | mm                          | —                  | —                  |
| Forced opening of choke valve                   |                       | mm                          | 1,5 — 3,5          | —                  |
| Fast idle speed                                 |                       | rpm                         | 2200 — 2600        | —                  |
| Tie rod pre-tension                             |                       | mm                          | —                  | 0,5 — 2,0          |
| Release of forced return                        | Dim. "Y"              | mm                          | —                  | 0,5 — 1,1          |
|   | Dim. "Z"              | mm                          | —                  | 0,1 — 0,7          |
| Float needle valve                              |                       | ∅ in mm                     | 1,5                | —                  |
| Float weight (dry)                              |                       | g                           | 5,75 — 5,95        | —                  |
| Float level                                     |                       | mm                          | 28 — 30            | —                  |
| Injection quantity                              |                       | cm <sup>3</sup> /10 strokes | 10,5 — 13,5        | —                  |
| Vacuum unit code number                         |                       |                             |                    | 44/50              |
| Pulldown unit code number                       |                       |                             | 59                 | —                  |
| Stepped disc code number                        |                       |                             | 201                | —                  |
| Pump diaphragm code number                      |                       |                             | 85                 | —                  |
| Part load enrichment valve code number          |                       |                             | 17                 | —                  |
| Fuel transition system                          |                       |                             | —                  | —                  |
| Part load enrichment valve switching point      |                       | mbar                        | 200 ± 40           | 2,0                |
| Vacuum unit reduction                           |                       | ∅ in mm                     |                    | 0,6                |
| Choke switch-off time at approximately 14 volts |                       | s                           | 144 — 216          |                    |
| Height of enrichment pipe over pre-atomizer     |                       | mm                          | 22 — 24            |                    |
| Thermo-time valve Passage closed                |                       | °C                          | below approx. + 28 |                    |
|   |                       | °C                          | above approx. + 35 |                    |
| Resistance (at 20 to 30°C)                      |                       | ohms                        | 4,5 — 7,5          |                    |
| Change-over time (at 20°C)                      |                       | s                           | 7 ± 3              |                    |
| Idle speed                                      |                       | rpm                         | 925 ± 25           |                    |
| CO content                                      |                       | vol %                       | 1,0 ± 0,5          |                    |

## Injection Systems

### MULTEC CENTRAL FUEL INJECTION (C 16 NZ)

|                   |                    |
|-------------------|--------------------|
| Fuel pressure:    | 1,00 bar           |
| Fuel pump:        |                    |
| Operating voltage | 7 — 15 volts       |
| Supply quantity   | 85 l/h at 12 volts |

---

### MOTRONIC M 1.5.4 (C 14 SE, C 16 SE)

|                   |                    |
|-------------------|--------------------|
| Fuel pressure:    | 3,0 bar            |
| Fuel pump:        |                    |
| Operating voltage | 7 — 15 volts       |
| Supply quantity   | 85 l/h at 12 volts |

---

### MOTRONIC M 1.5.4 (18 SE/ 20 SEH)

|  |                    |               |
|--|--------------------|---------------|
| Fuel pressure:                                       | Feed:              | 1,8 — 2,2 bar |
|  | Return:            | 0,3 — 1,5 bar |
| Vacuum hose for fuel pressure regulator disconnected | Feed:              | 2,5 — 3,0 bar |
|  | Return:            | 0,3 — 1,5 bar |
| Fuel pump:   |                    |               |
| Operating voltage                                    | 7 — 15 volts       |               |
| Supply quantity                                      | 85 l/h at 12 volts |               |

---

### MOTRONIC 1.5.4 (20 XE)

|  |                    |
|--|--------------------|
| Fuel pump:   |                    |
| Operating voltage                                  | 7 — 15 volts       |
| Supply quantity                                    | 85 l/h at 12 volts |
| Fuel pressure (feed)                               |                    |
| Vacuum hose for fuel pressure regulator connected: | 2,0 — 2,2 bar      |
| disconnected:                                      | 2,3 — 2,7 bar      |

### MOTRONIC M 2,7 (20 LET)

|  |               |                     |
|--|---------------|---------------------|
| Operating voltage                                  | Fuel pump:    | 7 — 15 volts        |
| Supply quantity                                    |               | 100 l/h at 12 volts |
| Fuel pressure (feed)                               |               |                     |
| Vacuum hose for fuel pressure regulator connected: | 2,2 — 2,7 bar |                     |
| disconnected:                                      | 3,0 — 3,5 bar |                     |

Use Checking Procedures for checks of individual components.

**Starter****ENGINE****BOSCH**

|          |              |
|----------|--------------|
| 14 NV    | 12V, 0,85 kW |
| C 16 SE  | 12V, 0,9 kW  |
| C 16 NZ  | 12V, 0,9 kW  |
| C 18 NZ  | 12V, 1,4 kW  |
| C 20 SEH | 12V, 1,4 kW  |
| C 20 XE  | 12V, 1,4 kW  |

**TEST DATA (BOSCH)**

|  |                    | 90 458 462                           |           | 90 458 462                           |                         |
|--|--------------------|--------------------------------------|-----------|--------------------------------------|-------------------------|
| Opel Part No                             |                    | 90 458 462                           |           | 90 458 462                           |                         |
| Bosch code number                        |                    | 0 001 108 079                        |           | 0 001 112 015                        |                         |
| Type                                     |                    | DW → 12 V, 1,4 kW                    |           | DM → 12 V, 0,9 kW                    |                         |
| Idle speed check                         | Current (amps)     | < 75                                 |           | < 45                                 |                         |
|  | Engine speed (rpm) | > 2900                               |           | > 5500                               |                         |
|  | Voltage (volts)    | 11,5                                 |           | 11,5                                 |                         |
| Short circuit check                      | Voltage (volts)    | 3,2                                  | 4,2       | 5,7 <sup>1)</sup>                    | 6,7 <sup>1)</sup>       |
|  | Current (amps)     | 430 — 550                            | 580 — 750 | 350 — 450 <sup>1)</sup>              | 400 — 500 <sup>1)</sup> |
| Min. voltage for actuat. solenoid switch | Voltage (volts)    | 8,0 <sup>2)</sup> /7,3 <sup>3)</sup> |           | 8,0 <sup>2)</sup> /7,3 <sup>3)</sup> |                         |
| Collector diameter                       | (mm)               | 31,2                                 |           | 33,5                                 |                         |
| Minimum length of brushes                | (mm)               | 8,0                                  |           | 3,0                                  |                         |

<sup>1)</sup> Check with 2 x 143 Ah parallel to 10 m series resistor (E FAL 152/153 connection 30/2)

<sup>2)</sup> Checking value for relay 0 331 303 505, ..563

<sup>3)</sup> Checking value for relay 0 331 302 553, ...559



# Alternator

## CHARACTERISTICS

| ENGINE           | STRENGTH OF CURRENT<br>IN A | Type           | BOSCH<br>Ident No. |
|------------------|-----------------------------|----------------|--------------------|
| 14 NV            | 55                          | K1 14V 55A 20  | 0 120 488 159      |
| 14 NV            | 70                          | K1 14V 28/70 A | 0 120 488 191      |
| C 14 SE, C 16 NZ | 70                          | K1 14V 28/70 A | 0 120 488 201*     |
| C 16 SE          | 70                          | —              | —                  |
| C 20 XE          | 70                          | —              | 0 120 488 202      |

\*In connection with power steering

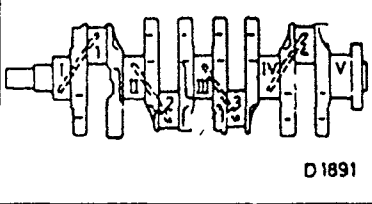
## TEST DATA (BOSCH)

| Code number                              | 0 120 488 159    | 0 120 488 191    | 0 120 488 193  |
|--|------------------|------------------|----------------|
| Type                                     | K1 → 14V 55 A 20 | K1 → 14V 28/70 A | K1 14V 28/70 A |
| Voltage rating in volts                  | 14               | 14               | 14             |
| Maximum current output in amps           | 55               | 70               | 70             |
| Current output in amps at                |                  |                  |                |
| 1500 rpm                                 | 10 <sup>1)</sup> | 28               | 27             |
| 2000 rpm                                 | 36               | —                | 46             |
| 6000 rpm                                 | 55               | 70               | 70             |
| Alternator regulator (electric)          |                  |                  |                |
| Regulator voltage in volts at            |                  |                  |                |
| 4000 rpm and under 1 minute              | 13,7 — 14,5      | 14,1 — 14,9      | 13,7 — 14,5    |
| with test loading in amps                | 5,0 — 7,0        | 10               | 10             |
| Minimum diameter of slip rings in mm     | 31,5             | 27,2             | 31,5           |
| Protrusion of carbon brushes in mm       | 5                | min. 5           | 11 — 12        |
| Resistance of excitation winding in ohms | 3,4 + 10%        | 2,6 + 10%        | 2,8 + 10%      |
| Resistance of starter winding in ohms    | 0,14 + 10%       | 0,1 + 10%        | max. 0,1 + 10% |
| Alternator connection                    |                  | Y configuration  |                |
| Torque of housing nuts in Nm             | 3,5 — 5,5        | 4,1 — 5,5        | 4,1 — 5,5      |
| Torque of pulley nut in Nm               | 35 — 45          | 50 ± 5           | 35 — 45        |

<sup>1)</sup> At 1200 rpm

## TEST DATA (BOSCH)

| Code number                              | 0 120 488 201            | 0 120 488 255            |
|--|--------------------------|--------------------------|
| Type                                     | K1 → 14V 28/70 A         | K1 → 14V 28/70 A         |
| Opel Part No.                            | 90 337 797<br>90 349 324 | 90 414 497<br>90 442 072 |
| Voltage rating in volts                  | 14                       | 14                       |
| Maximum current output in amps           | 70                       | 70                       |
| Current output in amps at                |                          |                          |
| 1500 rpm                                 | 28                       | 28                       |
| 6000 rpm                                 | 70                       | 70                       |
| Alternator regulator (electric)          |                          |                          |
| Regulator voltage in volts at            |                          |                          |
| 4000 rpm and under 1 minute              | 14,1 — 14,9              | 14,1 — 14,9              |
| with test loading in amps                | 10                       | 10                       |
| Minimum diameter of slip rings in mm     | 27,2                     | 27,2                     |
| Protrusion of carbon brushes in mm       | min. 5                   | min. 5                   |
| Resistance of excitation winding in ohms | 2,6 + 10%                | 2,6 + 10%                |
| Resistance of starter winding in ohms    | 0,1 + 10%                | 0,1 + 10%                |
| Alternator connection                    | Y configuration          | Y configuration          |
| Torque of housing nuts in Nm             | 4,1 — 5,5                | 4,1 — 5,5                |
| Torque of pulley nut in Nm               | 50 ± 5                   | 50 ± 5                   |

|  | Crankshaft bearing journals<br>I, II, III, IV, V | Guide bearings<br>III   | Con-rod journals<br>1 to 4 |                |                 | Con-rod<br>width        |                         |
|--|--|-------------------------|----------------------------|----------------|-----------------|-------------------------|-------------------------|
|  | diameter<br>in mm                                | width<br>in mm          | diameter<br>in mm          |                |                 | width<br>in mm          | in mm                   |
| <b>14 NV, C 16 NZ, C 16 SE</b>   | <b>STANDARD SIZE FOR PRODUCTION AND SERVICE</b>  |                         |                            |                |                 |                         |                         |
| Crankshaft and<br>con-rod bearing journals                                       | <u>54,997</u><br>54,980                          | <u>26,052</u><br>26,000 | <u>42,987</u><br>42,971    |                |                 | <u>22,080</u><br>21,960 | <u>21,890</u><br>21,838 |
| Colour code  | none   |                         | none                       |                |                 |                         |                         |
| Bearing shells colour code<br>top:<br>below:                                     | brown<br>green                                   |                         | brown<br>green             |                | none            |                         |                         |
| Bearing shells code*<br>top:   | GM 400<br>221 N                                  | GM 15<br>256 N          | GM 400<br>225 N            | GM 15<br>859 N | GM 400<br>529 N | GM 124<br>582 N         | GM 40 R<br>766 N        |
| below:   | GM 400<br>201 N                                  | GM 15<br>257 N          | GM 400<br>205 N            | GM 15<br>860 N |                 |                         |                         |

\*Alternatively

| <b>14NV, C 16 NZ, C 16 SE</b>                | <b>0,25 mm UNDERSIZE FOR PRODUCTION AND SERVICE</b> |                         |                          |                |                 |                         |                         |
|--|---|-------------------------|--------------------------|----------------|-----------------|-------------------------|-------------------------|
| Crankshaft and<br>con-rod bearing journals   | <u>54,747</u><br>54,730                             | <u>26,252</u><br>26,200 | <u>42,737</u><br>42,721  |                |                 | <u>22,080</u><br>21,960 | <u>21,890</u><br>21,838 |
| Colour code                                  | blue  |                         | blue                     |                |                 |                         |                         |
| Bearing shells colour code<br>top:<br>below: | brown-blue<br>green-blue                            |                         | brown-blue<br>green-blue |                | blue            |                         |                         |
| Bearing shells code*<br>top                  | GM 400<br>222 A                                     | GM 15<br>258 A          | GM 400<br>226 A          | GM 15<br>861 A | GM 400<br>530 A | GM 124<br>583 A         | GM 40 R<br>767 A        |
| below.                                       | GM 400<br>202 A                                     | GM 15<br>259 A          | GM 400<br>206 A          | GM 15<br>862 A |                 |                         |                         |

| <b>0,50 mm UNDERSIZE FOR PRODUCTION AND SERVICE</b> |                            |                         |                            |                |                 |                         |                         |
|---|----------------------------|-------------------------|----------------------------|----------------|-----------------|-------------------------|-------------------------|
| Crankshaft and<br>con-rod bearing journals          | <u>54,495</u><br>54,482    | <u>26,452</u><br>26,400 | <u>42,487</u><br>42,471    |                |                 | <u>22,080</u><br>21,960 | <u>21,890</u><br>21,838 |
| Colour code   | white                      |                         | white                      |                |                 |                         |                         |
| Bearing shells colour code<br>top:<br>below:        | brown-white<br>green-white |                         | brown-white<br>green-white |                | white           |                         |                         |
| Bearing shells code*<br>top                         | GM 400<br>223 B            | GM 15<br>260 B          | GM 400<br>227 B            | GM 15<br>863 B | GM 400<br>531 B | GM 124<br>584 B         | GM 40 R<br>768 B        |
| below.  | GM 400<br>203 B            | GM 15<br>261 B          | GM 400<br>207 B            | GM 15<br>864 B |                 |                         |                         |

# Recommended Torque Values

## 1,4 / 1,6 LTR. ENGINE

|  | Nm                                   |
|--|--------------------------------------|
| Alternator to bracket (M 10) .....   | 40                                   |
| Alternator to bracket (M 8) .....  | 30                                   |
| Bracket for alternator to cylinder block (M 10) .....  | 40                                   |
| Bracket for oil intake pipe to cylinder block .....  | 8                                    |
| Camshaft housing cover to housing .....  | 8                                    |
| Camshaft sprocket to camshaft .....  | 45                                   |
| Con-rod bearing cover to con-rod (see position <sup>4</sup> )                                      |                                      |
| Crankshaft bearing cover to cylinder block .....   | 50 + 45° + 15° <sup>1)</sup>         |
| Crankshaft pulley with toothed belt drive pinion to crankshaft (M 10 — see position <sup>9</sup> ) |                                      |
| Crankshaft pulley with toothed belt drive pinion to crankshaft (M 12) .....                        | 95 + 30° + 15°                       |
| Cylinder head to cylinder block .....  | 55 + 60° + 60° + 30° <sup>1)3)</sup> |
| Exhaust manifold to cylinder head .....  | 22                                   |
| Flywheel to crankshaft .....   | 35 + 30° + 15° <sup>1)</sup>         |
| Front exhaust pipe to exhaust manifold .....   | 25                                   |
| Front toothed belt cover to rear toothed belt cover .....  | 4                                    |
| Fuel pump to camshaft housing .....  | 18                                   |
| Intake manifold to cylinder head .....   | 22                                   |
| Left engine bracket to transmission .....  | 60                                   |
| Left engine damping block to engine bracket .....  | 60                                   |
| Oil drain plug to oil pan .....  | 45                                   |
| Oil filter cartridge to connection fitting (cylinder block) .....                                  | 15                                   |
| Oil intake pipe to cylinder block .....  | 8 <sup>5)</sup>                      |
| Oil intake pipe to oil pump .....  | 8 <sup>5)</sup>                      |
| Oil pan to cylinder block .....  | 8 <sup>5)8)</sup>                    |
| Oil pressure switch/sensor to oil pump .....   | 30                                   |
| Oil pump to cylinder block .....   | 6                                    |
| Oxygen sensor to exhaust manifold (Multec only) .....  | 30 <sup>7)</sup>                     |
| Preheater scoop to exhaust manifold .....  | 8                                    |
| Pressure plate for camshaft to camshaft housing .....  | 8                                    |
| Pulley to pump for power steering .....  | 25                                   |
| Pump for power steering to engine block .....  | 30                                   |
| Rear engine bracket to transmission .....  | 60 <sup>2)</sup>                     |
| Rear engine damping block to crossmember .....   | 40                                   |
| Rear engine damping block to engine bracket .....  | 45                                   |
| Rear toothed belt cover to camshaft housing and oil pump housing .....                             | 12                                   |
| Right and left engine damping blocks to side member .....  | 65 <sup>5)</sup>                     |
| Right engine bracket to cylinder block .....   | 60                                   |
| Right engine damping block to engine bracket .....   | 35                                   |
| Screw plug for relief pressure valve to oil pump .....   | 30                                   |
| Spark plugs to cylinder head .....   | 25                                   |
| Starter to cylinder block .....  | 25                                   |
| Temperature sensor to intake manifold .....  | 10                                   |
| Tension strap to alternator and intake manifold .....  | 25                                   |
| Thermostat housing to cylinder head .....  | 10                                   |
| Toothed belt tension roller to oil pump .....  | 20                                   |
| Transmission to cylinder block .....   | 75                                   |
| Water pump to cylinder block (M 6) .....   | 8                                    |

- 1) Use new bolt (s).
- 2) Use new tab washers.
- 3) After test run turn a further  $30^{\circ} + 15^{\circ}$ .
- 4) Tighten bolt (thread length 15 mm) 6 22 412 (02 865 514) to 28 Nm.  
Tighten bolt (thread length 40 mm) 6 22 431 (90 281 728) to 25 Nm +  $30^{\circ}$  1).
- 5) Bolt must be recut before reusing and inserted using Locking Compound (Loctite 242).
- 6) Tighten bolt (thread length 23 mm) 20 00 560 (11 073 353) to 55 Nm.  
Tighten bolt (thread length 30 mm) 6 14 938 (90 299 605) to 55 Nm +  $45^{\circ} + 15^{\circ}$  (use new bolt).
- 7) Insert using Special Grease.
- 8) Installation time max. 10 mins.

## Recommended Torque Values

### 1,8 / 2,0 LTR. ENGINE

|  | Nm                             |
|--|--------------------------------|
| Alternator to bracket (M 10) . . . . .                                     | 35                             |
| Alternator to bracket (M 8) . . . . .                                      | 30                             |
| Bracket for alternator to cylinder block (M 10) . . . . .                  | 40                             |
| Bracket for alternator to cylinder block (M 8) . . . . .                   | 25                             |
| Bracket for oil intake pipe to cylinder block . . . . .                    | 6                              |
| Bracket for servo pump to cylinder block . . . . .                         | 40                             |
| Camshaft housing cover to housing . . . . .                                | 8                              |
| Camshaft sprocket to camshaft . . . . .                                    | 45                             |
| Con-rod bearing cover to con-rod . . . . .                                 | 35 + 45° + 15° <sup>1)</sup>   |
| Crankshaft bearing cover to cylinder block . . . . .                       | 50 + 45° + 15° <sup>1)</sup>   |
| Crankshaft pulley to toothed belt drive pinion . . . . .                   | 20                             |
| Crankshaft pulley to torsional damper . . . . .                            | 25                             |
| Cylinder head to cylinder block . . . . .                                  | 25+60°+60°+60° <sup>1)2)</sup> |
| Engine transport strap to camshaft housing . . . . .                       | 15                             |
| Exhaust manifold to cylinder head . . . . .                                | 22                             |
| Exhaust pipe to exhaust manifold . . . . .                                 | 25                             |
| Flywheel to crankshaft . . . . .   | 65 + 30° + 15° <sup>1)</sup>   |
| Intake manifold to cylinder head . . . . .                                 | 22                             |
| Left engine bracket to transmission . . . . .                              | 60                             |
| Left engine damping block to engine bracket . . . . .                      | 60                             |
| Oil drain plug to oil pan . . . . .  | 45                             |
| Oil filter cartridge to oil pump . . . . .                                 | 15                             |
| Oil intake pipe to oil pump . . . . .                                      | 8 <sup>4)</sup>                |
| Oil pan to cylinder block . . . . .  | 5 <sup>4)</sup>                |
| Oil pressure switch to oil pump . . . . .                                  | 40                             |
| Oil pump to cylinder block . . . . .                                       | 6                              |
| Oxygen sensor to exhaust manifold (Multec only) . . . . .                  | 30 <sup>3)</sup>               |
| Preheater scoop to exhaust manifold . . . . .                              | 8                              |
| Pressure plate for camshaft housing . . . . .                              | 8                              |
| Rear engine bracket to transmission . . . . .                              | 60 <sup>2)</sup>               |
| Rear engine damping block to crossmember . . . . .                         | 40                             |
| Rear engine damping block to engine bracket . . . . .                      | 45                             |
| Rear toothed belt cover to oil pump housing and camshaft housing . . . . . | 6                              |
| Right and left engine damping blocks to side member . . . . .              | 65 <sup>4)</sup>               |
| Right engine bracket to cylinder block . . . . .                           | 60                             |
| Right engine damping block to engine bracket . . . . .                     | 35                             |
| Screw plug for relief pressure valve to oil pump . . . . .                 | 30                             |
| Spark plugs to cylinder head . . . . .                                     | 25                             |
| Starter to cylinder block — engine side (M 10) . . . . .                   | 45                             |
| Starter to cylinder block — transmission side . . . . .                    | 75                             |
| Support for starter to cylinder block . . . . .                            | 25                             |
| Temperature sensor to intake manifold . . . . .                            | 10                             |
| Tension strap to alternator and intake manifold . . . . .                  | 25                             |
| Thermostat housing to cylinder head . . . . .                              | 15                             |
| Toothed belt drive pinion to crankshaft . . . . .                          | 130 + 40° to 50° <sup>1)</sup> |
| Torsional damper to toothed belt drive pinion . . . . .                    | 20                             |
| Transmission to cylinder block . . . . .                                   | 75                             |
| Water outlet connection to thermostat housing . . . . .                    | 8                              |
| Water pump to cylinder block (M 8) . . . . .                               | 25                             |

<sup>1)</sup> Use new bolt(s).

<sup>2)</sup> Use new tab washers.

<sup>3)</sup> After test run turn a further 30° + 15°.

<sup>4)</sup> Bolt must be recut before reusing and inserted using Locking Compound (Loctite 242).

<sup>5)</sup> Insert using Special Grease.


## Recommended Torque Values

### DOHC 16V — 2,0 XE/2,0LET

|  | Nm                                 |
|--|------------------------------------|
| AC compressor to auxiliary components support                              | 35 <sup>3)</sup>                   |
| Adapter (threaded coupling) for oil cooler to oil pump                     | 23 <sup>1)</sup>                   |
| Alternator retaining strap to intake pipe                                  | 25                                 |
| Auxiliary components support to cylinder block                             | 35 <sup>3)</sup>                   |
| Bracket power steering hydraulic pump/AC compressor to cylinder block      | 35                                 |
| Bracket to AC compressor   | 20 <sup>3)</sup>                   |
| Brake servo vacuum line to intake pipe                                     | 20                                 |
| Camshaft bearing cover (rear) to cylinder head (M 6)                       | 10                                 |
| Camshaft bearing cover to cylinder head (M 8)                              | 20                                 |
| Camshaft pulley to camshaft  | 50 + 60° + 15° <sup>4)</sup>       |
| Closure screw (safety valve) to oil pump                                   | 30                                 |
| Closure screw to oil temperature regulator housing (M20)                   | 30                                 |
| Con-rod bearing cover to con-rod   | 35 + 45° + 15° <sup>4)</sup>       |
| Coolant feed line to turbocharger  | 20 <sup>9)</sup>                   |
| Coolant pipe to cylinder block   | 20                                 |
| Coolant return line to turbocharger  | 20 <sup>9)</sup>                   |
| Cover to throttle valve manifold   | 5 <sup>9)</sup>                    |
| Cover plate to cylinder head (bolts M 6)                                   | 9                                  |
| Cover plate to cylinder head (nuts M 8)                                    | 22 <sup>109)</sup>                 |
| Crankshaft bearing cover to cylinder block                                 | 50 + 45° + 15° <sup>4)</sup>       |
| Crankshaft pulley to toothed belt drive gear                               | 20 <sup>9)</sup>                   |
| Cylinder head cover to cylinder head                                       | 8                                  |
| Cylinder head to cylinder block  | 25 + 90° + 90° + 90° <sup>9)</sup> |
| Engine damping block bracket to engine holder                              | 60 <sup>4)</sup>                   |
| Engine damping block bracket to support                                    | 60 <sup>4)</sup>                   |
| Engine damping block to bracket  | 60                                 |
| Engine suspension bracket to cylinder block                                | 60                                 |
| Exhaust diverter manifold to turbocharger                                  | 20 <sup>9)</sup>                   |
| Exhaust manifold to cylinder head  | 22 <sup>2)</sup>                   |
| Exhaust manifold with turbocharger to cylinder head                        | 25 <sup>2)9)</sup>                 |
| Exhaust pipe to exhaust diverter manifold                                  | 12 <sup>2)9)</sup>                 |
| Fastening bolts to exhaust joint   | 20                                 |
| Flywheel to crankshaft   | 65 + 30° + 15° <sup>4)</sup>       |
| Front toothed belt cover to cylinder head, intermediate piece and oil pump | 8                                  |
| High-performance header with cover plate to cylinder head                  | 22                                 |
| Ignition lead cover to cylinder head cover                                 | 8                                  |
| Inductive pulse pick-up to cylinder block                                  | 6                                  |
| Intake pipe to cylinder head   | 22                                 |
| Intermediate shaft bracket to cylinder block                               | 55                                 |
| Knock sensor to cylinder block   | 20                                 |
| Lower alternator fastening (M 10)  | 40                                 |
| Lower alternator fastening   | 35 <sup>3)</sup>                   |
| Oil cooler lines to adapter  | 30                                 |
| Oil cooler lines to cooler   | 30                                 |
| Oil draining screw to oil pan  | 45                                 |
| Oil feed line to cylinder block screw connection                           | 12 <sup>9)</sup>                   |

|   |                                |
|---|--------------------------------|
| Oil filter element to oil pump . . . . .  | 15                             |
| Oil intake pipe bracket to cylinder block . . . . .                                 | 6                              |
| Oil intake pipe to oil pump . . . . .   | 8 <sup>1)</sup>                |
| Oil pan to cylinder block . . . . .   | 15 <sup>6)</sup>               |
| Oil pressure switch to oil pump . . . . .   | 40                             |
| Oil pump cover to oil pump . . . . .  | 6                              |
| Oil pump to cylinder block . . . . .  | 6                              |
| Oil temperature switch to cylinder block . . . . .                                  | 30                             |
| Oxygen sensor to front exhaust pipe . . . . .                                       | 30 <sup>5)</sup>               |
| Pot flywheel to crankshaft . . . . .  | 65 + 30° + 15° <sup>4)</sup>   |
| Power steering hydraulic pump to support . . . . .                                  | 25 <sup>3)</sup>               |
| Rear toothed belt cover to cylinder block . . . . .                                 | 6                              |
| Retaining strap to alternator . . . . .   | 25                             |
| Ribbed V-belt pulley to toothed belt drive gear . . . . .                           | 20 <sup>3)</sup>               |
| Ribbed V-belt tension roller to support . . . . .                                   | 18 <sup>3)</sup>               |
| Right engine damping block to side member . . . . .                                 | 65 <sup>1)</sup>               |
| Shackle for power steering hydraulic pump to auxiliary components support . . . . . | 8 <sup>3)</sup>                |
| Shackle to intake pipe and alternator . . . . .                                     | 18 <sup>3)</sup>               |
| Spark plug to cylinder head . . . . .   | 25                             |
| Starter to cylinder block (engine side) . . . . .                                   | 45                             |
| Starter to cylinder block (transmission side) . . . . .                             | 60                             |
| Support to intake pipe and alternator . . . . .                                     | 18 <sup>3)</sup>               |
| Thermostat housing to cylinder head . . . . .                                       | 15                             |
| Toothed belt drive gear to crankshaft . . . . .                                     | 250 + 40° to 50° <sup>4)</sup> |
| Toothed belt guide roller bracket to cylinder block . . . . .                       | 25 <sup>3)</sup>               |
| Toothed belt guide roller to cylinder block . . . . .                               | 25 + 45° + 15° <sup>6)</sup>   |
| Toothed belt guide roller to cylinder block . . . . .                               | 25 <sup>3)</sup>               |
| Toothed belt guide roller to guide roller bracket . . . . .                         | 25 <sup>3)</sup>               |
| Toothed belt tension roller to cylinder block . . . . .                             | 25 + 45° + 15° <sup>6)</sup>   |
| Toothed belt tension roller to oil pump . . . . .                                   | 20 <sup>3)</sup>               |
| Transmission to cylinder block . . . . .  | 75                             |
| V-belt pulley to toothed belt drive gear . . . . .                                  | 20                             |
| Water outlet connection to thermostat housing . . . . .                             | 8                              |
| Water pump to cylinder block . . . . .  | 25                             |

<sup>1)</sup> Recut threads and insert bolts with Locking Compound Locktite 242  
<sup>2)</sup> Use new nuts  
<sup>3)</sup> On engines as of MY '93  
<sup>4)</sup> Use new bolt(s)  
<sup>5)</sup> Insert with Special Grease 19 48 602 (5 613 695)  
<sup>6)</sup> Installation time max 10 min  
<sup>7)</sup> Insert bolt with grease  
<sup>8)</sup> Additional tightening not required  
<sup>9)</sup> C20LET only  
<sup>10)</sup> Not present in C20LET

**Opel Astra  Opel Kadett**

**Workshop Manual**

**Section K**

**Clutch —  
Manual Transmission  
and  
Automatic Transmissior**

Issued by: Service Division  
Delta Motor Corporation  
August 1993



## Index

|   | Page |
|---|------|
| <b>MANUAL TRANSMISSION AND DIFFERENTIAL</b>   |      |
| ILLUSTRATIONS I — GEAR SETS, DIFFERENTIAL, CLUTCH, TRANSMISSION SHIFT LINKAGE . . . . . | K- 5 |
| ILLUSTRATIONS II — SECTIONED ILLUSTRATIONS . . . . .                                    | K-14 |
| TRANSMISSION IDENTIFICATION . . . . .   | K-18 |
| <b>CHECKING AND ADJUSTING OPERATIONS</b>  |      |
| TAPERED ROLLER BEARING (DIFFERENTIAL), PRESCRIBED ADJUSTMENT . . . . .                  | K-58 |
| TRANSMISSION FLUID LEVEL, CHECK . . . . .   | K-19 |
| TRANSMISSION SHIFT LINKAGE, ADJUST . . . . .  | K-20 |
| <b>OPERATIONS ON TRANSMISSION SHIFT LINKAGE</b>   |      |
| FOLDING COVER ON SHIFT LINKAGE, REPLACE . . . . .                                       | K-24 |
| MANUAL SHIFT LEVER, REMOVE AND INSTALL . . . . .  | K-21 |
| RUBBER CAP FOR MANUAL SHIFT LEVER, REMOVE AND INSTALL . . . . .                         | K-21 |
| SELECTOR ROD, REPLACE . . . . .   | K-25 |
| SHIFT COVER, ASSEMBLE AND INSTALL . . . . .   | K-28 |
| SHIFT COVER, REMOVE AND DISASSEMBLE . . . . .   | K-27 |
| SHIFT GUIDE, REMOVE AND INSTALL . . . . .   | K-25 |
| SHIFT LINKAGE LEVER, REMOVE AND INSTALL . . . . .                                       | K-25 |
| SHIFT LINKAGE, REMOVE AND INSTALL . . . . .   | K-22 |
| <b>SEALING OPERATIONS ON INSTALLED TRANSMISSION</b>                                     |      |
| AXLE SHAFT SEAL RINGS, REPLACE . . . . .  | K-30 |
| GASKET FOR DIFFERENTIAL COVER, REPLACE . . . . .  | K-35 |
| GASKET FOR END SHIELD, REPLACE . . . . .  | K-33 |
| GASKET FOR SHIFT COVER, REPLACE . . . . .   | K-33 |
| RUBBER O-RING FOR SPEEDOMETER HELICAL GEAR (DRIVEN), REPLACE . . . . .                  | K-32 |
| <b>OPERATIONS ON MANUAL TRANSMISSION AND DIFFERENTIAL</b>                               |      |
| DRIVE GEAR (DRIVING) — REMOVE AND INSTALL . . . . .                                     | K-88 |
| DRIVE GEARS (DRIVING AND DRIVEN), REMOVE AND INSTALL . . . . .                          | K-81 |
| F28/6 MANUAL TRANSMISSION — SWITCH FOR 1ST GEAR RECOGNITION — SEAL OR REPLACE . . . . . | K-37 |
| — REVERSING LAMP SWITCH — SEAL OR REPLACE . . . . .                                     | K-37 |
| MANUAL TRANSMISSION AND DIFFERENTIAL, REMOVE AND INSTALL . . . . .                      | K-38 |
| TRANSMISSION HOUSING, REPLACE . . . . .   | K-44 |
| <b>DIFFERENTIAL, OVERHAUL</b>   |      |
| DIFFERENTIAL, ASSEMBLE AND INSTALL  |      |
| F 10/F 13 . . . . .   | K-54 |
| F 16/F 20 . . . . .   | K-55 |
| DIFFERENTIAL, REMOVE AND DISASSEMBLE  |      |
| F 10/F 13 . . . . .   | K-48 |
| F 16/F 20 . . . . .   | K-50 |
| <b>MANUAL TRANSMISSION, OVERHAUL</b>  |      |
| BEARING RINGS IN TRANSMISSION HOUSING, REPLACE  |      |
| F 10/F 13 . . . . .   | K-73 |
| F 16/F 20 . . . . .   | K-75 |

|  |      |
|--|------|
| DRIVE SHAFT, ASSEMBLE  |      |
| F 10/F 13 .....  | K-81 |
| F 16/F 20 .....  | K-82 |
| DRIVE SHAFT, DISASSEMBLE .....   | K-69 |
| END SHIELD, ASSEMBLE .....   | K-82 |
| END SHIELD WITH MAIN SHAFT AND DRIVE SHAFT, REMOVE AND DISASSEMBLE ..... | K-62 |
| MAIN SHAFT, ASSEMBLE   |      |
| F 10/F 13 .....  | K-76 |
| F 16/F 20 .....  | K-78 |
| MAIN SHAFT, DISASSEMBLE  |      |
| F 10/F 13 .....  | K-70 |
| F 16/F 20 .....  | K-71 |
| SPEEDOMETER HELICAL GEAR (DRIVEN), REMOVE AND INSTALL .....              | K-89 |
| SPEEDOMETER HELICAL GEAR (DRIVING), REMOVE AND INSTALL .....             | K-89 |
| SYNCHRONIZER RINGS, REPLACE .....  | K-86 |

## CLUTCH

|   |      |
|---|------|
| BEARING BUSHINGS FOR CLUTCH RELEASE LEVER, REMOVE AND INSTALL ..... | K-95 |
| CLUTCH CABLE, REPLACE .....   | K-96 |
| CLUTCH DISC AND PRESSURE PLATE, REMOVE AND INSTALL .....            | K-90 |
| CLUTCH PEDAL, REMOVE AND INSTALL .....                              | K-98 |
| CLUTCH PRESSURE BEARING AND RELEASE LEVER, REMOVE AND INSTALL ..... | K-95 |

## Index

|  | Page  |
|--|-------|
| <b>AUTOMATIC TRANSMISSION AF 20</b>  |       |
| ILLUSTRATIONS .....  | K-100 |
| IMPORTANT INSTRUCTIONS FOR OPERATIONS ON AUTOMATIC TRANSMISSIONS .....             | K-104 |
| TRANSMISSION IDENTIFICATION .....  | K-105 |
| <b>CHECKING AND ADJUSTING OPERATIONS</b>   |       |
| *ELECTRICAL CHECK  |       |
| FLUID PRESSURE CHECK (MECHANICAL) .....  | K-108 |
| KICKDOWN SWITCH, ADJUST .....  | K-112 |
| SELECTOR ACTUATION CABLE, ADJUST .....   | K-110 |
| SELECTOR LEVER POSITION SWITCH, ADJUST .....                                       | K-107 |
| SELECTOR LEVER POSITION SWITCH, CHECK .....  | K-106 |
| TRANSMISSION FLUID LEVEL, CHECK .....  | K-106 |
| <b>OPERATIONS ON TRANSMISSION SHIFT LINKAGE</b>                                    |       |
| BULB/SOCKET FOR LIGHTING, REMOVE AND INSTALL .....                                 | K-120 |
| DRIVING MODE SWITCH, REMOVE AND INSTALL  |       |
| — “WINTER” .....   | K-120 |
| — “SPORT” .....  | K-121 |
| KICKDOWN SWITCH, REMOVE AND INSTALL .....  | K-121 |
| SELECTOR ACTUATION CABLE, REMOVE AND INSTALL .....                                 | K-122 |
| SELECTOR LEVER ASSEMBLY, REMOVE AND INSTALL .....                                  | K-123 |
| SELECTOR LEVER CONSOLE, REMOVE AND INSTALL .....                                   | K-124 |
| *See Checking Procedures “Opel Electronic 4-speed Automatic Transmission AF 14/20” |       |
| <b>OPERATIONS ON INSTALLED TRANSMISSION</b>  |       |
| AUXILIARY HOUSING COVER AND/OR GASKET, REPLACE .....                               | K-118 |
| AXLE SHAFT SEAL RINGS, REPLACE .....   | K-113 |
| GASKET FOR SIDE COVER, REPLACE .....   | K-118 |
| SEAL RINGS FOR CHECK BORE (FLUID PRESSURE), REPLACE .....                          | K-117 |
| TRANSMISSION, REMOVE AND INSTALL .....   | K-128 |
| ELECTRONIC CONTROL UNIT, REMOVE AND INSTALL .....                                  | K-110 |
| FLUID COOLER LINES, CONNECTING HOSE AND/OR SEAL RINGS, REPLACE .....               | K-117 |
| FLUID FILLER PIPE AND/OR GASKET, REPLACE .....                                     | K-115 |
| FLUID TEMPERATURE SENSOR AND/OR GASKET, REPLACE .....                              | K-116 |
| SENSOR — TRANSMISSION INPUT/OUTPUT SPEED, REMOVE AND INSTALL .....                 | K-116 |
| SOLENOID VALVE WIRING HARNESS, REPLACE .....                                       | K-113 |
| SOLENOID VALVES OR FLUID PRESSURE REGULATOR, REMOVE AND INSTALL .....              | K-112 |
| SPEEDOMETER HELICAL GEAR (DRIVEN) AND/OR SEAL RING, REPLACE .....                  | K-115 |
| <b>OPERATIONS ON REMOVED TRANSMISSION</b>  |       |
| CONVERTER AND/OR FLUID PUMP SEAL RING, REPLACE .....                               | K-126 |
| HOUSING PARTS AND/OR GASKET, REPLACE .....   | K-126 |
| <b>TRANSMISSION, OVERHAUL</b>  |       |
| ILLUSTRATIONS .....  | K-135 |
| ASSEMBLIES, REMOVE FROM TRANSMISSION .....   | K-138 |
| ATTACHING PARTS FROM TRANSMISSION, REMOVE .....                                    | K-138 |

|   |       |
|---|-------|
| ASSEMBLIES, DISASSEMBLE AND ASSEMBLE .....              | K-151 |
| DIFFERENTIAL, OVERHAUL .....                            | K-193 |
| FLUID PUMP, MULTI-DISC BRAKES B1 AND B2, OVERHAUL ..... | K-151 |
| FREEWHEEL F1, OVERHAUL .....                            | K-159 |
| INTERMEDIATE DRIVE GEAR, CHECK .....                    | K-181 |
| MULTI-DISC BRAKE B3 AND FREEWHEEL F2, OVERHAUL ..       | K-170 |
| MULTI-PLATE CLUTCH ASSEMBLY C1 AND C2, OVERHAUL .       | K-163 |
| MULTI-PLATE CLUTCH C3 AND FREEWHEEL F3, OVERHAUL .....  | K-173 |
| PLANETARY GEAR SET P1, OVERHAUL .....                   | K-167 |
| PLANETARY GEAR SET P2, OVERHAUL .....                   | K-183 |
| REAR COVER WITH PISTON C1, OVERHAUL .....               | K-190 |
| REDUCTION BRAKE, OVERHAUL .....                         | K-178 |
| VALVE BODY, OVERHAUL .....                              | K-199 |
| ASSEMBLIES, INSTALL IN TRANSMISSION .....               | K-225 |
| <b>SPECIAL SERVICE TOOLS</b> .....                      | K-241 |
| <b>TECHNICAL DATA</b> .....                             | K-263 |

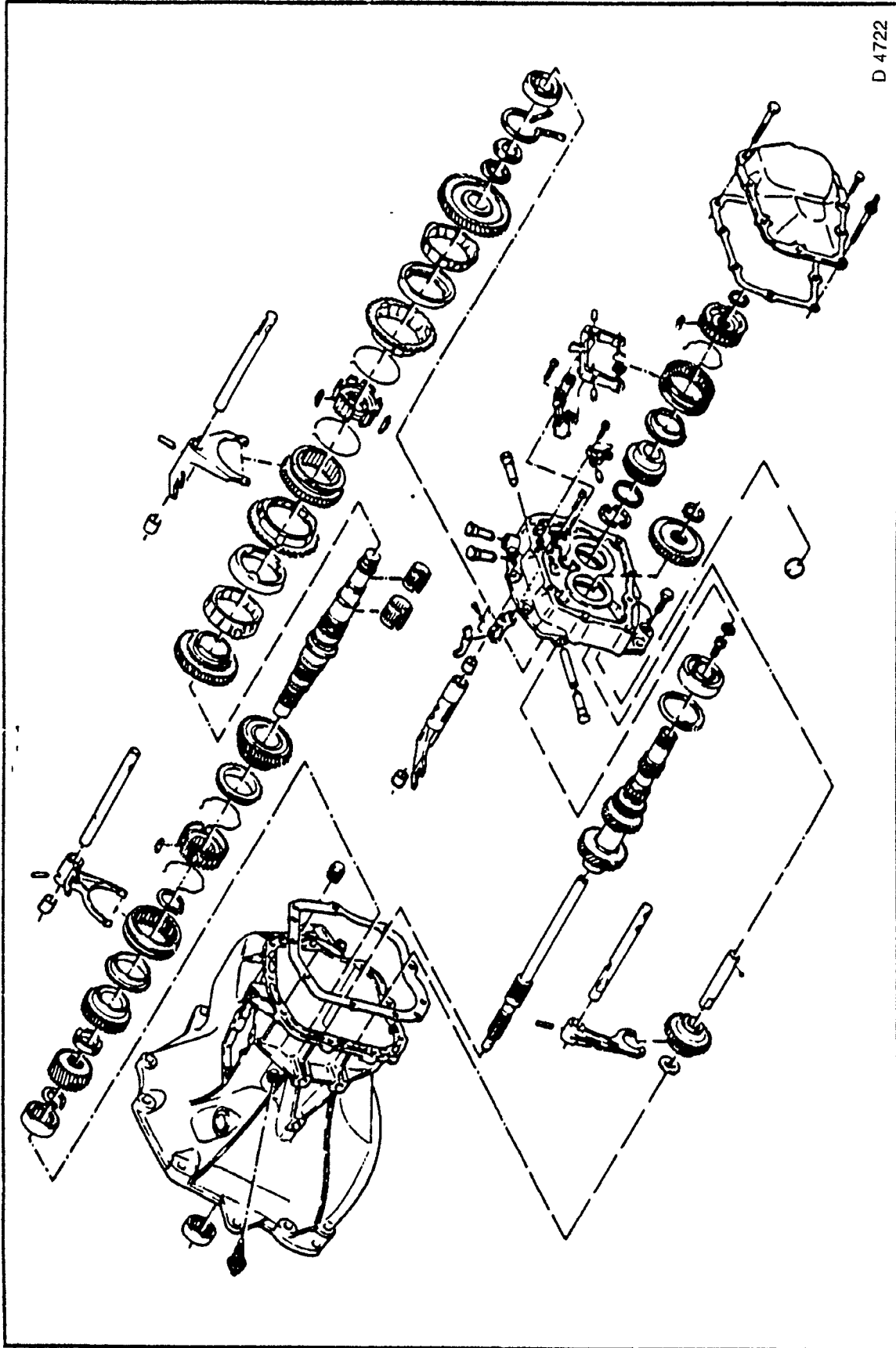
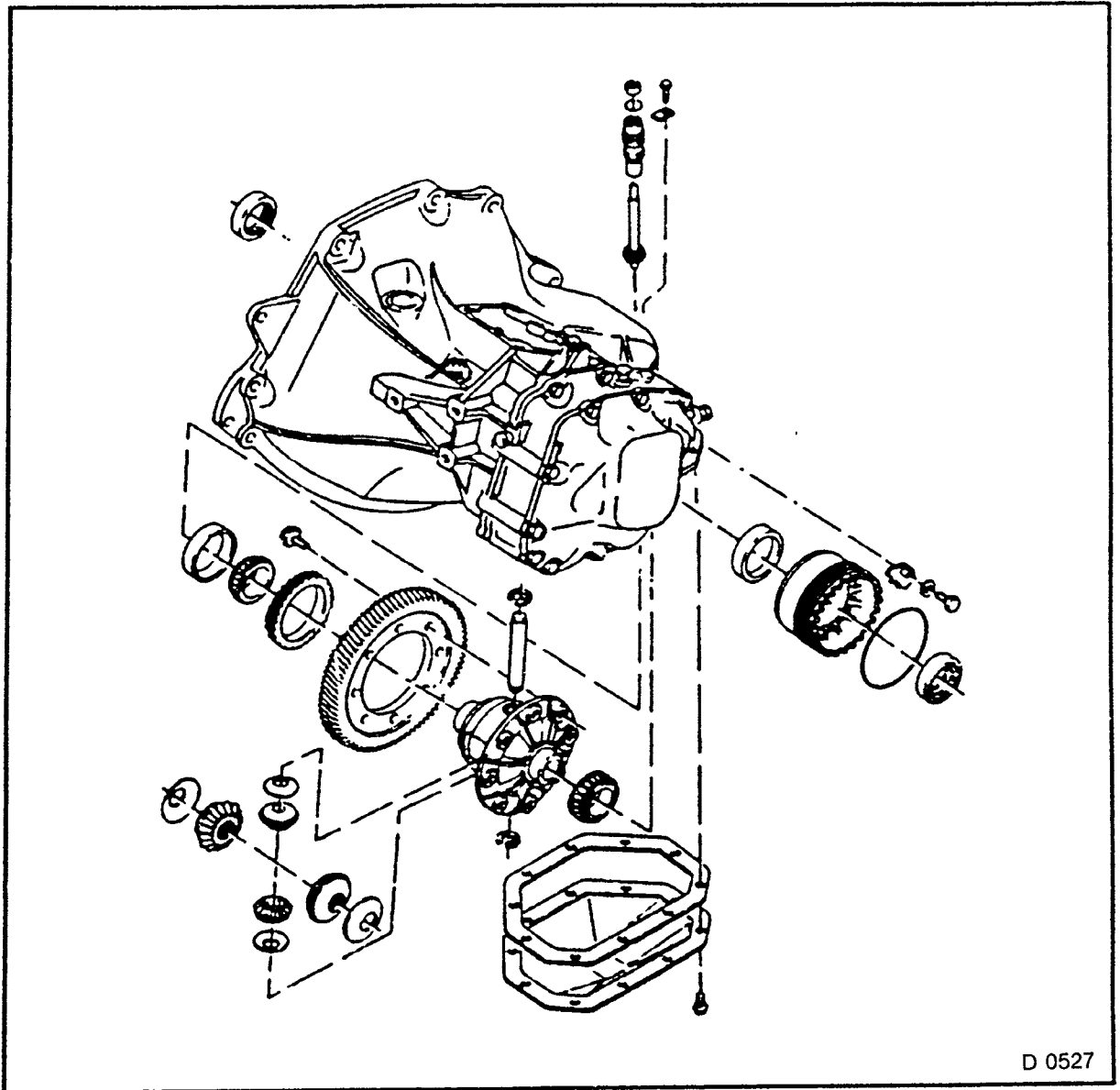


Fig 1 — Manual Transmission F 10/5, F 13/5



D 0527

Fig. 2 — Differential F 10, F 13

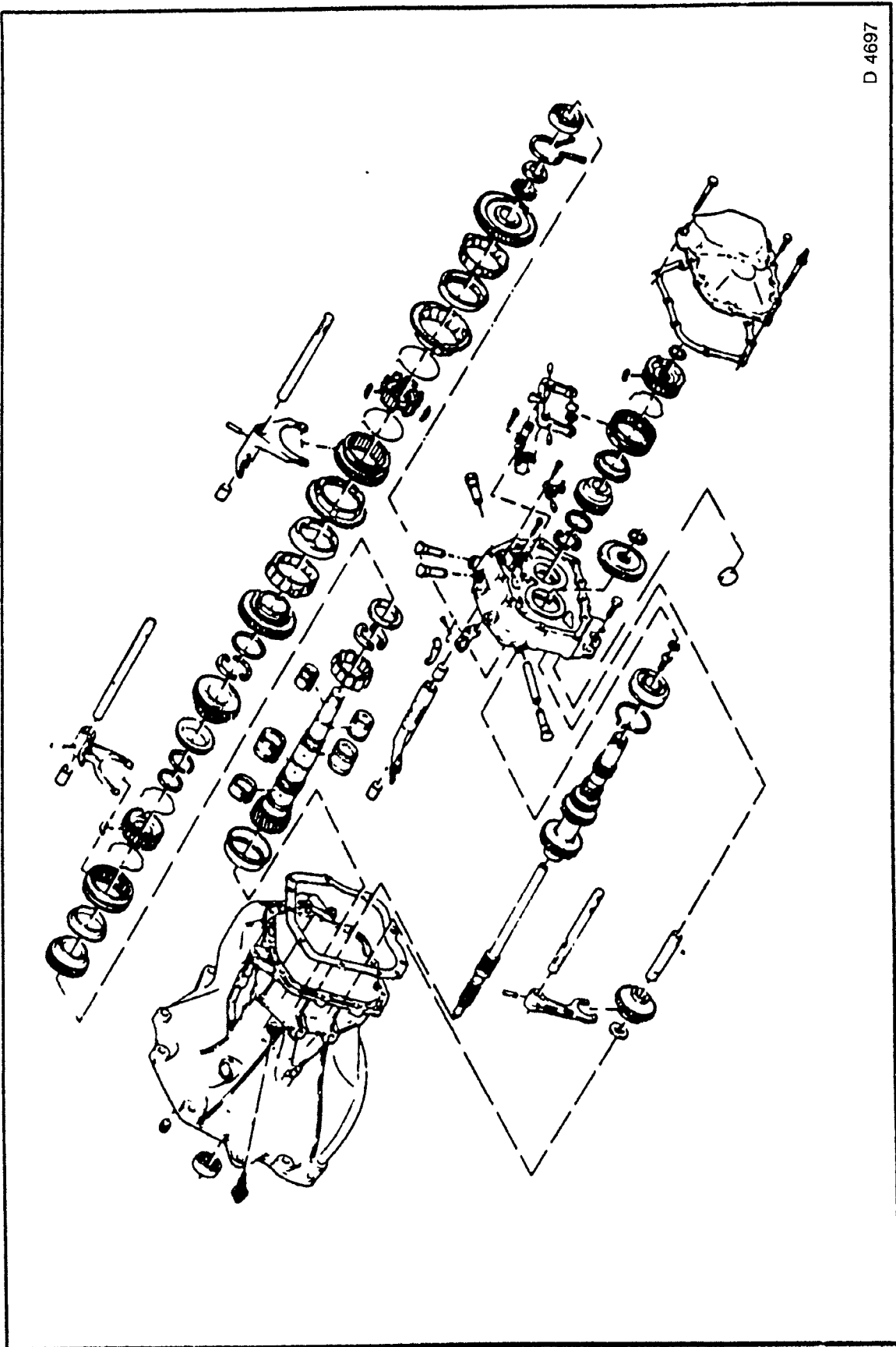
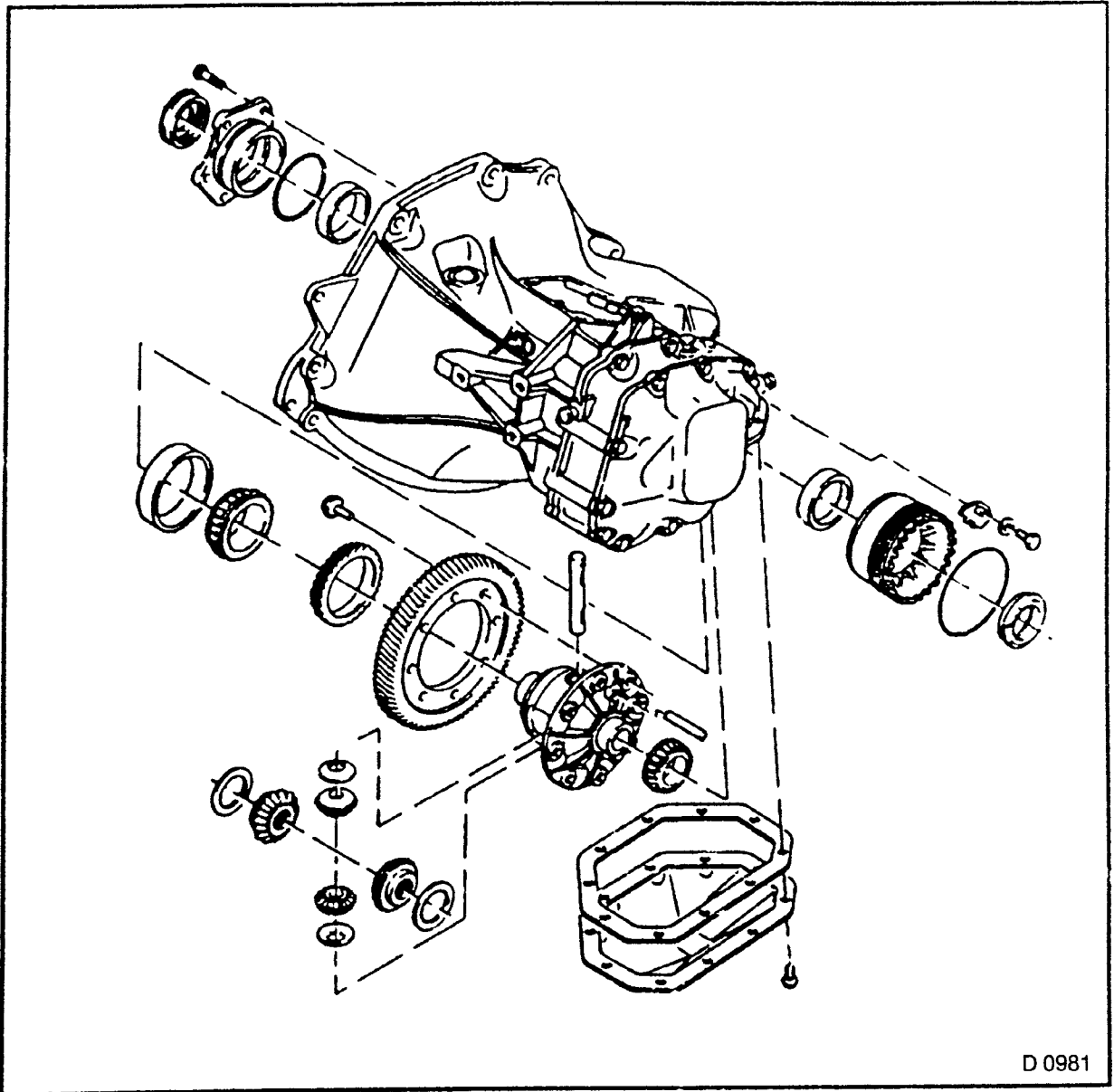


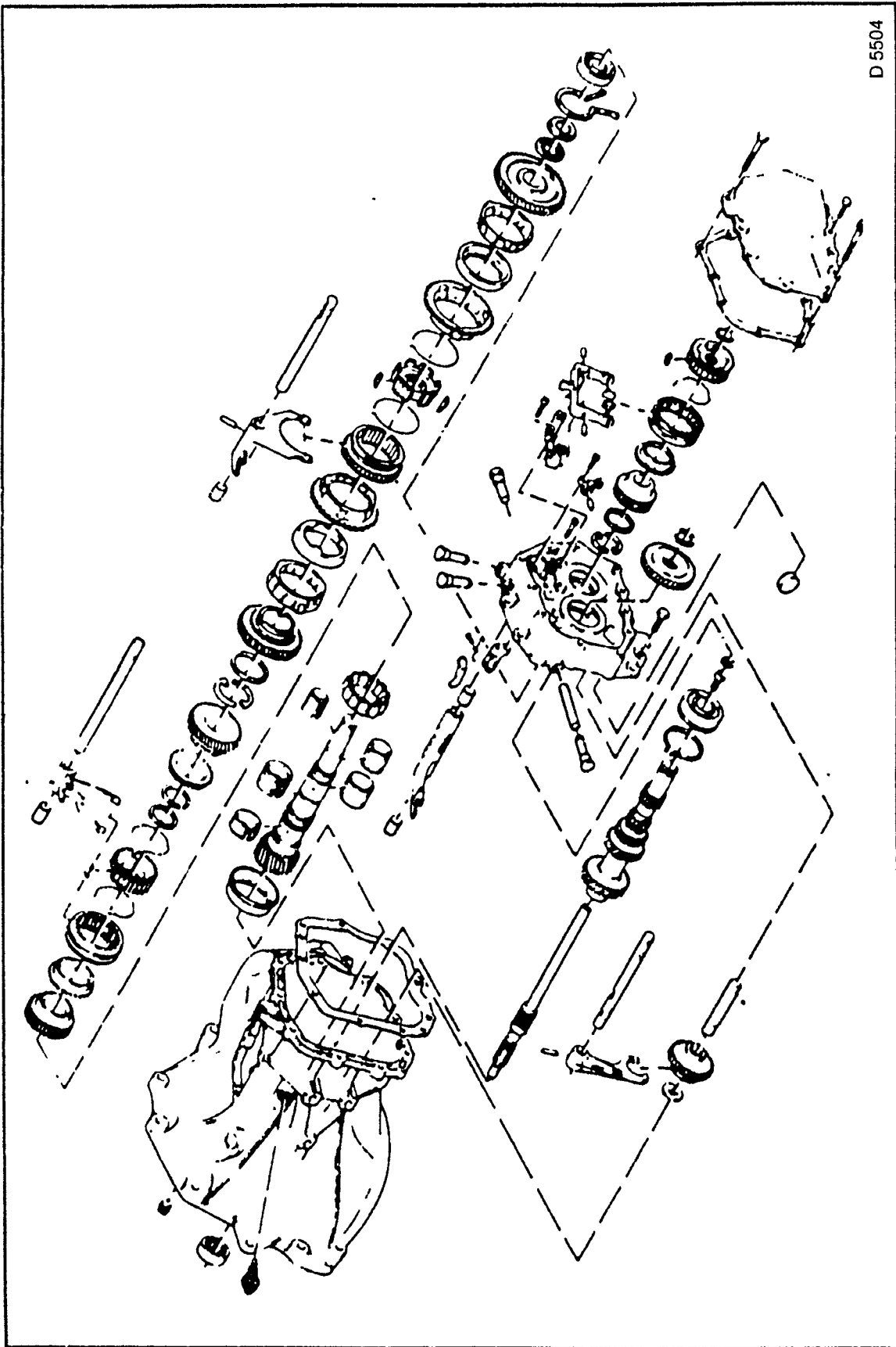
Fig. 3 — Manual Transmission F 16/5



D 0981

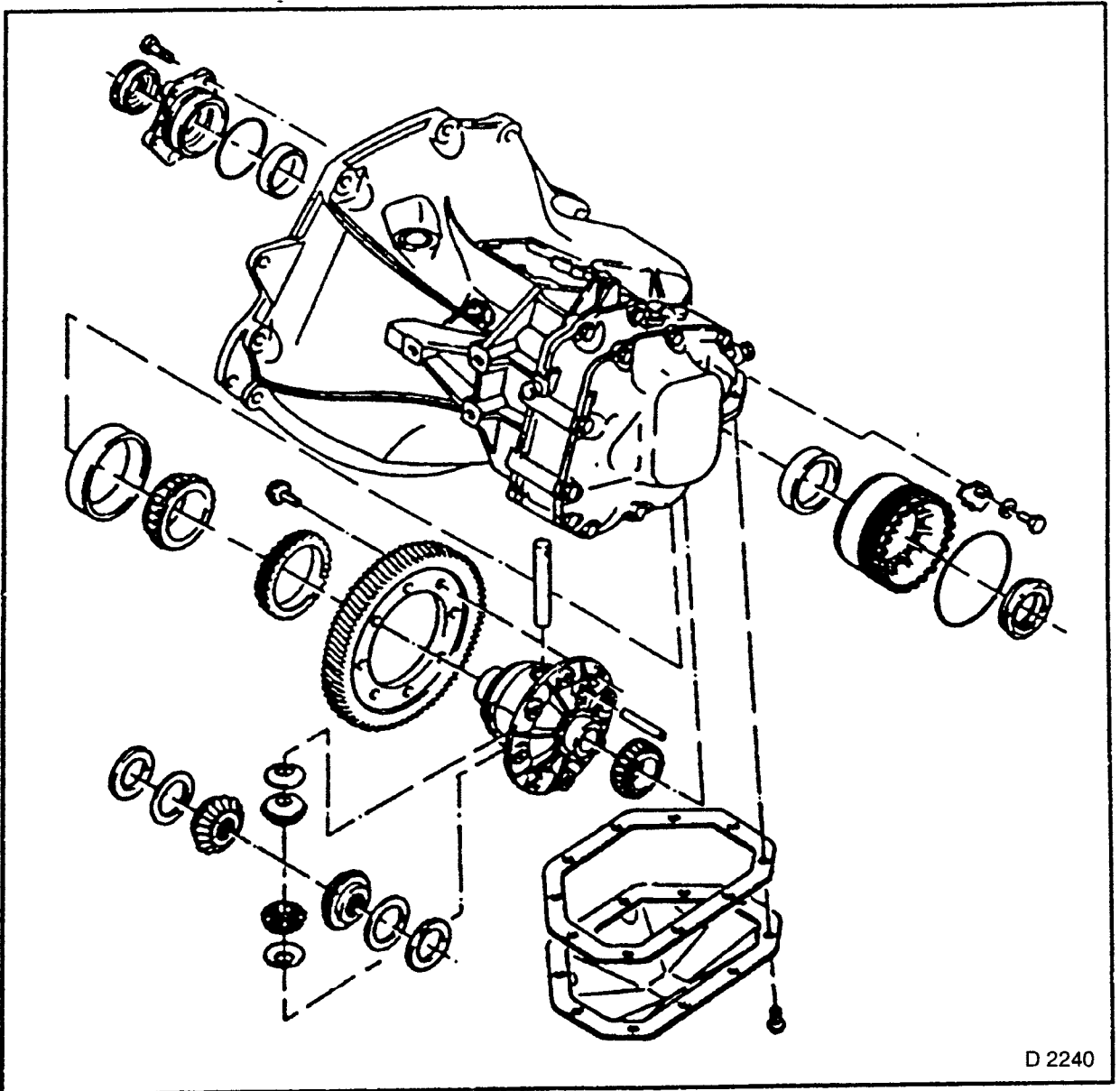
Fig. 4 — Differential F 16





D 5504

Fig 5 — Manual Transmission F 20



D 2240

Fig. 6 — Differential F 20

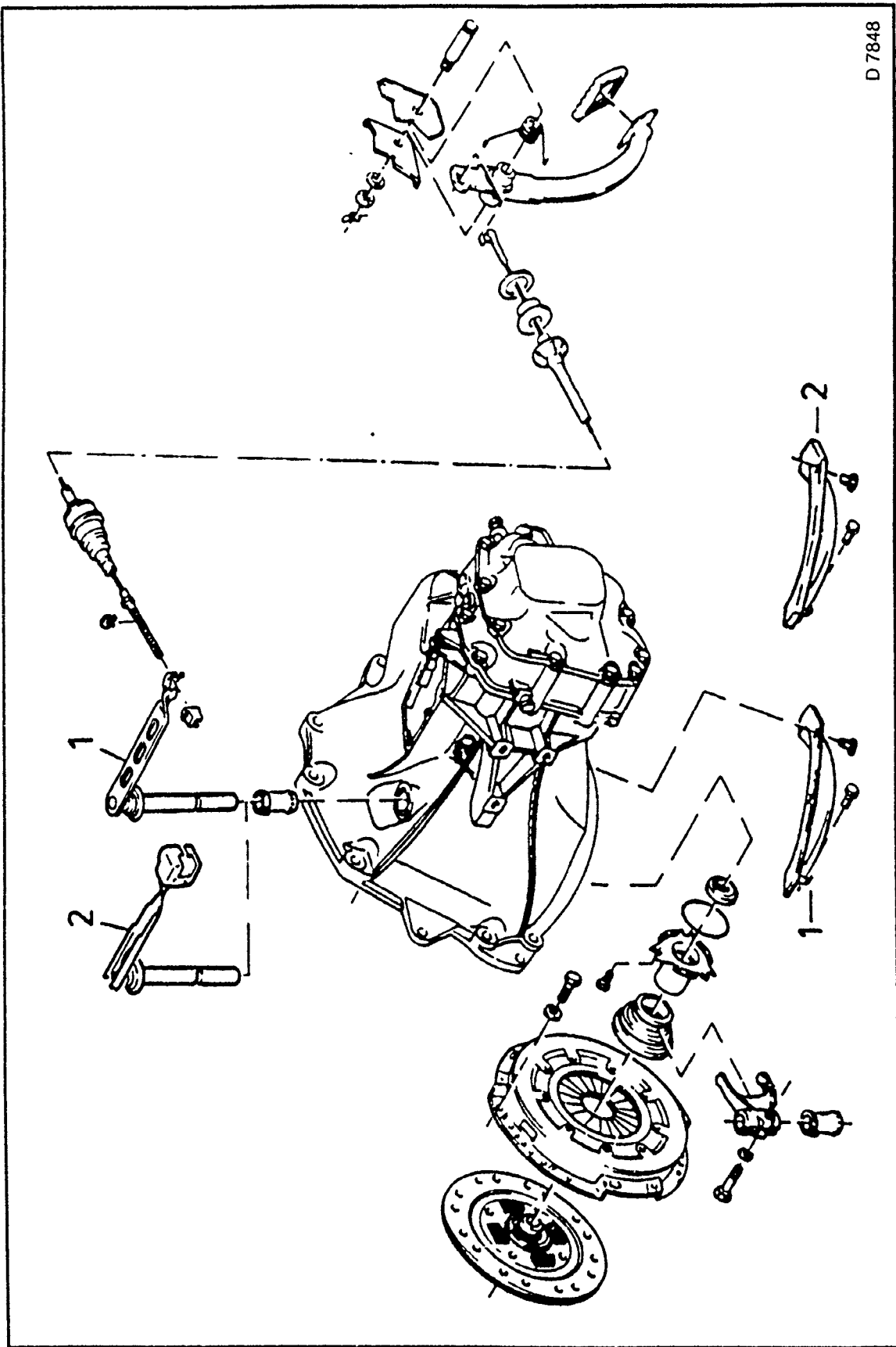


Fig 7 — Clutch Assembly  
Version 1 F 10, F 13, F 16 Manual Transmission  
Version 2 F 20 Manual Transmission

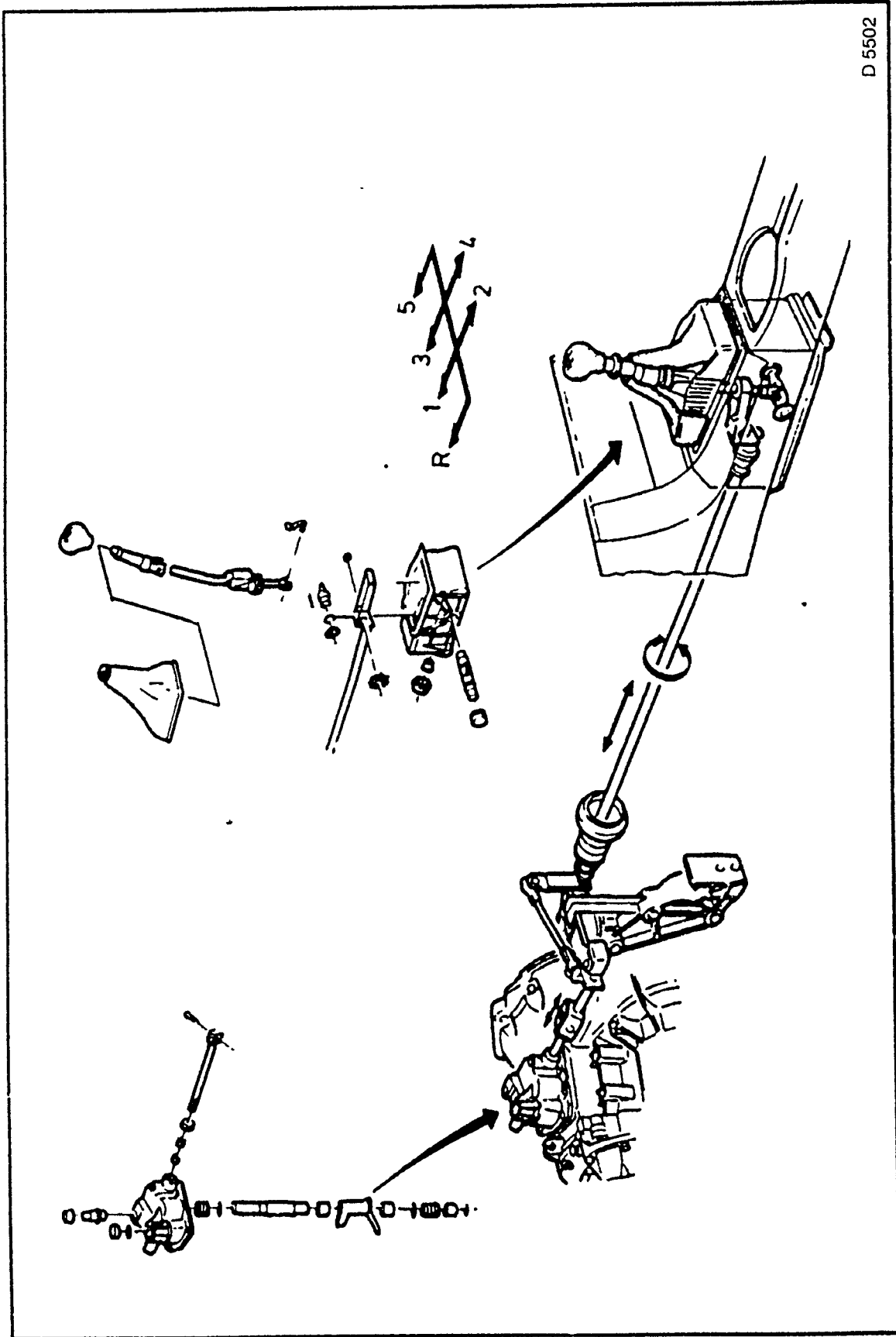


Fig 8 — Transmission Shift Linkage

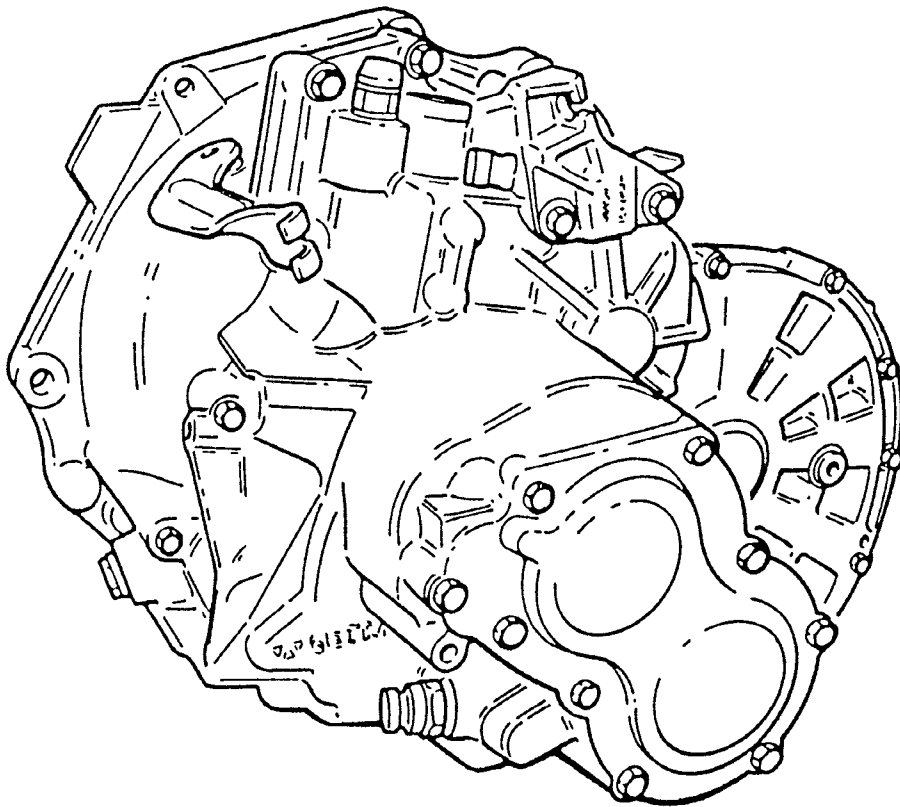
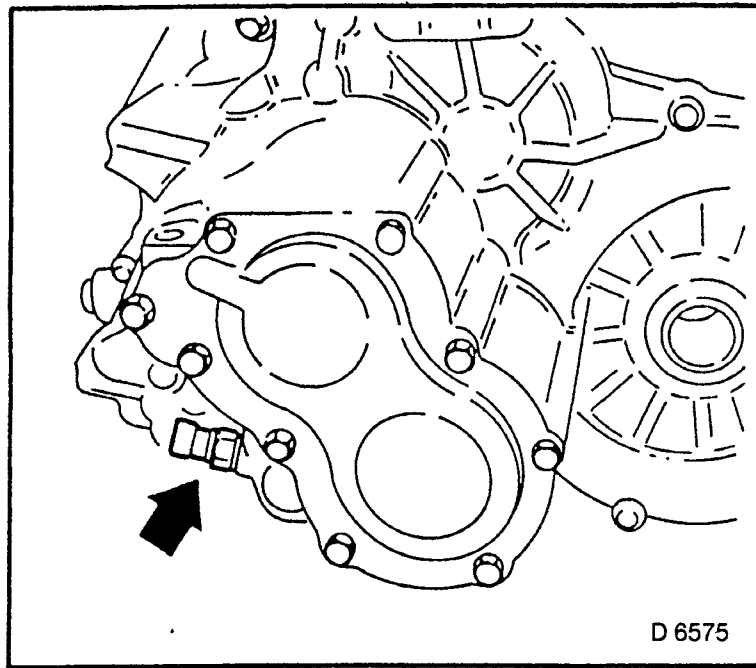


Fig. 9 — F 28 Manual Transmission

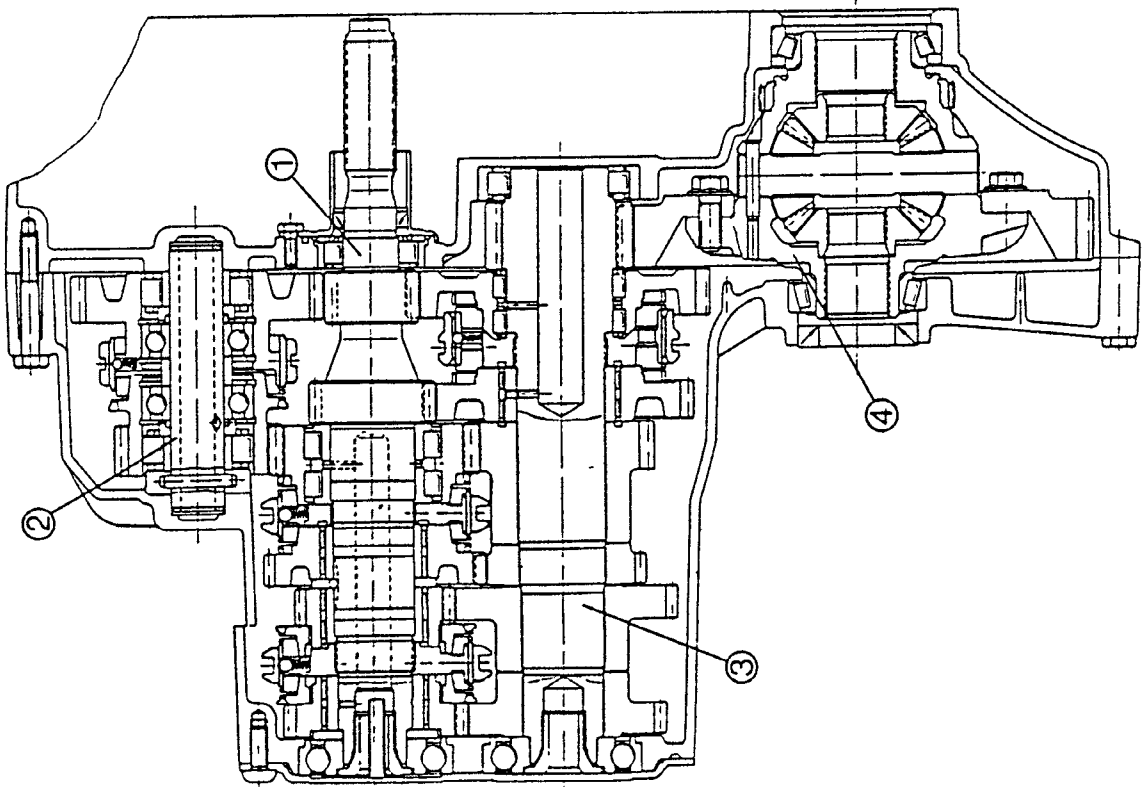
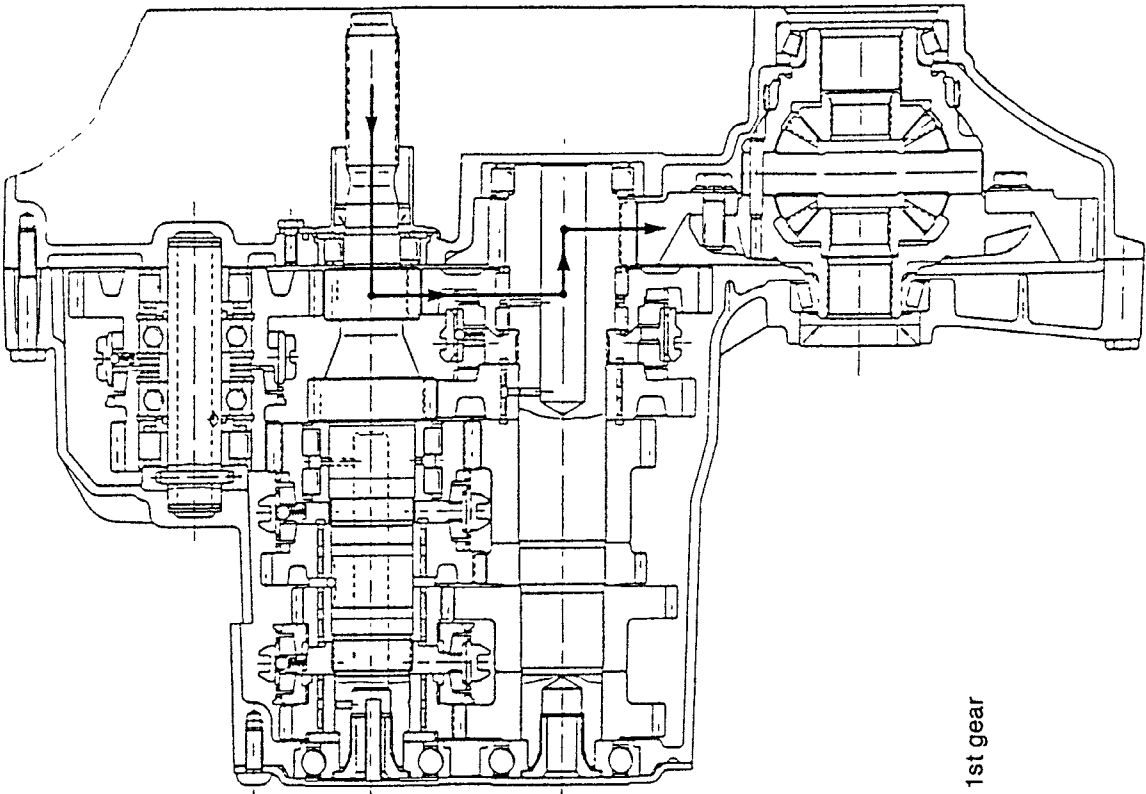


Fig 9A — F 28

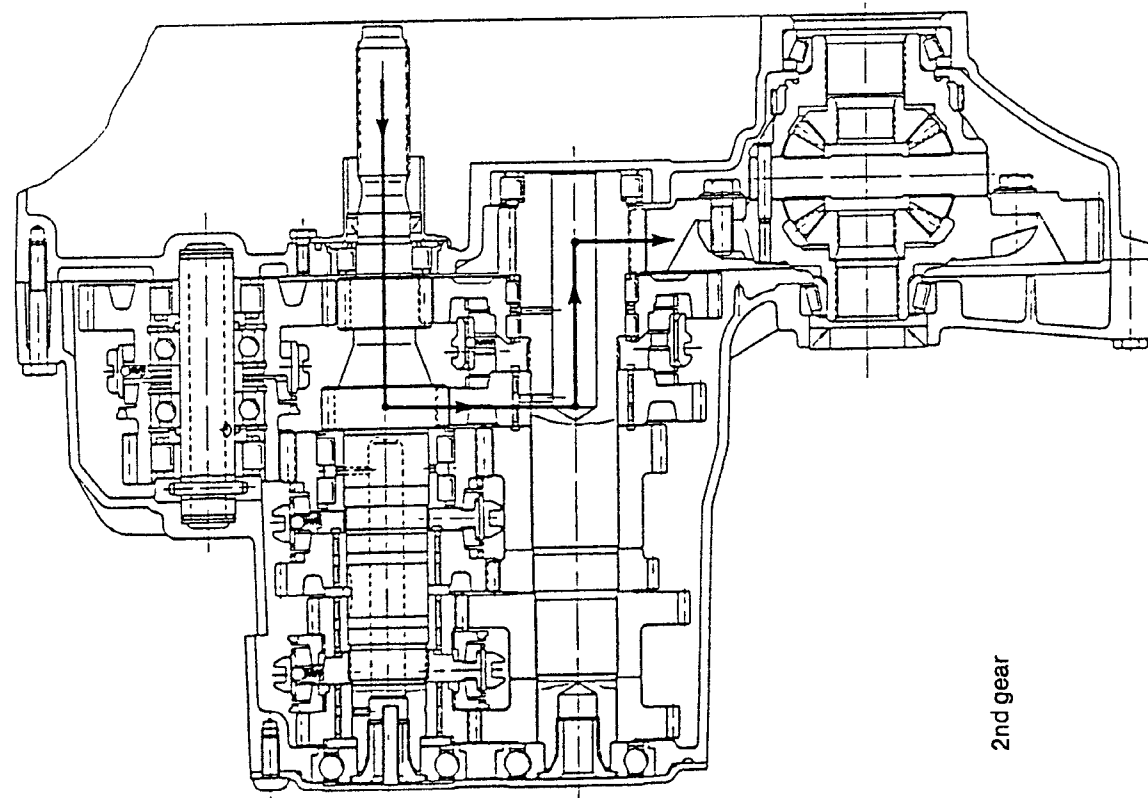
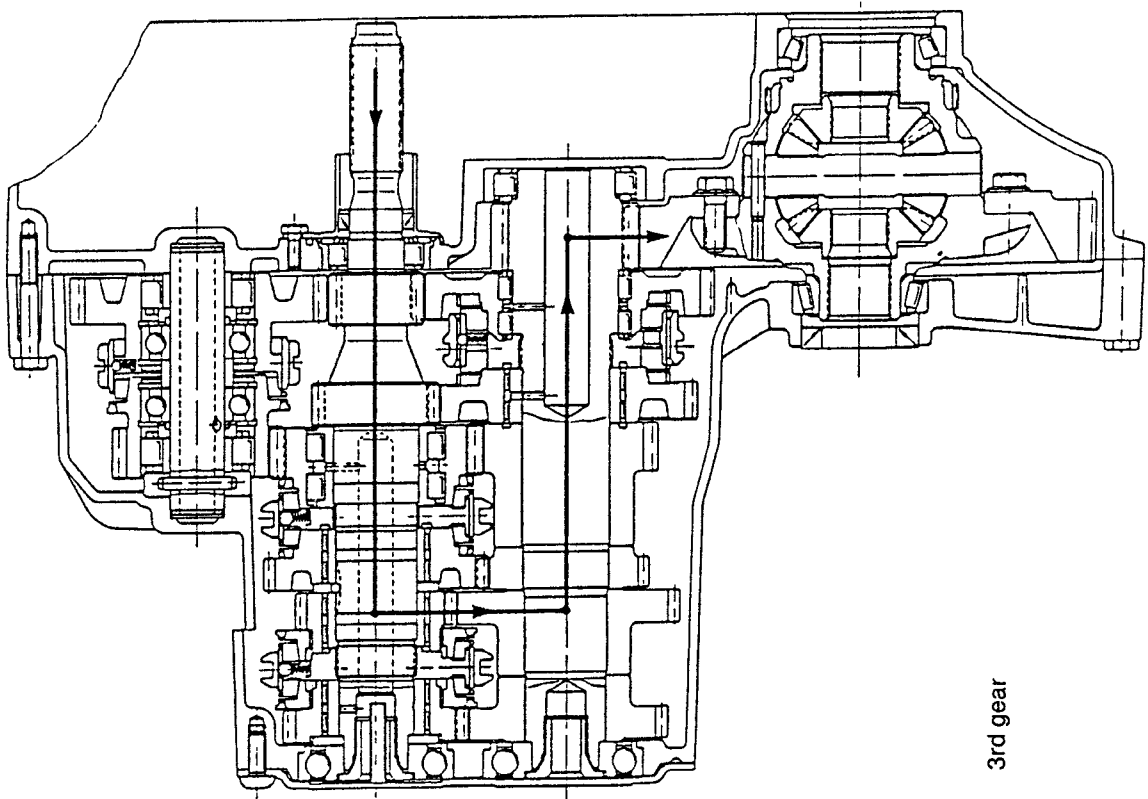
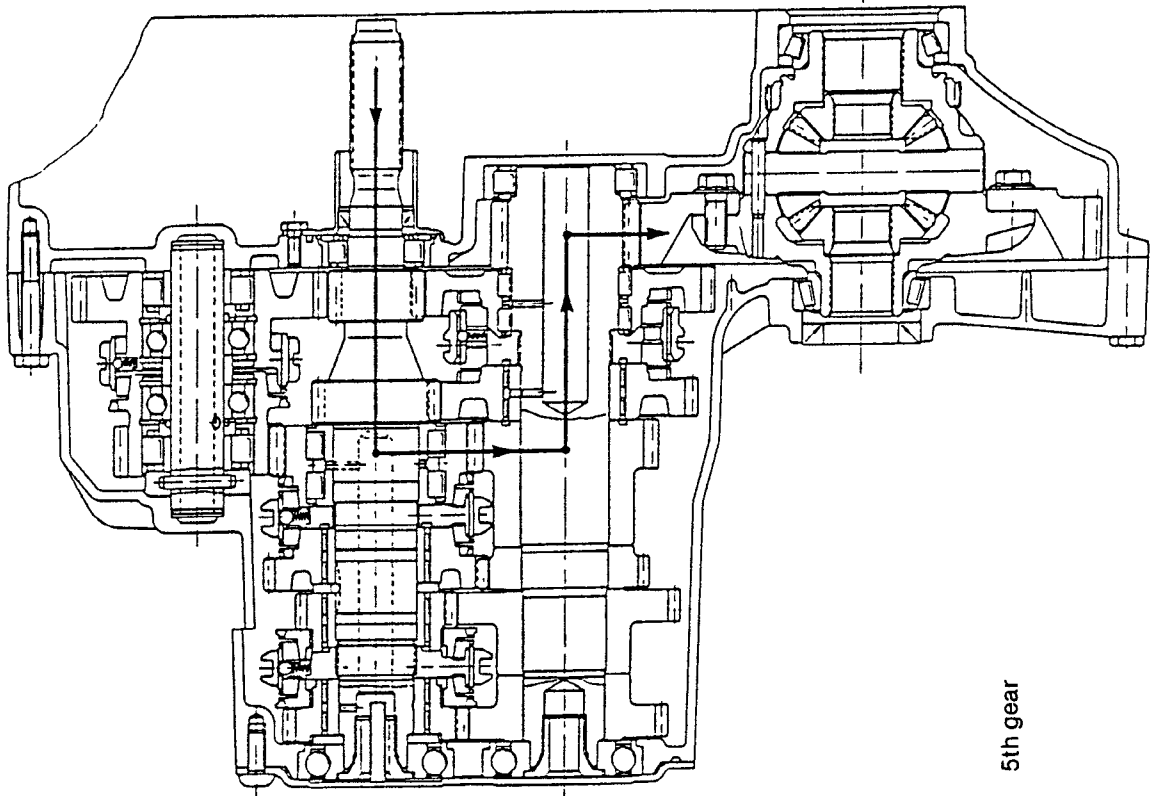
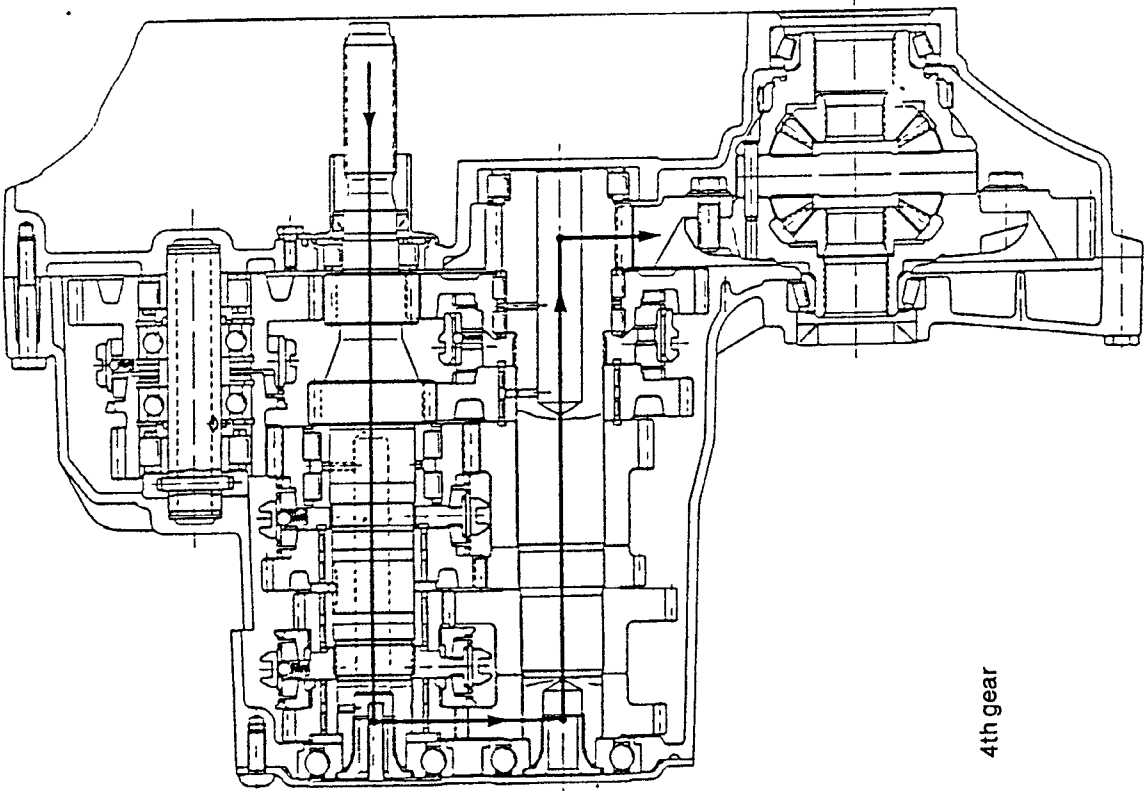


Fig 9B — F 28



5th gear



4th gear

Fig 9C — F 28



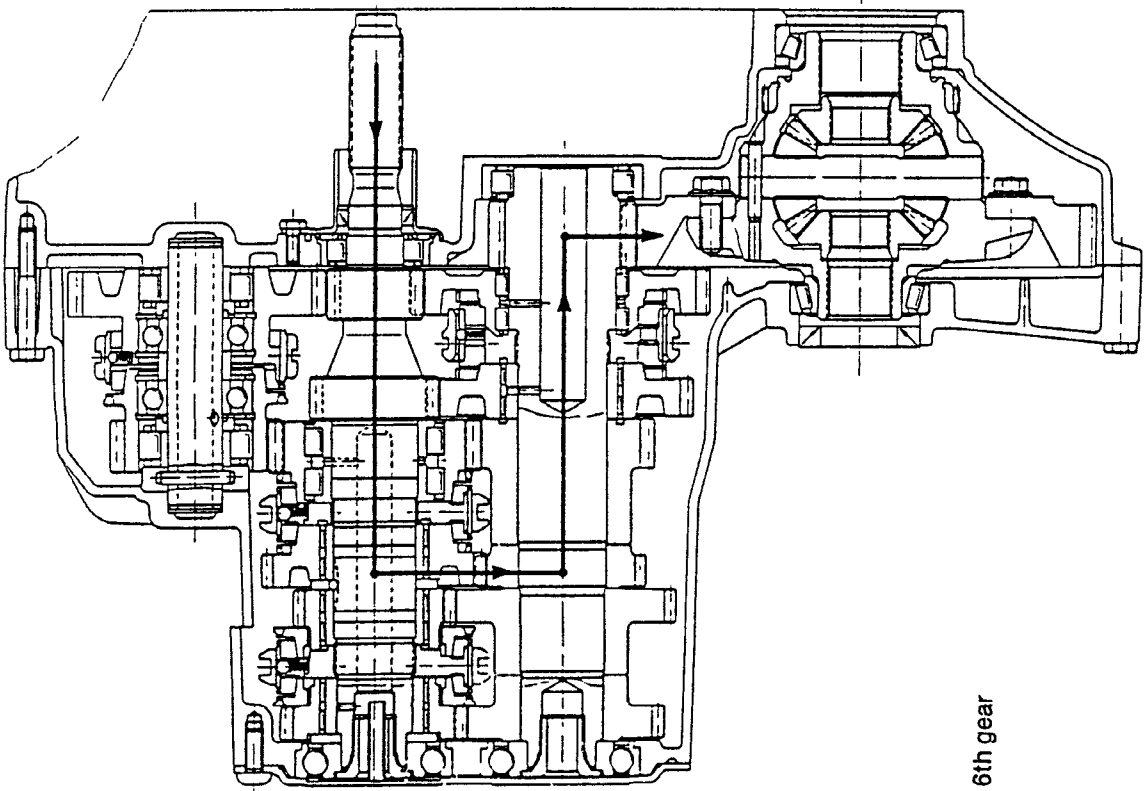
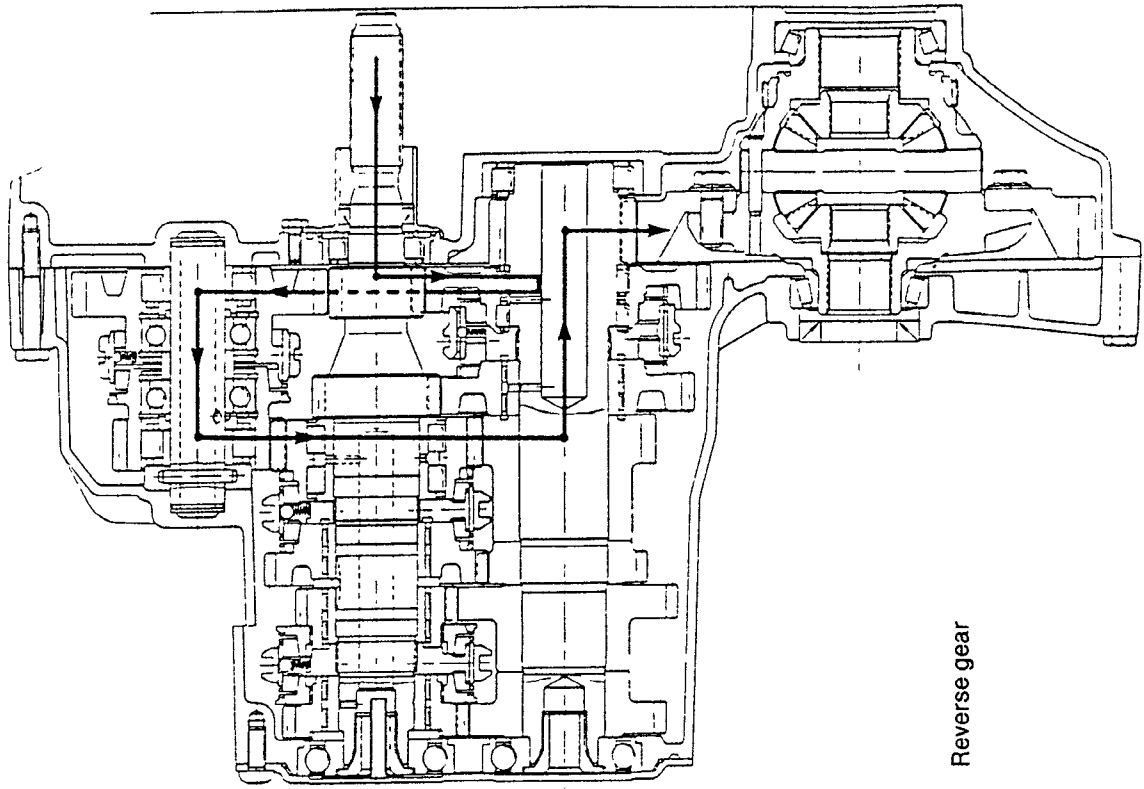


Fig. 9D — F 28

## MANUAL TRANSMISSION AND DIFFERENTIAL

Six transmissions are available ex works for the ASTRA-F. The identification F 10, F 13, F 16 or F 20, F 28, AF 20 is embossed on the upper side of the housing during the casting process.

F 10/4, 14NV (Astra/Kadett)

F 13/5: 14 NV Kadett, C 16 NZ, C 16 SE

F 16/5: 1800SE, 2,0 SEH

F 20/5: on C 20 XE LN (DOHC engine)

AF 20/4 1800 SE

F28/6 2,0 LET (DOHC)

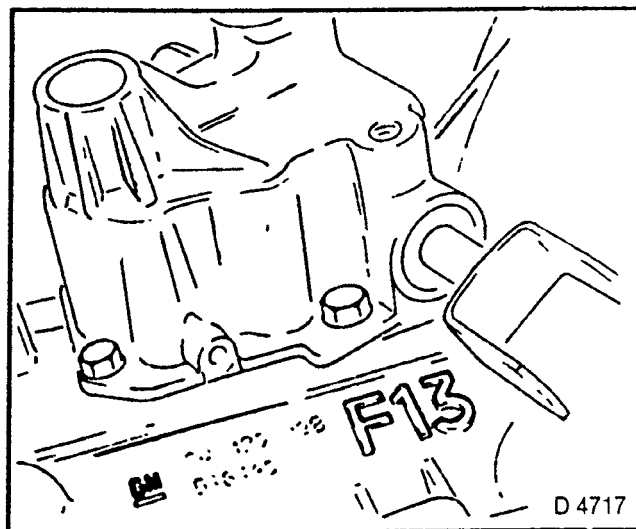


Fig. 10

### TRANSMISSION IDENTIFICATION

The transmission number can be read off from the combination of numbers and letters on the end shield cover.

Example: "A 126 1 2 W 372..."

A (1) = Manufacturing plant (not for F 16)

126 (2) = Day of year

1 (3) = Last digit of year

2 (4) = Works shift; 1 = early shift,  
2 = late shift

W (6) = Transmission code/high ratio (not for F 20)

C (6) = Transmission code/low ratio

372 (7) = Axle ratio

.. (5) = Space for numbers or letters for special purposes

The identification may also consist of two lines. If the end shield cover is replaced, the identification must be copied onto the new cover.

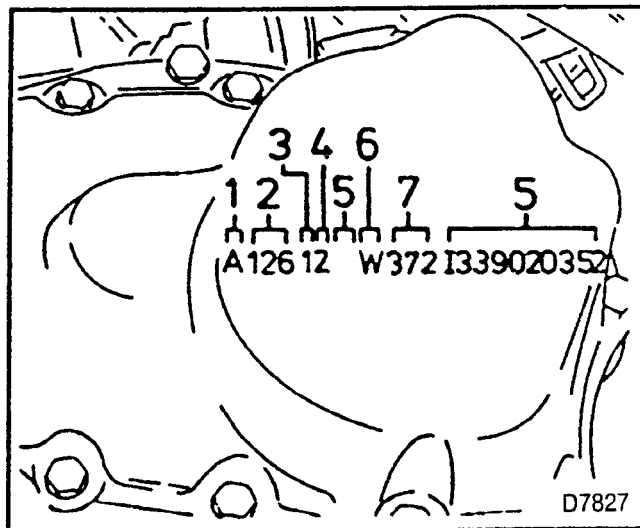


Fig. 10A

# CHECKING AND ADJUSTING OPERATIONS

## Transmission Fluid Level — Check

### REMOVE, DISCONNECT

1. Engine compartment cover  
 F 10, F 13, F 28: checking aperture rear left.  
 F 16, F 20: checking aperture rear right.

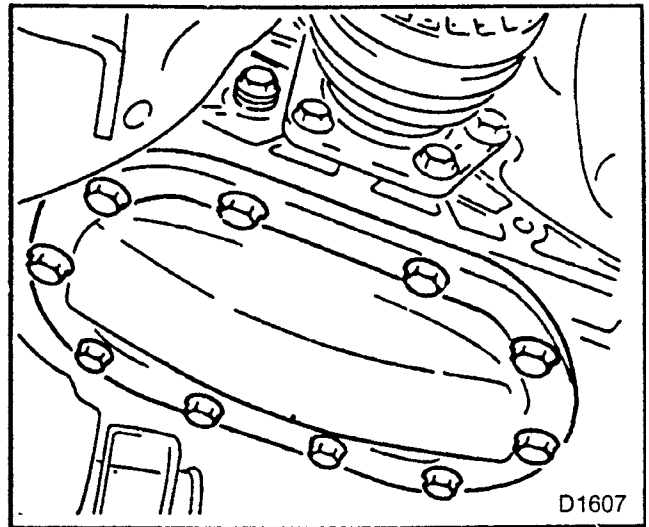


Fig. 11

Fill through opening for ventilation screw in shifting cover.

**MANUAL TRANSMISSION — F28/6:**  
 Filling through aperture for bleeder screw.

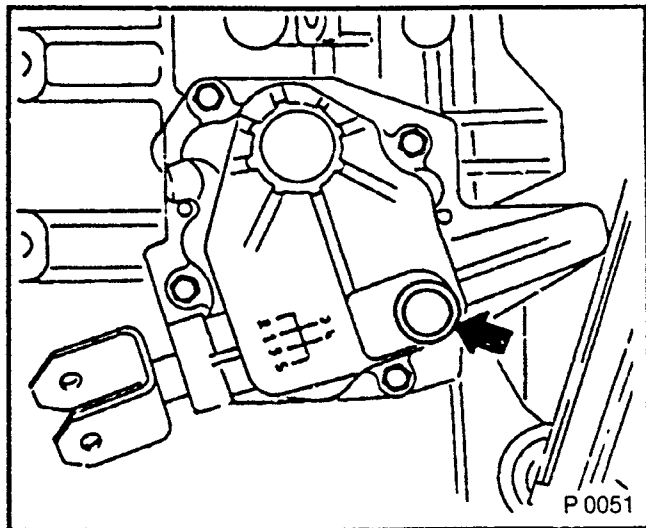


Fig. 12

To check fluid level, prepare tool (e.g. from welding wire) according to illustration on right.

|             | Fluid level up to lower edge of checking aperture: (factory provided) | Filling quantity after repair: |
|-------------|---|--------------------------------|
| F 10, F 13: | — 20 mm   | 1,6 litres                     |
| F 16, F 20: | — 0 mm  | 1,9 litres                     |
| F 28:       | — 0 mm  | 1,8 litres                     |

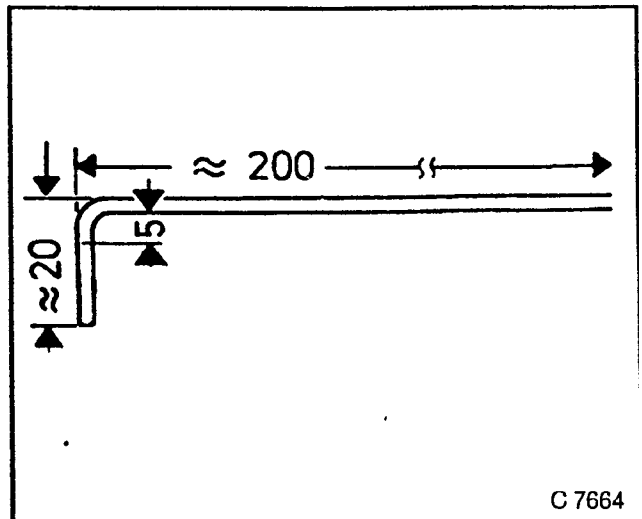


Fig. 13

When oil is service filled, it can be topped up until it flows out of the checking aperture.

On all manual transmissions, use Transmission Fluid B0400075.

## INSTALL, CONNECT

1. Engine compartment cover

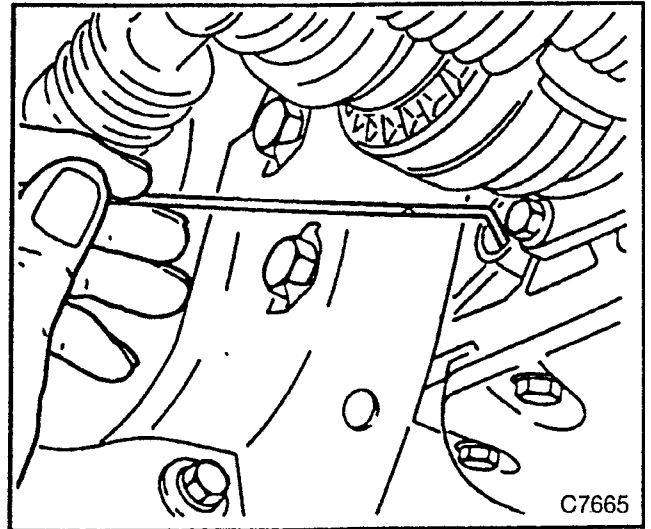


Fig 14

## Transmission Shift Linkage — Adjust

Put manual shift lever in neutral

### REMOVE, DISCONNECT

1. Shift lever cover from shift tunnel
2. Turn up rubber cap of manual shift lever.
3. Loosen screw for shift rod clamp (arrow).
4. Remove plug for adjusting bore from switching cover.

### ADJUST

1. Turn shift rod to left.
2. Insert KM-527 or KM-527-A up to stop in adjustment bore hole.
3. Transmission shift linkage on vehicles with F 28/6 manual transmission.

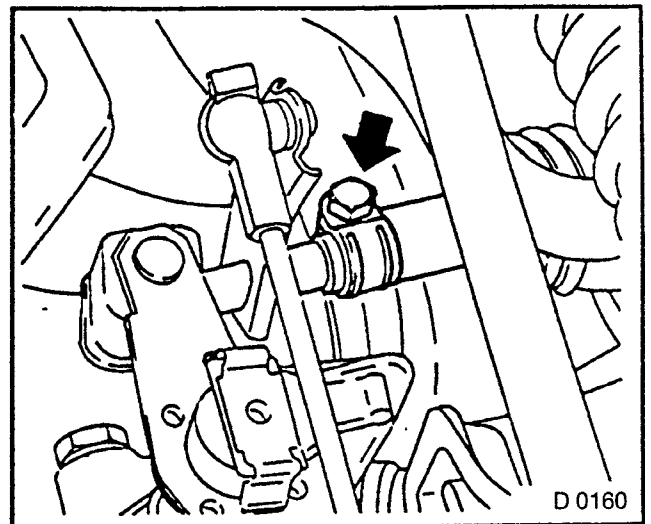


Fig 15

### NOTE:

If KM-527 (1) is used, the chamfer on the short leg must be ground down by approximately 3 mm.

KM-527-A (2) is already modified accordingly.

### INSPECT

1. Remove KM-527 or KM-527-A and close bore with new plug.

### INSTALL, CONNECT

1. Shift lever cover on shift tunnel.

### INSPECT

All transmission gears should be easy to engage with vehicle at rest, engine running and clutch disengaged.

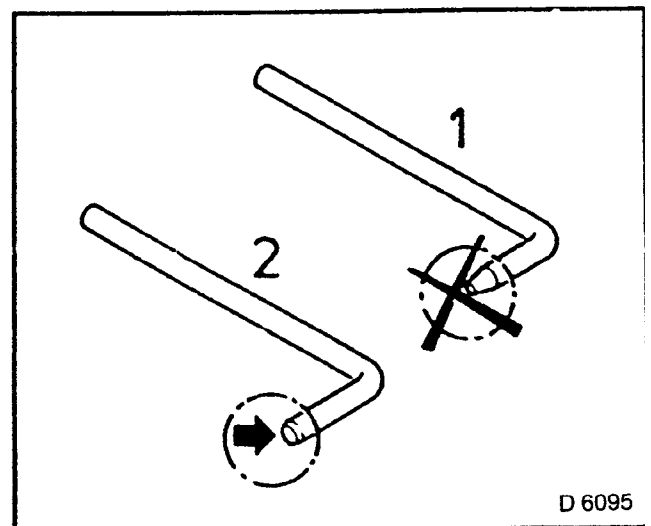


Fig. 16

## OPERATIONS ON TRANSMISSION SHIFT LINKAGE

### Manual Shift Lever — Remove and Install

#### MANUAL SHIFT LEVER IN NEUTRAL

#### REMOVE, DISCONNECT

1. Shift lever cover from shift tunnel.
2. Turn up rubber cap
3. Remove manual shift lever.
4. Press clip from lever (1) and pull pin with clip from bearing (2).

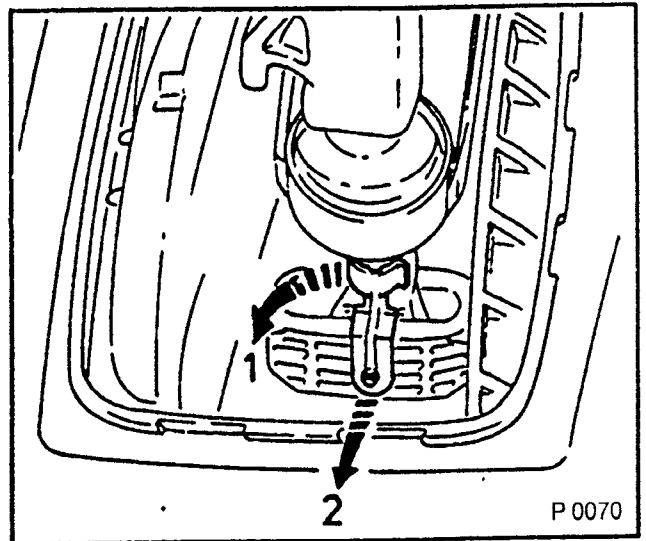


Fig. 17

#### INSTALL, CONNECT

1. Bolts in shift lever housing.
2. Secure with clamp.
3. Shift lever cover on shift tunnel.

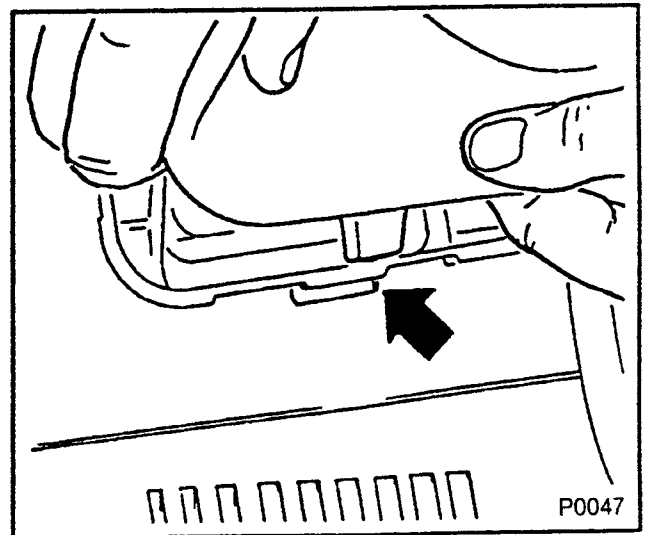


Fig. 18

### Rubber Cap for Manual Shift Lever — Remove and Install

#### REMOVE, DISCONNECT

#### MANUAL SHIFT LEVER

1. Knock off shift lever knob from shift lever, when replacing, saw off.  
On shift lever knob with leather covering: Clamp shift lever and place open ended wrench under metal inset of shift lever knob.
2. Rubber cap.
3. Replace O-ring on shift lever.

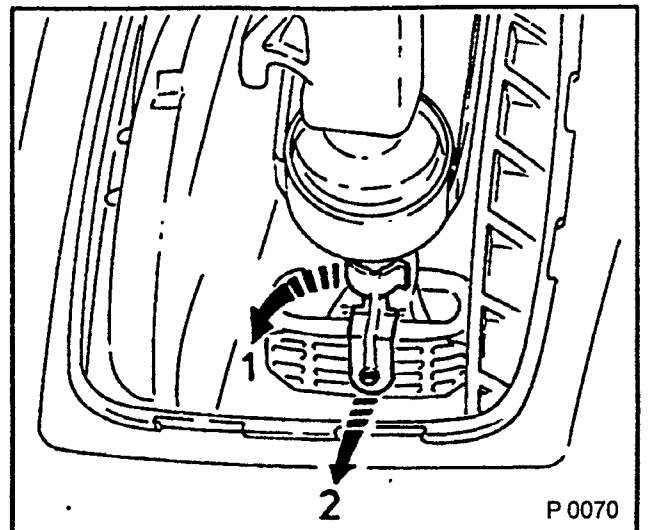


Fig. 19

## INSTALL, CONNECT

1. New rubber cap, pull on as far as offset.
2. Apply liquid soap to reverse gear pawl.
3. New shift lever knob on shift lever.

On plastic shift lever knob:

Heat knob to approximately 80°C/176°F  
(water bath, suitable temperature gauge)

On shift lever knob with leather covering:

Heat inset of shift lever knob with industrial hot air blower.

## Shift Linkage — Remove and Install

### REMOVE, DISCONNECT

Manual shift lever.

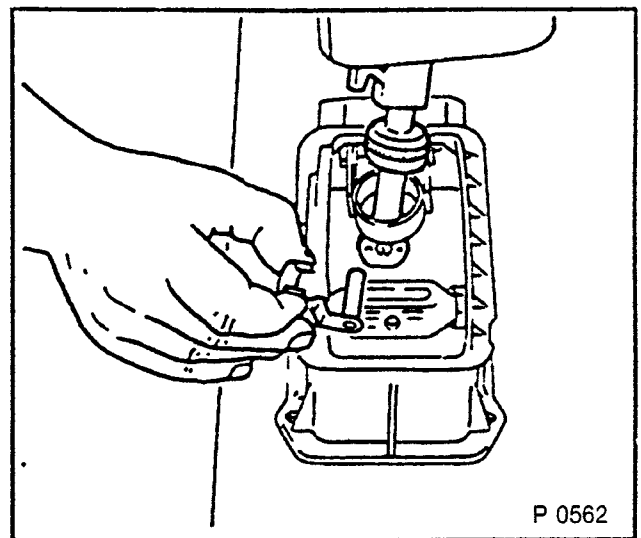


Fig. 20

1. Loosen bolt for shift rod clamp (arrow)
2. Press shift lever off from knurled bolts.

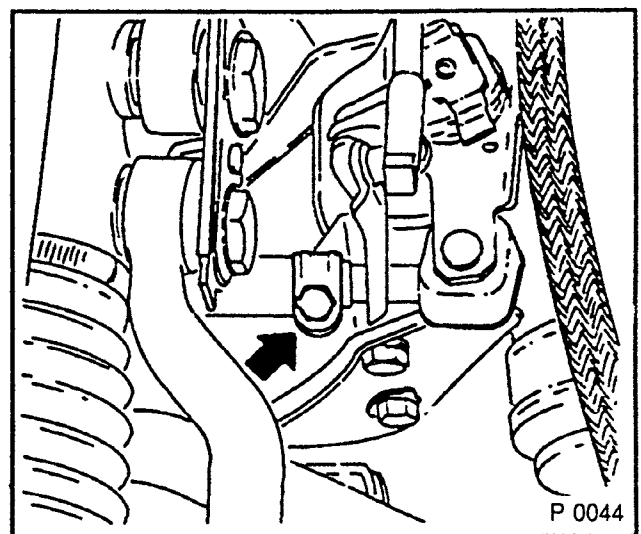


Fig. 21

**REMOVE, DISCONNECT**

1. Shift housing with shift linkage from underbody.

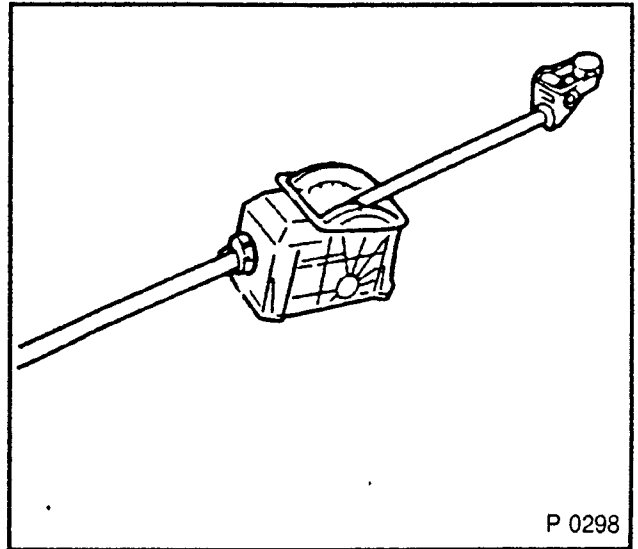


Fig. 22

2. Shift linkage from bearing bushing.
3. Bushing with bearing bushing from shift housing.

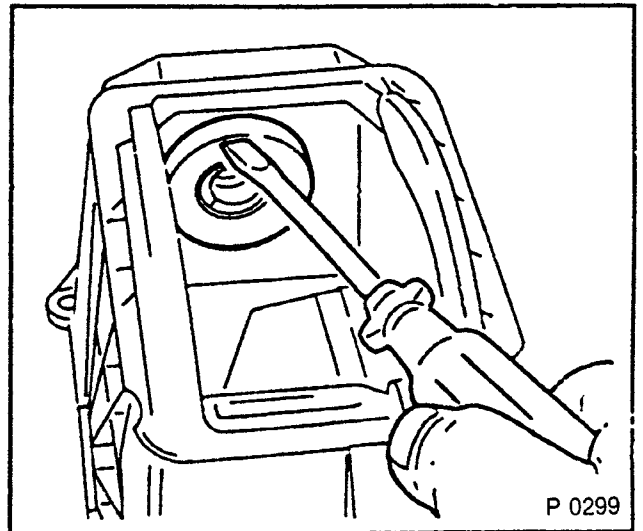


Fig. 23

**REMOVE, DISCONNECT**

1. Bearing bushing from bushing.
2. Replace bushing.

**INSTALL, CONNECT**

1. Press new bearing bushing (A) in bushing (B).
2. Press bearing ring into shift housing from inside.
3. Fill inside grooves of bushing with Silicon Grease (B0400571).
4. Shift linkage in bearing bushing.

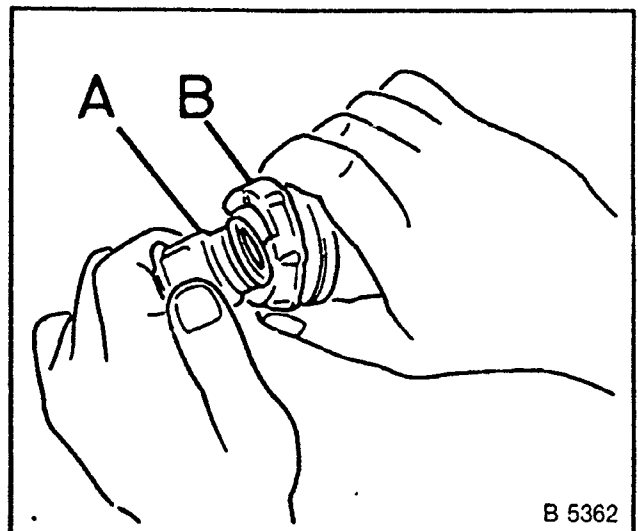


Fig. 24

**TIGHTEN (TORQUE)**

1. Shift housing to underbody, 6 Nm.

**INSTALL, CONNECT**

1. Shift lever

**ADJUST**

1. Transmission shift linkage.

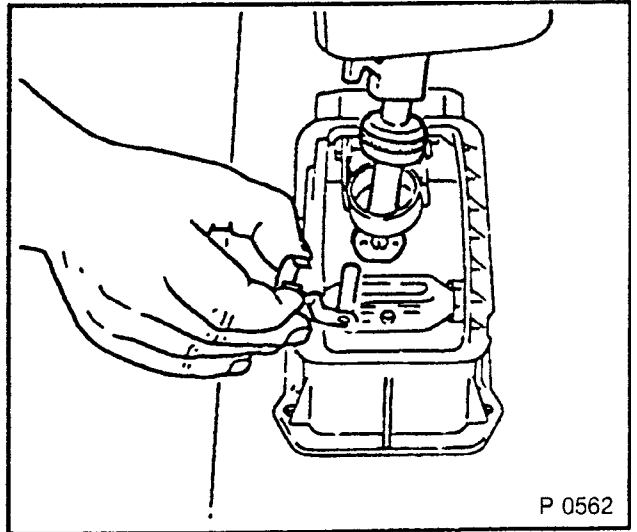


Fig. 25

**Folding Cover on Shift Linkage — Replace**

1. Loosen bolt for shift rod clamp (arrow).
2. Remove shift lever in 4th gear position — disconnect plug connection.

**REMOVE, DISCONNECT**

1. Clamp and folding cover from shift linkage/bulkhead.

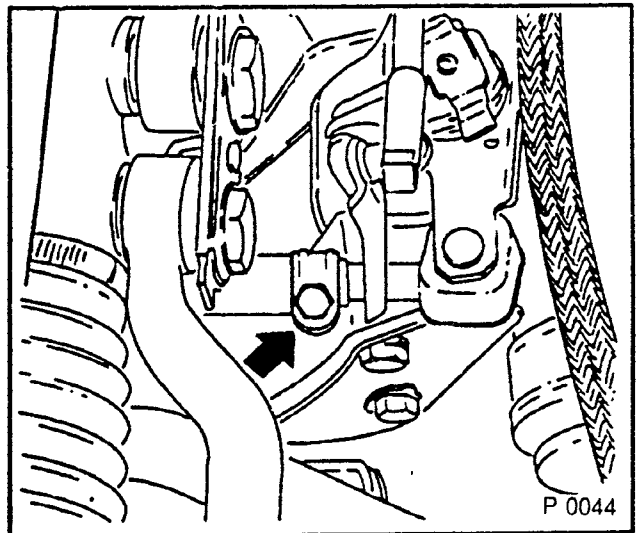


Fig. 26

**INSTALL, CONNECT**

1. New folding cover, must not lie twisted.

**ADJUST**

1. Transmission shift linkage.

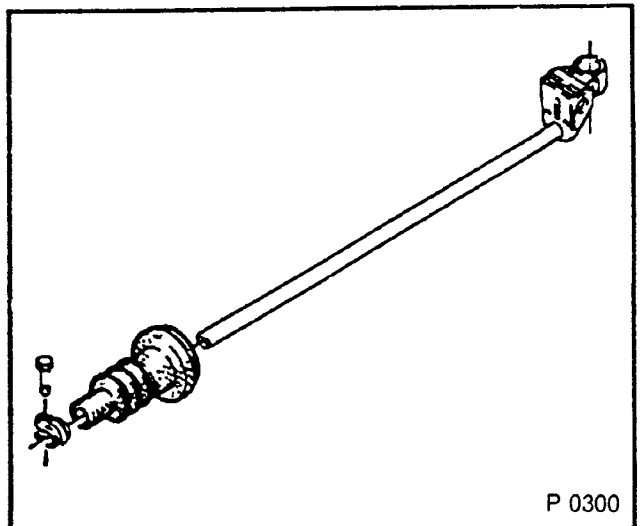


Fig. 27



## Shift Guide — Remove and Install Selector Rod — Replace

### REMOVE, DISCONNECT

1. Both ball sockets of selector rod (arrow) from ball pivot.
2. Press plastic clips outwards with screwdriver
3. Replace selector rod in assembly.

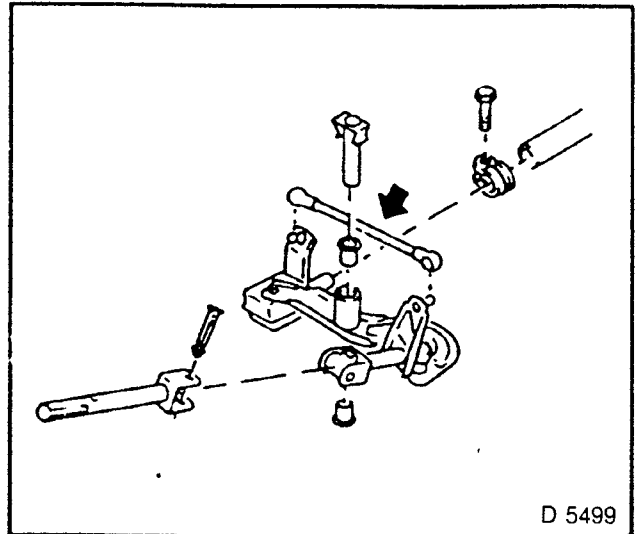


Fig. 28

## Shift Linkage Lever — Remove and Install

### REMOVE, DISCONNECT

1. Selector rod.
2. Press together retaining springs of hollow pin (1) and press out hollow pin (arrow).
3. Replace hollow pin after removal.

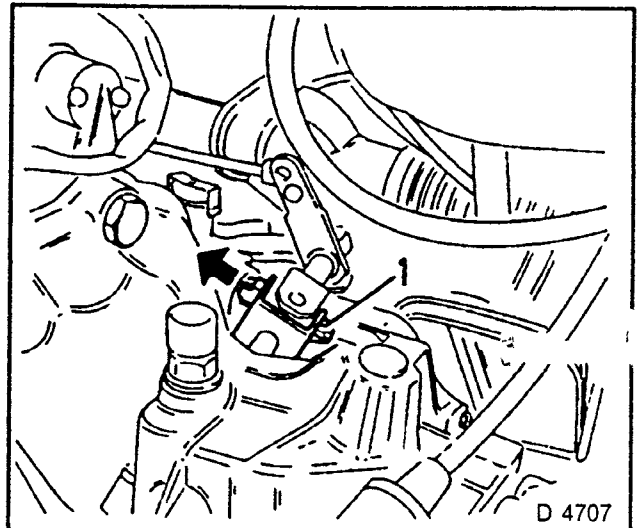


Fig. 29

4. Loosen bolt for shift rod clamp (arrow left).

### REMOVE, DISCONNECT

1. Pin with spring clamps (arrow right) from shift linkage lever bearing.
2. Shift linkage lever assembly from bracket for rear engine suspension.

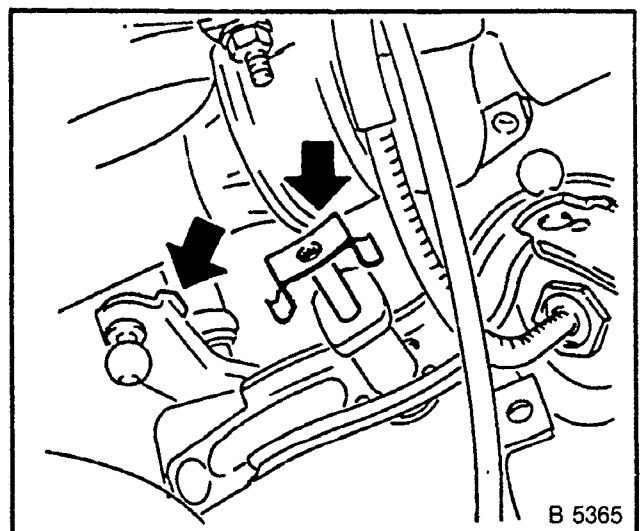


Fig. 30

- Both bushings of shift linkage lever bearing may be replaced. If necessary, replace joints at cardan joint.

**NOTE:**  
**DO NOT DISASSEMBLE SHIFT LINKAGE LEVER ANY FURTHER.**

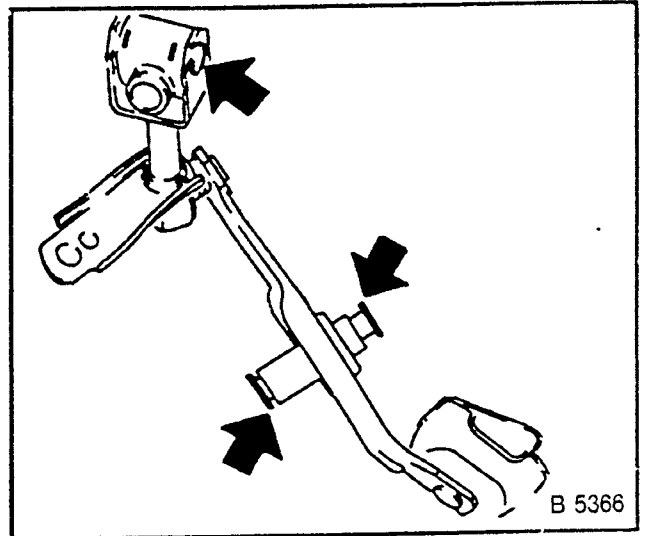


Fig. 31

## INSTALL, CONNECT

- Shift linkage lever assembly to transmission with pin.
  - Spring clamps catch.
  - Lubricate bearing bushings, Silicon Grease.
- 
- Knurled bolt of shift linkage lever in shift linkage.  
**DO NOT tighten linkage clamp.**
  - New hollow pin at cardan joint, engage expanding springs (1).
  - Lubricate pin, Silicon Grease.
  - Selector rod.

## ADJUST

- Transmission shift linkage.

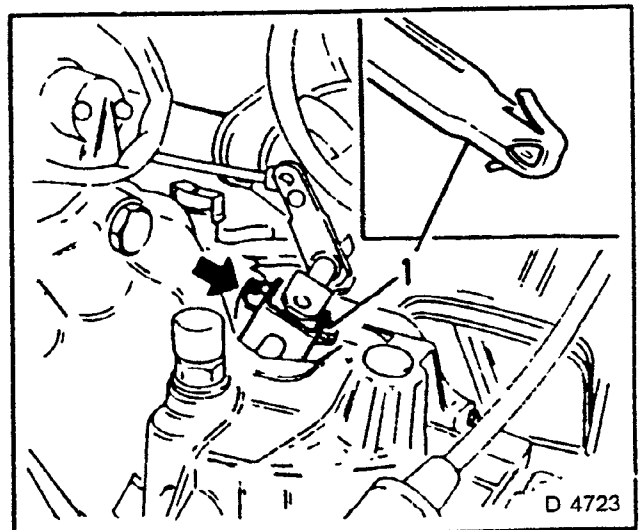


Fig. 32

## Shift Cover — Remove and Disassemble

TRANSMISSION INSTALLED:

### REMOVE, DISCONNECT

1. Press together retaining springs of hollow pin (1) and press out hollow pin (arrow).
2. Replace hollow pin after removal.

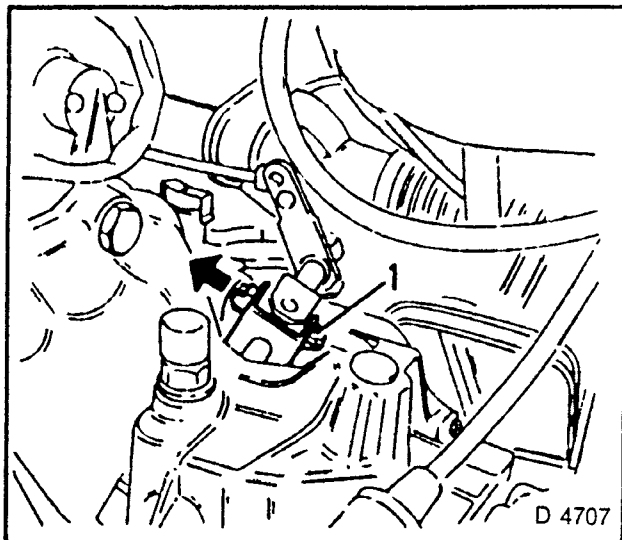


Fig 33

3. Closure bolt for transmission vent (arrow) from shift cover.
4. Remove transmission shift cover.
5. Pull out plug from adjusting bore and insert KM-527-A.
6. When using KM-527, grind down chamfer heel on short end by approximately 3 mm.

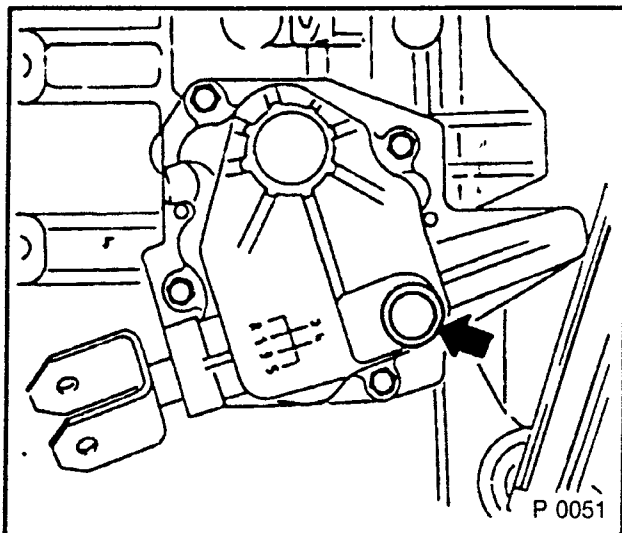


Fig 34

### INSTALL, CONNECT

1. Shift cover to KM-552 or KM-488.

### DISASSEMBLE

1. Retaining ring.
2. Bushing.
3. Pressure spring.
4. Intermediate shift lever.
5. Washer.
6. Spring from guide pin.

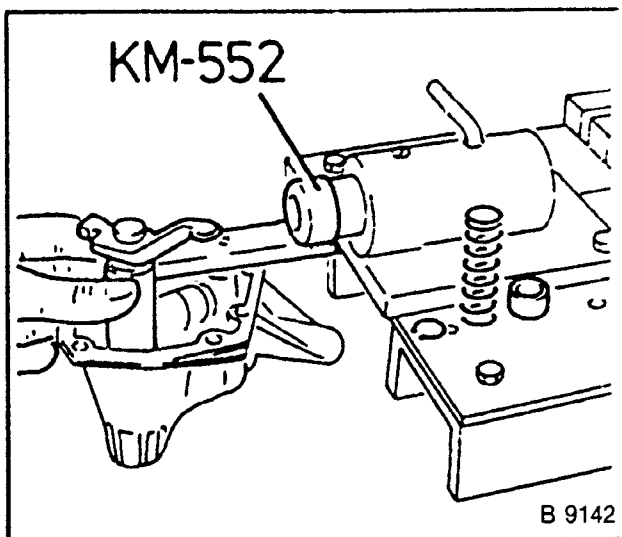


Fig. 35

## REMOVE, DISCONNECT

1. Tension pin (1) from shift finger (2) and shift rod (3) — using drift, note depression in cover.
  2. Shift rod.
- DO NOT** disassemble cover further.
3. Replacement available only as guide pin and cap assembly.

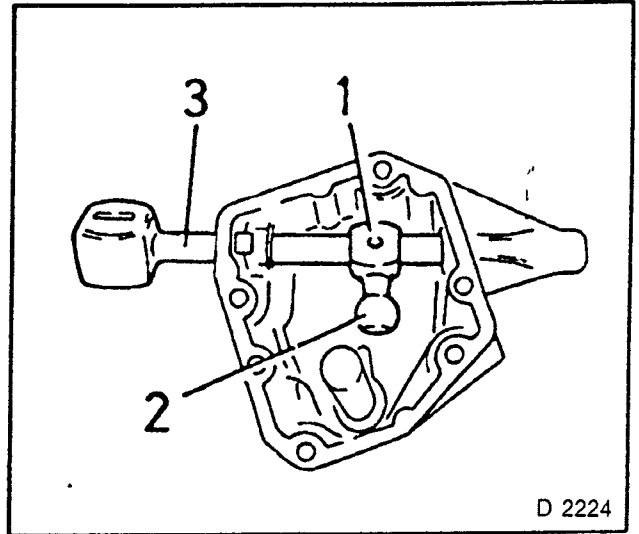


Fig 36

## Shift Cover — Assemble and Install

### REPLACE SEAL RING IN COVER

### INSTALL, CONNECT

1. Drive in new seal ring flush with suitable sleeve (arrow).
2. Lubricate seal lips with Grease.

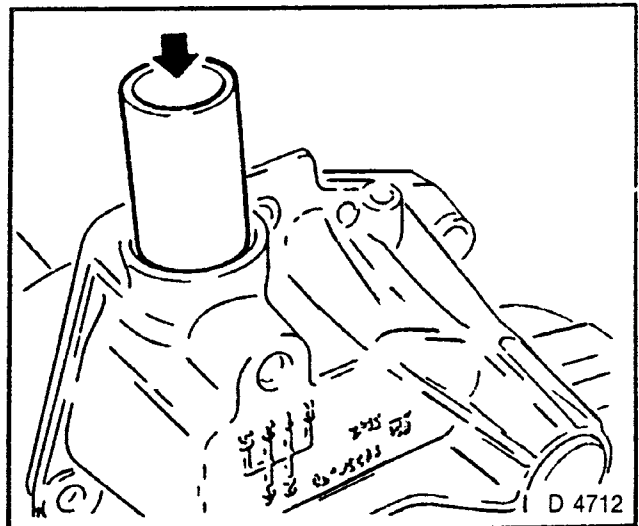


Fig 37

## ASSEMBLE

1. Install shift rod and shift finger in cover, KM-308.  
Allow new tension pin to protrude approximately 2 mm.
2. Install spring (1).
3. Washer (2).
4. Intermediate shift lever (3).
5. Washer (4).
6. Pressure spring (5).
7. Bushing (6) on guide pin.
8. Secure with new retaining ring.

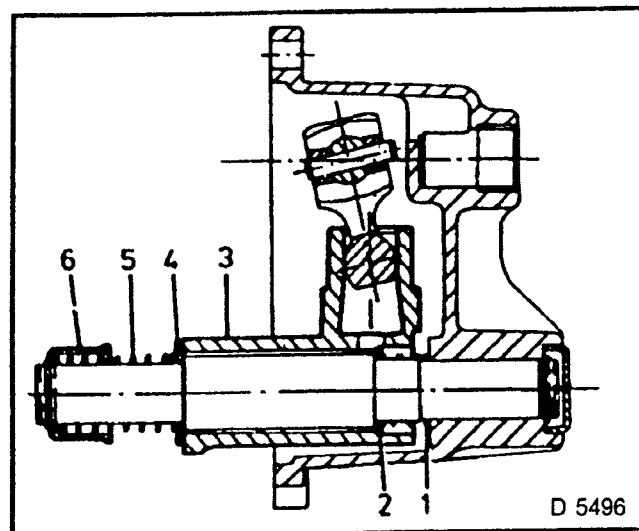


Fig. 38

**BEFORE INSTALLATION OF SHIFT COVER:****MEASURE**

1. Play (1) between dowel pin (2) and actuation of 3rd/4th gear shift rod with feeler gauge.
2. Play (1) should be approximately 0.5 mm.

**ADJUST**

If play is too large:

1. Drive dowel pin (2) into transmission housing with drift and measure play again.

If play is too small:

Correction of play is not required as the shift rod presses the dowel pin into the correct position.

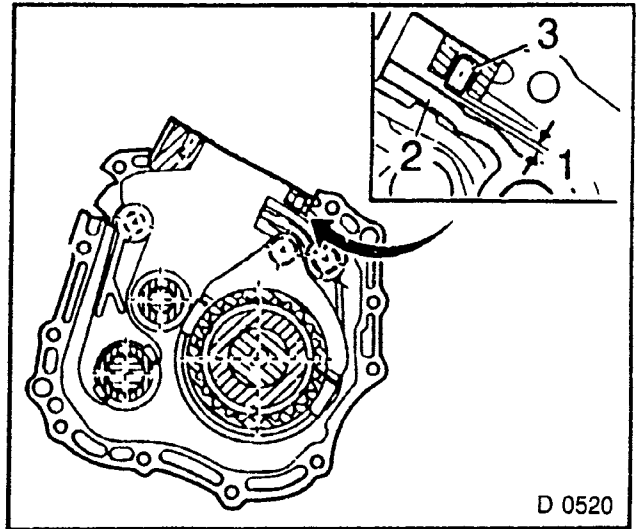


Fig. 39

**TIGHTEN (TORQUE)**

1. Place KM-527-A in adjusting bore.
2. Cement new gasket with Anti-friction Bearing Grease at housing. Transmission in neutral.
3. Place cover for shift at transmission and tighten — 15 Nm.
4. Remove KM-527-A.
5. Insert new plug in adjusting bore.

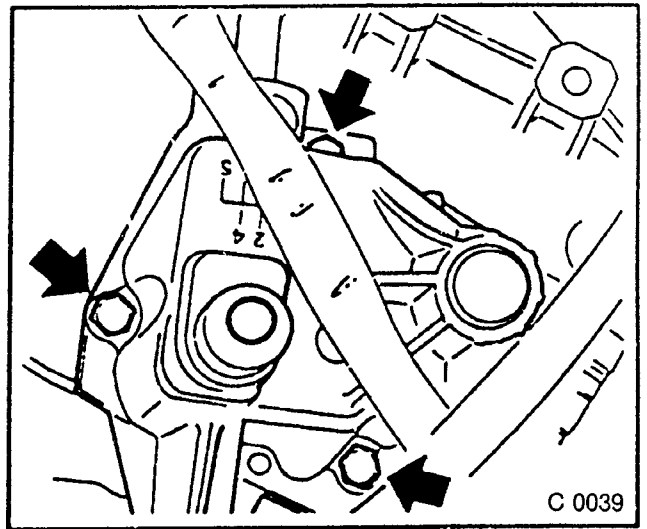


Fig. 40

**INSTALL, CONNECT**

1. Locking bolt for transmission ventilation.
2. Coat new hollow pin with Silicon Grease (B0400571).
3. New hollow pin (1) to cardan joint, expanding springs catch.

**INSPECT**

1. Transmission fluid level.

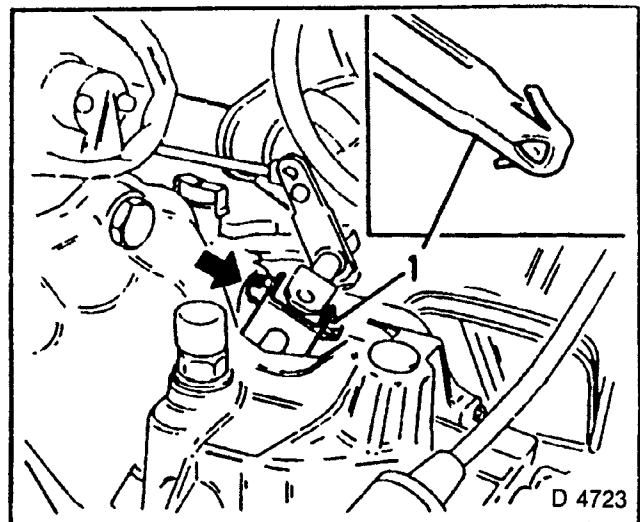


Fig. 41

## SEALING OPERATIONS ON INSTALLED TRANSMISSION

### Axle Shaft Seal Rings — Replace

#### REMOVE, DISCONNECT

- Both front wheels.
- Swivel joints from steering knuckles — KM-507-C  
If present: engine compartment cover.  
If present: stabilizer fastening from control arms — (see Section E).

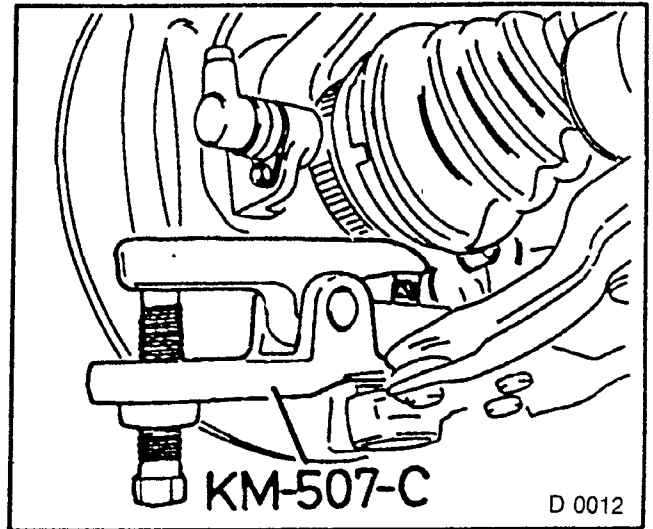


Fig. 42

#### REMOVE, DISCONNECT

Axle shafts from transmission.

|             | Left       | Right             |
|-------------|------------|-------------------|
| F 10, F 13  | KM-460-2-A | KM-460-2-A        |
| F 16, F 20* | KM-503-A   | KM-460-2-A        |
| F28         | KM-503-A   | Soft metal drift. |

Chamfered side of tool points towards transmission.

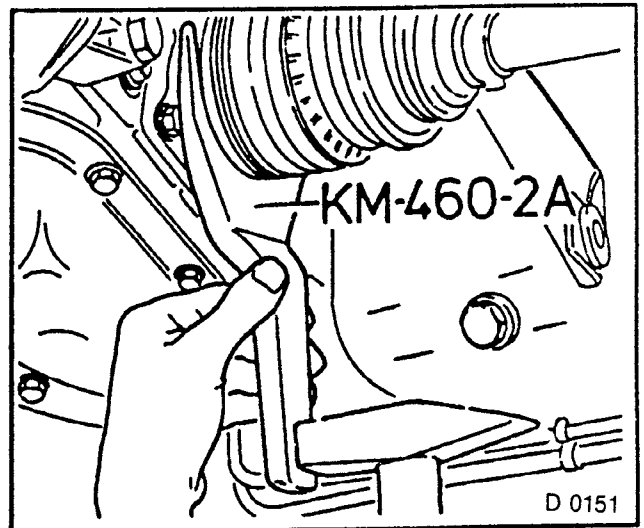


Fig. 43

#### NOTE:

With F 20 — left side:

- \* KM-503-A (1) at differential cover (2), do not support against tapered roller bearing adjusting nut (3).

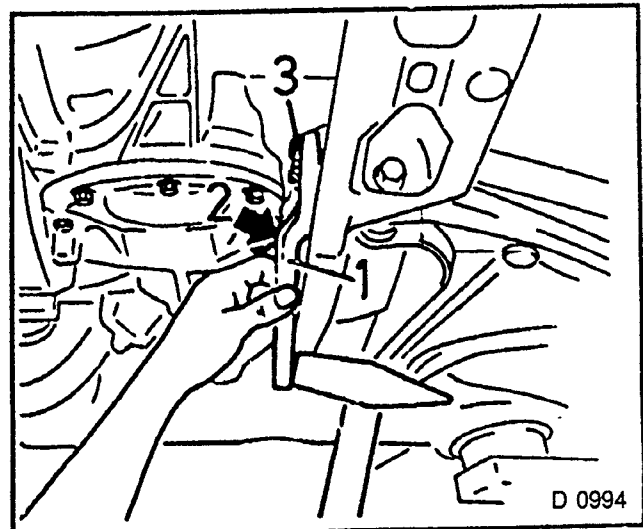


Fig. 44

**WARNING:**  
**FLUID ESCAPES. CLOSE OPENINGS.**  
**BIND UP AXLE SHAFTS.**

### REMOVE, DISCONNECT

1. Seal ring  
 F 16, F 20 transmission: from bearing ring/bearing flange.  
 F 10, F 13 transmission: from bearing ring/transmission housing — MKM-557 (1) for each.  
 F28/6 transmission — from transmission housing.

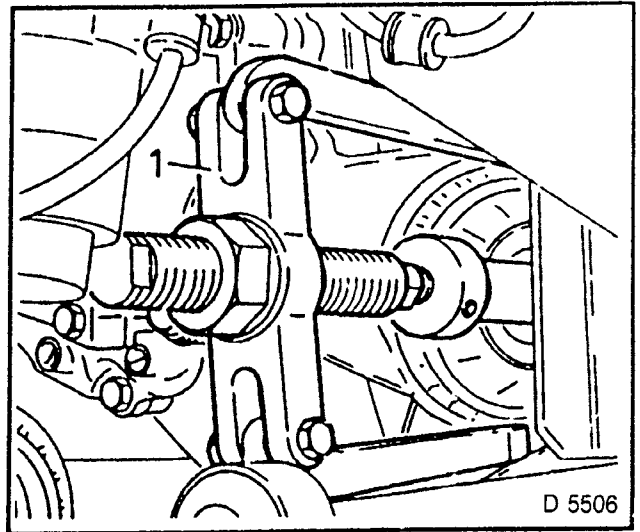


Fig. 45

### INSTALL, CONNECT

1. Seal rings  
 F 10, F 13 transmission: in transmission housing/bearing ring, KM-446  
 F 16, F 20 transmission: bearing flange/bearing ring, KM-519  
 F28 transmission — from transmission housing, KM-519.
2. Drive in seal rings flush.

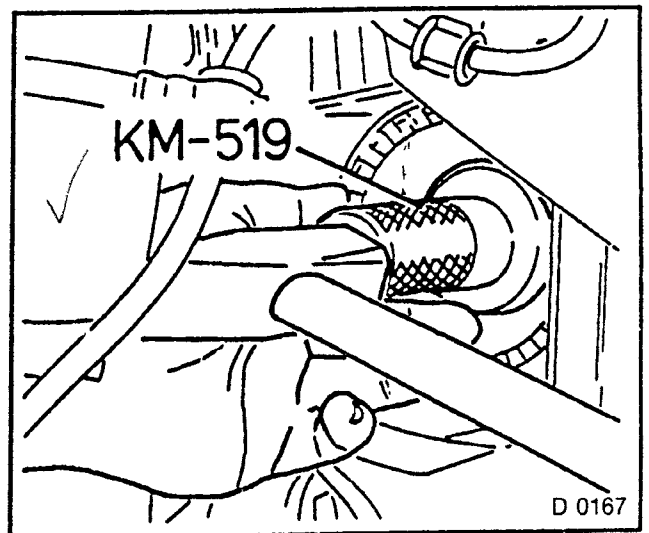


Fig. 46

### INSTALL, CONNECT

1. New retaining ring (1) on axle shaft.
2. Lubricate splines with Transmission Fluid (B0400075).
3. Insert axle shaft in transmission.
4. Place square drift on welding bead of friction welding seam (2).
5. Drive in axle shaft until it engages.

### INSPECT

1. Firm fit of axle shaft by pulling on joint circumference.  
**DO NOT** pull on shaft itself.

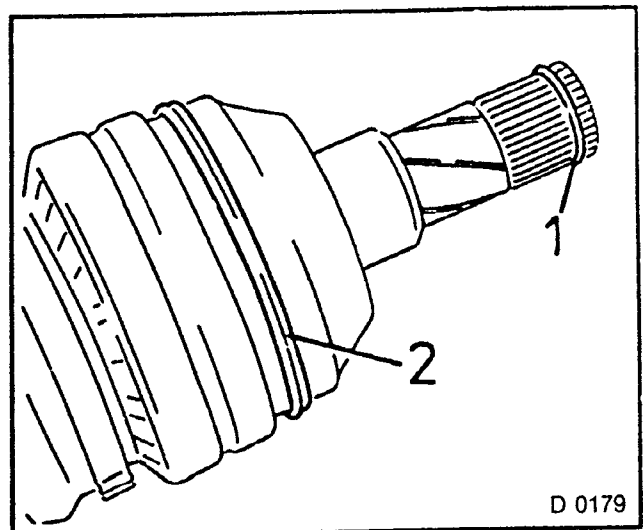


Fig. 47

**TIGHTEN (TORQUE)**

1. Castellated nuts to swivel joints, 70 Nm.
2. Secure with retaining spring.
3. If removed: stabilizer fastening to control arm — pretensioning measurement  
"1" = 38 to 39 mm.  
New nut, 20 Nm — see Section E.  
Wheel bolts, 110 Nm.

**INSPECT**

1. Transmission fluid level.
2. Install engine compartment cover.

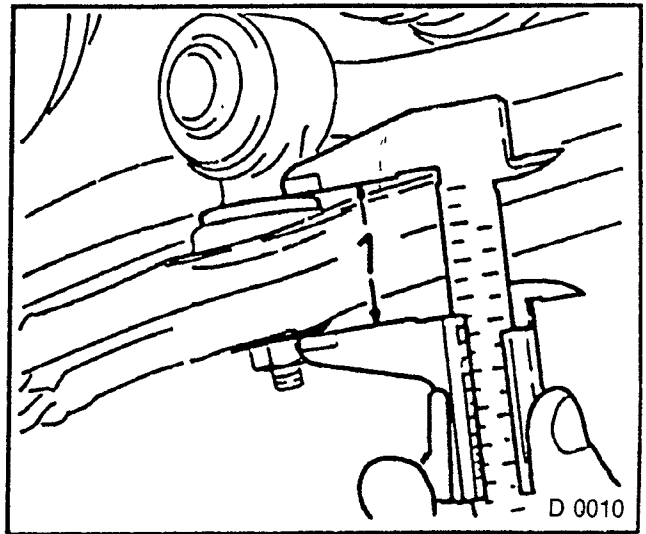


Fig 48

**RUBBER O-RING FOR SPEEDOMETER HELICAL GEAR (DRIVEN) — REPLACE****REMOVE, DISCONNECT**

1. Speedometer cable (1) and/or wiring harness plug for odometer frequency sensor (2).
2. Bolt for guide piece.
3. Lever guide piece out of transmission housing.
4. Rubber O-ring from groove.

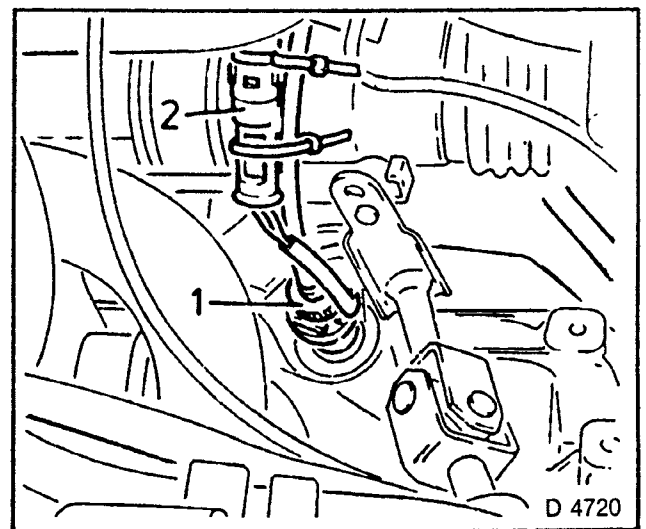


Fig. 49

**INSTALL, CONNECT**

1. New rubber O-ring (2) in groove (arrow).
2. Lubricate splines of speedometer helical gear with Bearing Grease (B0400852).
3. Insert guide piece (1) in transmission housing.

**TIGHTEN (TORQUE)**

1. Bolt (3) for guide piece (1) to transmission housing, 4 Nm.

**INSTALL, CONNECT**

1. Speedometer cable and/or wiring harness plug for odometer frequency sensor.

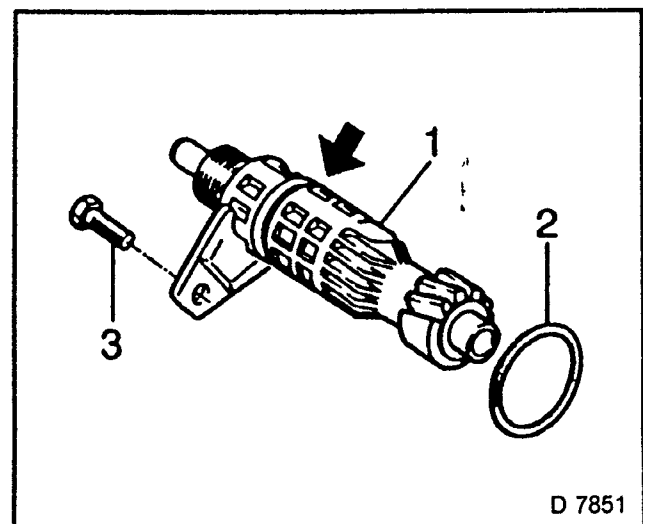


Fig. 50



## Gasket for Shift Cover — Replace

See “Shift Cover, Remove and Install” page 28. (disassembly and assembly are not necessary)

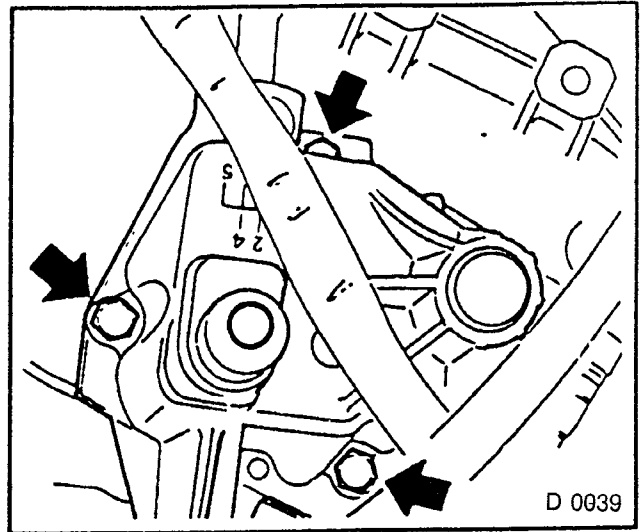


Fig 51

### NOTE:

Before installation, check the play between the dowel pin and shift rod actuation.

See “Shift Cover, Assemble and Install”, page 28.

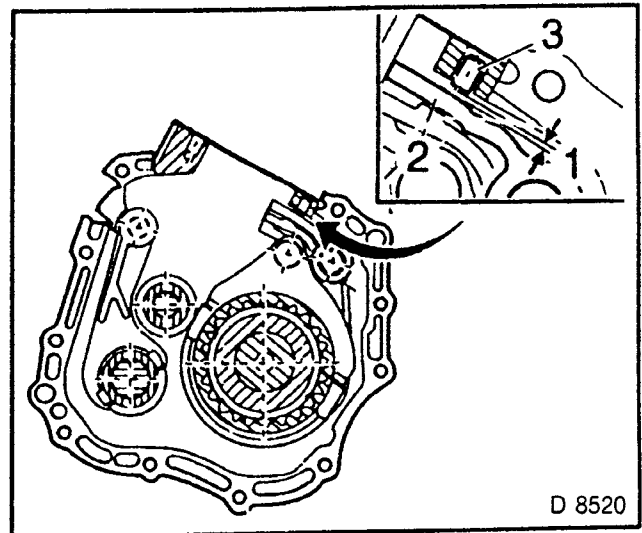


Fig 52

## Gasket for End Shield — Replace

### REMOVE, DISCONNECT

1. Ground cable from battery.
2. Shift cover.
3. Front left wheel.
4. Protective panelling from left wheel well.
5. See “Wing, Remove and Install” in Section A.
6. Reversing lamp switch.
7. Hold engine with KM-263-A and spring hook.
8. End shield cover from transmission.
9. Damper block from left front frame side member.
10. Engine suspension remains connected to transmission.

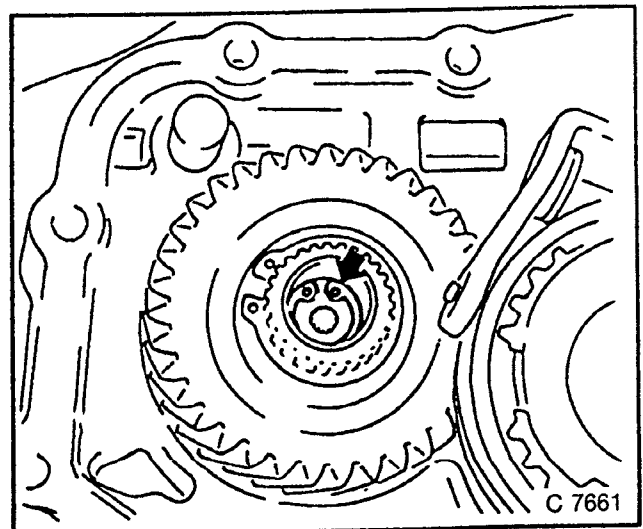


Fig 53

11. Lower engine with KM-263-A until end shield can be guided past front frame side member.  
Axle shaft **must not** lie on front axle body.
12. Remove transmission drive shaft with KM-556-1-A and KM-556-4 from clutch splines and gear cluster — see “Clutch Disc and Pressure Plate, Remove and Install” Page 90.
13. End shield from transmission.

**NOTE:  
FLUID ESCAPES.**

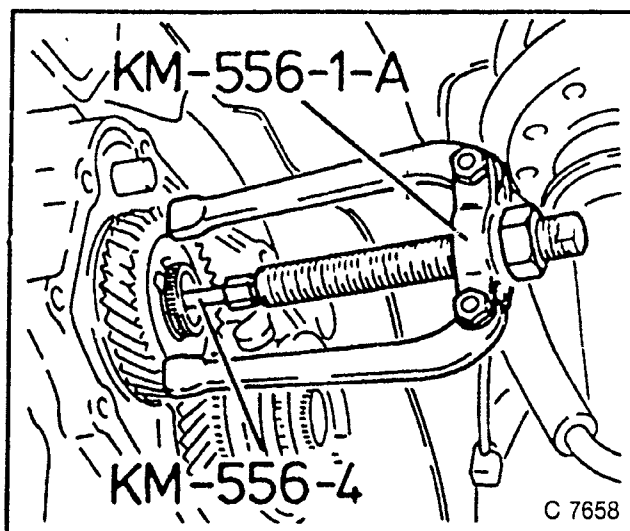


Fig. 54

**ATTACH NEW GASKET TO TRANSMISSION WITH ANTI-FRICTION BEARING GREASE.**

### TIGHTEN (TORQUE)

1. End shield to transmission,  
M 7: 15 Nm.  
M 8: 20 Nm.  
  
Note spacing washer (axle reverse idler gear) and magnet.
2. Reversing lamp switch to transmission, 20 Nm.
3. Press in transmission drive shaft to gear cluster and clutch splines. See “Clutch Disc and Pressure Plate, Remove and Install” Page 90.

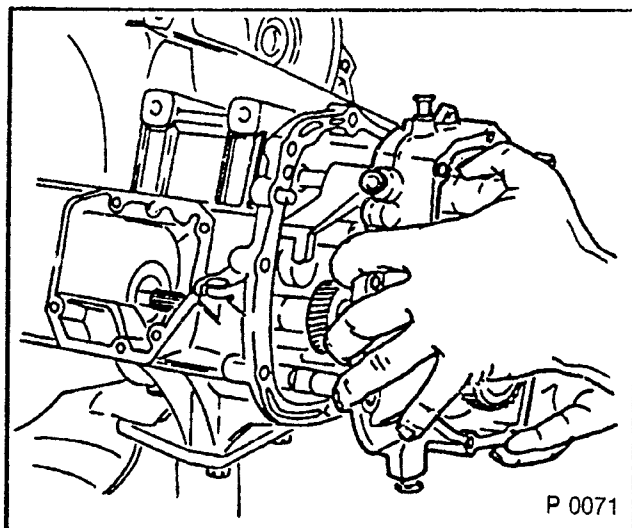


Fig. 55

4. End shield cover to transmission,  
M 7 x 1.0: 15 Nm.  
M 8 x 1 25:20 Nm.
5. Raise transmission with hydraulic jack.
6. Damper block with new bolts to front frame side member, 75 Nm.
7. Install protective panelling.
8. Wheel bolts, 110 Nm.

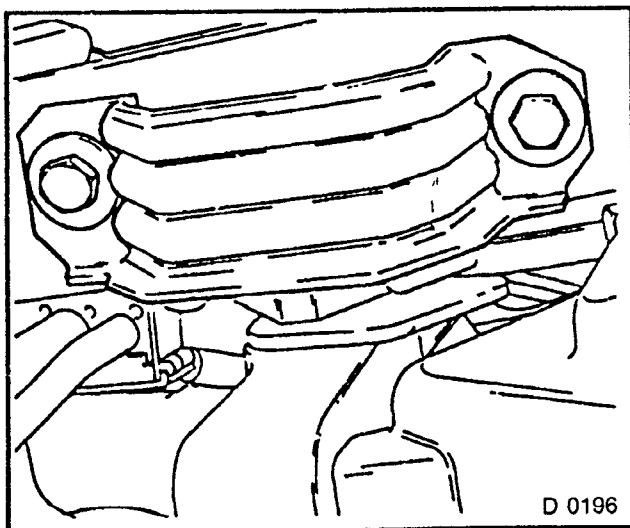


Fig. 56

Shift cover to transmission — see “Shift Cover, Assemble and Install” page 28.

**NOTE:**  
**CHECK PLAY BETWEEN DOWEL PIN AND SHIFT ROD ACTUATION BEFORE INSTALLATION.**

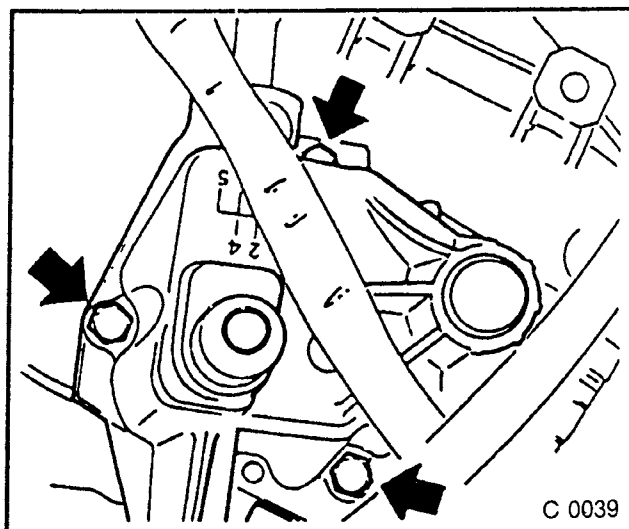


Fig. 57

## INSTALL, CONNECT

1. Lubricate new hollow pin with Silicon Grease (B0400571).
2. New hollow pin (1) at cardan joint, engage expanding springs.
3. Remove KM-263-A.
4. Ground cable to battery.
5. Fill up with Transmission Fluid (B0400075)

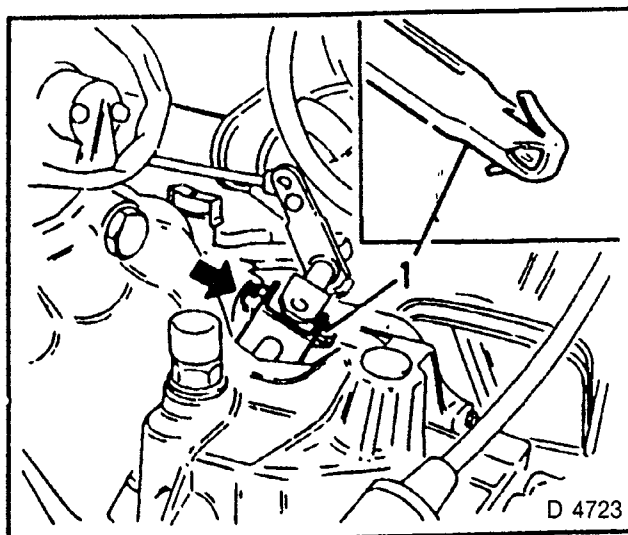


Fig. 58

## Gasket for Differential Cover — Replace

### REMOVE, DISCONNECT

1. Differential cover — fluid escapes.

### CLEAN

2. Sealing surfaces at cover and transmission.

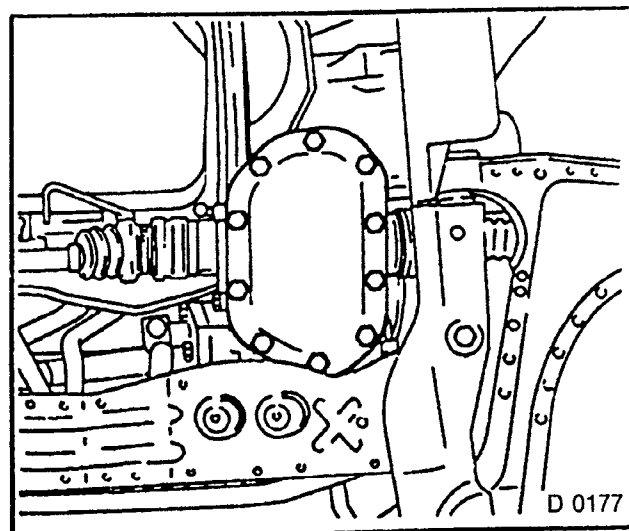


Fig. 59

3. Stick new gasket to cover with Anti-friction Bearing Grease (B0400852).

### TIGHTEN (TORQUE)

- Cover to transmission — Sheet metal version 30 Nm.  
— Light alloy version 18 Nm.

### INSPECT

- Transmission fluid level.

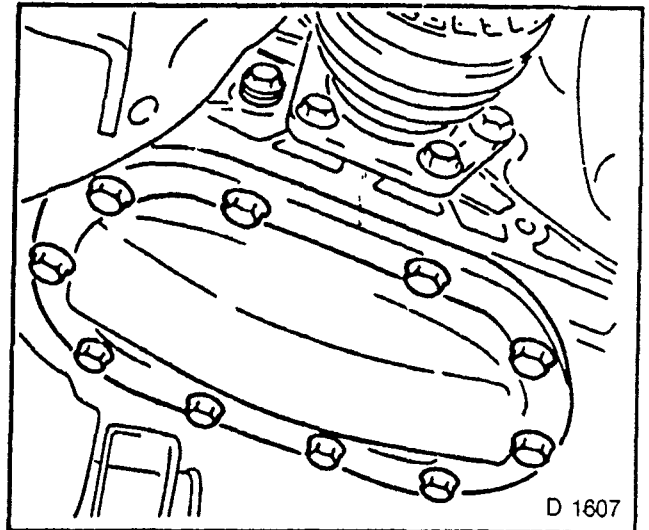


Fig 60

## OPERATIONS ON MANUAL TRANS- MISSION AND DIFFERENTIAL

### F 28/6 Manual Trans- mission; Switch for 1st Gear Recognition — Seal or Replace

#### REMOVE, DISCONNECT

1. Raise circlip.
2. Remove wiring harness plug (1).
3. Switch for 1st gear recognition (2) from manual transmission.

#### INSTALL, CONNECT

1. Screw in switch for 1st gear recognition (2) with Sealing Compound (Loctite 242), 20 Nm. Connect wiring harness plug (1), circlip must engage.

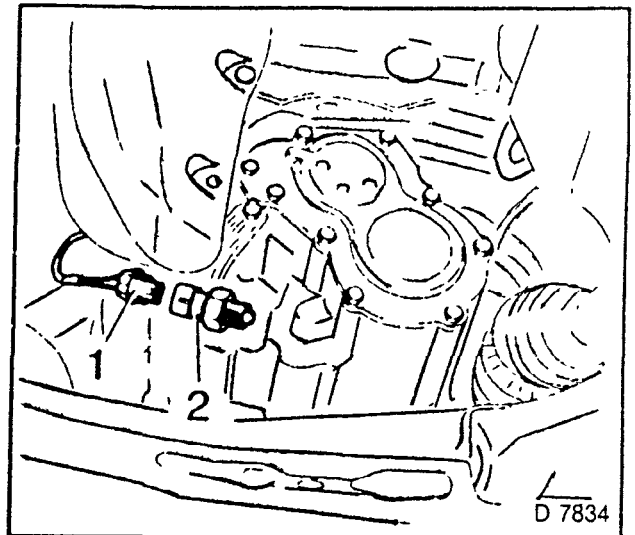


Fig. 61

### Reversing Lamps Switch — Seal or Replace

#### REMOVE, DISCONNECT

1. Raise circlip.
2. Remove wiring harness plug (1).
3. Reversing lamps switch (2) from manual transmission

#### INSTALL, CONNECT

1. Screw in reversing lamps switch (2) with Sealing Compound (Loctite 242).
2. Connect wiring harness plug (1), circlip must engage.

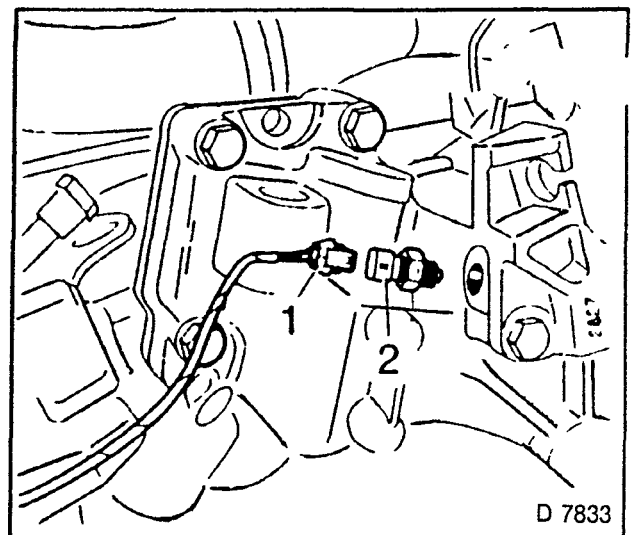


Fig. 62

## Manual Transmission and Differential — Remove and Install

### REMOVE, DISCONNECT

1. Ground cable from battery.
2. Loosen bolt for shift rod clamp (arrow).
3. Remove gearshift lever in 4th gear position — disconnect plug connection.

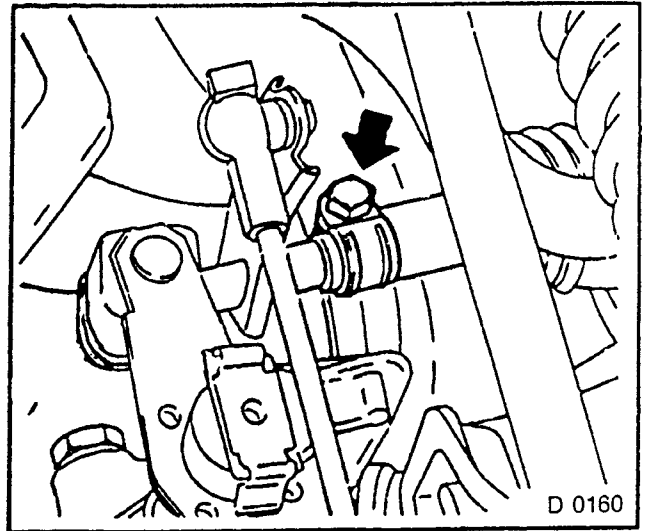


Fig. 63

### Vehicles with C 20 XE engine:

1. Disconnect oxygen sensor wiring harness plug behind coolant compensation tank.
2. Retaining clamp from clutch cable.
3. Press down release lever with installing iron.
4. Clutch cable from release lever.
5. Wiring harness plug for reversing lamps.

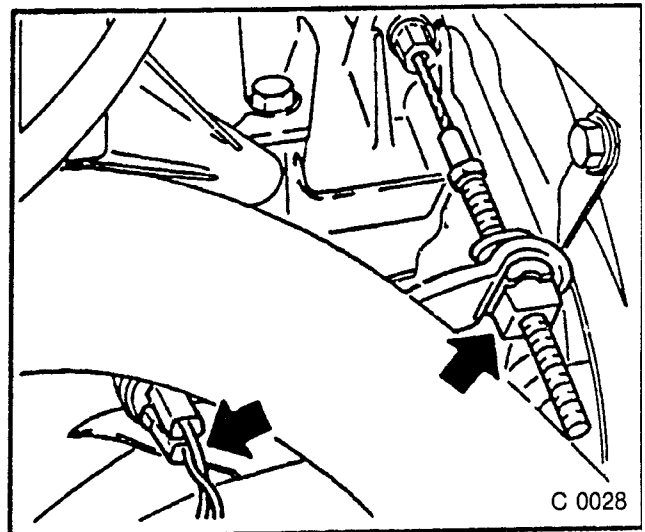


Fig. 64

### REMOVE, DISCONNECT

1. Wiring harness plug from odometer frequency sensor (2) and/or speedometer cable (1) from transmission.

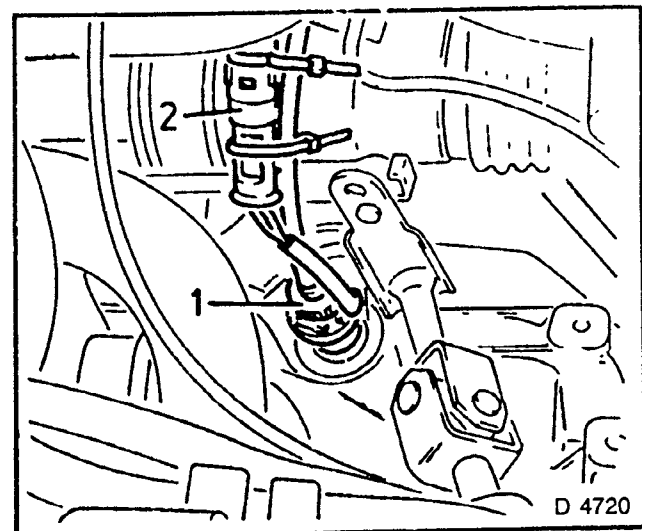


Fig. 65

2. Three upper bolts for transmission to engine.

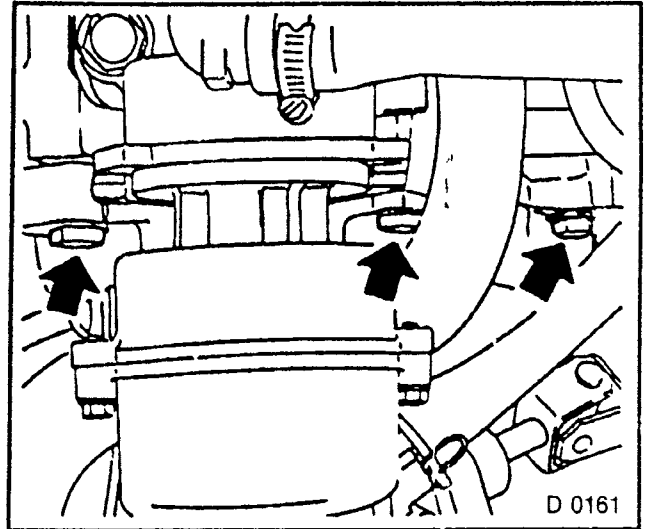


Fig 66

3. Hold engine with KM-263-A and spring hook.
4. Fasten spring hook to transport strap behind ignition distributor.

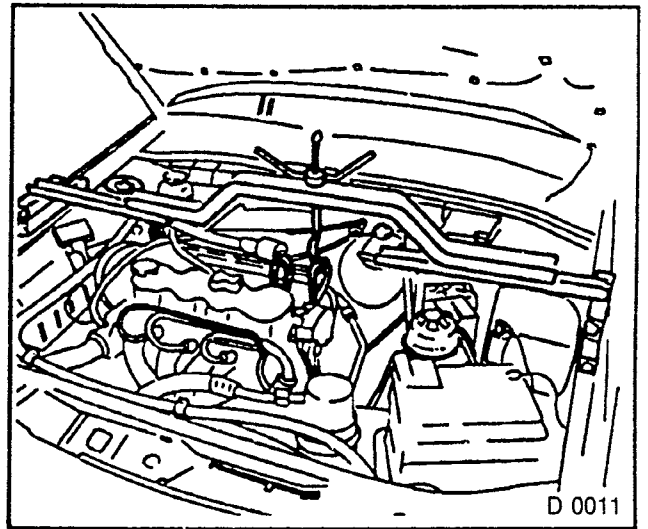


Fig 67

## REMOVE, DISCONNECT

1. Both front wheels.
2. Engine compartment cover.
3. Front exhaust pipe with plug connection if connection flanged or jointed: Separate exhaust at flange or joint only.  
Front axle body — see Section E.

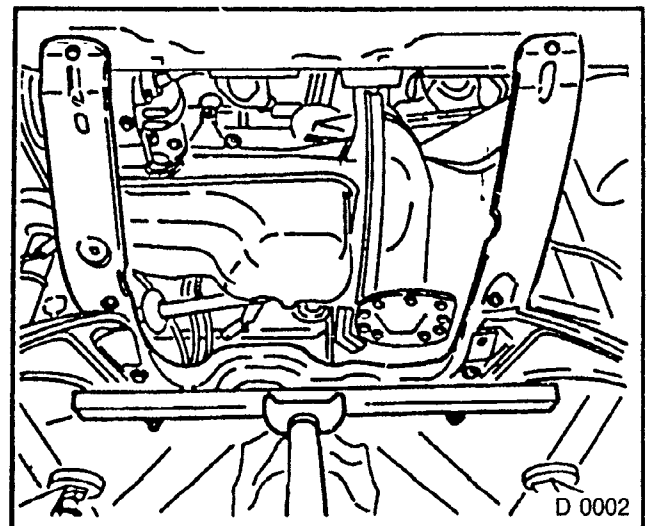


Fig. 68

**REMOVE, DISCONNECT**

Remove axle shafts — see operation “Axle Shaft Seal Rings, Replace”

**WARNING:**  
**FLUID ESCAPES. CLOSE**  
**OPENINGS. TIE UP AXLE SHAFTS.**

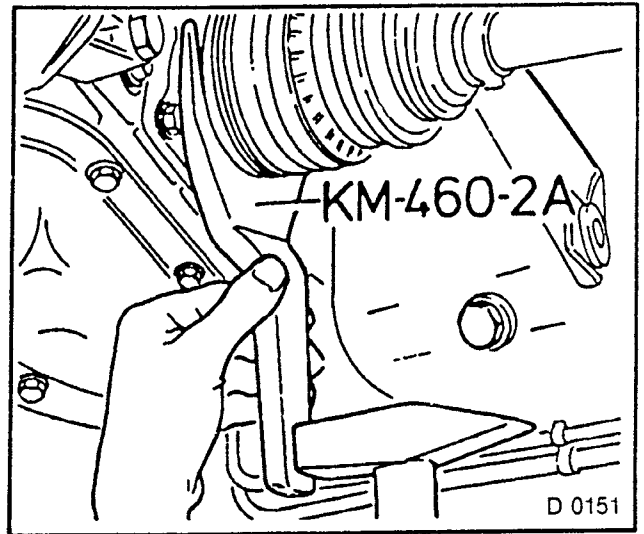


Fig. 69

**REMOVE, DISCONNECT**

1. Engine suspension bracket, front left.  
 Vehicles with F28/6 manual transmission — Ground cable from manual transmission. Wiring harness plug from 1st gear recognition switch.  
 Other transmissions — Ground cable from end shield cover.
2. Lower vehicle.
3. Lower engine by approximately 5 cm with KM-263-A.  
 Release lever is located below front frame side member.

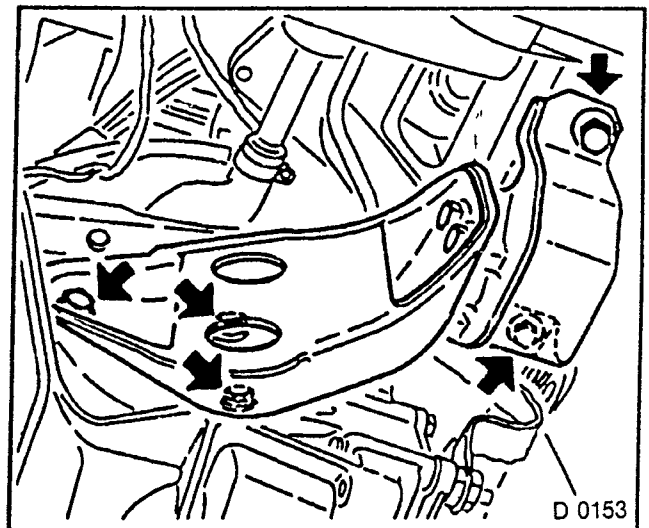


Fig. 70

4. Raise vehicle.
5. Pull transmission drive shaft out of clutch splines and gear cluster — See “Clutch Disc and Pressure Plate, Remove and Install” Page 90.
6. Bolt KM-444-B to transmission, 65 Nm.
7. Support transmission with hydraulic jack and KM-444-B.
8. Bolt two detent pins to KM-444-B.

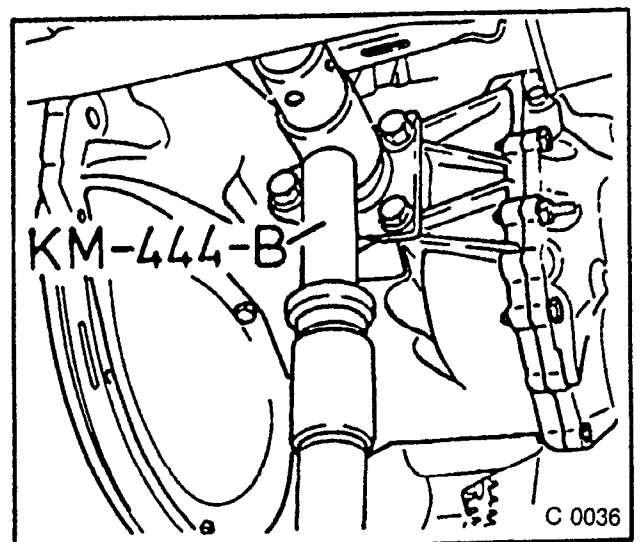


Fig. 71



**REMOVE, DISCONNECT**

1. Cover plate from transmission (A).
2. Transmission from engine (B).
3. Press transmission off engine block and lower.

**WARNING:**  
**WHEN LAYING ASIDE THE TRANSMISSION, DO NOT DAMAGE ATTACHING PARTS.**

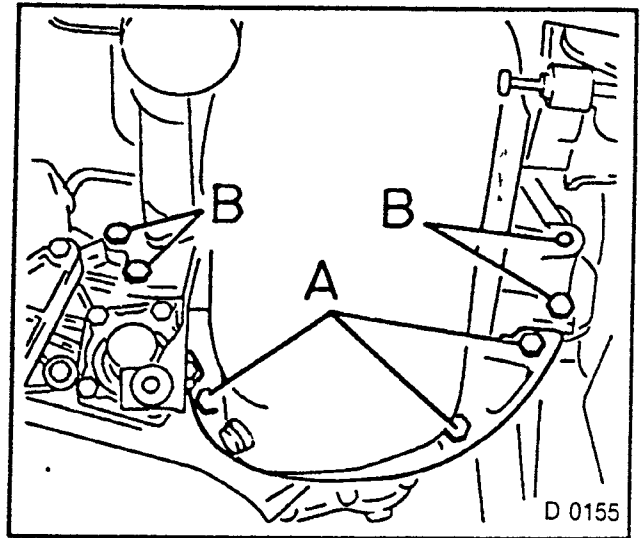


Fig. 72

**INSPECT**

1. Easy movement of threaded bores for damper block on left front frame side member; if necessary recut M 10 x 1.25.
2. Install transmission with KM-444-B on hydraulic jack.

3. Attach transmission to engine block.

**TIGHTEN (TORQUE)**

1. Transmission to engine block (B), 75 Nm.
2. Cover plate to transmission (A), 7 Nm.

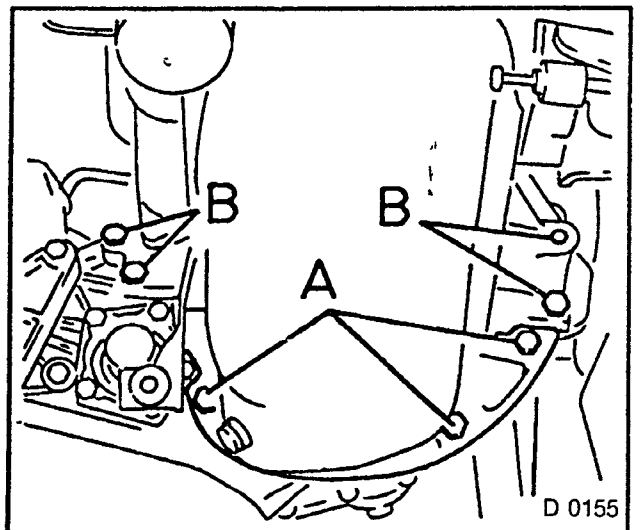


Fig. 73

3. Raise transmission until KM-564 can be applied to end shield.
4. Press in drive shaft. See "Clutch Disc and Pressure Plate, Remove and Install" Page 90.

### INSTALL, CONNECT

1. Ground cable to end shield cover  
F28/6 manual transmission — ground cable to manual transmission Wiring harness plug to 1st gear recognition switch.

### REMOVE, DISCONNECT

1. KM-444-B.

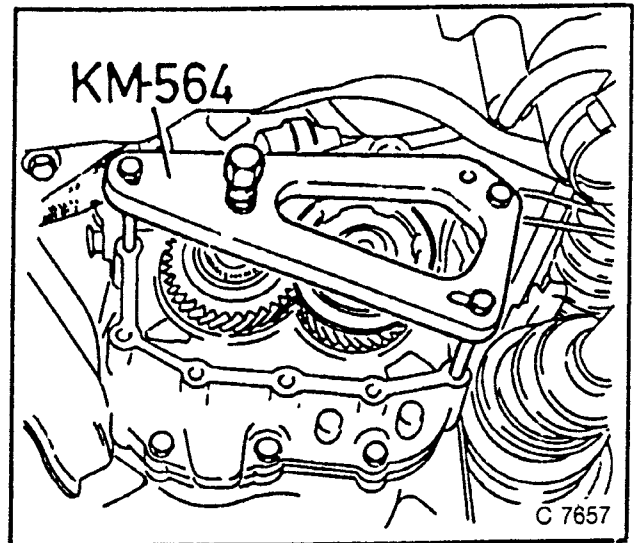


Fig. 74

2. Align transmission with hydraulic jack.

### TIGHTEN (TORQUE)

1. Bolts for engine suspension to transmission, 65 Nm.
2. Two new bolts for damper block to front frame side member, 75 Nm.

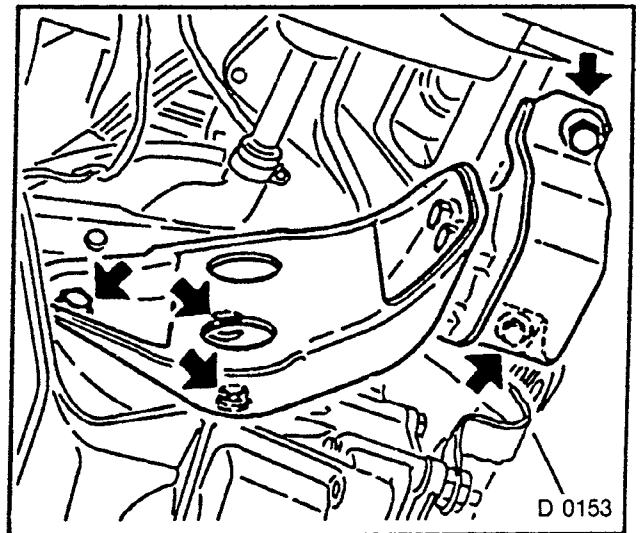


Fig. 75

### INSTALL, CONNECT

1. Cable for reversing lamp switch (front side of transmission).
2. Both axle shafts — See "Axle Shaft Seal Rings, Replace" Page 30.
3. Front axle body — See Section E.

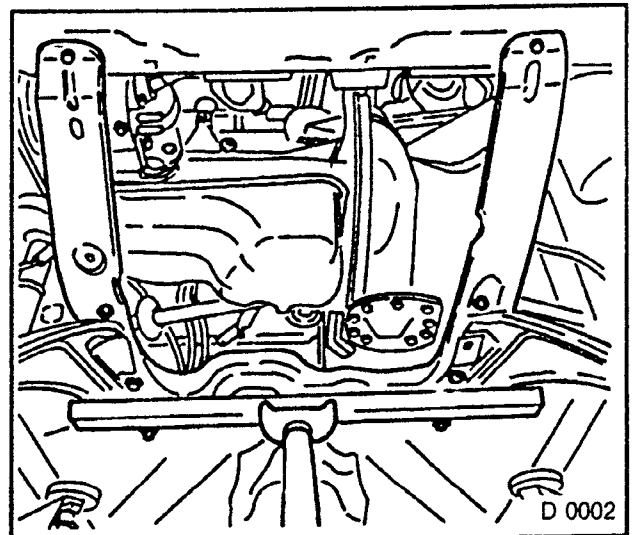


Fig. 76

4. Front exhaust pipe with plug connection.
5. Flanged or jointed connection.  
Bolt exhaust with new gasket to flange/joint — see Section L.
6. Lower vehicle.

### REMOVE, DISCONNECT

1. KM-263-A.

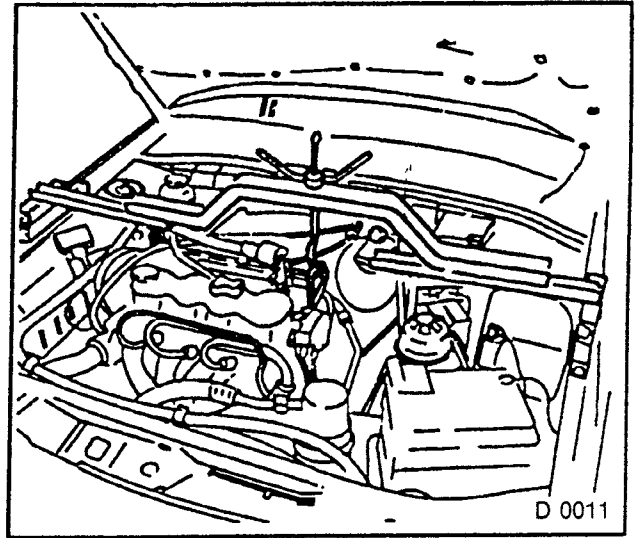


Fig. 77

### TIGHTEN (TORQUE)

1. Wheel bolts, 110 Nm.
2. Transmission to engine block, 75 Nm.

### INSTALL, CONNECT

1. Speedometer cable and/or wiring harness plug for odometer frequency sensor.
2. Clutch bowden cable.
3. Secure with retaining clamp.
4. Shift rod to knurled bolts of shift linkage lever. Only tighten clamp screw after adjustment.
5. Ground cable to battery.

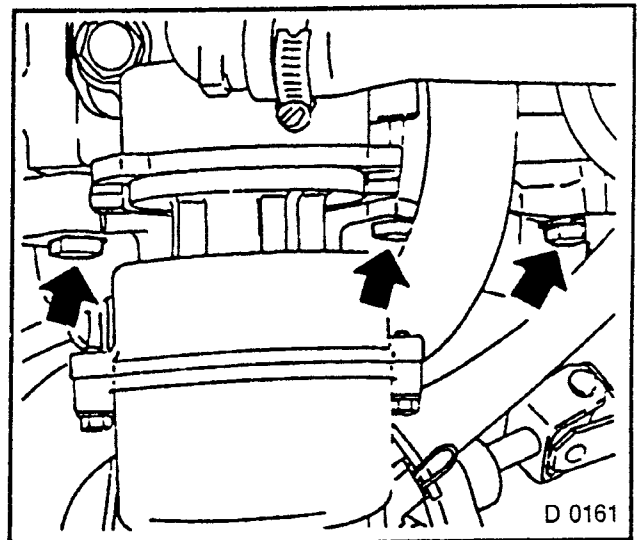


Fig. 78

### INSPECT

1. Transmission fluid level

### INSTALL, CONNECT

1. Engine compartment cover.

### ADJUST

1. Transmission shift linkage.

## Transmission Housing — Replace

Remove transmission KM-444-B (65 Nm and KM-489 to transmission;  
transmission to transmission support.

### DISASSEMBLE

1. Shift cover from transmission
2. End shield with main shaft and drive shaft from transmission.
3. Differential.
4. Clutch pressure bearing and clutch fork.
5. Clutch release lever and clutch pressure bearing guide.
6. Clutch cover from transmission.
7. Both bearing bushings for clutch release lever, KM-304
8. Speedometer helical gear (driven).

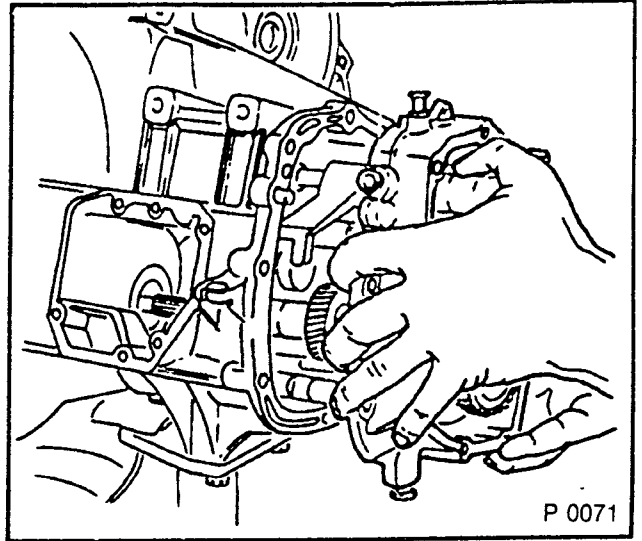


Fig. 79

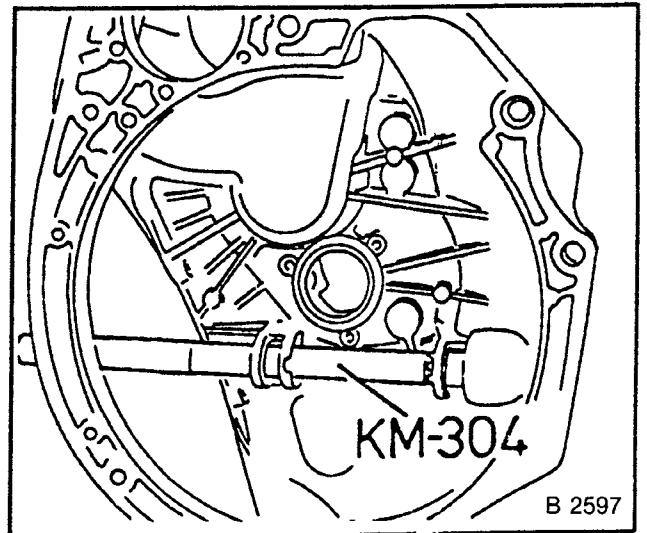


Fig. 80

### F 10/F 13 MANUAL TRANSMISSION:

#### REMOVE, DISCONNECT

1. Needle sleeve for bearing of drive shaft, KM-454-1 and KM-454-4

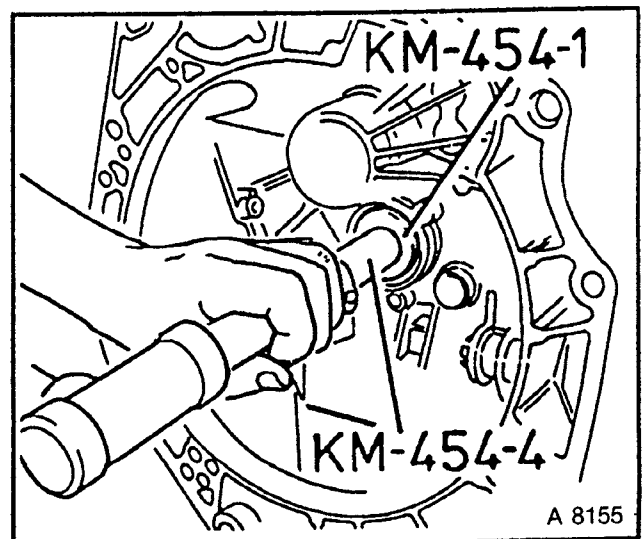


Fig. 81

**INSTALL, CONNECT**

1. Drive in needle sleeve for bearing of drive shaft flush with lettered side to transmission, KM-454-2 and KM-454-4

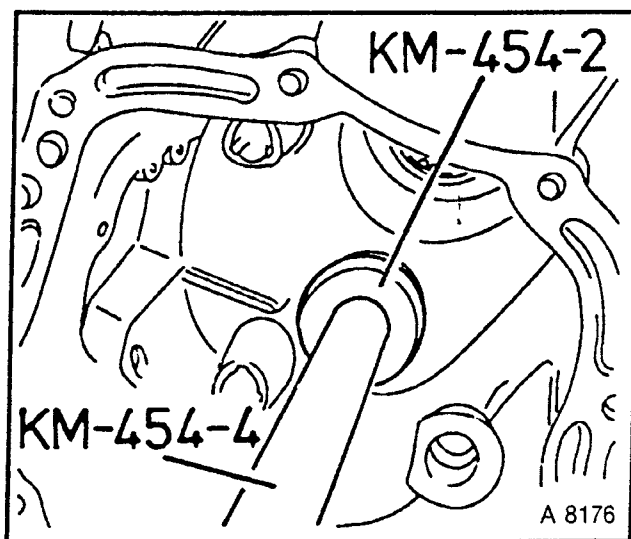


Fig 82

**F 10/F 13 MANUAL TRANSMISSION:****REMOVE, DISCONNECT**

1. Needle sleeve for bearing of main shaft, KM-556-A or Kukko Remover 21/4 with Counterhold 22-1

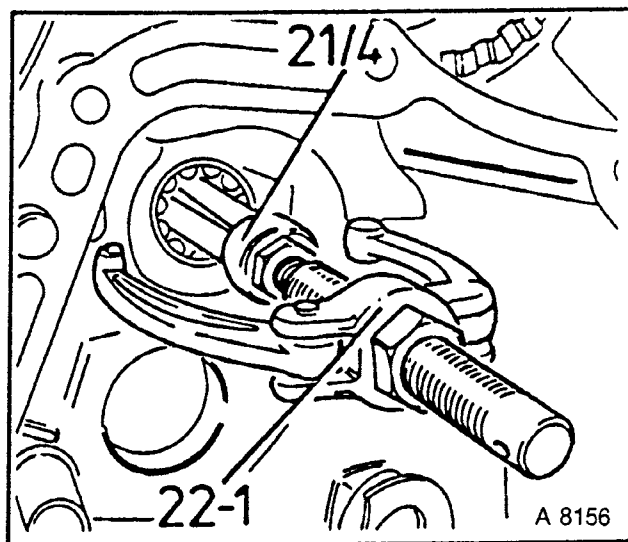


Fig. 83

**INSTALL, CONNECT**

1. Drive in needle sleeve for bearing of main shaft flush KM-454-3 and KM-454-4.

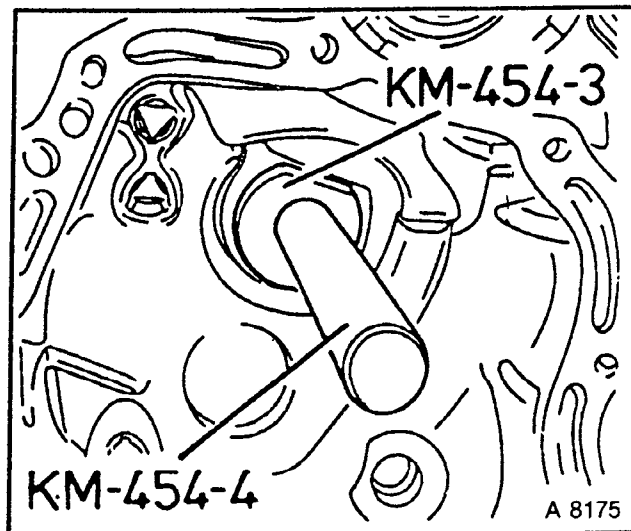


Fig. 84

**F 16/F 20 MANUAL TRANSMISSION:****REMOVE, DISCONNECT**

1. Needle sleeve for bearing of drive shaft, KM-523-1 and KM-523-3.
2. Outer ring of roller bearing for main shaft, KM-J-26941 (1), KM-483 (2) and KM-313 (3)

If difficult to move, heat transmission housing with hot-air dryer.

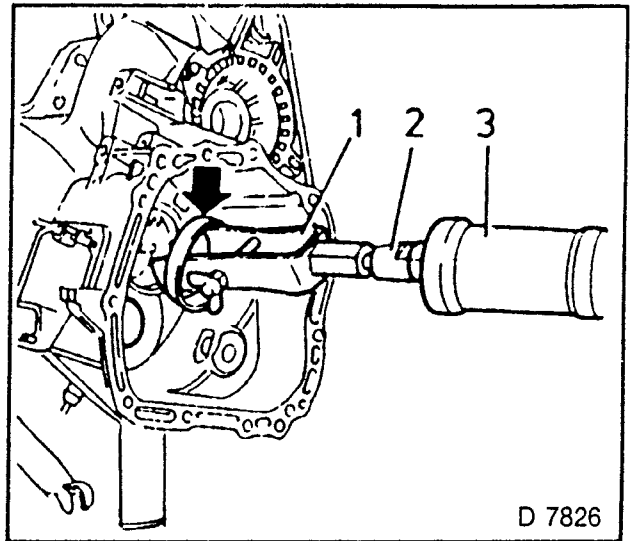


Fig. 85

**INSTALL, CONNECT**

1. Drive in needle sleeve for bearing of drive shaft flush with lettered side to transmission, KM-523-1 and KM-523-2.
2. Press in outer ring of roller bearing for main shaft to stop (do not drive in), KM-523-1 and KM-523-4.

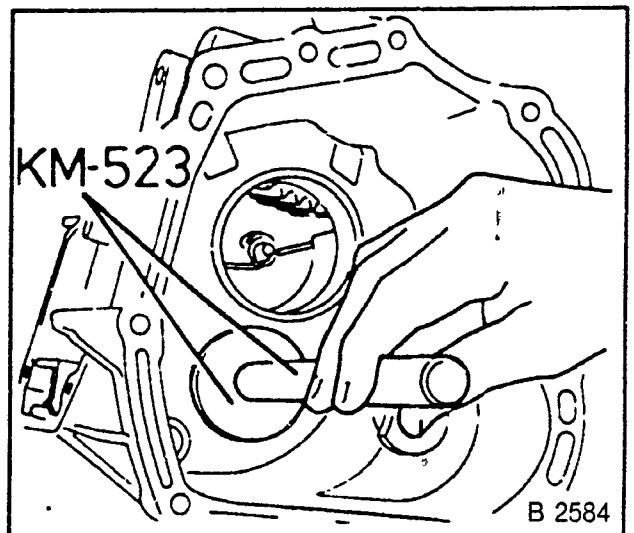


Fig. 86

**TIGHTEN (TORQUE)**

1. Drive in both bearing bushing for clutch release lever, KM-304.
2. Insert bushing cams in housing recesses.
3. Coat inside of bushings. Molybdenum Disulphide Paste.

Differential

See corresponding operations.

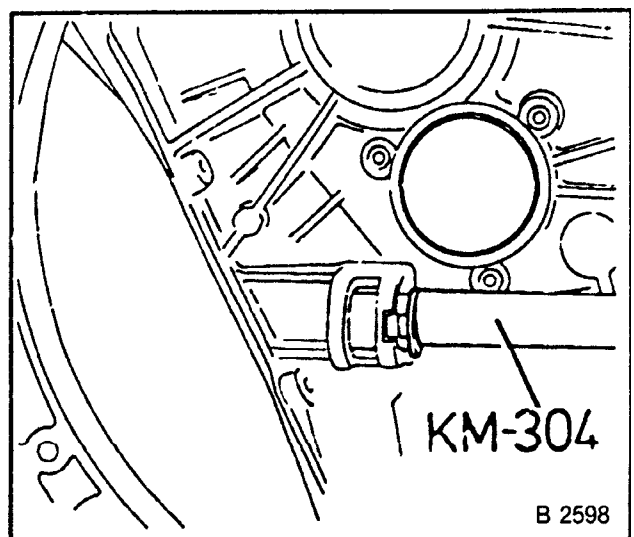


Fig 87

**TIGHTEN (TORQUE)**

1. End shield to transmission,  
M 7: 15 Nm  
M 8: 20 Nm.
2. Clutch pressure bearing guide, 5 Nm.
3. Clutch release lever to transmission.
4. Clutch fork to clutch release lever,  
35 Nm.
5. Clutch pressure bearing to clutch fork.
6. Clutch closure plate to transmission:  
sheet metal version, 12 Nm.  
light alloy version, 6 Nm.
7. Shift cover to transmission  
(measurement required).
8. Install transmission.

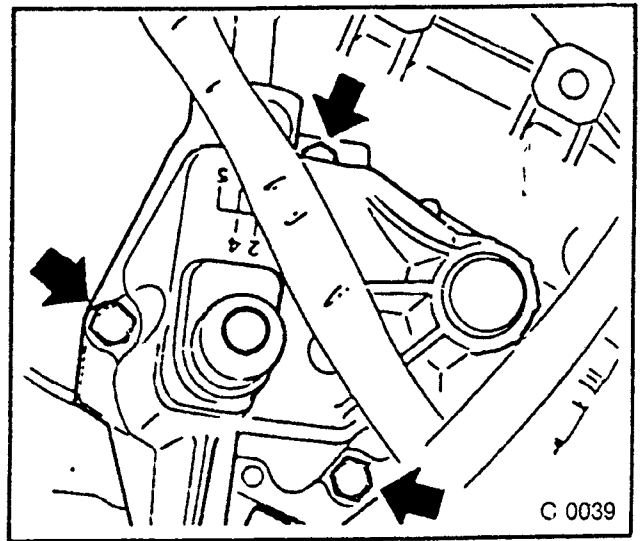


Fig. 88

## DIFFERENTIAL, OVERHAUL

### Differential — Remove and Disassemble

F 10, F 13 TRANSMISSION INSTALLED

#### REMOVE, DISCONNECT

1. Axle shafts from transmission — see “Axle Shaft Seal Rings, Replace” page 30.
2. Differential cover from transmission.
3. Mark bearing ring position in relation to transmission (arrow).

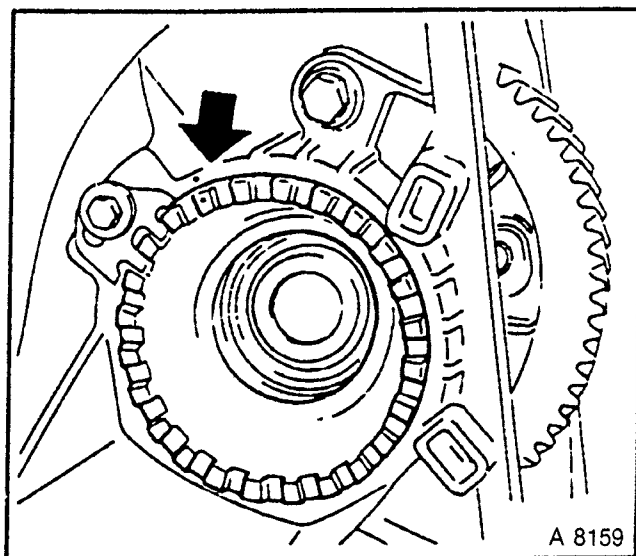


Fig. 89

#### INSPECT

1. Play of tapered roller bearings.
2. Move differential housing in axial direction. Allow for possible play in assembly” — see “Tapered Roller Bearing (Differential), Prescribed Adjustment” Page 58.

#### REMOVE, DISCONNECT

1. Locking plate from bearing ring.
2. Bearing ring, KM-447.
3. Differential from transmission.

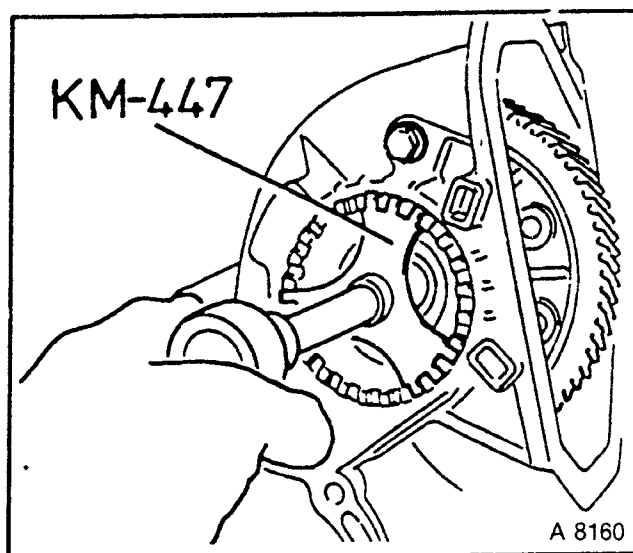


Fig. 90

#### REMOVE, DISCONNECT

1. Seal ring from bearing ring and transmission, KM-454-2 and KM-454-4. **Only necessary if bearings are replaced.**
2. Tapered roller bearing outer race from bearing ring, KM-304 and KM-451, place KM-303 underneath.

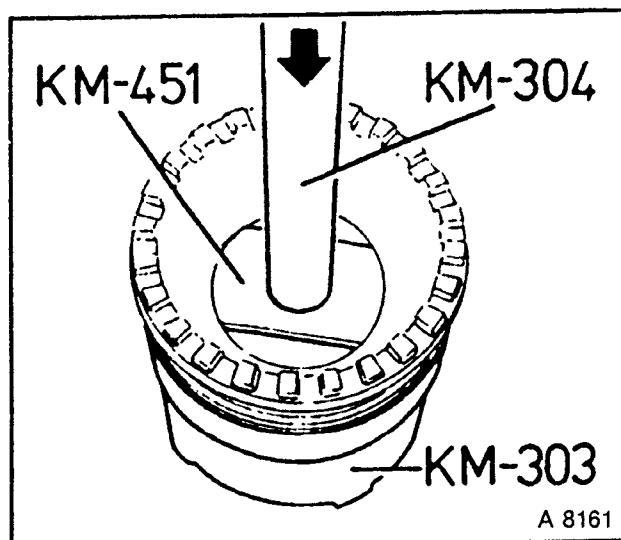


Fig. 91



**Only necessary if bearings are replaced.**

1. Tapered roller bearing outer race from transmission, KM-304 and KM-451. If transmission has been removed, KM-304 and KM-451.

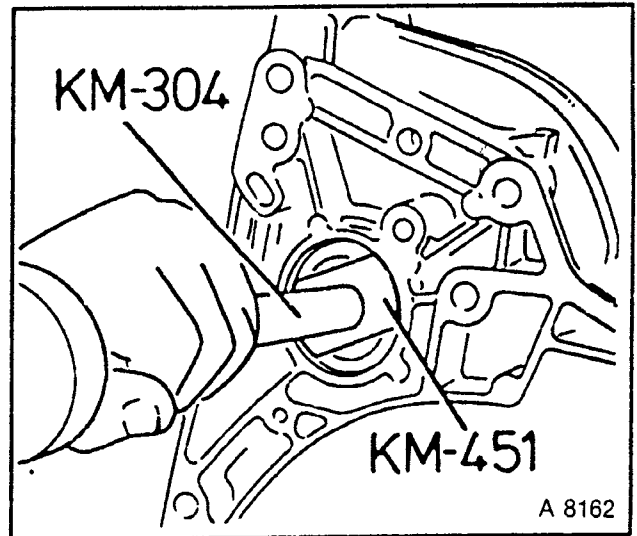


Fig 92

**Only necessary if replaced****REMOVE, DISCONNECT**

1. Both tapered roller bearing inner races from differential housing, KM-161-A, KM-161-3, KM-161-4.

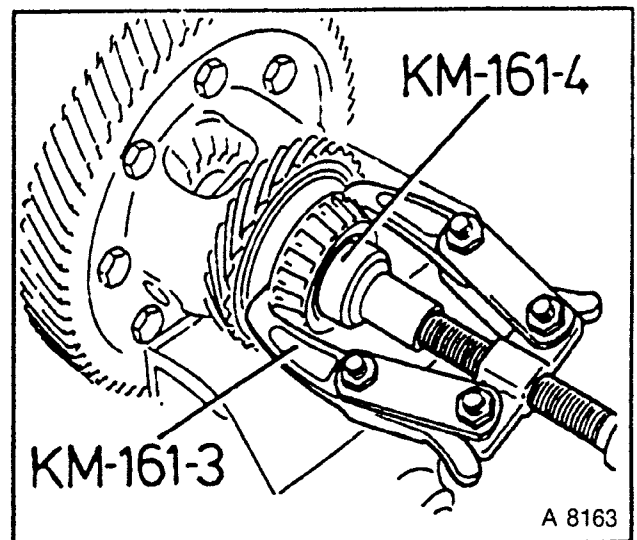


Fig. 93

2. Drive gear from differential housing.
3. Knock off drive gear, brass drift.

**NOTE:**  
 Always replace drive gears in pairs (driving and driven). Observe groove marking around tooth head circumference — see "Technical Data".

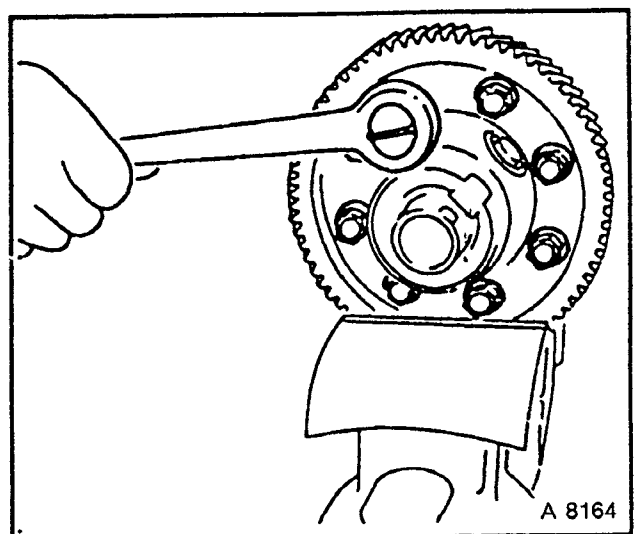


Fig. 94

Only necessary if replaced:

### REMOVE, DISCONNECT

- 1 Drive off speedometer helical gear (driving) from differential housing (destroys gear).
- 2 Retaining rings from bevel gear axle.
- 3 Bevel gear axle.

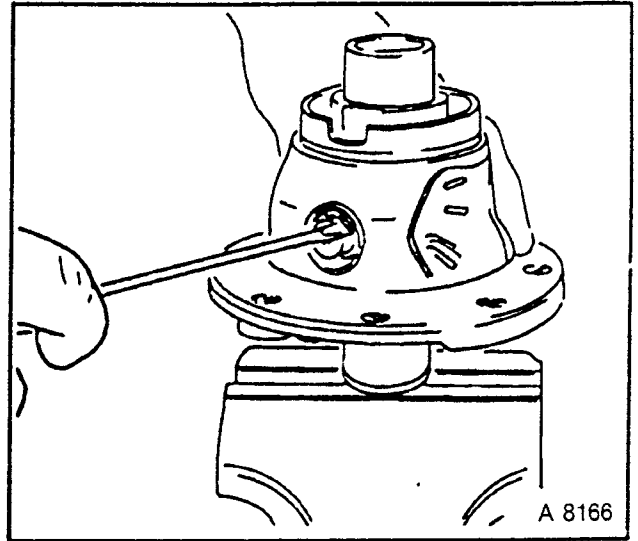


Fig 95

4. Screw out differential and axle shaft bevel gears.
5. Remove friction washers.
6. Clean removed parts.

### INSPECT

1. Removed parts for wear, scuffing, damage, hairline cracks; replace if necessary.
2. Lubricate rotating parts with Transmission Fluid BO 400075 at the bearing, running, seating and pressing surfaces.

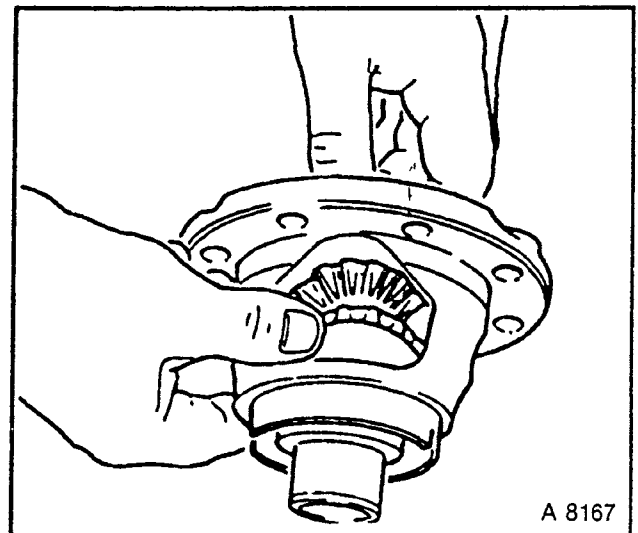


Fig 96

## Differential — Remove and Disassemble

F 16 AND F 20:

Transmission installed, illustrations show removed transmission.

### REMOVE, DISCONNECT

1. Axle shafts — see “Axle Shaft Seal Rings, Replace” Page 30.
2. Differential cover from transmission.
3. Mark bearing ring position relative to transmission (arrow).

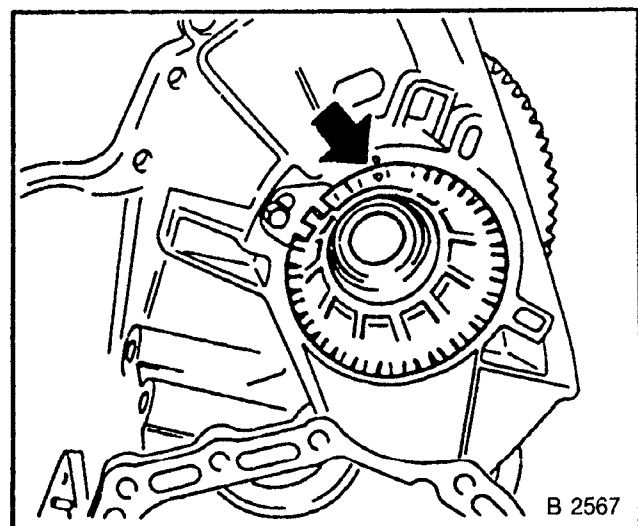


Fig. 97

**INSPECT**

1. Play of tapered roller bearings.
2. Move differential housing in axial direction.
3. Allow for possible play when assembling — see "Tapered Roller Bearings (Differential), Prescribed Adjustment" Page 58.

**REMOVE, DISCONNECT**

1. Locking plate from bearing ring.
2. Bearing ring, KM-520.

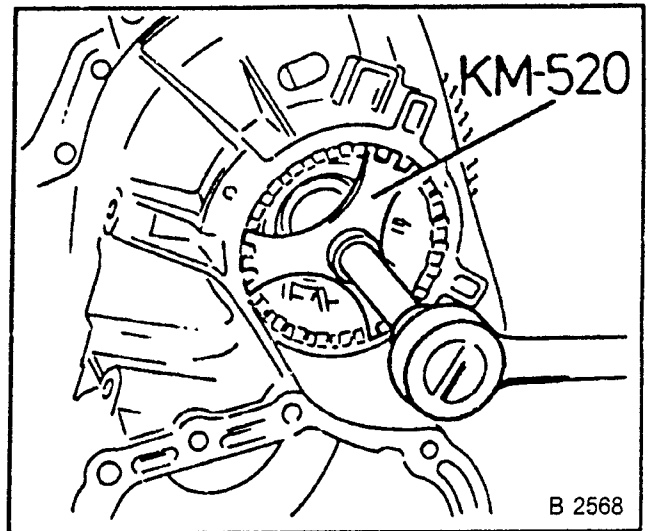


Fig. 98

**REMOVE, DISCONNECT**

1. Bearing flange from transmission.
2. Differential from transmission.
3. Replace rubber O-rings on bearing flange and bearing ring.

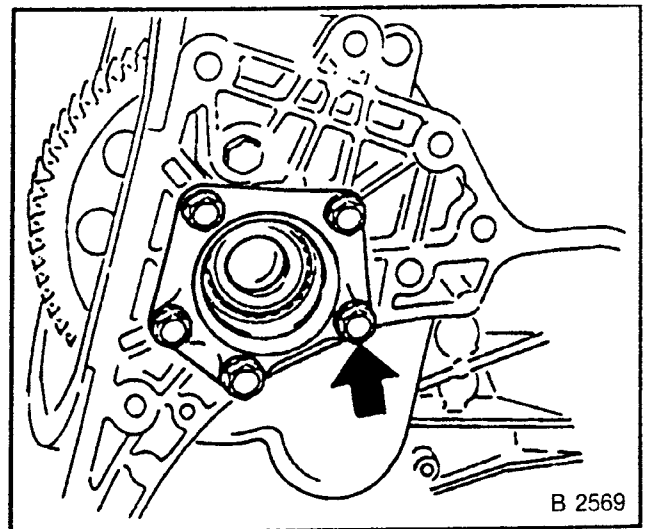


Fig. 99

4. Both seal rings from bearing flange and bearing ring, KM-466-3.
5. Place KM-466-2 underneath. Only necessary if replacement: tapered roller bearing outer races from bearing ring and bearing flange, KM-304, KM-451, place KM-502-A underneath.

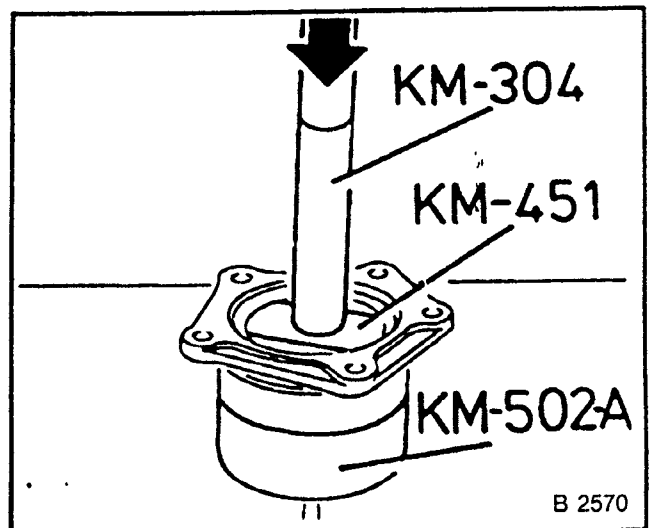


Fig. 100

Only necessary if replaced:

### REMOVE, DISCONNECT

1. Both tapered roller bearing inner races, KM-161-A

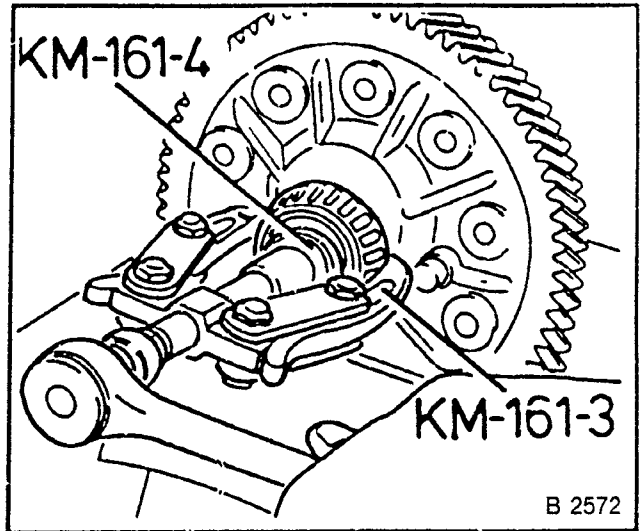


Fig 101

2. Drive off (destroy) speedometer helical gear from differential housing. At same time, correct seat of remover hooks under tapered roller bearing inner race on speedometer side.

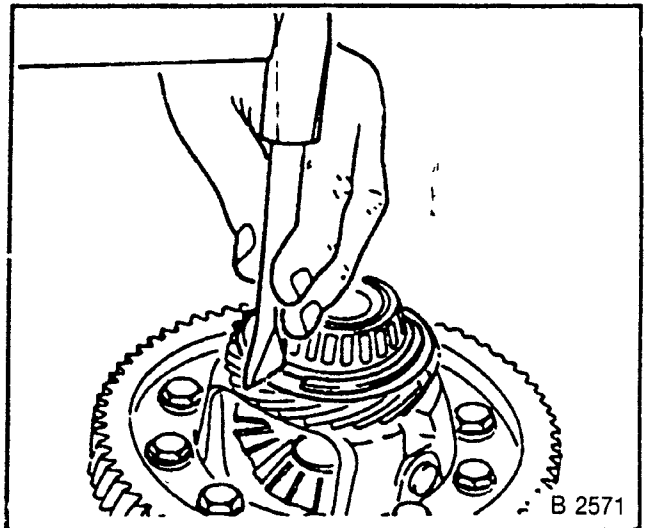


Fig 102

### REMOVE, DISCONNECT

1. Drive gear (driven) from differential housing — brass drift.

#### NOTE:

Always replace drive gears (driving gear with main shaft) in pairs. Note groove identification running around tooth tip — see "Technical Data" Page 263.

Following illustrations show further disassembly without replacement of tapered roller bearing inner races.

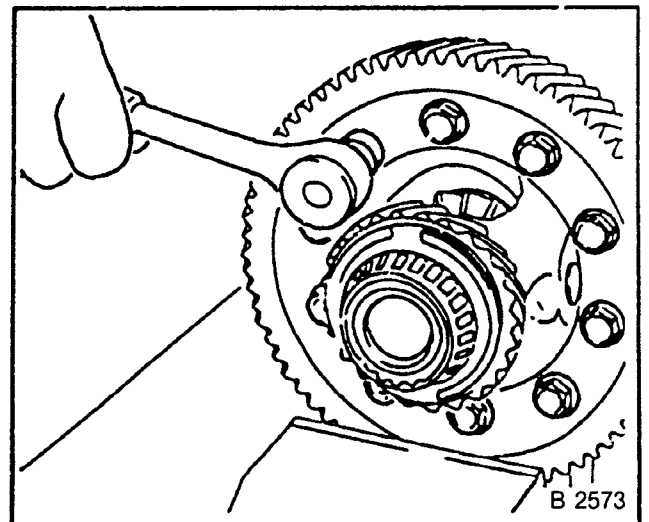


Fig 103

**REMOVE, DISCONNECT**

1. Drive out pin for securing bevel gear axle.
2. Bevel gear axle from differential housing.

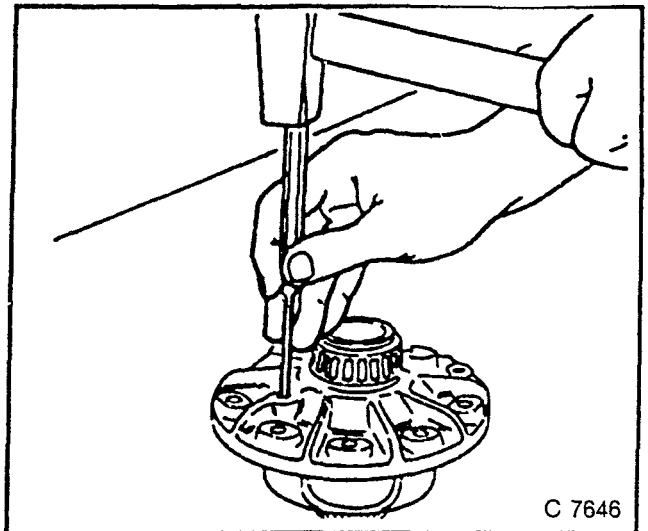


Fig. 104

**REMOVE, DISCONNECT**

1. Differential and axle shaft bevel gears from differential housing.  
Belleville spring washers and flat friction washers from bevel gears.  
On F 20, belleville spring washers from axle shaft gears, as well.

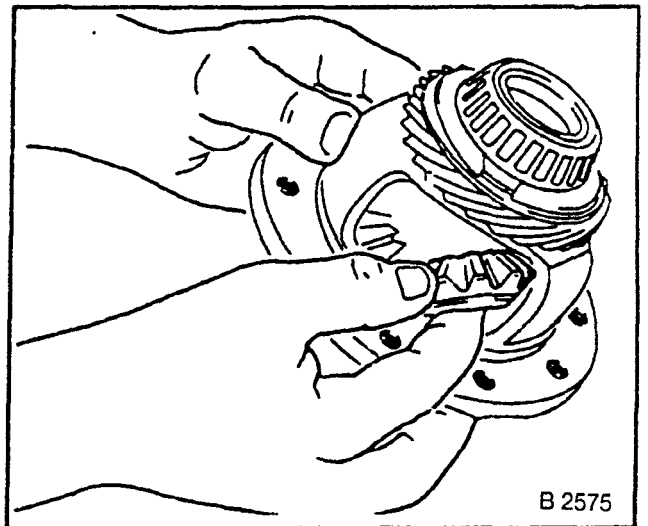


Fig 105

**CLEAN**

1. Removed parts, differential housing.

**INSPECT**

1. Removed parts for wear, scuffing, damage, hairline cracks; replace if necessary.
2. Lubricate rotating parts with Transmission Fluid (B0400075) at their bearing, running, seating and pressing surfaces.

## Differential — Assemble and Install

F 10, F 13:

### INSTALL, CONNECT

1. Axle shaft gears and differential bevel gears, belleville spring washers and bevel gear axle in differential housing.
2. Pre-install differential bevel gears and belleville spring washers, KM-456.
3. Install axle shaft bevel gears and belleville spring washers in differential housing.
4. Tension differential housing in vice, KM-458-A.
5. Bevel gear axle.
6. New retaining rings (grip set 12, commercially available).
7. New speedometer helical gear to differential housing, KM-459.
8. Heat speedometer helical gear and KM-459 to 80°C/176°F (water bath, suitable temperature gauge)
9. Gear cams must align with recesses in housing.
10. Grease splines: Anti-friction Bearing Grease (B0400852).

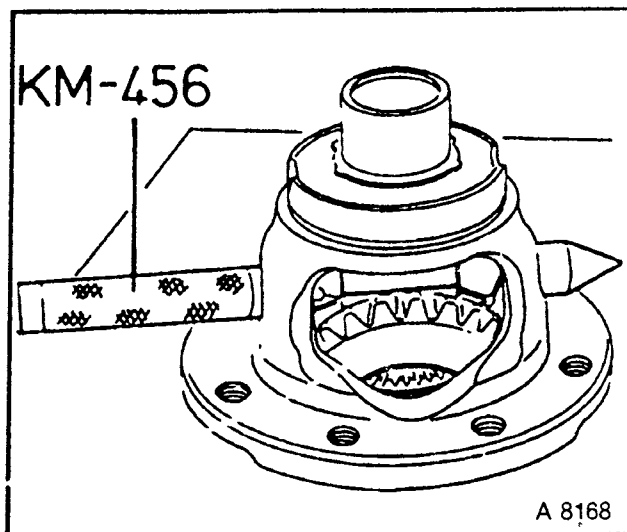


Fig 106

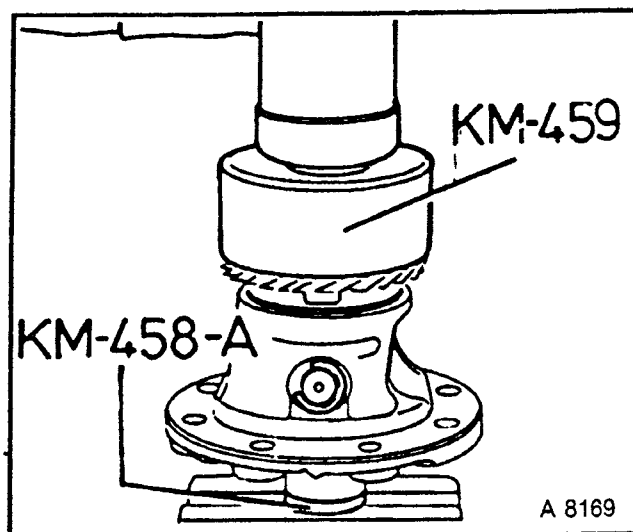


Fig 107

### TORQUE — ANGLE METHOD

1. Drive gear with new bolts to differential housing, 70 Nm plus 30° to 45°.
2. Heat drive gear to 80°C/176°F (check temperature with thermocolour pencils, if available, or suitable temperature gauge).

#### NOTE:

Always replace drive gears (driving and driven) in pairs. Observe circular grooved identification — Technical Data. Press tapered roller bearing inner races onto differential housing, KM-453.

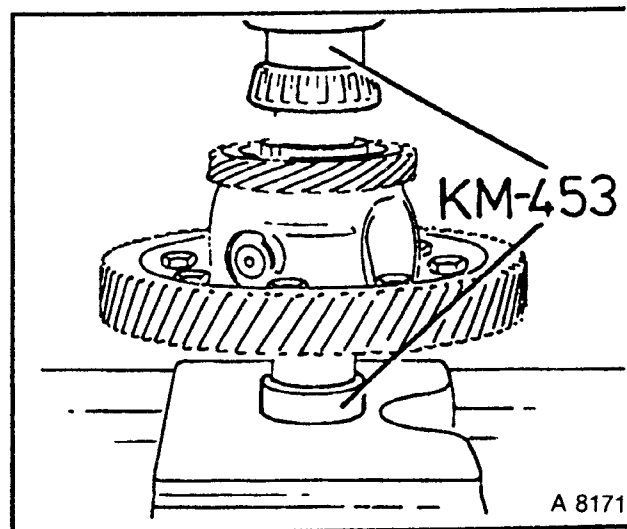


Fig 108

**INSTALL, CONNECT**

1. Each tapered roller bearing outer race in transmission or bearing ring, KM-120-2 and KM-451 (transmission installed).
2. Tap tapered roller bearing outer race lightly into housing.
3. With transmission removed: KM-304 and KM-451 may be used for both sides.

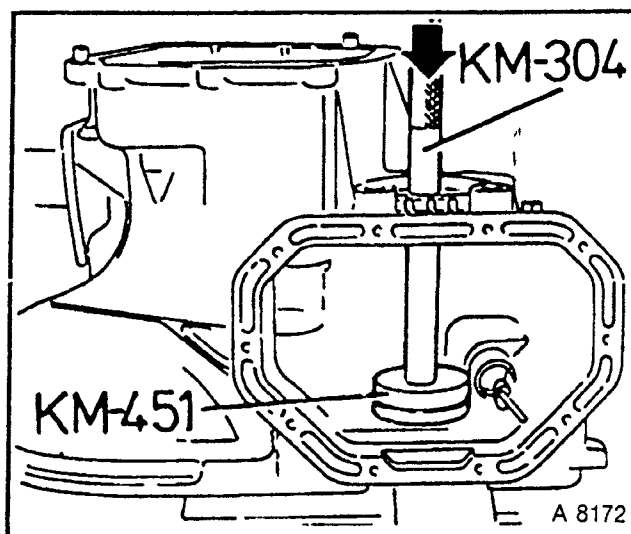


Fig. 109

**INSTALL, CONNECT**

1. Drive in new axle shaft seal rings flush in bearing ring or transmission, KM-446. Dust lip points outwards.
2. Fill sealing lips with Multipurpose Grease.
3. Differential in transmission.
4. Bearing ring in housing, KM-447.
5. Multipurpose Grease (B0400852) on thread and rubber O-seal ring; joint must be leakproof.
6. Tapered roller bearing prescribed adjustment (differential).
7. Axle shafts in transmission — see "Axle Shaft Seal Rings, Replace" Page 30.
8. Check transmission fluid level

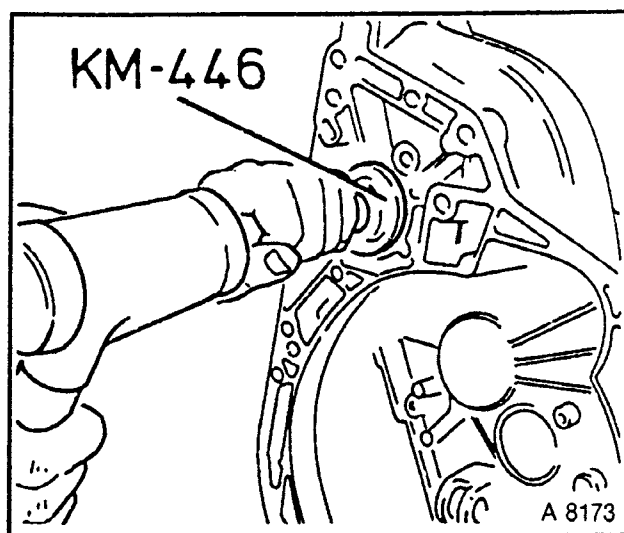


Fig. 110

**Differential — Assemble and Install**

F16, F20

**ASSEMBLE**

F 16:

1. Axle shaft and differential bevel gears, belleville spring washers or flat friction washers and bevel gear axle in differential housing.
2. Centre differential bevel gears and friction washers — KM-160-4.

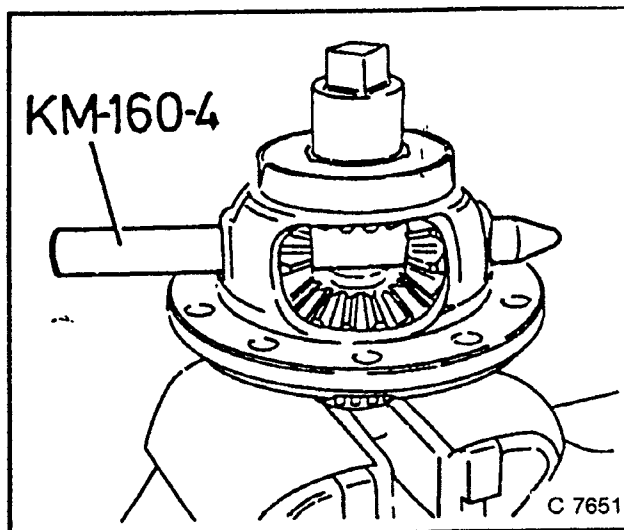


Fig. 111

## ASSEMBLE

### F20:

- 1 Clamp differential housing in vice with soft protective jaws.
- 2 Re-finish lateral inner edges of installation aperture using a round file, to assist in the installation of friction washers.
- 3 Grind an open ended wrench, size 13, to narrow it on both sides, in order to be able to release pre-tension of the axle shaft gears after installing differential gears.

## INSTALL, CONNECT

- 1 Axle shaft gears with Belleville spring washers and friction washers, differential gears with friction washers in differential housing.
- 2 Insert axle shaft gears, pre-tension using KM-670 until differential gears can be inserted with friction washers in splines and screwed in.

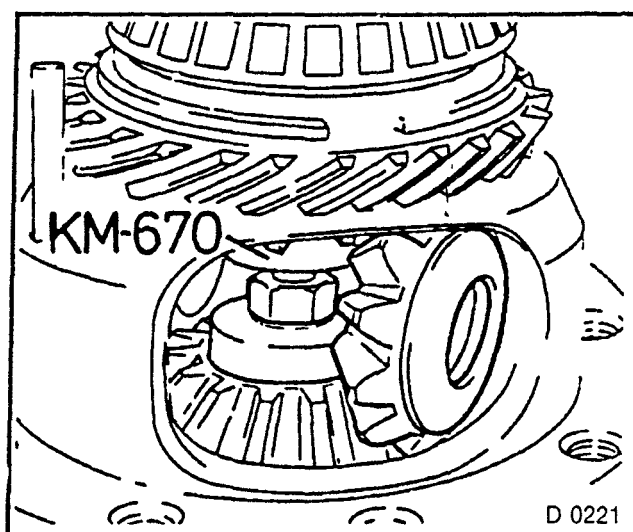


Fig. 112

## REMOVE, DISCONNECT

1. KM-670 — with narrow-ground open ended wrench size 13.
2. Centre differential bevel gears and friction washers, KM-160-4.

## INSTALL, CONNECT

1. Bevel gear axle — **DO NOT** yet pin.

## ADJUST

1. Pre-tensioning of axle shaft gears.
2. Measure complete spin torque for installation without play (no play in tooth profile) — KM-J-28544, MKM-536.
3. Select friction washers of axle shaft gears so that spin torque is 8 to 15 Nm.

Available washer thicknesses: 0.82 mm, 0.88 mm, 0.92 mm.

4. After adjustment, pin bevel gear axle and secure by corner — punch on edge of bore hole.

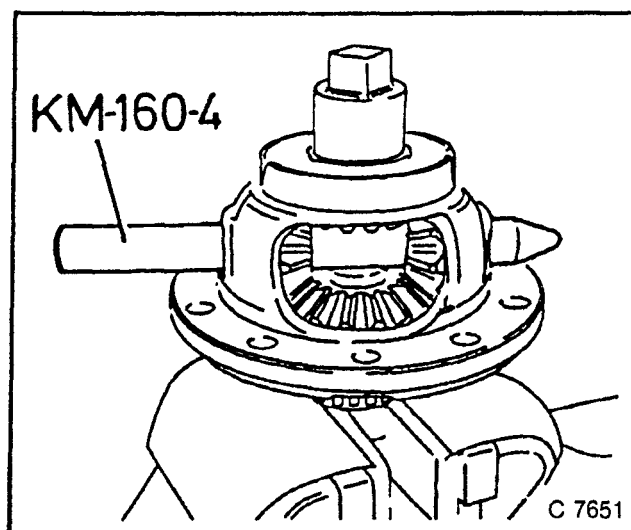


Fig. 113



**F 16 AND F 20****INSTALL, CONNECT**

1. Tension differential housing in vice, KM-524-A.
2. New speedometer helical gear (driving) on differential housing, KM-525.
3. Heat helical gear and KM-525 to approximately 80°C/176°F (water bath, suitable temperature gauge).
4. Cams of helical gear must align with recesses in housing.
5. Grease splines: Anti-friction Bearing Grease (B0400852).

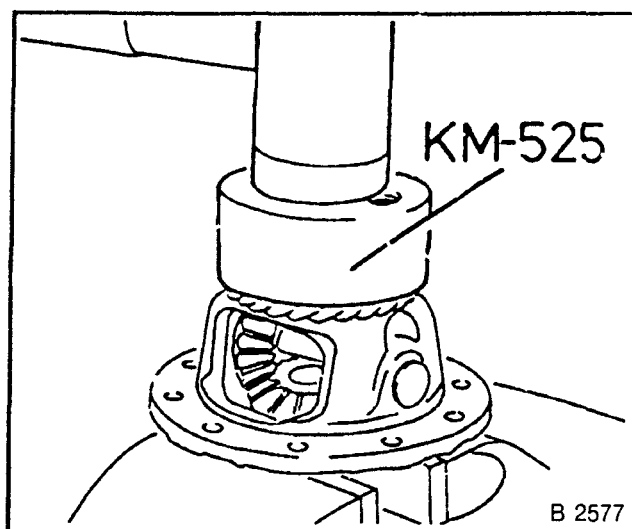


Fig. 114

**TORQUE — ANGLE METHOD**

1. Drive gear with new bolts to differential housing, 70 Nm plus 30° to 45°.
2. Heat drive gear to 80°C/176°F (check temperature with thermocolour pencils, if available or suitable temperature gauge).

**NOTE:**

1. Always replace drive gear (driving drive gear and main shaft) in pairs.
2. Observe circular grooved identification — Technical Data.
3. Both tapered roller bearing inner rings to differential housing. KM-522 (x2).

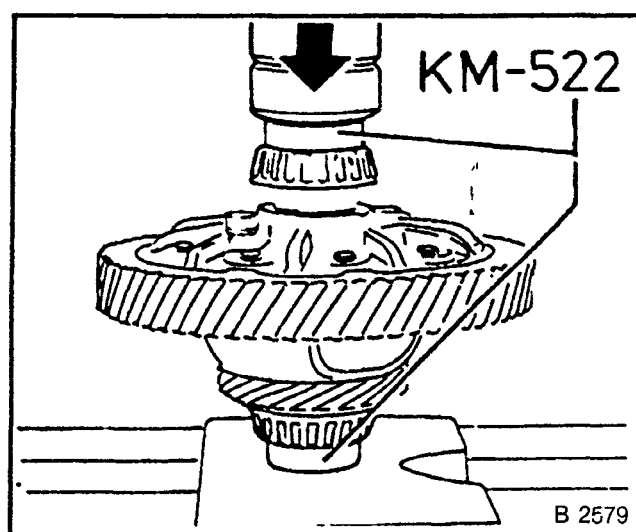


Fig 115

**INSTALL, CONNECT**

1. Each tapered roller bearing outer race in bearing flange or bearing ring, KM-305, KM-451.
2. Drive in seal rings for axle shafts onto bearing ring or bearing flange flush — KM-519; dust lip points inwards; coat sealing lips with Multipurpose Grease (B0400852).
3. Differential in transmission (second mechanic).

**TIGHTEN (TORQUE)**

1. Bearing flange to transmission, 25 Nm.

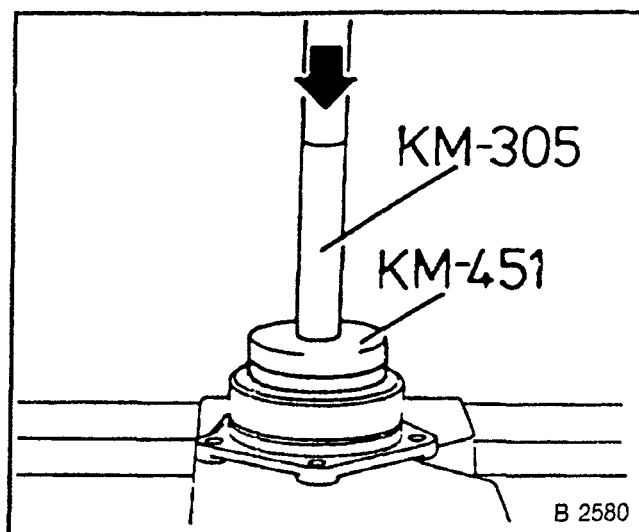


Fig. 116

**INSTALL, CONNECT**

1. Bearing ring on transmission, KM-520.
2. Differential tapered roller bearing prescribed adjustment.
3. Multipurpose Grease (B0400852) on thread and rubber O-seal rings; joint must be leakproof.
4. Axle shafts — see “Axle Shaft Seal Rings, Replace”.
5. Check transmission fluid level.

**Tapered Roller Bearing (Differential) — Prescribed Adjustment****ADJUST**

1. Bearing pre-tensioning by screwing in bearing ring.  
At checking speed of one revolution per second keep to specified spin torques.

F 10, F 13: Torsiometer MKM-536 with KM-455 (see “Special Tools”)

F 16, F 20: Torsiometer MKM-536 with KM-J-28544 (see “Special Tools”)

**Repair case****Transmission removed  
Spin torque (Ncm)****Transmission installed  
Spin torque (Ncm)**

- 1). Adjustment after marking (without axial play)  
Reuse of all parts removed
- 2). Adjustment after marking (with axial play)  
Reuse of all parts removed
- 3) Reuse of bearings  
Replacement of bearing ring, bearing flange,  
differential or transmission housing
- 4) Bearing as new part

Place bearing ring  
at position marked

60 to 100

60 to 100

150 to 210

Place bearing ring  
at position marked

Total spin torque  
plus 80\*

60 to 100

150 to 210

\* In repair case 2) with transmission installed; place bearing ring at position marked, measure total spin torque (with transmission gear set) and then adjust to value given.

In all other repair cases, carry out measurement without transmission gear set (end shield removed).

**TIGHTEN (TORQUE)**

1. Bolts for locking plate of bearing ring to transmission housing, 9 Nm.

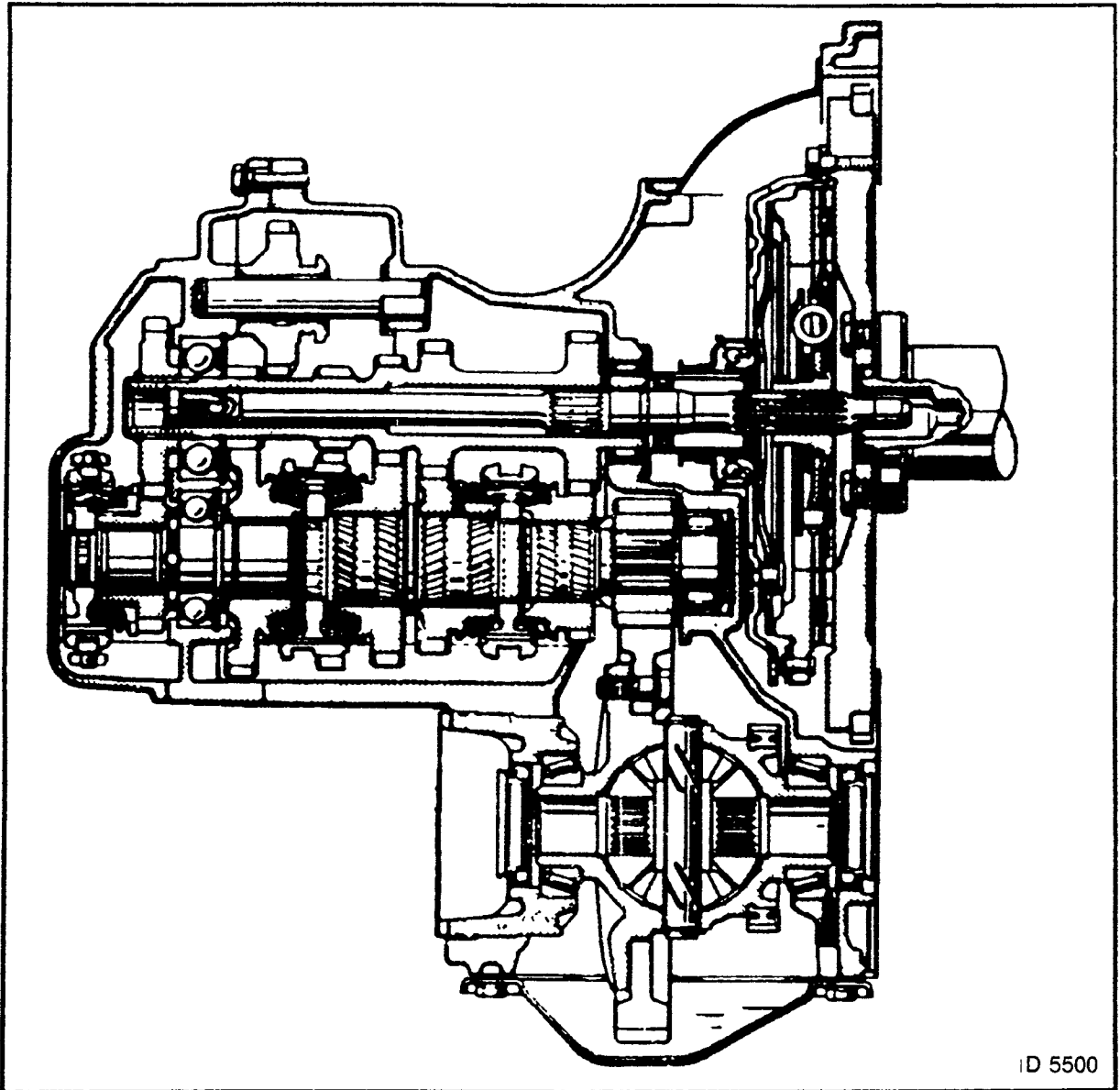
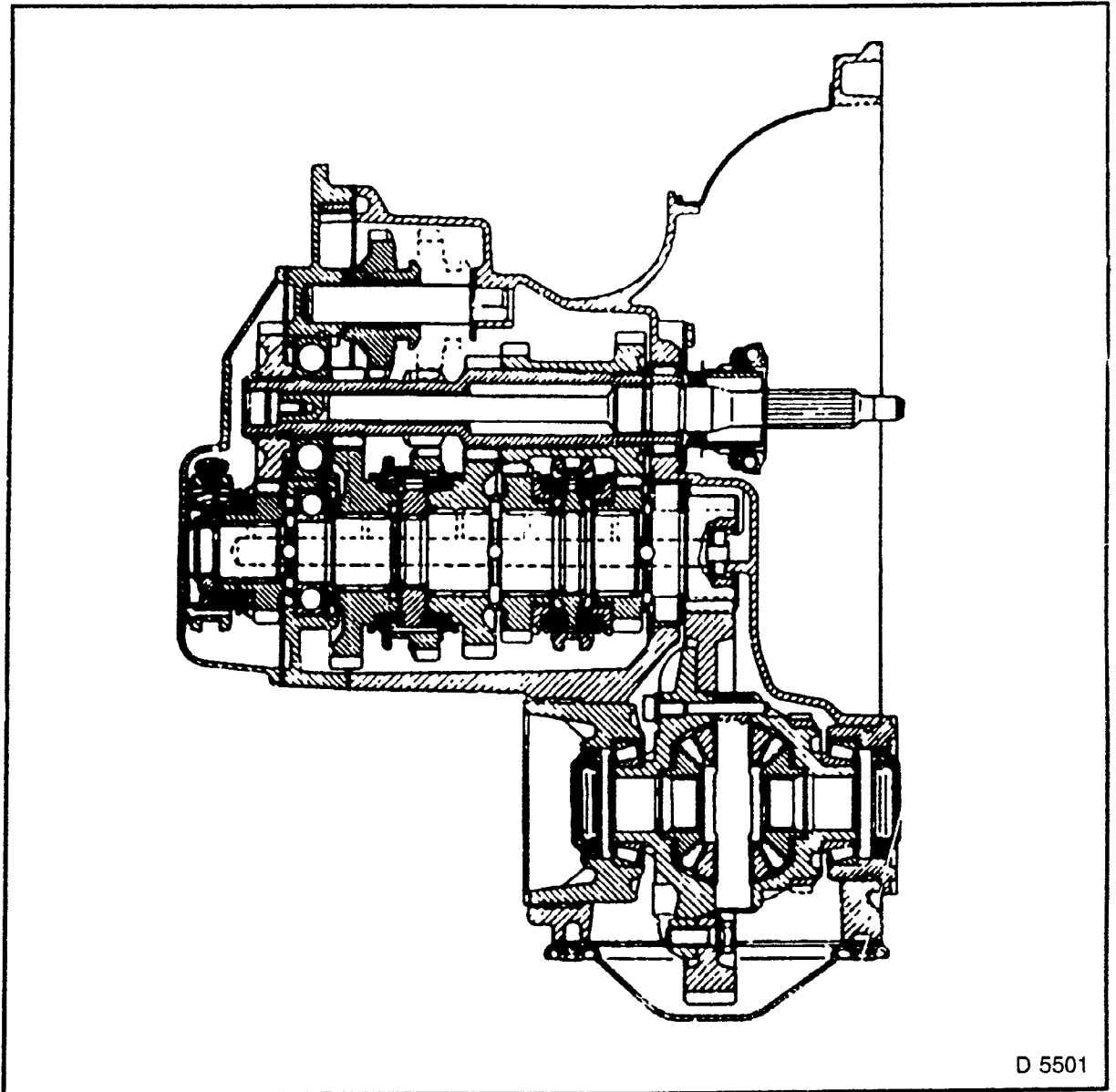


Fig. 117 — F 10/5, F 13/5 Manual Transmission



D 5501

Fig. 118 — F 16/5 Manual Transmission

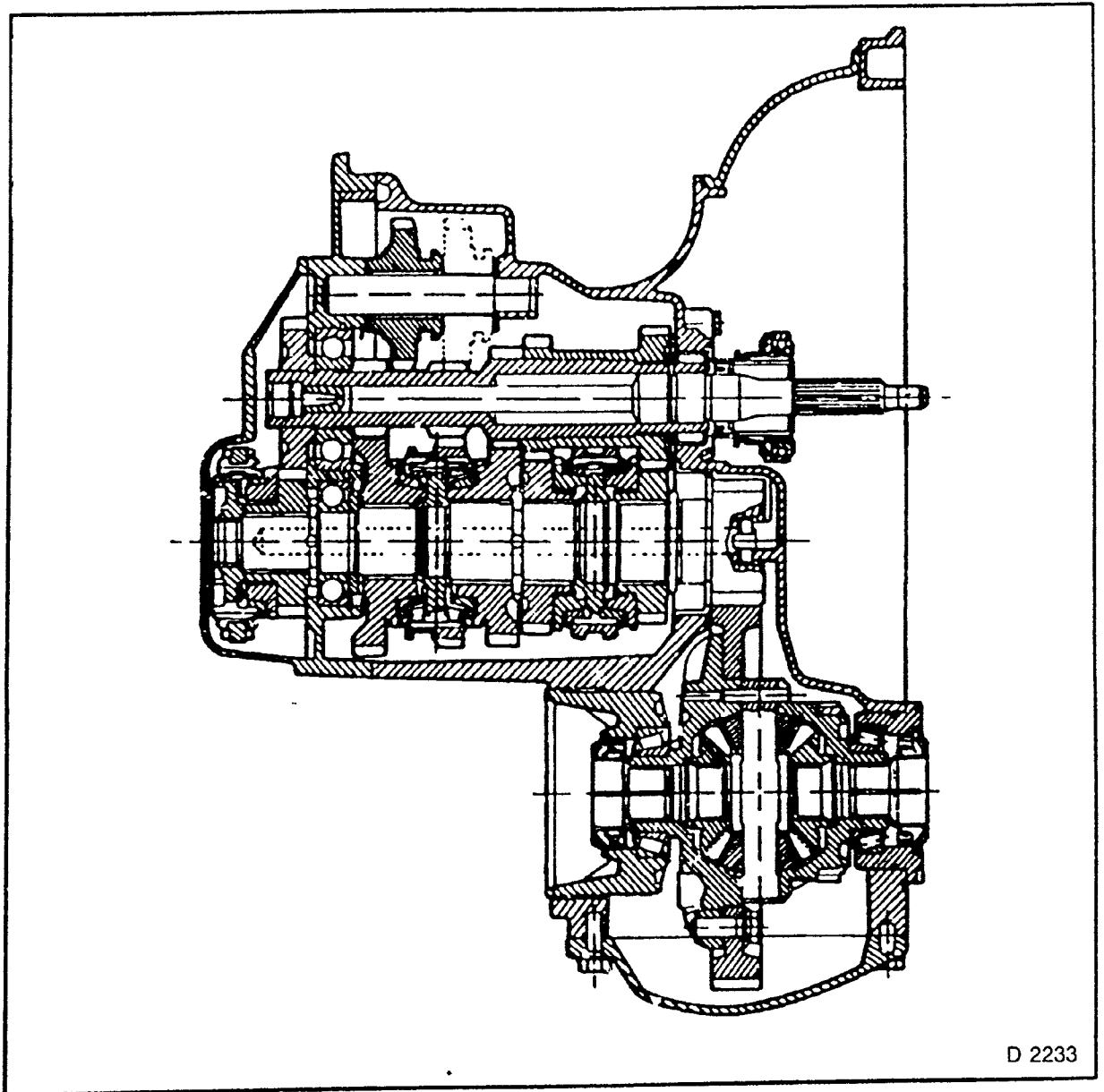


Fig. 119 — F 20/5 Manual Transmission.

## MANUAL TRANSMISSION — OVERHAUL

### End Shield with Main Shaft and Drive Shaft — Remove and Disassemble

**NOTE:**

If operations are planned on the synchronizer rings or gears only, they can be carried out with installed transmission, by removing the end shield.

See operations “Sealing Operations on Installed Transmission” and “Synchroizer Rings, Replace” Page 30 and 86.

#### REMOVE, DISCONNECT

1. Transmission.
2. Fasten transmission to transmission support using Transmission Holder KM-444-B in conjunction with Base KM-489.

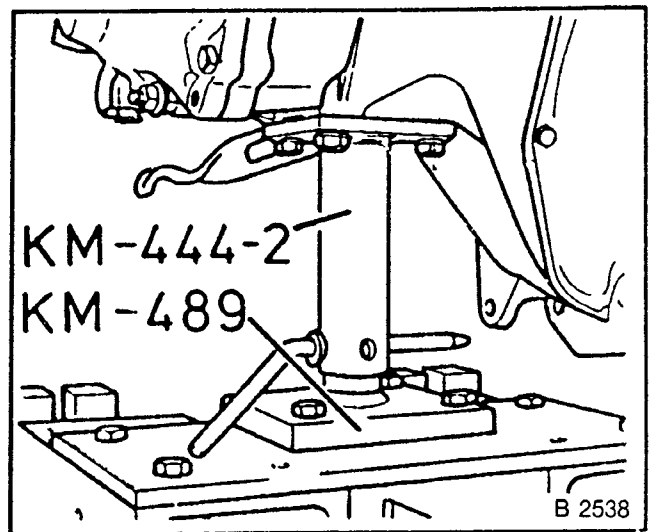


Fig 120

**REMOVE, DISCONNECT**

1. Shift cover from transmission.
2. End shield cover.

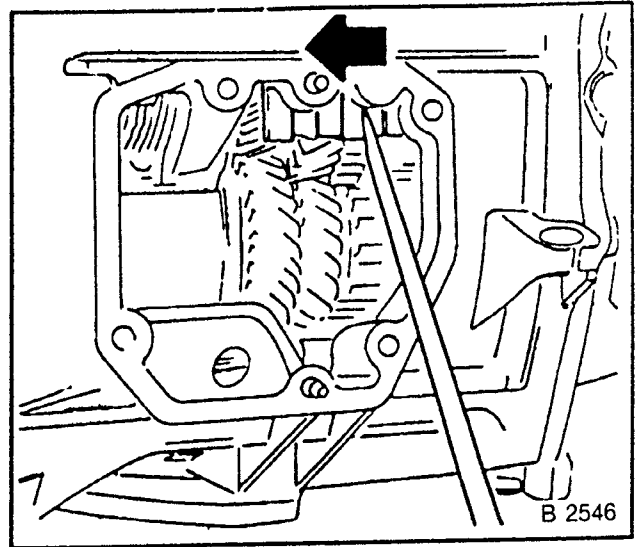


Fig. 121

3. Reversing lamps switch.

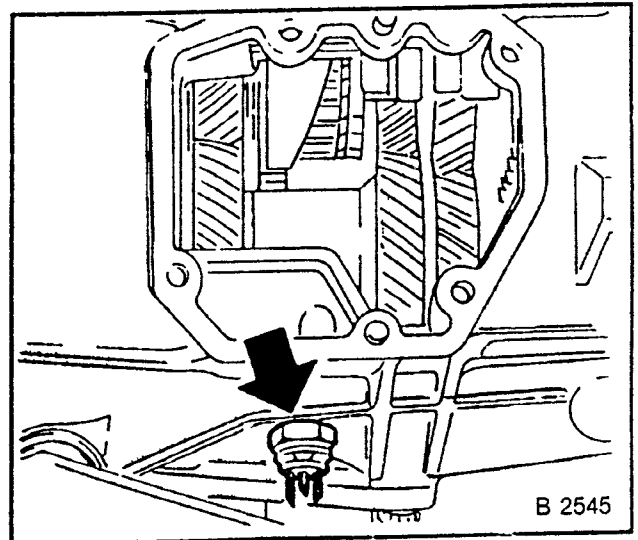


Fig. 122

**REMOVE, DISCONNECT**

1. End shield assembly from transmission.  
Note that magnets are released.  
Fig. 123 shows removed transmission.

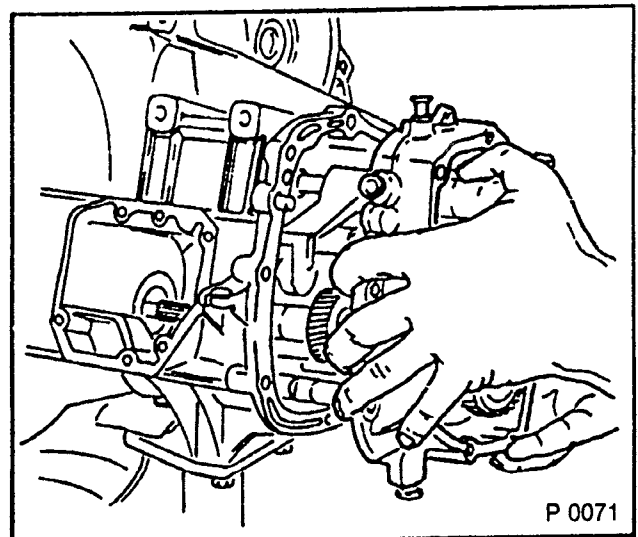


Fig. 123

- Secure end shield to transmission stand, KM-552, KM-113-2.

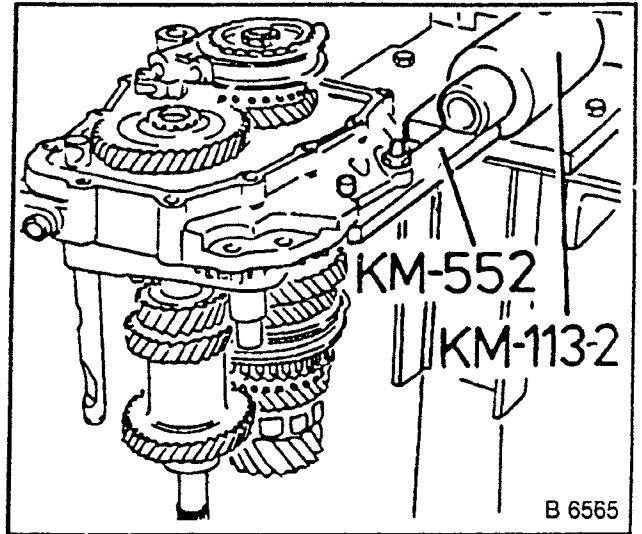


Fig 124

### REMOVE, DISCONNECT

- Bearing support with rocker arm from end shield (arrows).

#### NOTE:

**Micro-encapsulated bolts.**

If stiff, heat end shield with hot-air dryer to approximately 80°C/176°F. (Check temperature with thermo-colour pencils if available, or use suitable temperature gauge).

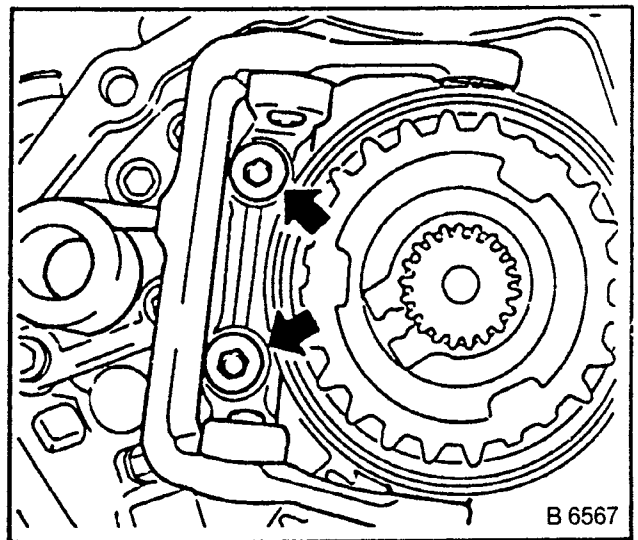


Fig 125

### REMOVE, DISCONNECT

- Retaining ring in front of synchromesh body from main shaft 5th gear synchromesh body from main shaft, KM-161-A, KM-161-2 or KM-553-A.
- Engage two gears simultaneously (e.g. 3rd and reverse).

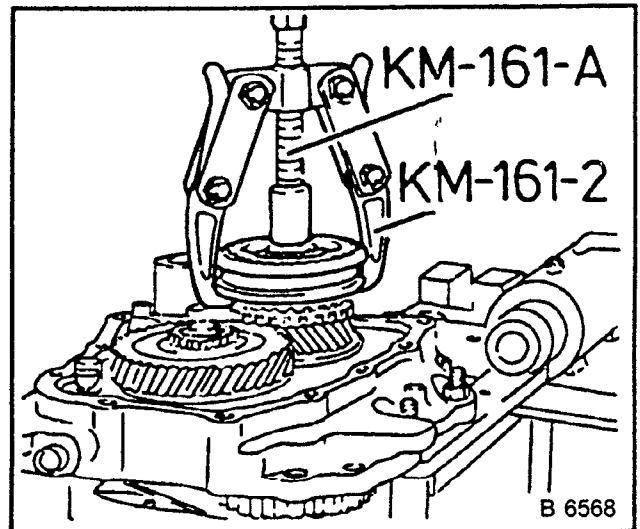


Fig 126



**REMOVE, DISCONNECT**

1. 5th gear (driven).
2. Needle bearing for 5th gear.
3. Needle bearing (for F 16/5 in two parts) is slotted, bend up slightly.
4. Retaining ring for thrust washer.
5. Thrust washer halves from main shaft.

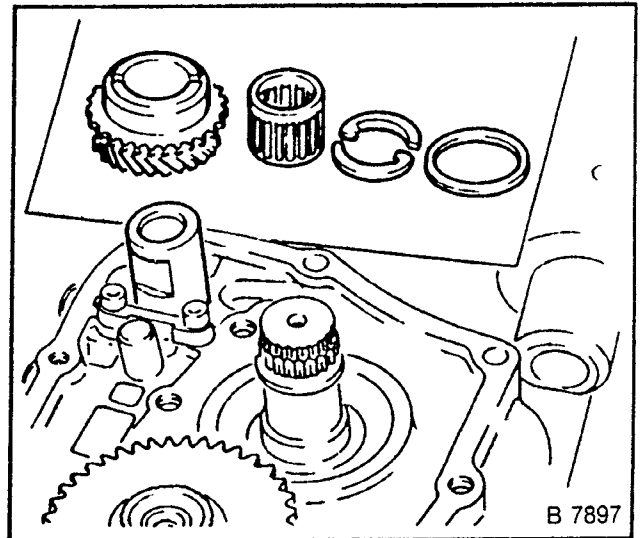


Fig 127

6. Retaining ring of gear from gear cluster.
7. Remove retaining ring of 5th gear (driving) from gear cluster, KM-553-A.
8. Place pressure piece on gear cluster; **do not** support pressure piece on the driving shaft on the gear cluster.

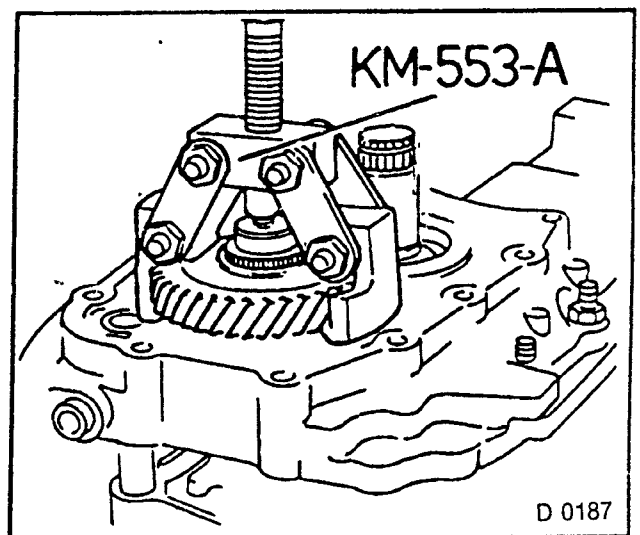


Fig. 128

**REMOVE, DISCONNECT**

1. Bearing support with pawl from end shield.  
To replace pawl, press out pin from bearing support.

**NOTE:**  
Micro-encapsulated bolts.  
If stiff, heat end shield with hot-air dryer.

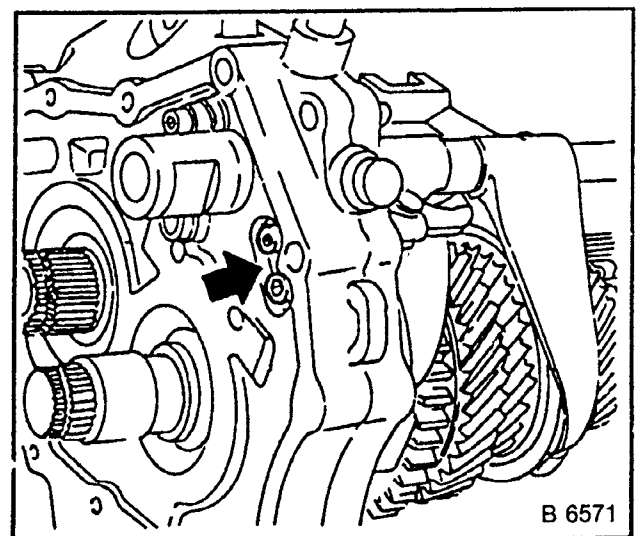


Fig. 129

**REMOVE, DISCONNECT**

- 1 Plugs for switch catch from end shield, KM-727, KM-328-B  
One long plug (1)  
Three short plugs (2)

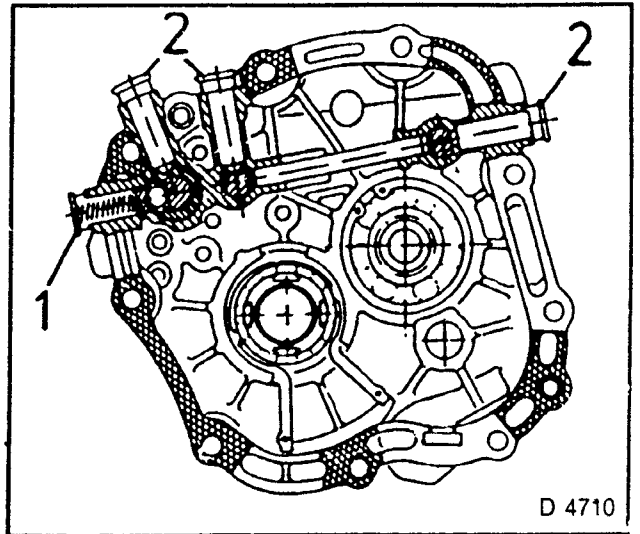


Fig 130

**REMOVE, DISCONNECT**

1. Unbolt bridge for pawl from end shield (large arrows).

**NOTE:**

**Micro-encapsulated bolts.**  
If stiff, heat end shield with hot-air dryer to approximately 80°C/176°F (check temperature with thermo-colour pencils if available, or use suitable temperature gauge).

Engage 2nd and 5th gears (with shift driver).

If 3rd gear is now engaged, the bridge will be pushed out.

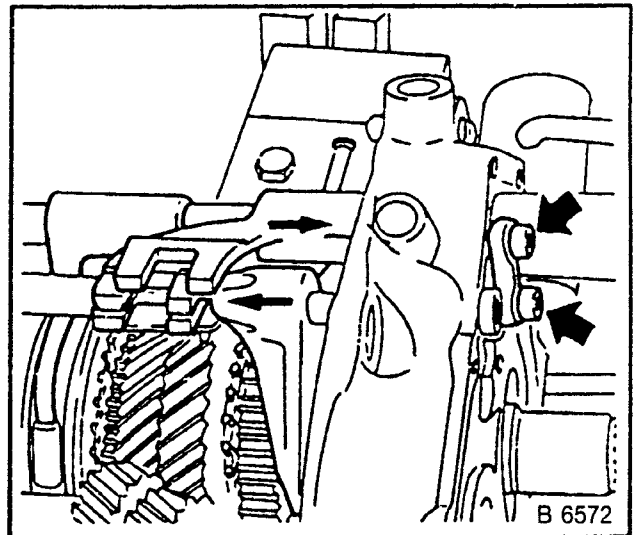


Fig 131

**REMOVE, DISCONNECT**

1. Pins from 3rd and 4th gear shift fork and also from reverse gear shift fork — punch
2. Release pressure on rod guide, support shift rod at top with wood.

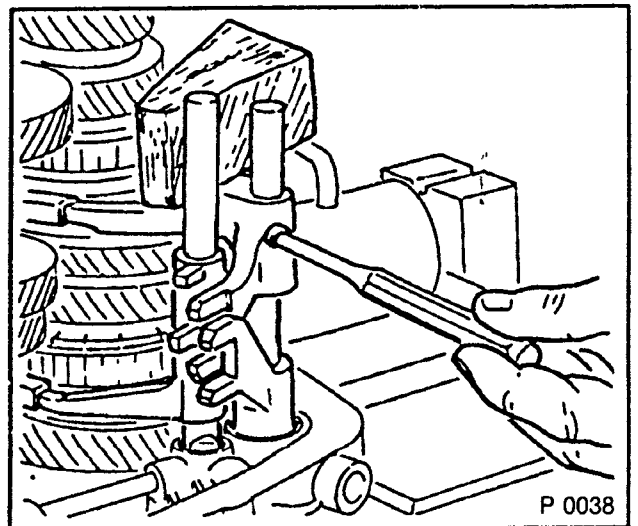


Fig. 132

**REMOVE, DISCONNECT**

- 1 3rd and 4th gear shift rods and shift forks.
2. Reverse gear from end shield.
3. 5th gear shift driver from end shield.
4. Shift sleeve in neutral position.

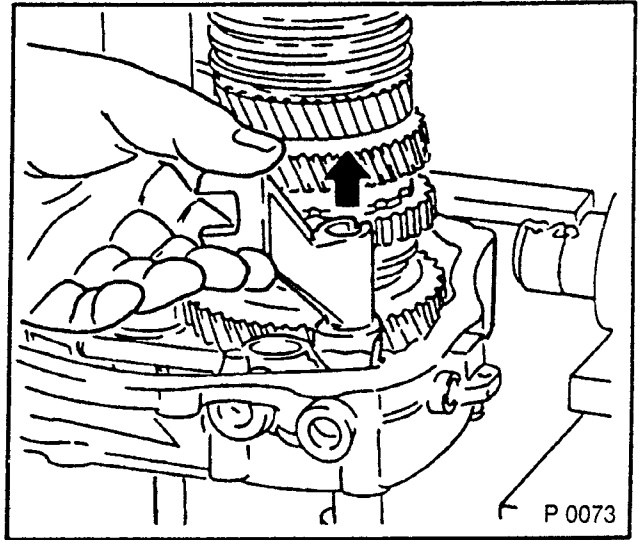


Fig. 133

**REMOVE, DISCONNECT**

1. Locking pin for catch from end shield bore holes.

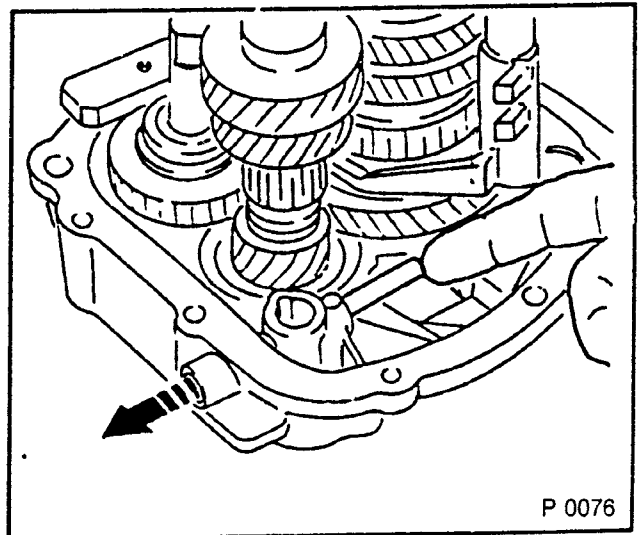


Fig. 134

**F 10/5, F 13/5 MANUAL TRANSMISSION:****REMOVE, DISCONNECT**

1. Remove retaining rings from grooves in end shield, KM-443-A. As assembly aid, tension retaining ring for main shaft with installation plate (A). Measurements for own construction, see Fig. 137.

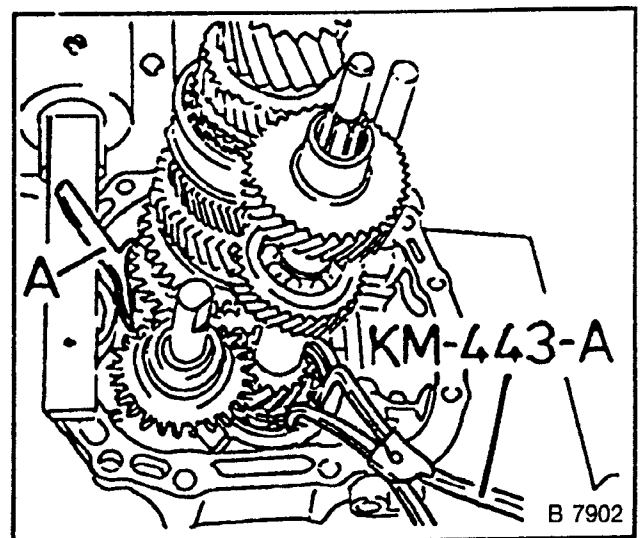


Fig. 135

**F 16/5, F 20 MANUAL TRANSMISSION:**

Press retaining ring for bearing main shaft together with ring pliers (KM-443-B) and hold under tension with mounting plate (A). **Simultaneously** press apart retaining ring (B) for bearing of gear cluster with flat ring pliers (second mechanic).

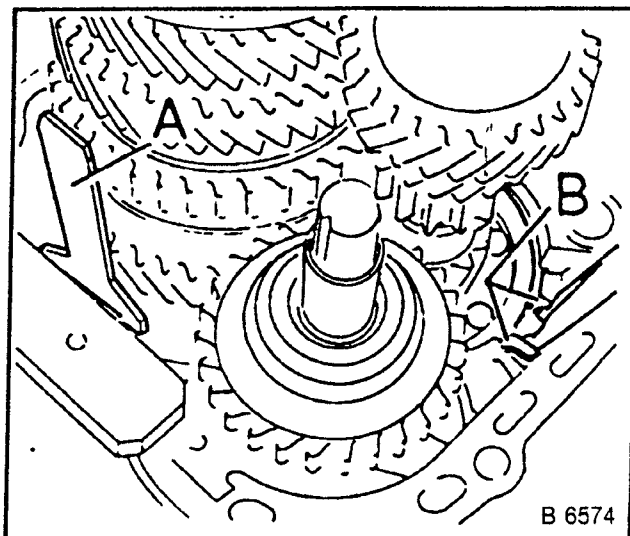


Fig. 136

Prepare installation plate according to the dimensions on right.

Tool KM-443-B contains ring pliers and mounting plate.

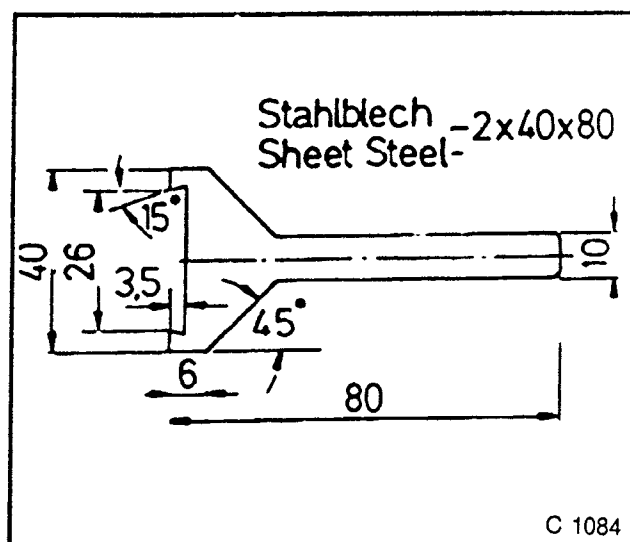


Fig. 137

**ON ALL TRANSMISSIONS:****REMOVE, DISCONNECT**

1. Pull out main shaft.
2. Drive shaft.
3. Reverse idler gear.
4. Shift fork.
5. Shift rod 1st and 2nd gear from end shield.

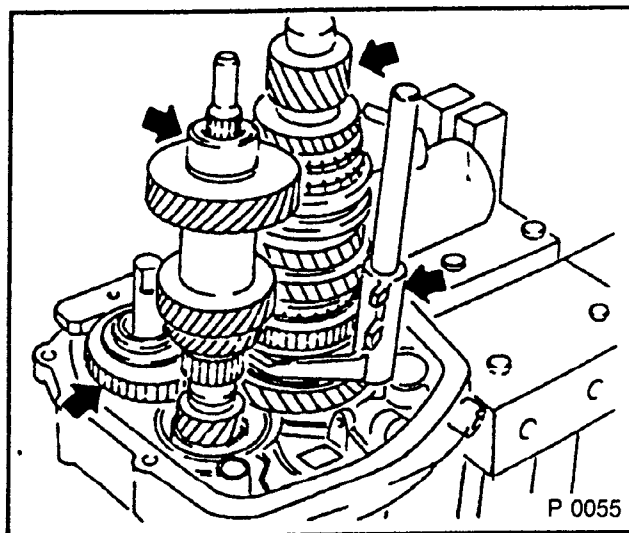


Fig. 138

**REMOVE, DISCONNECT**

- 1 Reverse idler gear axle from end shield.
- 2 Clamp axle between protective jaws in vice.
- 3 Knock off end shield carefully, brass punch.
4. Note locking ball

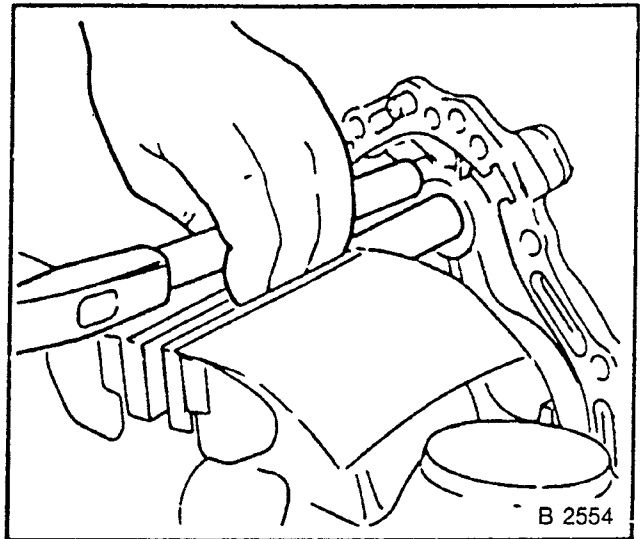


Fig. 139

**Drive Shaft —  
Disassemble**

**NOTE:**  
IF GEAR CLUSTER TEETH ARE  
DAMAGED, ALWAYS REPLACE  
CORRESPONDING GEAR ON THE  
MAIN SHAFT AS WELL.

**REMOVE, DISCONNECT**

1. Press drive shaft out of gear cluster with suitable drift (arrow).

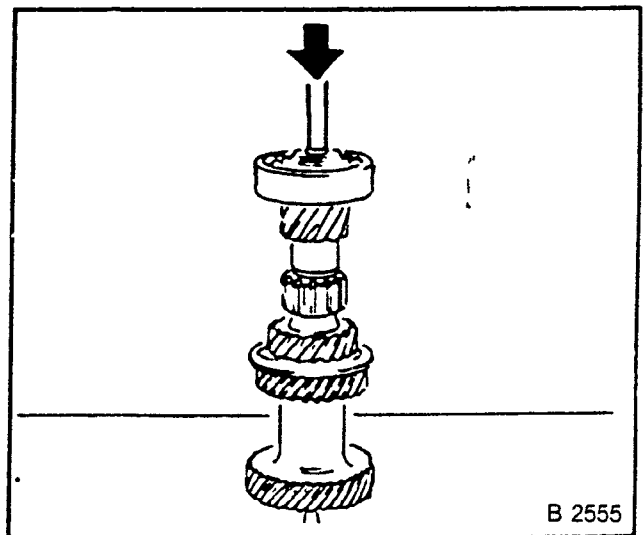


Fig 140

**REMOVE, DISCONNECT**

1. Press ball bearing off from gear cluster.  
F 10, F 13 with suitable pipe.  
(Remove retaining ring and washer)
- F 16, F 20 with KM-407-A  
(Remove retaining ring)

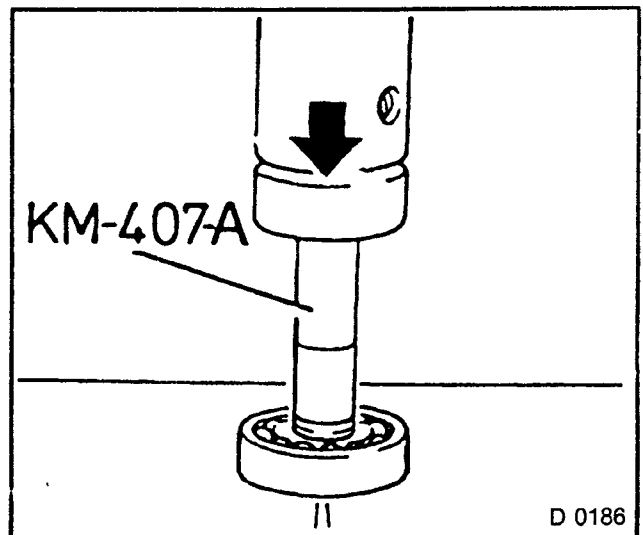


Fig. 141

## Main Shaft — Disassemble

### F10, F 13 MANUAL TRANSMISSION:

If gear wheels are damaged, always replace gear cluster as well.

### DISASSEMBLE

- 1 Retaining ring on front of ball bearing.
- 2 Press off ball bearing, retaining ring (long leg), spacing washer, axial needle bearing and 1st gear with suitable drift.
3. Remove needle bearing for 1st gear from main shaft.
4. Remove three synchronizer rings (1st gear), shift sleeve and sliding blocks.
5. Remove retaining ring for 1st/2nd gear synchromesh body.
6. Press off 1st/2nd gear synchromesh body, three synchronizer rings (2nd gear) and 2nd gear with suitable drift, KM-307-B.

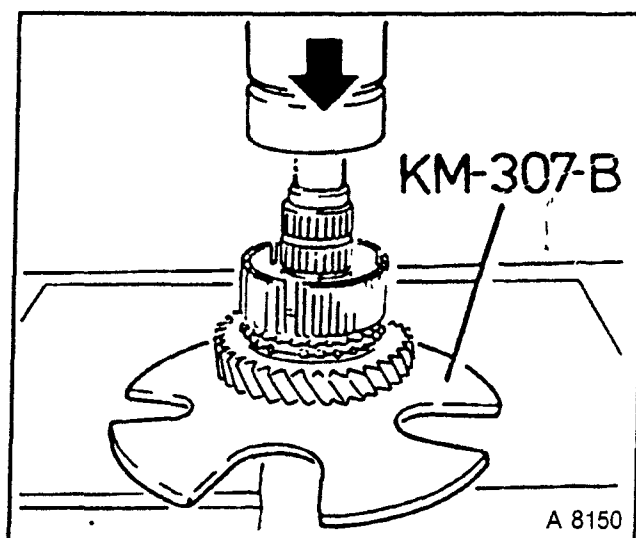


Fig. 142

### REMOVE, DISCONNECT

1. Retaining ring for drive gear (driving) from main shaft.
- 2 Press drive gear (driving) off from main shaft, KM-307-B and suitable drift.

**NOTE:**  
**ALWAYS REPLACE DRIVE GEARS**  
**(DRIVING AND DRIVEN) IN PAIRS.**

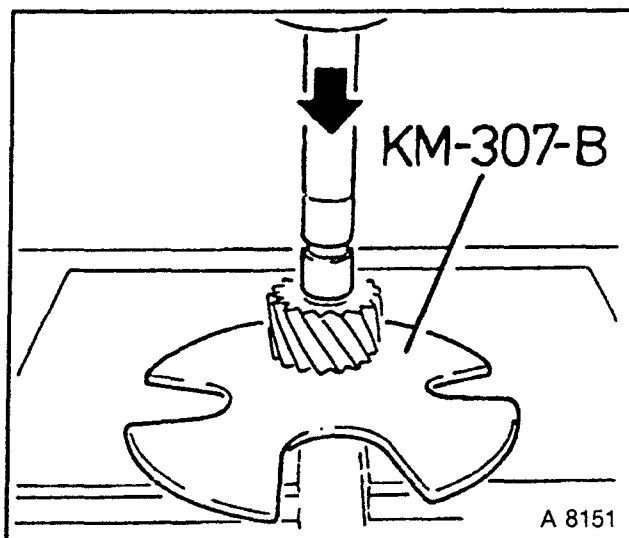


Fig. 143

**REMOVE, DISCONNECT**

1. Press off spacing washer and also 4th gear, KM-479-A.
2. Place KM-479-A in groove of 4th gear.

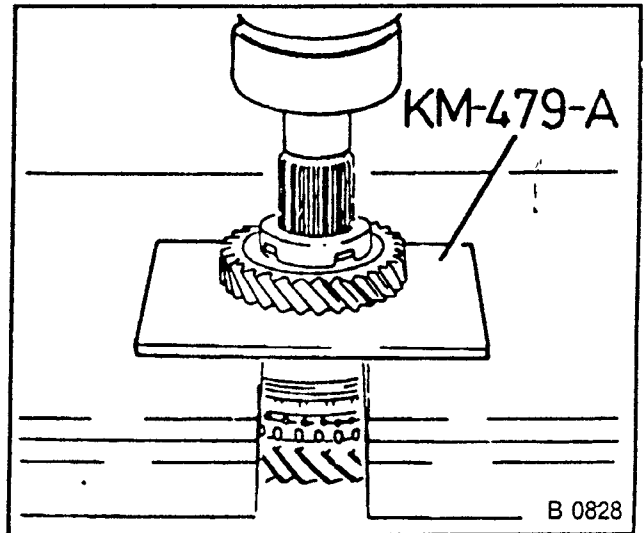


Fig. 144

**REMOVE, DISCONNECT**

1. Remove synchronizer ring (4th gear), shift sleeve and sliding blocks.
2. Retaining ring for 3rd/4th synchromesh body.
3. Press off 3rd/4th gear synchromesh body and 3rd gear with suitable drift.

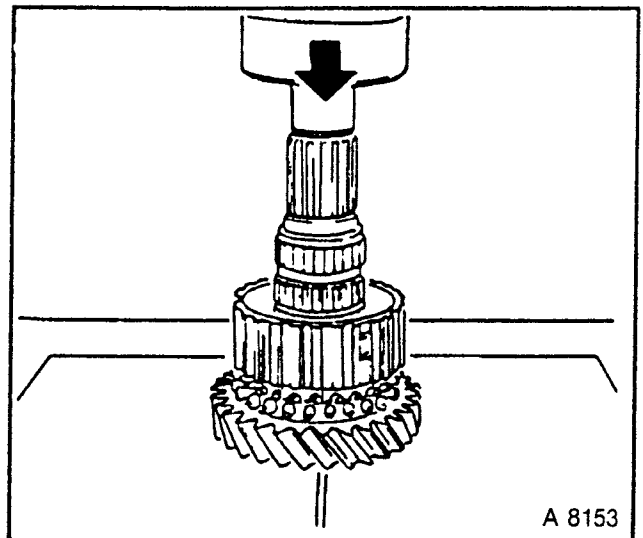


Fig. 145

**Main Shaft —  
Disassemble****F 16, F 20 MANUAL TRANSMISSION:**

If gear wheels are damaged, always replace gear cluster as well.

**DISASSEMBLE**

1. Remove retaining ring from ball bearing.
2. Press off ball bearing, retaining ring (long leg), spacer washer, axial needle bearing and 1st gear from main shaft with suitable drift.
3. Place KM-307-B or two L-bars under gear.
4. Needle bearing for 1st gear from main shaft.

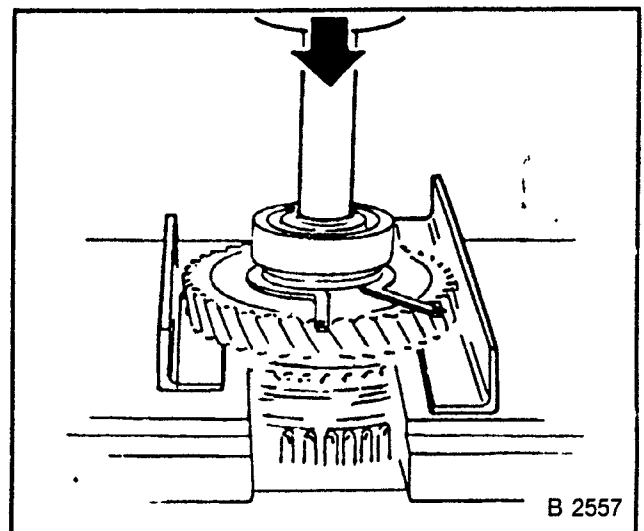


Fig. 146

**REMOVE, DISCONNECT**

1. Retaining ring for 1st/2nd gear synchromesh body.
2. Synchromesh body and also 2nd gear.
3. To press off, use KM-307-B or place two L-bars under 2nd gear
4. Needle bearing for 2nd gear from main shaft.

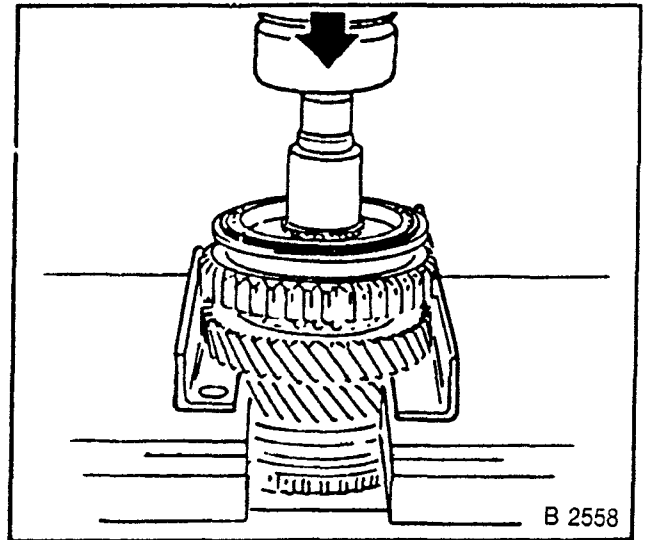


Fig. 147

5. Retaining ring for thrust washer.
6. Thrust washer halves.
7. 3rd gear from main shaft.
8. Needle bearing is slotted, bend up slightly.
9. Retaining ring and washer in front of 3rd/4th gear synchromesh body from main shaft.
10. Synchromesh body and also 4th gear from main shaft.
11. To press off, use KM-307-B or place two L-bars under gear.

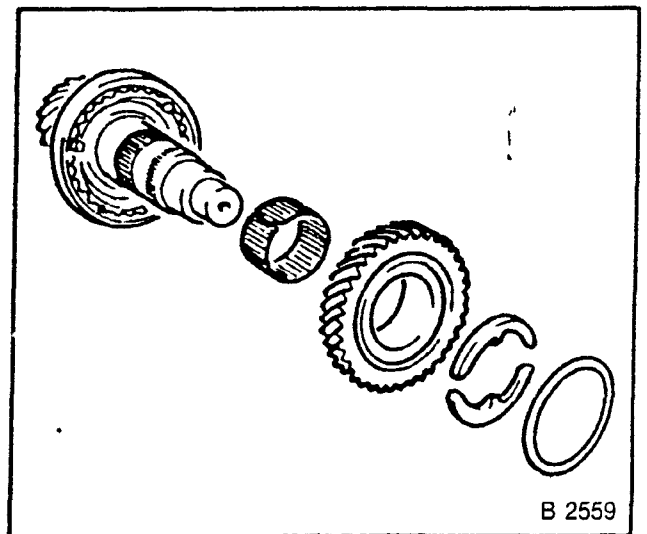


Fig. 148

**F 16 MANUAL TRANSMISSION:****REMOVE, DISCONNECT**

1. Retaining ring for thrust washer.
2. Halves of thrust washer.
3. Slotted needle bearing for 4th gear (bend apart slightly).
4. Roller bearing from main shaft.

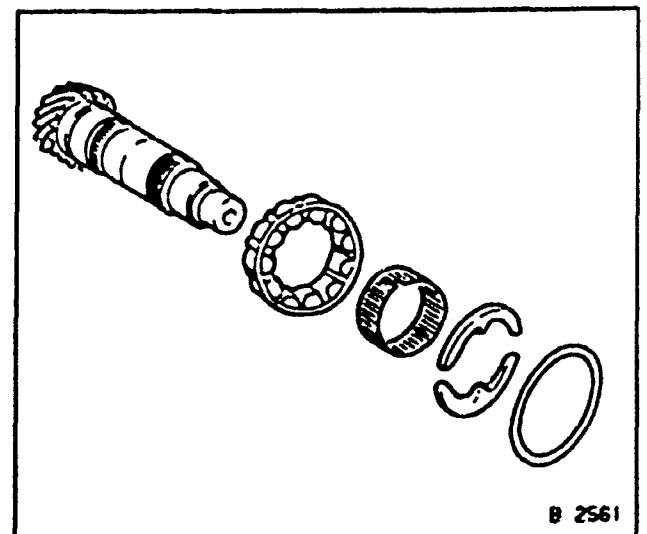


Fig. 149



**F 20 MANUAL TRANSMISSION:**

Needle bearing for 4th gear, roller bearing, needle bearing and roller bearing are slotted (1), bend apart slightly.

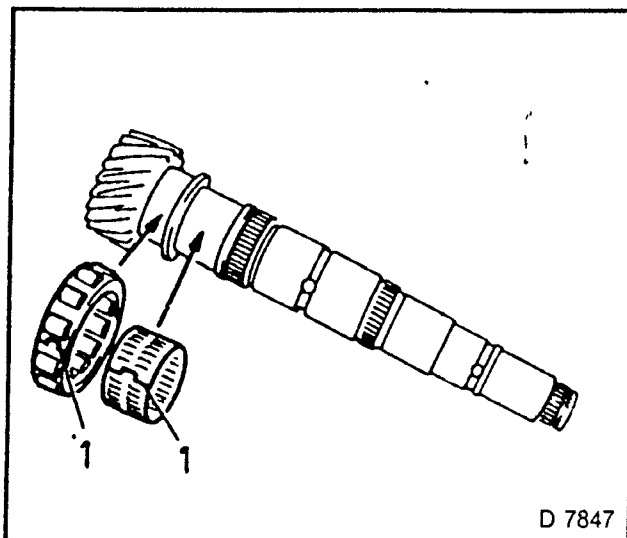


Fig. 150

**F 16 and F 20 MANUAL TRANSMISSION:**

Main shaft and drive gear (driving) are one part and may not be disassembled. Always replace drive gears in pairs. Note groove identification running around tip of tooth — see "Technical Data" Page 263.

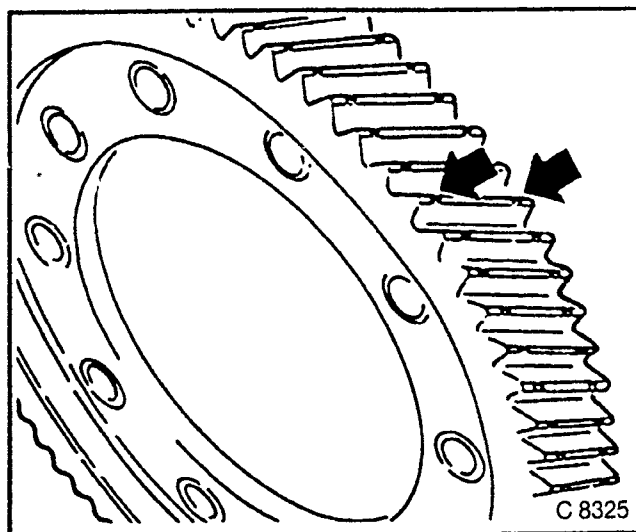


Fig. 151

## Bearing Rings in Transmission Housing — Replace

**F 10, F 13 MANUAL TRANSMISSION:****REMOVE, DISCONNECT**

1. Clutch pressure bearing.
2. Clutch fork from clutch release lever.
3. Clutch release lever from transmission.
4. Clutch pressure bearing guide.
5. Needle sleeve for drive shaft bearing from transmission.

Transmission installed: KM-454-1,  
KM-454-4

Transmission removed: KM-556-A.

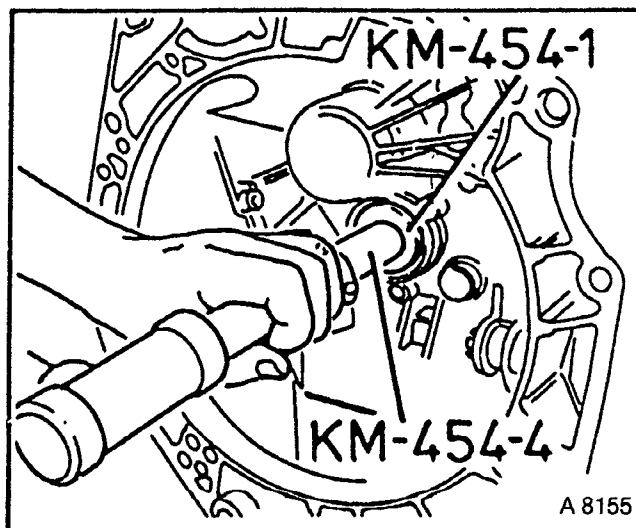


Fig. 152

**REMOVE, DISCONNECT**

1. Differential.
2. Needle sleeve for main shaft bearing from transmission, KM-556-A or Kukko Remover 21/4 with Counterhold 22-1.

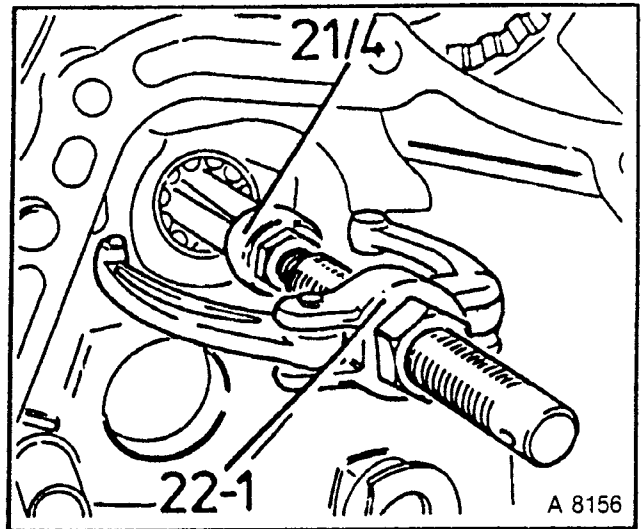


Fig. 153

**INSTALL, CONNECT**

1. Drive in new needle sleeve for main shaft bearing flush, KM-454-3 and KM-454-4.

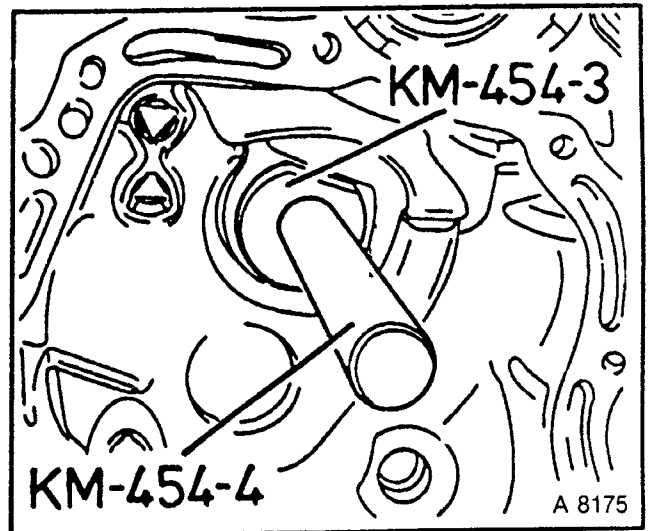


Fig. 154

**INSTALL, CONNECT**

1. Drive in new needle sleeve for drive shaft bearing flush with lettered side to transmission, KM-454-2, KM-454-4.

**TIGHTEN (TORQUE)**

1. Clutch pressure bearing guide to transmission, 5 Nm lubricate sliding surfaces with Molybdenum Disulphate Paste (B0400852).
2. Clutch fork to clutch release lever, 35 Nm.
3. Clutch pressure bearing to clutch fork.

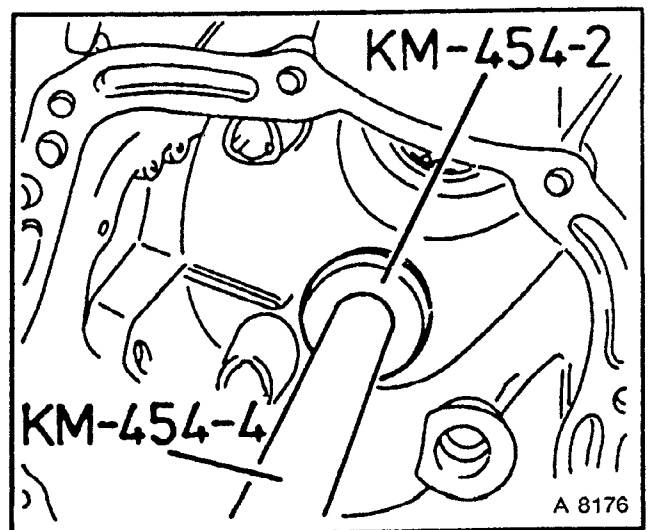


Fig. 155

## Bearing Rings in Transmission Housing — Replace

F 16, F 20 MANUAL TRANSMISSION:

### REMOVE, DISCONNECT

1. Clutch pressure bearing and clutch fork from clutch release lever.
2. Clutch release lever and clutch pressure bearing guide from transmission.
3. Needle sleeve for drive shaft bearing from transmission, KM-523-1, KM-523-3.
4. Outer ring of roller bearing for main shaft bearing, KM-J-26941 (1), KM-483 (2) and KM-313 (3).

If difficult to move, heat transmission housing with hot-air dryer

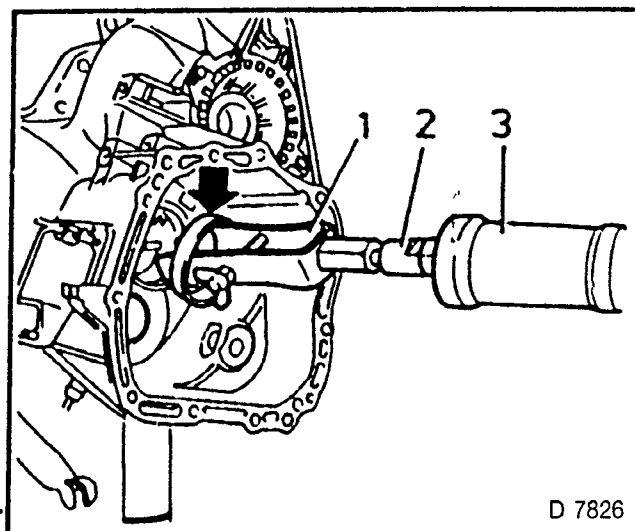


Fig. 156

### INSTALL, CONNECT

- 1 Press on new outer ring for main shaft bearing up to stop.  
(do not drive on), KM-523-1 and KM-523-4.

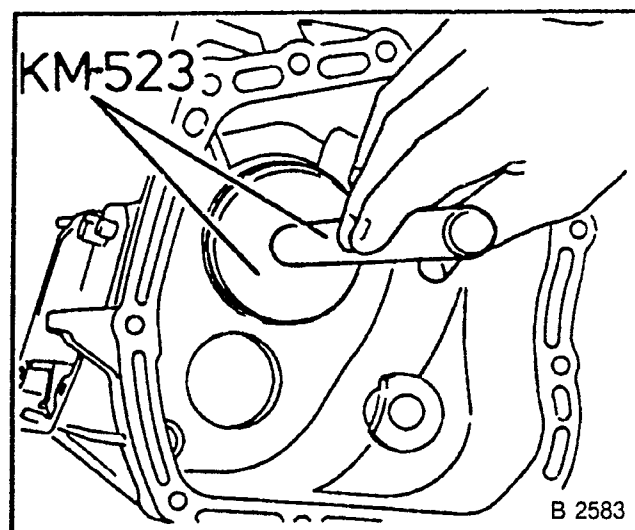


Fig. 157

2. Drive in new needle sleeve for drive shaft bearing flush with lettered side to transmission, KM-523-1, KM-523-2.

### TIGHTEN (TORQUE)

1. Clutch pressure bearing guide to transmission, 5 Nm.
2. Lubricate sliding surfaces with Molybdenum Disulphate Paste (B0400852).
3. Clutch fork to clutch release lever, 35 Nm.
4. Clutch pressure bearing to clutch fork.

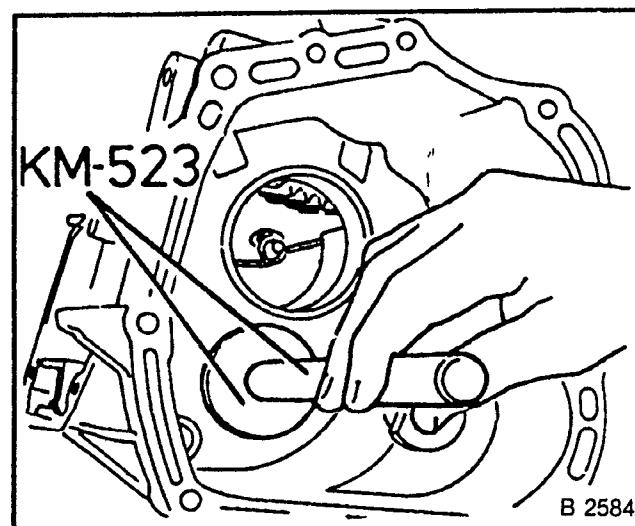


Fig. 158

**CLEAN****INSPECT**

1. Removed parts for damage and wear.
2. Before installing, submerge all parts in Transmission fluid (B0400075).

All transmissions have three cone synchronization for 1st/2nd gear:

- 1 = 2nd gear
- 2 = Inner synchronizer rings
- 3 = intermediate rings
- 4 = outer synchronizer rings
- 5 = shift sleeve
- 6 = synchronizer springs
- 7 = sliding blocks
- 8 = synchronmesh body (carrier)
- 9 = 1st gear

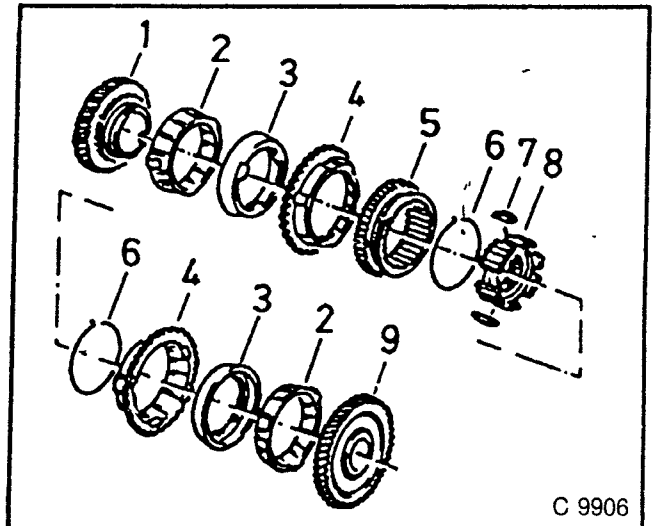


Fig 159

**Main Shaft — Assemble**

F 10, F 13 MANUAL TRANSMISSION:

**ASSEMBLE**

1. Synchronmesh bodies, 1st/2nd gear and also 3rd/4th gear.
2. Attach synchronizer springs in sliding block with their hooks facing opposite directions, so that free end of spring hangs away from synchronmesh body.
3. Insert sliding block into flat middle tooth of sliding sleeve.

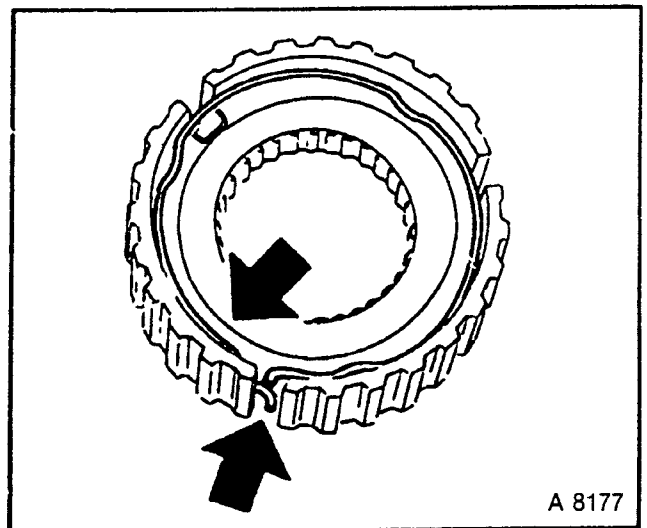


Fig. 160

4. Slide 3rd gear from drive gear side onto main shaft.
5. Lubricate bearing bore hole with Transmission Fluid (B0400075).
6. Place synchronizer ring onto 3rd gear cone.
7. Press on 3rd/4th gear synchromesh body assembly, KM-277.
8. Heat assembly to 100°C/212°F (thermocolour pencils, if available, or use suitable temperature gauge).
9. Lubricate contact surfaces of main shaft with Transmission Fluid (B0400075).
10. New retaining ring.

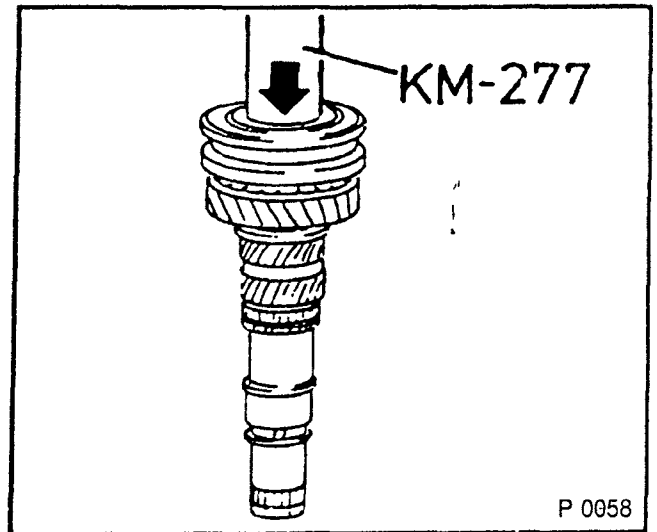


Fig. 161

## INSTALL, CONNECT

1. Slide synchronizer ring and 4th gear onto main shaft.
2. Press spacing washer and drive gear (driving) onto main shaft, KM-311/2.
3. Heat both parts to 100°C/212°F (thermocolour pencils, if available, or use suitable temperature gauge)
4. Lubricate contact surfaces of main shaft with Transmission Fluid (B0400075).
5. Retaining ring in front of drive gear (driving).
6. Grooves on spacing washer point towards gear
7. Always replace drive gears in pairs. Circular groove identification on tip of tooth.
8. Drive gear front surface with collar points towards spacing washer.
9. Lubricate bearing bore holes and seat surfaces of main shaft with Transmission Fluid (B0400075).
10. Push 2nd gear onto main shaft.
11. Place inner synchronizer ring, intermediate ring and outer synchronizer ring on 2nd gear cone so that lugs fit in the recesses on each outer synchronizer ring.
12. Heat synchromesh body assembly to approximately 100°C/212°F, (thermocolour pencils, if present, or use suitable temperature gauge).
13. Push 1st/2nd gear synchromesh body assembly onto main shaft so that groove in shift fork points to ball bearing seat, KM-277.
14. New retaining ring.

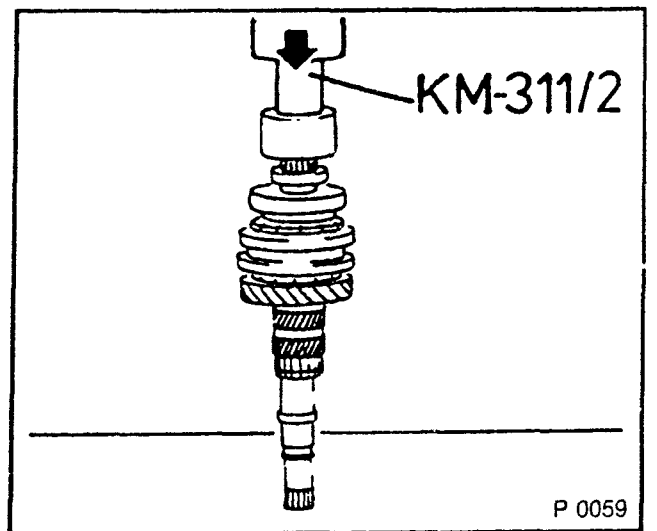


Fig. 162

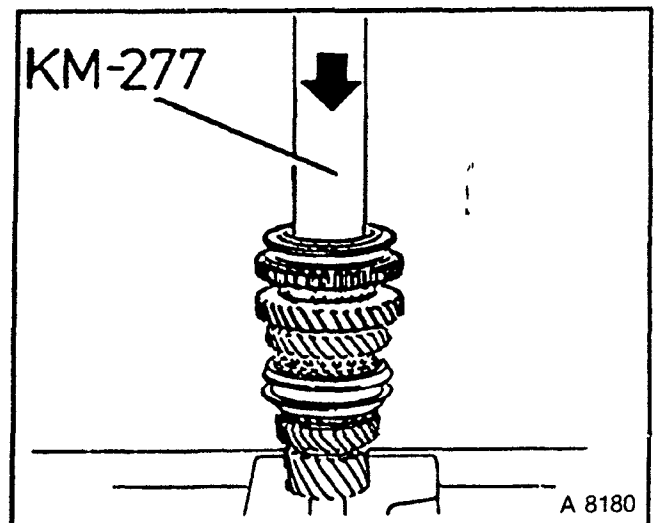


Fig. 163

## INSTALL, CONNECT

1. Place outer synchronizer ring, intermediate ring and inner synchronizer ring on synchromesh body so that the lugs fit in the recesses of each outer synchronizer ring.
2. 1st gear needle bearing on main shaft
3. Push 1st gear onto needle bearing.
4. Place axial needle bearing (arrow) on 1st gear.
5. Lubricate both needle bearings and bearing bore hole of gear with Transmission Fluid (B0400075).

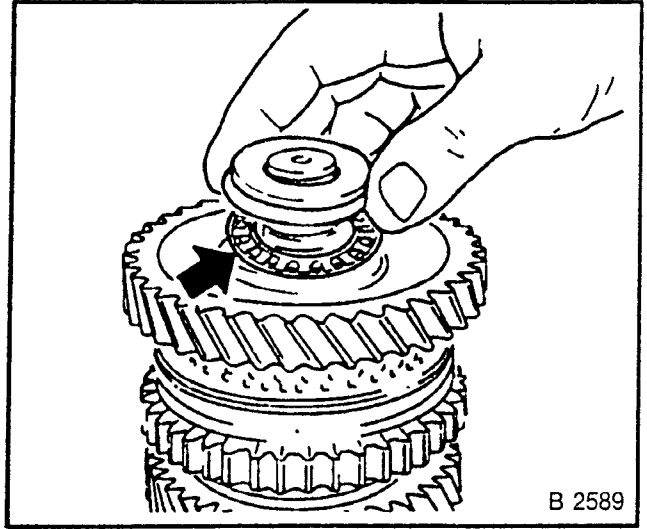


Fig 164

6. Attach new retaining ring with long sides for main shaft to end shield.
7. Press on spacing washer and ball bearing, KM-334.
8. Heat spacing washer to approximately 100°C/212°F, (thermocolour pencils, if present, or use suitable temperature gauge).
9. Grooves on spacing washer point towards gear.
10. Lubricate seating surface of spacing washer on main shaft, Transmission Fluid (B0400075).
11. Secure ball bearings with new retaining ring.
12. Gears for 1st and 5th gears have needle bearings (slotted bearing).

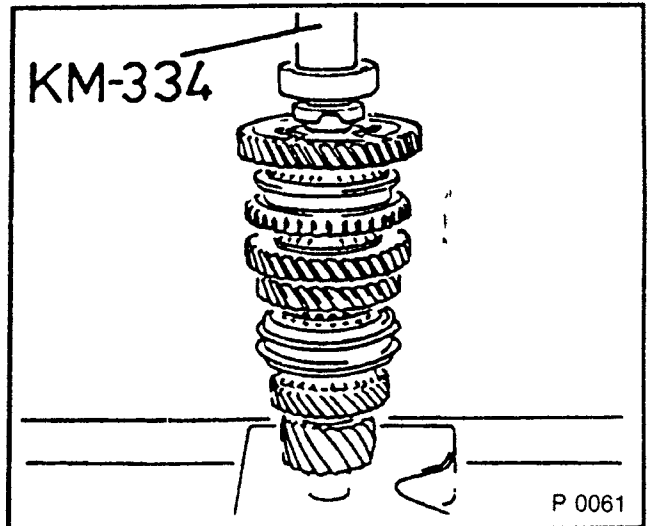


Fig 165

## Main Shaft — Assemble

### F 16, F 20 MANUAL TRANSMISSION:

1. Main shaft with drive gear is one part.
2. Always replace drive gears (driving and driven) in pairs.
3. Observe groove identification running around tip of tooth.
4. Gears, needle bearings, and synchromesh body bodies on the main shaft are set on the shaft in one direction.
5. Assemble 1st/2nd gear and 3rd/4th gear synchromesh bodies.
6. Attach synchronizer springs with their hooks in sliding block facing in opposite directions. Springs are not interlaced.
7. Place sliding block onto flat middle tooth of sliding sleeve.

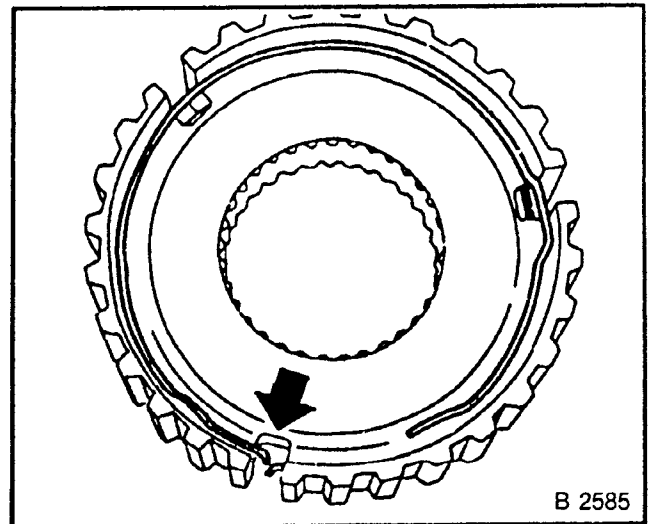


Fig 166

**F 16 MANUAL TRANSMISSION:**

1. Slide roller bearing onto main shaft.
2. Small roller retainer diameter points towards drive gear.
3. Connect thrust washer halves on main shaft with retaining ring.
4. Slide slotted single-row needle bearing onto main shaft and also 4th gear onto needle bearing

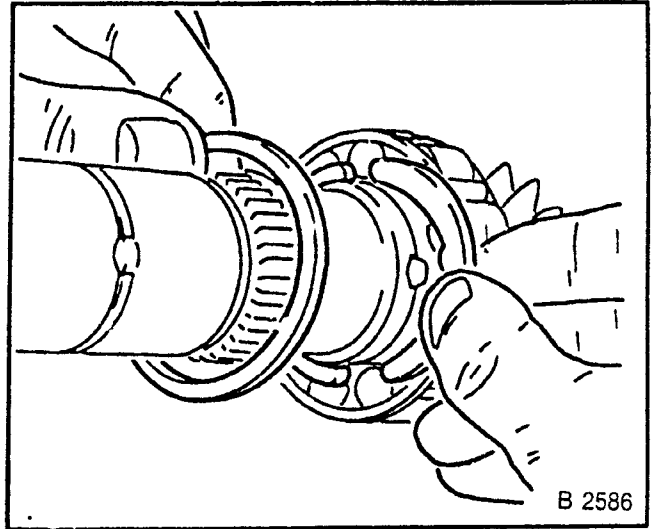


Fig. 167

**F 20, MANUAL TRANSMISSION:****INSTALL, CONNECT**

- 1 Push slotted roller bearing on to main shaft, which must engage audibly
2. Mount two-row slotted needle bearing and 4th gear on main shaft.

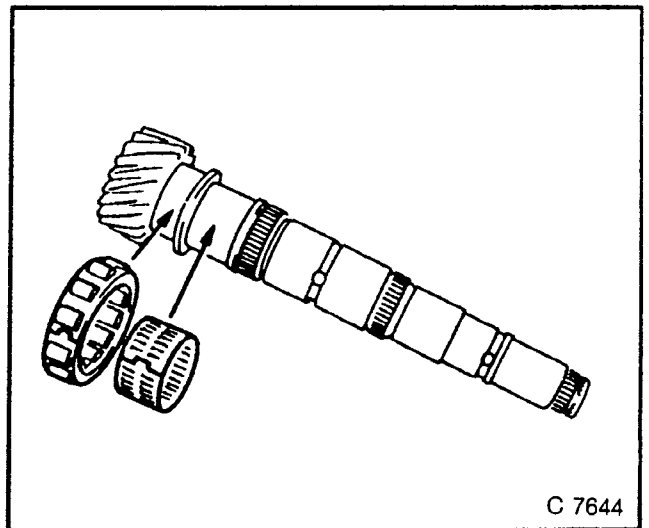


Fig. 168

**F 16 AND F 20 MANUAL TRANSMISSION:**

1. Lubricate needle bearing and bearing bore of gear with Transmission Fluid (B0400075).

**INSTALL, CONNECT**

1. Place synchronizer ring on cone of 4th gear
2. Heat 3rd/4th synchromesh body assembly to approximately 100°C/212°F and press on, KM-514 — (thermocolour pencil, if available, or use suitable temperature gauge).
3. Lubricate seating surfaces on main shaft with Transmission Fluid (B0400075).
4. Insert washer; new retaining ring.

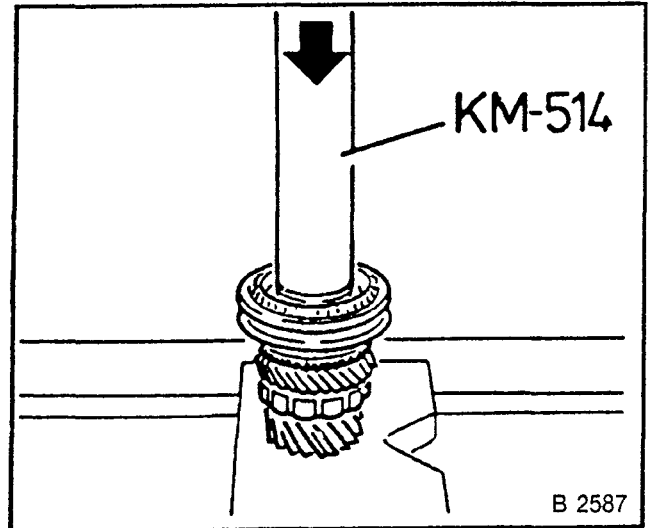


Fig. 169

5. Push slotted needle bearing on main shaft and 3rd gear (with synchronizer ring) on needle bearing.
6. Lubricate needle bearing, gear bore hole and seating surfaces of main shaft with Transmission Fluid (B0400075).
7. Join two thrust washer halves on main shaft with retaining ring.
8. Push needle bearing onto main shaft and 2nd gear onto needle bearing.
9. Lubricate needle bearing and bearing bore hole with Transmission Fluid (B0400075).
10. Place inner synchronizer ring, intermediate ring and outer synchronizer ring on cone of 2nd gear so that lugs fit in recesses of each outer synchronizer ring.

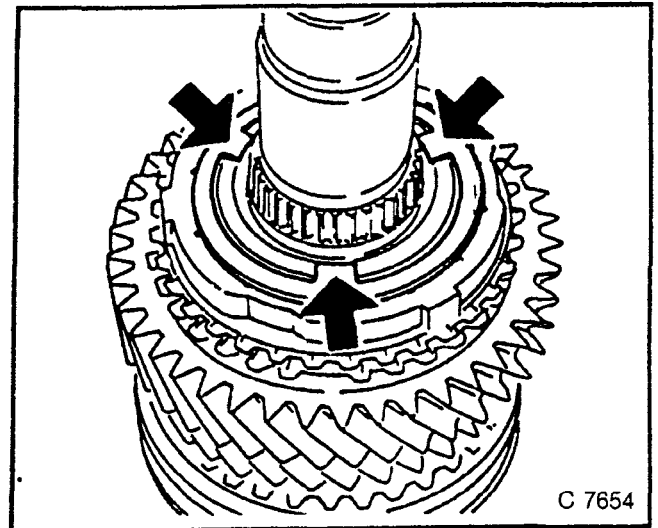


Fig. 170

**INSTALL, CONNECT**

1. Heat synchromesh body assembly to approximately 100°C/212°F (thermocolour pencils, if available, or use suitable temperature gauge).
2. Press 1st/2nd gear synchromesh body assembly onto main shaft so that groove in shift fork points to 1st gear, KM-514.
3. New retaining ring.

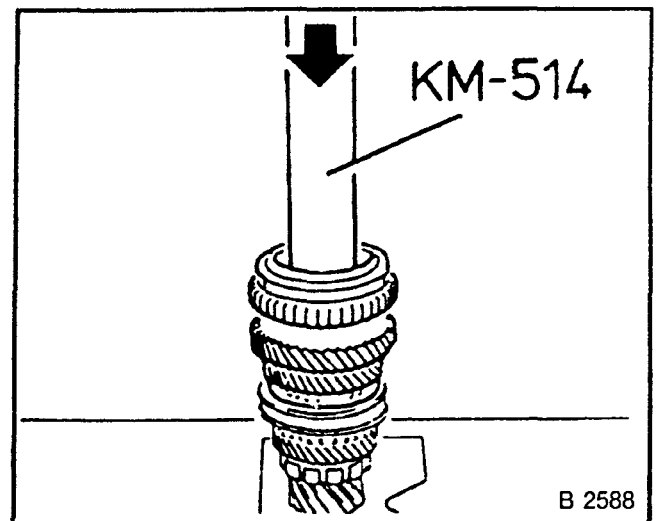


Fig. 171



- 4 Place outer synchronizer ring, intermediate ring and inner synchronizer ring on synchromesh body so that lugs fit in recesses of each outer synchronizer ring.
5. 1st gear needle bearing on main shaft.
- 6 Push 1st gear onto needle bearing.
7. Place axial needle bearing onto 1st gear.
8. Lubricate both needle bearings and bearing bore hole with Transmission Fluid (B0400075).

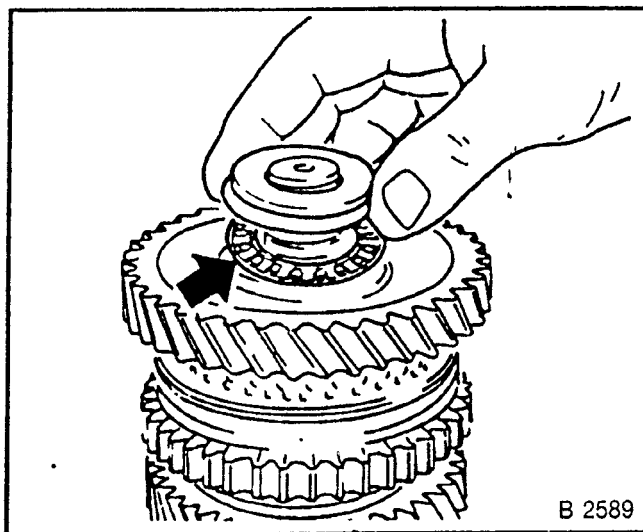


Fig 172

## INSTALL, CONNECT

1. Press on spacing washer first, then ball bearing, KM-334.
2. Attach new retaining ring with long sides (for main shaft to end shield).
3. Heat spacing washer to approximately 100°C/212°F (thermocolour pencils, if available, or use suitable temperature gauge).
4. Large diameter of washer points towards axial needle bearing.
5. Cage side of ball bearing points towards end shield side.
6. New retaining ring for ball bearing.
7. All gears should turn easily.

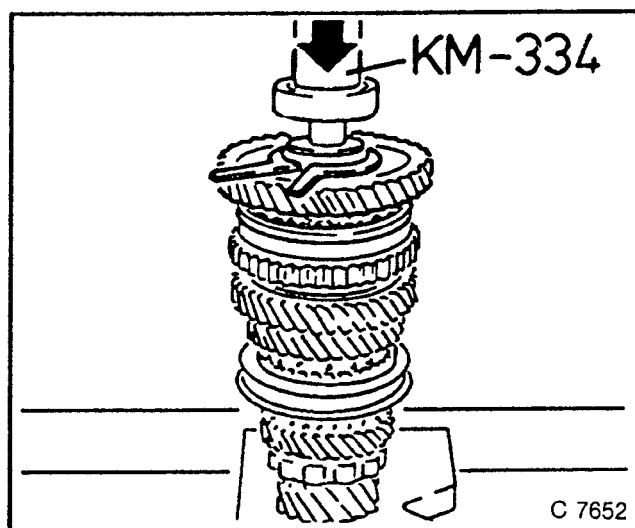


Fig 173

## Drive Shaft — Assemble

### F 10/F 13 MANUAL TRANSMISSION:

1. Press ball bearings onto gear cluster, KM-311/2.
2. Attach new retaining ring for gear cluster on end shield.
3. Secure ball bearing on gear cluster with new retaining ring.
4. Attach washer.
5. Press drive shaft into gear cluster.
6. With small longitudinal thread first; place KM-311/2 underneath.

**Do not** damage splines in gear cluster. Note different versions of drive shaft and gear cluster (gear ratios, see "Technical Data"; clutch splines, see P & A catalogue).

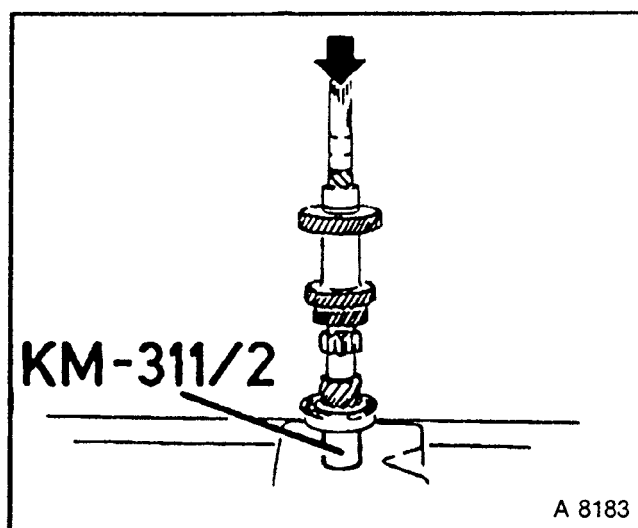


Fig 174

## Drive Shaft — Assemble

### F 16/F 20 MANUAL TRANSMISSION:

1. Press ball bearing onto gear cluster, KM-334.
2. Cage side of ball bearing points towards end shield side.
3. Attach new retaining ring for gear cluster to end shield.
4. New retaining ring for ball bearing.

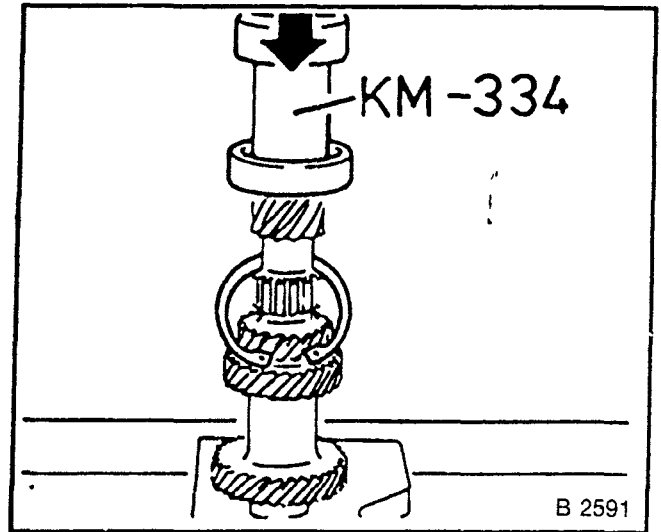


Fig 175

### INSTALL, CONNECT

1. Press drive shaft on, with thin part first, against ball bearing in gear cluster.

#### NOTE:

Do not damage splines in gear cluster.

Note relative dimensions:

Press drive shaft size 1 by hand into gear cluster:

Dimension A = 5 mm max.

If dimension A is smaller than 0 mm, use a drive shaft with size 2.

If dimension A is larger than 5 mm, replace gear cluster.

Colour coding:

Size 1 = green

Size 2 = no identification

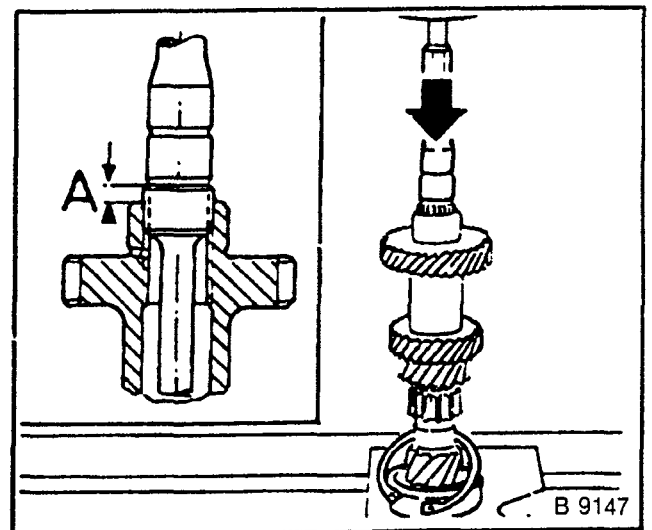


Fig 176

## End Shield — Assemble

### INSTALL, CONNECT

1. Axle for reverse idler gear with inserted retaining ball into end shield. Press in to stop.
2. Locking pin for gear stop in end shield bore (point 1 on assembly in Fig. 180)

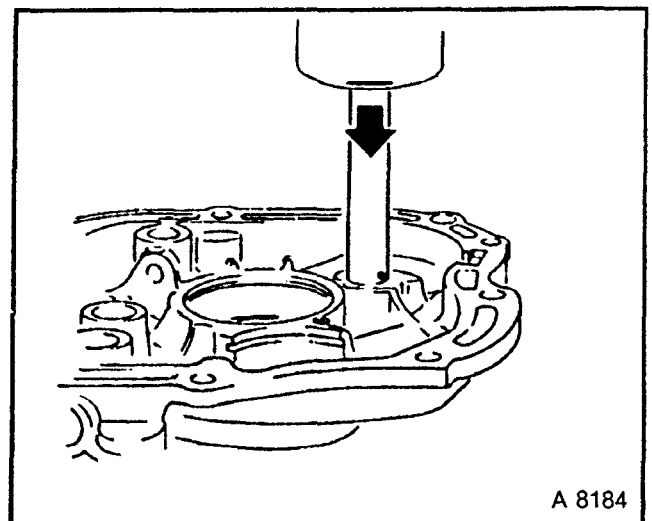


Fig. 177

3. Pin 1st/2nd gear shift fork and shift rod, KM-308/2.
4. Allow new pin to project approximately 2 mm.  
See assembly (Fig. 180) in this operation.

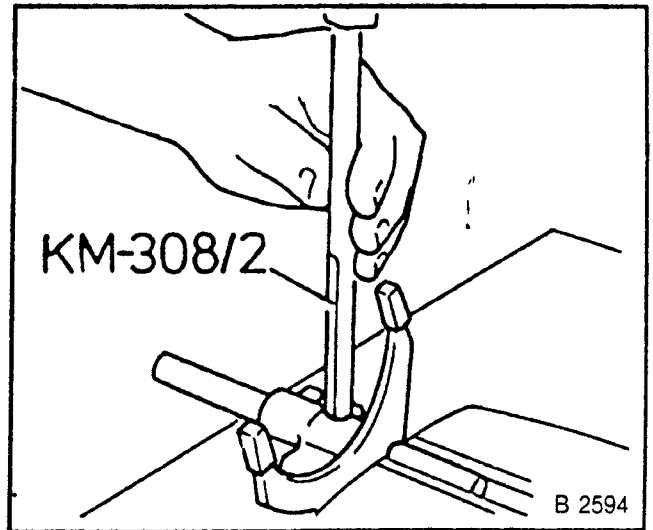


Fig 178

## INSTALL, CONNECT

1. Guide main shaft.
2. Drive shaft.
3. 1st and 2nd gear shift fork.
4. Shift rod.
5. Reverse idler gear into end shield.
6. End shield attached to KM-552.
7. Reverse idler gear shift fork nut points upwards (arrow).
8. Lubricate reverse idler gear bore hole with Transmission Fluid.
9. Place thrust washer on reverse idler gear shaft.
10. Secure main shaft and drive shaft, KM-444-3.
11. New retaining rings should lock properly in grooves.

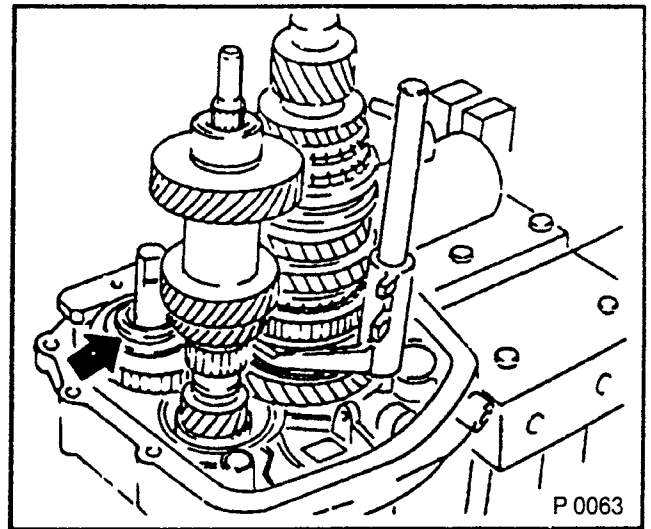


Fig 179

- 1: Gear catch locking pin
- 2: 5th gear shift driver
- 3: Reverse gear shift fork
- 4: Reverse gear shift rod
- 5: 3rd/4th gear shift rod
- 6: 3rd/4th gear shift fork
- 7: 1st/2nd gear shift fork and shift rod

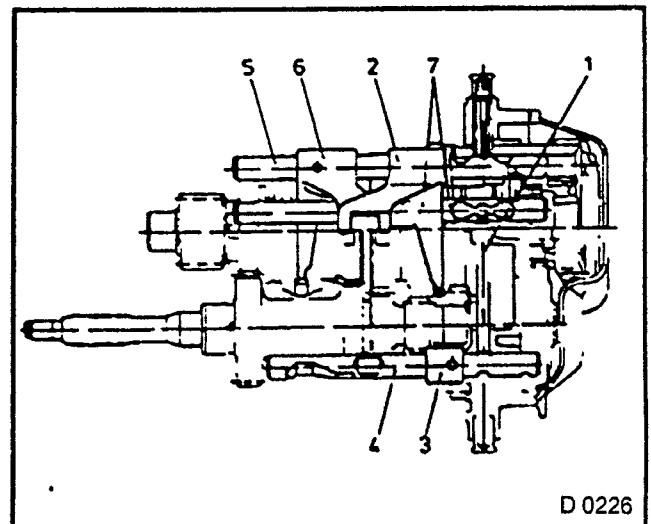


Fig. 180

## INSTALL, CONNECT

1. Insert and pin together reverse gear shift rod (Item 4, Fig. 180).
2. Shift fork (Item 3).
3. 5th gear shift driver (Item 2).
4. 3rd/4th gear shift rod (Item 5).
5. Shift fork (Item 6).
6. Locking pin for gear catch (Item 1) in end shield.
7. KM-308.
8. New tension pins.
9. Disengage rod guides; support shift rods with wood.

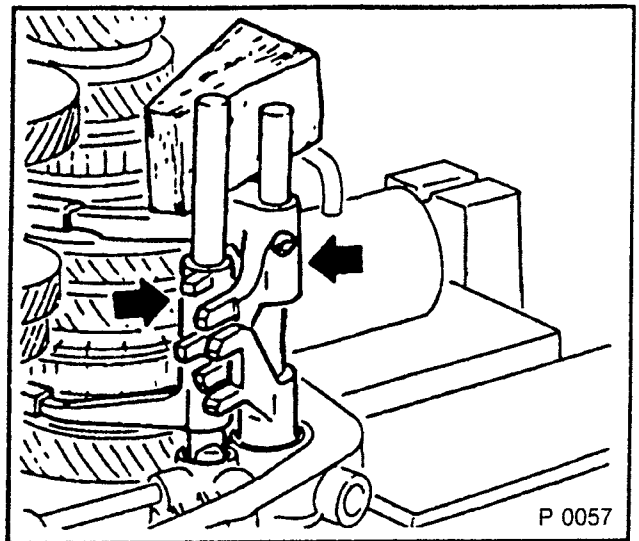


Fig 181

## TIGHTEN (TORQUE)

1. Bridge for locking pin on end shield, 7 Nm.
2. Insert new bolts with Locking Compound (Loctite 242).

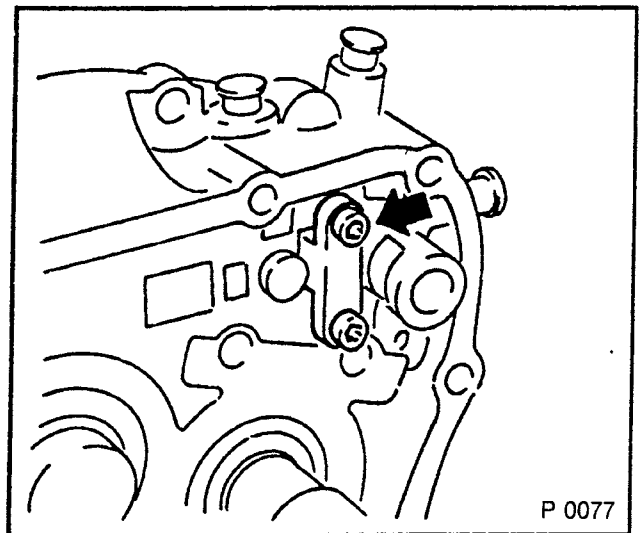


Fig 182

## TIGHTEN (TORQUE)

1. Bearing support with pawl on end shield, 7 Nm.
2. Slot in 3rd/4th gear shift rod must align with pawl.
3. Insert new bolts with Locking Compound (Loctite 242).

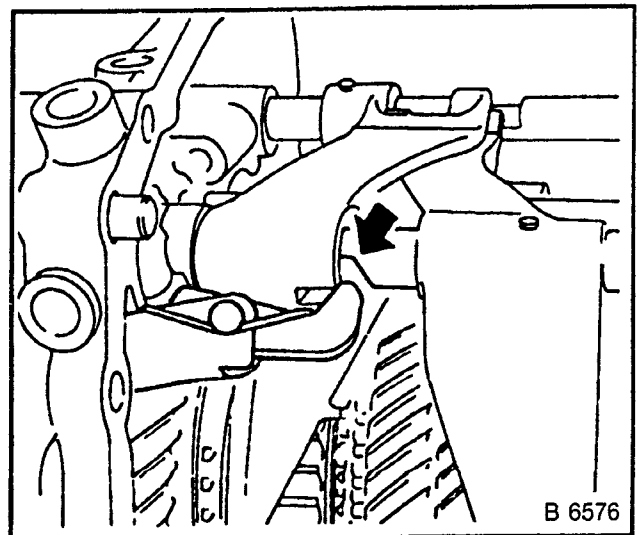


Fig. 183

**INSTALL, CONNECT**

1. Drive four detent pin plugs for ball stop oiltight into end shield.
2. One long plug (1).
3. Three short plugs (2).
4. Use plastic hammer or soft metal drift.

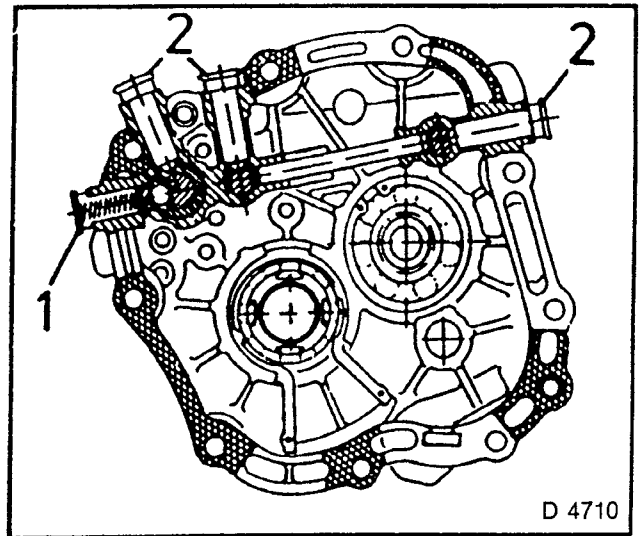


Fig 184

**INSTALL, CONNECT**

1. Place end shield assembly onto KM-554.
2. Press 5th gear (driving) onto gear cluster, KM-466-3.
3. Long gear hub points towards ball bearing
4. New retaining ring.
5. Push 5th gear (driven) and synchronizer ring onto main shaft.

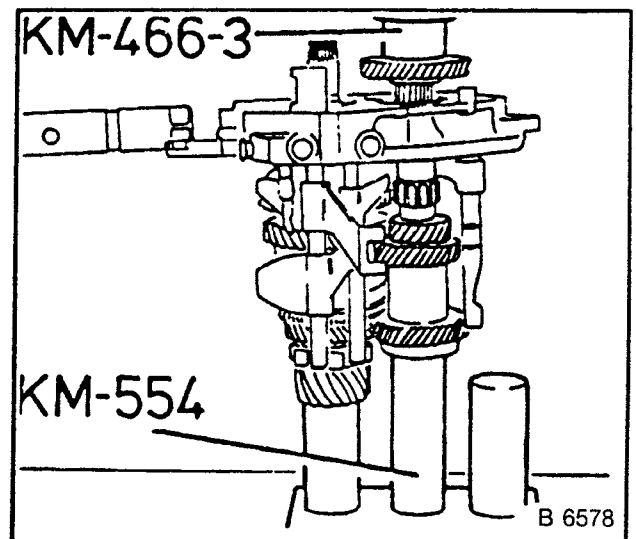


Fig. 185

6. Press 5th gear synchronesh body onto main shaft, KM-334.
7. Heat assembly to approximately 100°C/212°F (thermocolor pencils, if available, or use suitable temperature gauge).
8. Synchronizer spring points towards gear.
9. New retaining rings.

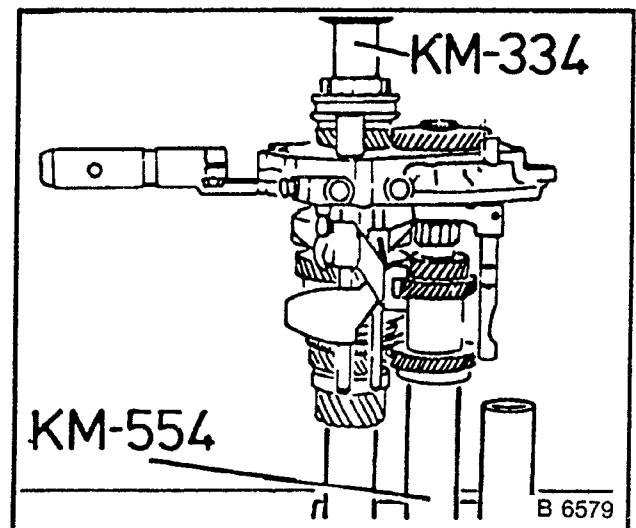


Fig 186

**INSPECT**

- 1 Thread for bearing support for free movement, recut M8 x 1.25 if required.

**TIGHTEN (TORQUE)**

1. Bearing support with rocker arm (arrows) to end shield, 22 Nm.
2. Insert new bolts with Locking Compound (Locktite 242).

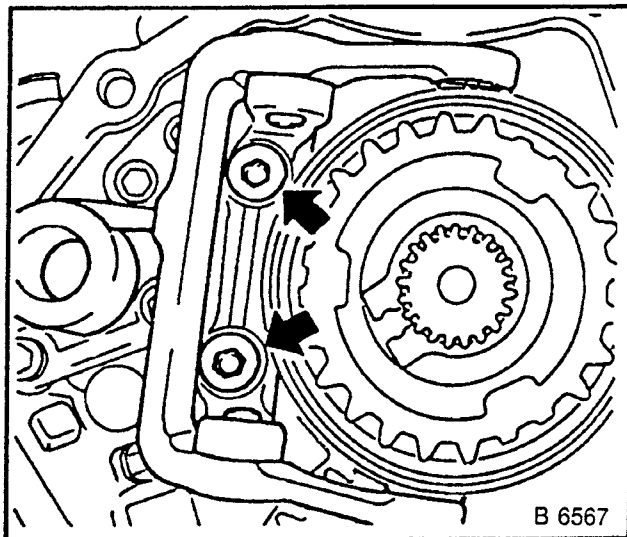


Fig 187

3. Stick new gasket onto transmission with bearing grease.
- 4 Place magnet in end shield.
5. End shield assembly (without transmission cover) carefully to transmission, 20 Nm.
6. End shield cover to end shield, M7 x 1.0 — 15 Nm. M8 x 1.25 — 20 Nm.
7. Speedometer helical gear (driven) with new rubber O-ring 4 Nm.
8. Lubricate splines, Anti-friction Bearing Grease (B0400852).
9. Reversing light switch to transmission, 20 Nm.
10. Shift cover to transmission, 15 Nm (measurement necessary).
11. Install transmission.

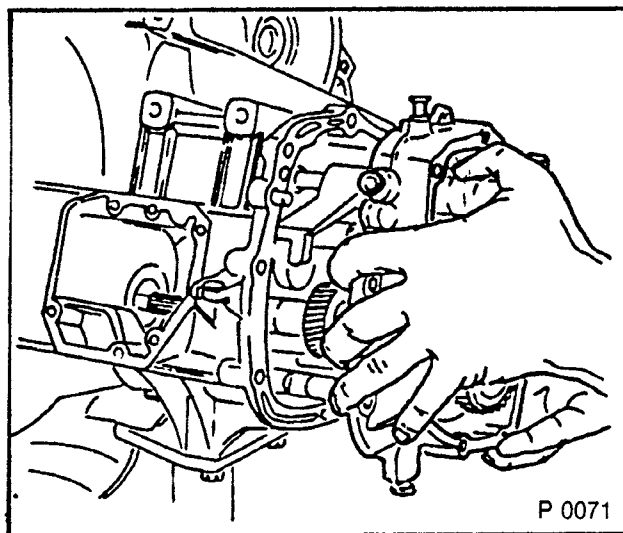


Fig. 188

## Synchronizer Rings — Replace

### TO BE CARRIED OUT WITH INSTALLED TRANSMISSION

The removal of the transmission is only necessary when replacing transmission housing or for additional operations in Section J.

**REMOVE, DISCONNECT**

- 1 Shift cover from transmission.
2. Reversing light switch from transmission.
- 3 End shield from transmission — see “Sealing Operations on Installed Transmission” Page 30.

Operations on main shaft and drive shaft:  
see “Manual Transmission, Overhaul”  
Page 62.

**Drive Gears (Driving and Driven) — Remove and Install****TRANSMISSION INSTALLED****DRIVE GEAR (DRIVEN), REMOVE AND INSTALL:****REMOVE, DISCONNECT**

1. Differential — see “Differential, Overhaul” Page 48.
2. Differential housing in vice,  
F 10, F 13 — KM-520  
F 16, F 20 — KM-524-A.
3. Knock off drive gear from differential housing with brass drift.

**TORQUE — ANGLE METHOD**

- 1 Drive gear to differential housing, 70 Nm plus additional turn of 30° to 45°.
2. Heat drive gear to 80°C/176°F in water bath (thermocolor pencils, if available, or use suitable temperature gauge).
3. Install differential into transmission — prescribed adjustment tapered roller bearing (differential housing).
4. Differential cover to transmission,  
Sheet metal version 30 Nm.  
Light alloy version 18 Nm.
5. Fill up with transmission fluid — see “Transmission Fluid Level, Check” Page 19.

## Drive Gear (Driving) — Remove and Install

### REMOVE, DISCONNECT

- 1 Both front wheels.
- 2 Shift cover from transmission — see “Sealing Operations on Installed Transmission” Page 30.
- 3 End shield from transmission — see “Sealing Operations on Installed Transmission” Page 30.
- 4 Main shaft and drive shaft from end shield — see “Manual Transmission, Overhaul” Page 62.
5. Drive gear  
**F 10, F 13** — Press off drive gear from main shaft, KM-307-B and suitable drift; remove retaining ring.  
**F 16, F 20** — Disassemble main shaft completely, main shaft and drive gear (driving) are one part.  
If necessary, replace needle sleeve and roller bushing in transmission housing. See “Manual Transmission, Overhaul” Page 62.

### INSTALL, CONNECT

1. **F 10, F 13** — Heat drive gear to approximately 100°C/212°F (check temperature with thermocolour pencils, if available, or use suitable temperature gauge).
2. Press drive gear onto main shaft.
3. Secure with retaining ring, KM-331-2.  
  
For **F 16, F 20**-Assemble main shaft.
  1. Main shaft and drive shaft in end shield. See “Manual Transmission, Overhaul” Page 62.
  2. End shield onto transmission — see “Transmission, Seal” Page 30.
  3. Shift cover onto transmission (measurement required).
  4. Fill up with Transmission Fluid (B0400075).
  5. Adjust transmission shift linkage.
  6. Tighten wheel bolts alternating crosswise, 110 Nm.



## Speedometer Helical Gear (Driving) — Remove and Install

### TRANSMISSION INSTALLED

#### REMOVE, DISCONNECT

1. Axle shafts from transmission — see “Axle Shaft Seal Rings, Replace” Page 30.
2. Differential — see “Differential, Overhaul” Page 48.
3. Knock off speedometer helical gear (driving) from differential housing.
4. Press on new speedometer helical gear until it catches; **F 10, F 13** — KM-458; **F 16, F20** — KM-525.
5. Heat helical gear and tool to 80°C/176°F (water bath, suitable temperature gauge)

#### INSTALL, CONNECT

1. Differential onto transmission — prescribed adjustment tapered roller bearing (differential housing).

#### TIGHTEN (TORQUE)

1. Differential cover to transmission  
Sheet metal version 30 Nm.  
Light alloy version 18 Nm.
2. Fill up with Transmission Fluid (B0400075) — see “Transmission Fluid Level, Check and Correct” Page 19.

## Speedometer Helical Gear (Driven) — Remove and Install

Corresponds to operation “Rubber O-ring for Speedometer Helical Gear (Driven), Replace” Page K-32.

## CLUTCH

### Clutch Disc and Pressure Plate — Remove and Install

As of May '92, the previous flat flywheel is being gradually replaced by a pot flywheel. Before clutch repairs, check whether a pot flywheel is installed in the affected vehicle by removing the closure cover.

1. Remove the manual transmission on vehicles with pot flywheels.  
Vehicles with flat flywheel: manual transmission installed.
2. Retaining clamp (arrow) from cable.
3. Press back clutch release lever with installing iron.
4. Cable from clutch release lever.

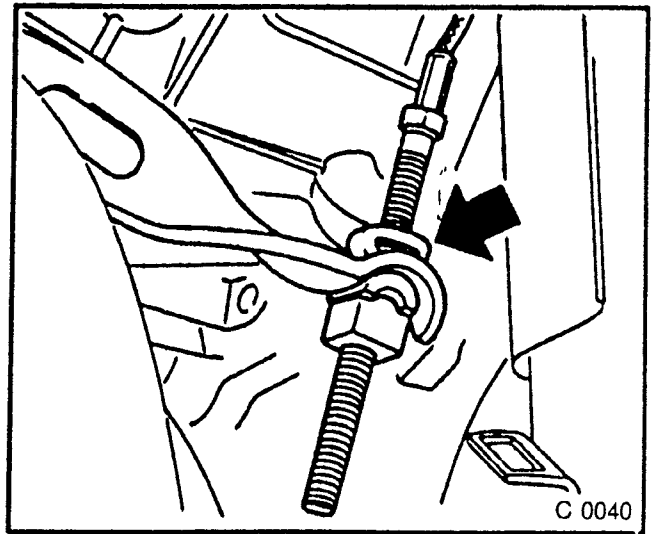


Fig. 189

### REMOVE, DISCONNECT

1. Left front wheel.
2. End shield cover, fluid escapes.
3. Clutch closure cover.
4. Retaining ring from drive shaft (arrow).
5. Fillister head bolt from drive shaft.

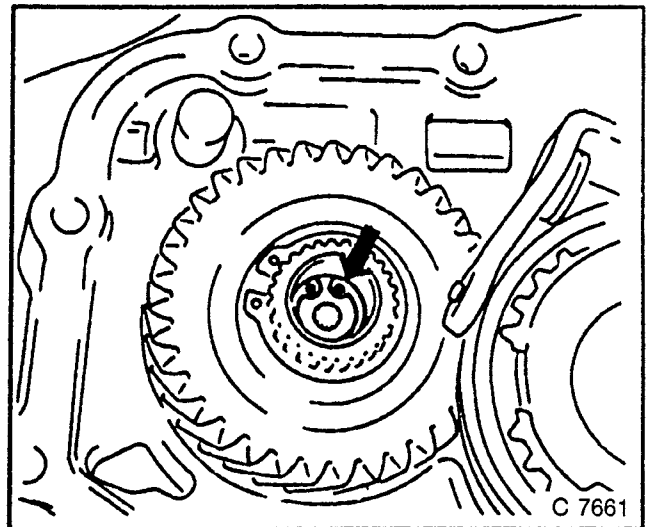


Fig. 190

### REMOVE, DISCONNECT

1. Remove transmission drive shaft with KM-556-1-A and KM-556-4 up to stop from gear block and clutch disc.

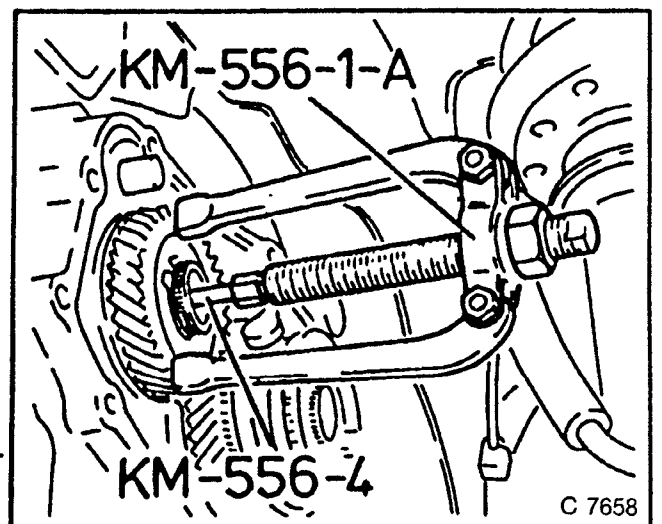


Fig. 191

2. Press back release lever with installing iron to tension diaphragm spring of clutch pressure plate.
3. Attach three Clamps KM-526-A (arrow) distributed around circumference.

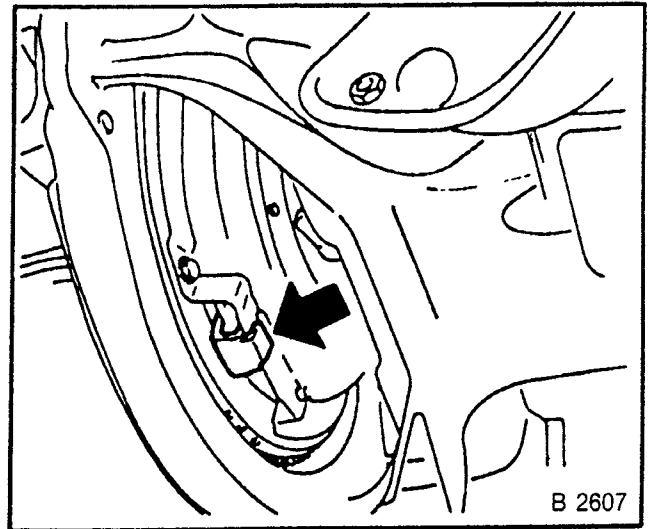


Fig. 192

**INSTALLED OR REMOVED TRANSMISSION:****REMOVE, DISCONNECT**

1. Clutch pressure plate with clutch disc from flywheel.
2. Clutch pressure bearing from clutch fork.
3. Fastening bolt (arrow) of clutch fork.

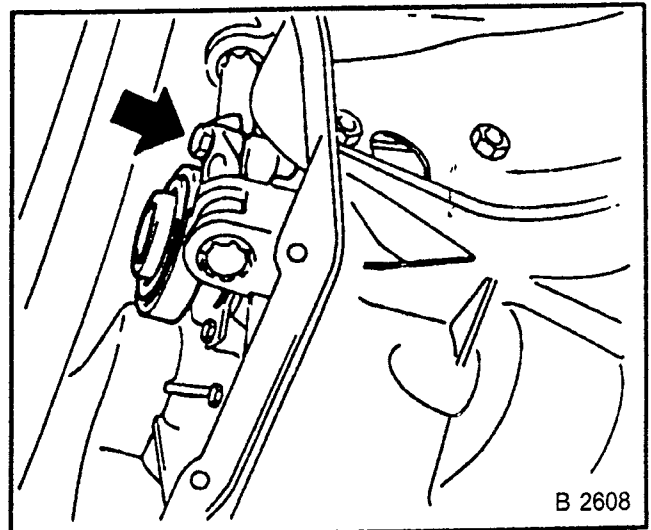


Fig. 193

**REMOVE, DISCONNECT**

1. Clutch release lever.
2. Clutch fork.
3. Pressure bearing guide (arrow).
4. Seal ring from pressure bearing guide.

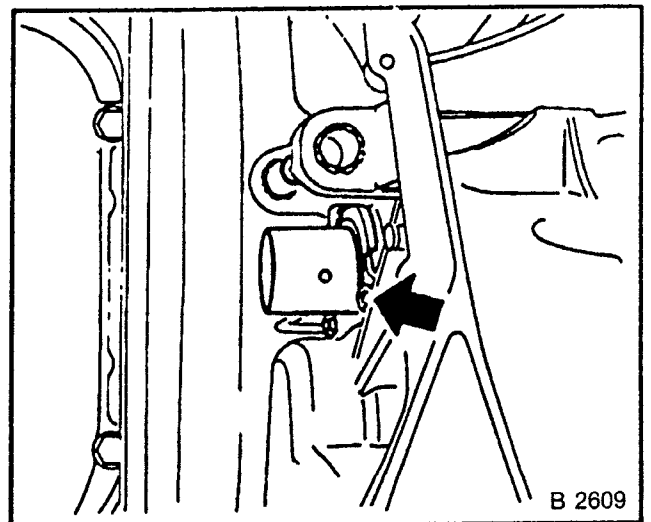


Fig. 194

**INSTALL, CONNECT**

1. New seal ring into pressure bearing guide.
2. Fill seal ring between sealing lips with
3. Multipurpose Grease (B0400852).
4. Press in seal ring:  
**F 10, F 13 — KM-445.**  
**F 28/6, F 16, F 20 — KM-518.**
5. Rubber O-ring into housing groove, free of grease and oil.

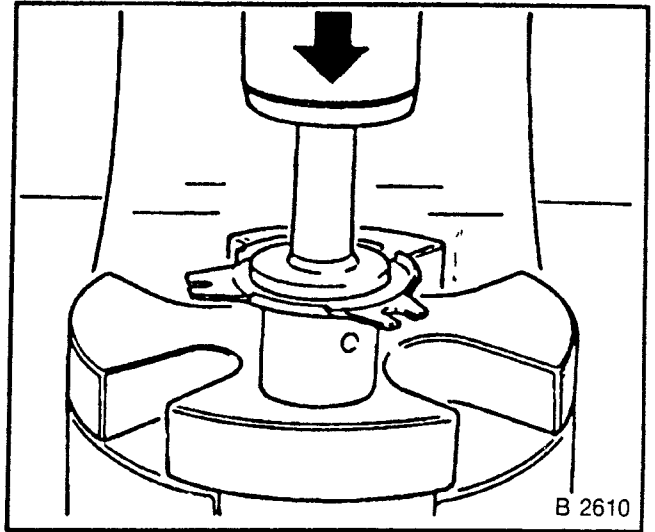


Fig 195

**TIGHTEN (TORQUE)**

1. Pressure bearing guide to transmission, 5 Nm.
2. Lubricate gliding surface for clutch pressure bearing, Grease (B0400852).
3. Clutch pressure bearing, clutch fork to clutch release lever, 35 Nm.

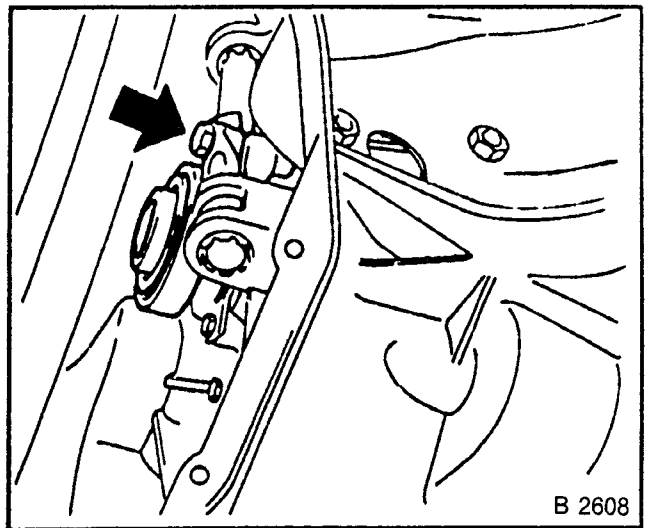


Fig. 196

**TRANSMISSION INSTALLED:**

If clutch pressure plate is being replaced:

1. Press diaphragm spring of clutch pressure plate under clamp.
2. Install three Clamps KM-526-A distributed on circumference of new clutch pressure plate.

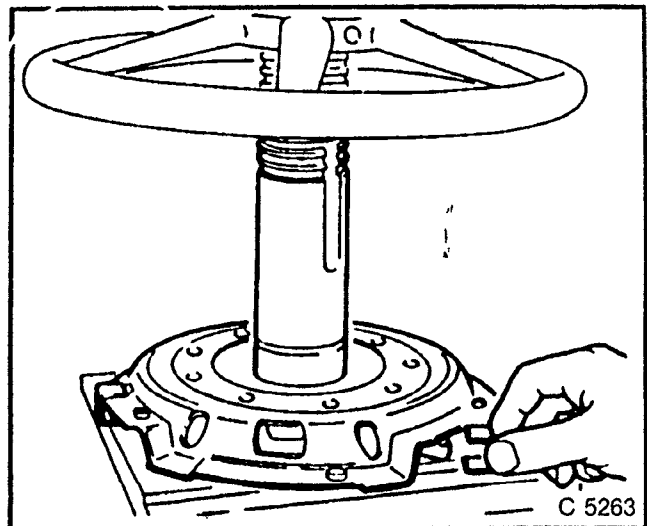


Fig. 197

**INSTALL, CONNECT**

1. Clutch pressure plate with clutch disc loosely on flywheel.
2. Lubricate splines of clutch disc, Grease (B0400852).
3. If there is no inscription "Getriebeseite" (transmission side), install long part of clutch disc hub pointing to transmission.

**NOTE:**  
**MARKS ON CLUTCH PRESSURE PLATE AND FLYWHEEL (ARROW) MUST MATCH.**

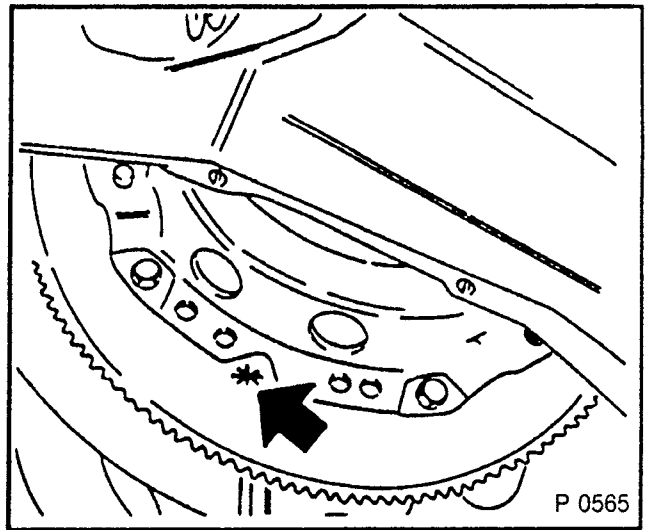


Fig 198

**INSTALL, CONNECT**

1. Raise clutch plate and centre with transmission drive shaft.
2. Insert drive shaft into clutch plate and gear cluster splines carefully by hand.

**TIGHTEN (TORQUE)**

- 1 Clutch assembly to flywheel, 15 Nm.

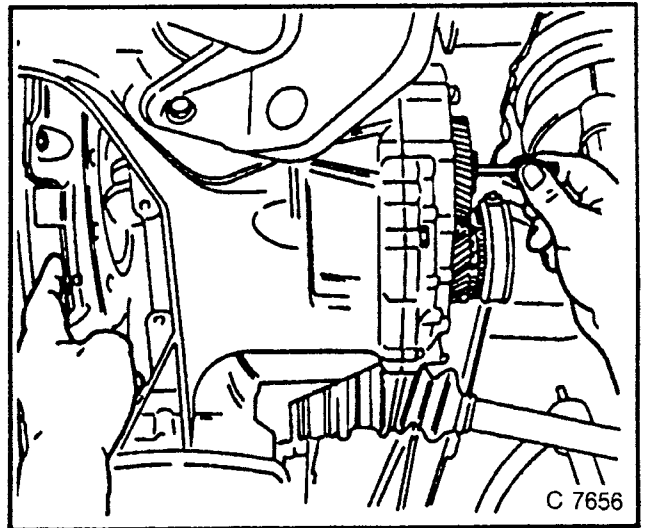


Fig. 199

2. Fillister head bolt in drive shaft — 15 Nm.

**INSTALL, CONNECT**

1. Press in drive shaft until stop, KM-564.
2. Fillister head screw in drive shaft.

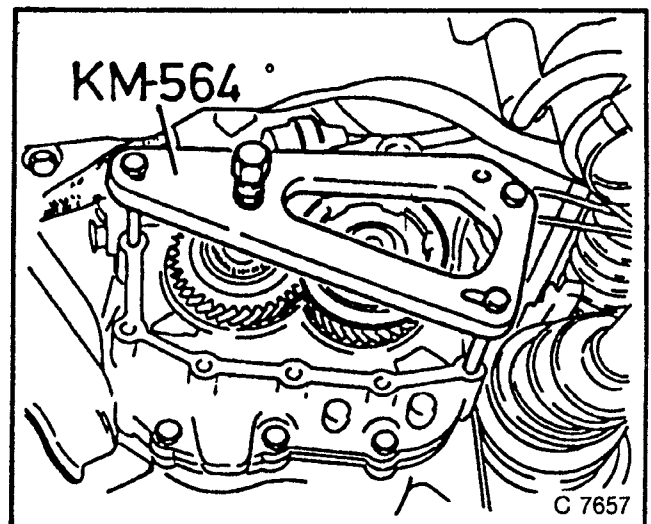


Fig. 200

**REMOVE, DISCONNECT**

1. KM-564.
2. KM-526-A (arrow) with clutch release lever actuated.

**TIGHTEN (TORQUE)**

1. Clutch closure cover to transmission:  
Sheet metal version; 12 Nm.  
Light alloy version; 6 Nm.
2. Transmission cover to transmission and end shield,  
M 7 x 1.0 — 15 Nm.  
M 8 x 1.25 — 20 Nm.

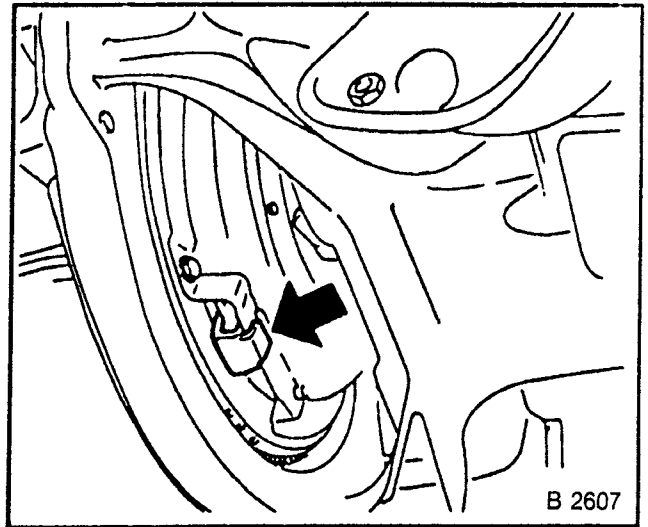


Fig. 201

**TRANSMISSION REMOVED: CENTRE CLUTCH DISC**

|                                   |           |           |        |
|-----------------------------------|-----------|-----------|--------|
| Manual transmission               | F 10/F 13 | F 16/F 20 | F28/6  |
| 2,0 LET Engine                    | —         | —         | KM-736 |
| Crankshaft with needle bearing    | —         | KM-534    | —      |
| Crankshaft without needle bearing | KM-734    | KM-735    | —      |

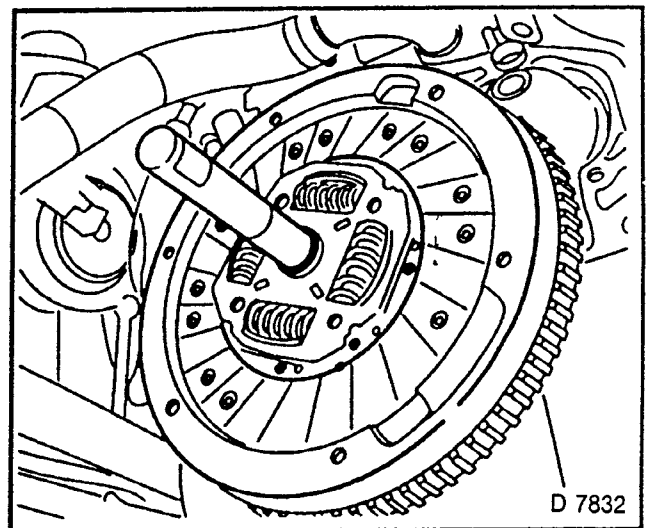


Fig. 202

**INSTALL, CONNECT**

1. Clutch pressure plate to flywheel, 15 Nm.

**NOTE:**  
MARKS ON CLUTCH PRESSURE PLATE AND FLYWHEEL MUST MATCH.

**INSTALL, CONNECT**

1. Manual transmission.

**ALL TRANSMISSIONS:****INSPECT**

1. Transmission fluid level.

**INSTALL, CONNECT**

1. Clutch cable to release lever.
- 2 Retaining clamp (arrow).

**ADJUST**

1. Clutch pedal.  
See "Clutch Cable, Replace" Page 96.

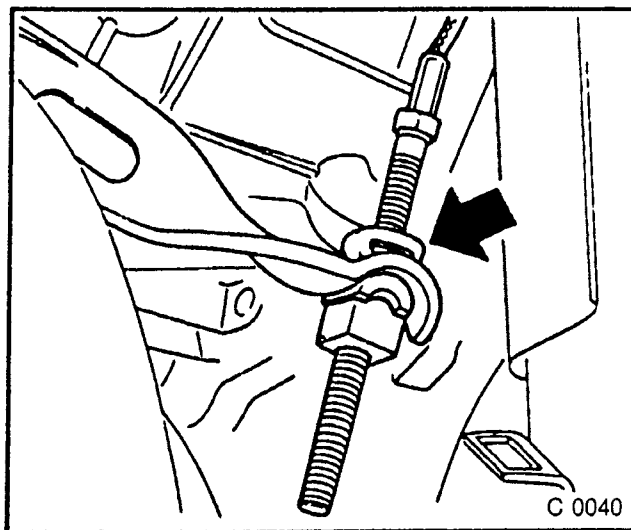


Fig 203

## Clutch Pressure Bearing and Release Lever — Remove and Install

This operation corresponds to "Clutch Disc and Pressure Plate, Remove and Install" Page 90.

The procedure differs for vehicles with pot flywheel and for vehicles with flat flywheel.

## Bearing Bushings for Clutch Release Lever — Remove and Install

ALL TRANSMISSIONS EXCEPT F 28/6

**REMOVE, DISCONNECT**

1. Clutch pressure bearing and release lever. See operation "Clutch Disc and Pressure Plate, Remove and Install" Page 90.
2. Bearing bushings for clutch release lever, KM-304.

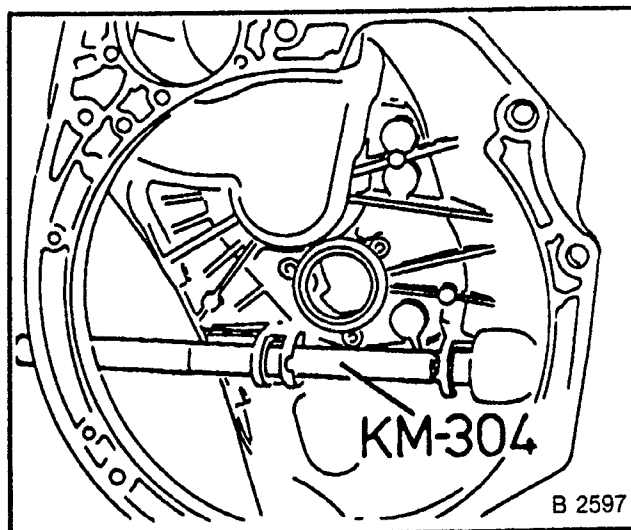


Fig. 204

**INSTALL, CONNECT**

1. New bearing bushings (arrows), KM-J-7004, with washer.
2. Bushing cam should lie in housing recess.
3. Lubricate bushing inner surface, Multipurpose Grease (B0400852).

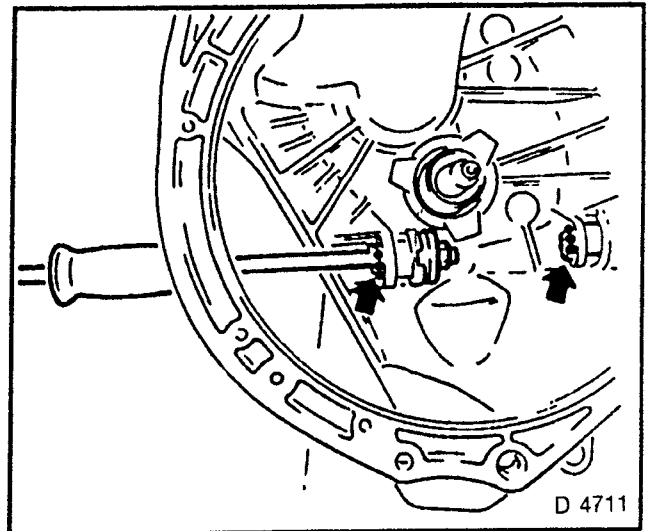


Fig. 205

**F 28/6 TRANSMISSION:****REMOVE, DISCONNECT**

1. Clutch pressure bearing and release lever See "Clutch Disc and/or Pressure Plate, Remove and Install" Page 90.
2. Press locking lugs together.
3. Press out bearing bushings.

**INSTALL, CONNECT**

1. Press in new bearing bushings until locking lugs engage.
2. Lubricate sliding surfaces of bushings, Grease (B0400852).

**Clutch Cable — Replace****MEASURE**

1. Thread length.

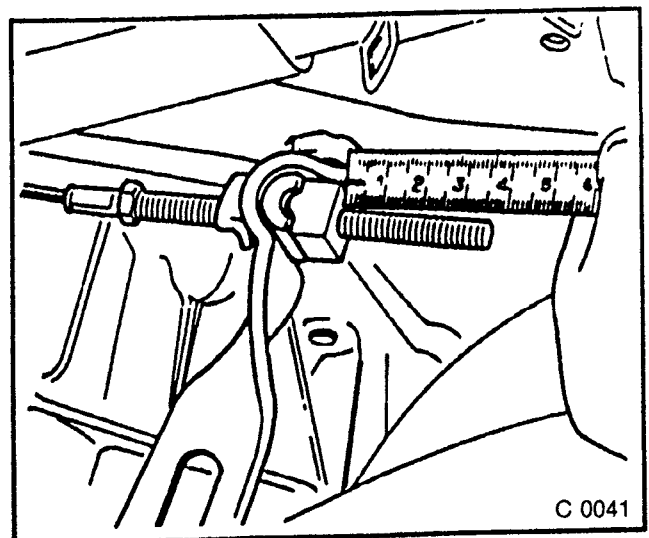


Fig. 206



**REMOVE, DISCONNECT**

1. Retaining clamp (arrow) from cable.
2. Press back release lever with installing iron.
3. Cable from release lever.
4. Cable from bracket for damper

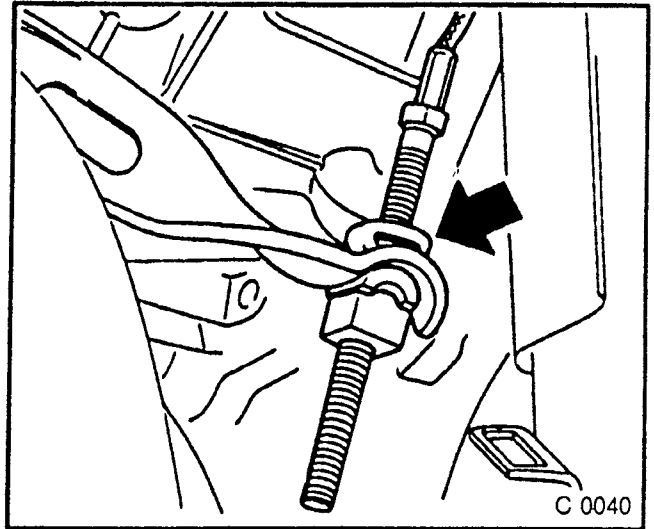


Fig. 207

**REMOVE, DISCONNECT**

1. Return spring and clutch cable from clutch pedal.

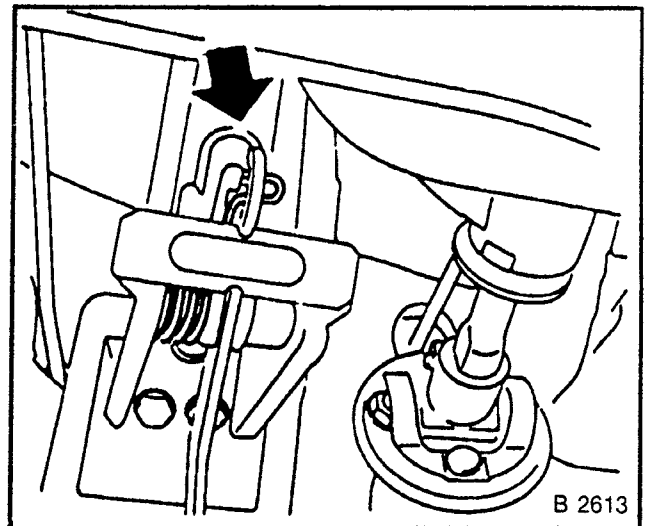


Fig. 208

2. Clutch cable.
3. Remove engine compartment side cable from bulkhead.

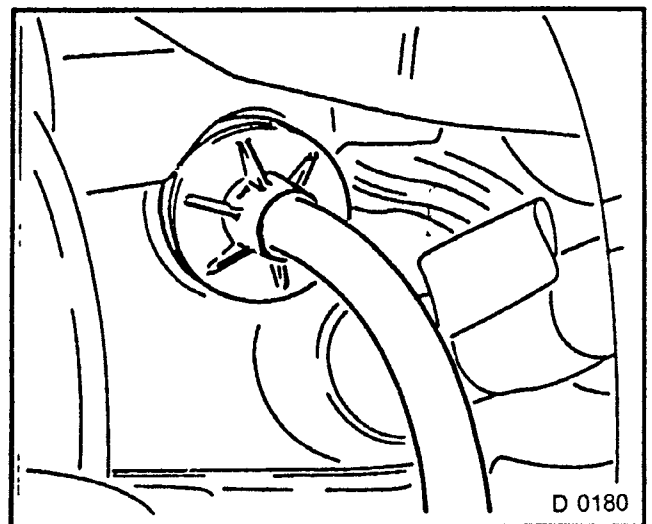


Fig. 209

## INSTALL, CONNECT

1. Clutch cable onto bulkhead.
2. Clutch cable and return spring to clutch pedal.
3. Cable in bracket for damper.
4. Clutch cable in release lever.
5. Adjust clutch actuating nut to measured value.

## ADJUST

### 1. CLUTCH PEDAL

Dimension A distance from middle of clutch pedal to lower edge of steering wheel circumference.  
Pedal not depressed.

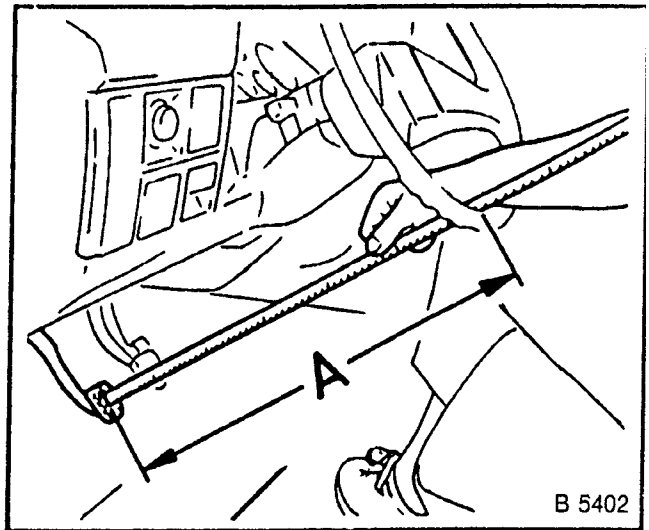


Fig. 210

### CLUTCH CABLE

Dimension B: Measure from lower edge of steering wheel circumference but with pedal depressed.

The difference between two values (B minus A) must be 134 to 141 mm.

2. Correct pedal displacement at cable threaded rod if necessary.
3. Secure cable with retaining clamp.

### NOTE:

Clutch pedal is higher than brake pedal. Placing pedals on the same level is not correct. There should be no play in clutch pedal. Clutch pedal moves upwards with progressive wear of clutch linings.

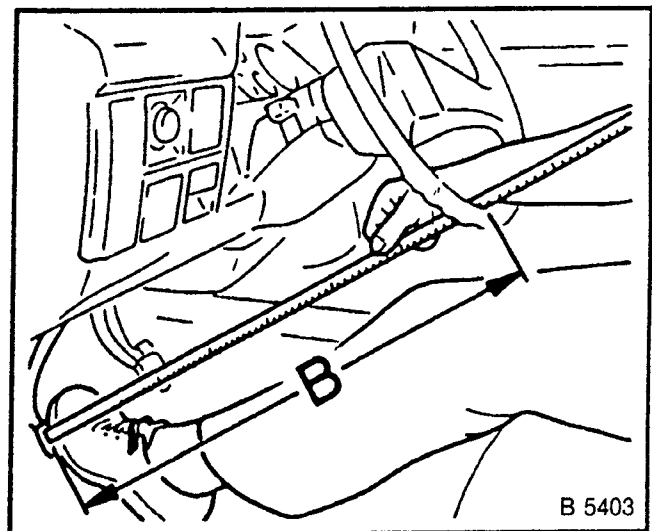


Fig. 211

## Clutch Pedal — Remove and Install

### REMOVE, DISCONNECT

1. Clutch cable from release lever.
2. Return spring from pedal support.
3. Retaining wire, hex nut and washers from pedal axle.
4. Pedal axle.
5. Pedal.
6. Return spring and clutch cable from clutch pedal.

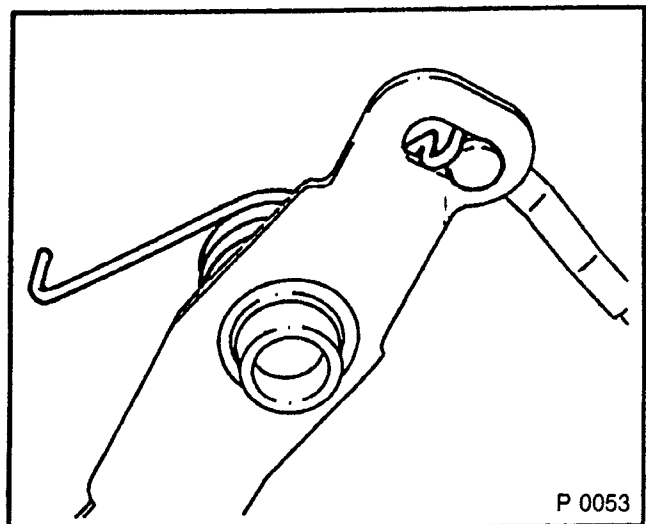


Fig. 212

**INSTALL, CONNECT**

1. Clutch pedal.
2. Lubricate pedal axle, Multipurpose Grease (B0400852).
3. Clutch pedal assembly replaced with pedal bushing.
4. Clutch cable and return spring onto pedal support.
5. Clutch cable onto release lever.
6. Secure clutch cable with retaining clamp.

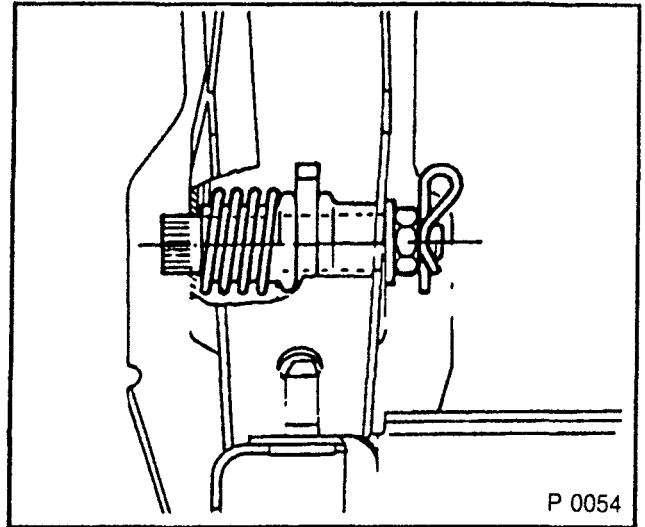


Fig 213

**INSPECT**

1. Clutch pedal adjustment.  
See "Clutch Cable, Replace" Page 96.

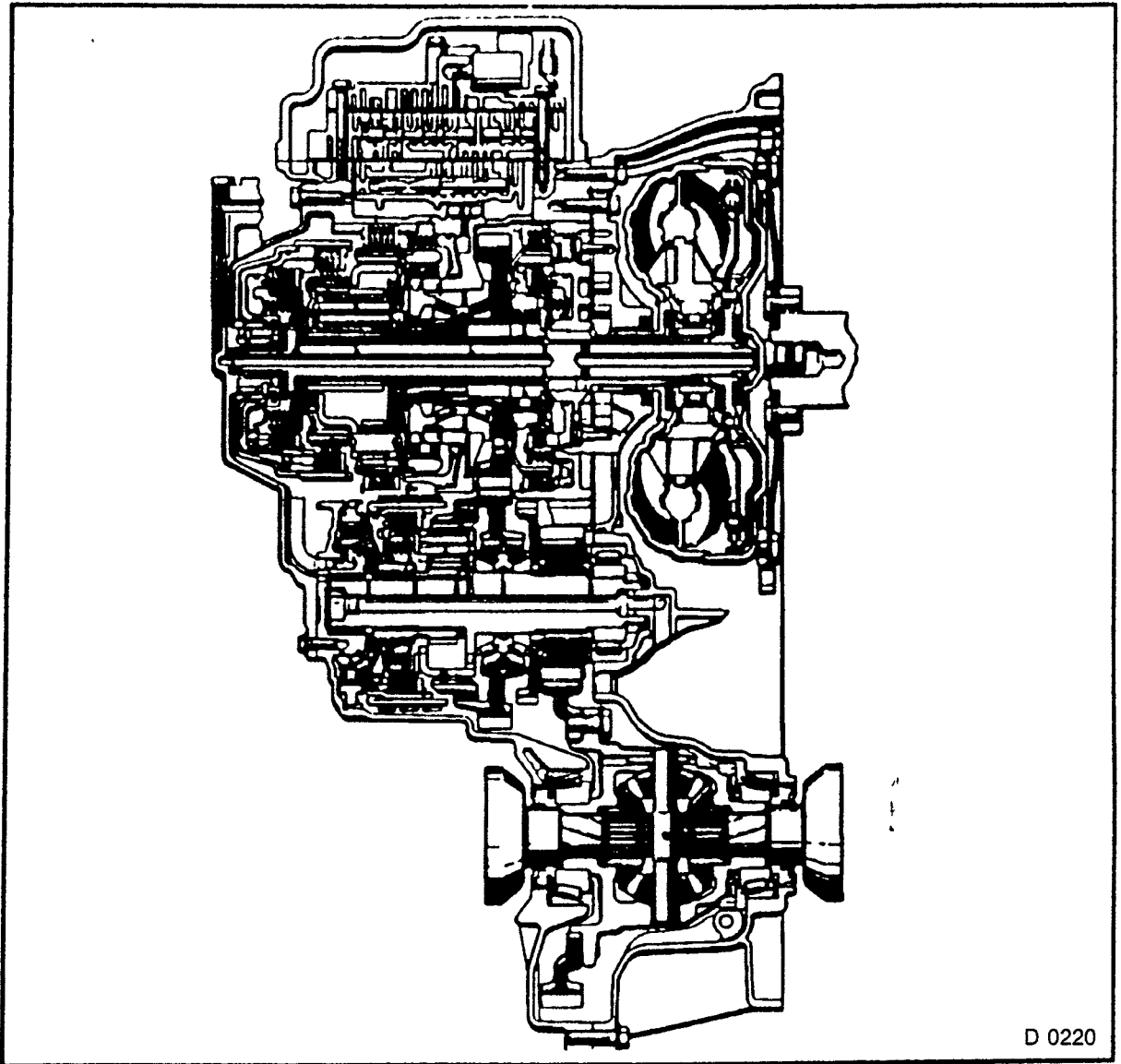
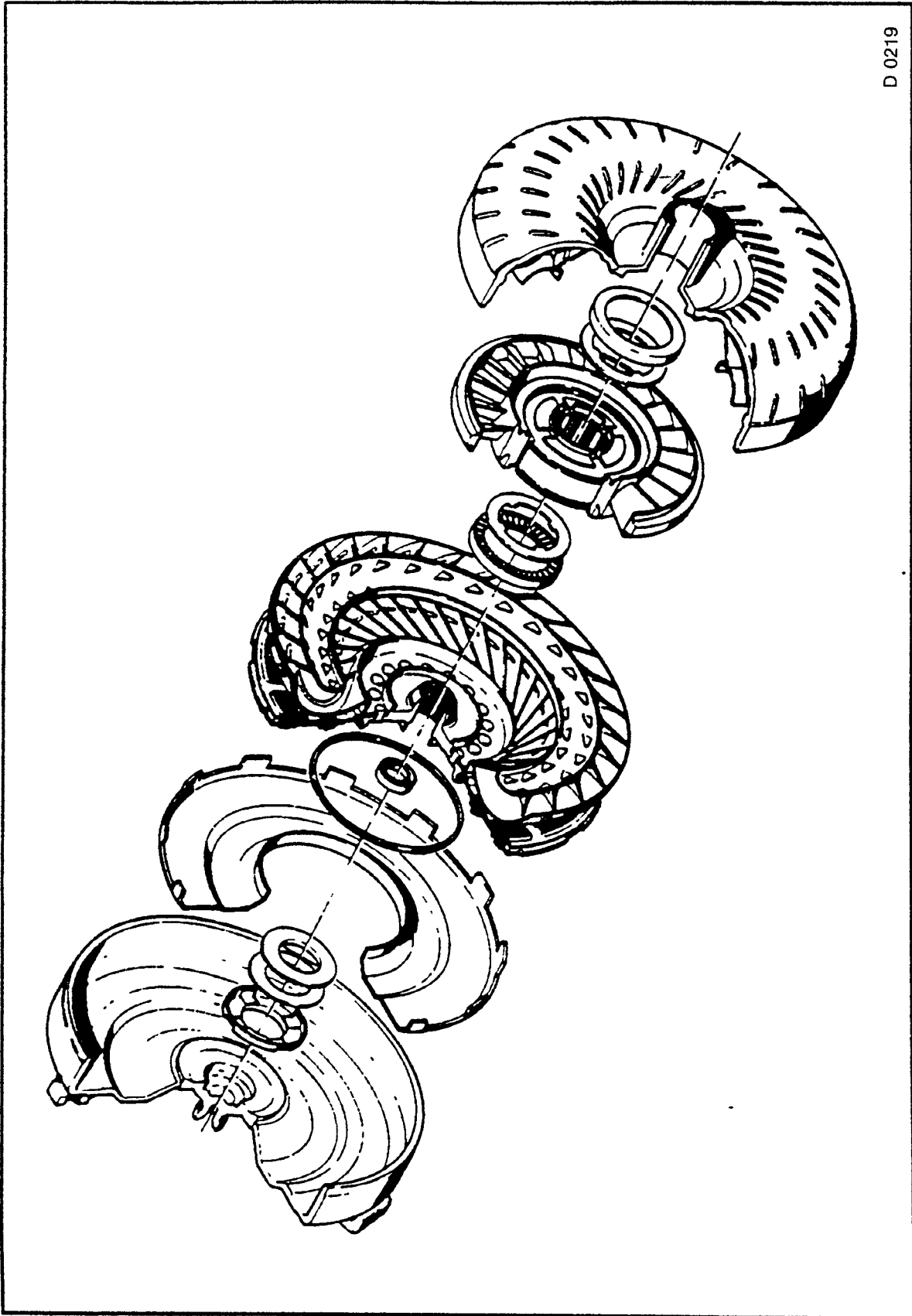


Fig. 214 — Automatic Transmission AF 20.

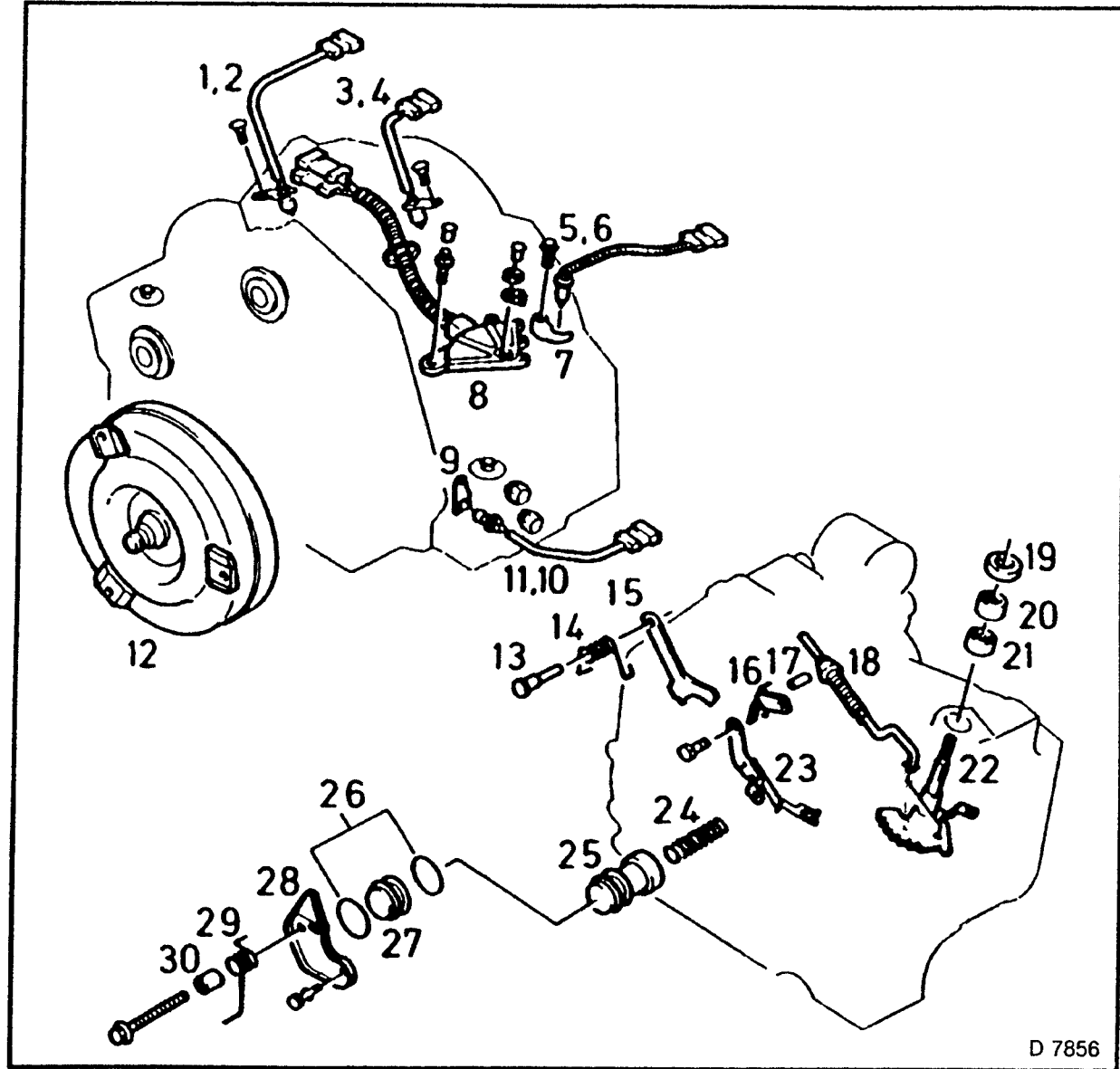


D 0219

Fig 215 — Converter and Bridge Clutch

- 1 = Sensor, transmission output speed
- 2 = Seal ring
- 3 = Sensor, transmission input speed
- 4 = Seal ring
- 5 = Solenoid valves wiring harness
- 6 = Seal ring
- 7 = Retaining plate
- 8 = Selector lever position switch
- 9 = Cover plate for fluid temperature sensor
- 10 = Seal ring
- 11 = Fluid temperature sensor
- 12 = Converter
- 13 = Axle for parking pawl
- 14 = Torsion spring no. 1
- 15 = Pawl for parking pawl
- 16 = Cam plate
- 17 = Pin for parking pawl
- 18 = Actuating rod for parking pawl
- 19 = Seal ring
- 20\*) = Outer needle bearing
- 21\*) = Inner needle bearing
- 22 = Ratchet
- 23 = Detent spring
- 24 = Compression spring
- 25 = Accumulator piston
- 26 = Seal rings
- 27 = Accumulator cover
- 28 = Accumulator bracket
- 29 = Torsion spring no. 2
- 30 = Sleeve for spring guide

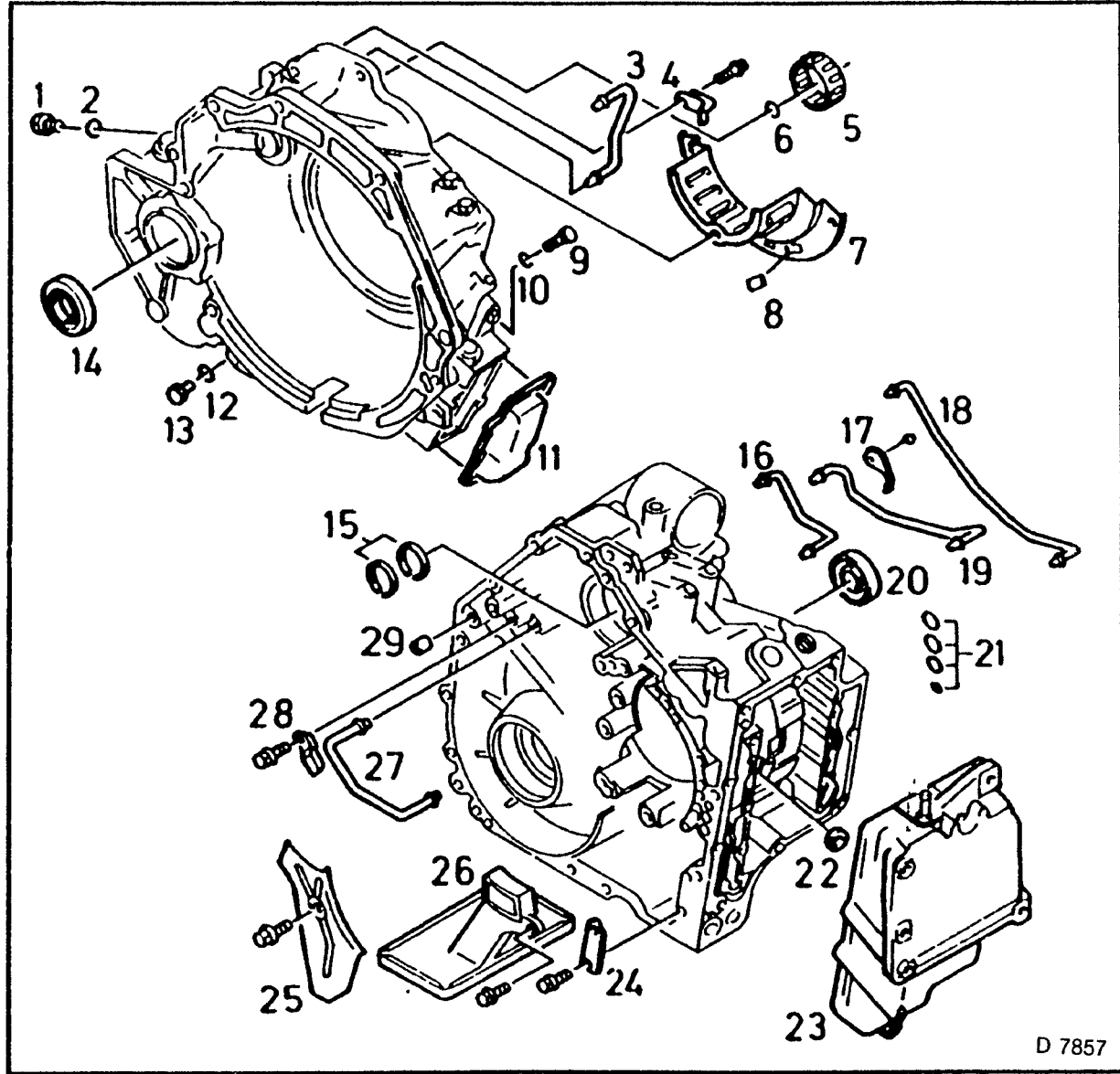
\*) One part on newer transmissions



D 7856

Fig 216 — AF 20 — attaching parts

- 1 = Plug — M8
- 2 = Seal ring
- 3 = Lubrication oil line
- 4 = Pipe clamp
- 5 = Roller bearing
- 6 = Seal ring
- 7 = Oil baffle plate, auxiliary housing
- 8 = Magnet (x 3)
- 9 = Plug — M8
- 10 = Seal ring
- 11 = Auxiliary housing cover
- 12 = Seal ring
- 13 = Drain bolt
- 14 = Axle shaft seal ring
- 15 = Hooked seal ring
- 16 = Main pressure pipe no. 1
- 17 = Pipe clamp
- 18 = Actuation pipe
- 19 = Lubrication pipe
- 20 = Axle shafts seal ring
- 21 = Gaskets for regulator
- 22 = Gaskets for actuation (x 2)
- 23 = Side cover
- 24 = Main housing plate
- 25 = Oil baffle plate, main housing
- 26 = Oil screen
- 27 = Main pressure pipe no. 2
- 28 = Pipe clamp
- 29 = Seal ring



D 7857

Fig 217 — AF 20 — housing parts

## AUTOMATIC TRANSMISSION AF 20

### Important Instructions for Operations on Automatic Transmissions

Before disassembling transmission, carry out fluid pressure check according to Checking Procedures. (Opel Electronic 4-Speed Automatic Transmission AF 14/20) in installed condition. The diagnosis will allow precise repairs to be made.

#### NOTE:

##### WHEN DISASSEMBLING:

During all operations on automatic transmissions, ensure that attaching parts and tools are as clean as possible. Malfunctions in transmissions are frequently caused by dirt and foreign objects.

Disconnect ground cable of battery before working on transmission.

Clean removed parts after disassembling, check for wear and damage. If defective seal rings are found when disassembling, inspect grooves and seating surfaces for foreign objects, burr formation or damage.

If metal chippings or clutch lining remnants are found when draining fluid, disassemble transmission completely and clean. If foreign objects are found when flushing converter, replace converter.

If a defect is found where floating particles could get into the fluid (bearing or gear is run in, clutch is burned), the valve body must be disassembled for flushing.

Proceed with the utmost caution, since inner parts of valve body are not available as replacement parts. **Do not** damage piston seal rings and springs. **Do not** lose retaining wedges.

The electrohydraulic pressure regulator is not available as a single part and if defective must be replaced together with the valve body (completely).

When disassembling valve body, set aside pistons, springs and valves as installed to avoid confusion. Thoroughly flush the valve body — especially the bore holes and ducts — and then blow dry. If in doing so chippings, scoring or other damage to functioning surfaces are visible, replace the valve body.

When placing attaching parts in vice, always use soft protective jaws.

If incorrect values are found when spin torques are measured, disassemble the relevant attaching part and overhaul bearings.

The retaining pin of Transmission Holder KM-694 is designed to be turnable and can be stopped after every 1/4 turn so that a favourable installing position can be attained.

Exception: When loosening housing bolts and separating housing parts, always keep transmission fixed horizontally (auxiliary housing points upwards), since assemblies are free and can fall out.

#### IMPORTANT!

##### WHEN ASSEMBLING:

Always renew gaskets and securing elements, **DO NOT** overstretch retaining rings.

When reinstalling, immerse attaching parts and bolts in transmission fluid. Insert bearings and gaskets with Installation Grease, if necessary stick to the relevant installation areas.

Blow dry all attaching parts — especially the ducts — after using cleaning agents. Function checks are usually carried out with low pressure air (4 bar); use pressure reducing valve and adjust appropriately.

Place new clutch plates and brake bands in transmission fluid for at least two hours before installing.

The installation position of thrust bearings and friction washers can be seen in Fig. 492 at beginning of section "Assemblies, Install in Transmission".

New rubber O-seal rings are identified by their outer and cord diameters; values can be found in Technical Data.

Install housing parts using Sealing Compound.



## Transmission Identification

Identification plate is located on top side of transmission.

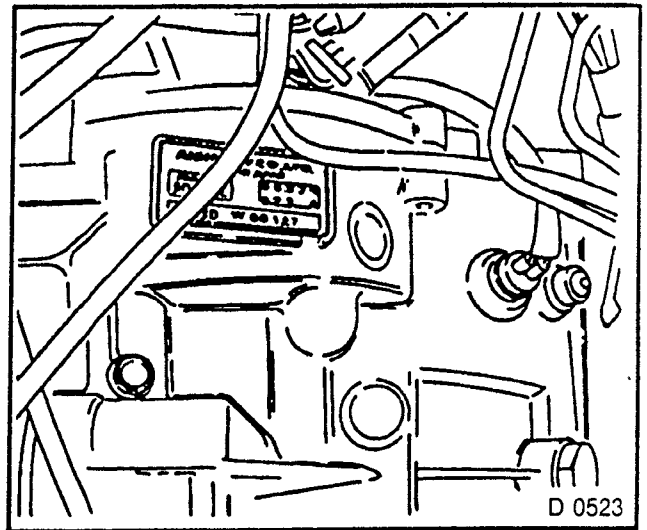


Fig. 218

- 1 = AW transmission type
- 2 = Opel transmission type
- 3 = Model code
- 4 = Opel Parts No.
- 5 = Cal. code
- 6 = Series No.

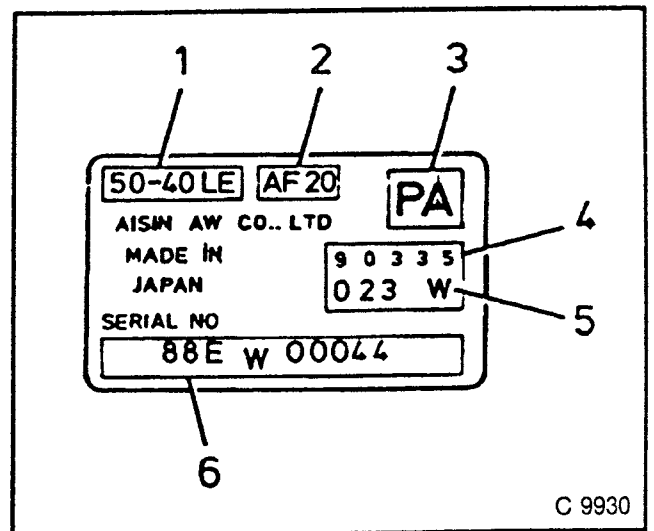


Fig. 219

# CHECKING AND ADJUSTING OPERATIONS

## Transmission Fluid Level — Check

### IMPORTANT!

Selector lever position "P" — maintain during fluid level check, engine 1 to 2 minutes at idle speed.

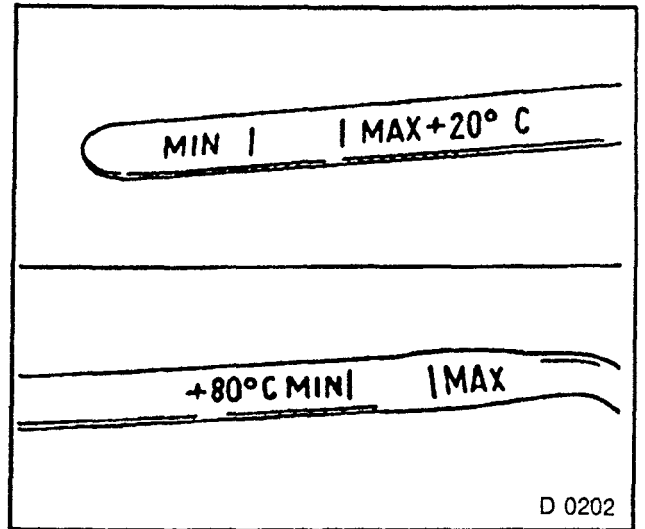


Fig. 220

### MEASURE

Transmission fluid level — with engine running.  
 Note markings on dipstick corresponding to transmission fluid temperature, transmission is at operating temperature after driving approximately 20 km.  
 If necessary (e.g. to inform customer on travelled distance), measure transmission fluid temperature with TECH 1 — see Checking Procedures "Opel Electronic 4-Speed Automatic Transmission AF 14/20", Quick Check from FO: Data List.  
 If necessary, top up with transmission fluid, filling quantity and quality: Technical Data. Fill with engine off.

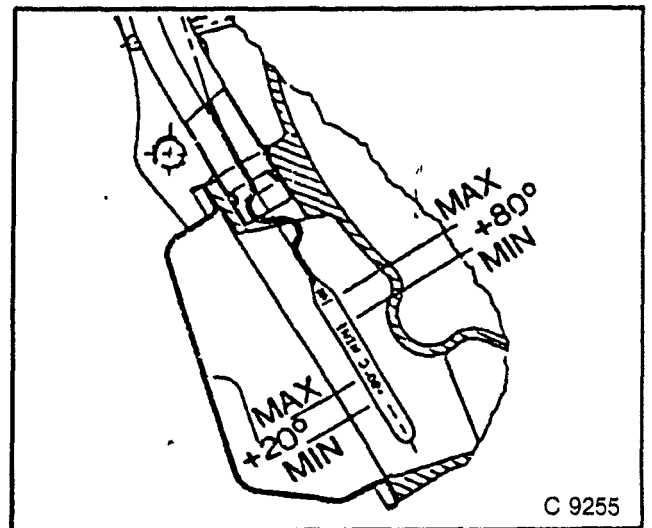


Fig. 221

## Selector Lever Position Switch — Check

### INSPECT

- Functioning of selector lever position switch.
 

| Selector lever position | Function                        |
|-------------------------|---------------------------------|
| P (1), N (2)            | Starting of engine possible     |
| R, D, 3, 2, 1           | Starting of engine not possible |
| R                       | Reversing lamps switched on     |

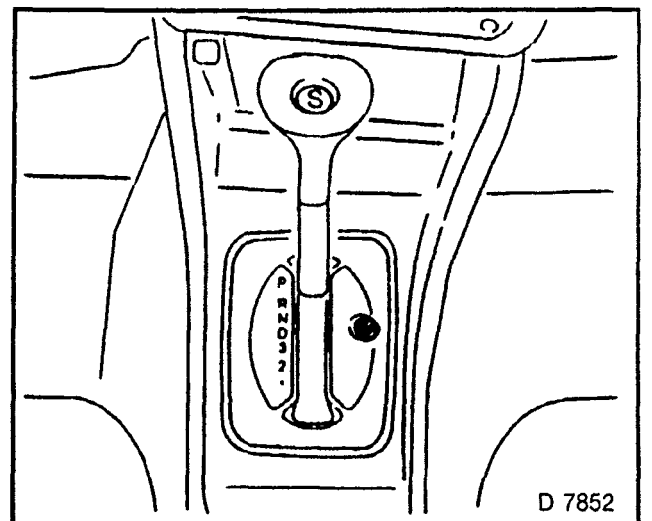


Fig. 222

**WITH INCORRECT FUNCTION:****INSPECT**

1. Selector actuation cable adjustment.
2. Adjustment of selector lever position switch. See operation on Selector lever position switch — electrical functioning. See Checking Procedures "Opel Electronic 4-Speed Automatic Transmission AF 14/20"

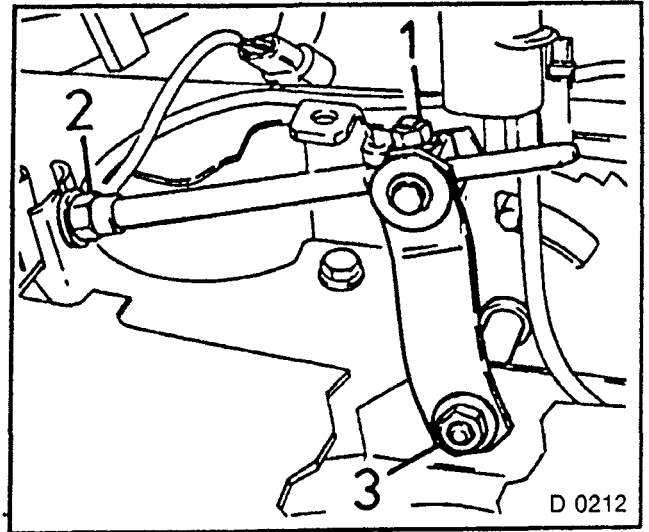


Fig 223

## Selector Lever Position Switch — Adjust

**REMOVE, DISCONNECT**

1. Bowden cable from actuation lever — remove retaining clamp and remove Bowden cable.
2. Bring selector lever shaft into neutral position by turning actuation lever. Turn first to right stop, then turn back two notches ("P", "R", "N").

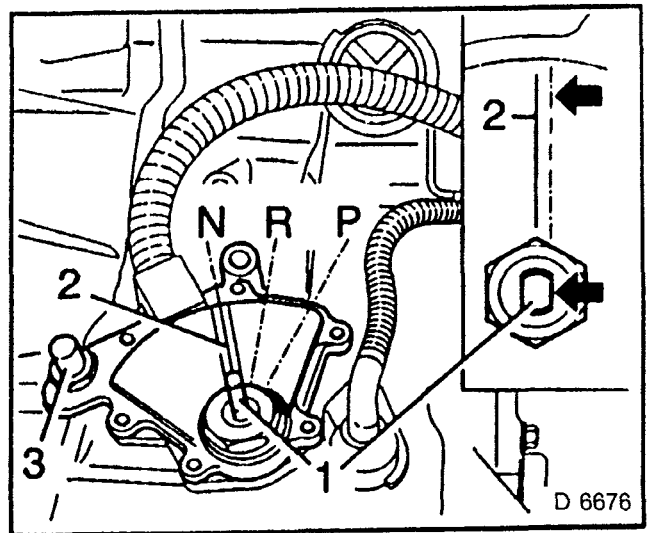


Fig 224

3. The flattened part of the selector lever shaft (1) must align with the split (2) in the selector lever position switch housing (arrows).
4. For correct adjustment, loosen the stop screw (3)
5. Turn selector lever position switch so that split aligns with flattened part of selector lever shaft (1).
6. Tighten stop screw — 25 Nm.

**INSTALL, CONNECT**

1. Bowden cable to actuation lever — secure with clamp.

## Fluid Pressure Check (Mechanical)

**NOTE:**  
CHECK TRANSMISSION FLUID LEVEL.  
ELIMINATE POSSIBILITY OF OPERATING FAULT.

Full load check values measured at an engine speed of 2500 + 150 rpm. For full load checks, engage parking brake and depress service brake. DO NOT check for longer than five seconds, due to risk of overheating. Allow pauses for cooling.

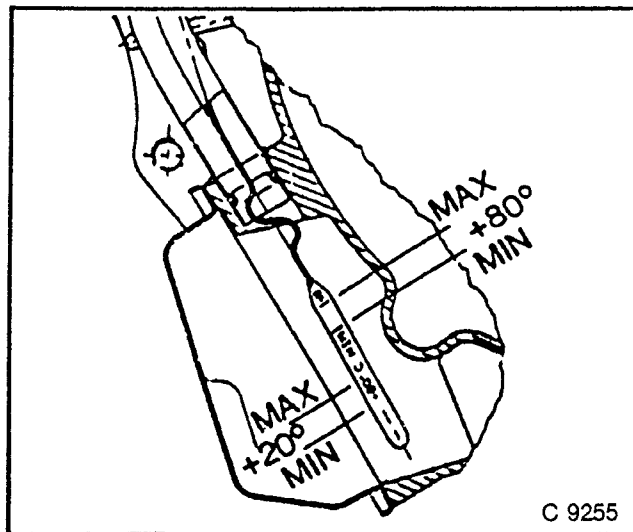


Fig. 225

### INSPECT

1. Main pressure with KM-580 or KM-498-B.
2. Unscrew plug M 8 above joint of left axle shaft on transmission side and connect adapter.
3. Selector lever position
 

|            | Idle speed    | Full load       |
|------------|---------------|-----------------|
| R          | 5.0 — 5.8 bar | 17.0 — 19.0 bar |
| D, 3, 2, 1 | 2.6 — 3.0 bar | 11.4 — 12.6 bar |
4. Screw in plug M 8 — 8 Nm.  
Checking values: See also Checking Procedures (Opel Electronic 4-speed Automatic Transmission AF 14/20).

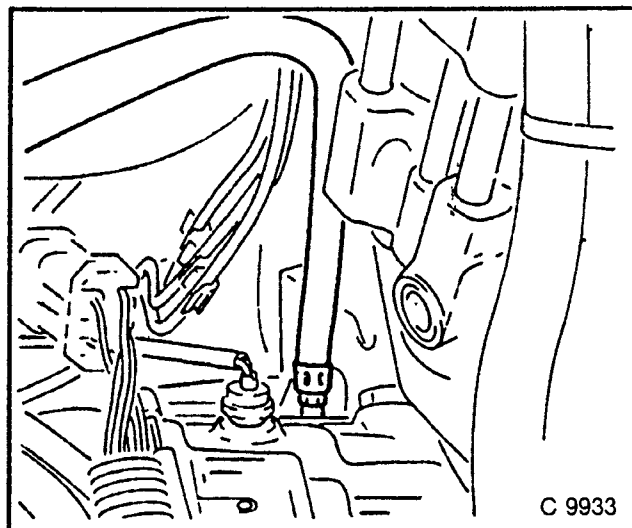


Fig. 226

### INSPECT

1. Fluid circuit C1 with KM-580 and KM-498-B, connect as shown in illustration.
2. Selector lever position
 

|            | Idle speed | Full load |
|------------|------------|-----------|
| R          | 0 bar      | 0 bar     |
| D, 3, 2, 1 | 2.8 bar    | 12 bar    |

Checking values: See also Checking Procedures (Opel Electronic 4-speed Automatic Transmission AF 14/20) and section "Technical Data".
3. Screw in plug M 8 — 8 Nm.

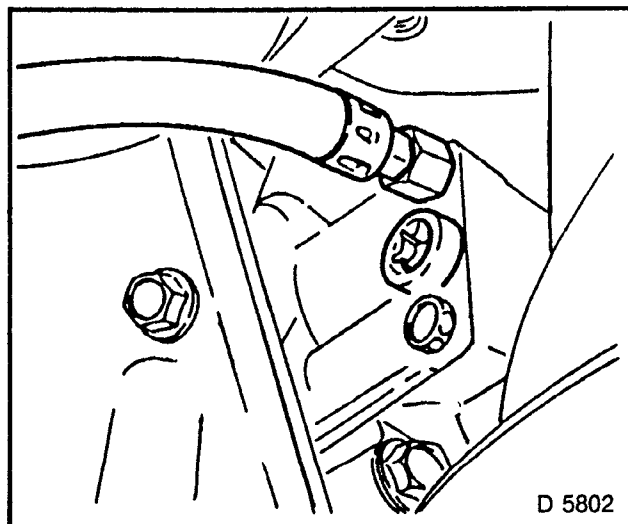


Fig. 227

4. Fluid circuit C2 with KM-498-4 and KM-498-A or KM-498-B, connection as in Fig. 227, however screw in adapter in Torx bolt bore hole (Torx insert T 55 or MKM-604-22) below connection C1.

5. Selector lever position

|            | Idle speed | Full load |
|------------|------------|-----------|
| R          | 5.0 bar    | 18.0 bar  |
| D, 3, 2, 1 | 0 bar      | 0 bar     |

Checking values: See also Checking Procedures (Opel Electronic 4-speed Automatic Transmission AF 14/20).

6. Screw in Torx bolt — 35 Nm.

## INSPECT

1. Fluid circuit B4 — connect as in Fig. 228.

2. Selector lever position

|            | Idle speed | Full load |
|------------|------------|-----------|
| R          | 5.0 bar    | 18.0 bar  |
| D, 3, 2, 1 | 2.8 bar    | 12.0 bar  |

Checking values: See also Checking Procedures (Opel Electronic 4-speed Automatic Transmission AF 14/20).

3. Screw in plug — 35 Nm..

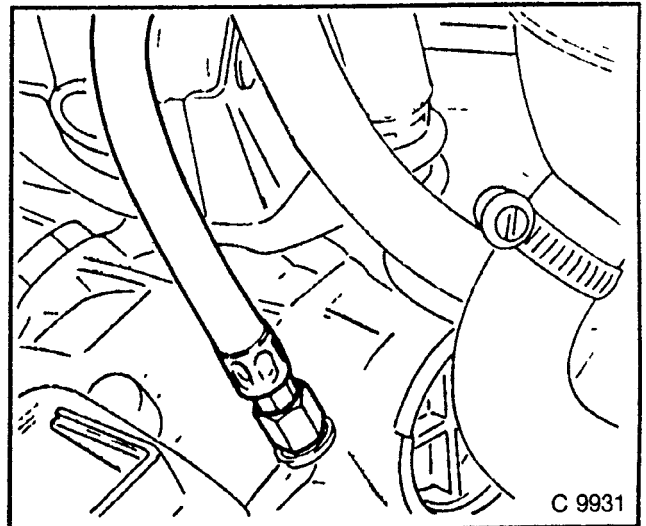


Fig 228

## OPERATIONS ON INSTALLED TRANSMISSION

### Electronic Control Unit — Remove and Install

#### REMOVE, DISCONNECT

1. Control unit.
2. Glove compartment, completely — see section C.
3. Disconnect wiring harness plug (1), unclip control unit from bracket (2).

#### INSTALL, CONNECT

1. Control unit.
2. Clip into bracket (2).
3. Connect wiring harness plug (1).
4. Install glove compartment.

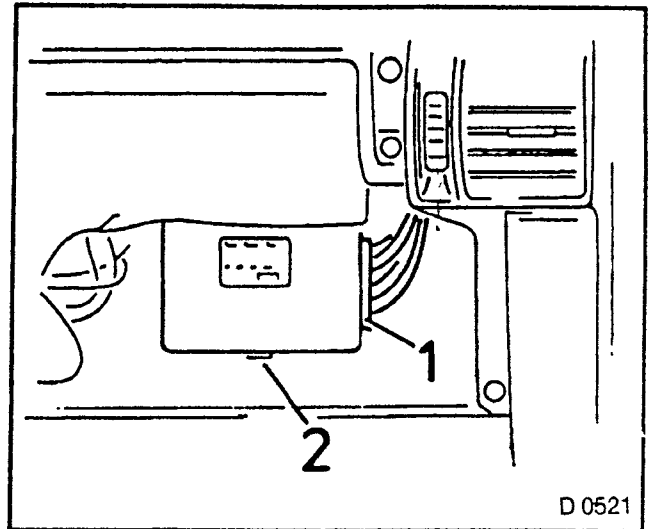


Fig. 229

### Selector Actuation Cable — Adjust

#### INSPECT

- 1 Adjustment of selector auction cable.
2. Put selector lever consecutively into positions "P, R, N, D, 3, 2, 1" — lift pull knob up to first or second stop.
3. The auction lever on transmission must catch at each of the following: "P" (foremost position, 1), "R", "N" (2), "D", "3", "2", "1".

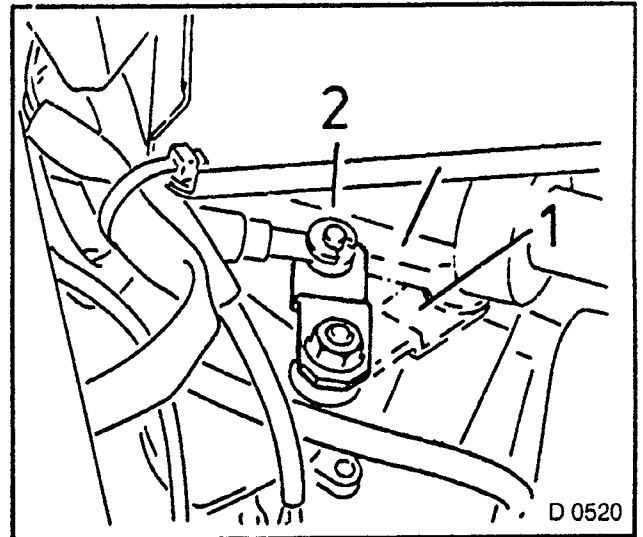


Fig. 230

If actuation lever does not catch:

### REMOVE, DISCONNECT

1. Unclip shift cover from shift tunnel — by pressing on the surface marked by arrows — and turn until aperture for cable clamp is visible.

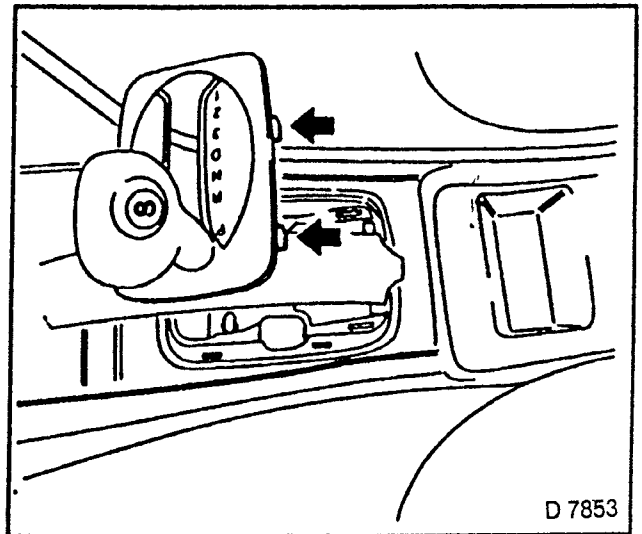


Fig. 231

### ADJUST

1. Selector actuation Bowden cable (Fig. 232B) — centre console removed.
2. Loosen cable clamp bolt (1) — guide box spanner through aperture (Fig. 232A).
3. Selector lever in position "P", ensure by moving selector lever forwards and backwards without lifting pull knob that lever correctly catches in position "P".
4. Turn actuation lever on transmission right (towards battery holder) as far as stop (Fig. 230 Item 1) — must catch.
5. Turn at the front wheels so that parking pawl in transmission correctly catches.

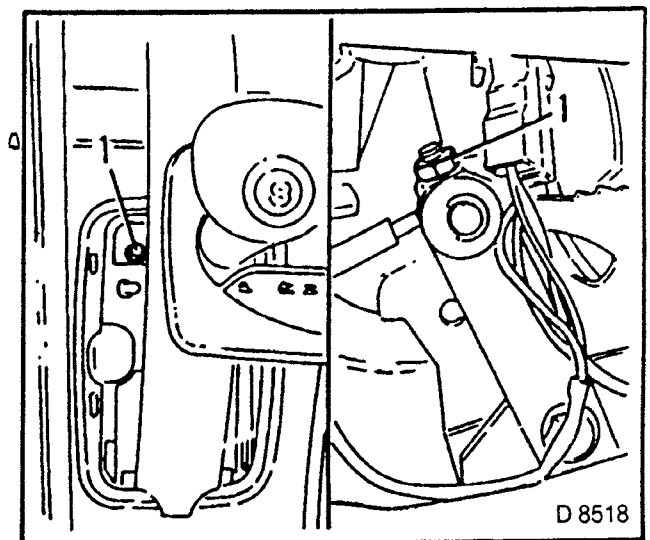


Fig. 232

### TIGHTEN (TORQUE)

1. Cable clamp bolt — 6 Nm

Check as described above. See operation "Selector Lever Position Switch, Check" page 106.

### INSTALL, CONNECT

1. Clip shift panel to shift tunnel.

## Kickdown Switch — Adjust

### INSPECT

1. Cable adjustment
2. Depress accelerator until kickdown system point of contact is reached — throttle valve must be fully opened: accelerator must actuate kickdown switch centrally.
3. Depress accelerator past point of contact — kickdown switch should release electrical contact in control unit.
4. Electronic transmission control system shifts down at appropriate speed — Technical Data, dynamometer or test drive.
5. When accelerator is at idle position — adjust cable to intake manifold idle stop without play.

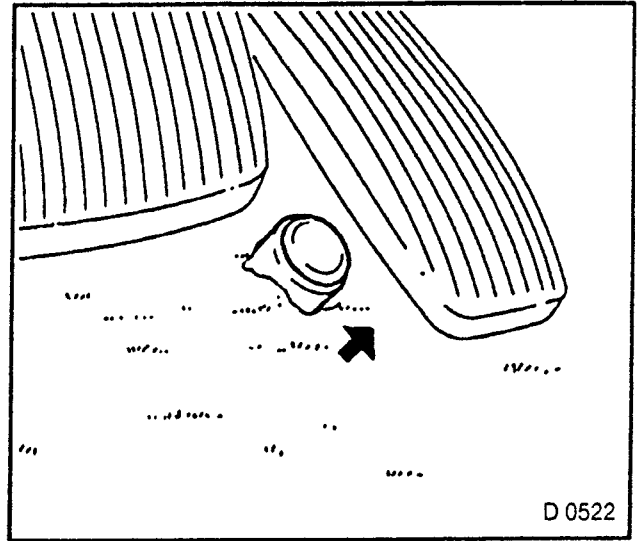


Fig. 233

## Solenoid Valves or Fluid Pressure Regulator — Remove and Install

### REMOVE, DISCONNECT

1. Side cover from transmission.
2. Solenoid valve 2 — 3 (1).
3. Solenoid valve 1 — 2/3 — 4 (2).
4. Fluid pressure regulator (3) — remove retaining clip.
5. Bridge clutch solenoid valve (4).
6. Disconnect affected wiring harness plug, if necessary loosen from cable retainer.
7. Electrically check solenoid valves — see "Valve Body, Overhaul" at end of section "Assemblies, Disassemble and Assemble", pages 151 and 199.

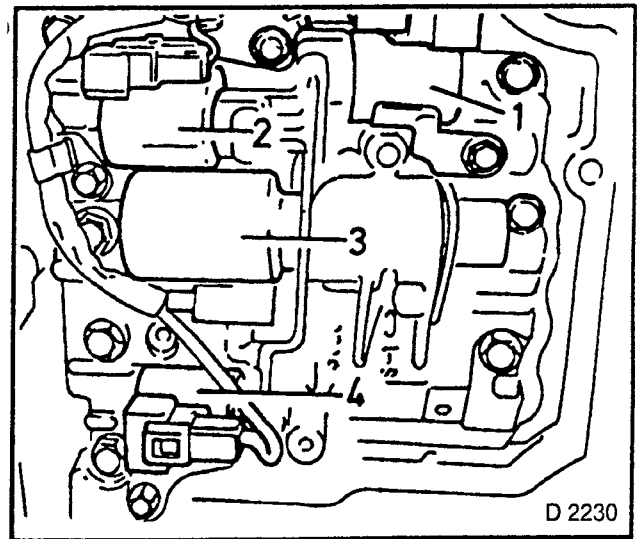


Fig. 234

**NOTE:**  
**THE PRESSURE REGULATOR IS NOT AVAILABLE AS A SINGLE PART AND IF DEFECTIVE MUST BE REPLACED TOGETHER WITH THE VALVE BODY.**

### TIGHTEN (TORQUE)

1. Solenoid valves with new rubber O-seal rings to valve body — 7 Nm.
2. Side cover to transmission.
3. Check fluid level and correct — page 106.



## Solenoid Valve Wiring Harness — Replace

### REMOVE, DISCONNECT

1. Side cover from transmission.
2. Retaining plate for wiring harness beside selector lever position switch.
3. Wiring harness plug from solenoid valves or fluid pressure regulator.
4. Wiring harness plug (outer) from transmission wiring harness.
5. Remove wiring harness from cable retainer and guide outwards.

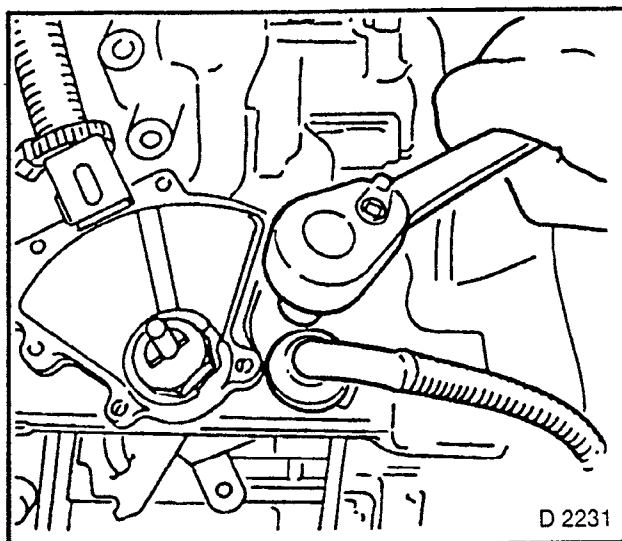


Fig. 235

### INSTALL, CONNECT

1. Install wiring harness from outside inwards using new rubber O-seal ring.
2. Insert wiring harness in cable retainer (1), connect to solenoid valves (2) or fluid pressure regulator (3) (different cable lengths).
3. Wiring harness plug (outer) to transmission wiring harness.

### TIGHTEN (TORQUE)

1. Retaining plate for wiring harness to transmission — 13 Nm.
2. Install side cover, check fluid level.

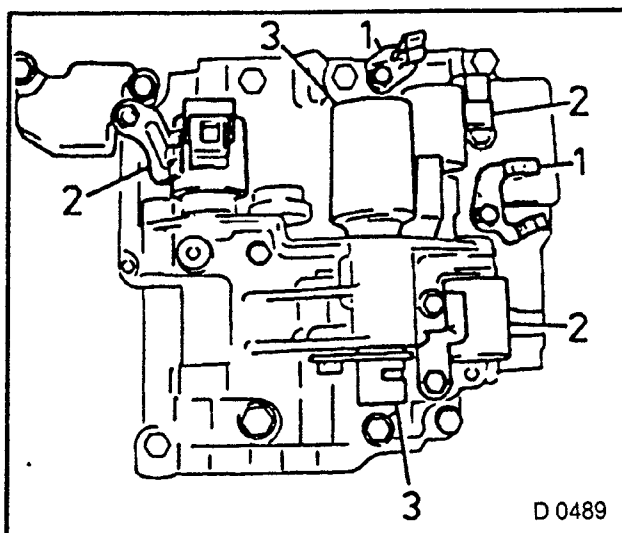


Fig 236

## Axle Shaft Seal Rings — Replace

1. Hold engine with KM-263-A and spring hooks.
2. Disconnect oxygen sensor cable connection (behind coolant expansion tank).

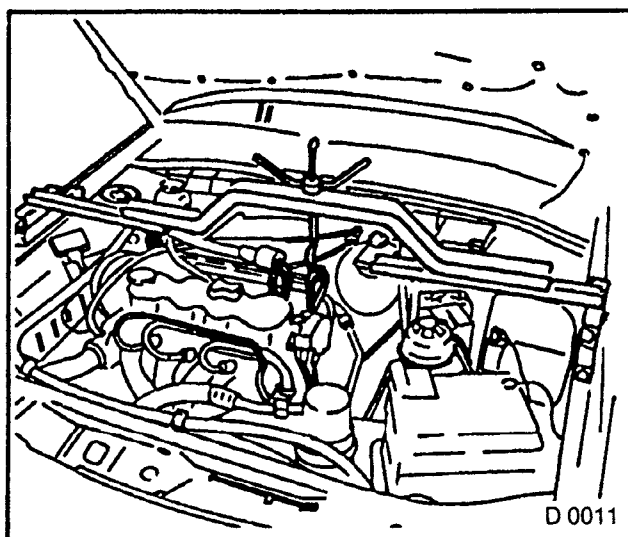


Fig. 237

**REMOVE, DISCONNECT**

1. Ground lead from battery, front wheels.
2. Front exhaust pipe, front axle body — see Section E or Section L.

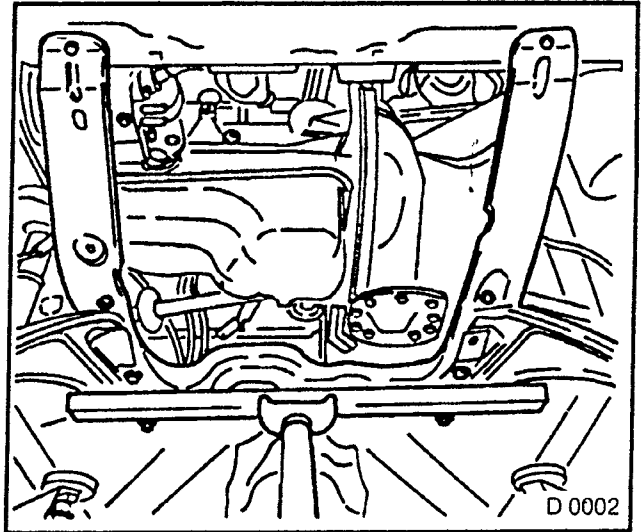


Fig 238

**REMOVE, DISCONNECT**

1. Axle shafts from transmission — see "Transmission, Remove and Install", page 128.
2. Sealing rings from transmission — KM-557.

**INSTALL, CONNECT**

1. Drive in new seal rings flush — KM-519. If necessary push left spring strut to one side.
2. Axle shafts.
3. Front axle body.
4. Front wheels
5. Oxygen sensor cable connection.
6. Remove KM-263-A.

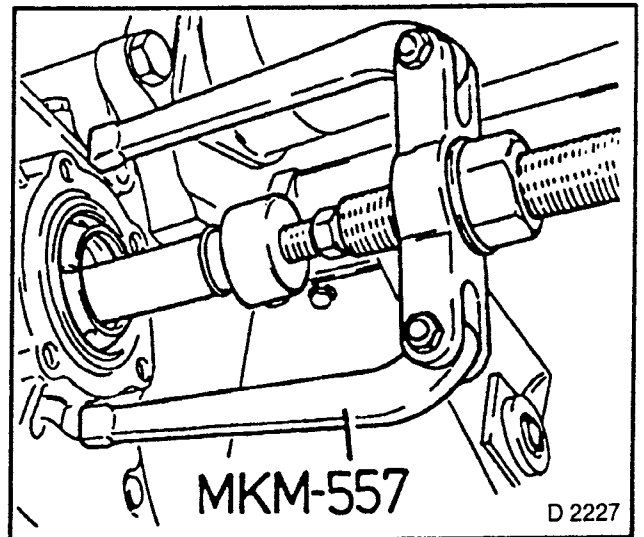


Fig. 239

**INSPECT**

1. Transmission fluid level.

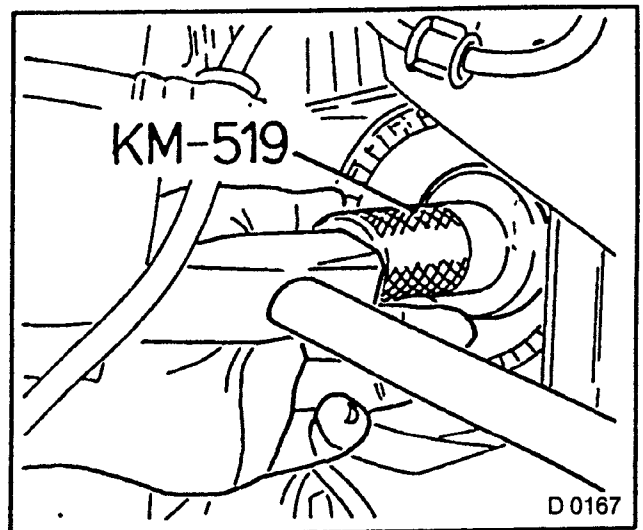


Fig. 240

## Fluid Filler Pipe and/or Gasket — Replace

### REMOVE, DISCONNECT

1. Fluid dipstick.
2. Fluid filler pipe — loosen fastening bolt on selector lever position switch; remove pipe upwards
3. Replace rubber O-seal ring.

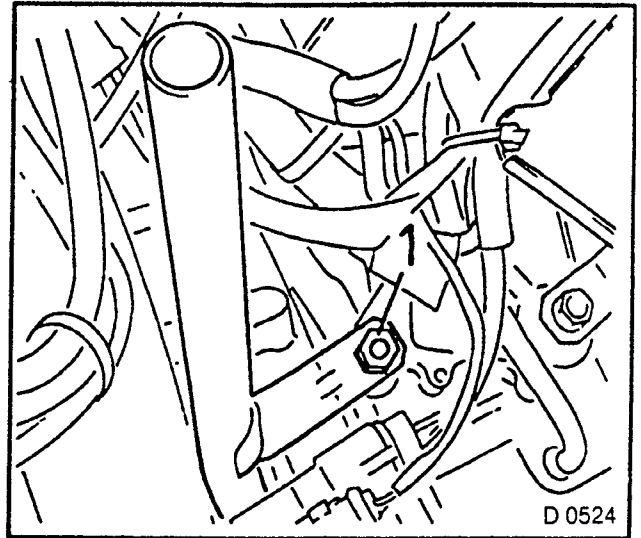


Fig. 241

### INSTALL, CONNECT

1. Fluid filler pipe in transmission — coat rubber O-seal ring and area of press fit in housing bore with installation grease.
2. Press in pipe as far as stop, if necessary assist by lightly tapping with plastic hammer.

### TIGHTEN (TORQUE)

1. Fastening bolt of fluid filler pipe to selector lever position switch — 20 Nm.
2. Insert dipstick.

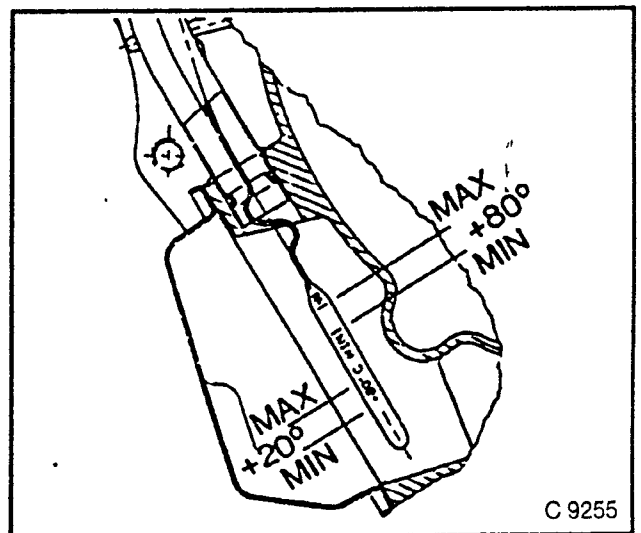


Fig. 242

## Speedometer Helical Gear (Driven) and/or Seal Ring — Replace

### REMOVE, DISCONNECT

1. Speedometer cable.
2. Speedometer helical gear.
3. Seal ring from groove.

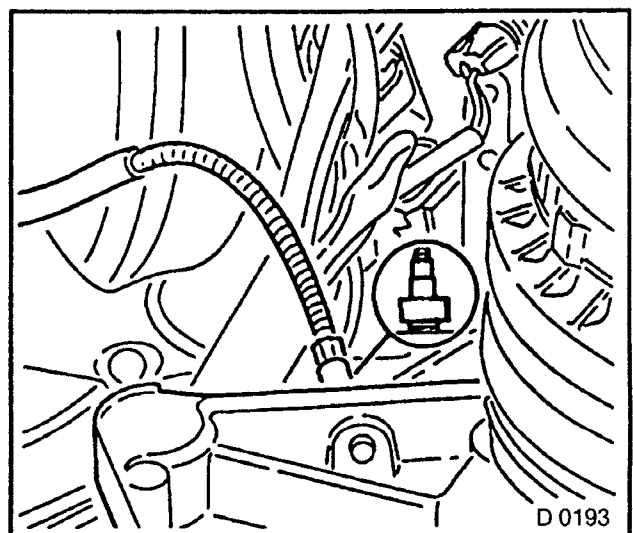


Fig. 243

**INSTALL, CONNECT**

1. New seal ring in groove.
2. Speedometer helical gear, lubricate splines with installation grease.

**TIGHTEN (TORQUE)**

1. Speedometer helical gear to transmission — 4 Nm.

**INSTALL, CONNECT**

1. Speedometer cable.

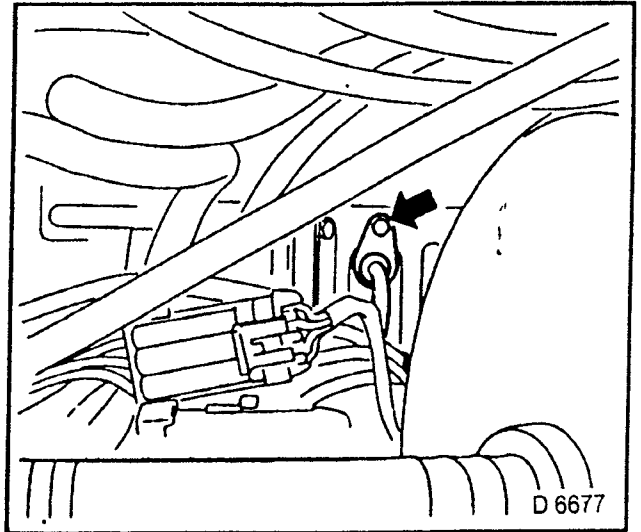


Fig. 244

**Sensor — Transmission Input/Output Speed — Remove and Install****REMOVE, DISCONNECT**

1. Torx bolt for transmission input speed sensor (1).
2. Torx bolt for transmission output speed sensor (2).
3. Replace seal ring.

**TIGHTEN (TORQUE)**

1. Torx bolt for sensor to transmission — 6 Nm.

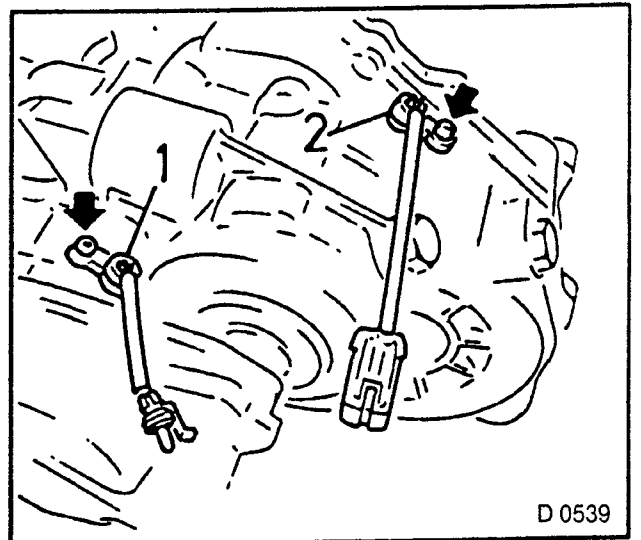


Fig. 245

**Fluid Temperature Sensor and/or Gasket — Replace****REMOVE, DISCONNECT**

1. Cover plate from side cover and transmission (1), replace seal ring.
2. Fluid temperature sensor (arrow).

**TIGHTEN (TORQUE)**

1. Fluid temperature sensor to transmission — 25 Nm.
2. Cover plate to side cover — 25 Nm.

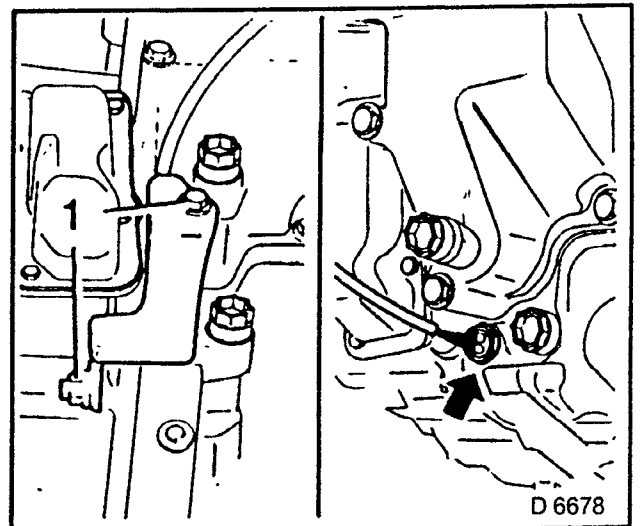


Fig. 246

## Fluid Cooler Lines, Connecting Hose and/or Seal Rings — Replace

### REMOVE, DISCONNECT

1. Fluid cooler lines (2) from fluid cooler or transmission.
2. Loosen connecting hoses at hose clamps (1) and remove — fluid escapes.
3. Replace seal rings.

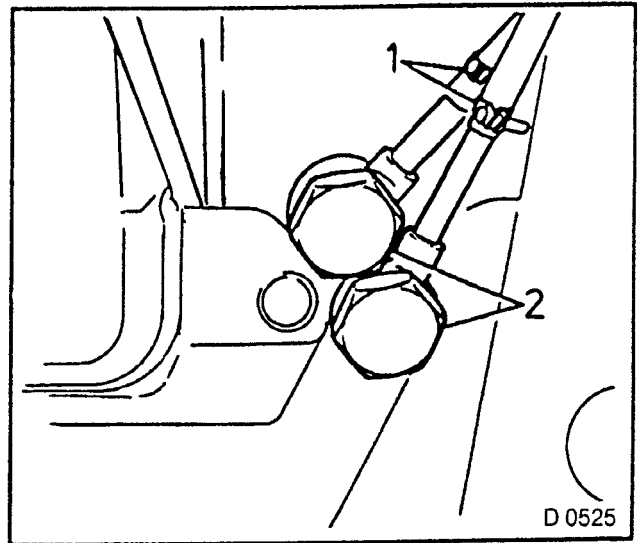


Fig 247

### NOTE:

NOTE INSTALLATION POSITION OF FLUID COOLER LINES, SO THAT THE CONNECTING HOSES CAN BE INSTALLED WITHOUT KINKING OR TWISTING.

ALLOW FOR TILTING MOTION OF ENGINE.

### TIGHTEN (TORQUE)

1. Fluid cooler lines (2) with new seal rings to fluid cooler or transmission — 22 Nm.
2. **DO NOT** turn too much — cooler housing is made of plastic.
3. Hose clamps (1) to connecting hoses — 1.2 Nm align without kinking and twisting.

## Seal Rings for Check Bore (Fluid Pressure) — Replace

### REMOVE, DISCONNECT

1. Affected plug — fluid escapes.
2. Replace seal ring.

### TIGHTEN (TORQUE)

1. Plug M 8 (1) to transmission — 8 Nm.
2. Plug M 14 (2) to transmission — 35 Nm.
3. Plug M 18 (3) to transmission — 35 Nm.
4. Plug M 20 (4) to transmission — 35 Nm.

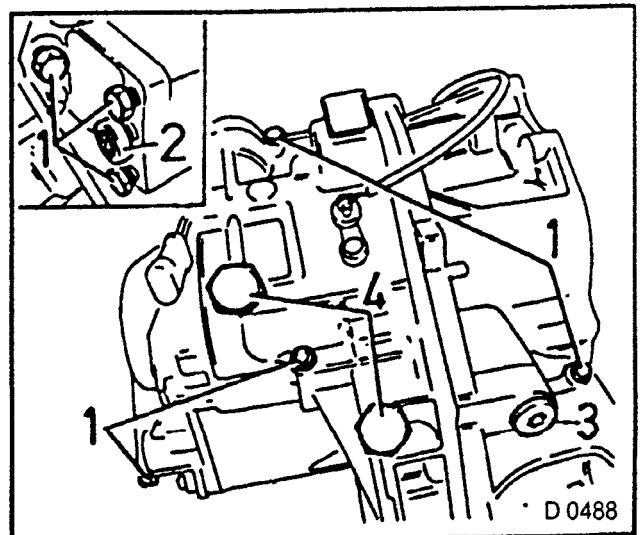


Fig. 248

## Auxiliary Housing Cover and/or Gasket — Replace

### REMOVE, DISCONNECT

1. Cover plate from side cover.
2. Auxiliary housing cover.

### CLEAN

1. Sealing surfaces on cover and transmission.

### TIGHTEN (TORQUE)

1. Cover to transmission — 5 Nm. Insert with Sealing Compound (Loctite 242).
2. Cover plate to side cover — 25 Nm.

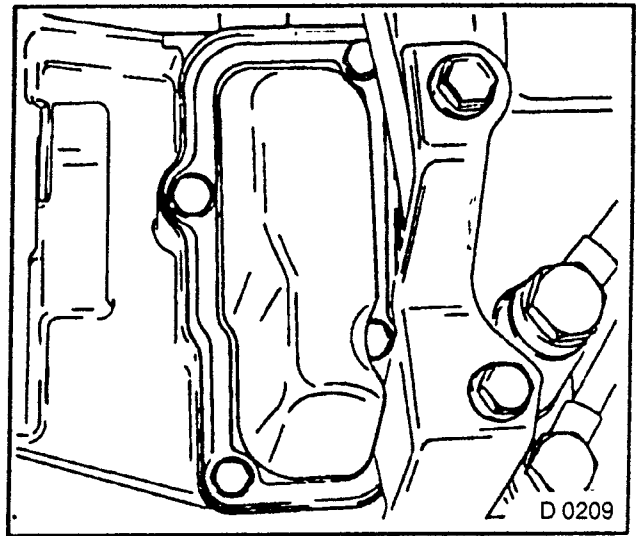


Fig. 249

## Gasket for Side Cover — Replace

Hold engine with KM-263-A and spring hook.

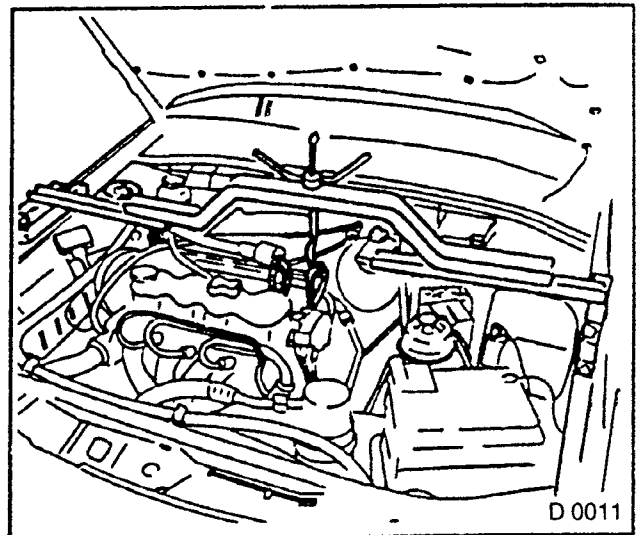


Fig. 250

### REMOVE, DISCONNECT

1. Ventilation pipe from transmission — under battery bracket.
2. Fluid line from side cover or transmission.
3. Fluid escapes — close off lines.
4. Front left engine suspension bracket from transmission and front frame side member.

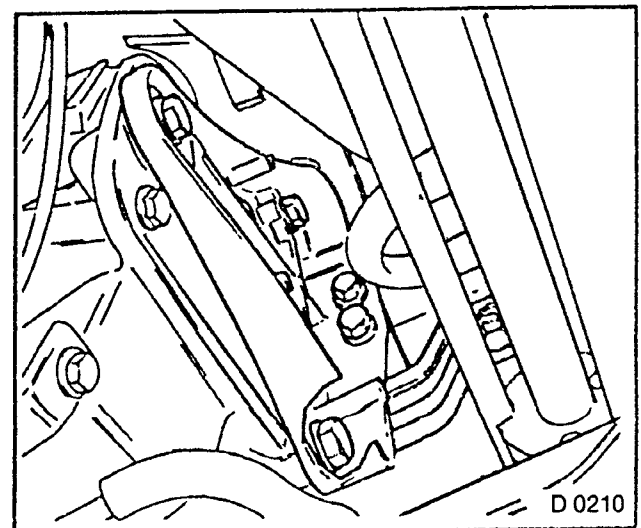


Fig. 251

**REMOVE, DISCONNECT**

- 1 Side cover from transmission (nine bolts)  
— fluid escapes.
2. One guide bushing present.

**CLEAN**

1. Sealing surfaces on cover and transmission.

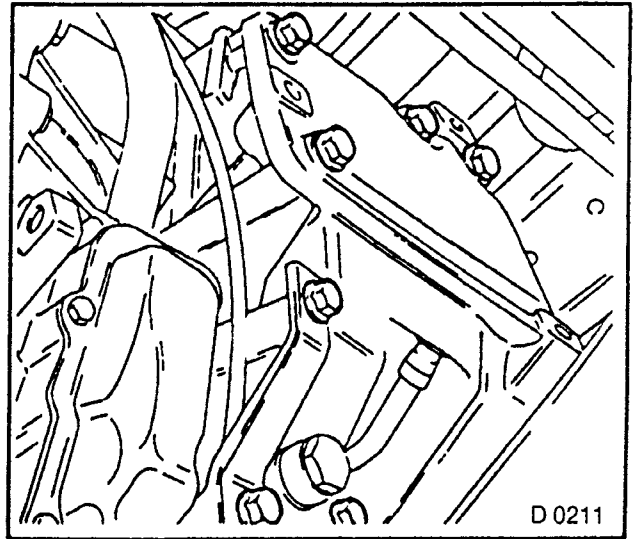


Fig. 252

**TIGHTEN (TORQUE)**

1. Cover to transmission — 25 Nm. Insert with Sealing Compound.
2. Front left engine suspension bracket to transmission — 65 Nm.
3. Front left engine suspension bracket to front frame side member — 75 Nm (Two new bolts).
4. Lower fluid cooler line — 22 Nm, note installation position, so that the connecting hose can be routed without kinking or twisting.

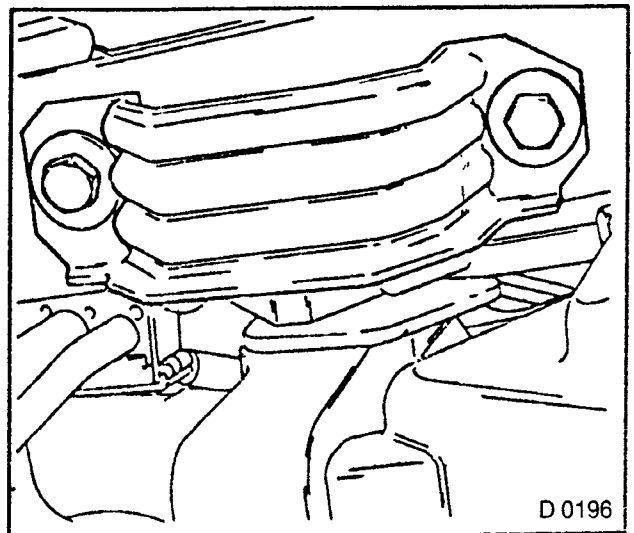


Fig. 253

**TIGHTEN (TORQUE)**

1. Hose clamp to connecting hose — 1.2 Nm or if removed:
2. Fluid cooler line connections to transmission and side cover — 22 Nm. Fluid escapes.
3. Remove KM-263-A, attach ventilation hose.
4. Check transmission fluid level.

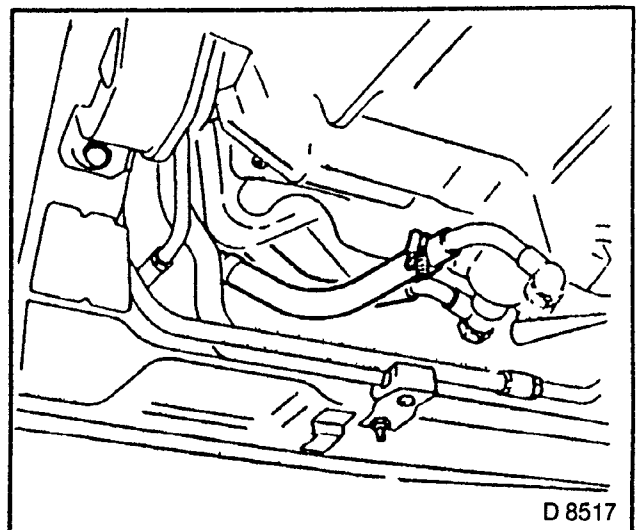


Fig. 254

## OPERATIONS ON TRANSMISSION SHIFT LINKAGE

### Bulb/Socket for Lighting — Remove and Install

#### REMOVE, DISCONNECT

1. Selector lever cover from gearshift tunnel — see page 122. "Selector Actuation Cable. Remove and Install".
2. Bulb with socket from switch cover.

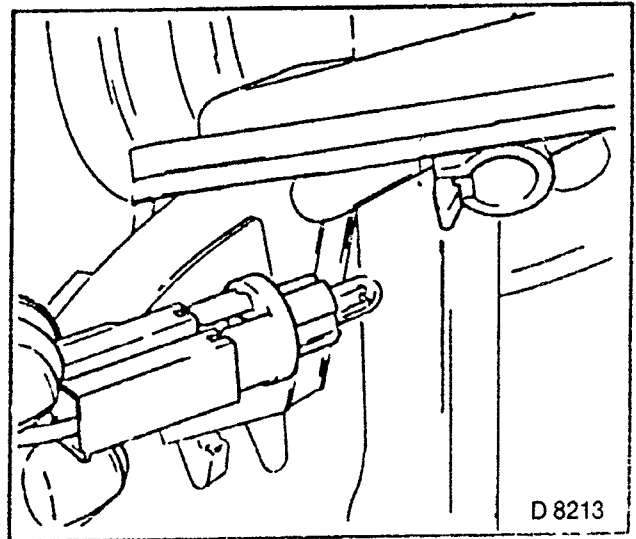


Fig. 255

#### INSTALL, CONNECT

1. Bulb/socket.
2. Selector lever cover.

### Driving Mode Switch — Remove and Install "Winter" Mode

#### REMOVE, DISCONNECT

1. Selector lever cover from shift tunnel — see page 122. "Selector Actuation Cable, Remove and Install".
2. Switch from switch cover — disconnect wiring harness plug.

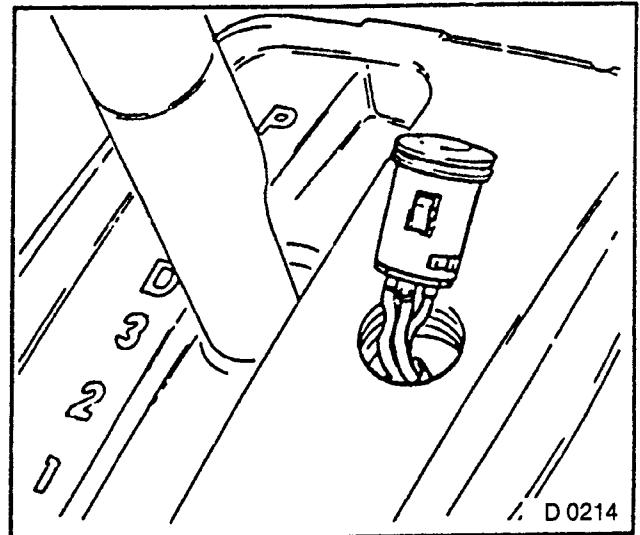


Fig. 256

#### INSTALL, CONNECT

1. Wiring harness plug.
2. Switch.
3. Selector lever cover.



## “Sport” Mode

### REMOVE, DISCONNECT

1. Selector lever.  
“Selector Lever Assembly, Remove and Install” — page 123.
2. Press out driving mode switch with electrode wire (1).
3. Solder cables (2).

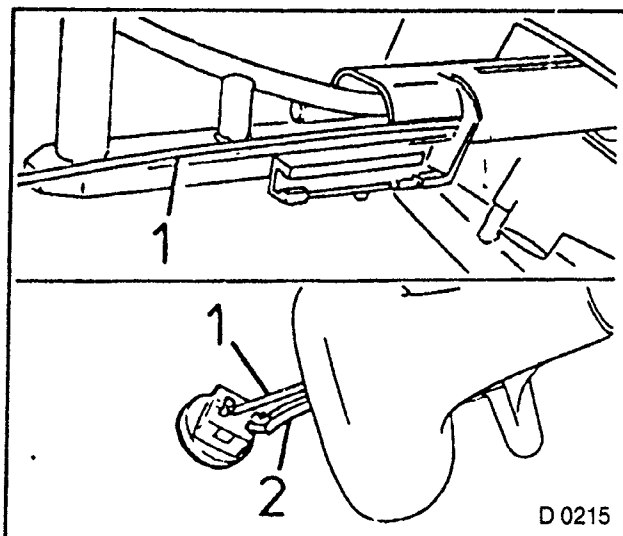


Fig. 257

## Kickdown Switch — Remove and Install

1. Loosen carpet bracket on the left under the accelerator pedal.
2. Fold back carpet.
3. Remove two-pin wiring harness plug.
4. Remove kickdown switch upwards from bracket (arrow).

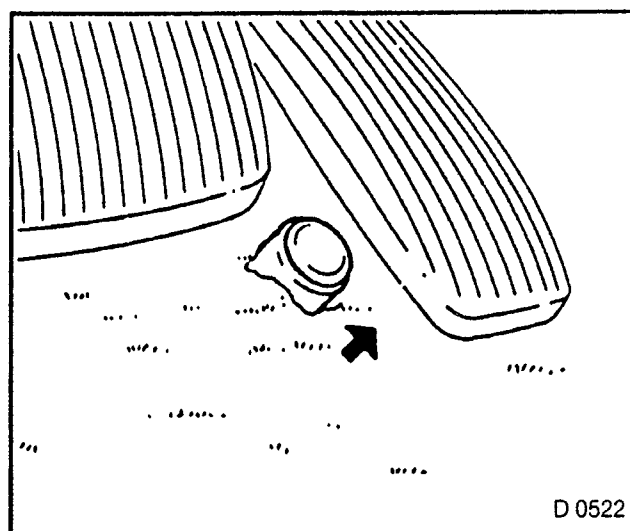


Fig. 258

### INSTALL, CONNECT

1. Guide two-pin wiring harness plug through aperture in carpet.
2. Connect.
3. Press kickdown switch down to stop on bracket.
4. Fasten carpet bracket.
5. Accelerator pedal must actuate kickdown switch centrally
6. Adjust kickdown switch.

## Selector Actuation Cable — Remove and Install

### REMOVE, DISCONNECT

1. Cable from selector actuation.
2. Retaining clamp and washer from actuation lever on transmission.
3. Fastening nuts from bracket for cable on transmission.

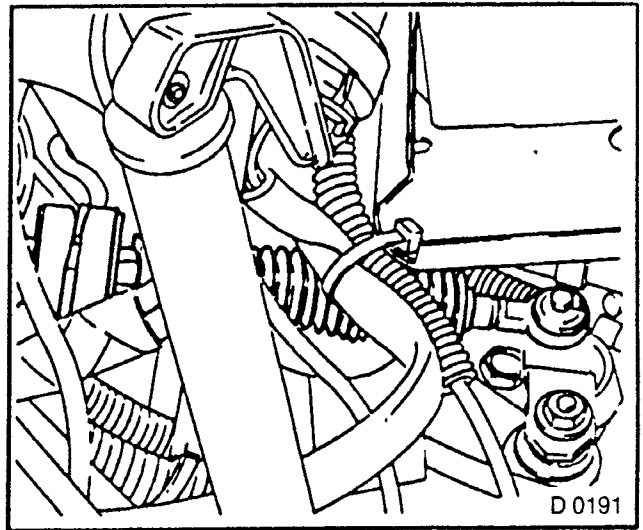


Fig. 259

### REMOVE, DISCONNECT

1. Selector lever cover from shift tunnel.
2. Centre console — see Section C.

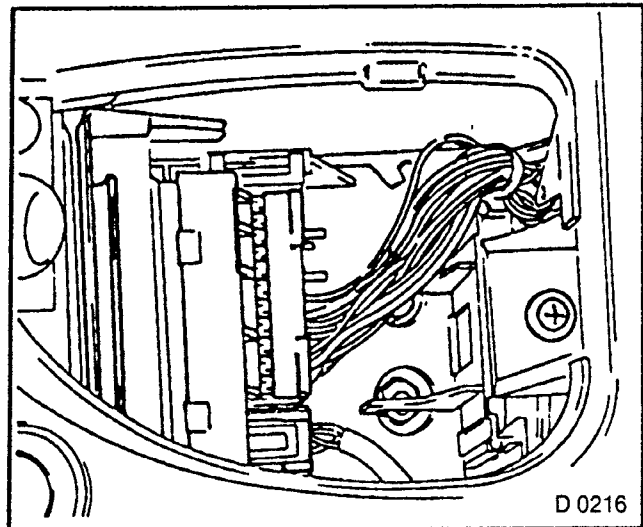


Fig. 260

### REMOVE, DISCONNECT

1. Cable from selector lever and console (1, 2).
2. Loosen clamp (1), retaining nut (2) from threaded part.
3. Pull out cable to engine compartment through bulkhead.

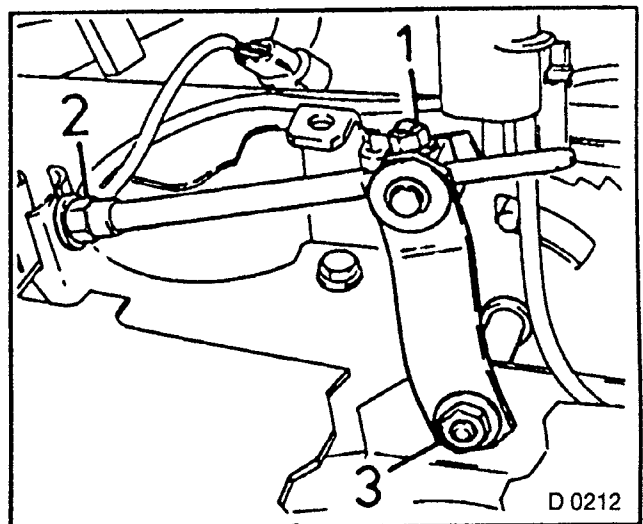


Fig. 261

## INSTALL, CONNECT TIGHTEN (TORQUE)

1. Cable to actuation lever and also to console and selector lever  
Note correct positioning of rubber sleeve in bulkhead.  
Cable to console — 6 Nm.
2. Adjust selector lever.

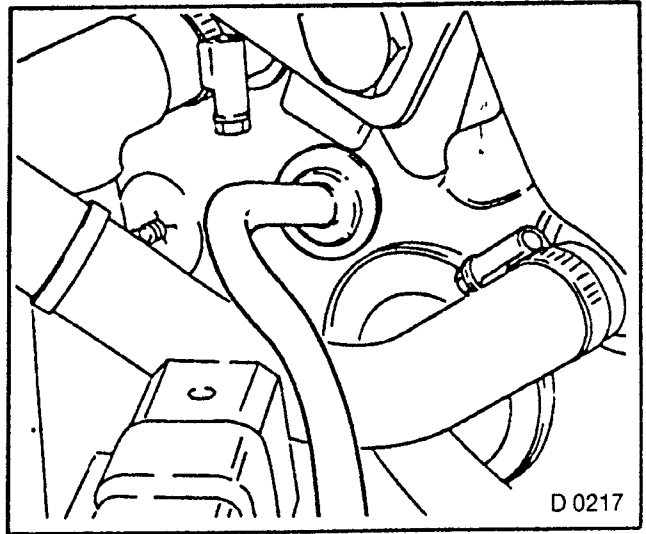


Fig. 262

## Selector Lever Assembly — Remove and Install

### REMOVE, DISCONNECT

1. Selector lever cover from shift tunnel — see "Selector Actuation Cable, Remove and Install" page 122.
2. Cable from selector lever and console (1, 2).
3. Cable plug from driving mode switches "Winter" and "Sport".
4. Lighting socket from shift panel.

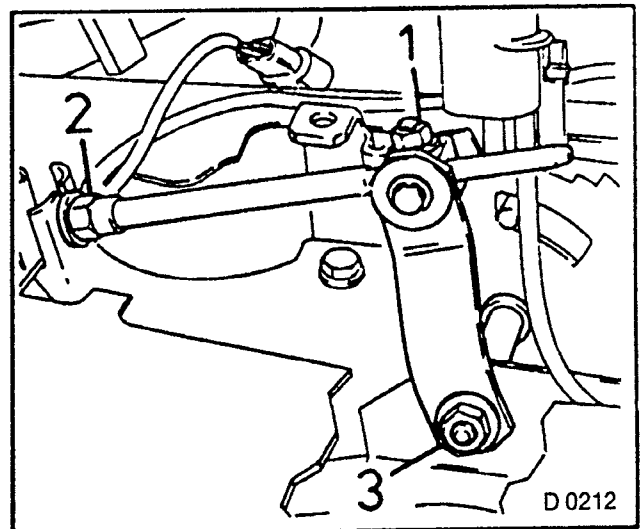


Fig. 263

### REMOVE, DISCONNECT

1. Selector lever from console.
2. Unbolt lever from selector lever axle (Fig. 263 Item 3).
3. Remove selector lever sideways from position in console.

**DISASSEMBLE**

1. Selector lever.
2. Driving mode switch "Winter" from shift panel.
3. Driving mode switch "Sport" from selector lever.
4. Press out with electrode wire (1).
5. Unsolder cable connections (2) — mark.

**Do not** disassemble selector lever further; spare part is only available in assembly with shift panel.

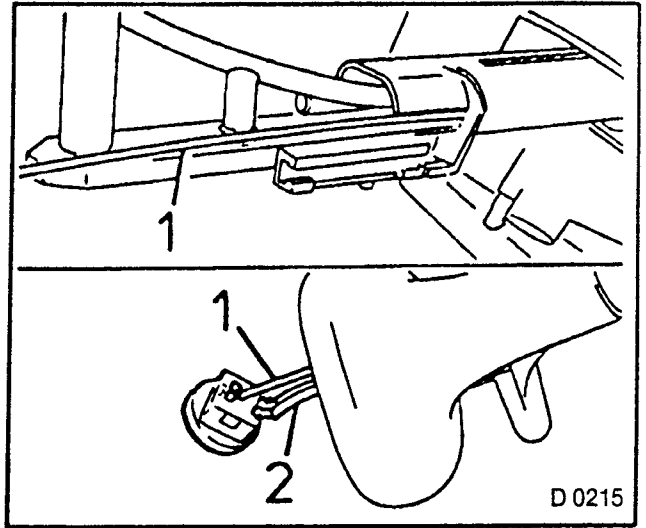


Fig. 264

**INSTALL, CONNECT**

1. Solder cable connections for driving mode switch "Sport" — mark.

**TIGHTEN (TORQUE)**

1. Selector lever to console (3) 28 Nm.
2. Cable to console (2) — 6 Nm.
3. Adjust selector actuation.

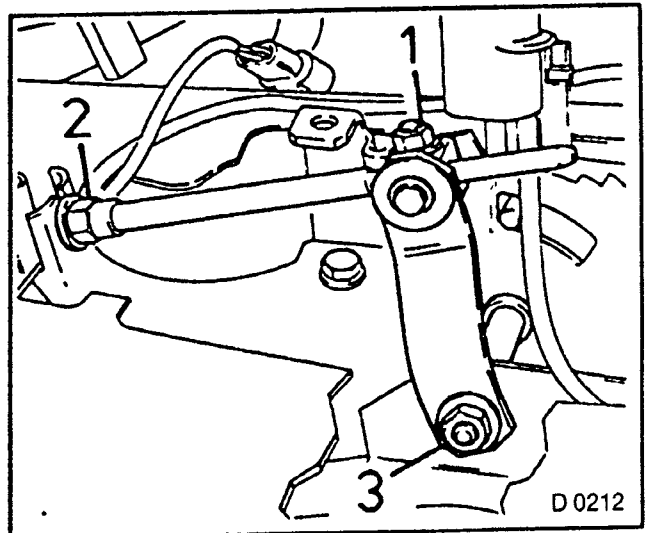


Fig. 265

**Selector Lever Console — Remove and Install****REMOVE, DISCONNECT**

1. Selector lever from console
2. See "Selector Lever Assembly, Remove and Install", page 123.  
Disassembly operations on selector lever do not apply.
2. Console from floor panel — four screws.

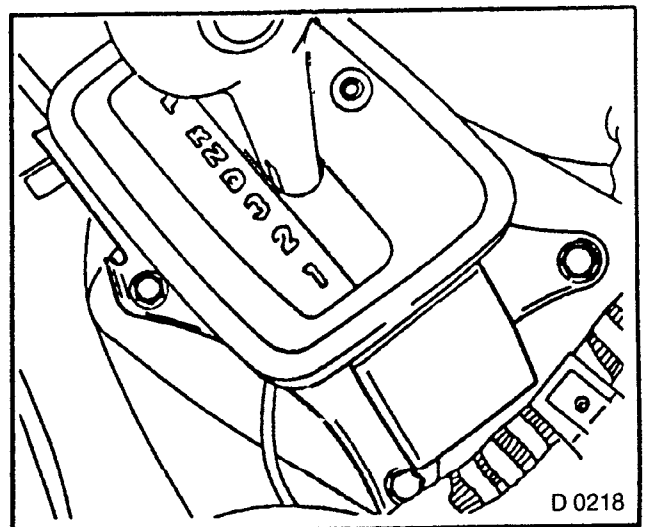


Fig 266

**TIGHTEN (TORQUE)**

1. Console to floor panel — 10 Nm.
2. Cable to console (2) — 6 Nm.
3. Install cable on clamp — **DO NOT** tighten yet.
4. Adjust selector actuation

**INSTALL, CONNECT**

1. Selector lever cover.

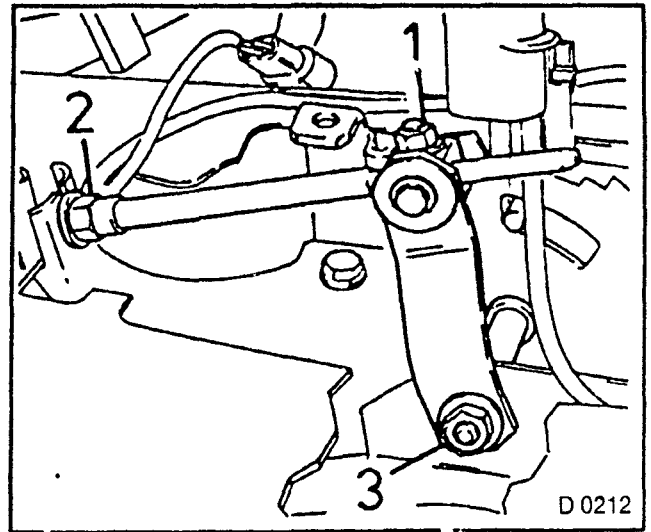


Fig. 267

## OPERATIONS ON REMOVED TRANSMISSION

### Converter and/or Fluid Pump Seal Ring — Replace

#### REMOVE, DISCONNECT

1. Transmission.
2. Converter from transmission.
3. Seal ring from transmission — KM-J-7004 and KM-586.

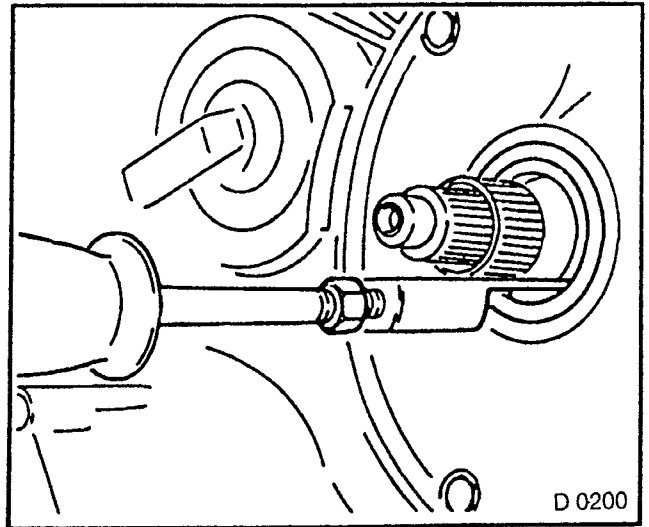


Fig. 268

#### INSTALL, CONNECT

1. Drive in new seal ring flush — KM-674.
2. Converter in transmission.
3. Transmission.

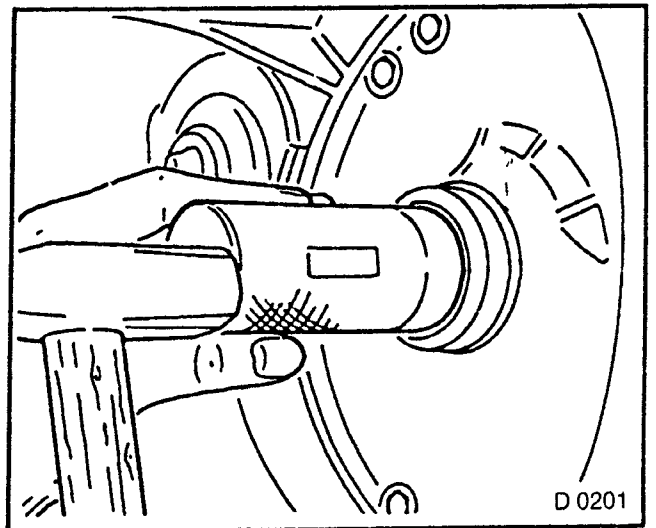


Fig. 269

### Housing Parts and/or Gasket — Replace

#### REMOVE, DISCONNECT

1. Transmission — drain transmission fluid.  
Drain bolt (1), on right housing underside.

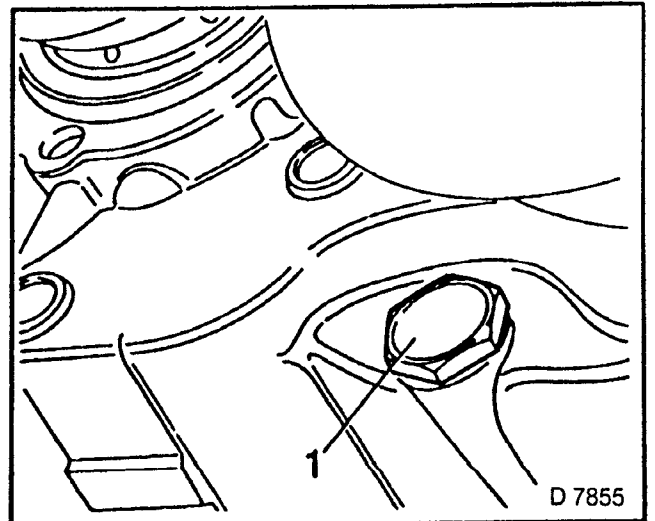


Fig. 270

**INSTALL, CONNECT**

1. KM-694 (1) on transmission.
2. Place assembly on Base KM-113-2 (2) and arrest horizontally.

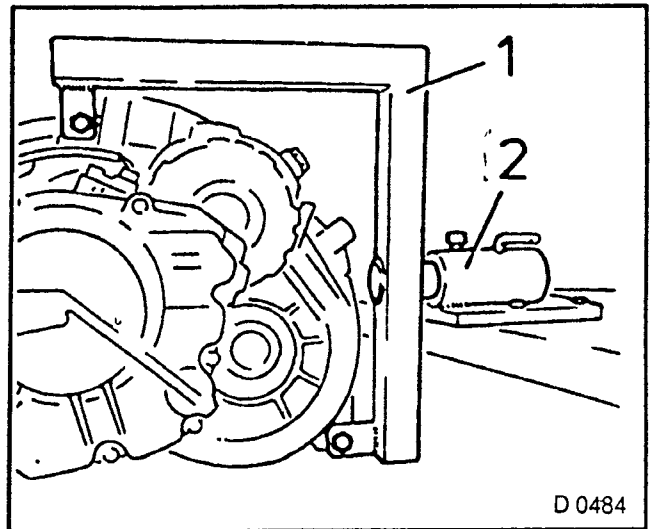


Fig. 271

**REMOVE, DISCONNECT**

1. Converter — fluid escapes.
2. When replacing main housing and/or auxiliary housing, but without disassembling assemblies — see page 135 "Transmission, Overhaul".
3. Fix transmission horizontally using KM-113-2 (auxiliary housing points upwards), since during separation of housing parts assemblies are freed and can fall out.

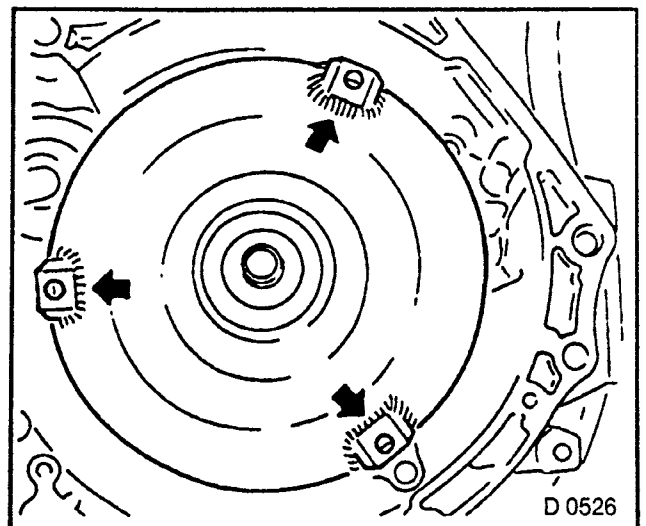


Fig. 272

4. Fifteen bolts of auxiliary housing from main housing (1).
5. Separate housing parts, if necessary use plastic hammer.
6. Fluid filter (3), fluid retaining plate from auxiliary housing three bolts, Fig. 274, Item (1).

**CLEAN**

1. Sealing surfaces of housing parts.
2. Fluid filter.
3. Three magnets behind fluid retaining plate.
4. Following this, blow parts dry.

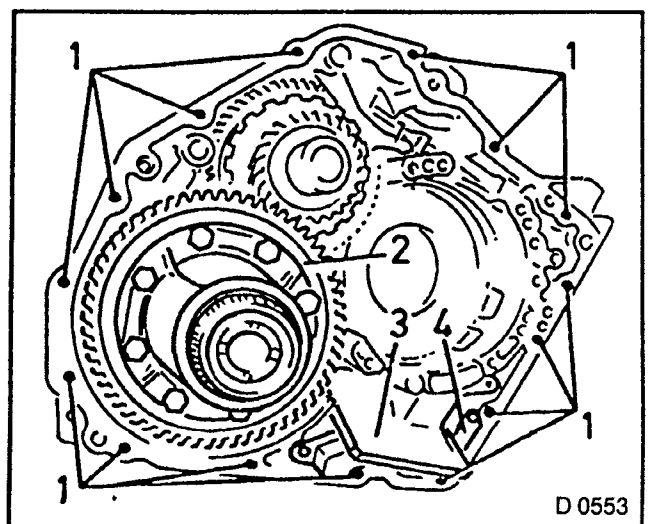


Fig. 273

**TIGHTEN (TORQUE)**

1. Fluid retaining plate to auxiliary housing (1) — 6 Nm.
2. Fluid filter to main housing — 6 Nm.

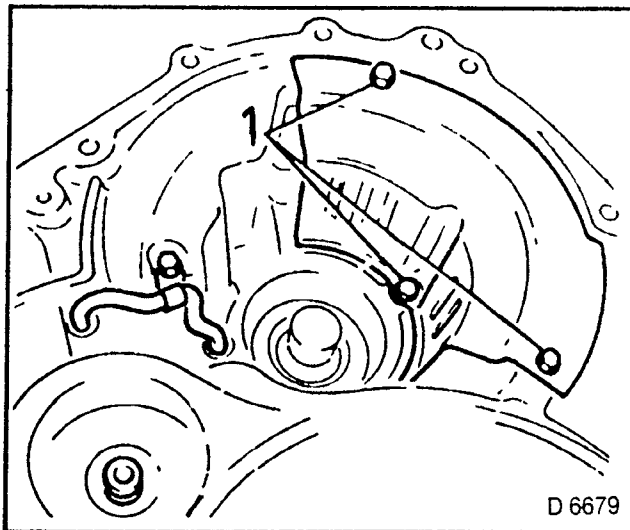


Fig 274

3. Auxiliary housing to main housing — 30 Nm (Fifteen bolts). Coat sealing surface with Sealing Compound (Loctite 242), not centering pin.

**INSTALL, CONNECT**

1. Converter — ensure it engages correctly in fluid pump shaft.
2. Transmission.
3. Fill with transmission fluid (B0400075) — filling quantity: see Technical Data, page 263.
4. Check for leaks.

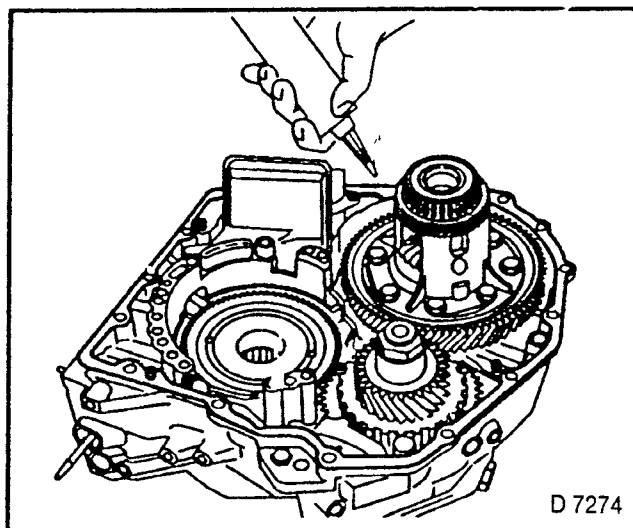


Fig. 275

**Transmission —  
Remove and Install****REMOVE, DISCONNECT**

1. Ground cable from battery.
2. Cable from selector actuation.
3. Retaining clamp from cable.
4. Cable from bracket.

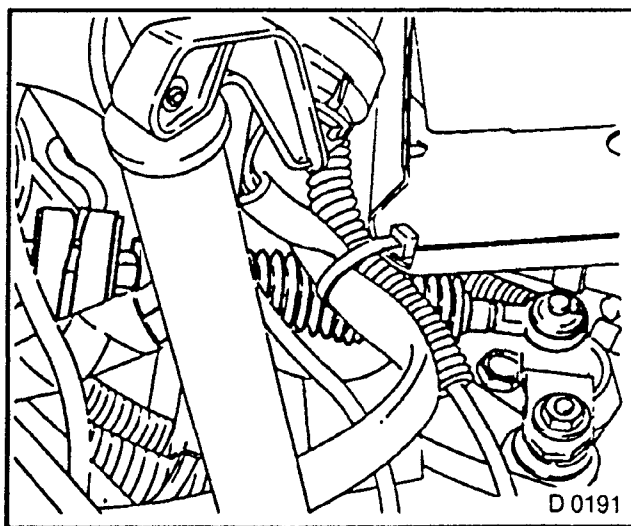


Fig 276



- 4 Vent hose from transmission — below battery bracket.
5. Disconnect transmission wiring harness plug.
6. Bracket for wiring harness from transmission.

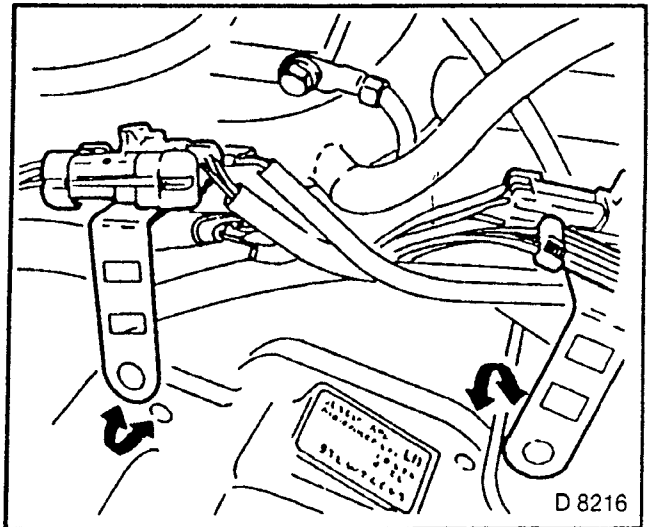


Fig. 277

### REMOVE, DISCONNECT

1. Three upper screws from transmission on engine
2. Oxygen sensor cable connection (behind coolant expansion tank).

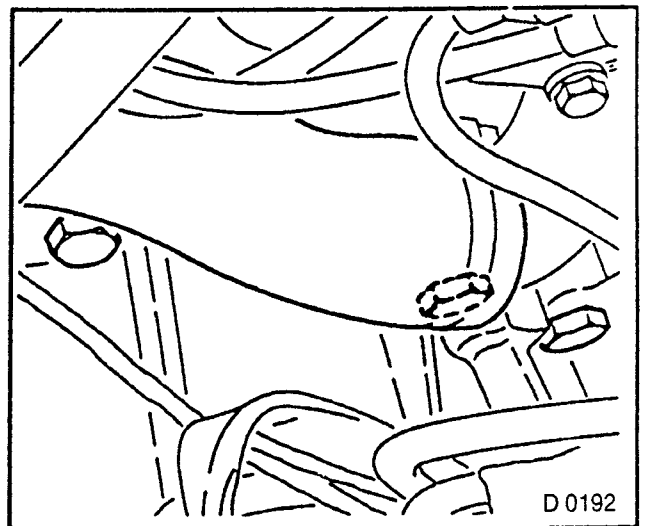


Fig. 278

3. Hold engine with KM-263-A and spring hook.
4. Fasten spring hooks to shackle behind distributor.

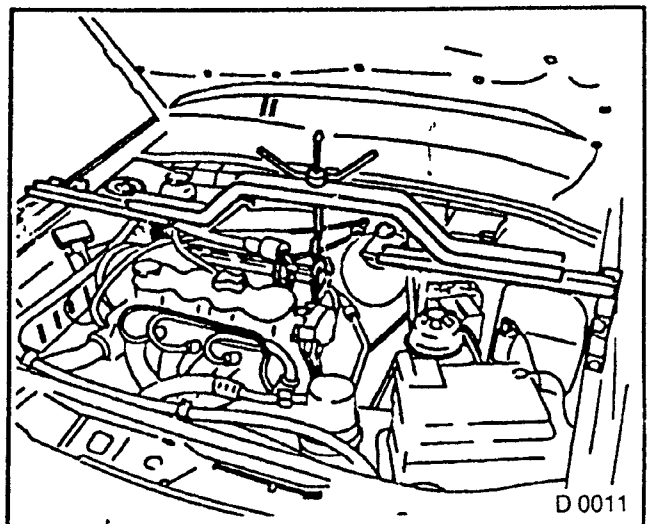


Fig 279

**REMOVE, DISCONNECT**

1. Front exhaust pipe.
2. Front axle body.
3. Speedometer cable (Fig. 280).

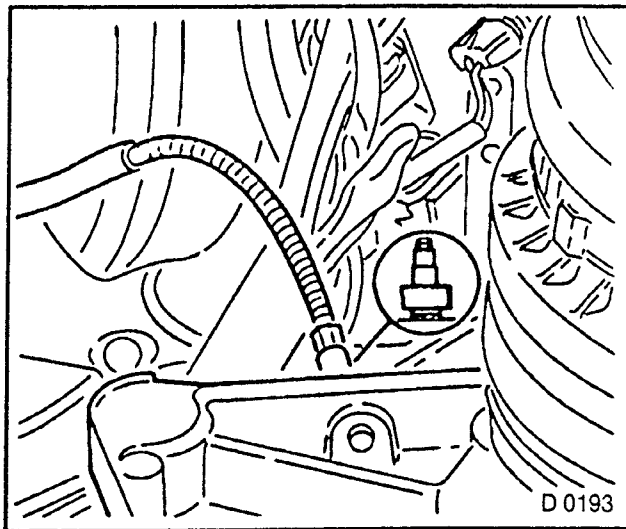


Fig. 280

4. Axle shafts from transmission.
  - Left KM-503-A (1)
  - Right KM-460-2-A
5. Chamfered side to transmission — fluid escapes.
6. Close off openings.
7. Secure axle shafts in position.

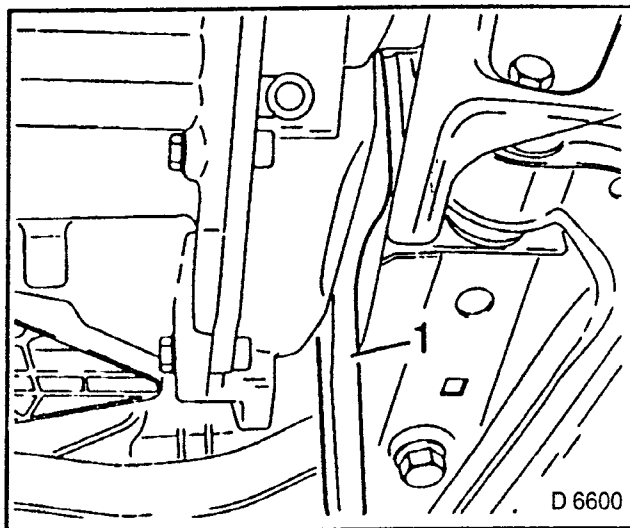


Fig. 281

**REMOVE, DISCONNECT**

1. Connecting hoses.
2. Transmission/fluid cooler
3. Loosen hose clamps on transmission.
4. Close openings — fluid escapes.

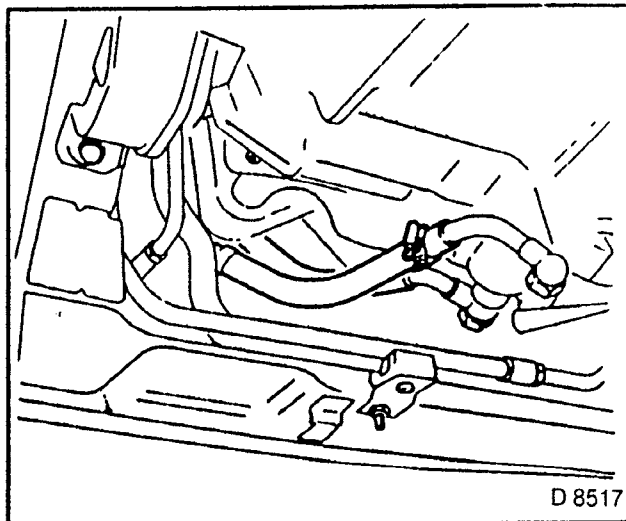


Fig. 282

5. Cover plate from transmission
6. Converter from drive disc — three bolts, counterhold drive disc.

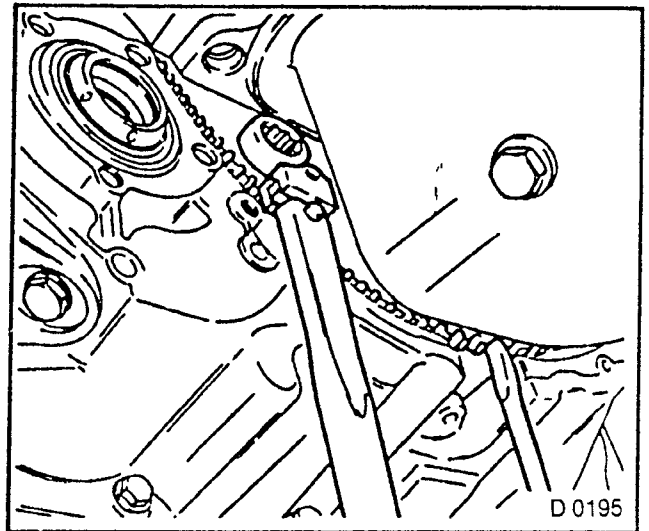


Fig 283

### REMOVE, DISCONNECT

1. Damper block from front frame side member
2. Bracket remains on transmission.
3. Lower engine — transmission housing upper edge aligns with front frame side member.

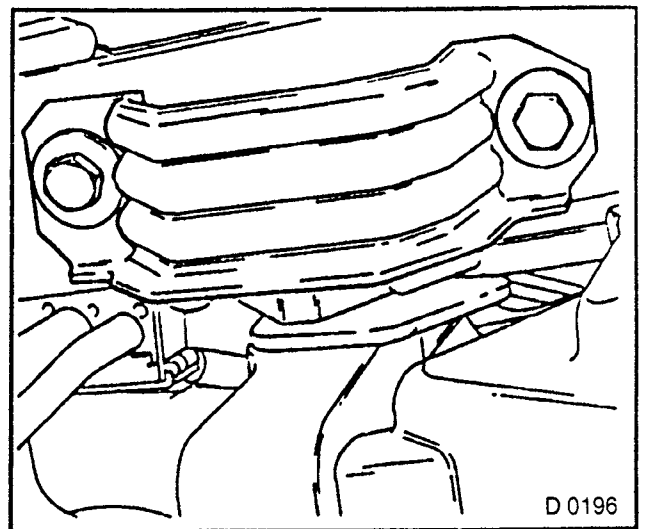


Fig 284

- 4 Three lower bolts (arrows) from transmission to engine. Hold transmission with hydraulic jack and lower.

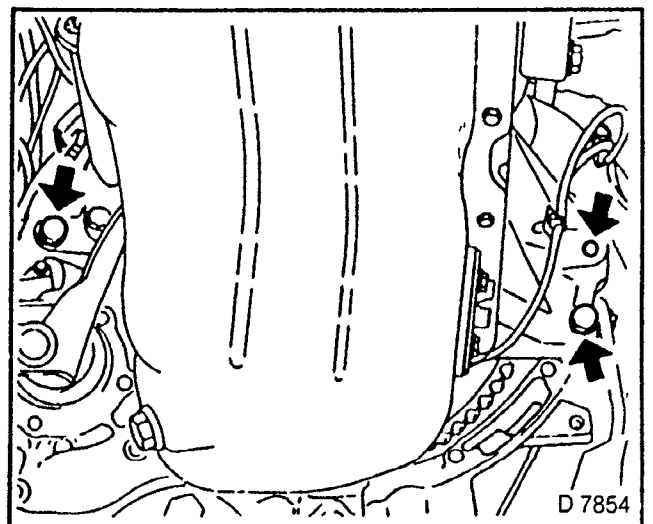


Fig. 285

**REMOVE, DISCONNECT**

1. Converter from transmission — fluid escapes.

**CLEAN**

1. Recut thread of converter (arrows), M 10 x 1.25.
2. Recut thread for damping block to left front frame side member; M 10 x 1.25
3. When replacing transmission: fluid cooler.

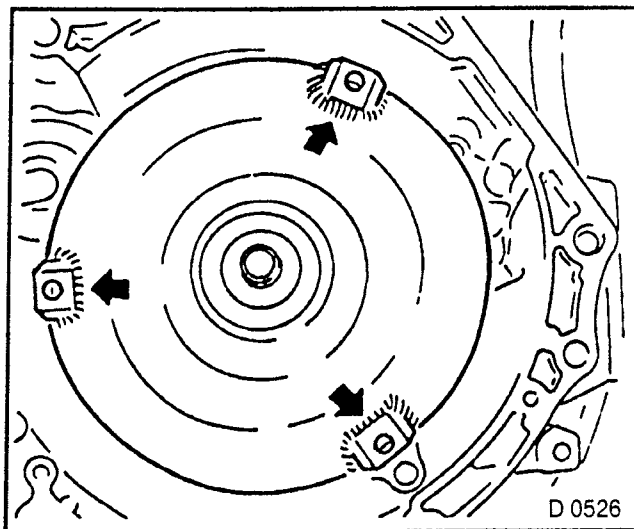


Fig. 286

**INSTALL, CONNECT**

1. Attach transmission to engine on hydraulic jack, one guide bushing

**TIGHTEN (TORQUE)**

1. Three lower bolts (arrows) for transmission to engine — 75 Nm.
2. Raise engine with KM-263-A

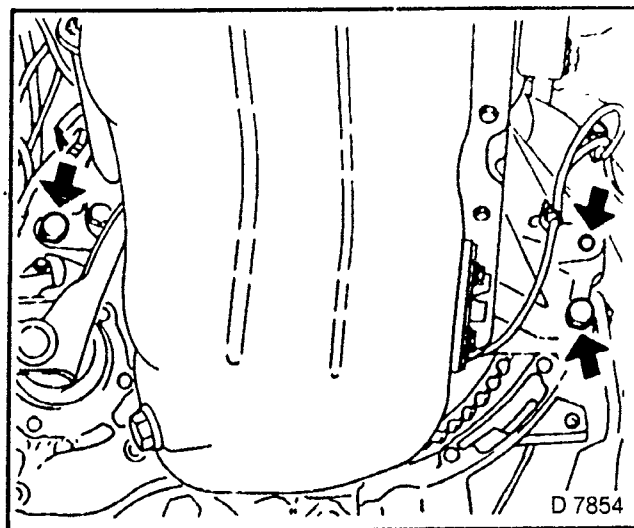


Fig 287

**TIGHTEN (TORQUE)**

1. Damper block to front left frame side member — 65 Nm.
2. New screws; align transmission with hydraulic jack.
3. Converter to drive disc — 50 Nm.
4. New screws, use torque wrench with flat ring cap, counterhold drive disc.
5. Cover plate to transmission — 7 Nm.

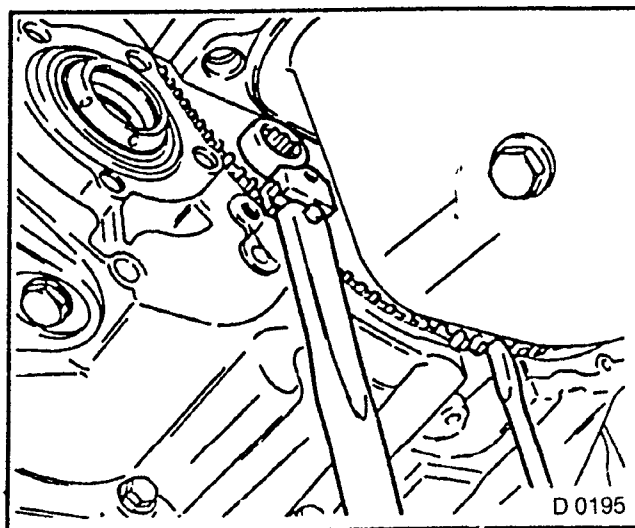


Fig. 288

**TIGHTEN (TORQUE)**

- 1 Connecting hoses, transmission/fluid cooler to transmission — 1.2 Nm.  
New hose clamps.  
Fluid escapes.

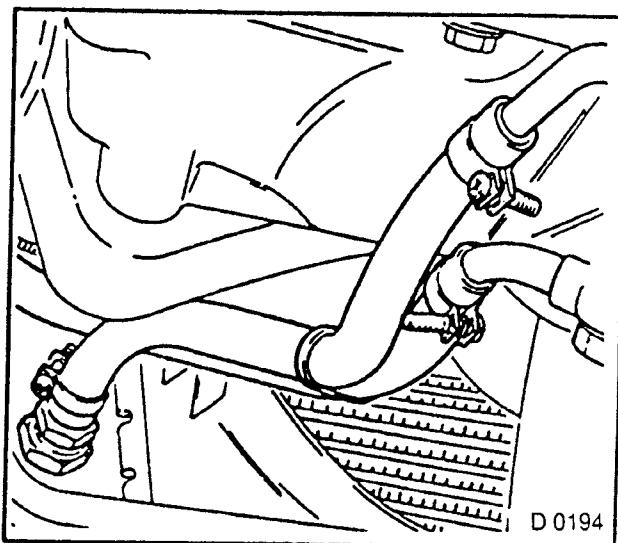


Fig. 289

**INSTALL, CONNECT**

1. Axle shafts.
2. New retaining ring (1).
3. Lubricate splines.
4. Automatic transmission fluid — Dexron IID.
5. Insert both axle shafts into transmission
6. Place square head drift at welding bead of friction welding seam (2) (not on sheet metal panelling).
7. Drive in axle shaft, retaining ring catches audibly.

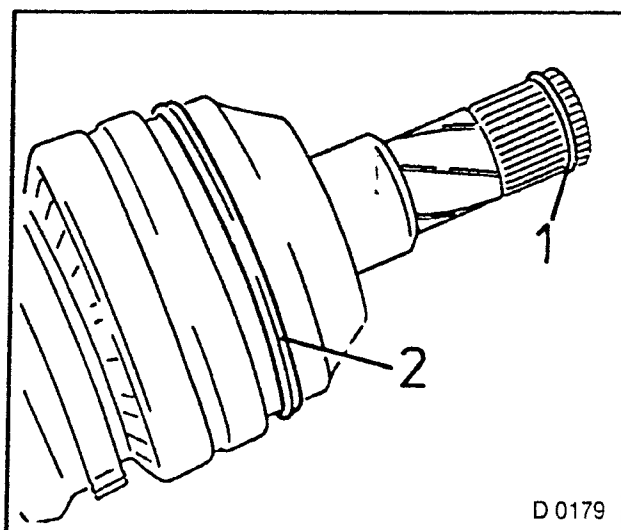


Fig. 290

**INSPECT**

1. Axle shaft position — pull on circumference of joint (**DO NOT** pull on shaft itself)

**INSTALL, CONNECT**

1. Speedometer cable.
2. Front axle body.
3. Front exhaust pipe. See Sections E and L.
4. Front wheels.
5. Lower vehicle, remove KM-263-A.

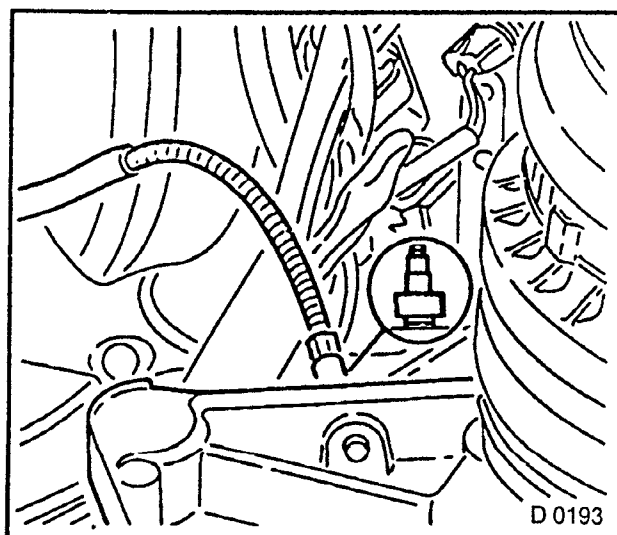


Fig. 291

**INSTALL, CONNECT**

1. Oxygen sensor cable connection (behind coolant expansion tank).
2. Ventilation pipe to transmission — under battery bracket.

**TIGHTEN (TORQUE)**

1. Three upper bolts for transmission to engine block — 75 Nm.
2. Cable to bracket — 6 Nm.

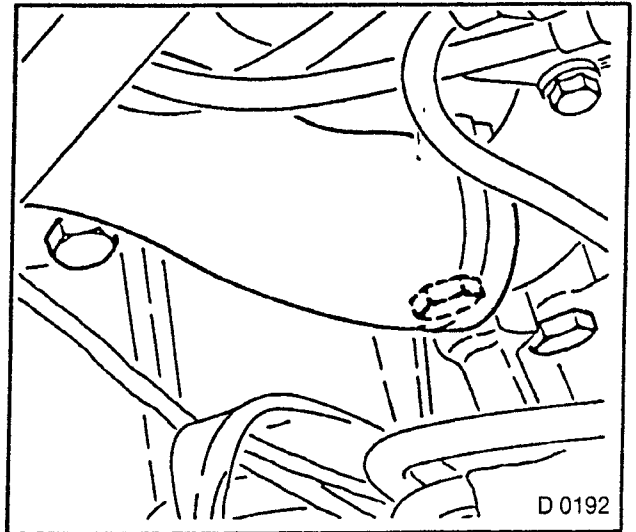


Fig. 292

**TIGHTEN (TORQUE)**

1. Two brackets for wiring harness to transmission, 30 Nm.
2. Connect transmission wiring harness plug.

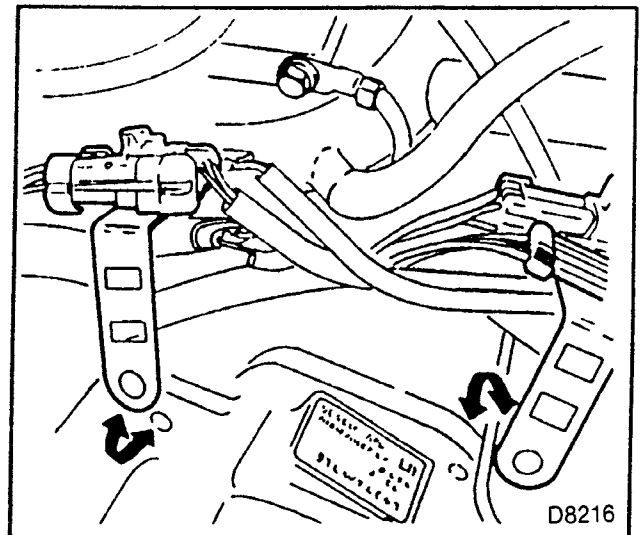


Fig 293

**INSTALL, CONNECT**

1. Cable to actuation lever.
2. Washer and retaining clamp to actuation lever.
3. Ground lead to battery.
4. Adjust selector actuation.
5. Fill up with transmission fluid.

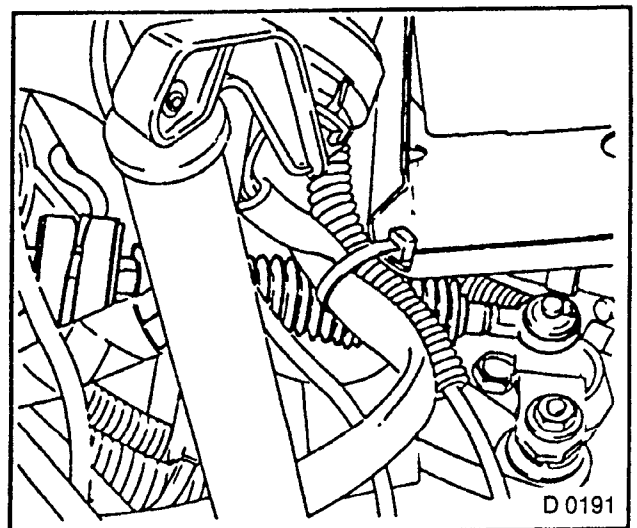
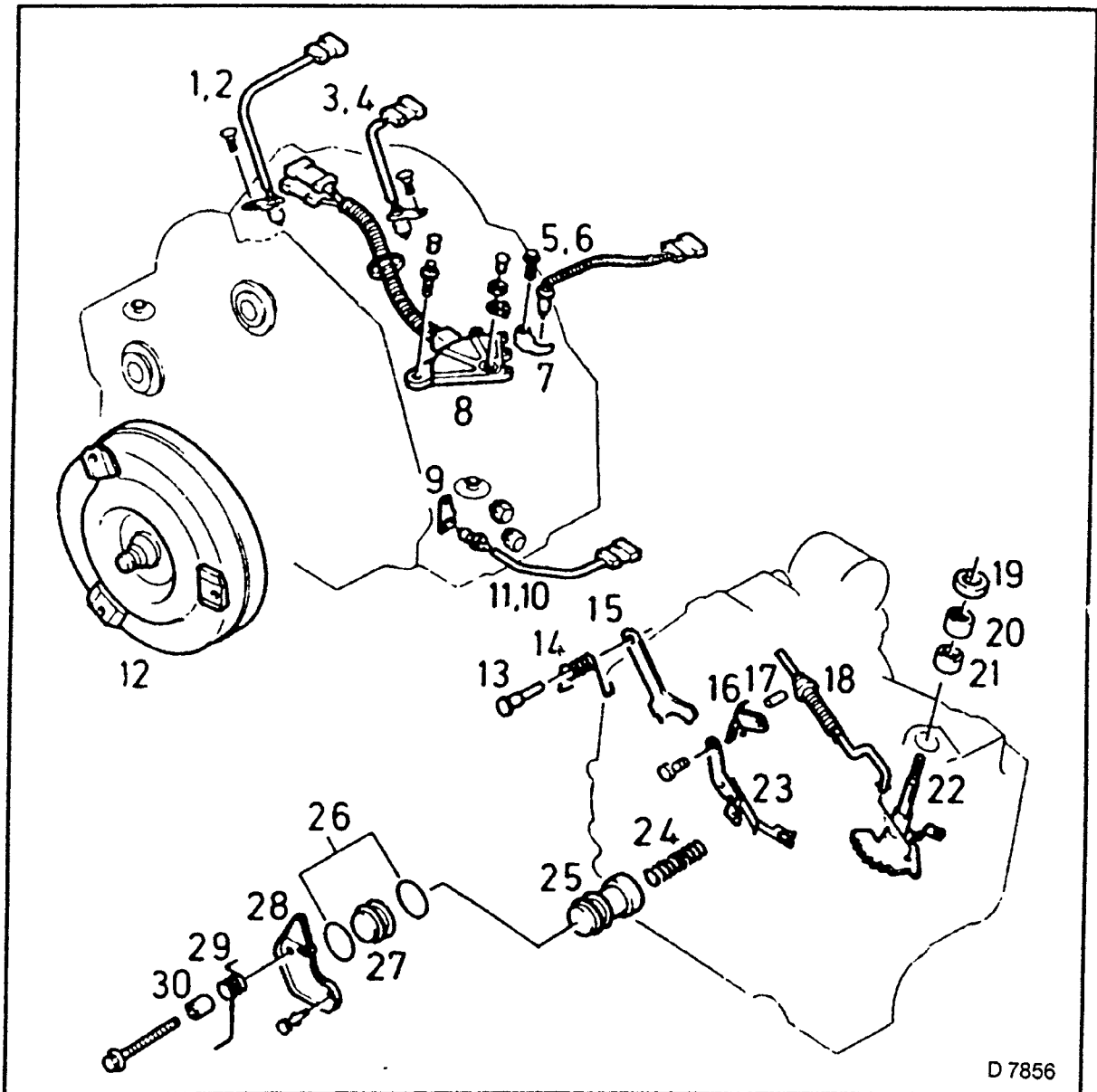


Fig. 294



D 7856

Fig. 295 — AF 20 — attaching parts.

- |  |                                     |
|--|-------------------------------------|
| 1 = Sensor, transmission output speed        | 17 = Pin for parking pawl           |
| 2 = Seal ring                                | 18 = Actuating rod for parking pawl |
| 3 = Sensor, transmission input speed         | 19 = Seal ring                      |
| 4 = Seal ring                                | 20*) = Outer needle bearing         |
| 5 = Solenoid valves wiring harness           | 21*) = Inner needle bearing         |
| 6 = Seal ring                                | 22 = Ratchet                        |
| 7 = Retaining plate                          | 23 = Detent spring                  |
| 8 = Selector lever position switch           | 24 = Compression spring             |
| 9 = Cover plate for fluid temperature sensor | 25 = Accumulator piston             |
| 10 = Seal ring                               | 26 = Seal rings                     |
| 11 = Fluid temperature sensor                | 27 = Accumulator cover              |
| 12 = Converter                               | 28 = Accumulator bracket            |
| 13 = Axle for parking pawl                   | 29 = Torsion spring no 2            |
| 14 = Torsion spring no. 1                    | 30 = Sleeve for spring guide        |
| 15 = Pawl for parking pawl                   |                                     |
| 16 = Cam plate                               |                                     |

\*) One part on newer transmissions

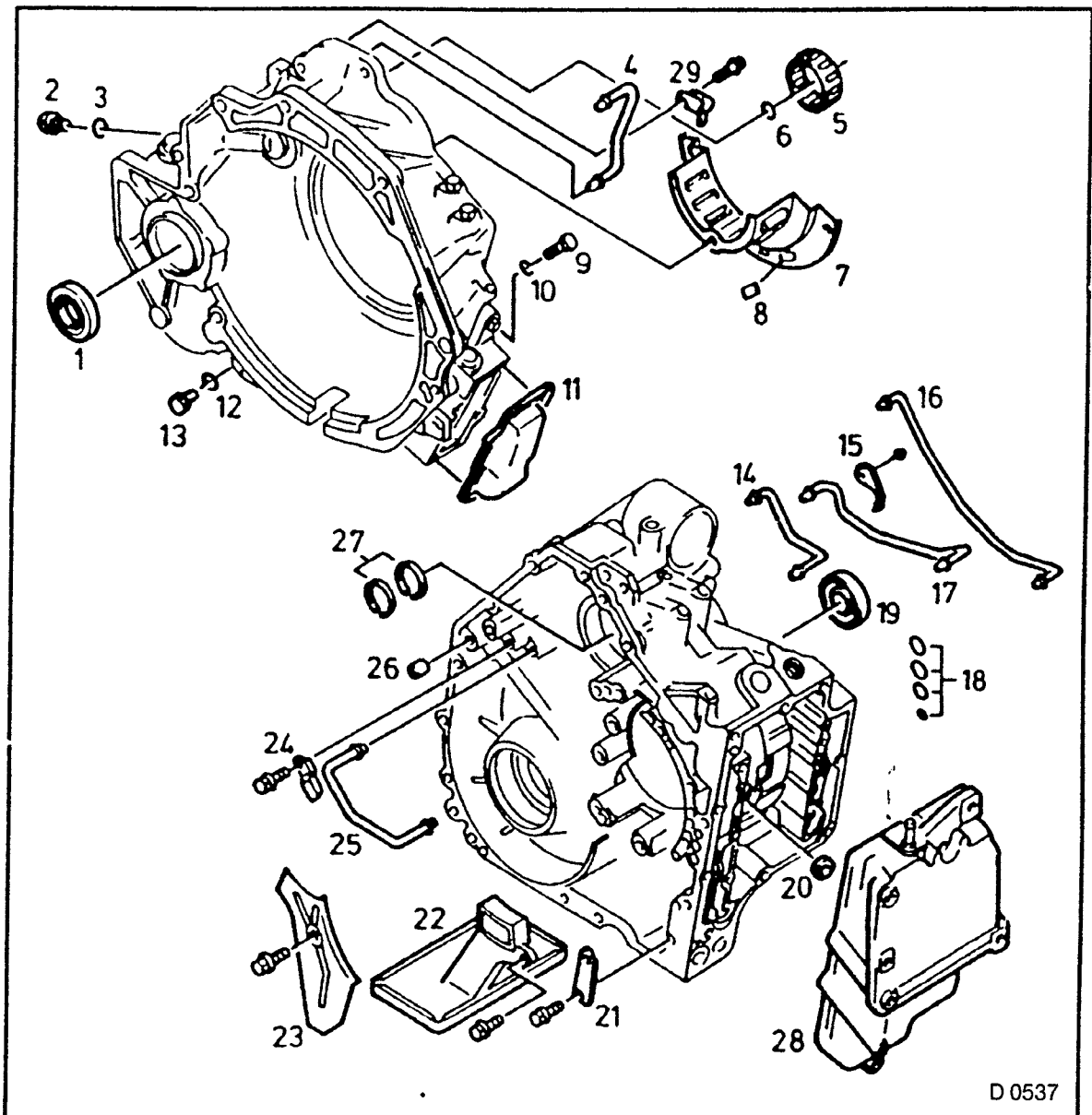


Fig. 296 — AF 20 — housing parts.

- |   |                                     |
|---|-------------------------------------|
| 1 = Plug — M 8                          | 16 = Main pressure pipe no 1        |
| 2 = Seal ring                           | 17 = Pipe clamp                     |
| 3 = Lubrication oil line                | 18 = Actuation pipe                 |
| 4 = Pipe clamp                          | 19 = Lubrication pipe               |
| 5 = Roller bearing                      | 20 = Axle shafts seal ring          |
| 6 = Seal ring                           | 21 = Gaskets for regulator          |
| 7 = Oil baffle plate, auxiliary housing | 22 = Gaskets for actuation (x 2)    |
| 8 = Magnet (x 3)                        | 23 = Side cover                     |
| 9 = Plug — M 8                          | 24 = Main housing plate             |
| 10 = Seal ring                          | 25 = Oil baffle plate, main housing |
| 11 = Auxiliary housing cover            | 26 = Oil screen                     |
| 12 = Seal ring                          | 27 = Main pressure pipe no. 2       |
| 13 = Drain bolt                         | 28 = Pipe clamp                     |
| 14 = Axle shaft seal ring               | 29 = Seal ring                      |
| 15 = Hooked seal rings                  |                                     |



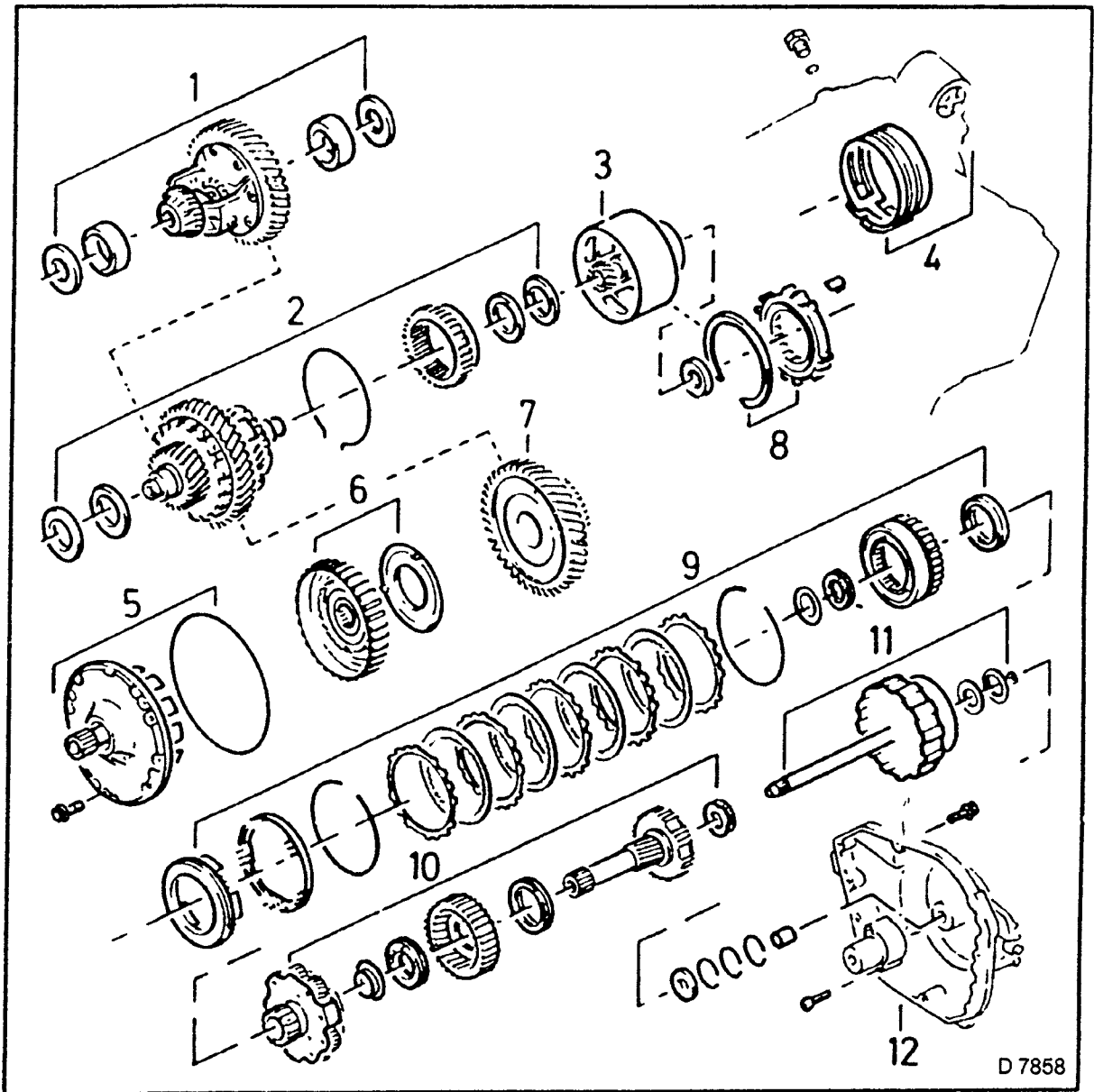


Fig. 297 — AF 20 — assemblies.

- 1 = Differential
- 2 = Planetary gear set P2
- 3 = Multi-plate clutch C3
- 4 = Brake band B4
- 5 = Fluid pump
- 6 = Freewheel F1
- 7 = Intermediate drive gear
- 8 = Freewheel F3
- 9 = Multi-disc brake B3 and freewheel F2
- 10 = Planetary gear set P1
- 11 = Multi-plate clutch C1 and C2-drive shaft assembly
- 12 = Rear cover

## TRANSMISSION, OVERHAUL

### Assemblies — Remove from Transmission

#### TRANSMISSION REMOVED:

Drain transmission fluid.

Drain bolt (1), on right housing underside.

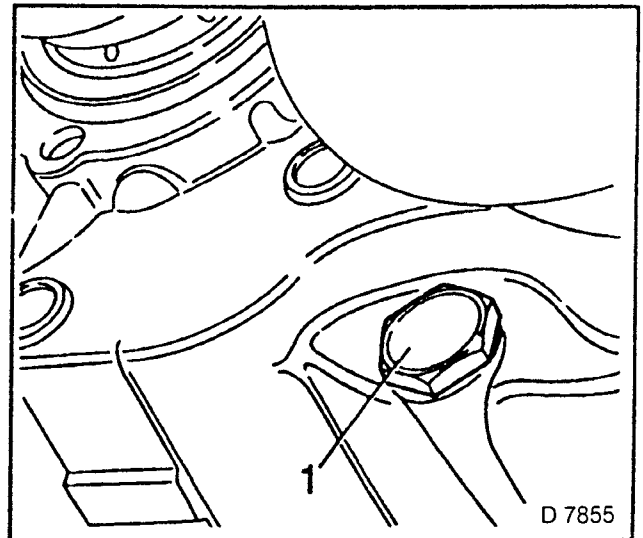


Fig 298

### INSTALL, CONNECT

1. Holder KM-694 (1) on transmission.
2. Place assembly on Base KM-113-2 (2).

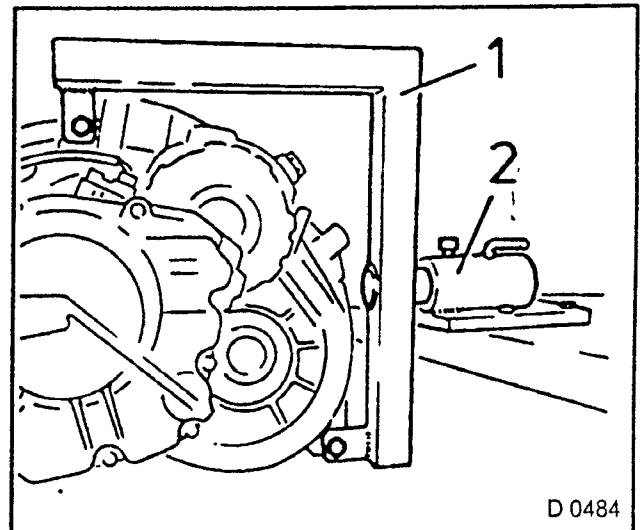


Fig 299

### Attaching Parts from Transmission — Remove

#### REMOVE, DISCONNECT

1. Converter — fluid escapes.
2. Fluid filler tube and selector lever position switch.
3. Actuation lever (3) from selector lever shaft (2).
4. Retaining plate (1, with screwdriver).
5. Pull switch upwards from selector lever shaft (2).

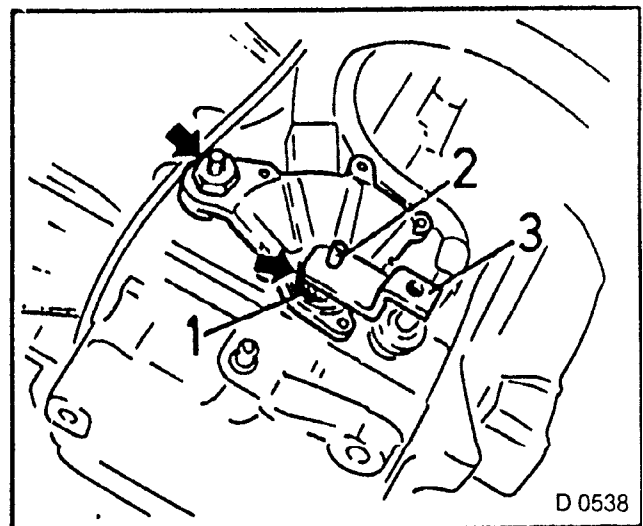


Fig. 300

6. Transmission input speed sensor (1).
7. Transmission output speed sensor (2)
8. Speedometer helical gear (driven).
9. Replace all seal rings.

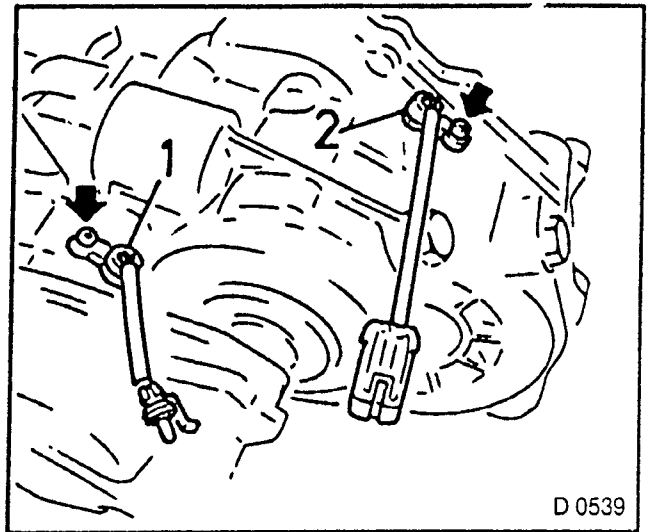


Fig 301

### REMOVE, DISCONNECT

1. Seven plugs M 8 (1).
2. One plug M 14 (2).
3. One plug M 18 Torx (3).
4. Two plugs M 20 (4).
5. Renew seal rings of plugs.

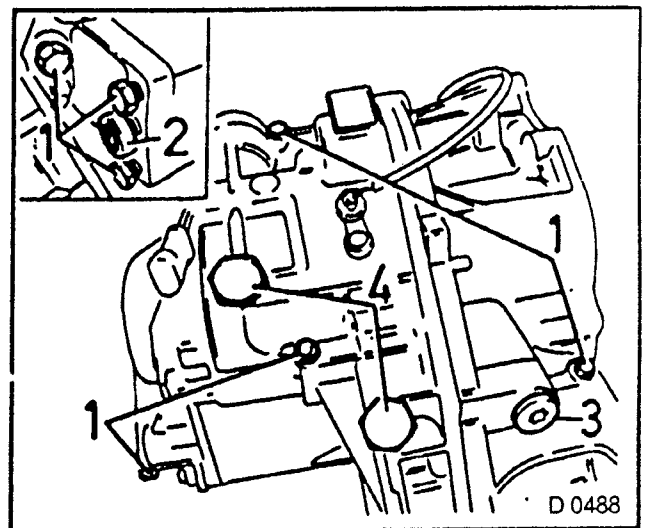


Fig 302

6. Cover plate for fluid temperature sensor (arrows).
7. Fluid temperature sensor (1).
8. Auxiliary housing cover (2).

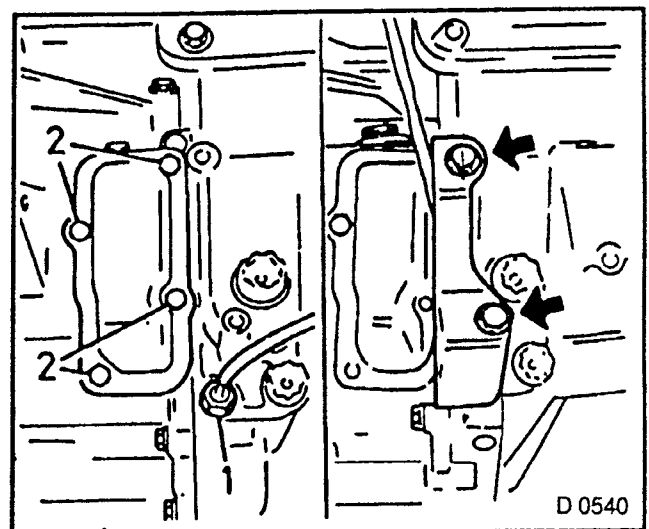


Fig 303

**REMOVE, DISCONNECT**

- 1 Side cover (seven bolts, arrows).

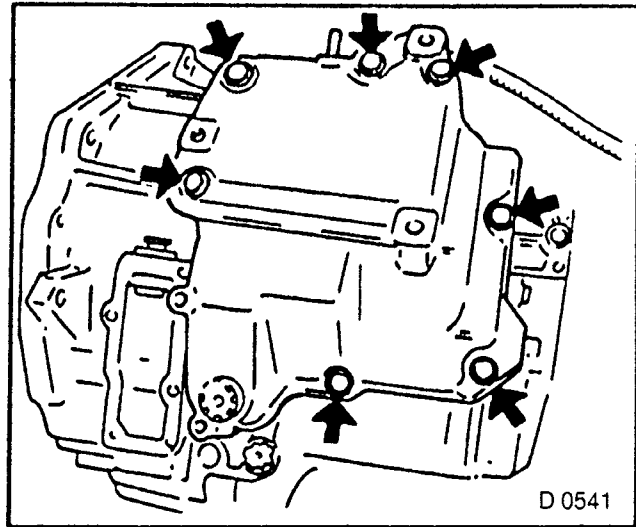


Fig. 304

2. Four wiring harness plugs (1) for solenoid valves of fluid pressure regulator.
3. Remove wiring harness from cable retainers.
4. Valve body — two bolts for intake cover (2).
5. Seven bolts for valve body from transmission (3).

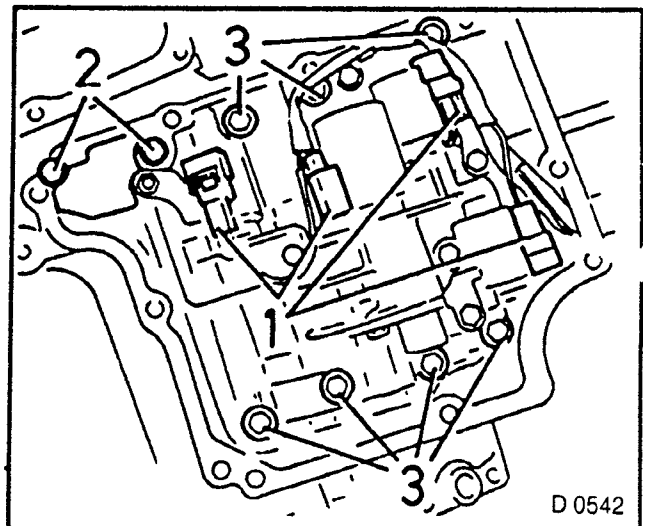


Fig. 305

**REMOVE, DISCONNECT**

1. Connecting rod (1) from ratchet (2). Hold valve body, if necessary lift locking spring (3), so that ratchet (2) can be turned.
2. Ratchet (2) — guide sideways out of main housing.
3. Lever out seal ring with screwdriver.
4. Solenoid valves wiring harness.
5. Loosen retaining plate (4). Renew rubber O-seal ring.
6. Two gaskets for actuation (5).

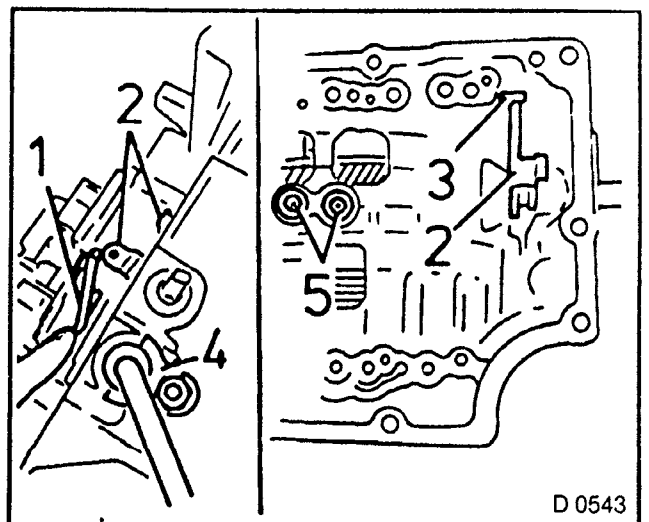


Fig. 306

7. Fluid pump from transmission — eight bolts, Remover KM-702 in two threaded bores of fluid pump.

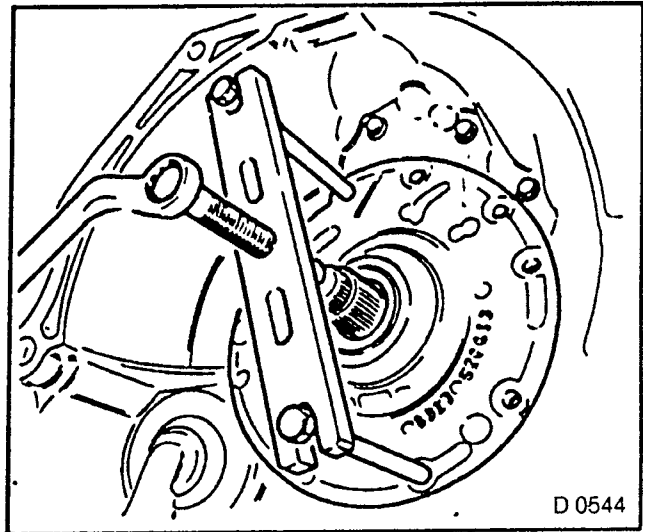


Fig 307

**REMOVE, DISCONNECT**

1. Freewheel F1 from drive shaft.

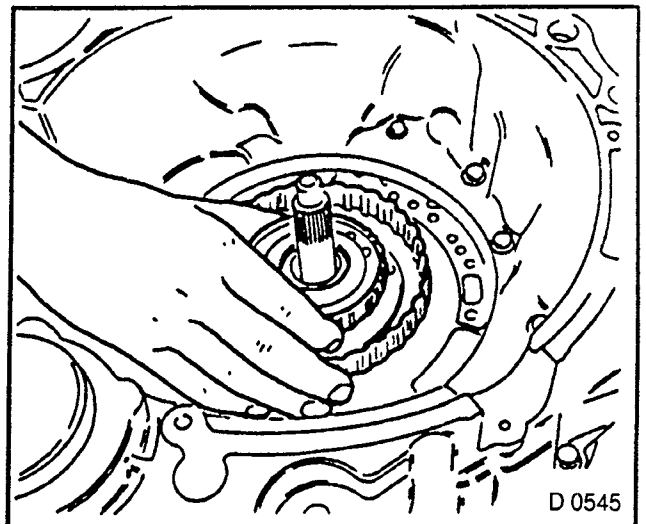


Fig 308

2. Rear housing cover — Nine bolts (arrows, left).
3. Four gaskets — behind housing cover (arrows).

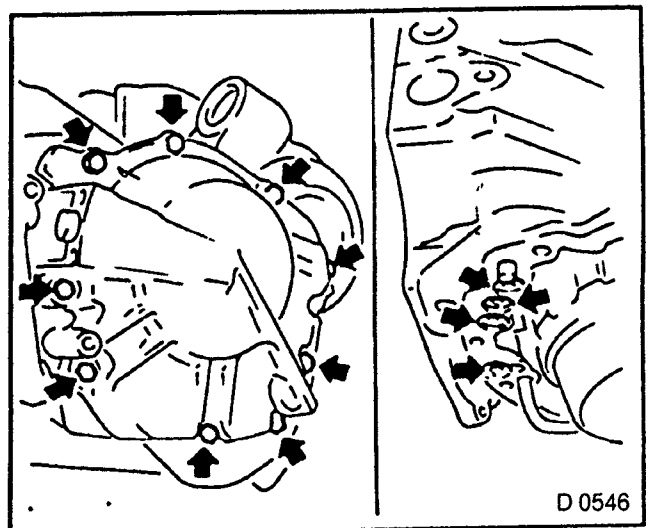


Fig 309

## REMOVE, DISCONNECT

1. Pipes for actuation (3) — One pipe clamp, lever out pipe ends.  
If resistant; remove pipe lines with Slide Hammer KM-J-7004 and Hook KM-586.

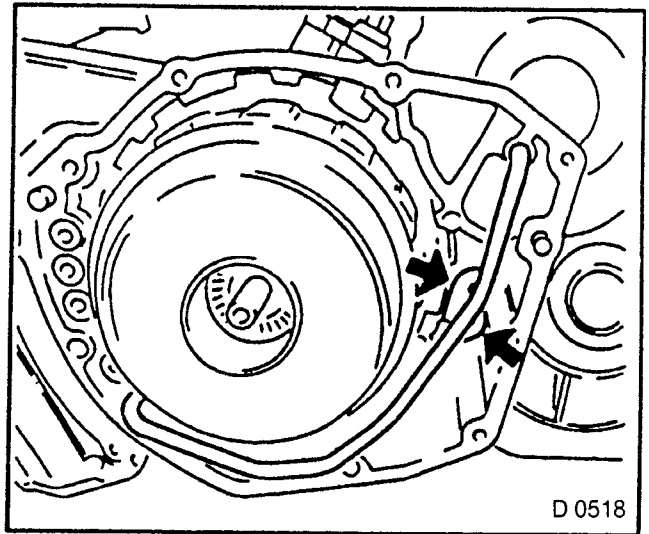


Fig 310

2. Drive shaft assembly (remove in direction of arrow).  
**NOTE CONDITION AND INSTALLATION POSITION OF THRUST BEARING AND RACE ASSEMBLY.**

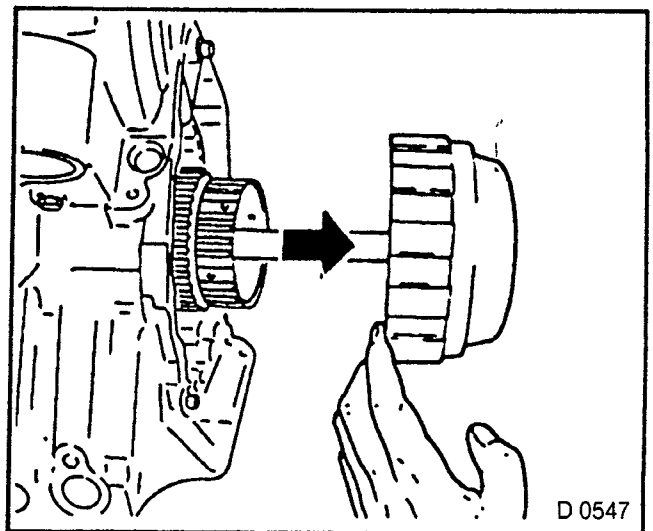


Fig 311

## REMOVE, DISCONNECT

1. Planetary gear set P1 with sun gear from transmission.  
**NOTE CONDITION AND INSTALLATION POSITION OF THRUST BEARING AND RACE ASSEMBLY.**

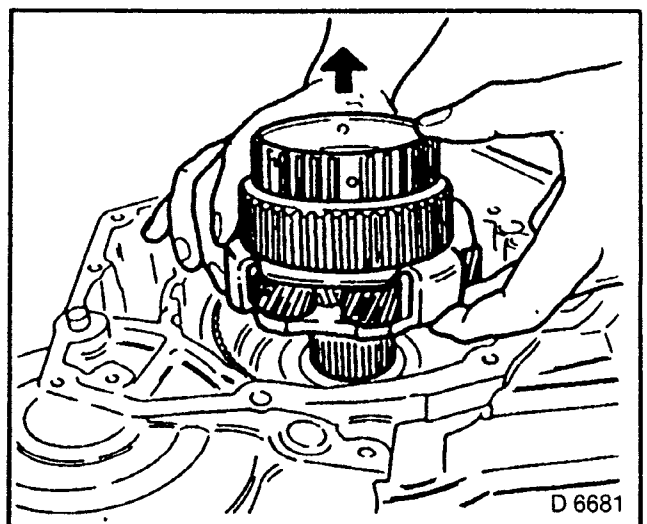


Fig 312

2. Front internal gear and freewheel no. 2 — retaining ring.
3. Assembly with steel plates.
4. Remove lining plates and flange of multi-disc brake B3.

### INSPECT

1. Steel and lining plates for damage and wear.  
Before installing, lay new lining plates for at least two hours in transmission fluid.

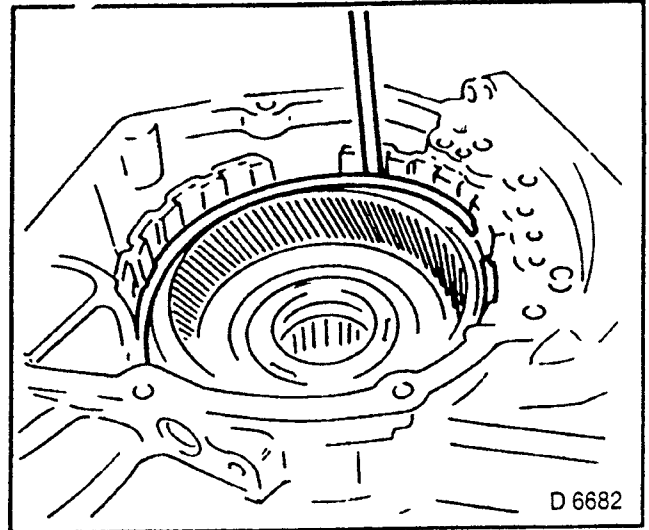


Fig. 313

### REMOVE, DISCONNECT

1. Return spring assembly (1).
2. Retaining ring.

### MEASURE

1. Free length of return springs, including spring cup — Measurement value: 20 mm.

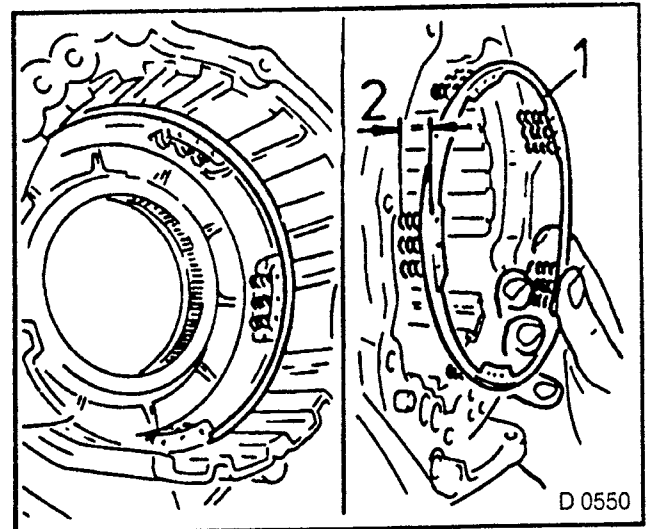


Fig. 314

### REMOVE, DISCONNECT

1. Piston for multi-disc brake B3.
2. Blow in low pressure air (arrow); if necessary, assist with pliers.
3. Renew inner and outer seal rings on pistons (arrows).

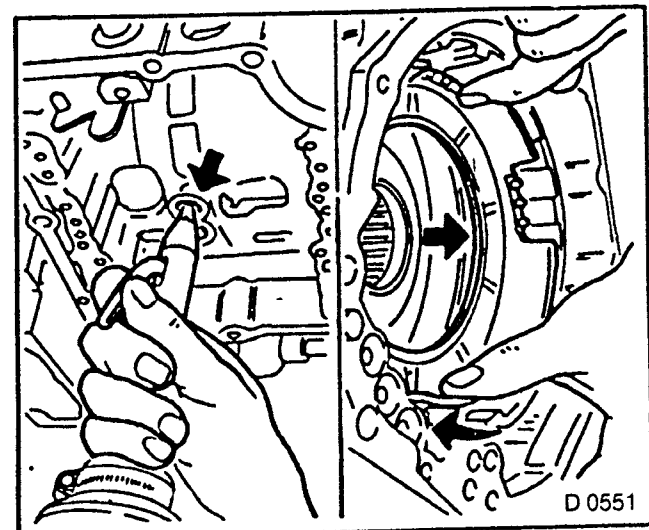


Fig. 315

**REMOVE, DISCONNECT**

1. Intermediate drive gear.
2. Retaining ring Remove component towards reverse (arrow)

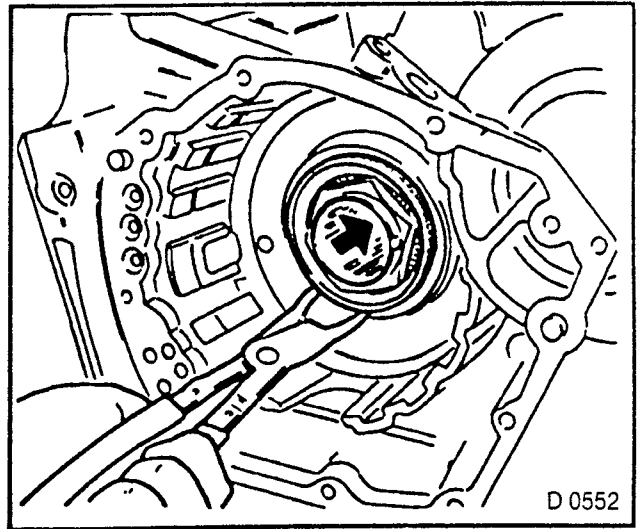


Fig. 316

- 3 Lock transmission horizontally  
Fifteen bolts (1) of auxiliary housing — if necessary separate housing parts with plastic hammer
- 4 Differential (2).
5. Fluid filter.
6. One bolt (3).
7. Main housing plate.
- 8 Two bolts (4, located next to fluid filter).

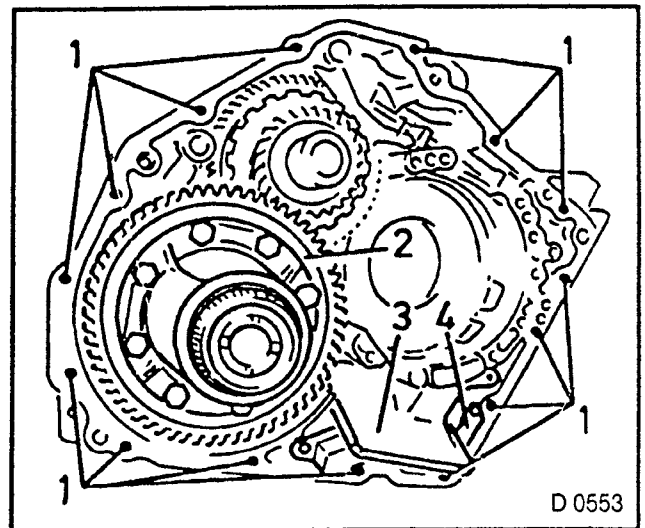


Fig 317

**REMOVE, DISCONNECT**

1. Seal ring from main housing (arrow).

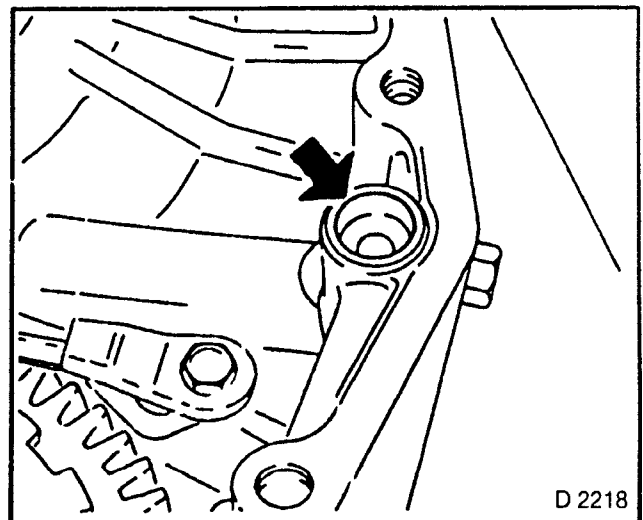


Fig 318



2. Both axle shaft seal rings from main or auxiliary housing.
3. Drive from inside outwards using suitable drift.

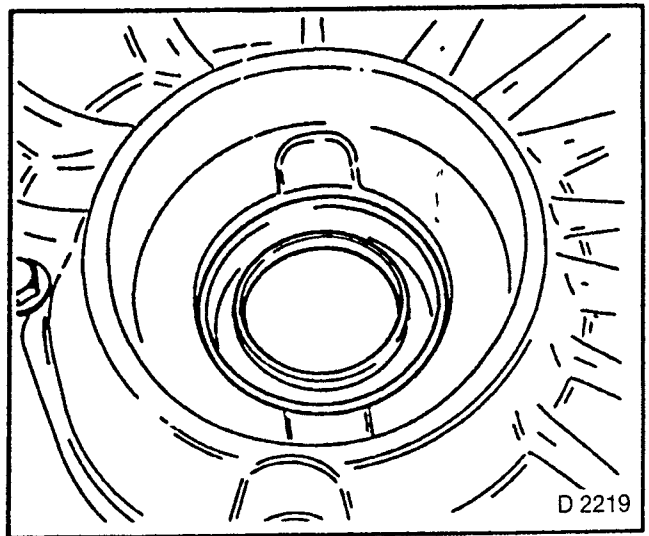


Fig. 319

## DISASSEMBLE

1. Auxiliary housing.
2. Roller bearing from housing — KM-J-26941, KM-313, KM-483. If difficult to move, heat transmission housing with hot air blower to approximately 80°C/176°F (thermocolour pencils, or use suitable temperature gauge).

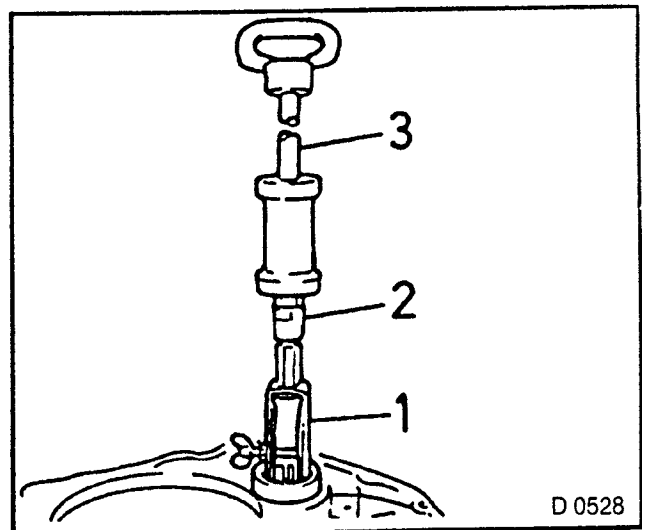


Fig. 320

3. Fluid line — loosen pipe clamp (1), lever out line using screwdriver.
4. Fluid retaining plate — Three bolts (2), Three magnets (on underside of fluid retaining plate).
5. Hook seal ring from pin in housing (3).
6. Ring ends are L-shaped. Press one ring end in groove, hook out the other. With new transmissions, as cut seal ring without hooks.

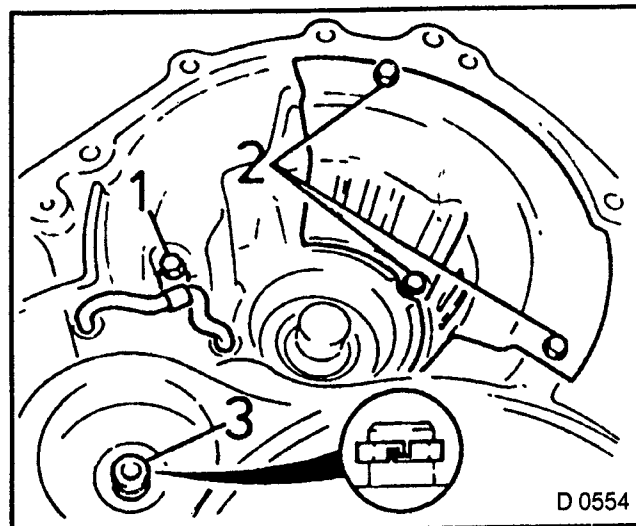


Fig. 321

**REMOVE, DISCONNECT**

1. Fluid retaining plate (1)
2. Main pressure pipe no. 2.
3. Loosen pipe clamp.
4. Lever out line using screwdriver (2).

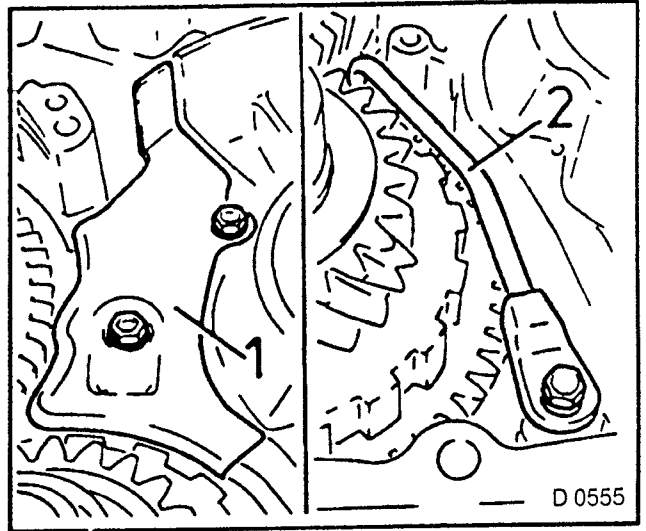


Fig 322

5. Parking pawl assembly
6. Detent spring — two bolts (1), guide rear spring end over detents of toothed segment
7. Actuation rod for parking pawl (2) from toothed segment — align recesses in toothed segment with lugs on rod (2) by turning.
8. Cam plate (3), axle for parking pawl and spring no. 1 (4).
9. Remove upwards.
10. Claw for parking pawl (5).
11. Pin for parking pawl — under cam plate (3)

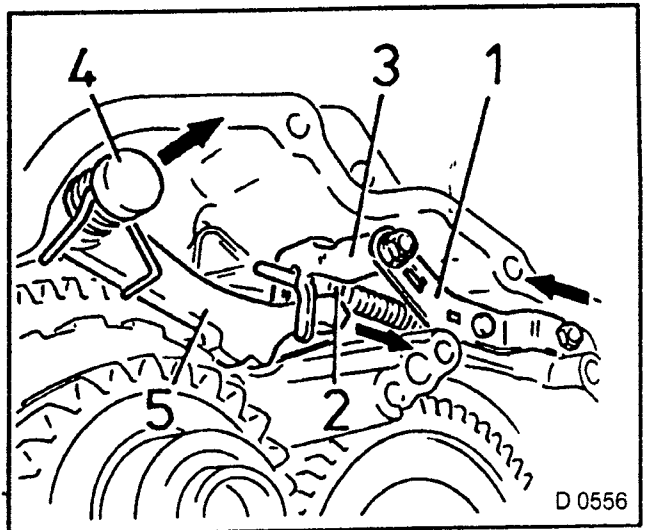


Fig 323

**REMOVE, DISCONNECT**

1. Accumulator cover for reduction brake. One Torx bolt (1), One bolt (2) with torsion spring no. 2 (3). Cover (5), Accumulator piston (6), Spring (4), Blow in low pressure air (arrow).
2. Renew rubber O-seal rings on cover (5) and piston (6).

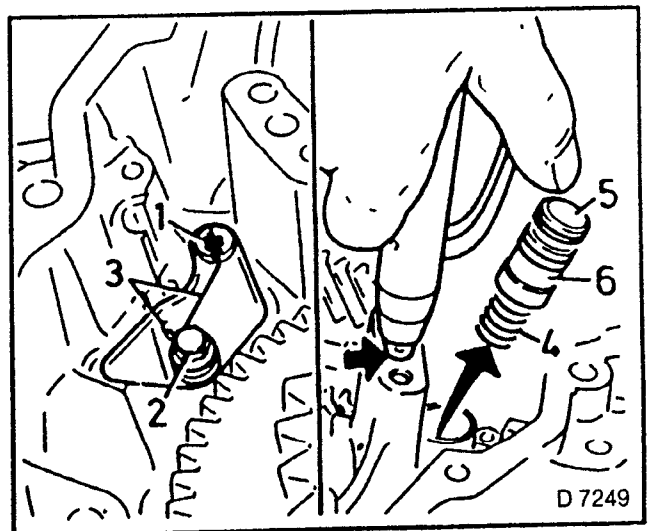


Fig. 324

3. Planetary gear set P2 (1) — note condition and installation position of thrust bearing and race assembly (2 — located in internal gear).

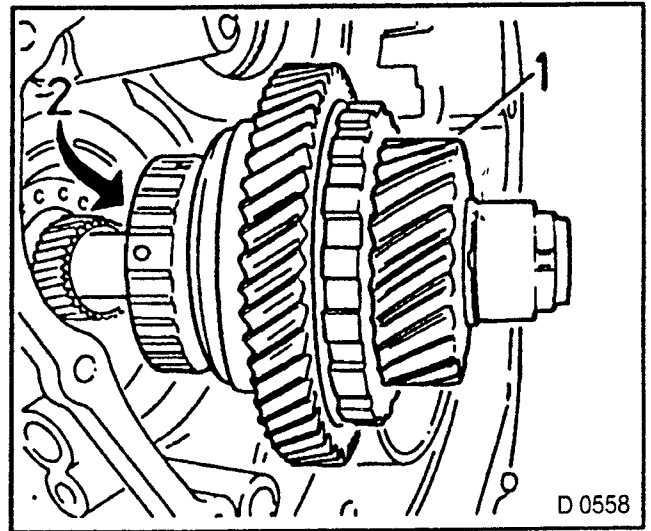


Fig. 325

### REMOVE, DISCONNECT

1. Reduction clutch (1).
2. Turn counter-clockwise and lift.
3. Thrust bearing (2),  
Brake band B4 (3) — unscrew anchor bolt,  
(4 protrudes from outside through housing).
4. Renew rubber O-seal ring.

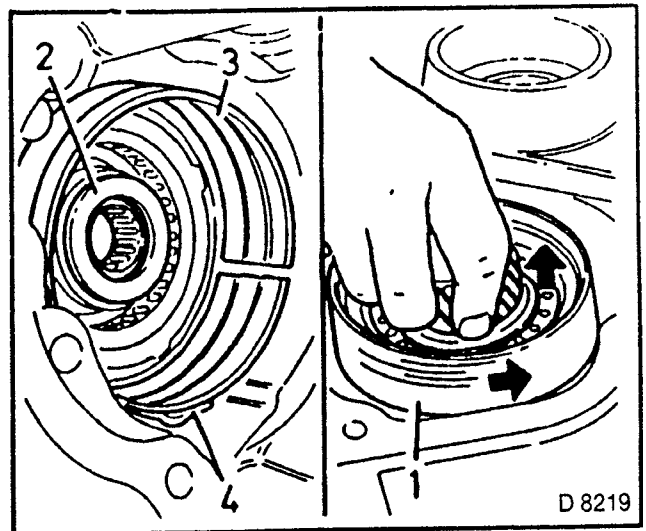


Fig. 326

5. Freewheel F3 (2) — mark top side.
6. Retaining ring (1).

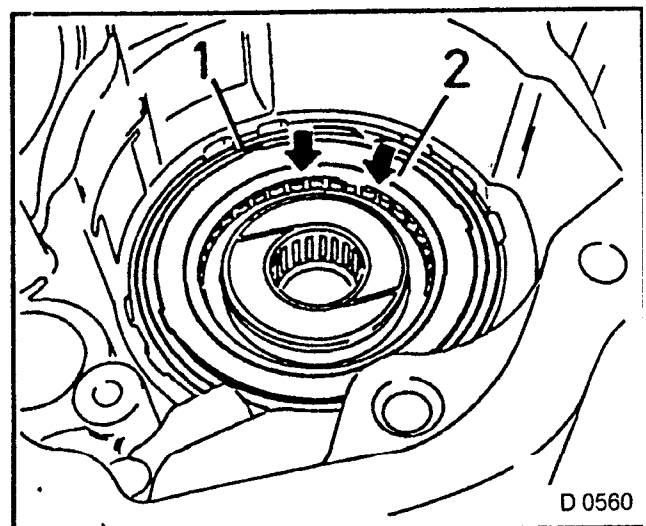


Fig. 327

**REMOVE, DISCONNECT**

1. Needle bearing for reduction clutch.
2. Pull out from main housing using KM-556-1 (1) and KM-556-2 (2). If necessary (arms of KM-556-1 too short), lay KM-502-A underneath.

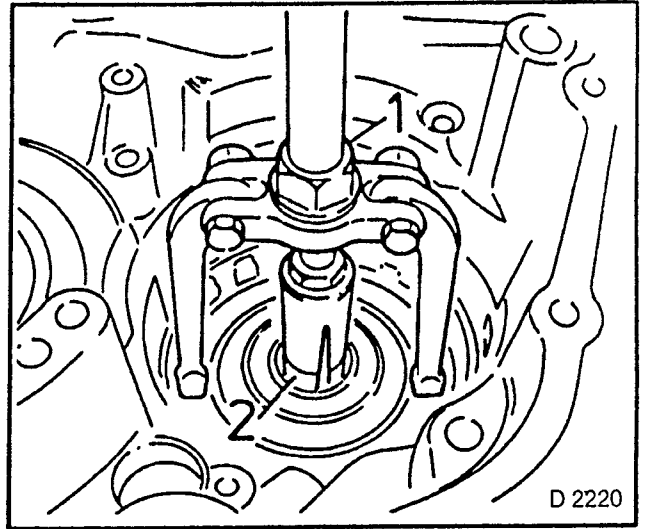


Fig 328

- 3 Seal ring for shaft of toothed segment from main housing.
  - 4 Needle bearings for shaft of toothed segment (two pieces).
  - 5 Drive both bearings from outside inwards using suitable drift.
- Single — part version in new transmissions.  
When replacing bearings on older transmissions, also use the single-part version.

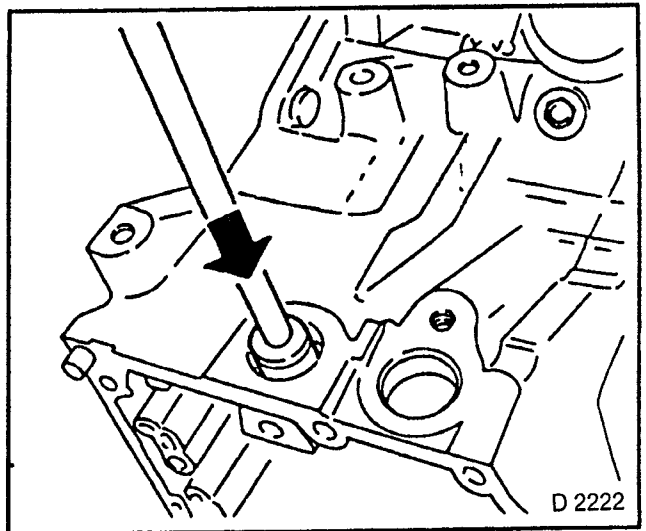


Fig. 329

**REMOVE, DISCONNECT**

1. Two hook seal rings from pin in housing — ring ends are L-shaped.
2. Press one ring end into groove, hook out the other.

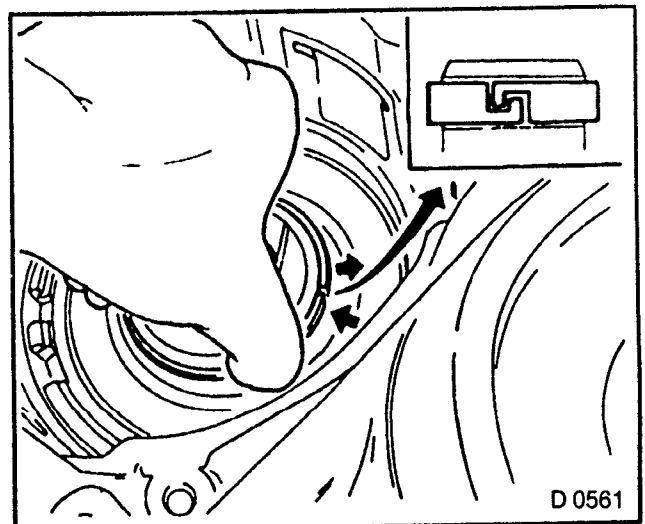


Fig. 330

3. Piston for reduction brake.

### CAUTION

Varying tolerances require special caution:  
Cover is spring-tensioned, secure against  
springing out  
Retaining ring with retaining ring pliers

### REMOVE, DISCONNECT

1. Retaining ring.
  2. Cover (if difficult, assist using pliers).
  3. Piston (1),  
Pressure spring (2),  
Damping spring (3).
- If difficult:  
Blow in low pressured air at inner side of  
housing (arrow).
4. Renew seal rings (4) at cover and  
piston (1).

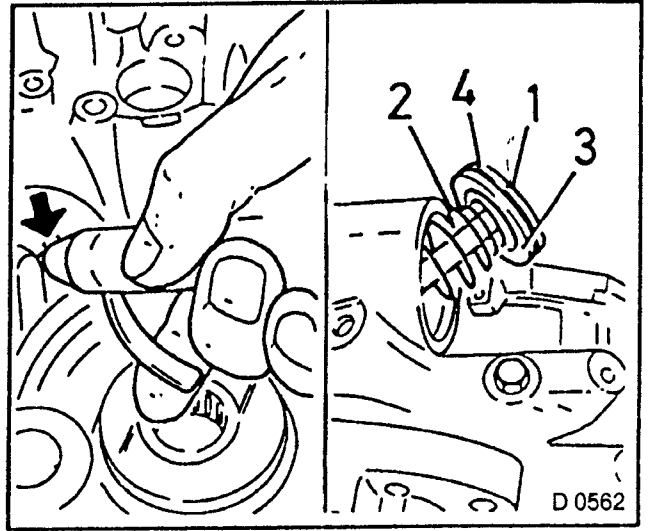
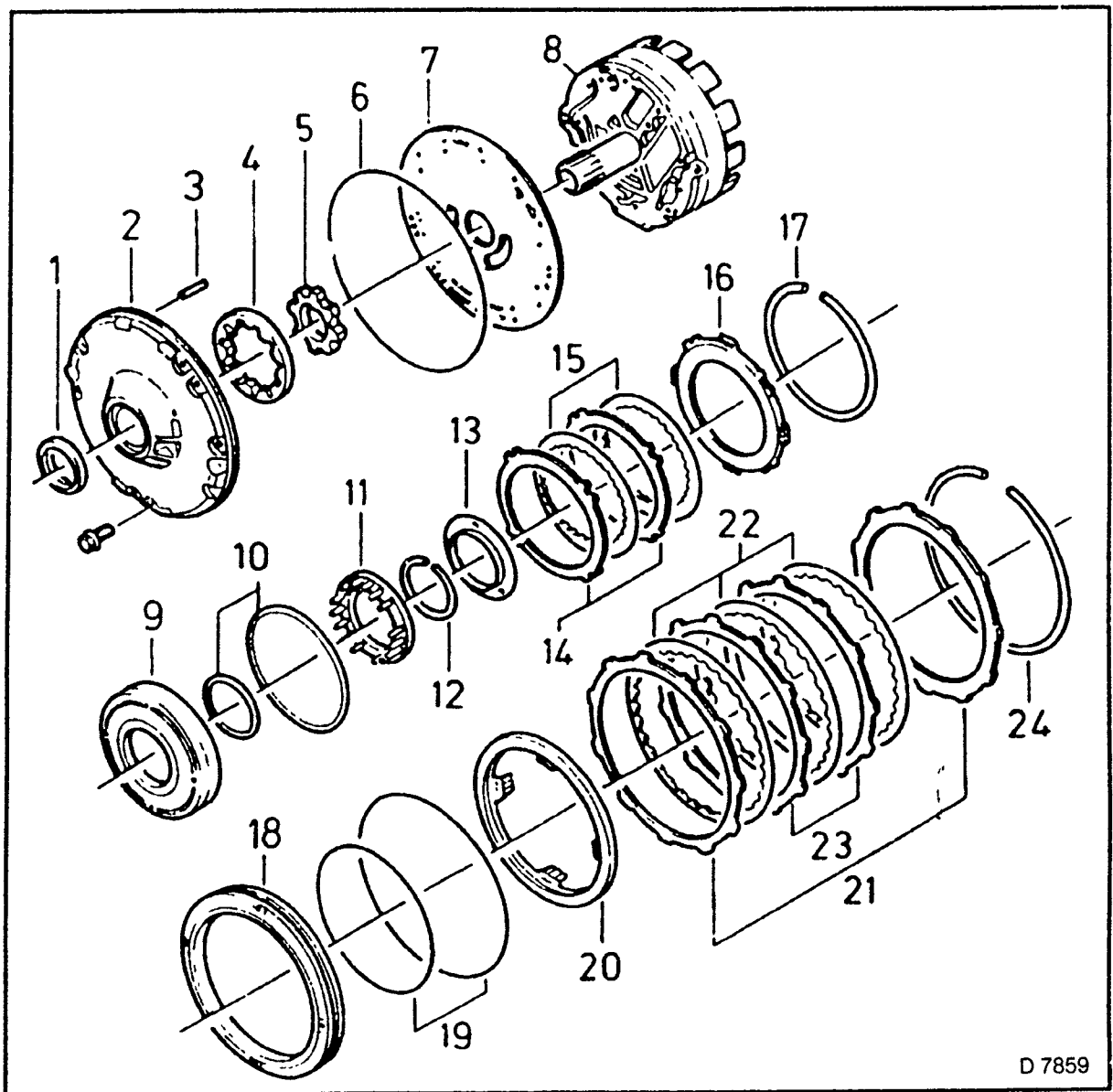


Fig. 331



D 7859

Fig. 332 — Fluid pump assembly.

- |                                |                                |
|--------------------------------|--------------------------------|
| 1 = Seal ring                  | 13 = Friction washer           |
| 2 = Pump housing               | 14 = Steel plates B1           |
| 3 = Centering pin              | 15 = Lining plates B1          |
| 4 = Driven gear                | 16 = Brake flange B1           |
| 5 = Drive gear                 | 17 = Retaining ring            |
| 6 = Seal ring                  | 18 = Piston B2                 |
| 7 = Fluid pump plate           | 19 = Seal rings                |
| 8 = Stator shaft               | 20 = Return spring assembly B2 |
| 9 = Piston B1                  | 21 = Brake flange B2 (x2)      |
| 10 = Seal rings                | 22 = Lining plates B2          |
| 11 = Return spring assembly B1 | 23 = Steel plates B2           |
| 12 = Retaining ring            | 24 = Retaining ring            |

## ASSEMBLIES, DISASSEMBLE AND ASSEMBLE

### Fluid Pump, Multi-disc Brakes B1 and B2 — Overhaul

#### INSPECT

1. Easy turnability of fluid pump drive gear — insert KM-704 in splines of fluid pump shaft and turn in both directions
2. Function of multi-disc brake B1.
3. Blow in compressed air (4 bar, arrow 2).
4. Piston must move uniformly and actuate inner lining plates.
5. Function of multi-disc brake B2.
6. Blow in compressed air (4 bar, arrow 1).
7. Piston must move uniformly and actuate outer lining plates.

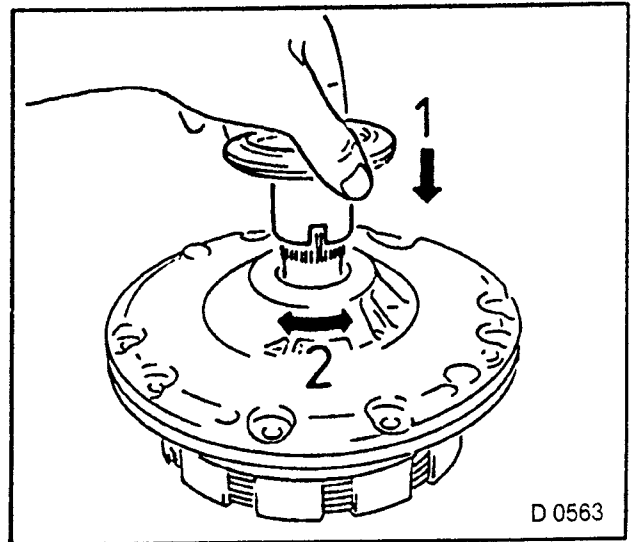


Fig. 333

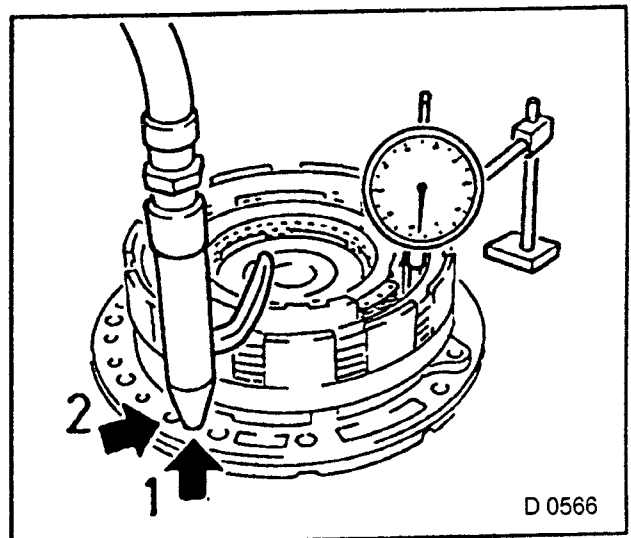


Fig. 334

#### DISASSEMBLE

1. Multi-disc brake B1.
2. Remove retaining ring (1).
3. Remove brake flange (2) and clutch plates.

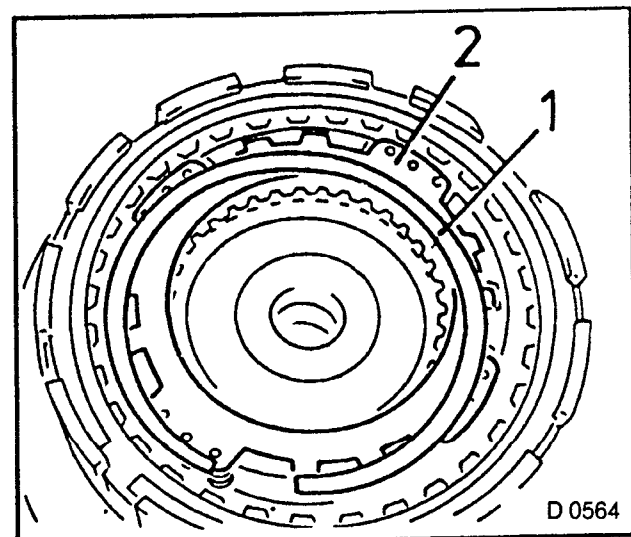


Fig. 335

4. Press together spring cup (1) with KM-699 (2) under a clamp.
5. Remove retaining ring.
6. Spring cup (1) from housing.

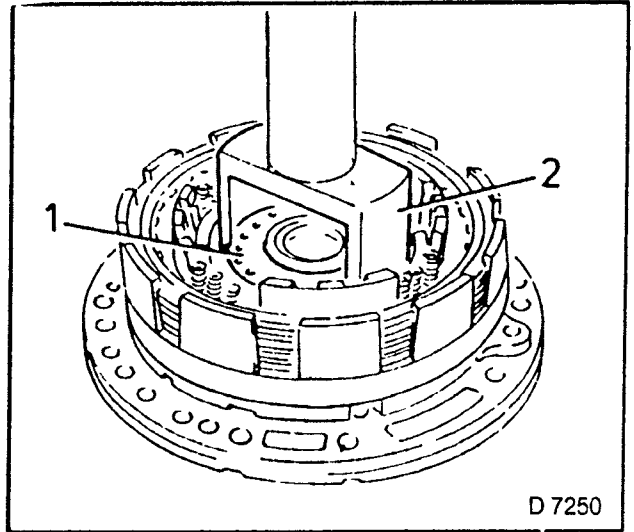


Fig 336

**REMOVE, DISCONNECT**

1. Piston for freewheel F1 — blow in low pressure air (arrow), if necessary assist with pliers.
2. Renew rubber O-seal rings (2)

**INSPECT**

1. Sliding surfaces of lining plates for wear — if necessary, replace.  
Before installing, lay new lining plates for at least two hours in transmission fluid.

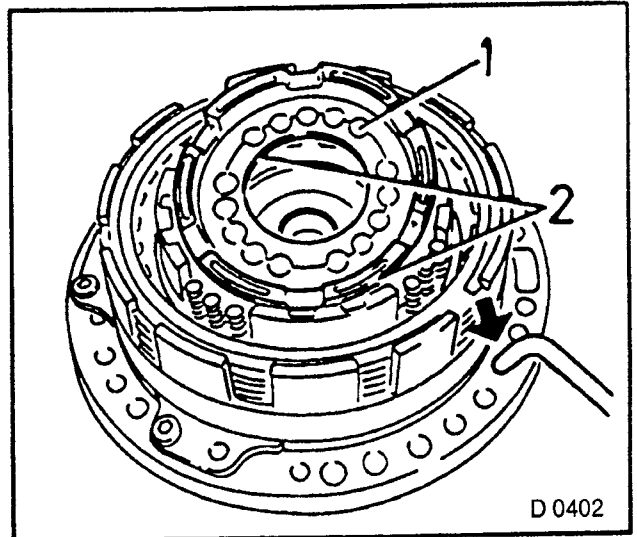
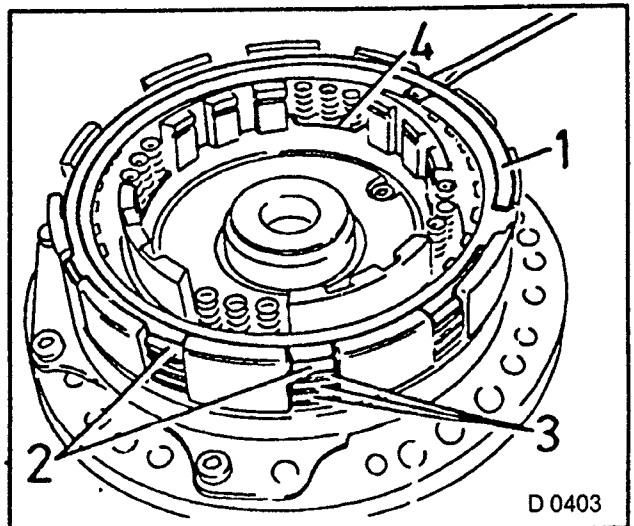


Fig 337

**DISASSEMBLE**

1. Multi-disc brake B2.
2. Remove retaining ring (1).  
Remove brake flange (2),  
Lining plates (3 pieces),  
Steel plates (3 pieces),  
Return spring assembly (4).



D 338



**REMOVE, DISCONNECT**

1. Piston for multi-disc brake B2 (1) — blow in low pressure air (arrow), if necessary assist with pliers.
2. Renew seal rings (2).

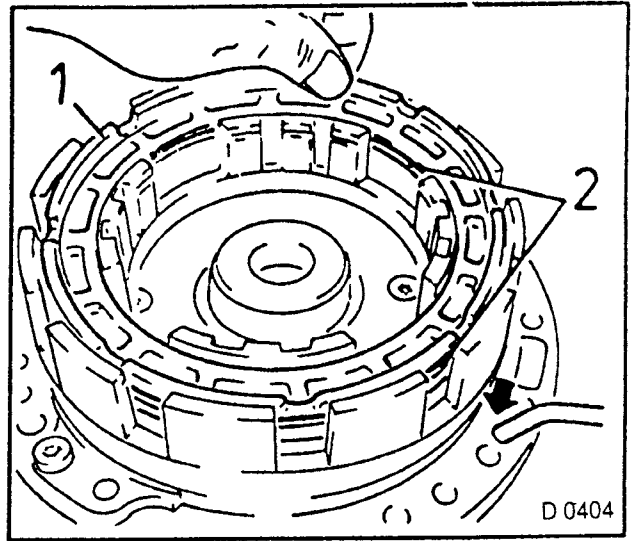


Fig. 339

**DISASSEMBLE**

1. Fluid pump,  
Fourteen bolts (Torx 30), fluid pump plate from pump housing (mark top side).

**INSPECT**

1. Both sides of plate for wear and scoring.

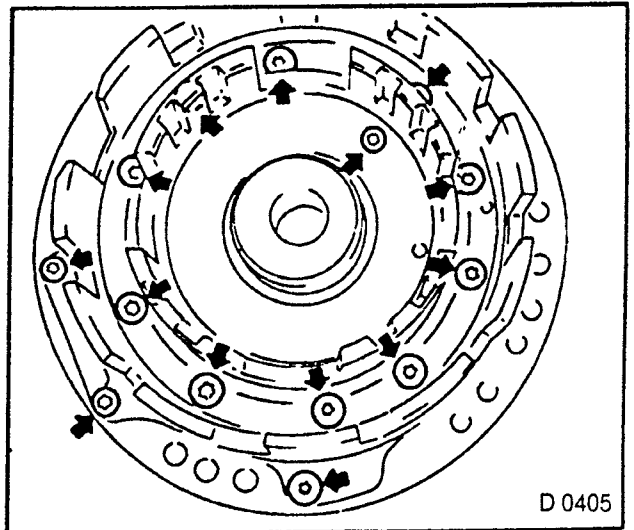


Fig. 340

**MEASURE**

1. Play between driven gear (1, press to one side of housing) and pump housing — feeler gauge (3).  
Measurement value: 0.075 to 0.2 mm

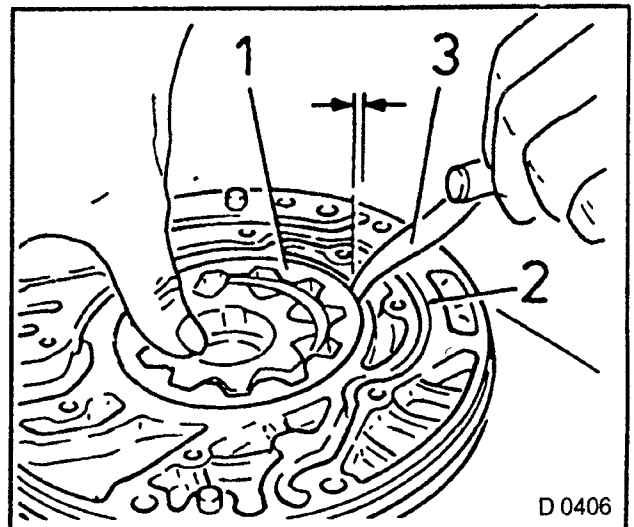


Fig. 341

2. Bottom play between drive gear (1) and crescent-shaped part (2) — feeler gauge (3).

Measurement value: 0.015 to 0.34 mm.

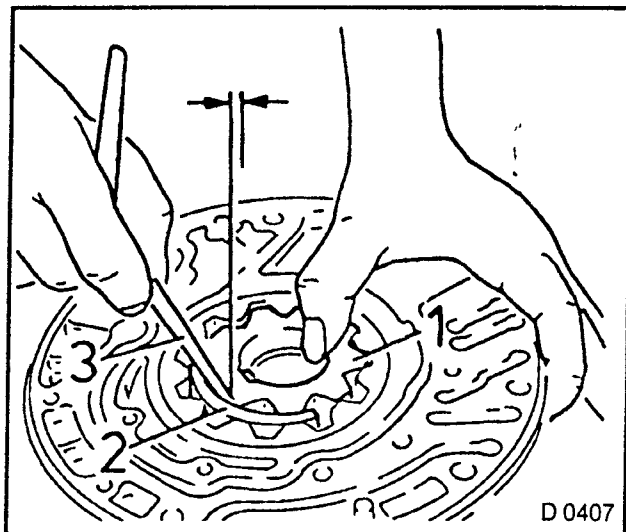


Fig 342

## MEASURE

- 1 Bottom play between driven gear (1) and crescent-shaped part (2) — feeler gauge (3).

Measurement value: 0.005 to 0.3 mm.

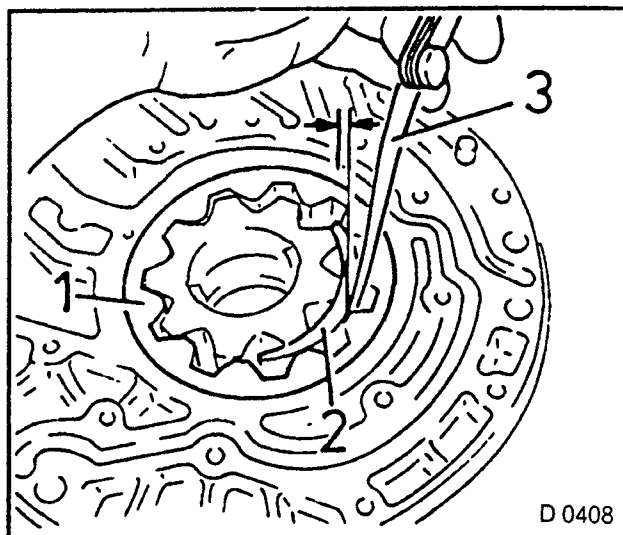


Fig 343

2. Axial play between both gears (1) and pump housing (2) — feeler gauge (3), steel ruler (4)

Measurement value: 0.02 to 0.05 mm  
wear limit 0.1 mm.

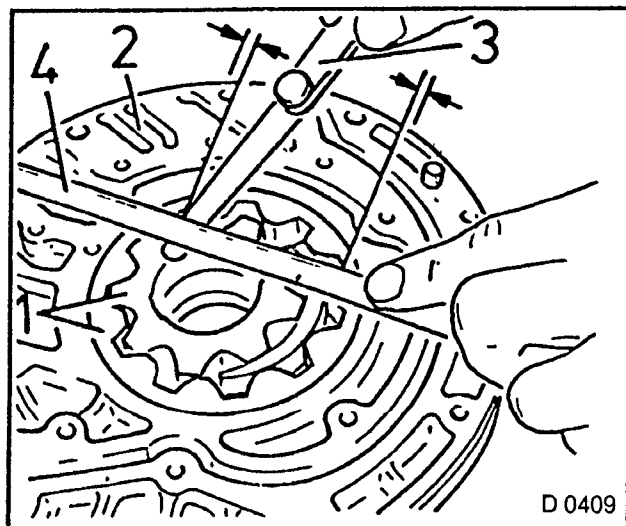


Fig 344

**REMOVE, DISCONNECT**

1. Both gears from fluid pump — mark top side of each.
2. Fluid seal ring from pump housing with suitable drift. Do not damage seating in housing.

**INSPECT**

1. Running surfaces and tooth profiles of both gears, carrier of drive gear (arrows) for damage and wear. If necessary, replace both gears — driving and driven.

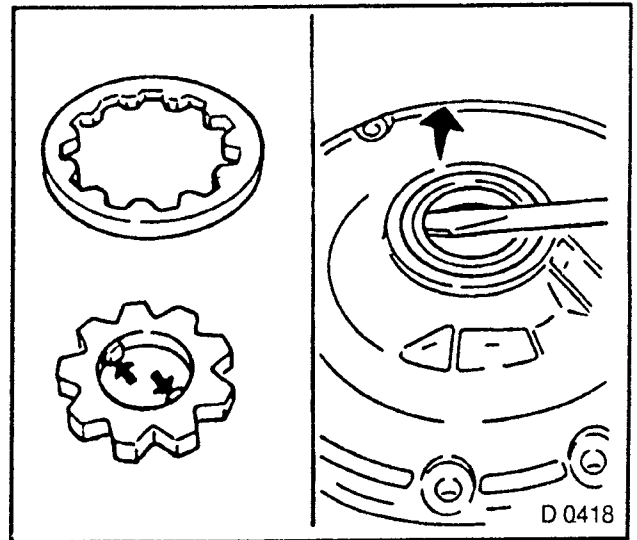


Fig 345

**MEASURE**

1. Inner diameter of bushing in pump housing (1).
2. Gauge with probe for inner diameter, measure at different points, take average. Measurement value: 38.113 to 38.180 mm. If necessary replace pump housing.
3. Inner diameter of front (2) and rear stator shaft bushing (3) — same measurement as before. Measurement value: 21.5 to 21.57 mm. If necessary replace stator shaft.

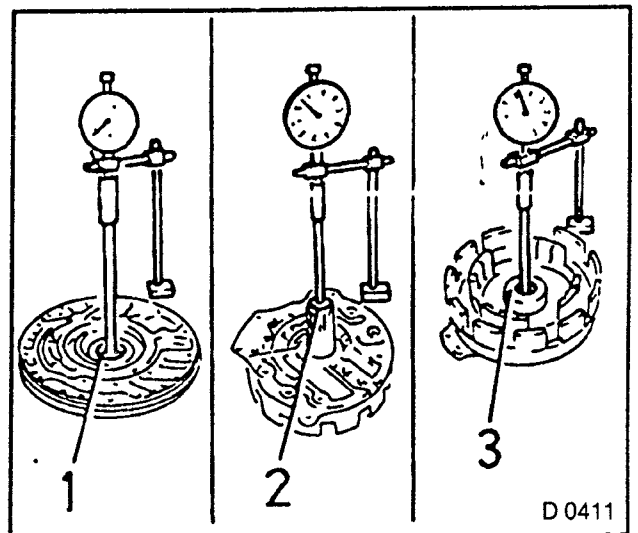


Fig. 346

**ASSEMBLE**

1. Fluid pump.
2. Drive in new fluid seal ring flush as far as upper edge of housing — KM-674. Fig. 347 shows procedure with fluid pump installed.

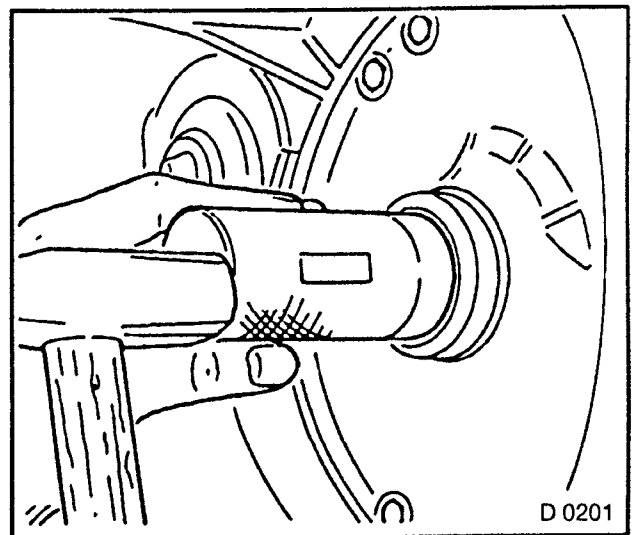


Fig 347

3. Both gears in pump housing — note marking.
- 4 Fluid pump plate to pump housing (dowel pin and marking)
- 5 New rubber O-seal ring between fluid pump plate and pump housing.

### TIGHTEN (TORQUE)

1. Stator shaft to fluid pump — (Torx 30), 12 Nm.

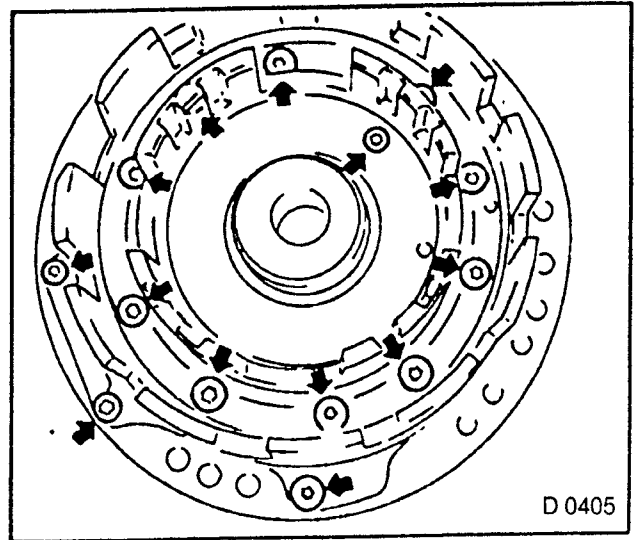


Fig 348

### INSPECT

1. Easy turnability of fluid pump drive gear — insert KM-704 in splines of fluid pump shaft and turn in both directions

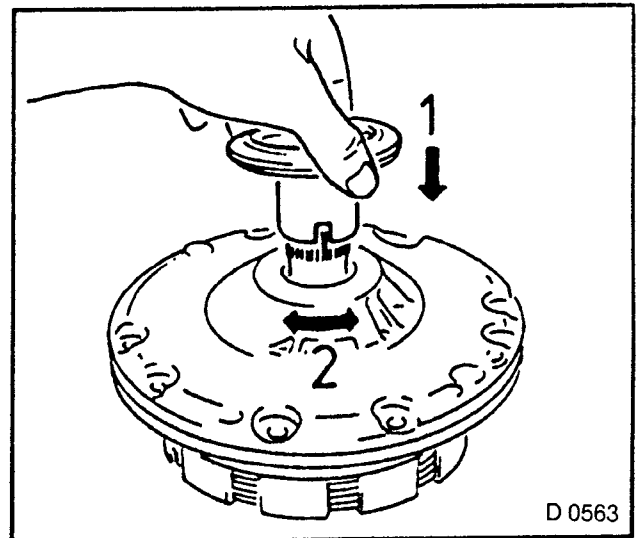


Fig 349

### ASSEMBLE

1. Multi-disc brake B2.
2. Insert piston for multi-disc brake B2 with new rubber O-seal rings in stator shaft (spring mounts point upwards).
- 3 Place return spring assembly on piston.
4. Alternately install steel plates and lining plates (three), steel plate first, steel flange last (rounded side points towards lining).
5. Insert retaining ring.

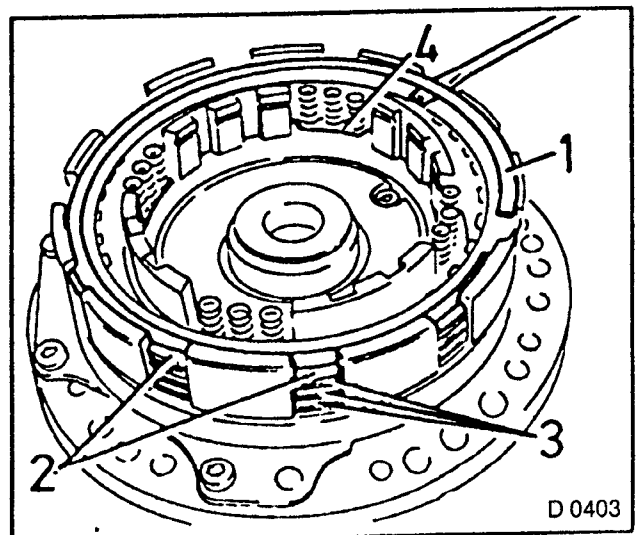


Fig 350

**ASSEMBLE**

1. Multi-disc brake B1.
2. Insert piston for freewheel F1 with new rubber O-seal rings in stator shaft (spring mounts point upwards)
3. Insert spring cup (1) and compress with KM-699 (2) in clamp.
4. Insert retaining ring
5. Alternately install steel plates and lining plates, steel plate first, steel flange last (rounded side points towards lining).
6. Insert retaining ring.

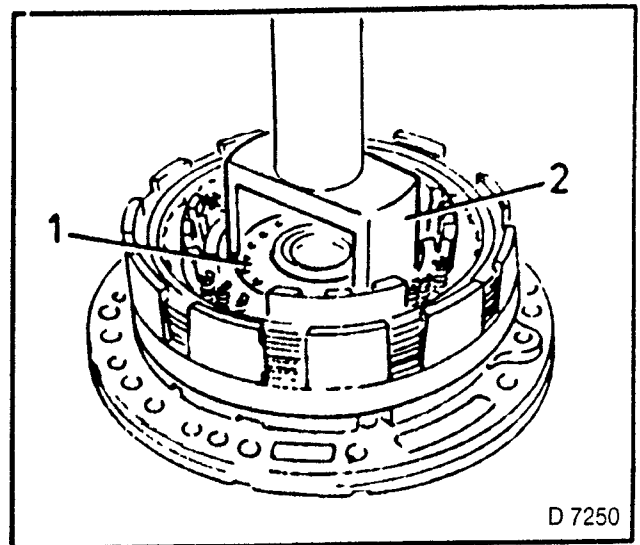


Fig 351

**MEASURE**

1. Piston stroke of multi-disc brake B2 — with gauge.
2. Blow in low pressure air (4 bar, arrow 1).
3. Place probe on uppermost lining plate. Measurement value: 1.14 to 1.86 mm.
4. Piston stroke of multi-disc brake B1 — with gauge.
5. Blow in low pressure air (4 bar, arrow 2).
6. Place probe on uppermost lining plate. Measurement value: 0.76 to 1.44 mm.

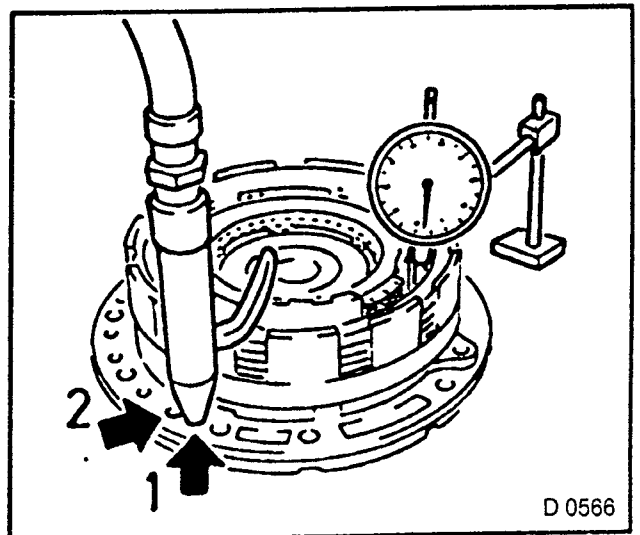
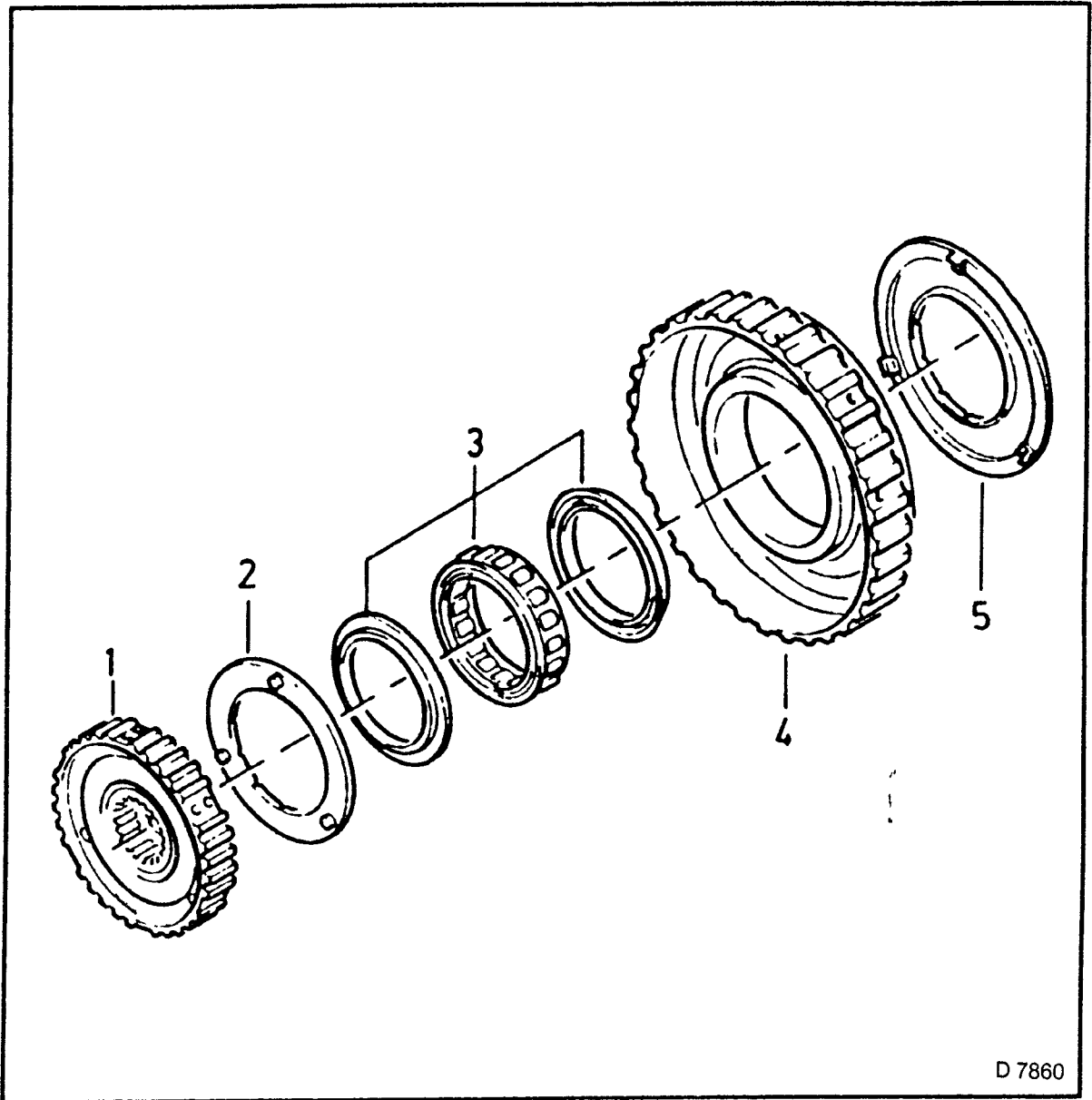


Fig 352



D 7860

Fig 353 — Freewheel F1

- 1 = Inner gear (freewheel brake hub)
- 2 = Friction washer
- 3 = Freewheel F1
- 4 = Outer gear (2nd gear brake hub)
- 5 = Friction washer

## Freewheel F1, Overhaul

### INSPECT

1. Freewheel clutch function.
2. Hold outer gear fixed, inner gear must turn clockwise (1) and lock counter-clockwise (2).

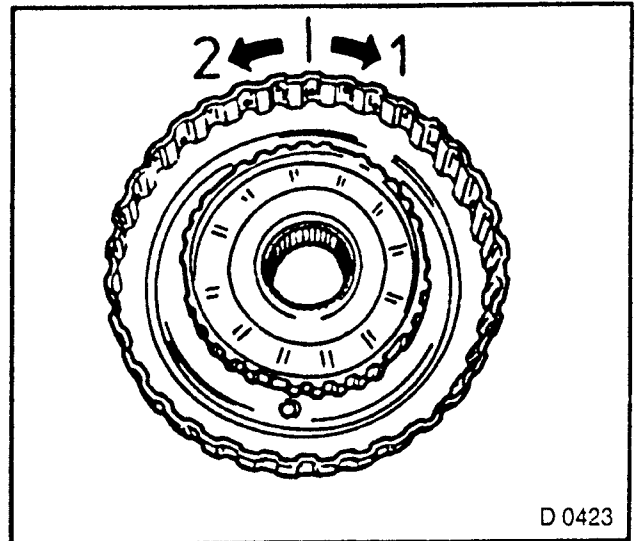


Fig 354

### DISASSEMBLE

1. Freewheel clutch F1.
2. Friction washer (1) from outer gear (2).
3. Inner gear (3) from outer gear (2)
4. Friction washer (4) from inner gear
5. Freewheel F1 (5) from outer gear

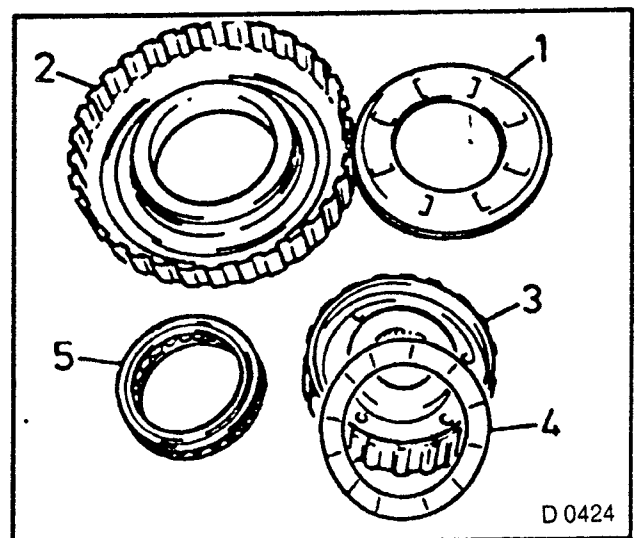


Fig 355

### ASSEMBLE

1. Freewheel clutch
2. Freewheel F1 (1) in outer gear (2) — installation direction: collar of freewheel — visible after removal of cover (3) — towards open side of outer gear.

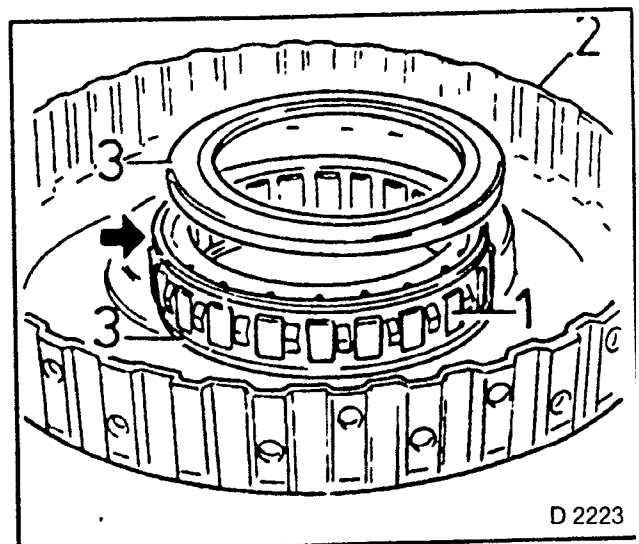


Fig 356

- 3 Friction washer (4) to inner gear (3) — note lug and recess
- 4 Inner gear (3) in outer gear (2) — turn and insert.
- 5 Friction washer (1) on outer gear (2) — note lug and recess

### INSPECT

1. Functioning of freewheel clutch — as described at beginning of overhaul.

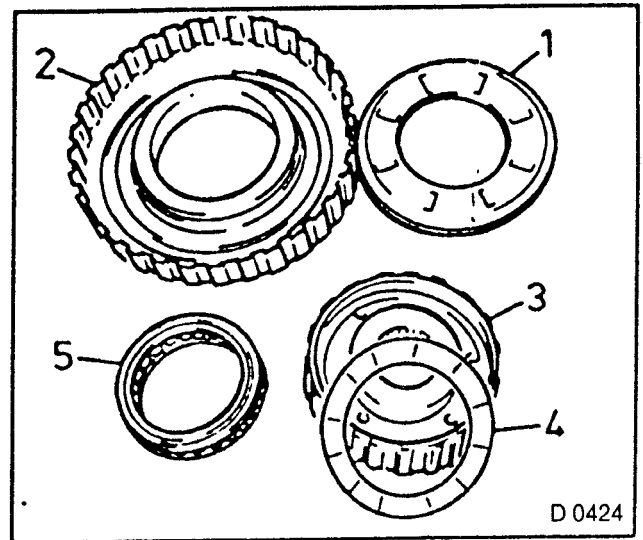
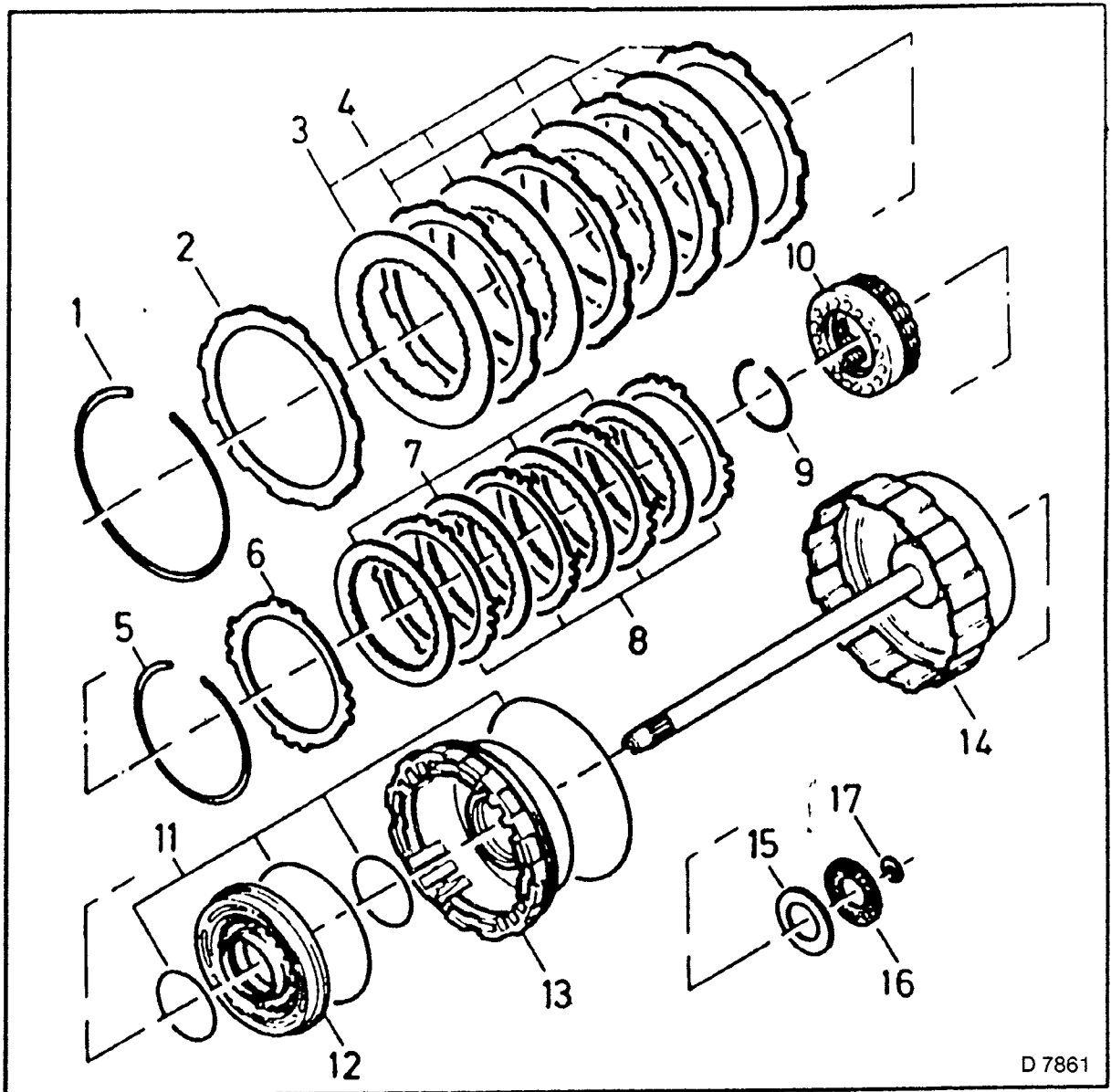


Fig. 357

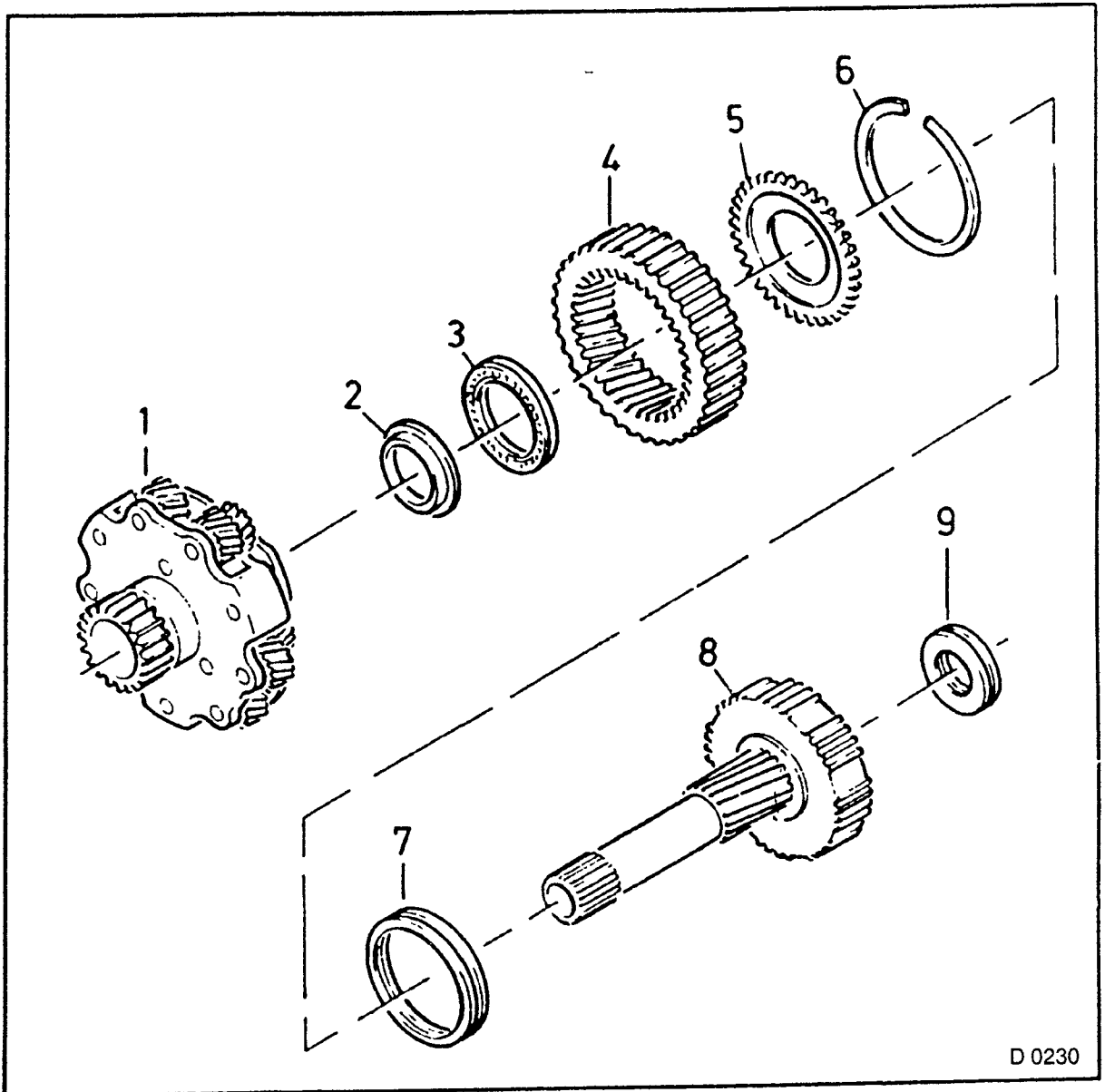




D 7861

Fig. 358 — Multi-plate Clutch C1 and C2 Assembly.

- 1 = Retaining ring
- 2 = Flange C1
- 3 = Lining plates C1
- 4 = Steel plates C1
- 5 = Retaining ring
- 6 = Flange C2
- 7 = Lining plates C2
- 8 = Steel plates C2
- 9 = Retaining ring
- 10 = Return spring assembly
- 11 = Rubber O-seal rings (4 pieces)
- 12 = Piston C2
- 13 = Piston C1
- 14 = Drive shaft
- 15 = Race
- 16 = Thrust bearing
- 17 = Seal ring



D 0230

Fig. 371 — Planetary Gear Set Assembly P1

- 1 = Planetary carrier
- 2 = Race
- 3 = Thrust bearing
- 4 = Rear internal gear
- 5 = Flange
- 6 = Retaining ring
- 7 = Thrust bearing
- 8 = Sun gear
- 9 = Thrust bearing

## Multi-plate Clutch Assembly C1 and C2 — Overhaul

### INSPECT

1. Piston of multi-plate clutch C1 (1).
2. Install drive shaft on rear housing cover.
3. Seal rings at rear cover and at rear side of drive shaft must still be in place.
4. Blow in compressed air (approximately 4 bar, arrow 2), ensure free passage of piston.

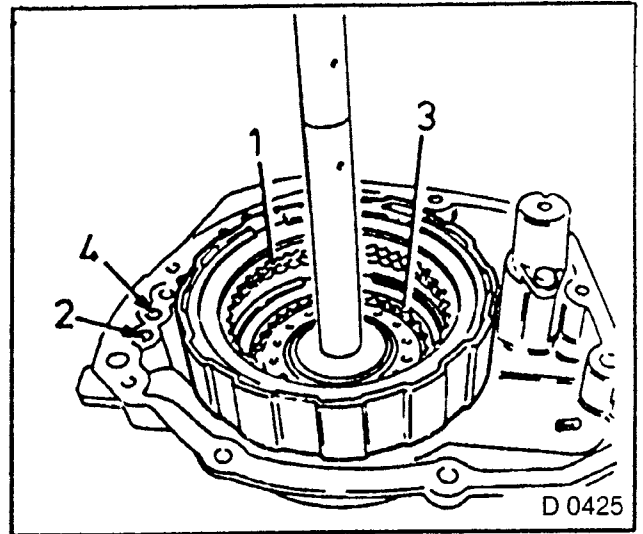


Fig. 359

5. Piston of multi-plate clutch C2 (3).
6. Same check as above, compressed air in bore (4).
7. Pistons (1 and 3) are each located under the plate packet.

### DISASSEMBLE

1. Multi-plate clutch C1.
2. Remove retaining ring.
3. Remove flange, lining plates and steel plates.

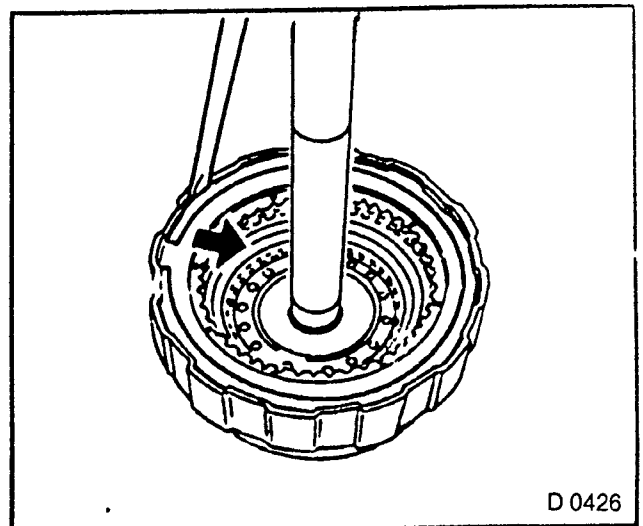


Fig. 360

4. Multi-plate clutch C2.
5. Same procedure as with multi-plate clutch C1.

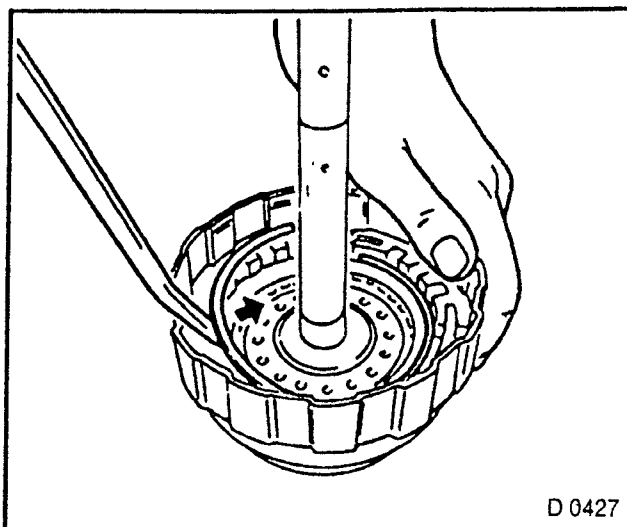


Fig 361

### REMOVE, DISCONNECT

1. Return spring assembly.
2. Place KM-698 (1) with KM-514 (2) and KM-697 or suitable pipe on spring cup (3) and compress using a clamp (arrows).
3. Loosen retaining ring (4) with KM-396.

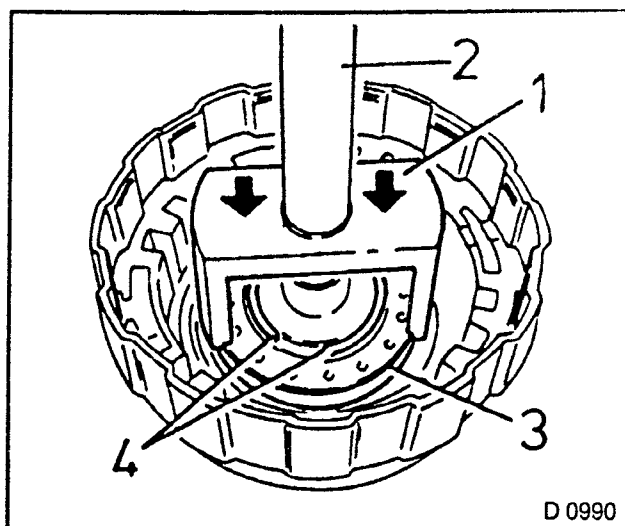


Fig. 362

4. Piston for multi-plate clutch C2.
5. Install drive shaft assembly at rear housing cover, blow in low pressure air (arrow), if necessary assist with pliers.
6. Renew rubber O-seal rings of piston.

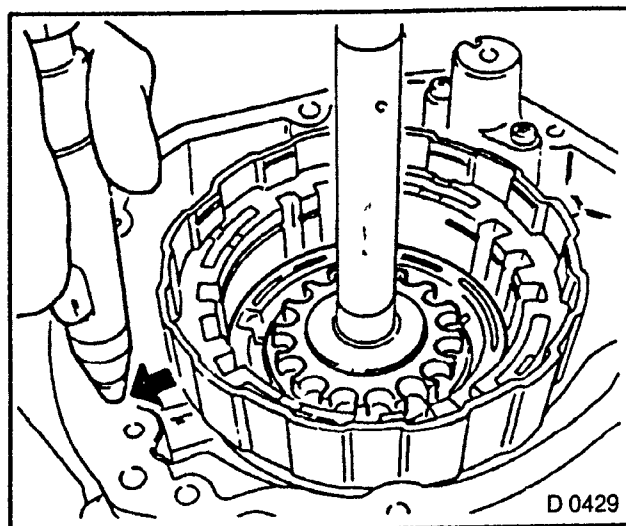


Fig. 363

**REMOVE, DISCONNECT**

1. Piston for multi-plate clutch C1.
2. Same procedure as with piston for multi-plate clutch C2.
3. Blow in compressed air in the neighbouring bore hole (arrow).

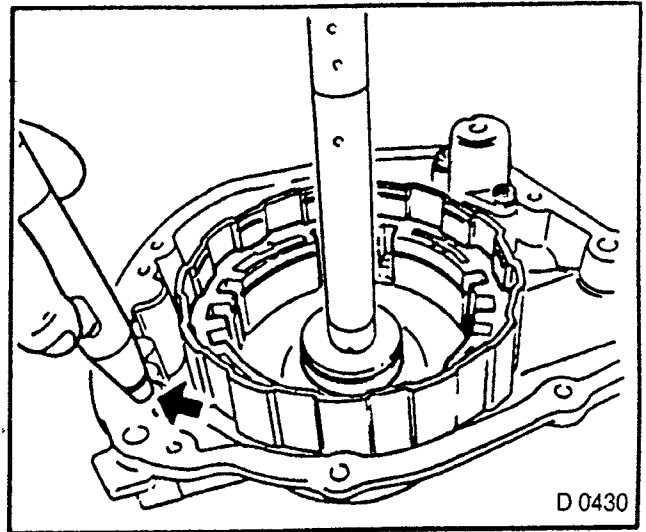


Fig. 364

4. Hook seal ring from drive shaft.
5. Take drive shaft from rear cover and clamp in vice.
6. Ring end is L-shaped — press one ring end into groove, hook out the other.
7. As cut seal ring without hooks on new transmissions.

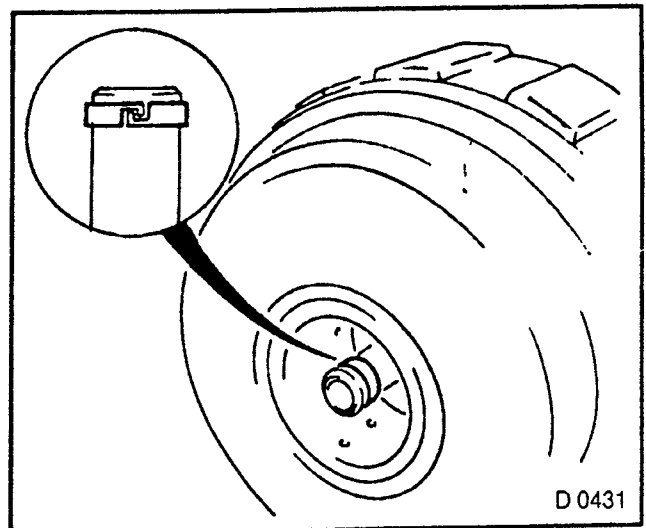


Fig 365

**INSPECT**

1. Sliding surfaces of lining plates and steel plates for damage and wear — if necessary, replace.
2. Before installing, lay new lining plates in transmission fluid for at least two hours.

**MEASURE**

1. Free spring lengths of return springs.  
Measurement value including spring cup:  
23.6 mm.

**INSPECT**

1. Lock ball of piston for multi-plate clutch C2.
2. Check by shaking that lock ball can move.
3. Check using low pressure air that valve is tight.

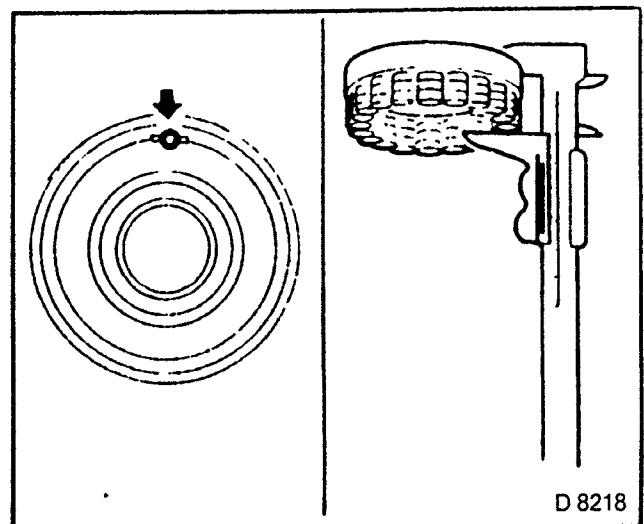


Fig. 366

**ASSEMBLE**

1. Multi-plate clutch C1 and C2.
2. Piston for multi-plate clutch C1 in drive shaft.
3. Piston for multi-plate clutch C2 in drive shaft.
4. Return spring assembly (3) onto piston C1 — compress with KM-698 (1) and KM-514 (2), KM-697 or suitable pipe using clamp.
5. Insert retaining ring (4) with KM-396.

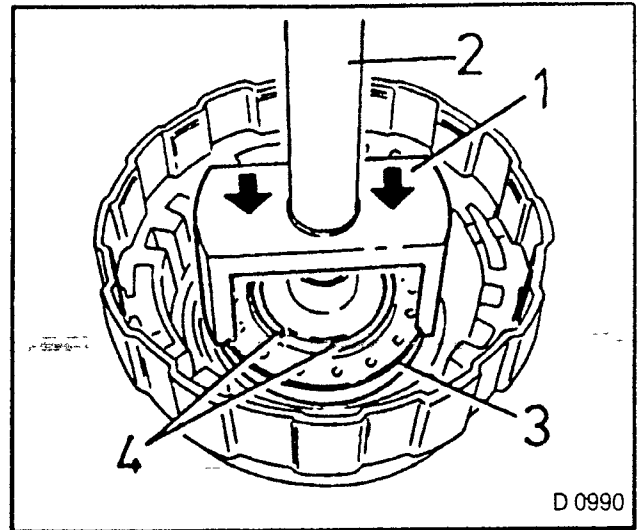


Fig 367

In each case alternately steel plate (first), lining plate and lastly flange (surfaces with rounded edge points towards lining plate) onto piston C1 or C2 — see exploded view Fig. 358.

5. Insert retaining ring for each.

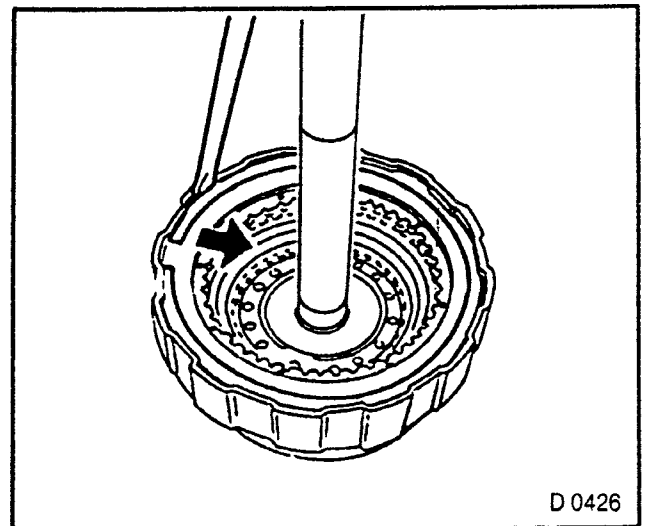


Fig 368

**INSTALL, CONNECT**

1. New hook seal ring on drive shaft.  
Do not expand more than necessary, place one ring end in groove, hook in the other.  
As cut seal ring without hooks on new transmissions.

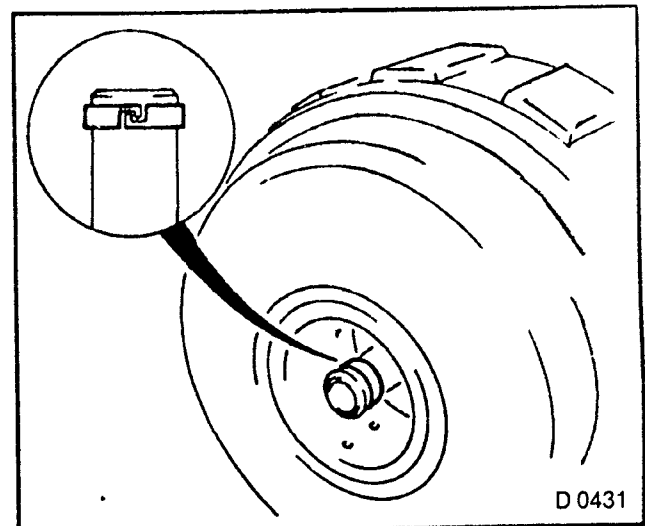


Fig. 369

**MEASURE**

1. Piston stroke of multi-plate clutch C1
2. Mount drive shaft in rear cover, blow compressed air in bore hole at rear cover (4 bar, arrow 1).
3. Place probe of gauge on the uppermost lining disc (3),  
Measurement values:  
Version with four lining discs: 1.52 to 1.89 mm,  
Version with three lining discs: 1.14 to 1.46 mm.
4. Piston stroke of multi-plate clutch C2 — same procedure and measurement values as with piston stroke C1
5. Place probe of gauge on flange of multi-plate clutch C2 (4).
6. Blow compressed air into corresponding bore hole (arrow 2).

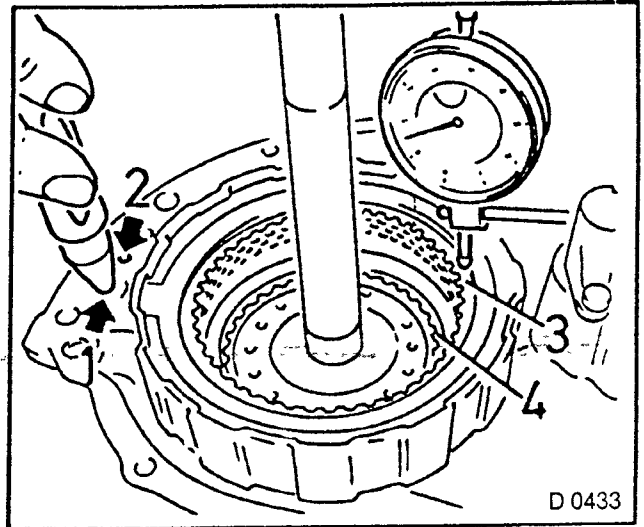


Fig 370

**Planetary Gear Set P1 — Overhaul****REMOVE, DISCONNECT**

1. Thrust bearing (1) from flange (2) — observe condition and installation position. If necessary replace.
2. Flange from rear internal gear.
3. Retaining ring (3).

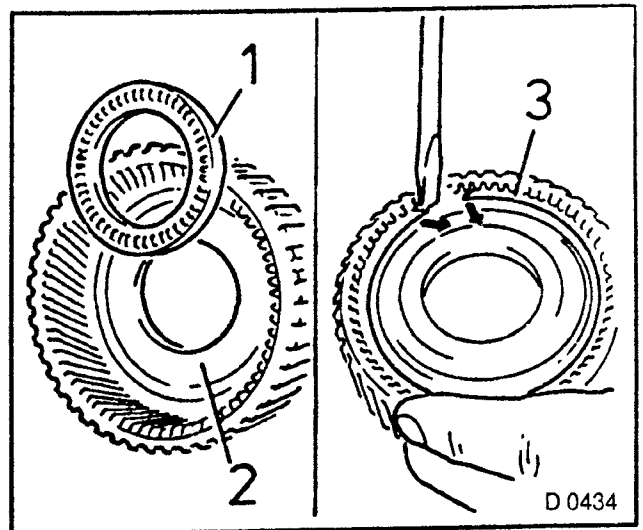


Fig 372

**INSTALL, CONNECT**

1. Flange (4) on rear internal gear (3).
2. Retaining ring (5).
3. Thrust bearing (2) to flange (4).
4. Friction washer (1) to thrust bearing (2).

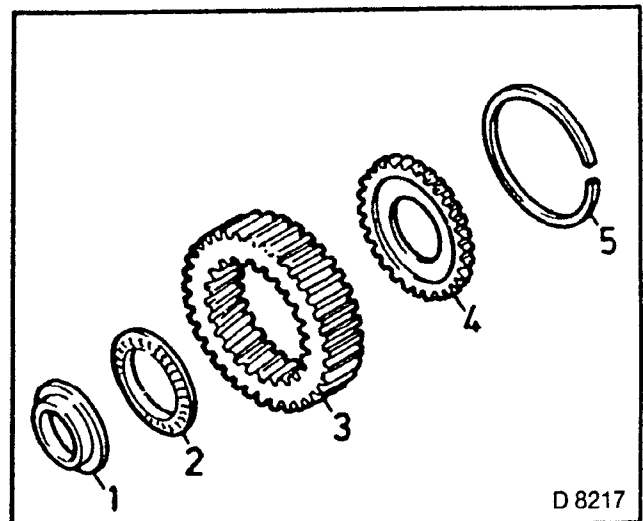


Fig. 373

D 8217

**MEASURE**

1. Inner diameter of planetary carrier bushing.
2. Gauge with probe for inner diameter, carry out several measurements, take average

Measurement value 30.0 to 30.026 mm, if necessary replace planetary carrier assembly

~~assembly~~

Play between planetary gears and housing — feeler gauge.

Measurement value:

For short gears: 0.20 to 0.60 mm

For long gears: 0.20 to 1.0 mm.

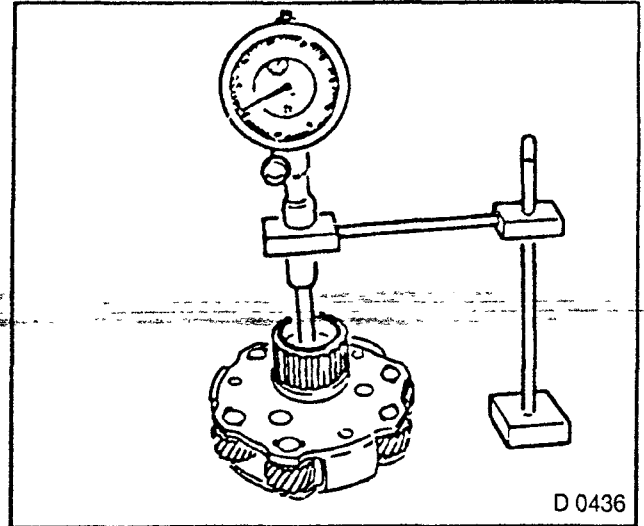


Fig. 374

3. Inner diameter of sun gear bushing.  
Same measurement as before.  
Measurement value: 21.501 to 21.527 mm

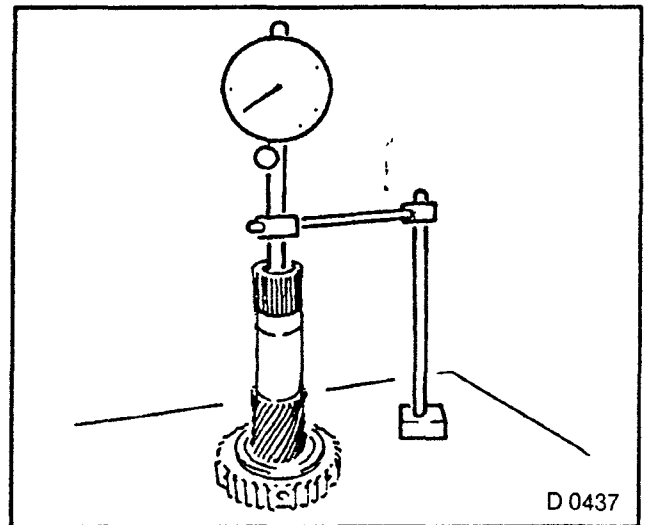
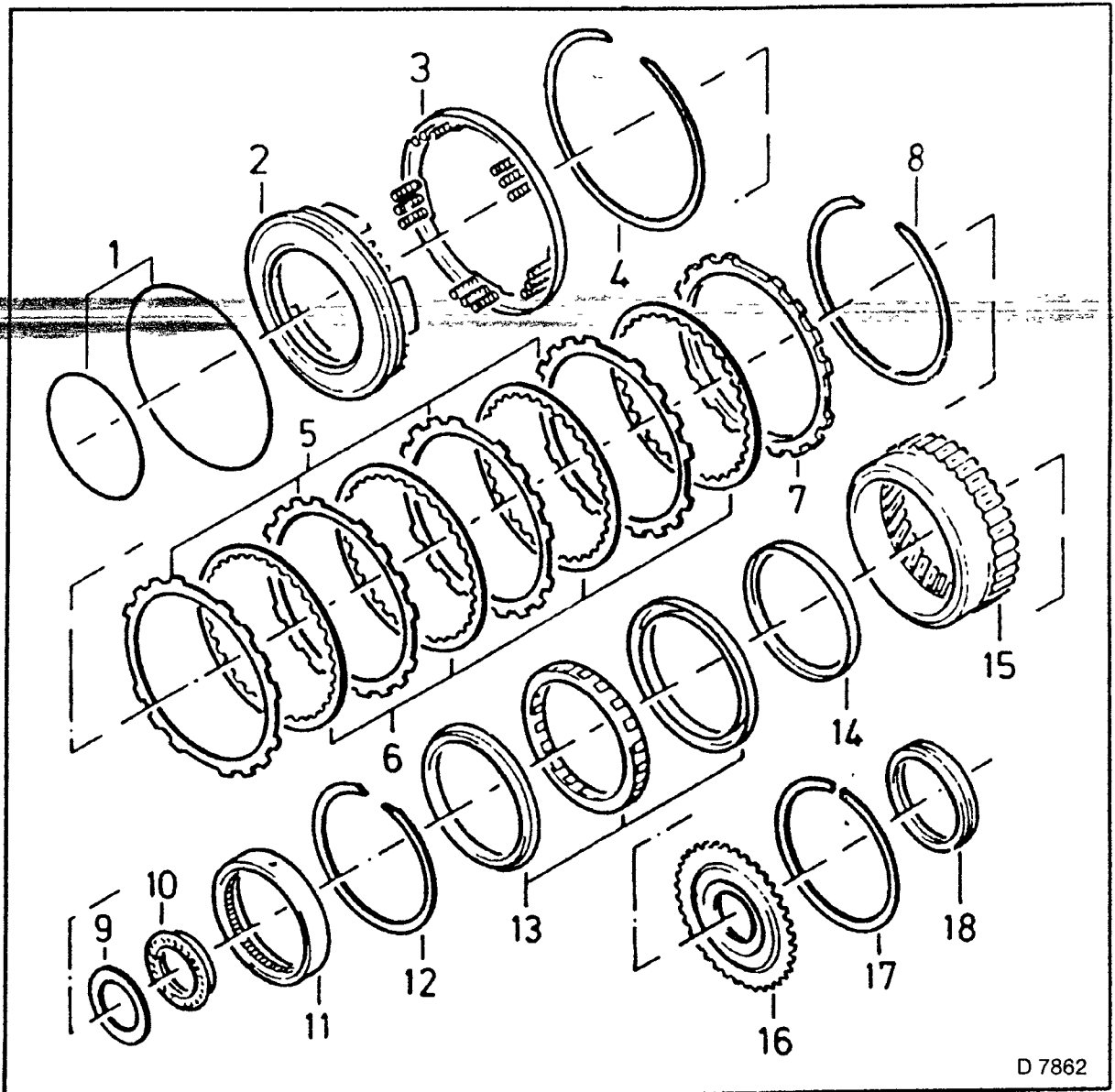


Fig. 375





D 7862

Fig 376 — Multi-disc Brake B3 and Freewheel F2

- 1 = Rubber O-seal ring
- 2 = Piston B3
- 3 = Return spring assembly
- 4 = Retaining ring
- 5 = Steel plates B3
- 6 = Lining plates B3
- 7 = Flange
- 8 = Retaining ring
- 9 = Friction washer
- 10 = Thrust bearing
- 11 = Freewheel inner race
- 12 = Retaining ring
- 13 = Freewheel F2
- 14 = Thrust washer
- 15 = Front internal gear
- 16 = Flange
- 17 = Retaining ring
- 18 = Friction washer

## Multi-disc Brake B3 and Freewheel F2 — Overhaul

MULTI-DISC BRAKE B3 REMOVED.

### INSPECT

1. Function of freewheel clutch.
2. Place freewheel clutch (1) and inner race (2) in front internal gear (3).
3. Hold internal gear fixed, inner race **must** turn counter-clockwise (4), and lock clockwise (5).

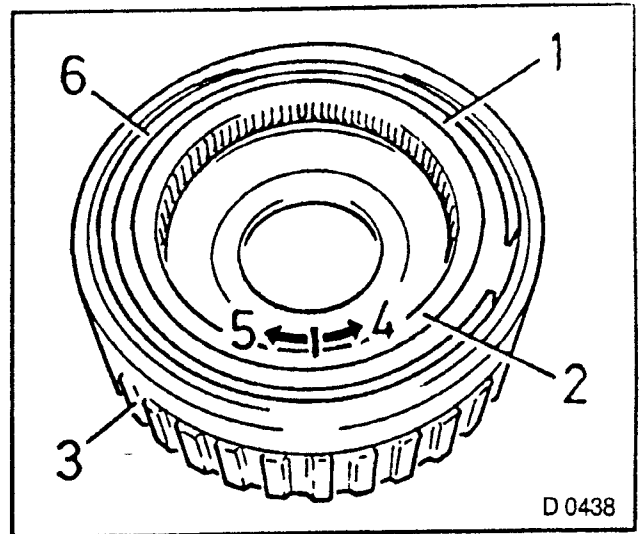


Fig. 377

### DISASSEMBLE

1. Freewheel clutch.
2. Set aside as installed bearing ring, thrust bearing (1), freewheel inner race (2).
3. Retaining ring (3) and Fig. 377, Item 6, Freewheel F2 (4), Friction washer (5).

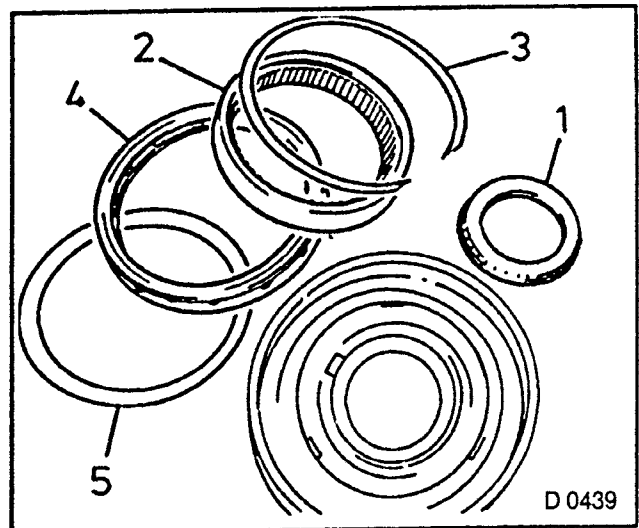


Fig. 378

### REMOVE, DISCONNECT

1. Thrust bearing (1).
2. Retaining ring (2).
3. Flange (3) from front internal gear (4).

### ASSEMBLE

1. Freewheel clutch — flange (3) in front internal gear (4) — ring pliers.

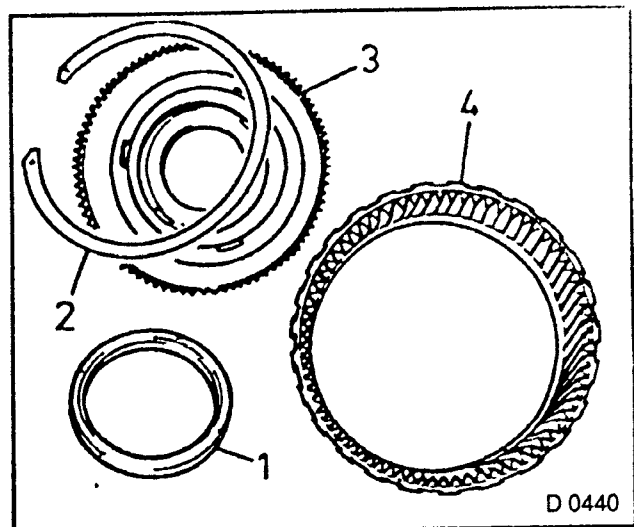


Fig. 379

2. Friction washer (5, flat surface points to flange)
3. Freewheel (4) in internal gear.  
(Installation direction: when the internal gear is held, freewheel can be turned anti-clockwise).
4. Insert retaining ring (3).
5. Freewheel inner ring (Fig. 380, Item 2).

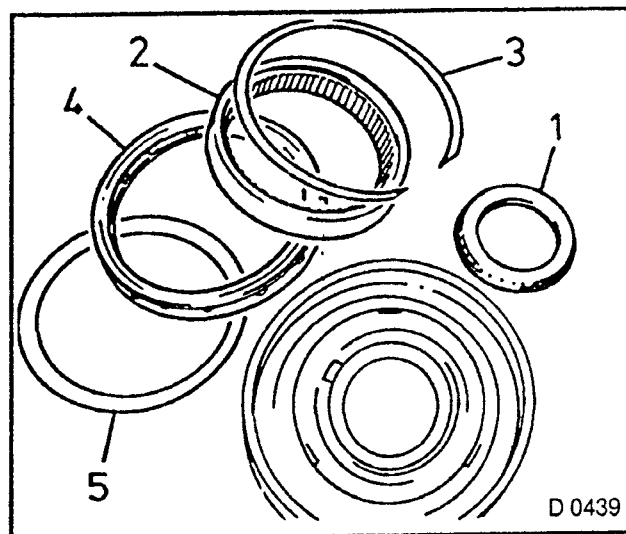
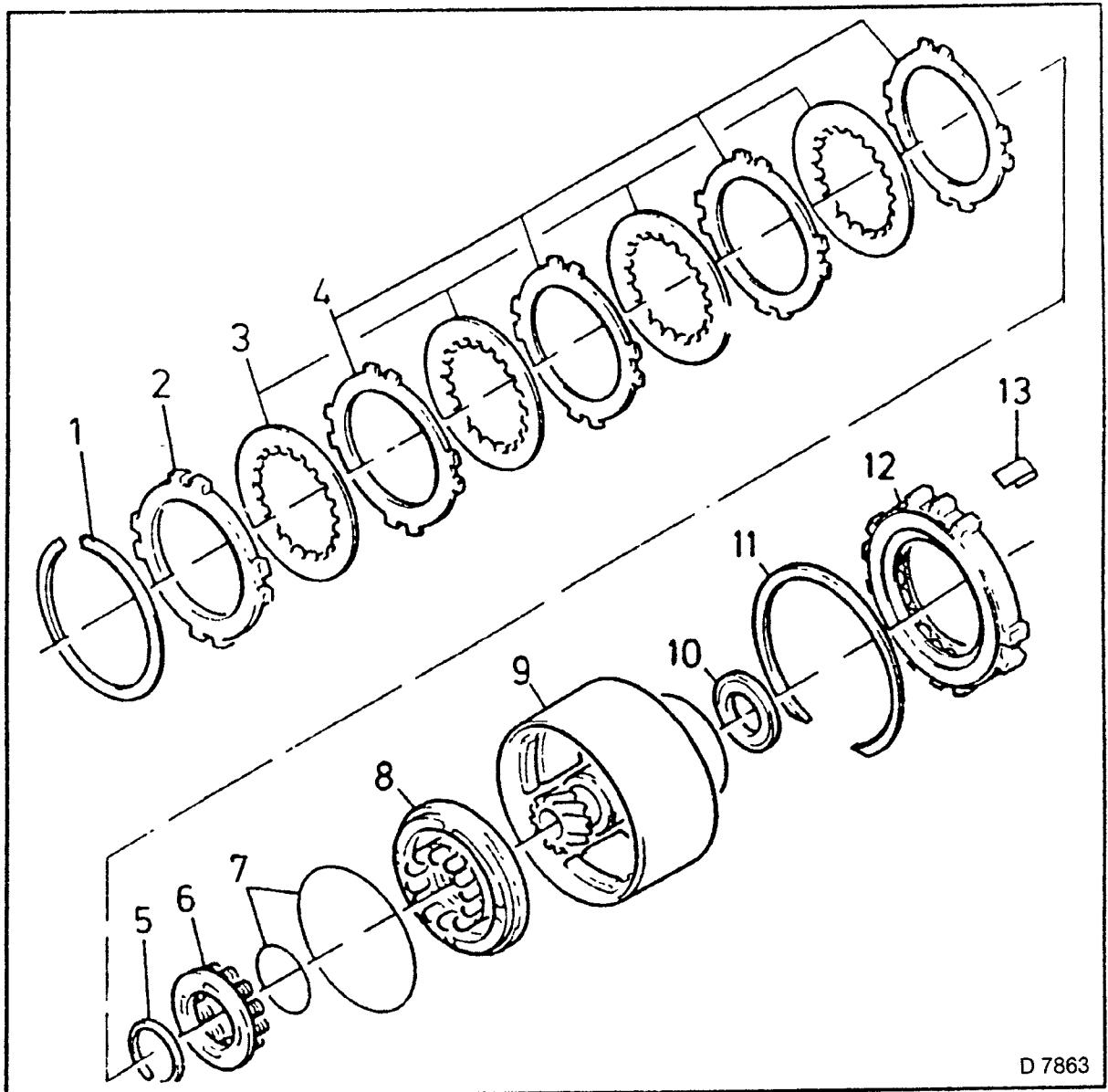


Fig 380



D 7863

Fig. 381 — Multi-plate Clutch C3 and Freewheel F3.

- 1 = Retaining ring
- 2 = Flange
- 3 = Lining plate C3
- 4 = Steel plate C3
- 5 = Retaining ring
- 6 = Return spring assembly
- 7 = Seal rings
- 8 = Piston C3
- 9 = Clutch body
- 10 = Thrust bearing
- 11 = Retaining ring
- 12 = Freewheel F3
- 13 = Freewheel F3 outer race, bracket

## Multi-plate Clutch C3 and Freewheel F3 — Overhaul

### DISASSEMBLE

1. Multi-plate clutch C3
2. Flange, lining plates and steel plates from clutch body.
3. Remove retaining ring (1).
4. Freewheel F3 (2) from clutch body.

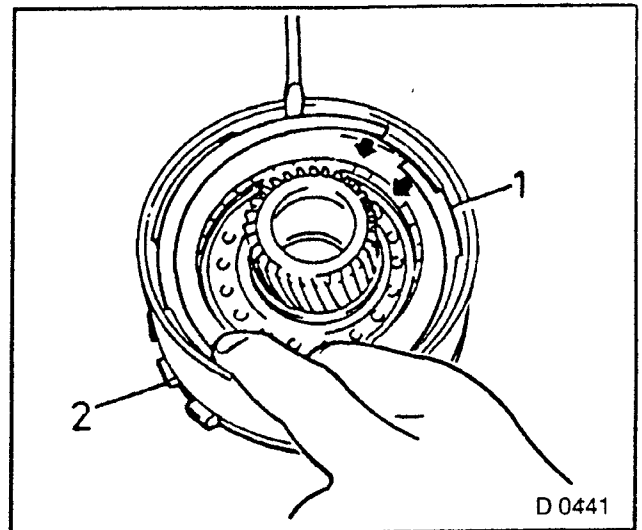


Fig. 382

5. Compress return spring assembly (1) in vice with protective jaws — KM-698 (2).
6. Loosen retaining ring (3) with KM-396.
7. Remove spring cup with springs.

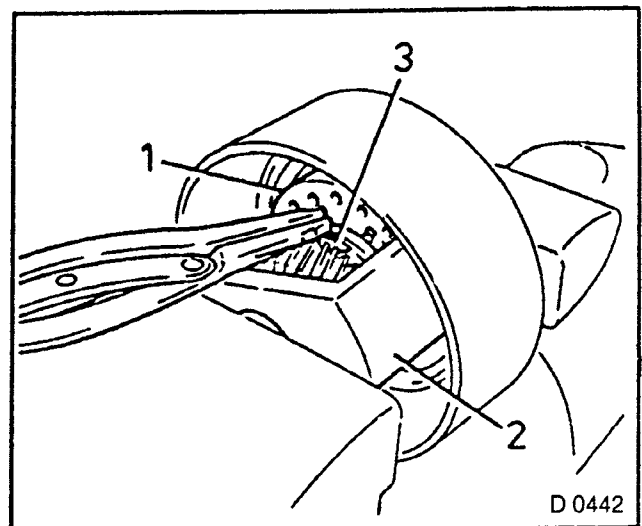


Fig. 383

### REMOVE, DISCONNECT

1. Piston C3 from clutch body.
2. Place clutch body in transmission.
3. Blow in low pressure air (arrow), if necessary assist with pliers.
4. Renew rubber O-seal rings (1) on piston.

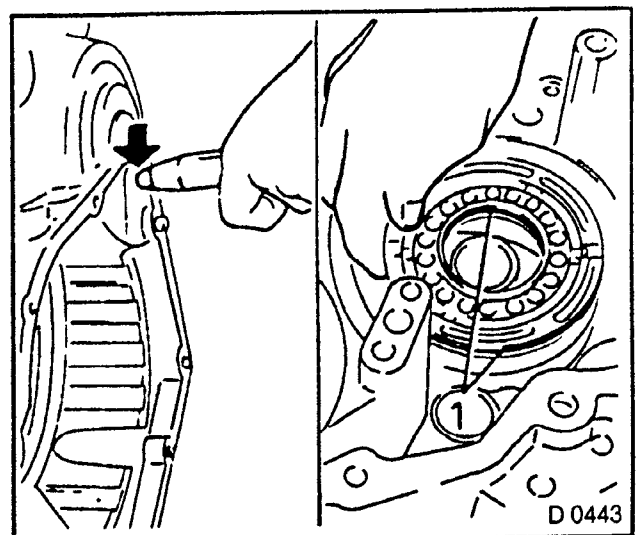


Fig. 386

**INSPECT**

1. Flange (1).
2. Lining plates (2).
3. Steel plates (3)  
for damage and wear — before installing.
4. Lay new lining plates in transmission fluid for at least two hours

**MEASURE**

1. Free spring lengths of return springs.  
Measurement value including spring cup (4):  
20 mm — note that all springs must have  
same length.

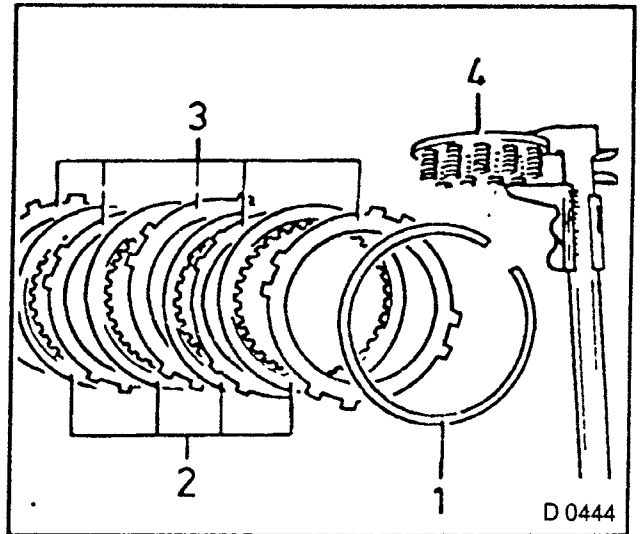


Fig. 387

**INSPECT**

1. Lock ball of piston C3.
2. Check by shaking that lock ball (1) can be moved.
3. Check with low pressure air (arrow) that valve is tight

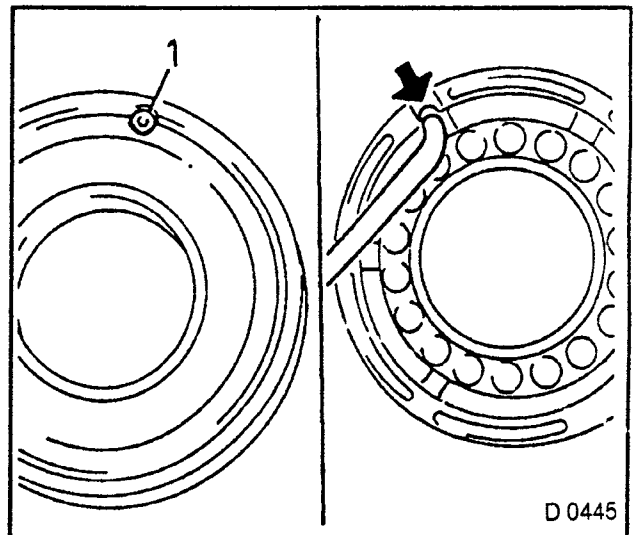


Fig. 388

**MEASURE**

1. Inner diameter of front and rear clutch body bushings — gauge with probe for inner diameter.  
Carry out several measurements, take average.

Measurement value: 28.5 to 28.525 mm.

If worn, replace clutch body; the bushings cannot be replaced individually.

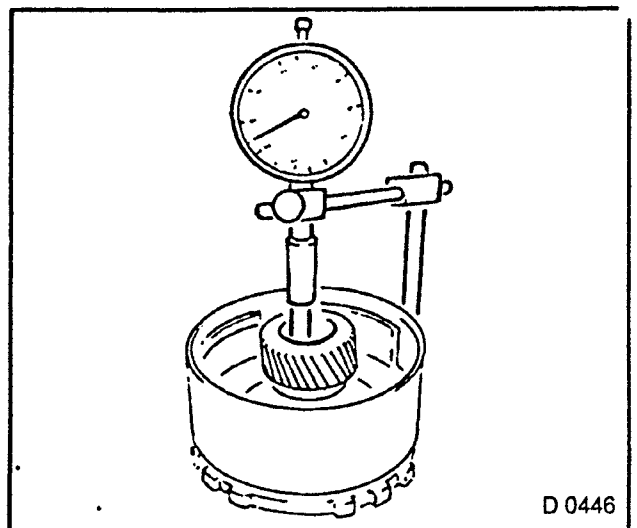


Fig. 389

**INSPECT**

1. Clutch body for damage or wear.
2. Contact surface of seal rings (1).
3. Contact surface of freewheel (2).
4. Contact surface of brake band (3).
5. Replace clutch body if necessary.

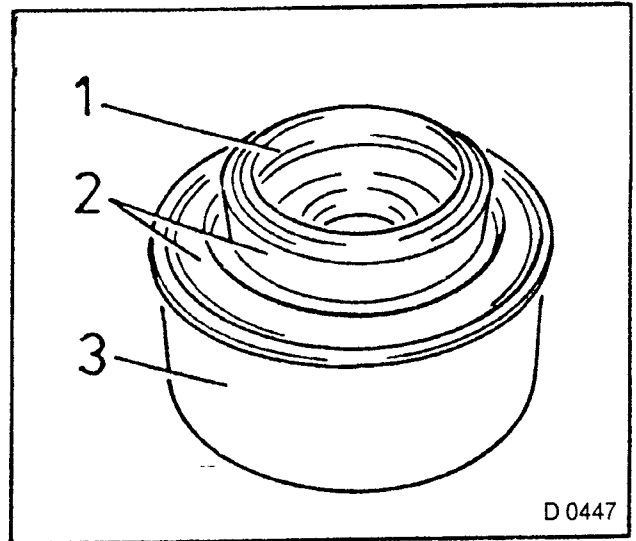


Fig. 390

**ASSEMBLE**

1. Multi-plate clutch C3.
2. Insert piston C3 in clutch body (spring mount points upwards).
3. Place return spring assembly and retaining ring on piston C3.

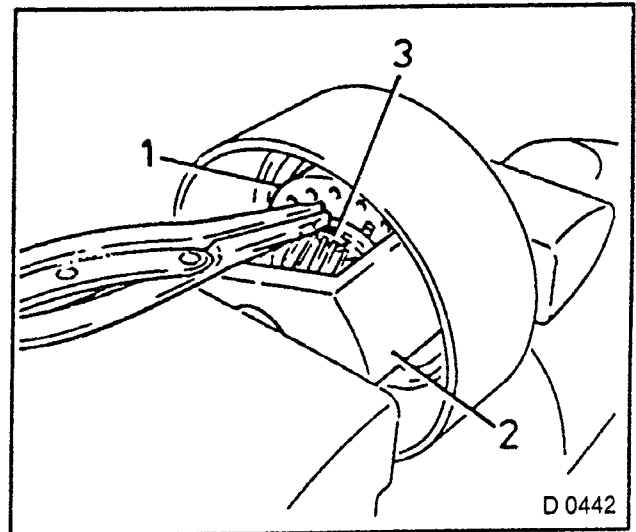


Fig. 391

**ASSEMBLE**

1. Multi-plate clutch C3.
2. Compress spring plate (1) in vice — KM-698 (2).
3. Install retaining ring (3) with KM-396.

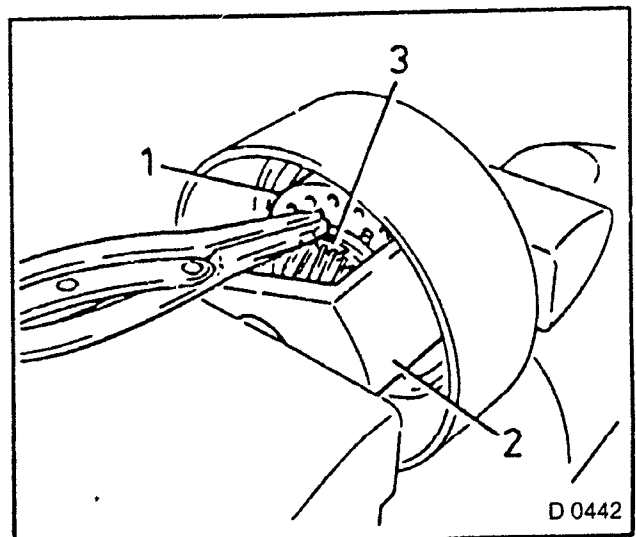


Fig. 392

4. Alternate with steel plate (3) first, then lining plate (2), lastly flange — rounded side points towards lining plate
5. Insert retaining ring (1).

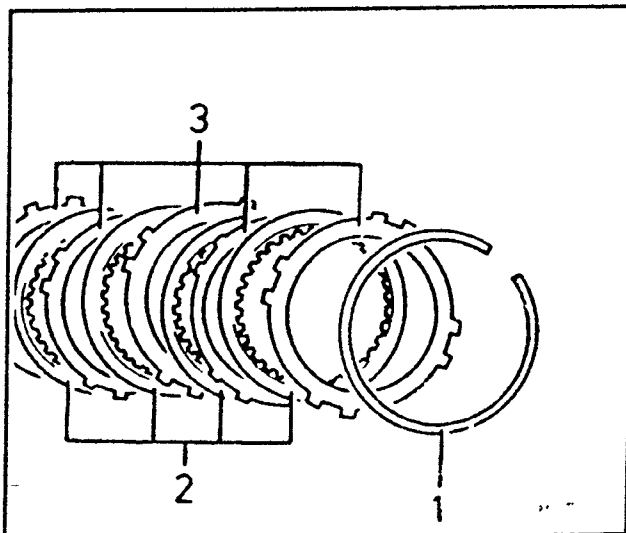


Fig. 393

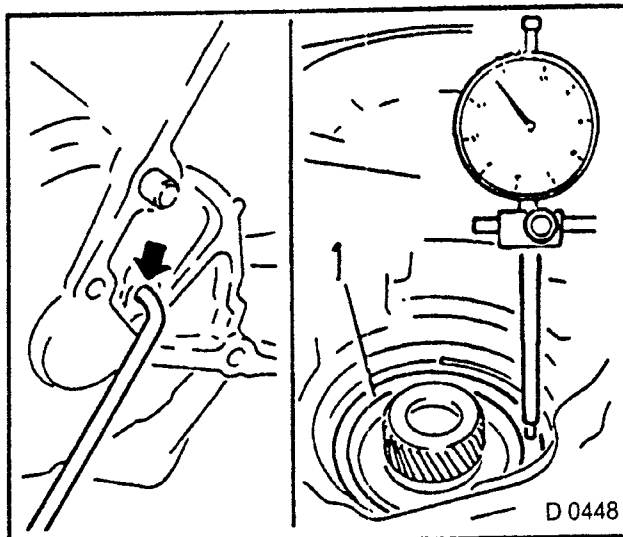
**MEASURE**

1. Piston stroke of multi-plate clutch C3.
2. Insert clutch body in transmission.
3. Place gauge on flange (1) blow in compressed air (4 bar, arrow).

Measurement value:

With 4 lining plates: 1.52 to 1.89 mm.

With 3 lining plates: 1.14 to 1.46 mm.

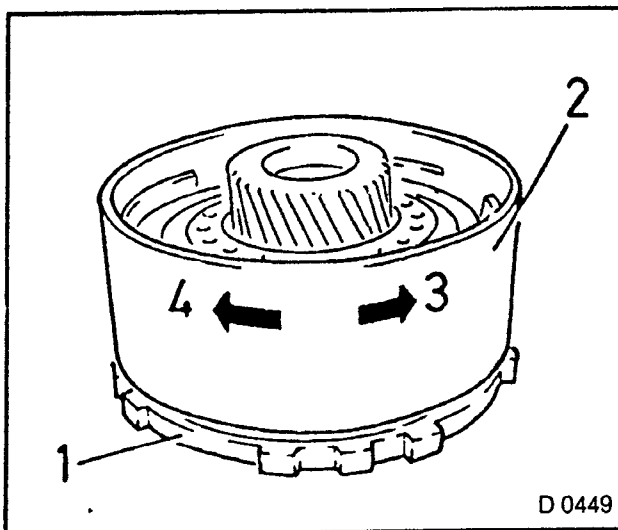


D 0448

Fig. 394

**INSPECT**

1. Function of freewheel F3.
2. Install freewheel (1) on clutch body (2).
3. Hold freewheel fixed, clutch body must be turnable counter-clockwise (3) and lock clockwise (4).



D 0449

Fig. 395



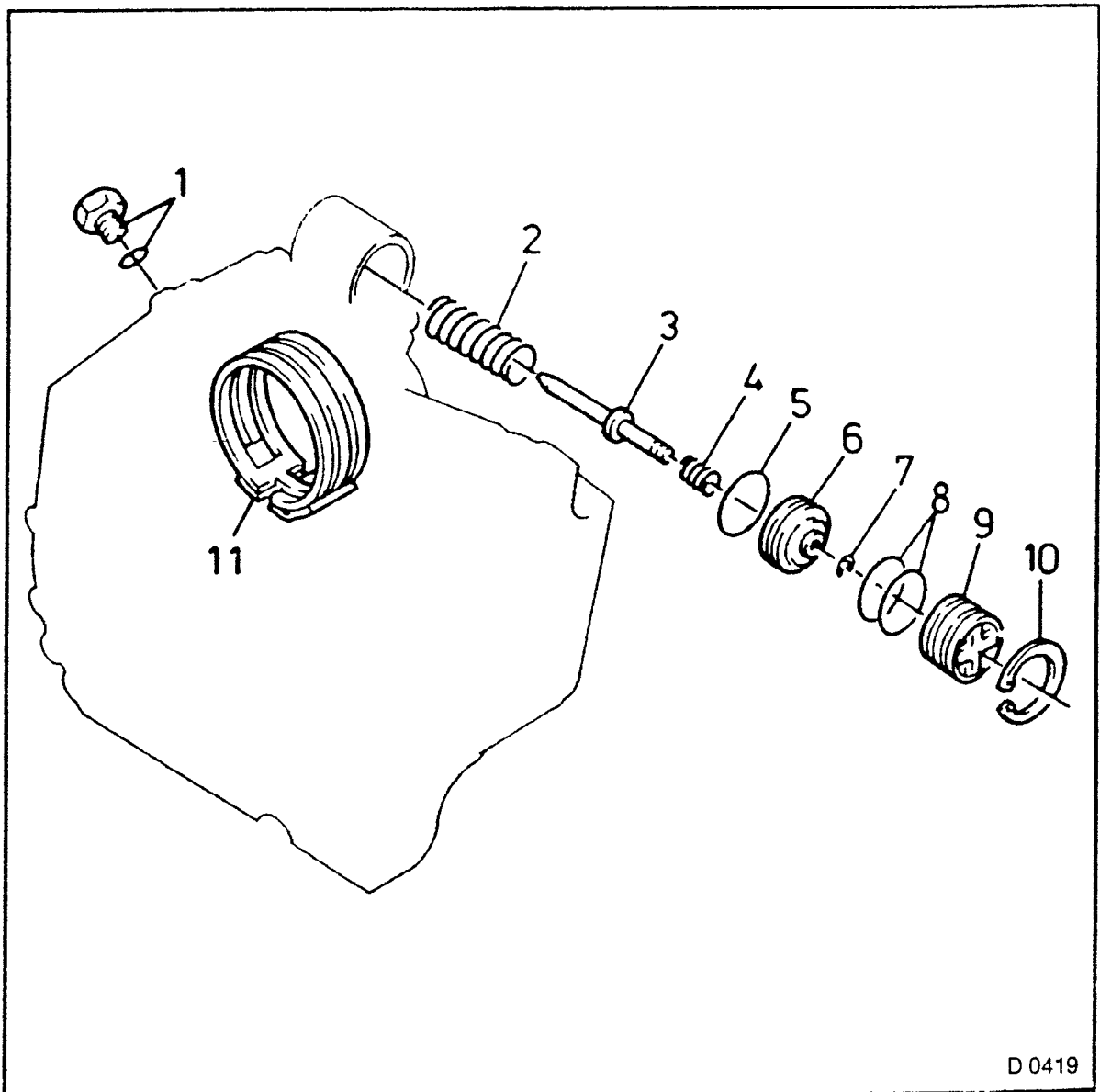


Fig. 396 — Reduction Brake.

- 1 = Anchor bolt with seal ring
- 2 = Pressure spring
- 3 = Piston rod
- 4 = Cushion spring
- 5 = Seal ring
- 6 = Piston
- 7 = Retainer ring
- 8 = Seal rings
- 9 = Cover
- 10 = Retaining ring
- 11 = Brake band B4

## Reduction Brake — Overhaul

### DISASSEMBLE

1. Reduction brake.
2. Piston for brake band B4 — see: “Assemblies, Remove from Transmission”, page 138.
3. Renew rubber O-seal rings (4) on piston (1) and cover.

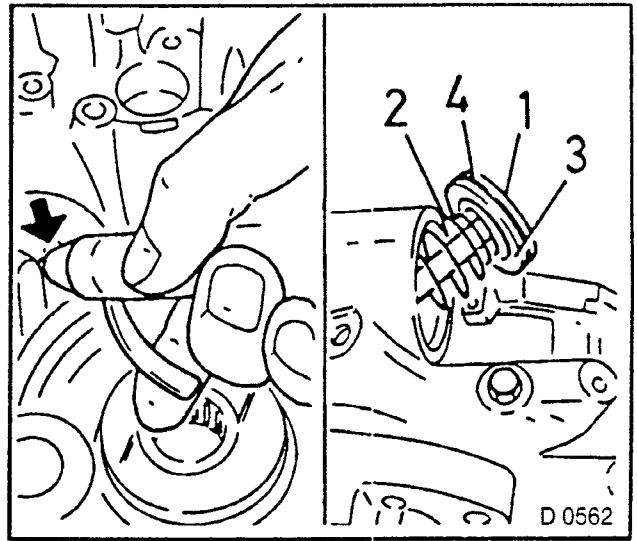


Fig 397

4. Piston rod for reduction brake
5. Remove retainer ring (1) from piston rod (2) using pliers, Pressure spring (3), Cushion spring (4), Washer (5), from piston rod.

### MEASURE

- 1 Free length and outer diameter of pressure spring (3).

Measurement values:

Length (6): 63.2 mm, outer diameter (7): 29.7 mm

Length of piston rod (2), measurement value: 70.5 mm.

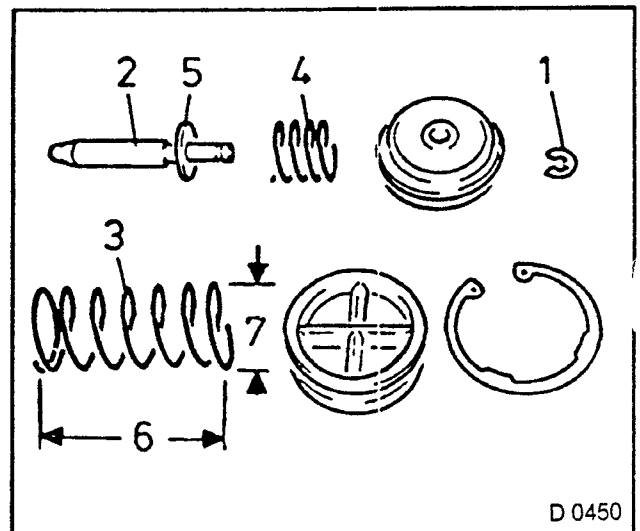


Fig 398

**ASSEMBLE**

1. Piston for brake band B4
2. Install piston rod.  
Washer.  
Pressure spring.  
Cushion spring on piston.  
Secure with new retainer ring.

**INSTALL, CONNECT**

1. Piston for brake band B4 in main housing  
Insert piston with pressure spring and cover in transmission.  
Compress and install retaining ring.

**INSPECT**

1. Correct seating of retaining ring in groove.

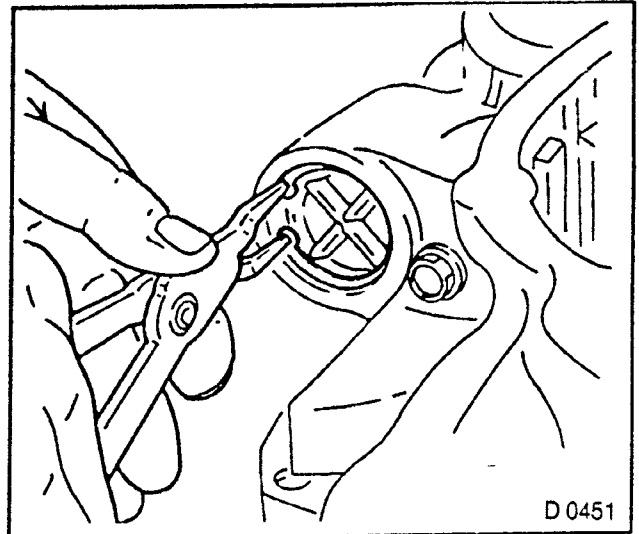


Fig. 399

**INSTALL, CONNECT**

1. Freewheel F3 (2) in main housing.
2. Insert retaining ring (1).

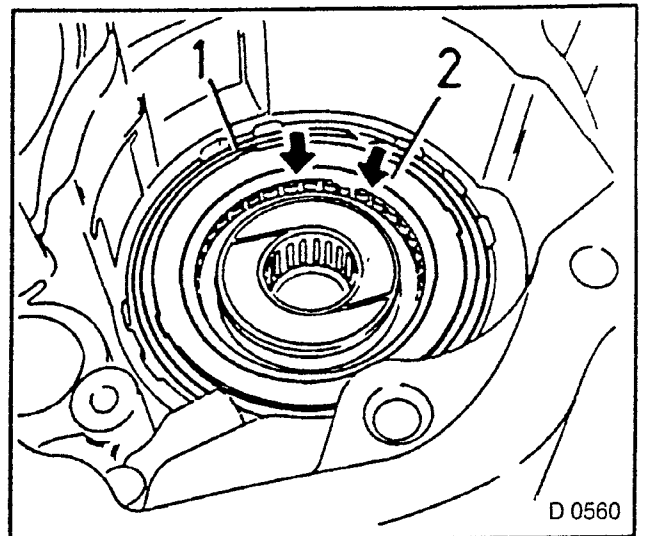


Fig. 400

3. Brake band B4, anchor bolt (1) — protrudes from outside through housing; piston rod must contact brake band actuation centrally (2).

**TIGHTEN (TORQUE)**

1. Anchor bolt to main housing — 170 Nm, note correct seating at brake band.

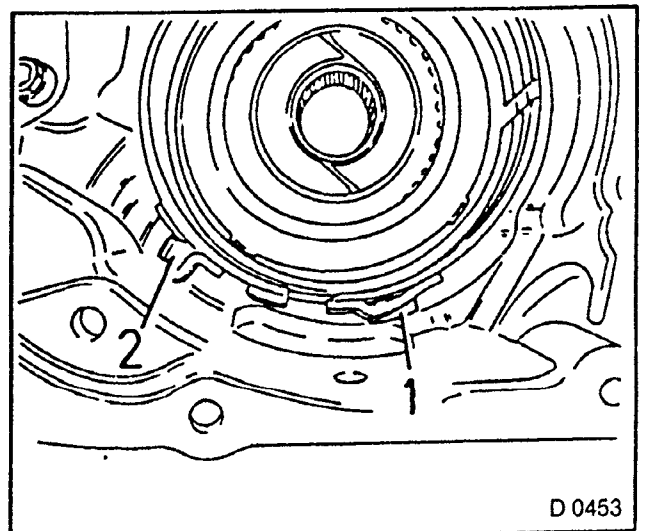
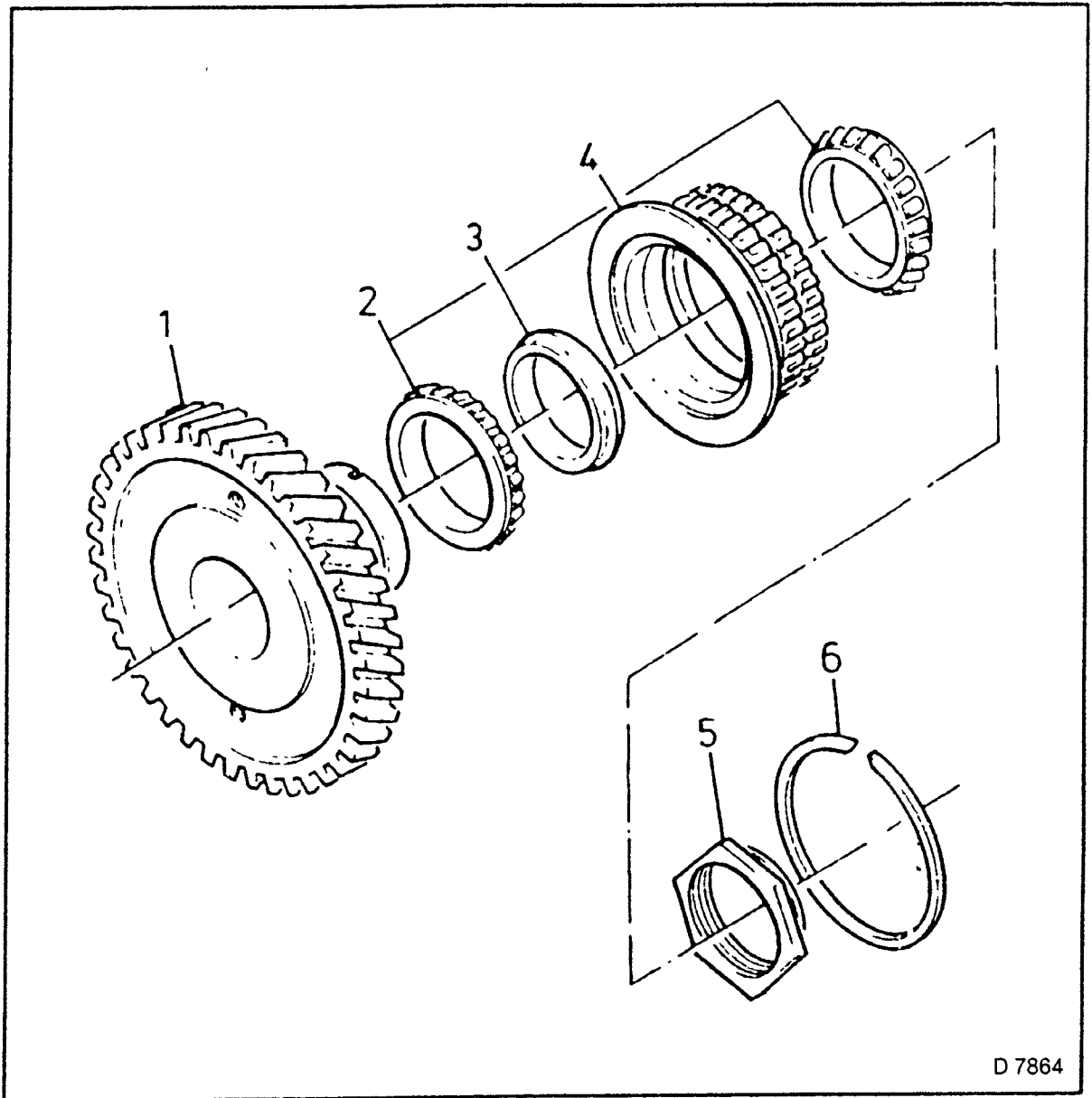


Fig. 401



D 7864

Fig. 402 — Intermediate Drive Gear

- 1 = Intermediate drive gear
- 2 = Bevel gear bearing
- 3 = Spacer
- 4 = Outer race
- 5 = Retaining nut
- 6 = Retaining ring

## Intermediate Drive Gear. — Check

### INSPECT

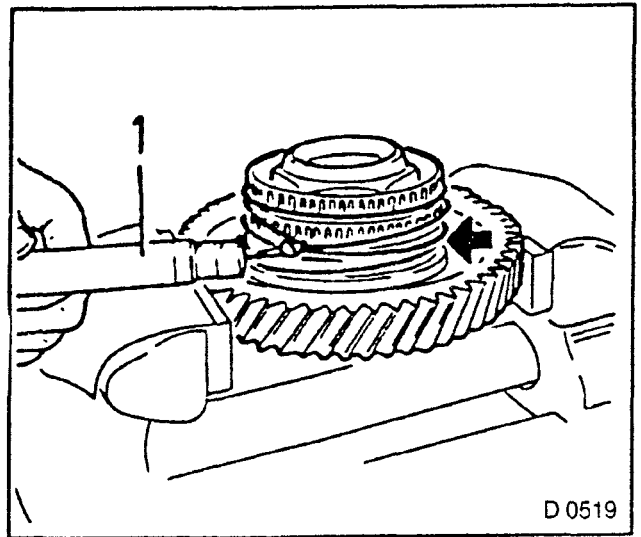
1. Splines of intermediate drive gear for damage and wear.  
If necessary, replace assembly, an overhaul of the intermediate drive gear is not anticipated.

In case no external damage is determined: --

### MEASURE

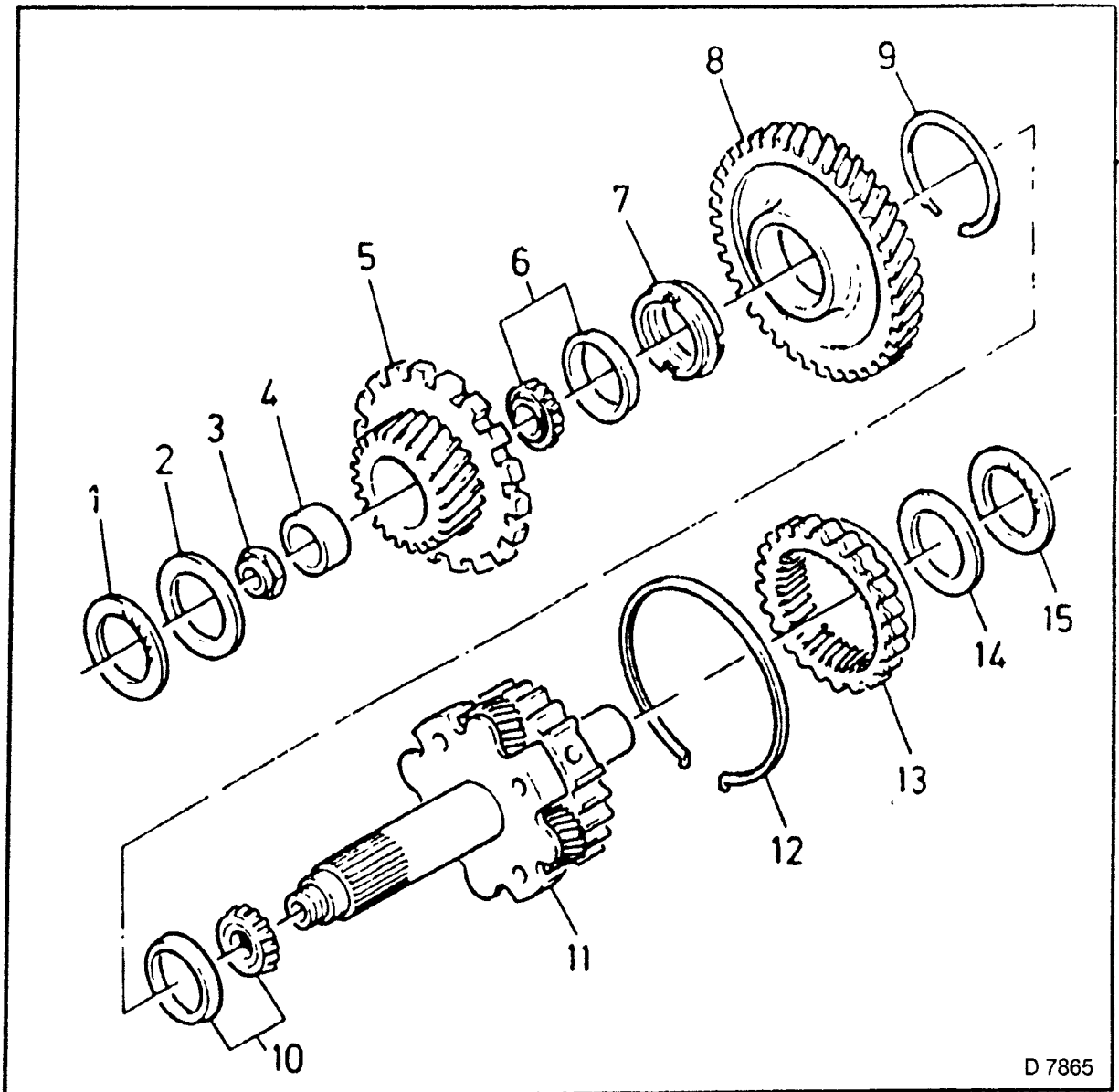
1. Pre-tension of intermediate drive gear.
2. Intermediate drive gear in vice — carefully clamp to splines.
3. Starting torque with spring tension gauge (1) — attach with cord at groove of outer race (arrow).

Measurement value: 30 to 80 Ncm, if necessary replace assembly.



D 0519

Fig 403



D 7865

Fig. 404 — Planetary Gear Set P2

- 1 = Thrust bearing
- 2 = Race assembly
- 3 = Fastening nut
- 4 = Inner race
- 5 = Drive gear (driving), parking lock wheel
- 6 = Bevel gear bearing
- 7 = Spacer
- 8 = Driven intermediate gear
- 9 = Retaining ring
- 10 = Bevel gear bearing
- 11 = Planetary carrier
- 12 = Retaining ring
- 13 = Internal gear
- 14 = Race assembly
- 15 = Thrust bearing

## Planetary Gear Set P2 — Overhaul

### INSPECT

1. Splines of planetary gear set P2 for damage and wear. If necessary, replace assembly.

An overhaul is only provided for the planetary gear set mount.

### MEASURE

1. Pre-tension of planetary gear set P2 — KM-703 (1, on new transmissions with hexagon spanner, size 36) and MKM-536 (2).
2. Assembly in vice — KM-696.
3. Using upper locking bolt (3), secure against turning.
4. Locking bolt threads (3) lie against side of recess (detail) — **DO NOT** tighten so that it locks the planetary gear set (as the component could no longer be turned).
5. Carry out several measurements and take average.

Starting torque: 0.55 to 1.35 Nm.

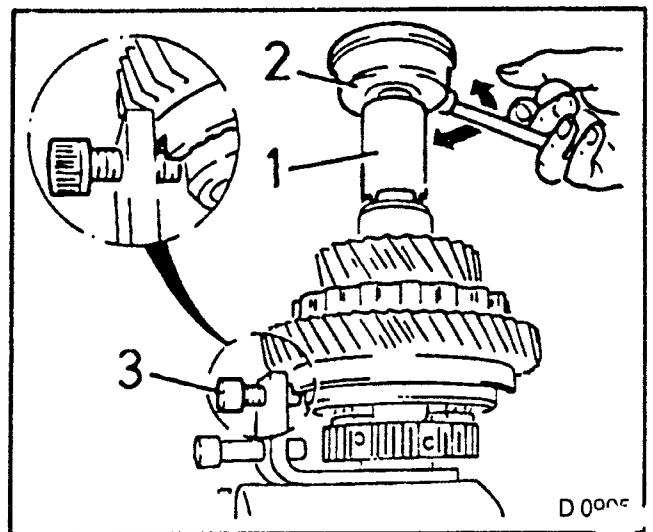


Fig. 405

### DISASSEMBLE

1. Planetary gear set and drive gear.
2. Position component with fastening nut downwards in vice.
3. Tension retaining ring (1) in recess of driven intermediate gear (2) using ring pliers.
4. Guide out of groove and remove internal gear upwards.

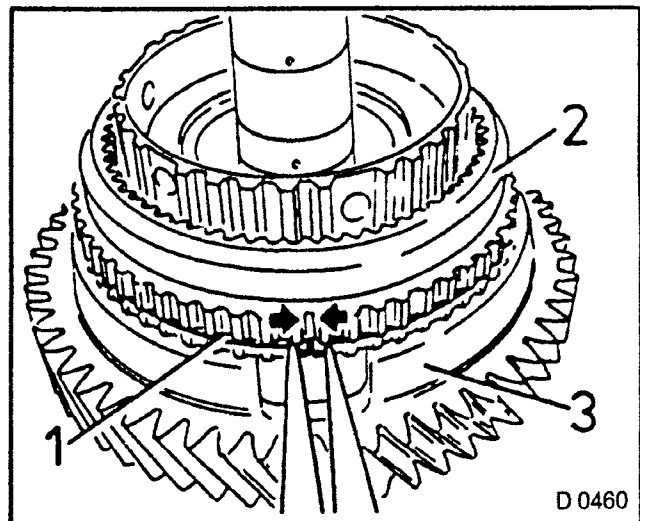


Fig. 406

**INSPECT**

1. Splines of internal gear and planetary gears for damage and wear.

If necessary replace planetary gear set P2.

In case no damage is visible:

**MEASURE**

1. Play (1) between planetary gears and planetary carrier — with feeler gauge. Measurement value: 0.20 to 0.60 mm. If necessary, replace planetary gear set P2.

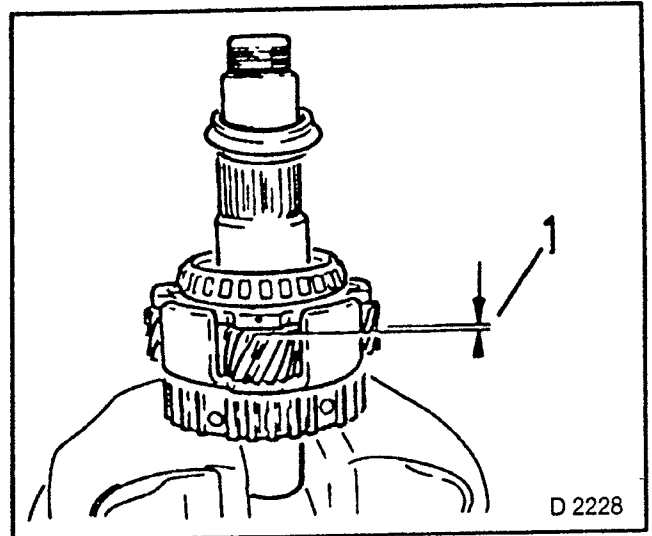


Fig. 407

Overhaul bearings (only necessary if starting torque is not correct):

**DISASSEMBLE**

1. Planetary gear set P2.
2. Loosen two caulkers at the fastening nut with a chisel.
3. Fastening nut from planetary carrier — KM-703 (1, on new transmissions with hexagon spanner, size 36).
4. Thrust bearing and race assembly remain installed, if necessary stick with grease.
5. Drive gear in vice — KM-696 (2), secure against turning with lower locking bolt (3) at bore hole in planetary carrier.

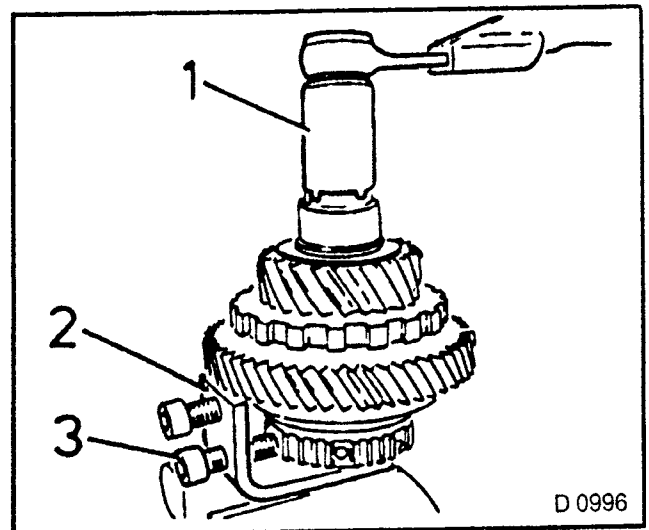


Fig 408

**NOTE:**

**RELEASE TORQUE VERY HIGH.**

**REMOVE, DISCONNECT**

1. Drive gear (1) and inner race from planetary carrier (2).
2. Plate from KM-701 (3) between parking lock wheel and driven intermediate gear.
3. Press out from under a clamp using KM-407-A (4).

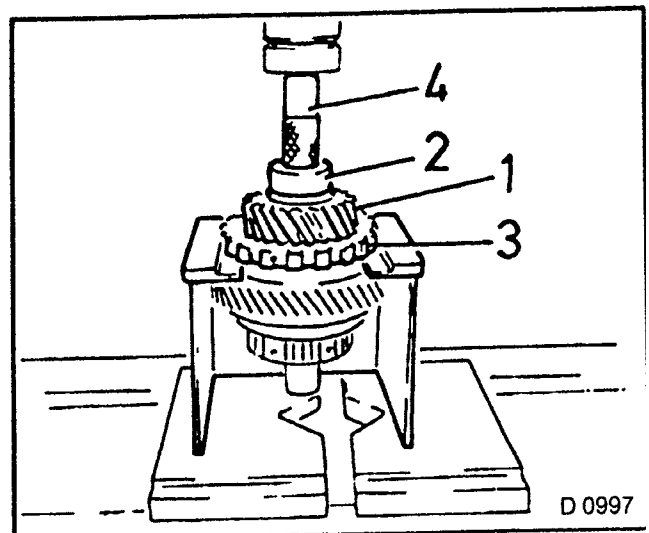


Fig. 409



**REMOVE, DISCONNECT**

- 1 Press off driven intermediate gear (1) and front bevel gear bearing (2).
- 2 Planetary gear set points downwards, **SUPPORT** intermediate gear (1), **DO NOT** damage thread (3).

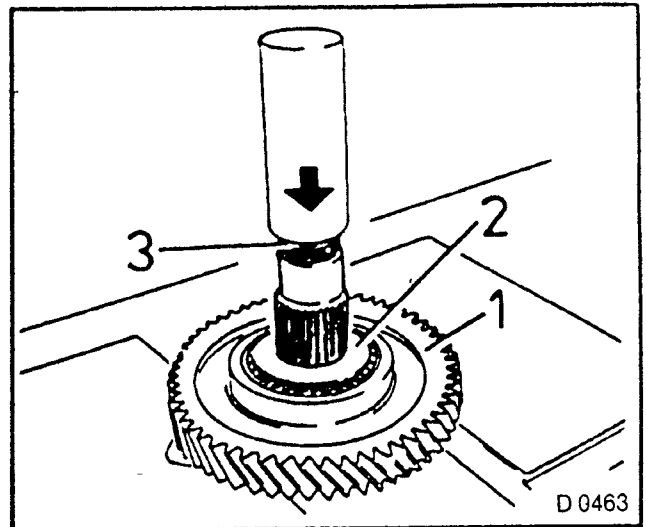


Fig 410

3. Spacer from planetary carrier
4. Rear bevel gear bearing — with KM-171 (1, in vice).
5. Remove KM-528 (2). Use KM-407-A (3) and thrust plate from KM-171.

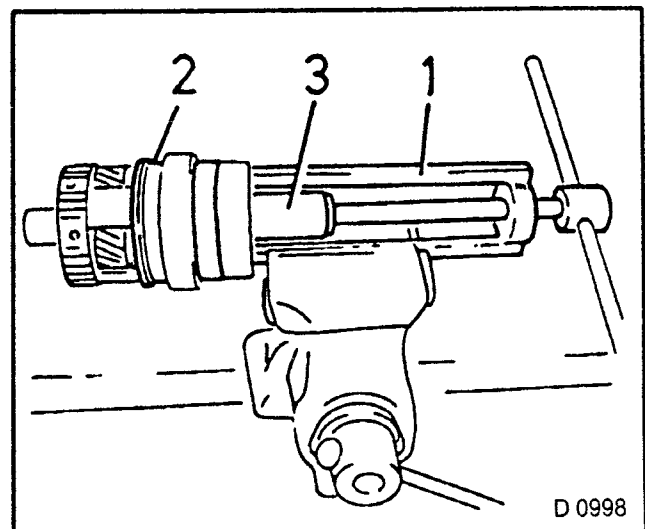


Fig. 411

**REMOVE, DISCONNECT**

1. Two bearing outer races (1) from intermediate gear.
2. Drive out using suitable drift. **DO NOT** damage seating surface.
3. Retaining ring (2).

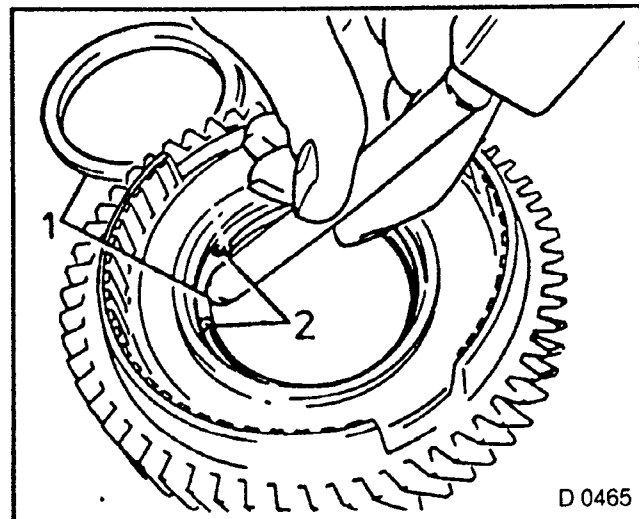


Fig. 412

**ASSEMBLE**

1. Planetary gear set P2.
2. Insert retaining ring in groove of intermediate gear.
3. Press in two new bearing outer races until they rest against retaining ring — KM-695 (1) and KM-305 (2).

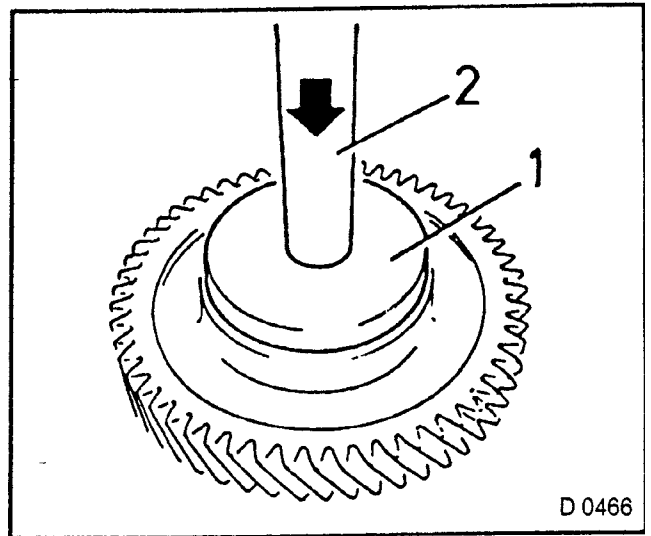


Fig. 413

**INSTALL, CONNECT**

1. New rear bevel gear bearing (1) — drive on with KM-697 (2).
2. Place new spacer on roller bearing.

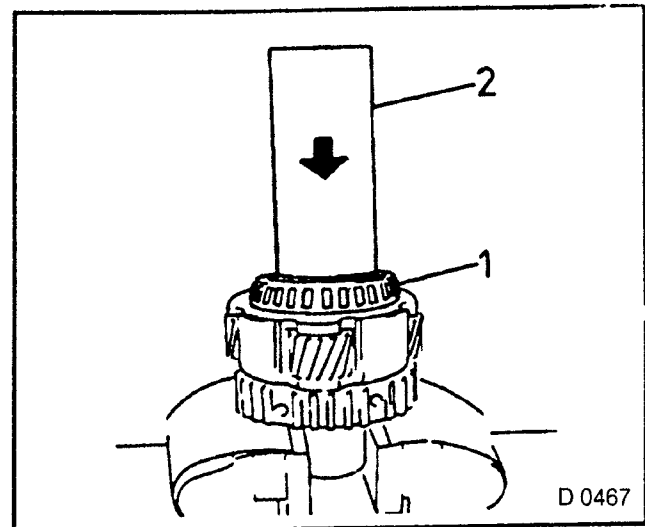


Fig. 414

3. Driven intermediate gear (1).
4. New front bevel gear bearing (2). Press on with KM-697 (3) until resting on spacer.

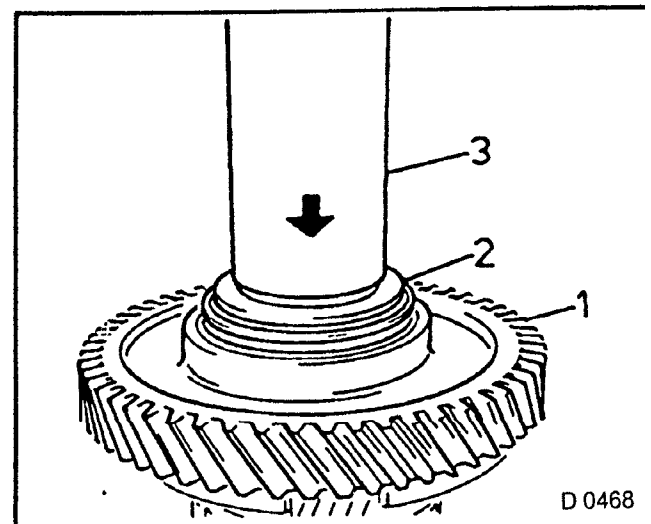


Fig. 415

**INSTALL, CONNECT**

1. Press in drive gear (driving, 1) with KM-697 (2).

**CAUTION**

**PRESS IN ONLY UNTIL THE DRIVEN INTERMEDIATE GEAR CAN STILL BE TURNED SLIGHTLY, CHECK WHILE PRESSING (ARROW).**

**INSTALL, CONNECT**

- 1 Press in bevel gear bearing inner race with KM-697 until seated against drive gear.

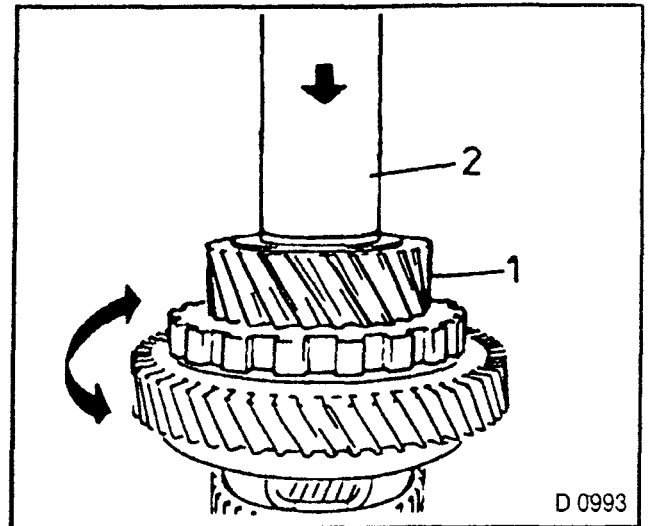


Fig 416

2. Pre-tighten new fastening nut and loosen again (for placing bearing) — KM-703 (1, on new transmissions with hexagon spanner, size 36).
3. Drive gear assembly in vice — KM-696 (2), secure against turning with locking bolt (3).

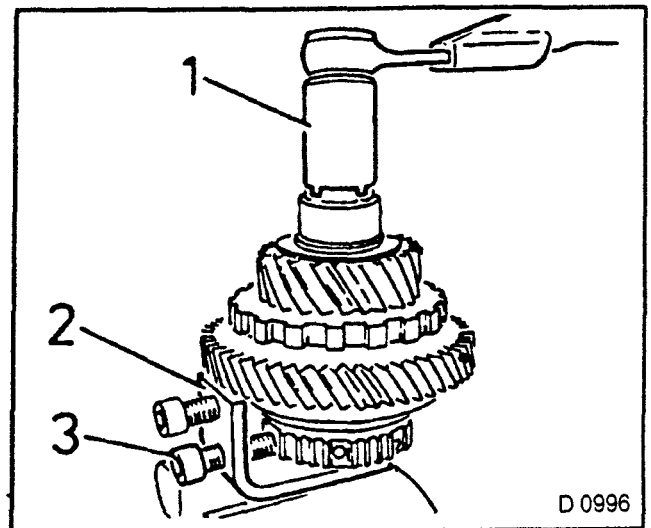


Fig. 417

**ADJUST**

1. Measure pre-tension of planetary gear set P2 — KM-703 (1, on new transmissions with hexagon spanner, size 36) and MKM-536 (2).
- 2 Assembly in vice — KM-696.
3. Using upper locking bolt (3), secure against turning.
4. Locking bolt threads (3) lie against side of recess (detail), **DO NOT** tighten so that it locks the planetary gear set.
5. Before measurement, spin on both sides (placing of bearings).
6. Tighten fastening nut until starting torque is 0.55 to 1.35 Nm, carry out several measurements and take average.
7. Secure fastening nut at two points by caulking.

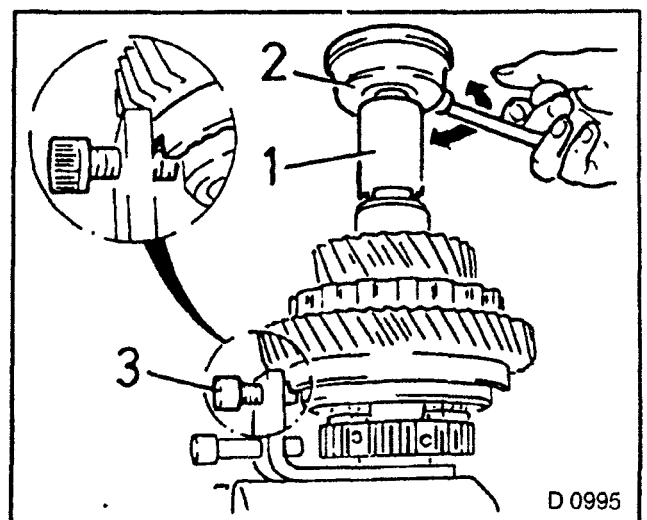


Fig. 418

**ASSEMBLE**

1. Planetary gear set and drive gear (driving).
2. Position component with fastening nut downwards in vice.
3. Thread internal gear (2) into planetary gear set.
4. Align hooks of retaining ring (1) with recess of intermediate gear (3).
5. Tension retaining ring.
6. Insert internal gear.
7. Snap retaining ring in groove of intermediate drive gear.

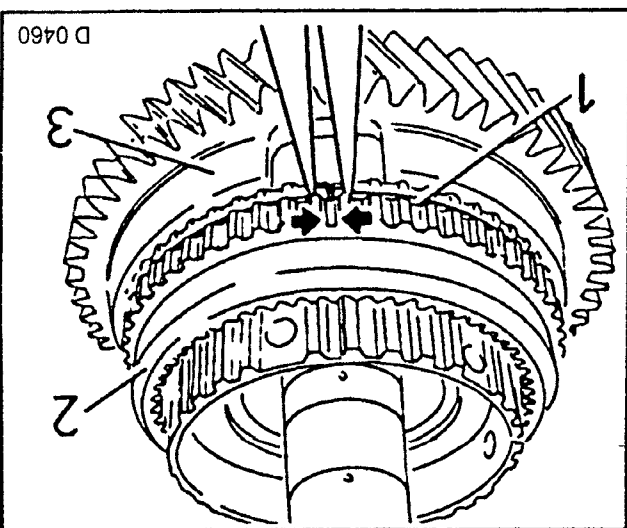
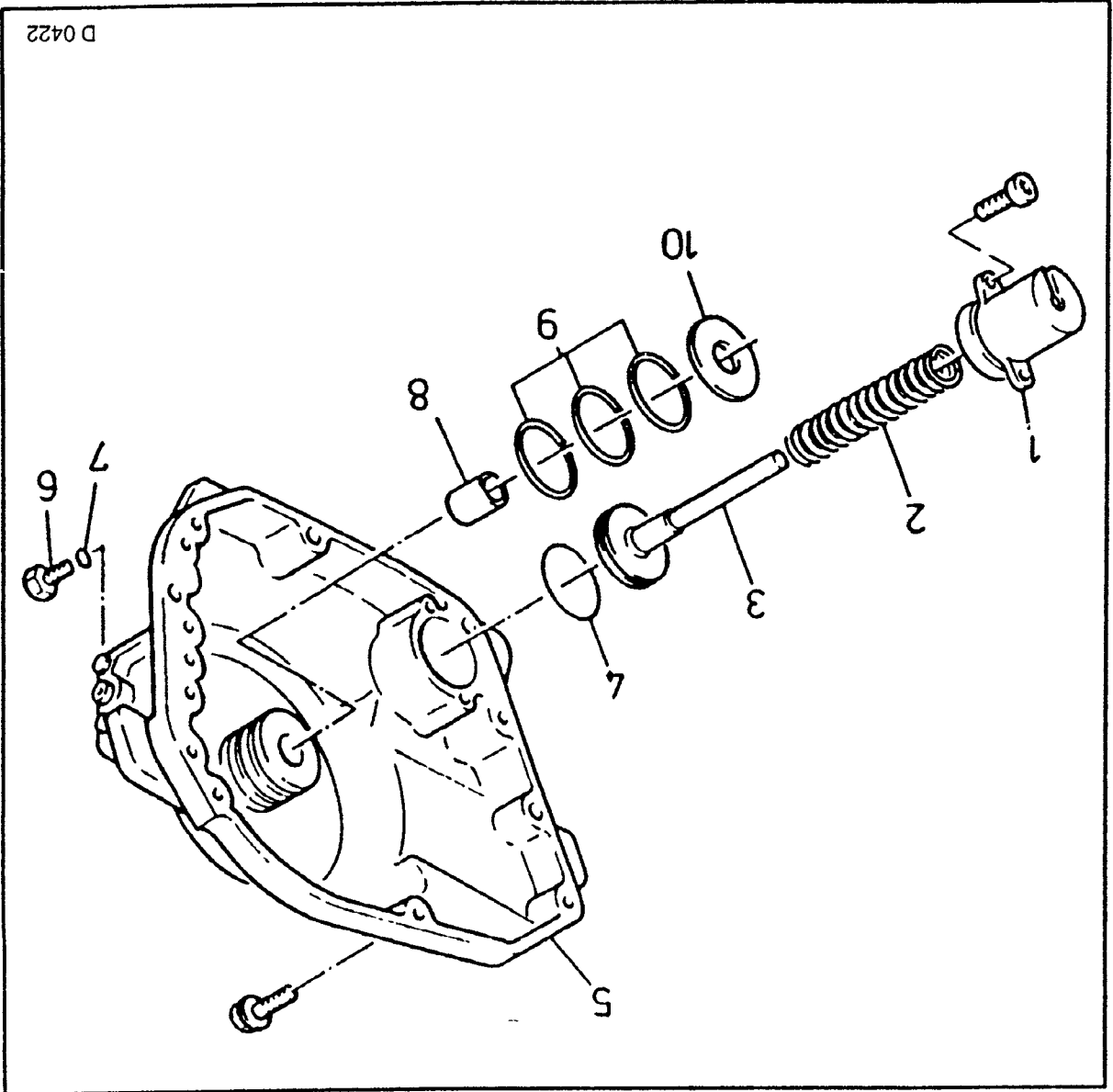


Fig. 419

D 0460



D 0422

Fig. 420 — Rear Cover with Piston C1

- 1 = Cover for piston C1
- 2 = Spring
- 3 = Piston C1
- 4 = Seal ring
- 5 = Rear cover
- 6 = Plug, M 8
- 7 = Seal ring
- 8 = Needle bearing
- 9 = Hook seal rings
- 10 = Race

## Rear Cover with Piston C1 — Overhaul

### DISASSEMBLE

1. Rear cover.
2. Thrust bearing (1).
3. Three hook seal rings from bearing journal (2) — ring ends are L-shaped. Press in one ring end in groove, hook out the other.
4. Cover for piston C1 (3).
5. Spring and piston C1 (Fig. 422, Item 3) — Renew rubber O-seal rings on piston (Fig. 422, Item 1)

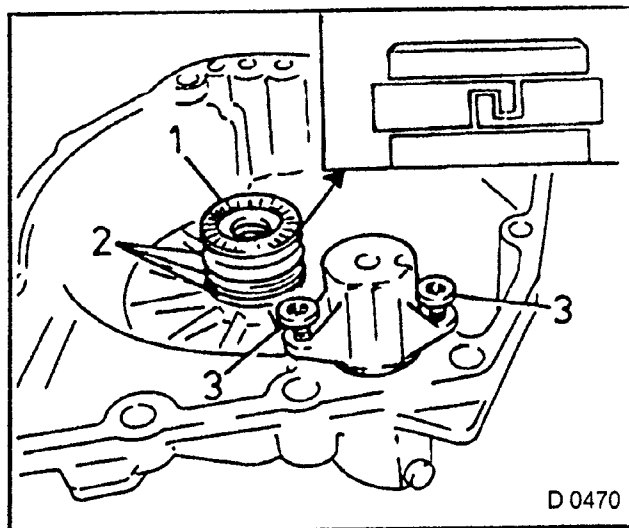


Fig 421

### MEASURE

- 1 Length (4) and outer diameter (5) of spring C1.  
Measurement values: Length (4) 78.1 mm, outer diameter (5) 20.7 mm.

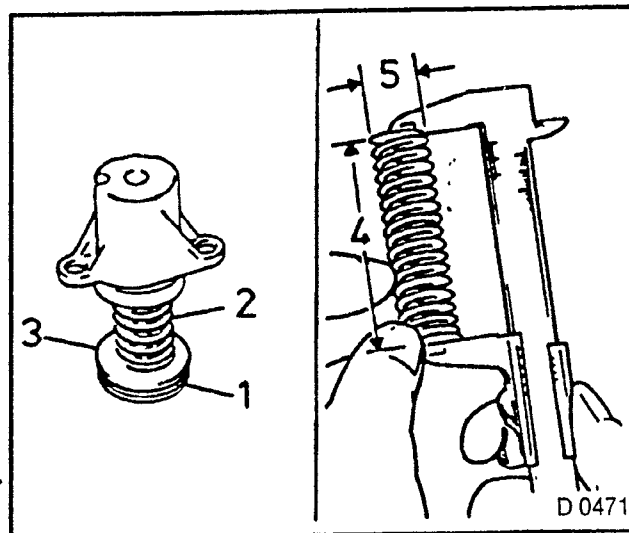


Fig. 422

### REMOVE, DISCONNECT

1. Needle bearing from journal in rear cover
2. Pull out with MKM-691 (1) and KM-556-1 (2).  
If necessary (arms of KM-556-1 too short), place KM-502-A under the arms of KM-556-1.

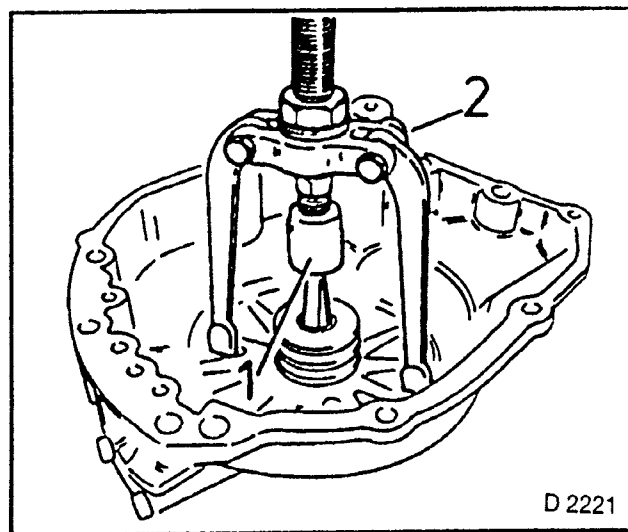


Fig 423

**INSTALL, CONNECT**

1. Needle bearing in journal.
2. Drive in with KM-711-2 (1) until tool stops at journal (2).

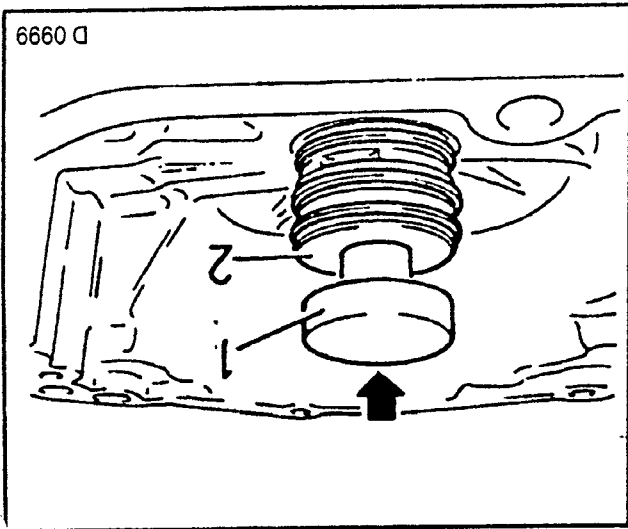


Fig. 424

**ASSEMBLE**

1. Rear cover.
2. Piston C1, spring and cover.

**TIGHTEN (TORQUE)**

1. Cover C1 to rear cover — 10 Nm.

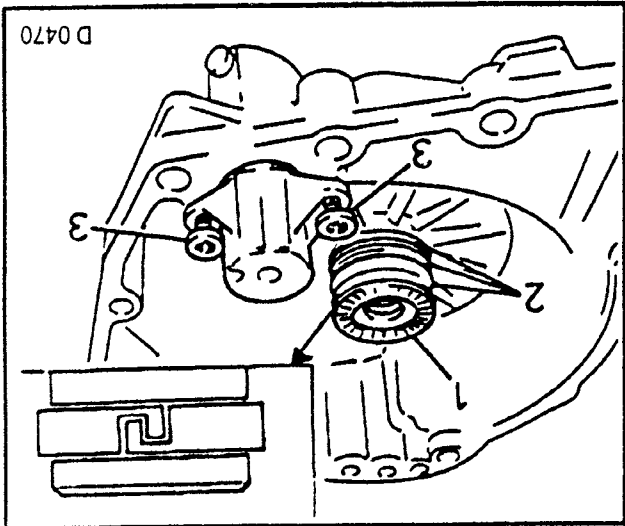


Fig 425

**INSTALL, CONNECT**

1. Three hook seal rings on bearing journal — ring ends are L-shaped. Hook out as described for removal, **DO NOT** expand more than necessary.

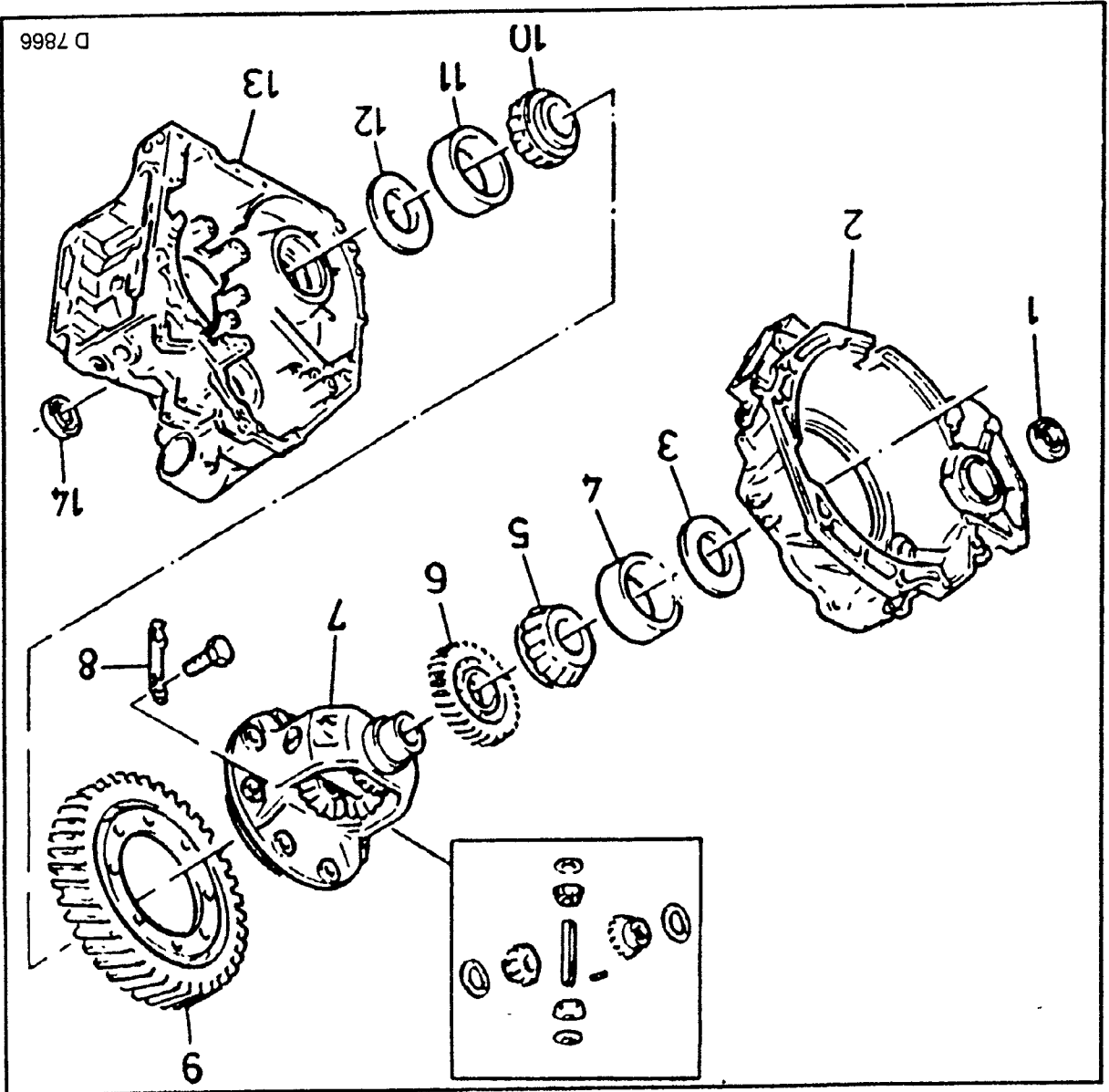


Fig 426 — Differential

- 1 = Axle shaft seal ring.
- 2 = Auxiliary housing.
- 3 = Friction washer (auxiliary housing).
- 4 = Bevel gear bearing outer race
- 5 = Bevel gear bearing inner race
- 6 = Speedometer gear (driving).
- 7 = Differential.
- 8 = Locking plate.
- 9 = Drive gear (driven).
- 10 = Bevel gear bearing inner race.
- 11 = Bevel gear bearing outer race.
- 12 = Friction washer (main housing).
- 13 = Main housing.
- 14 = Axle shaft seal ring.

D 7866



## Differential — Overhaul

### DISASSEMBLE

1. Differential.
2. Both bevel gear bearing inner races (1) — KM-161-A (2).  
Hooks KM-161-3 (3) and Thrust Plate KM-403 (4).  
If necessary unscrew remover hooks from counter and install individually on bearing.
3. Remove speedometer helical gear (driving, 5).

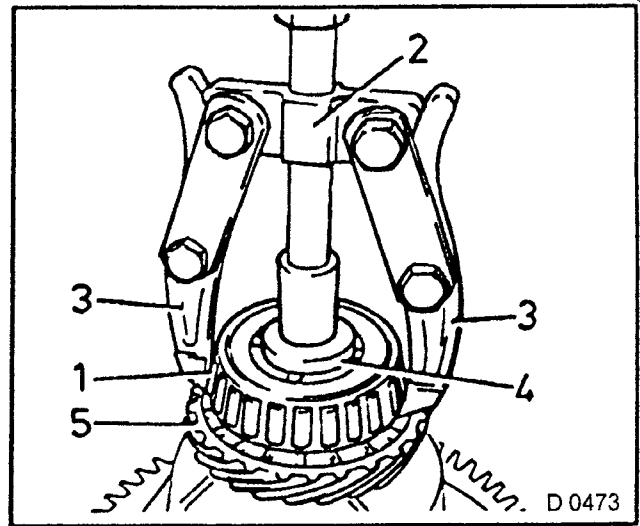


Fig. 427

- 4 Drive gear (driven).
5. Mark position of drive gear relative to differential housing.
6. Release locking plates.
7. Remove eight bolts and remove locking plates.
8. Loosen drive gear, if necessary with plastic hammer.

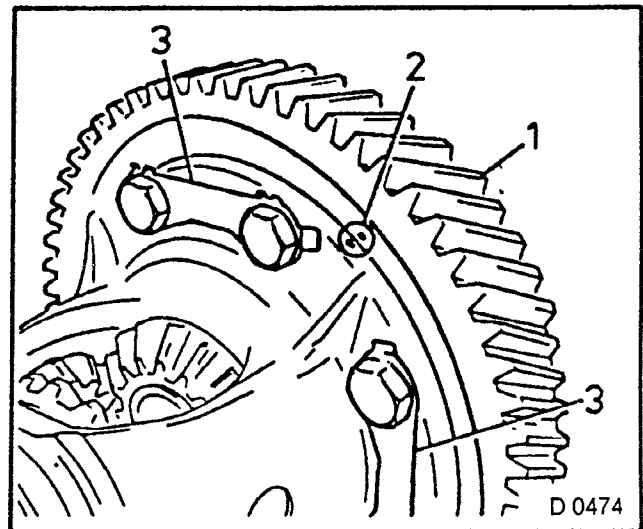


Fig. 428

### REMOVE, DISCONNECT

1. Parallel pin (1) with drift, bevel gear axle (2).  
Remove differential gears with friction washers (3) through installation aperture by turning at one of the two axle shaft gears.
2. Axle shaft gears with friction washers (4).

### INSPECT

1. Inner parts of differential for damage and wear. If necessary, replace assembly — reuse drive gear (driven).

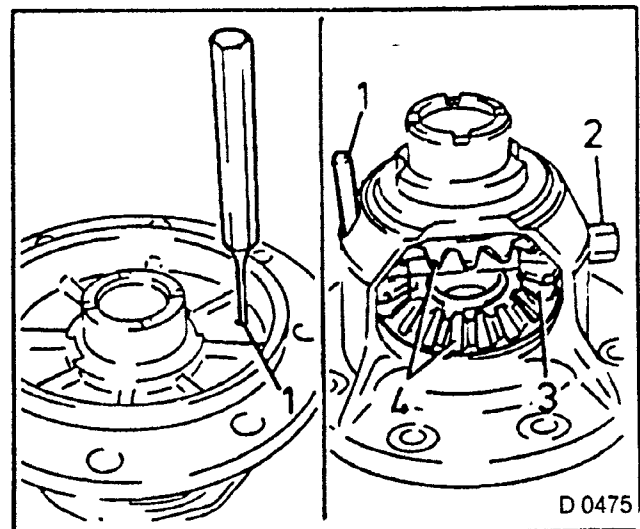


Fig. 429

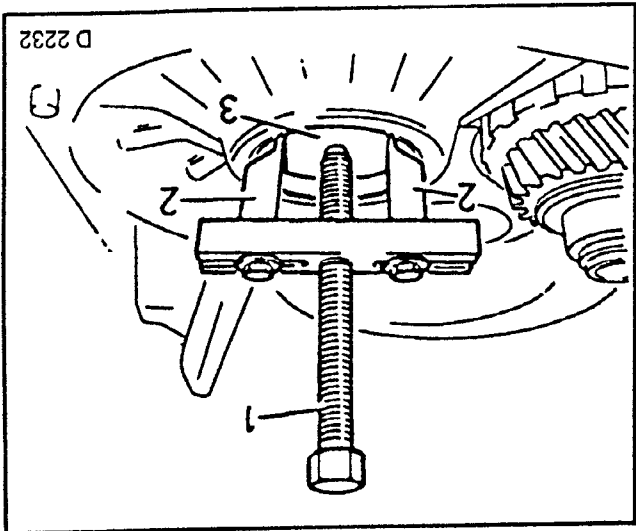
**NOTE:**  
 Before removing (tool inserted as described above and slightly pretensioned), heat housing to approximately 80°C/176°F with hot air blower.

2. Drive both axle shaft seal rings out of main or auxiliary housing from inside outwards (if not yet removed)
3. Remove both bevel gear bearing outer races together with friction washers — KM-210-A (1), KM-709 (2 and 3). Remove hooks grip in recess under friction washer.

**ASSEMBLE**

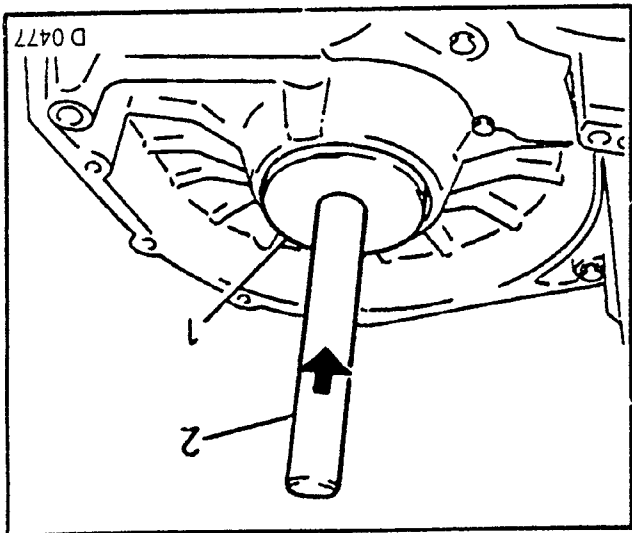
1. Differential.
2. Press in both bevel gear bearing outer races with friction washers — KM-695 or KM-710 (1) and KM-305 (2). Friction washer thickness for bearing in auxiliary housing: 2,5 mm. With new bearings for outer race in main housing, use smallest washer thickness.

Fig. 430



D 2232

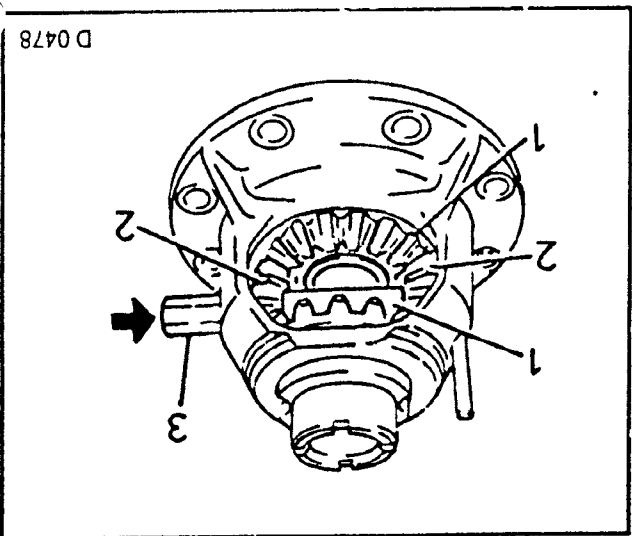
Fig. 431



D 0477

- If no damage of inner parts is determined.
3. Axle shaft gears with friction washers (1) in differential
  4. Align differential gears (2) and friction washers with bore for bevel gear axle by turning at one of the axle shaft gears.
  5. Bevel gear axle (3) in differential housing.
  6. Drive parallel pin in bevel gear axle and secure by centre punch at edge of bore.

Fig. 432



D 0478

**INSTALL, CONNECT**

1. Drive gear (driven) on differential housing.
2. Heat drive gear (driven) to approximately 100°C/212°F in fluid (thermocolor pencils or suitable temperature gauge).
3. Drive gear to differential housing. Observe markings.

**TIGHTEN (TORQUE)**

1. Drive gear (driven 1) — 100 Nm. Use new bolts and locking plates (3). Secure bolts.

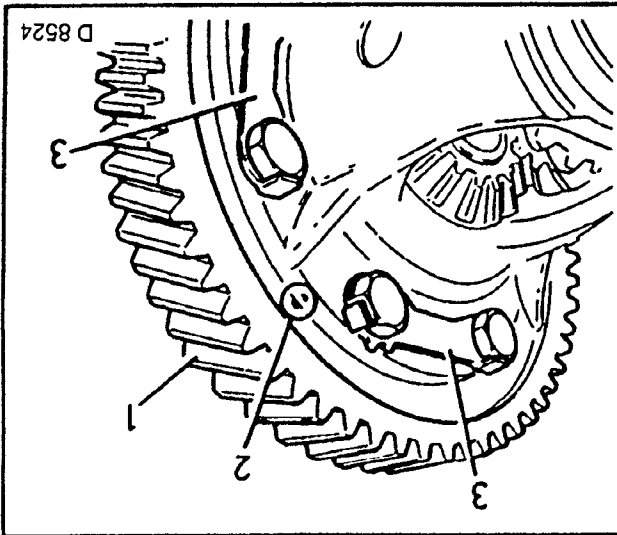


Fig. 433

**INSTALL, CONNECT**

1. Speedometer gear (driving, 1) — note retaining lug.
2. Press on both bevel gear bearing inner races (2 and 3) — KM-697 (4)

**NOTE:**

**INSTALL WITH SMALL OUTER DIAMETER OF BEARING (2) ON SPEEDOMETER GEAR SIDE.**

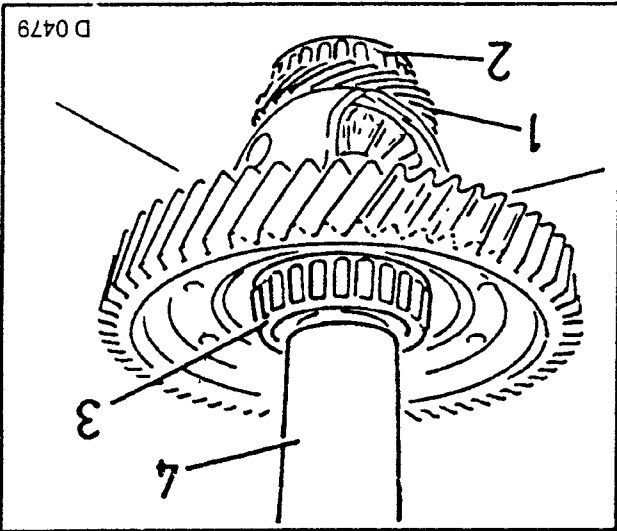


Fig. 434

**ADJUST**

1. Pre-tension of differential bevel gear bearing.
2. Place differential in main housing.

**TIGHTEN (TORQUE)**

1. Auxiliary housing to main housing — 30 Nm. Eleven bolts.

Note centering pin (arrow).

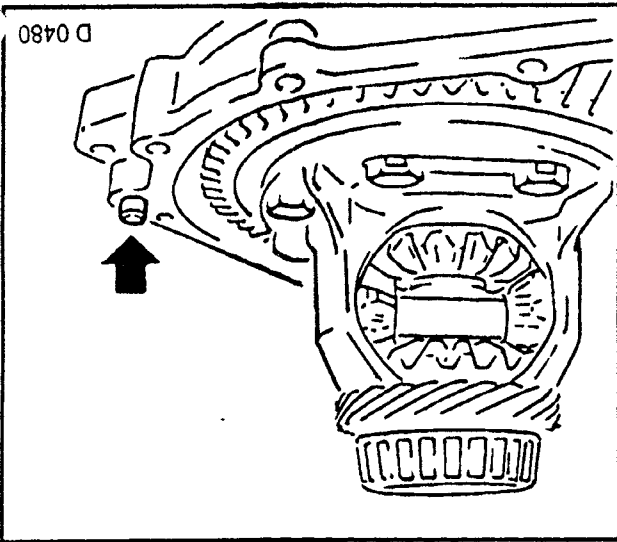


Fig. 435

**MEASURE**

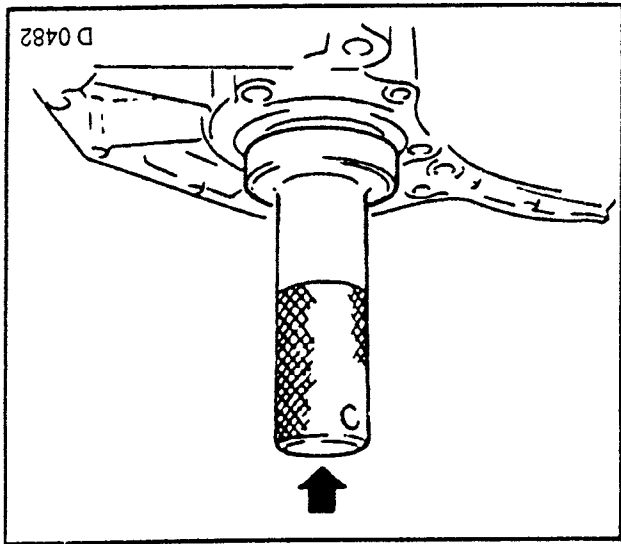
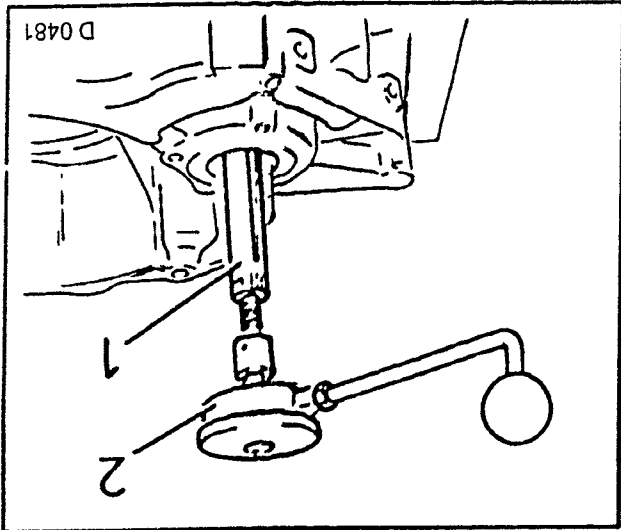
1. Starting torque of differential.
- Without gear set, with KM-J-28544-A (1, see also section "Special Service Tools") and MKM-536 (2).
- Measurement value:  
New bearing: 0,7 to 1,2 Nm.  
Used bearing: 0,35 to 0,6 Nm.
2. Correct by selecting suitable friction washers under bevel gear bearing outer race of main housing.

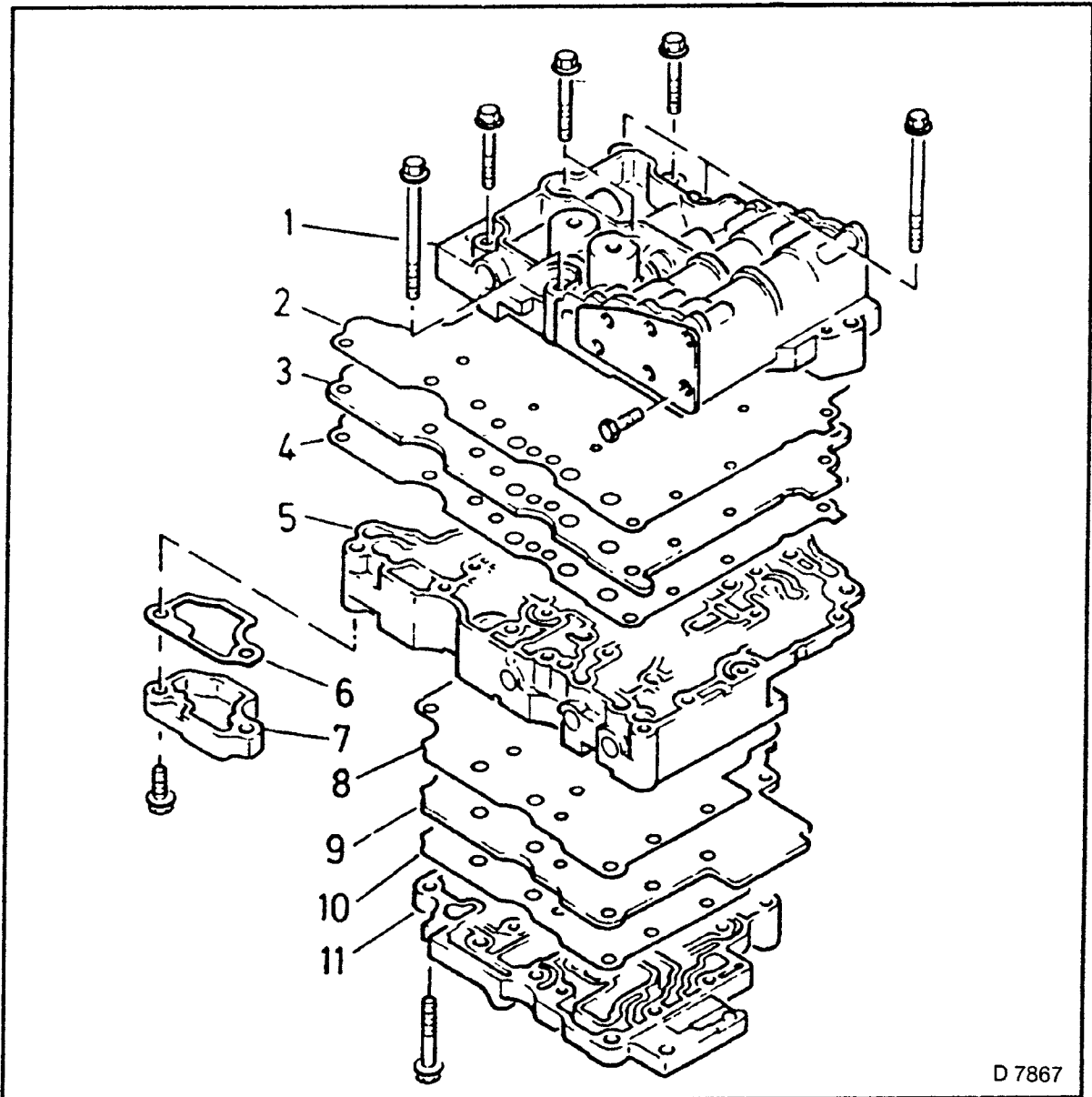
**REMOVE, DISCONNECT**

1. Auxiliary housing.
2. Differential.  
If necessary bevel gear bearing outer race of main housing (only if adjustment is necessary)

**INSTALL, CONNECT**

1. After adjustment of pre-tension:  
Axle shaft seal rings with KM-519.

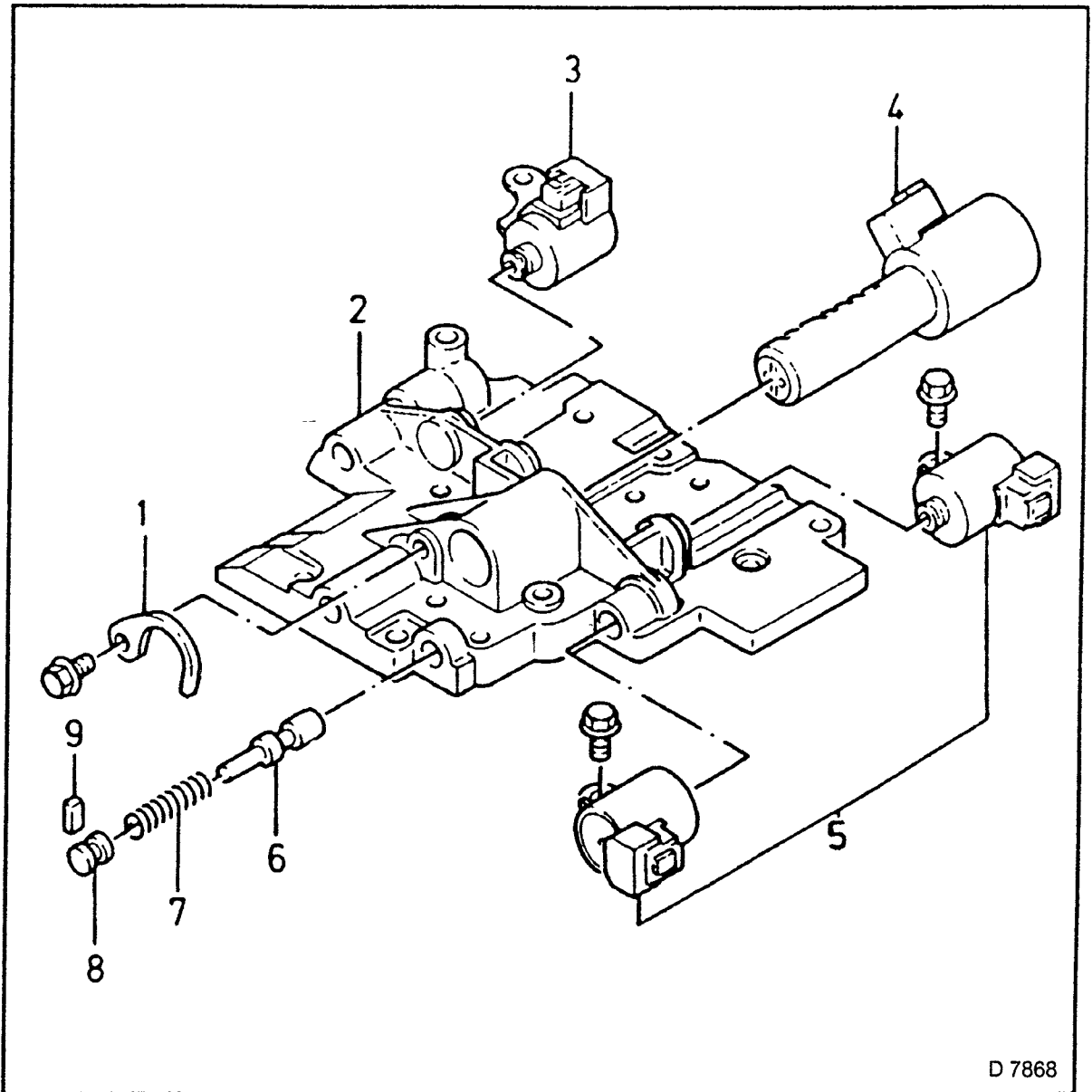




D 7867

Fig. 438 — Valve Body Assembly.

- 1 = Rear valve body
- 2 = Rear valve body gasket
- 3 = Centre valve body plate
- 4 = Centre valve body gasket
- 5 = Centre valve body
- 6 = Intake cover gasket
- 7 = Intake cover
- 8 = Centre valve body gasket
- 9 = Front valve body plate
- 10 = Front valve body gasket
- 11 = Front valve body



D 7868

Fig. 439 — Front Valve Body

- 1 = Fluid pressure regulator terminal
- 2 = Front valve body
- 3 = Solenoid valve
- 4 = Fluid pressure regulator
- 5 = Solenoid valve
- 6 = Modulator valve
- 7 = Modulator valve pressure spring
- 8 = Modulator valve plug
- 9 = Modulator valve wedge

## Valve Body — Overhaul

### NOTE:

Valve body is disassembled only for checking and cleaning purposes, an exchange of inner parts is not provided for. Do not damage the inner parts, in particular the piston seal rings and springs.

Set aside removed parts as installed to avoid confusion. If damage is determined during checking, replace the complete valve body.

### REMOVE, DISCONNECT

1. Two cable retainers (1).
2. Three solenoid valves (2).  
Renew rubber O-seal rings.
3. Fluid pressure regulator (3) — remove bolt and retaining clip.

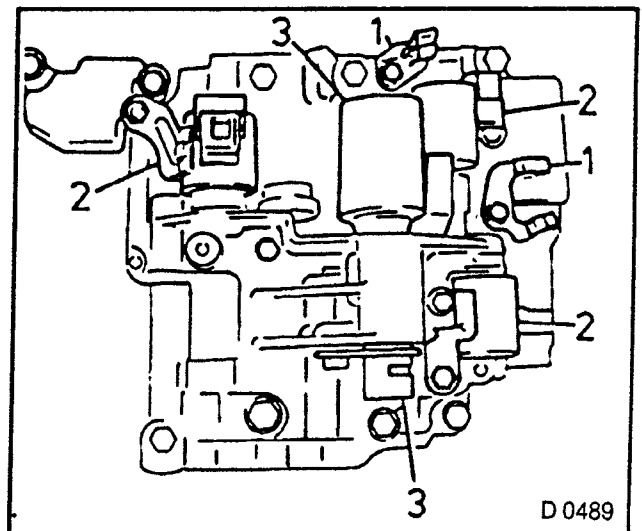


Fig. 440

### Remove — Disconnect

1. Front from centre valve body.
2. Two bolts from rear valve body (1), turn valve body.
3. Five bolts from front valve body (2).

### NOTE:

1. Set aside front valve body on its top side.
2. Separate centre and rear valve bodies together with plate and gaskets from front valve body by moving sideways, so that the lock balls remain in their ducts.
3. Set aside assembly on lower valve body. Remove plate and gaskets by moving sideways and set aside as installed.

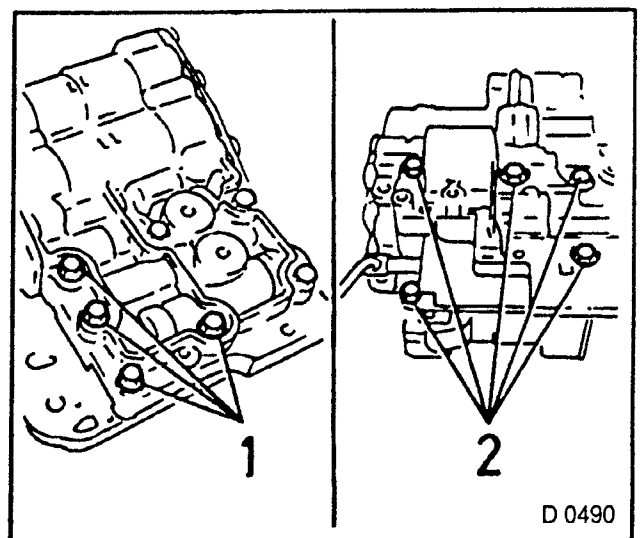


Fig. 441

**INSPECT**

1. Function of solenoid valves (three pieces).
2. Measure electrical resistance between terminal (1) and housing (2) — with ohmmeter.  
Measurement value. 10 to 16 ohms.
3. Battery voltage (12 V) to solenoid valve — positive pole at terminal (1), negative pole at housing (2), Valve must switch audibly.

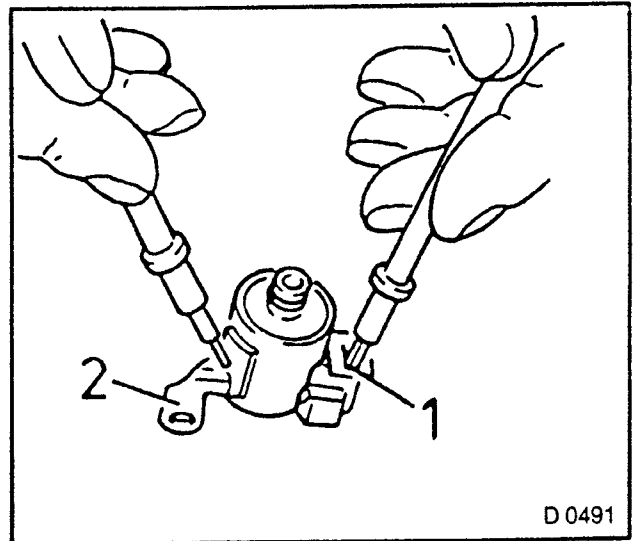


Fig 442

4. Function of fluid pressure regulator.
5. Measure electrical resistance between both terminals — with ohmmeter.  
Measurement value: 3.2 to 3.9 ohms (at room temperature — approximately 20°C/68°F).

**NOTE:**  
**THE PRESSURE REGULATOR IS NOT AVAILABLE AS A SINGLE PART AND IF DEFECTIVE MUST BE REPLACED TOGETHER WITH THE VALVE BODY.**

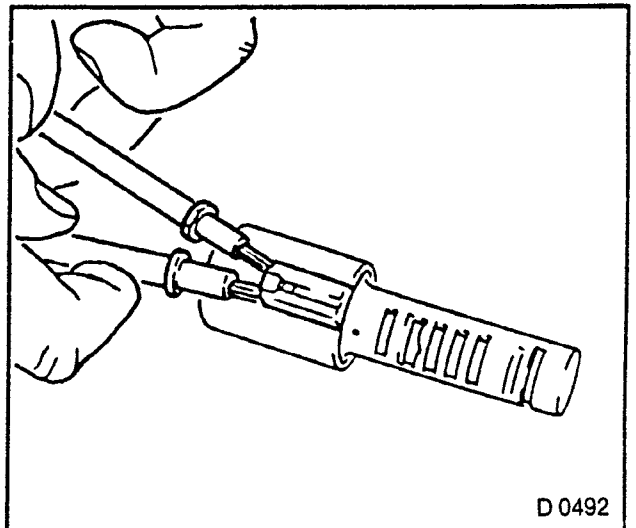


Fig 443

**REMOVE — DISCONNECT**

1. Centre from lower valve body — Three bolts (1).

**NOTE:**

1. Turn assembly.
2. Remove centre valve body together with plate and gaskets (2) from lower valve body by moving sideways.
3. Set aside with gasket down

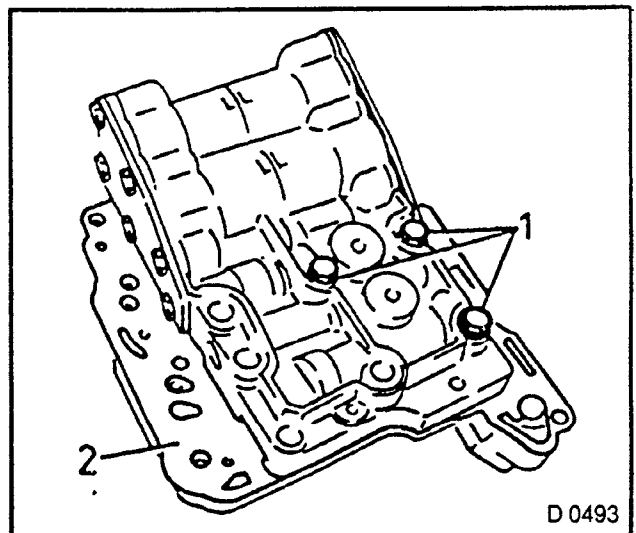


Fig. 444



**DISASSEMBLE**

1. Front valve body.
2. Modulator valve — remove wedge with magnetic lifter (1); Press plug (2).
3. Remove plug, Valve spring (3), Valve (4),  
If necessary assist with bent electrode wire.

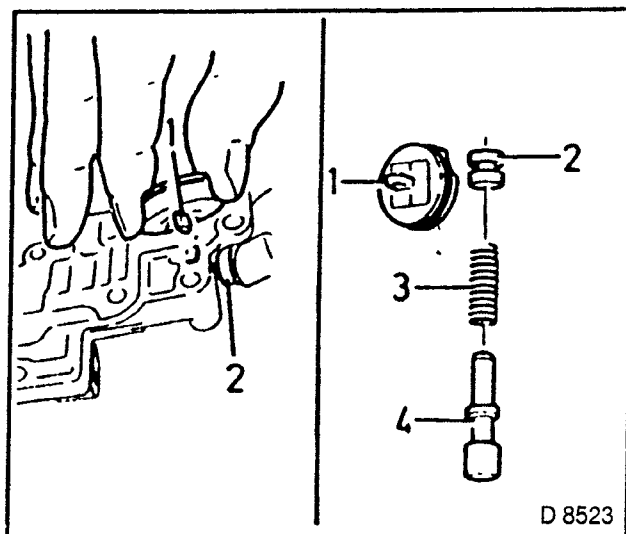


Fig 445

**INSPECT**

1. Valve spring for rust and deformation.  
Measure free length and outer diameter (caliper gauge).  
Length (Fig. 446, Item 5): 28.53 mm,  
diameter (Fig. 446, Item 6): 8.0 mm.
2. Valve for damage and wear as well as play — free seating in bore.

If springs do not have identical values, or if play between piston/valves and the affected bore is too large, replace valve body (completely).

**CLEAN**

1. Removed parts, ducts and sealing surfaces of front valve body.
2. Blow dry and oil.

**ASSEMBLE**

1. Front valve body — insert modulator valve, valve spring, plug and lock with wedge.

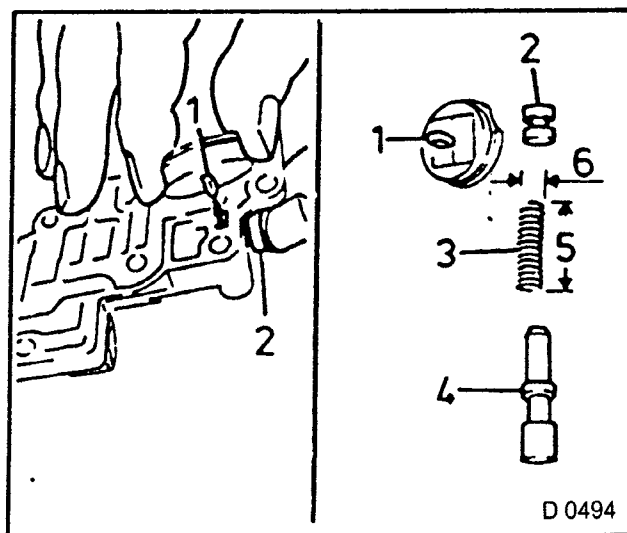
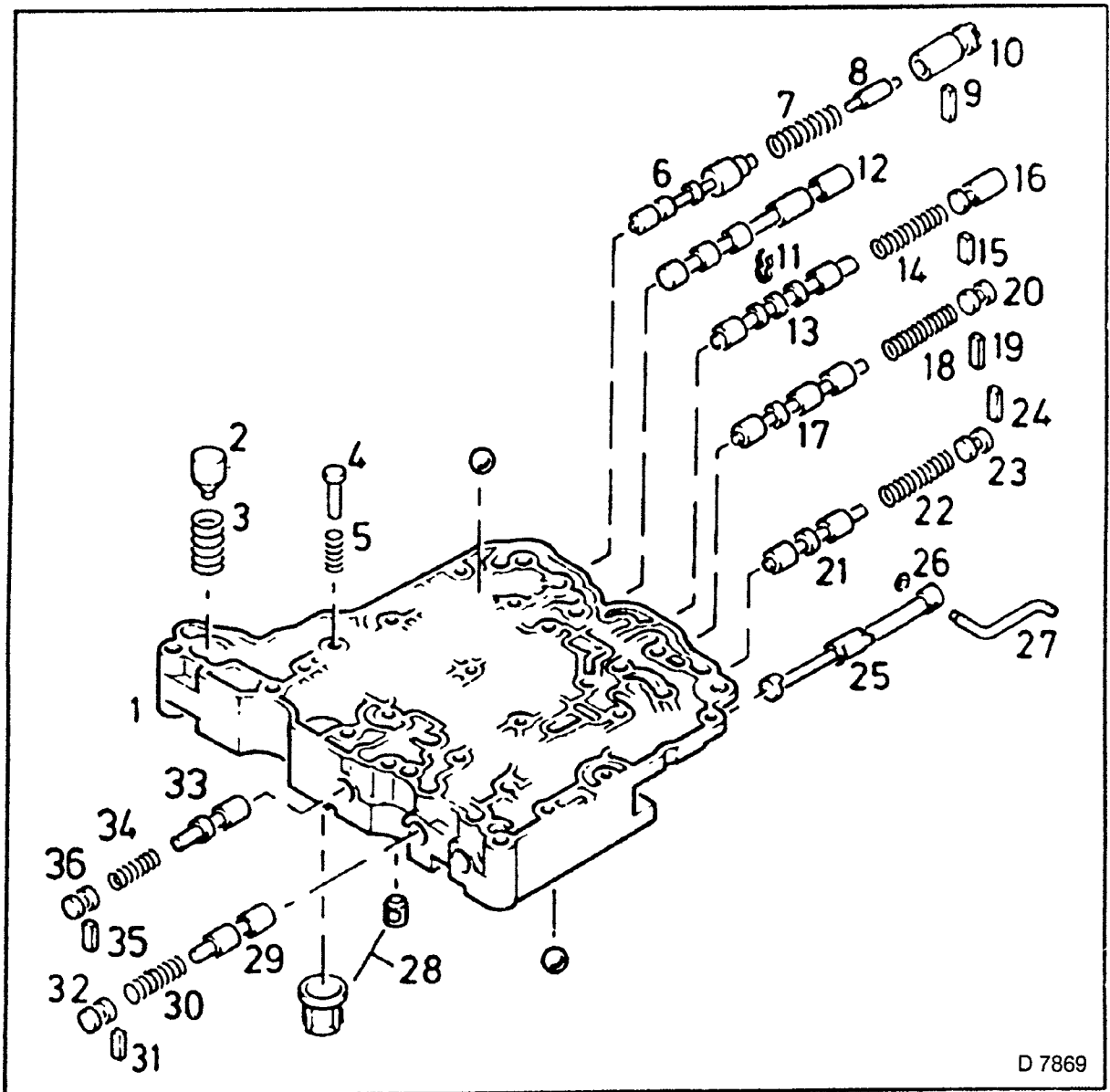


Fig. 446



D 7869

Fig. 447 — Centre Valve Body

- |                                   |                                |
|-----------------------------------|--------------------------------|
| 1 = Centre valve body             | 19 = 3/4 shift valve wedge     |
| 2 = Bypass valve                  | 20 = 3/4 shift valve plug      |
| 3 = Bypass valve spring           | 21 = 2/3 shift valve           |
| 4 = Safety valve                  | 22 = 2/3 shift valve spring    |
| 5 = Safety valve spring           | 23 = 2/3 shift valve plug      |
| 6 = Primary control valve         | 24 = 2/3 shift valve wedge     |
| 7 = Primary control valve spring  | 25 = Manual selector valve     |
| 8 = Primary control valve piston  | 26 = Retainer ring             |
| 9 = Primary control valve wedge   | 27 = Manual selector valve rod |
| 10 = Primary control valve sleeve | 28 = Fluid filters (4)         |
| 11 = Retaining bracket            | 29 = Valve B1                  |
| 12 = Plug for neutral control     | 30 = Spring B1                 |
| 13 = 1/2 shift valve              | 31 = Wedge B1                  |
| 14 = 1/2 shift valve spring       | 32 = Plug B1                   |
| 15 = 1/2 shift valve wedge        | 33 = Bridge valve              |
| 16 = 1/2 shift valve plug         | 34 = Bridge valve spring       |
| 17 = 3/4 shift valve              | 35 = Bridge valve plug         |
| 18 = 3/4 shift valve spring       | 36 = Bridge valve wedge        |

**DISASSEMBLE**

- Centre valve body.
- Three fluid filters — small (1).
- One fluid filter — large (2).
- One lock ball (3).

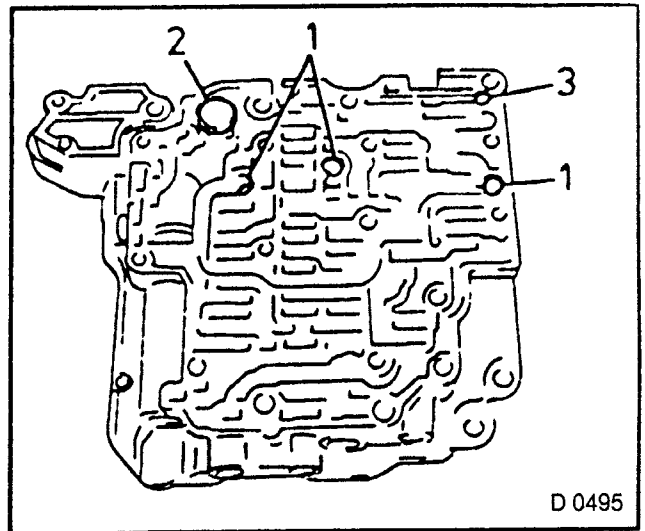


Fig. 448

**REMOVE, DISCONNECT**

1. Turn centre valve body.
2. Remove plate and gaskets.
3. Lock balls (1 to 8 except 3).
4. Bypass valve with spring (9).
5. Check valve with spring (10).

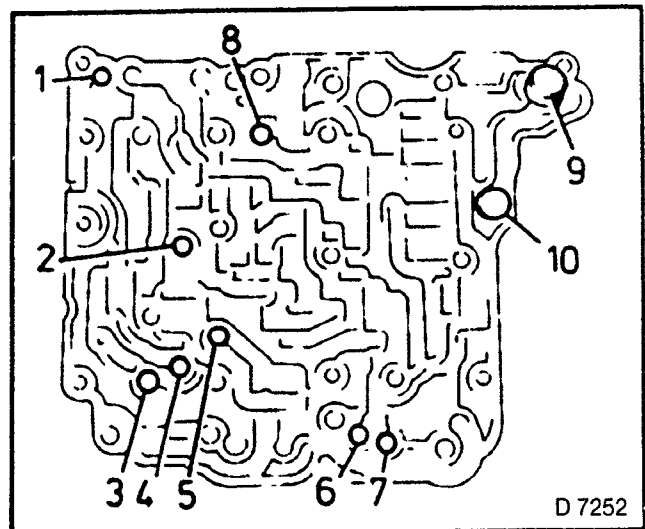


Fig. 449

**REMOVE, DISCONNECT**

1. Press valve B1 — onto plug (1).
2. Remove wedge (2) with magnetic lifter.
3. Remove plug.
4. Spring (3).
5. Valve (4).

If necessary assist with bent electrode wire.

**INSPECT**

1. Play-free seating of valve in its bore.
2. Valve spring (3) for rust and deformation.
3. Measure valve spring,  
Caliper gauge, free length: 29.7 mm,  
Outer diameter: 8.3 mm.

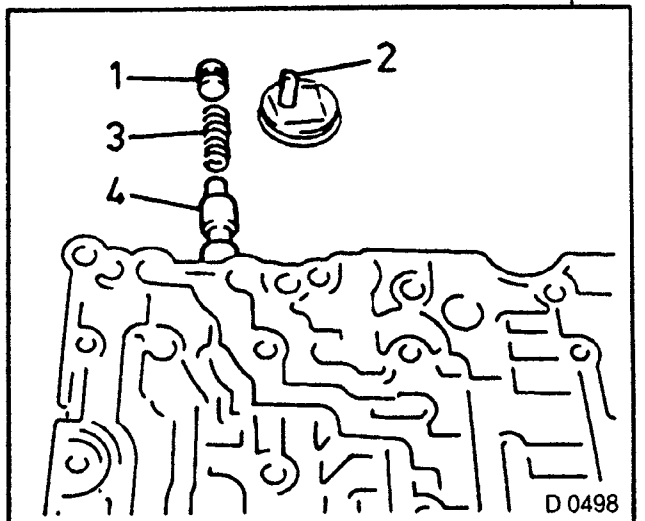


Fig. 450

**REMOVE, DISCONNECT**

- 1 Bridge valve — wedge (1)
- 2 Plug (2)
- 3 Spring (3).
4. Valve (4).

Removal as for valve B1.

**INSPECT**

Same procedure as for valve B1

Free length: 22.42 mm,

Outer diameter: 8.0 mm

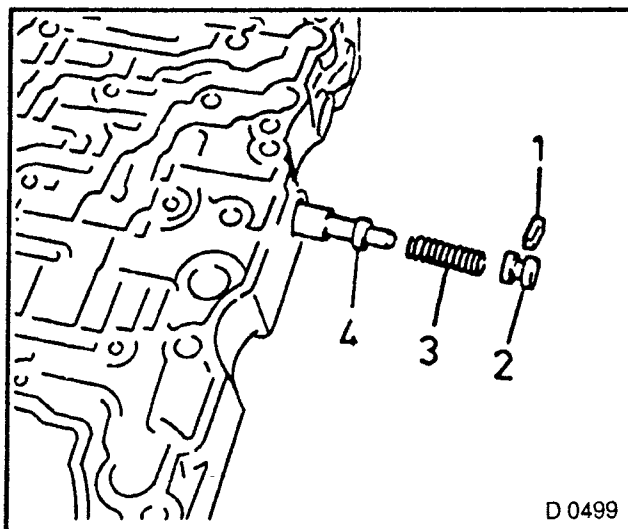


Fig. 451

**REMOVE, DISCONNECT**

1. Primary control valve.
2. Remove wedge (1),  
Press on sleeve (2) with screwdriver,  
sleeve (2), piston (3), spring (4), valve (5),  
removal as for valve B1, single parts in  
Fig. 453.

**INSPECT**

Same procedure as for valve B1,

Free length. 29.72 mm,

Outer diameter: 10.5 mm.

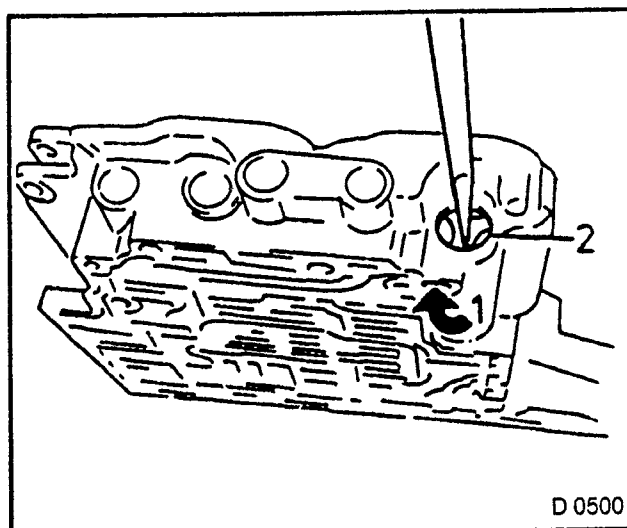


Fig. 452

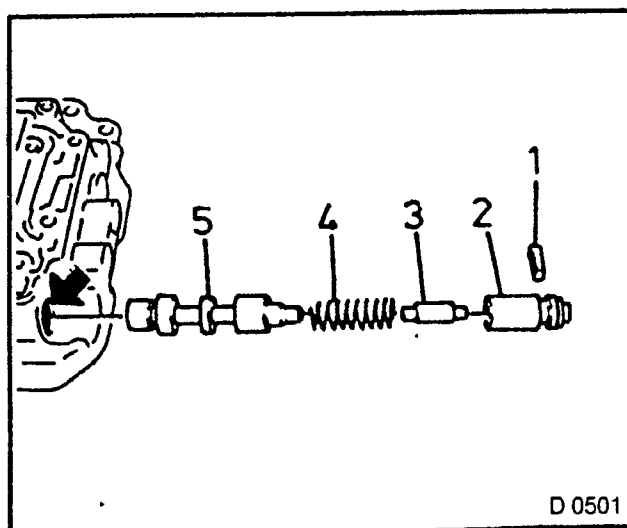


Fig. 453

**REMOVE, DISCONNECT**

1. Plug for neutral control.
2. Retaining bracket (1) — hook out with small screwdriver, remove plug (2), if necessary strike lightly against wooden base.

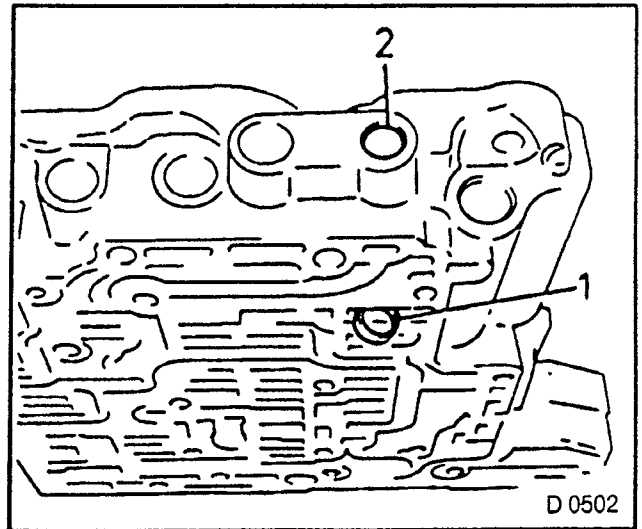


Fig. 454

**INSPECT**

1. Play — free seating of plug in bore.

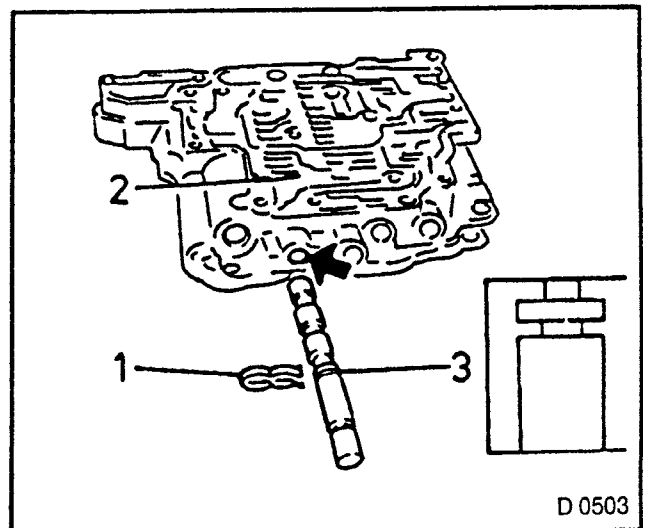


Fig. 455

**REMOVE, DISCONNECT**

1. Remove 1/2 shift valve —  
Wedge (1),  
Plug (2),  
Spring (3).  
Valve (4).  
Removal as for valve B1.

**INSPECT**

Same procedure as for valve B1,  
Free length: 34.0 mm,  
Outer diameter: 8.2 mm.

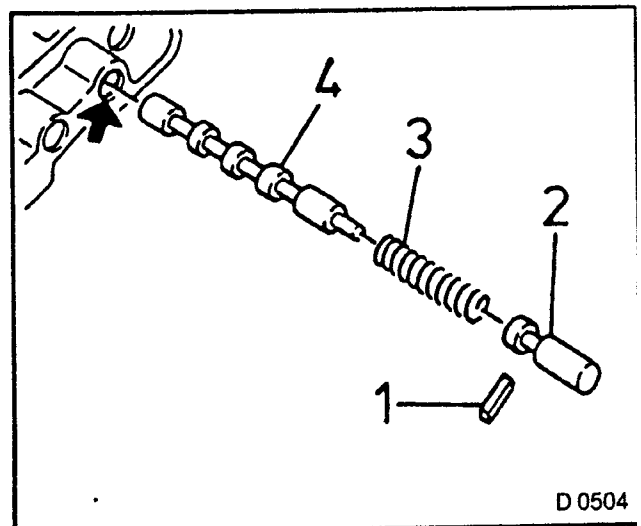


Fig. 456

**REMOVE, DISCONNECT**

1. Remove 3/4 shift valve —  
Wedge (1),  
Plug (2),  
Spring (3),  
Valve (4),  
Removal as for valve B1.

**INSPECT**

Same procedure as for valve B1.  
Free length: 34.0 mm.  
Outer diameter: 8.2 mm.

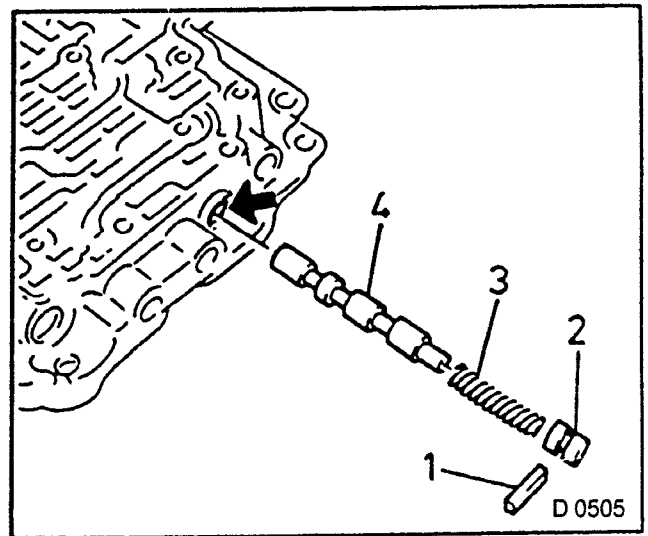


Fig. 457

**REMOVE, DISCONNECT**

1. Remove 2/3 shift valve,  
Wedge (1),  
Plug (2),  
Spring (3),  
Valve (4).  
Removal as for valve B1.

**INSPECT**

Same procedure as for valve B1.  
Free length: 33.95 mm.  
Outer diameter: 8.2 mm.

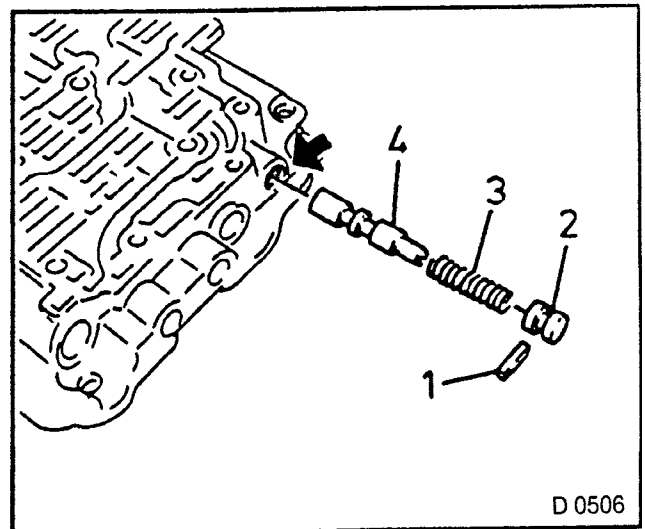


Fig. 458

If springs do not have identical values, or if play between piston/valves and the affected bore is too large, replace valve body (completely).

**CLEAN**

1. Removed parts, ducts and sealing surfaces of centre valve body.
2. Blow dry and lubricate.

**ASSEMBLE**

1. Centre valve body.  
Always renew gaskets of plates, fluid filters
2. Renew as needed lock balls. Valves are located under plates (bypass and check valves).
3. Selector slide and selector rod.

**INSTALL, CONNECT**

1. Valve B1.
2. Valve (4).
3. Spring (3).
4. Plug (1) in bore.
5. Press on plug.
6. Insert wedge (2) with magnetic lifter.

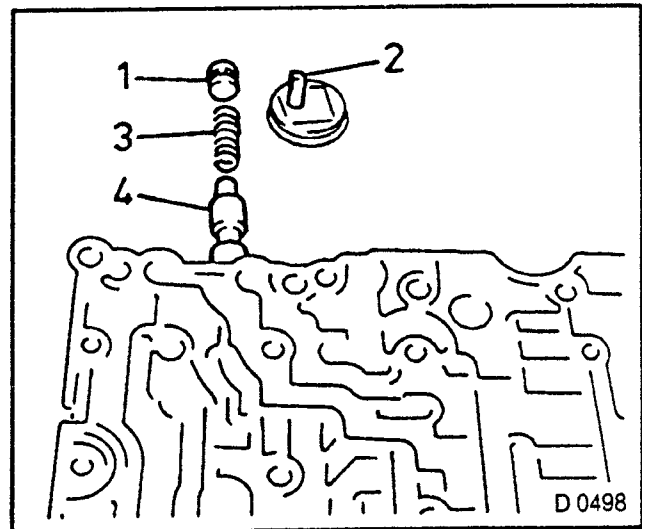


Fig. 459

**INSTALL, CONNECT**

1. Bridge valve — valve (4).
2. Spring (3).
3. Plug (2) in bore.
4. Insert wedge (1).

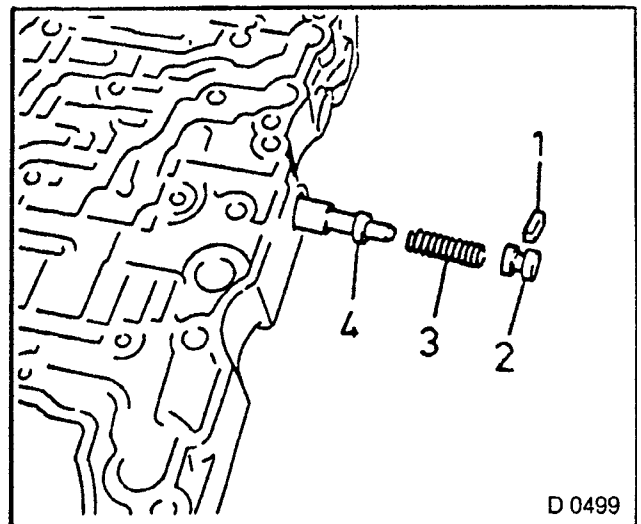


Fig. 460

**INSTALL, CONNECT**

1. Primary control valve — valve (5).
2. Spring (4).
3. Piston (3).
4. Sleeve (2) in bore (arrow).
5. Insert wedge (1)

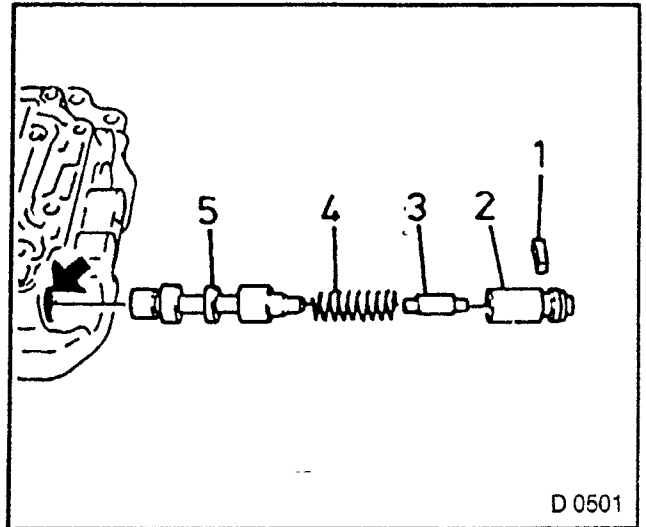


Fig. 461

**INSTALL, CONNECT**

1. Plug for neutral control.
2. Plug in bore (arrow).
3. Insert retaining bracket (1) in position (2).
4. Snap into groove of plug (3).

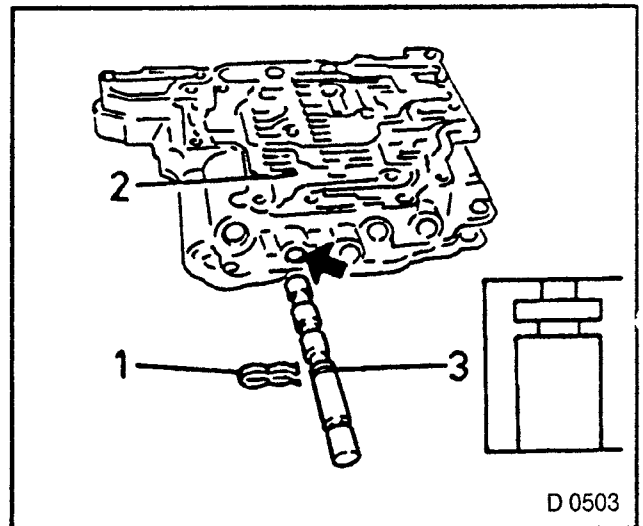


Fig. 462

**INSTALL, CONNECT**

1. 1/2 shift valve — valve (4).
2. Spring (3).
3. Plug (2) in bore (arrow).
4. Insert wedge (1)

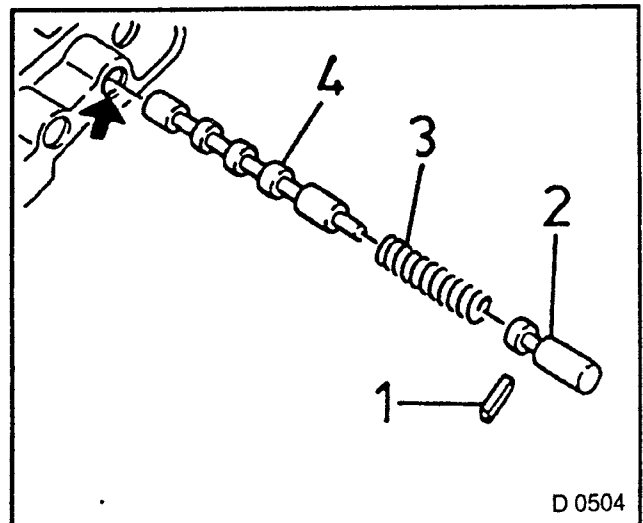


Fig. 463



**INSTALL, CONNECT**

1. 3/4 shift valve — valve (4).
2. Spring (3).
3. Plug (2) in bore (arrow).
4. Insert wedge (1).

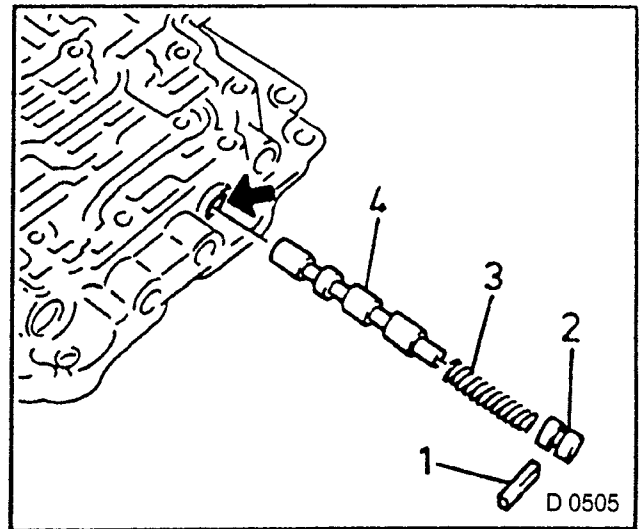


Fig. 464

**INSTALL, CONNECT**

1. 2/3 shift valve — valve (4).
2. Spring (3).
3. Plug (2) in bore (arrow).
4. Insert wedge (1).

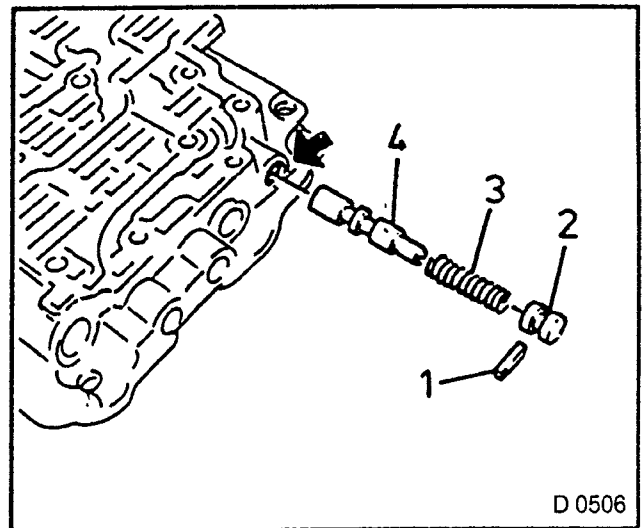


Fig. 465

**ASSEMBLE**

1. Centre valve body — bypass valve with spring (9).
2. Check valve with spring (10)
3. All lock balls except No. 3
4. Plate with new gaskets on sealing surface.

**NOTE:**  
OBSERVE HOLE ALIGNMENT  
POSITION OF PLATE AND GASKETS.

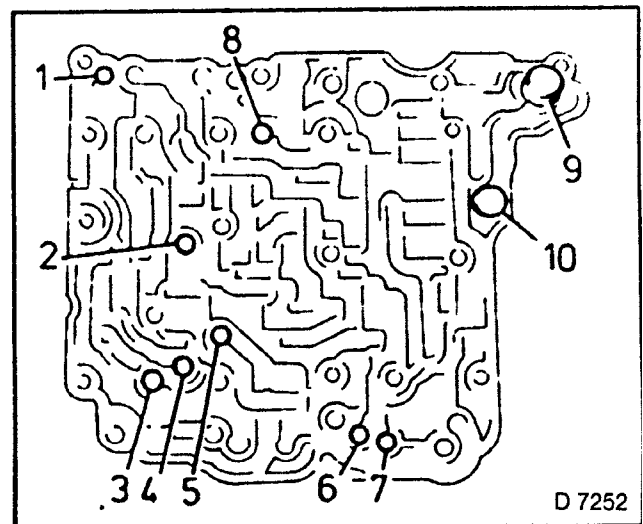
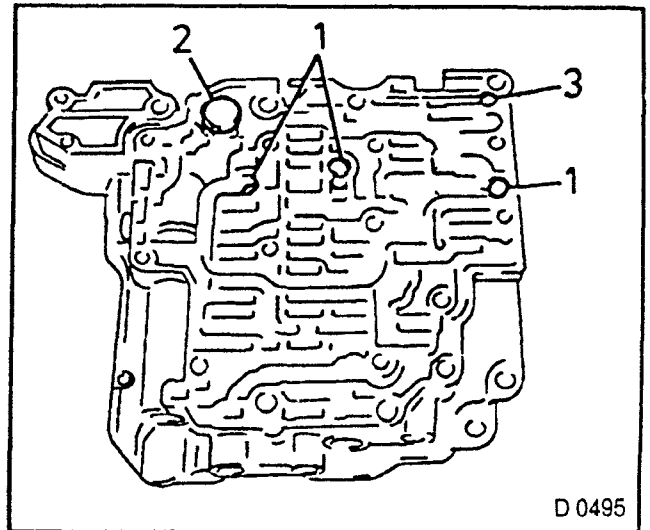


Fig. 466

5. Compress springs of bypass and check valves with plate.
6. Turn centre valve body.
7. Set aside on plate and place under weight, so that lock balls remain at their installation positions.

### INSTALL, CONNECT

1. Three fluid filters (1) — small, closed side points downwards.
2. One fluid filter (2) — large, closed side points upwards.
3. One lock ball (3)



D 0495

Fig 467

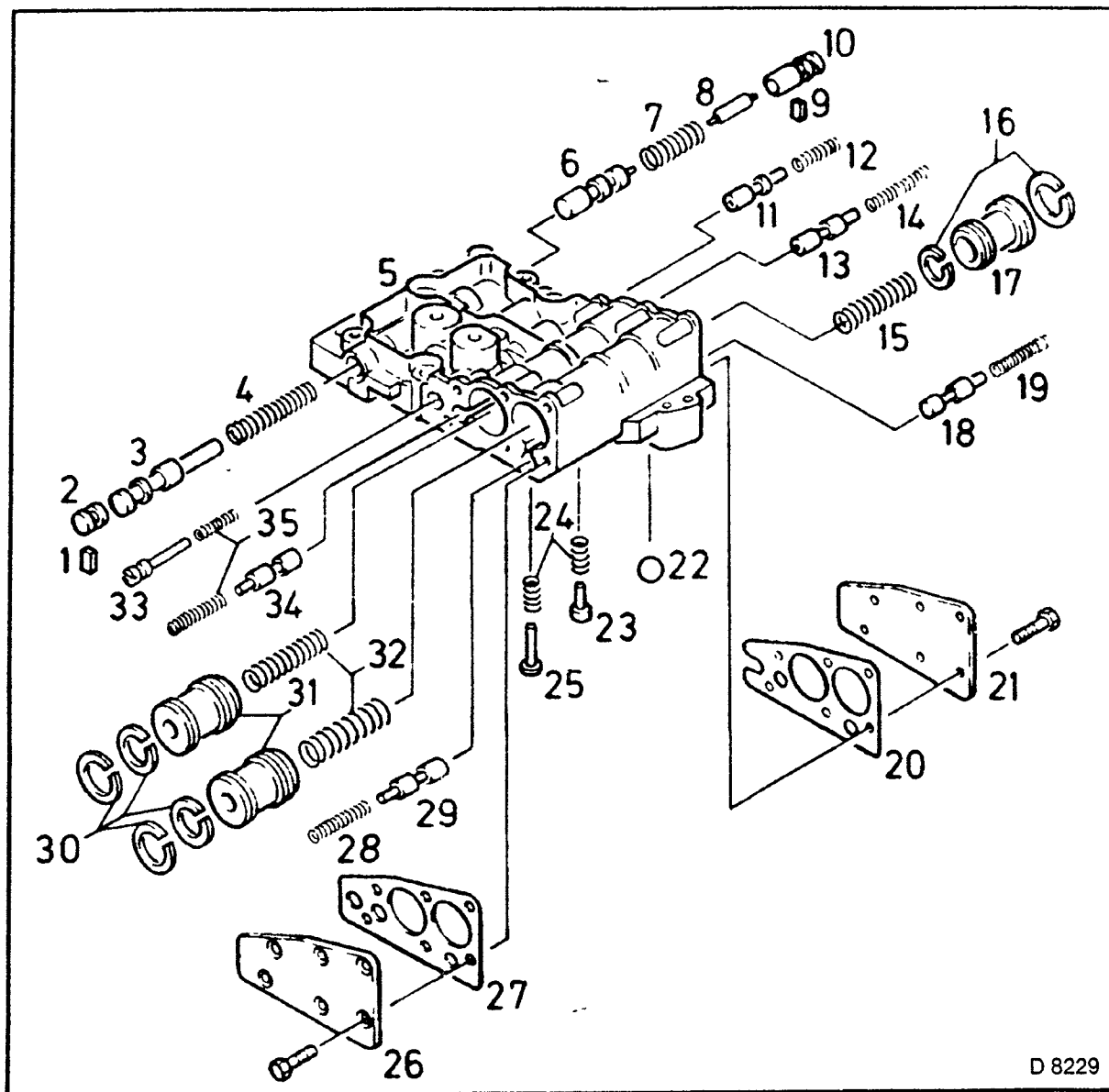


Fig. 468 — Rear Valve Body.

D 8229

- |   |   |
|---|---|
| 1 = Wedge for secondary control valve   | 20 = Gasket for cover no. 2                   |
| 2 = Plug for secondary control valve    | 21 = Cover no. 2                              |
| 3 = Secondary control valve             | 22 = Lock balls (4)                           |
| 4 = Spring for secondary control valve  | 23 = Safety valve                             |
| 5 = Rear valve body                     | 24 = Pressure springs                         |
| 6 = Bridge control valve                | 25 = Check valve                              |
| 7 = Spring for bridge control valve     | 26 = Cover no. 1                              |
| 8 = Sleeve for bridge control valve     | 27 = Gasket for cover no. 1                   |
| 9 = Wedge for bridge control valve      | 28 = Spring for accumulator valve C2          |
| 10 = Piston for bridge control valve    | 29 = Accumulator valve C2                     |
| 11 = Freewheel modulator valve          | 30 = Seal rings for accumulator piston B2, C2 |
| 12 = Spring for freewheel modular valve | 31 = Accumulator piston B2, C2                |
| 13 = Modulator valve for clutch         | 32 = Springs for accumulator piston B2, C2    |
| 14 = Modular valve spring for clutch    | 33 = Accumulator control valve                |
| 15 = Spring for accumulator piston C3   | 34 = Accumulator valve B2                     |
| 16 = Seal rings                         | 35 = Pressure springs                         |
| 17 = Accumulator piston C3              |   |
| 18 = Accumulator valve C3               |   |
| 19 = Spring for accumulator valve C3    |   |

**DISASSEMBLE**

1. Rear valve body.
2. Check valve with spring (1), safety valve with spring (2), Three lock balls (3).

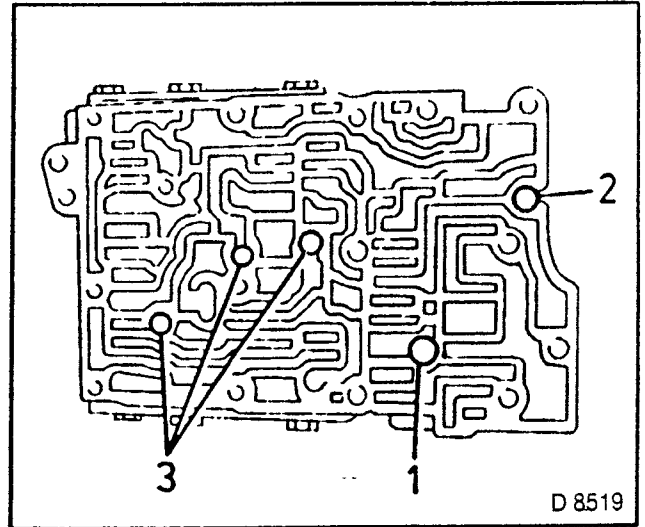


Fig. 469

3. Secondary control valve.
4. Press against plug (2).
5. Remove wedge (1) with magnetic lifter.
6. Remove plug.
7. Valve (3).
8. Spring (4).

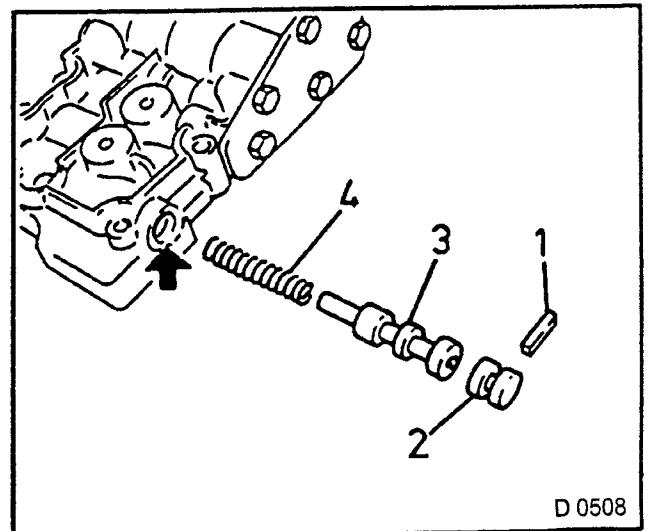


Fig. 470

**INSPECT**

1. Play — free seating of valve in bore.
2. Valve spring (3) for rust and deformation.
3. Measure spring, caliper gauge.  
Free length: 47.44 mm,  
Outer diameter: 9.5 mm.

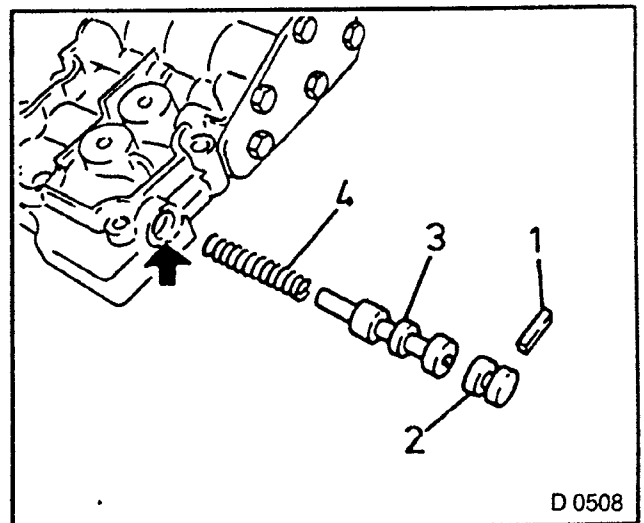


Fig. 471

**REMOVE, DISCONNECT**

1. Cover no 1 from rear valve body — six bolts.

**CAUTION:**  
**CAREFULLY REMOVE COVER AND GASKET, SPRINGS LOCATED IN REAR CAN SPRING OUT.**

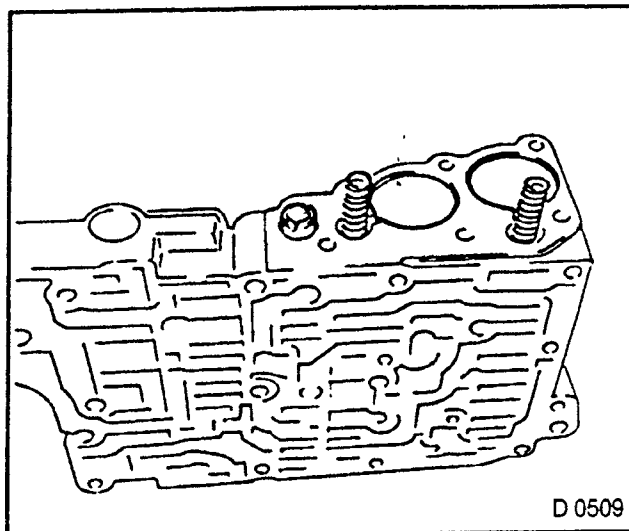


Fig. 472

**REMOVE, DISCONNECT**

1. Accumulator control valve with spring (1).
2. Accumulator valve B2 with spring (2).
3. Accumulator piston B2 with spring (3).
4. Accumulator piston C2 with spring (4).
5. Accumulator valve C2 with spring (5).
6. Seal rings of accumulator piston B2 and C2 — to clean the ring grooves.

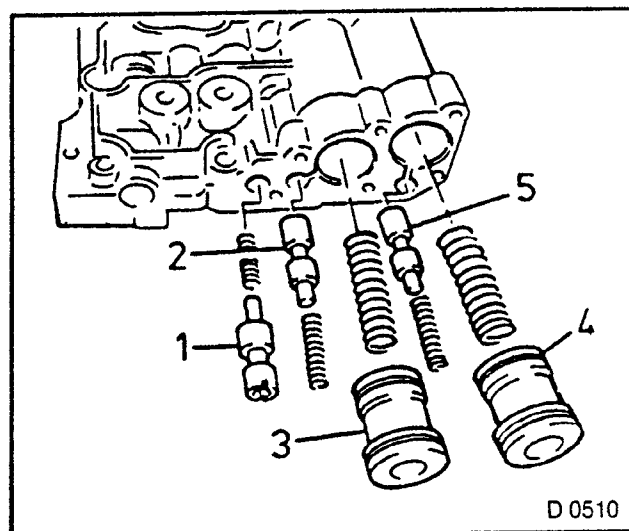


Fig. 473

**INSPECT**

1. Play — free seating of piston and valves in bores.
2. Springs for rust and deformation.

**MEASURE**

1. Free lengths and outer diameters of springs (1 to 5).  
 Caliper gauge, values in following table:

| No | Component.         | Free length | Outer diameter: |
|----|--------------------|-------------|-----------------|
| 1. | Acc.-control valve | 21.89 mm    | 6.0 mm          |
| 2. | Acc. valve B2      | 32.77 mm    | 7.0 mm          |
| 3. | Acc piston B2      | 46.0 mm     | 11.5 mm         |
| 4. | Acc. piston C2     | 46.0 mm     | 11.5 mm         |
| 5. | Acc. valve C2      | 32.77 mm    | 7.0 mm          |

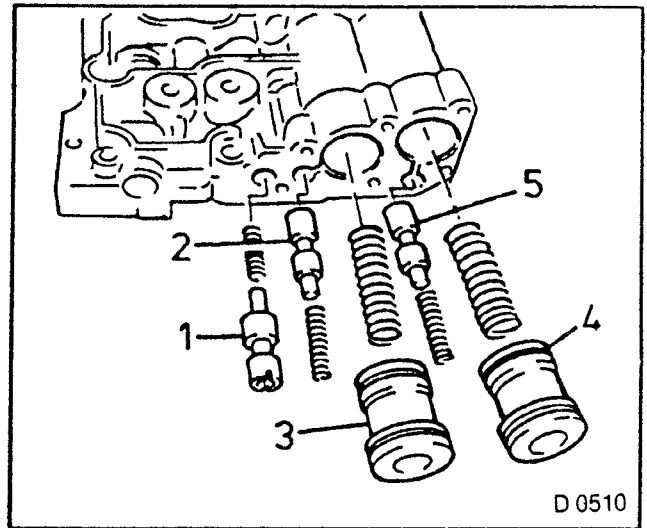


Fig. 474

### REMOVE DISCONNECT

- Control valve bridge — same procedure as for secondary control valve.  
Remove wedge (1),  
Sleeve (2),  
Piston (3),  
Spring (4),  
Control valve (5).

### INSPECT

- Seating of valve in bore without play.
- Valve spring for rust and deformation.
- Measure spring, caliper gauge.  
Free length: 65.0 mm.  
Outer diameter: 9.6 mm.

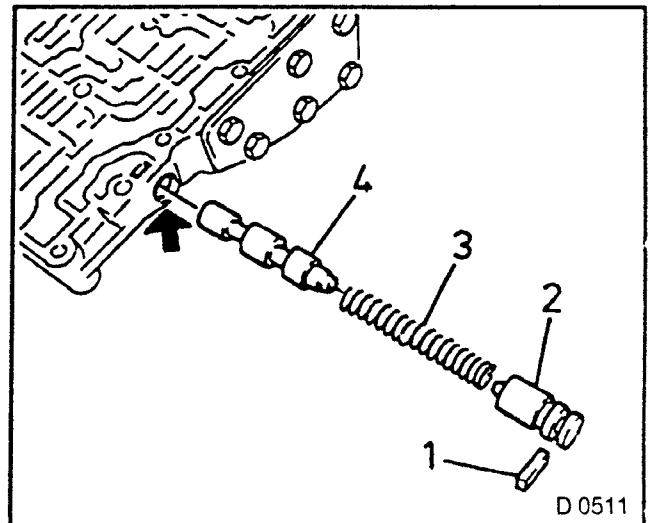


Fig. 475

### REMOVE, DISCONNECT

- Cover no. 2 from rear valve body — six bolts.

**CAUTION:**  
CAREFULLY REMOVE COVER,  
SPRINGS LOCATED IN REAR CAN  
SPRING OUT.

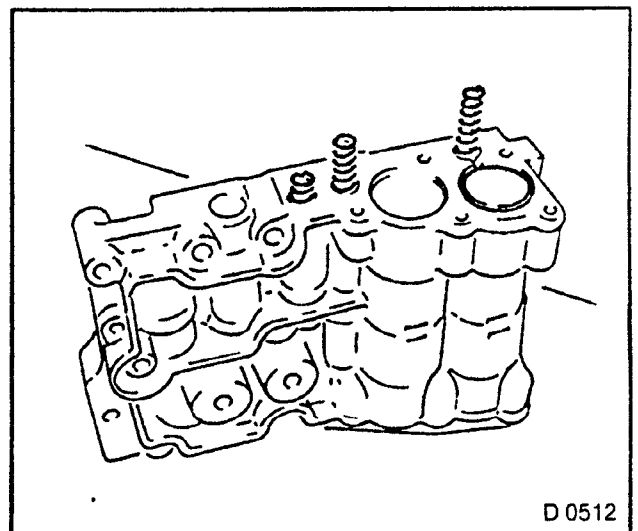


Fig 476

**REMOVE, DISCONNECT**

1. Freewheel modulator valve — with spring (1).
2. Modulator valve for clutch with spring (2)
3. Accumulator piston C3 with spring (3)
4. Accumulator valve C3 with spring (4)
5. Hook seal rings from piston C3 — for cleaning ring groove.
6. Ring ends are L-shaped.
7. Press one ring end in groove
8. Hook out the other.
9. As cut seal ring without hooks on new transmissions.

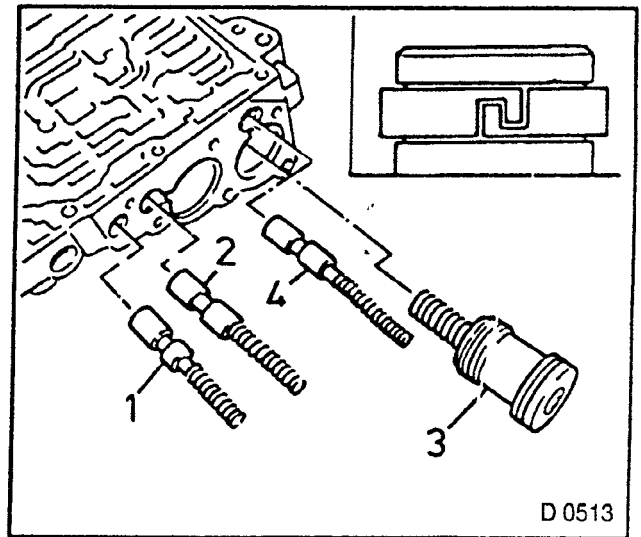


Fig. 477

**INSPECT**

1. Seating of piston and valves in bores without play.
2. Springs for rust and deformation.

**MEASURE**

1. Free lengths and outer diameters of springs (1 to 4).  
Caliper gauge, values in following table.

| No | Component:        | Free length | Outer diameter: |
|----|-------------------|-------------|-----------------|
| 1. | Freewheel valve   | 64.94 mm    | 9.6 mm          |
| 2. | Clutch mod. valve | 28.53 mm    | 8.0 mm          |
| 3. | Acc. piston C3    | 46.0 mm     | 11.6 mm         |
| 4. | Acc. valve C3     | 30.67 mm    | 7.0 mm          |

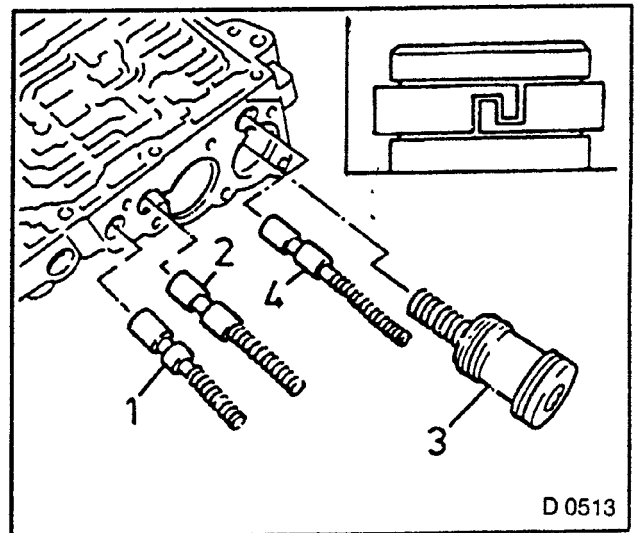


Fig. 478

**NOTE:**

If springs do not have identical values, or if play between piston/valves and the affected bore is too large, replace valve body (completely).

**CLEAN**

1. Removed parts, ducts and sealing surfaces of rear valve body
2. Blow dry and lubricate.

**INSTALL, CONNECT**

1. Secondary control valve — spring (4)  
Valve (3).  
Plug (2) in bore (arrow).  
Insert wedge (1).

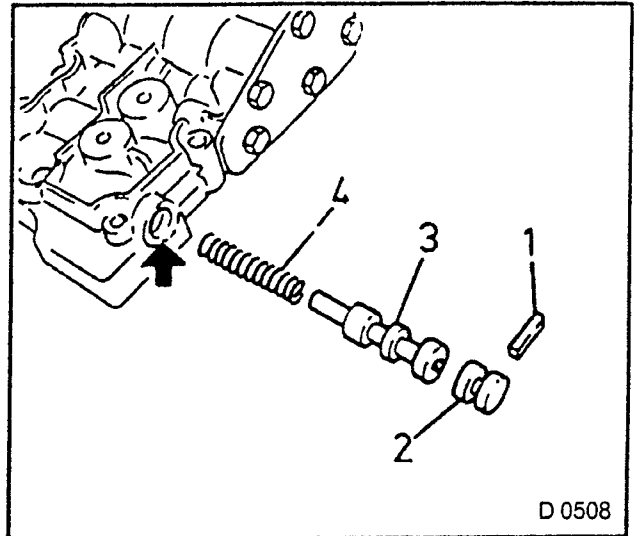


Fig. 479

**INSTALL, CONNECT**

1. Accumulator control valve with spring (1).
2. Accumulator valve B2 with spring (2).
3. Accumulator piston B2 with spring (3).
4. Accumulator piston C2 with spring (4).
5. Accumulator valve C2 with spring (5).
6. Seal rings on accumulator pistons C2 and B2.

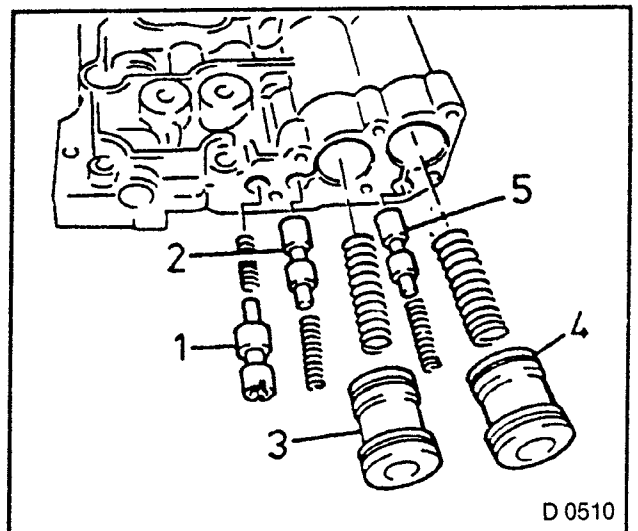


Fig. 480

**TIGHTEN (TORQUE)**

1. Cover no. 1 with new gasket to rear valve body — 7 Nm.  
**DO NOT** bend projecting springs.

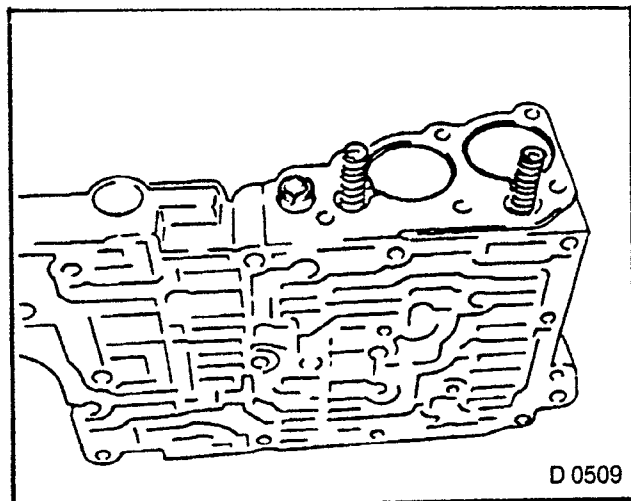


Fig. 481



**INSTALL, CONNECT**

1. Bridge control valve — valve (4).  
Spring (3).  
Sleeve (2) in bore (arrow)  
Insert wedge (1).

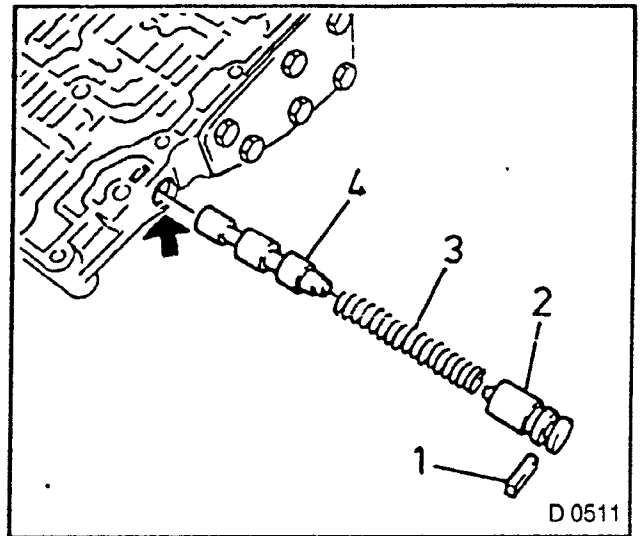


Fig. 482

**INSTALL, CONNECT**

1. Freewheel modulator valve with spring (1).
2. Modulator valve for clutch with spring (2).
3. Accumulator piston C3 with spring (3).
4. Accumulator valve C3 with spring (4).
5. Seal rings on piston C3 — ring ends are L-shaped.
6. Press one ring end in groove, hook in the other, in doing so, do not overstretch. As cut seal ring without hooks on new transmissions.

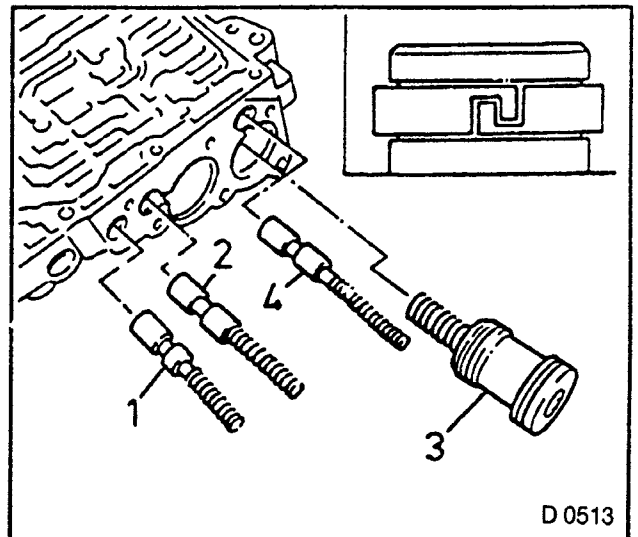


Fig. 483

**INSTALL, CONNECT**

1. Cover no. 2 with new gasket to rear valve body — 7 Nm.  
**DO NOT** bend projecting springs.

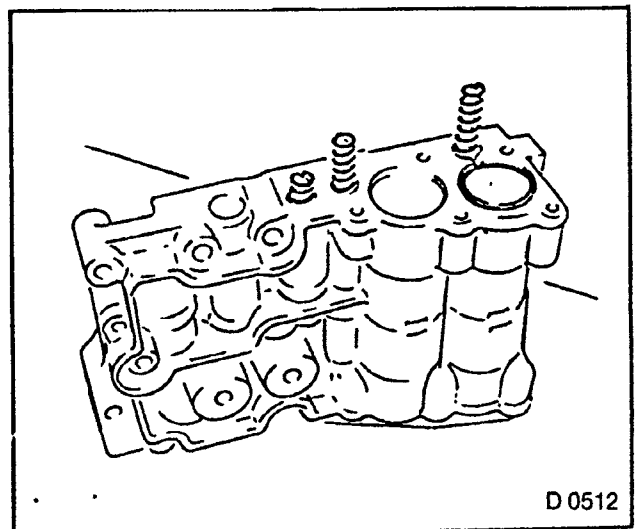


Fig. 484

**ASSEMBLE**

1. Rear valve body.
2. Check valve with spring (1).
3. Safety valve with spring (2)
4. Three lock balls (3)

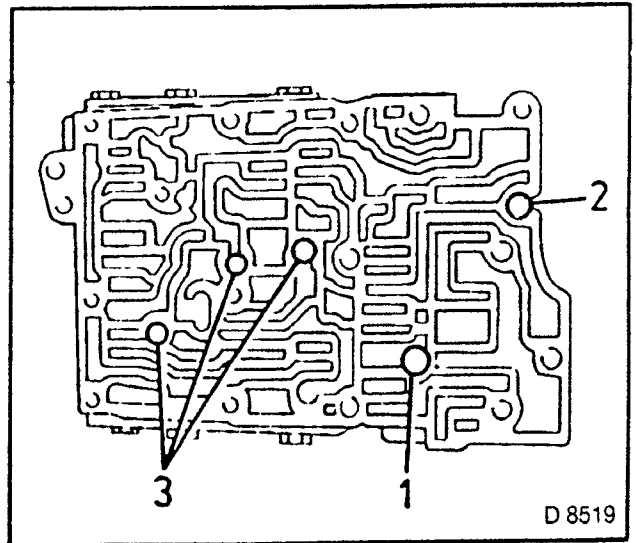


Fig. 485

**TIGHTEN (TORQUE)**

1. Centre to rear valve body (1) — 7 Nm.

**CAUTION**

1. Rear valve body is first left lying on underside.
2. Centre valve body with plate and gasket (2) to rear valve body.
3. Keep compressed, so that lock balls and spring-tensioned valves DO NOT fall out.
4. Turn assembly and screw in bolts (1).

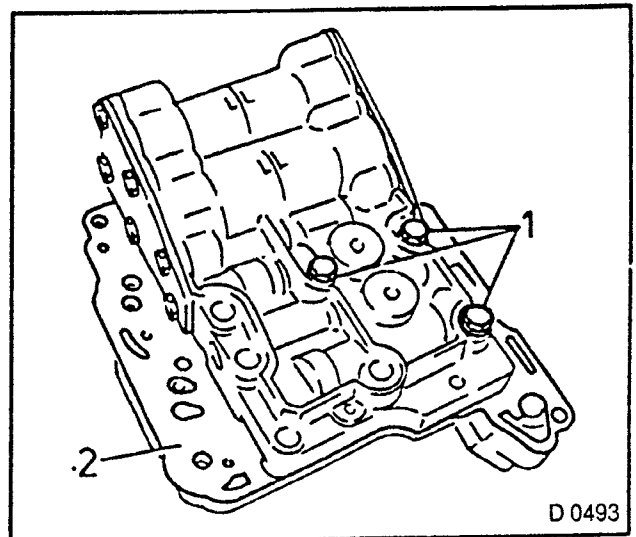


Fig 486

**TIGHTEN (TORQUE)**

1. Front to centre valve body — 7 Nm.
2. Place plate and new gaskets on top side of centre valve body. Check hole alignment position.
3. Begin with Five bolts (2).
4. Turn assembly and screw in Four bolts (1).

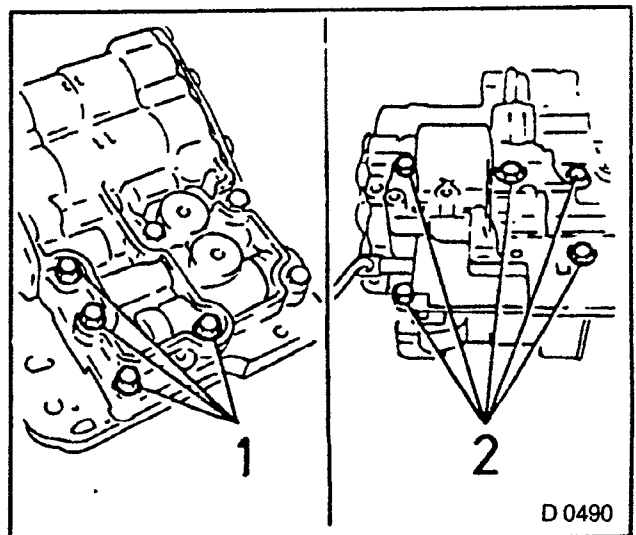


Fig. 487

5. Three solenoid valves (2) with new rubber O-seal rings — 7 Nm.
6. Terminal in groove of fluid pressure regulator (3) — 7 Nm., align valve so that wiring harness plug can be installed.
7. Two cable retainers (1) — align as shown, 7 Nm.

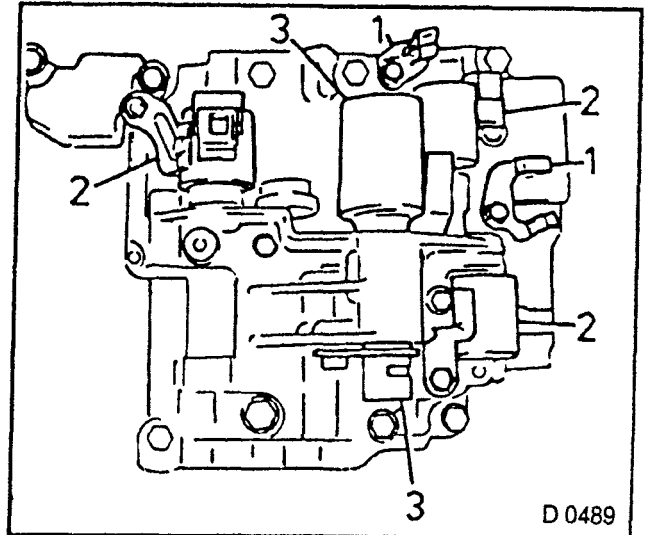


Fig. 488

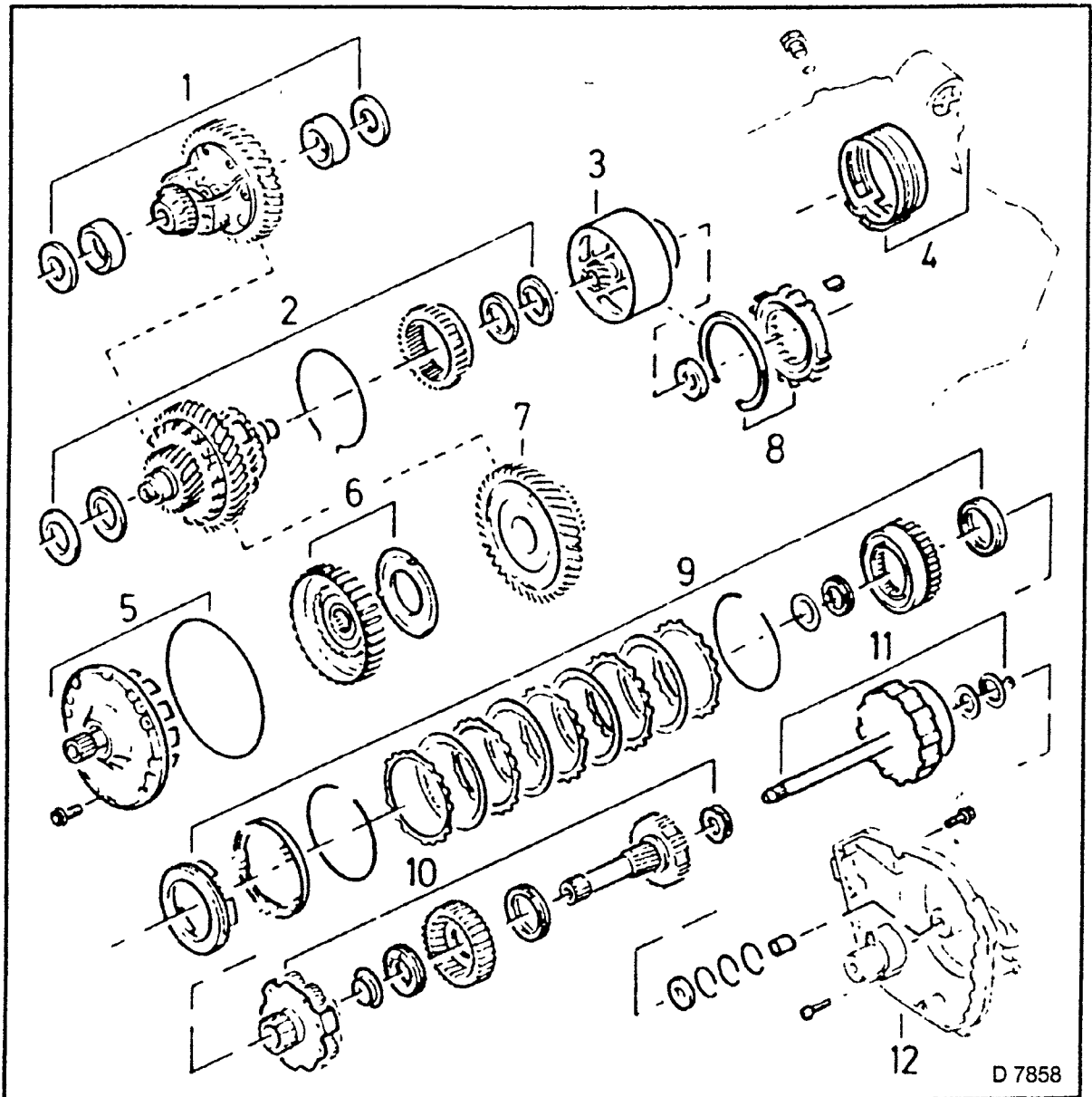


Fig. 489 — AF 20 Assemblies.

- 1 = Differential
- 2 = Planetary gear set P2
- 3 = Multi-plate clutch C3
- 4 = Brake band B4
- 5 = Fluid pump
- 6 = Freewheel F1
- 7 = Intermediate drive gear
- 8 = Freewheel F3
- 9 = Multi-disc brake B3 and freewheel F2
- 10 = Planetary gear set P1
- 11 = Multi-plate clutch C1 and C2, drive shaft assembly
- 12 = Rear cover

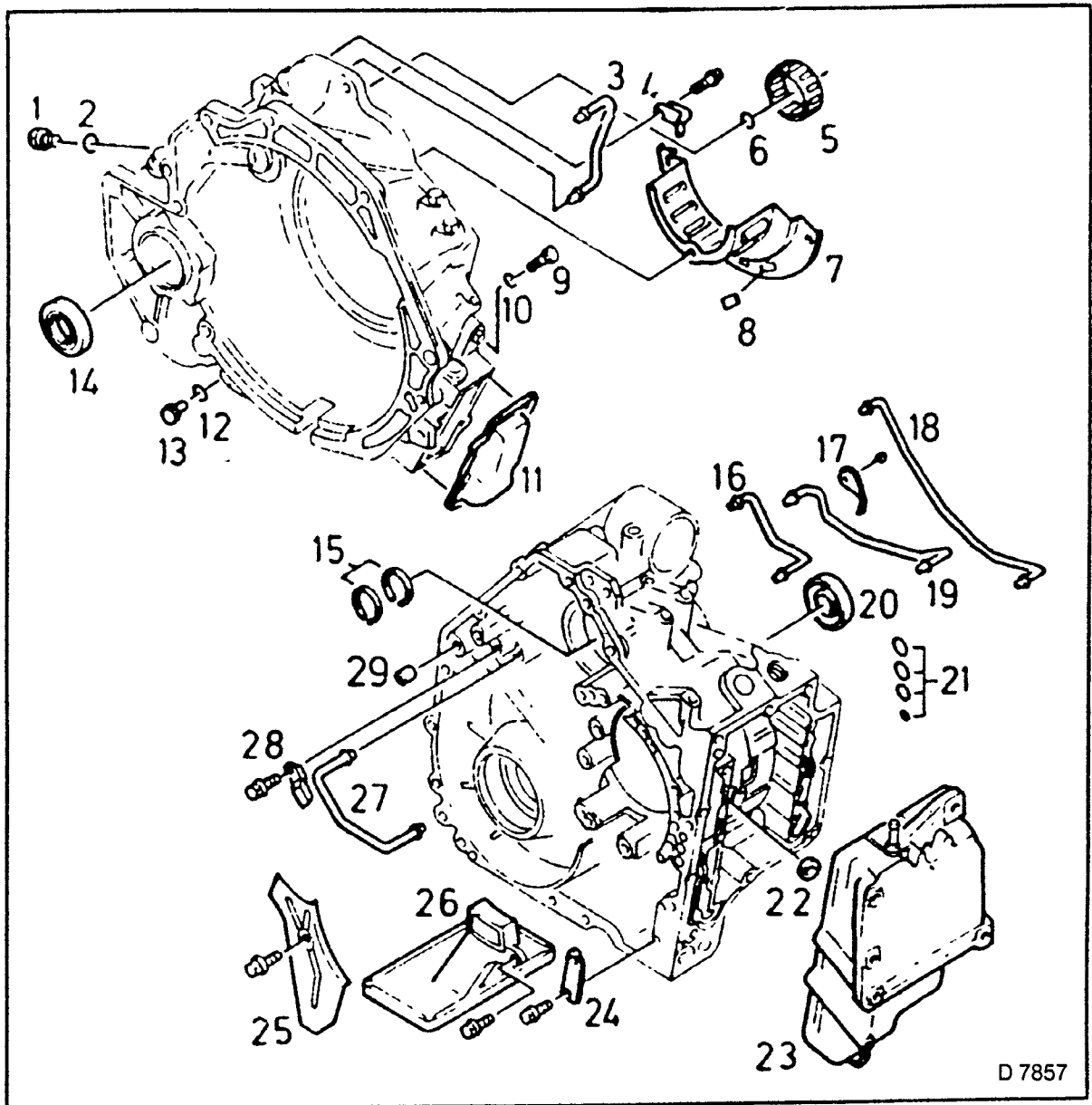


Fig. 490 — AF 20 Housing Parts

- |  |  |
|--|--|
| 1 = Plug M 8                                 | 15 = Hook seal rings                     |
| 2 = Seal ring                                | 16 = Main pressure pipe no. 1            |
| 3 = Lubricating fluid line                   | 17 = Pipe clamp                          |
| 4 = Pipe clamp                               | 18 = Actuation pipe                      |
| 5 = Roller bearing                           | 19 = Lubricating pipe                    |
| 6 = Seal ring                                | 20 = Axle shaft seal ring                |
| 7 = Fluid retaining plate, auxiliary housing | 21 = Gaskets for governor                |
| 8 = Magnets (3)                              | 22 = Gaskets for actuators (2)           |
| 9 = Plug M 8                                 | 23 = Side cover                          |
| 10 = Seal ring                               | 24 = Main housing plate                  |
| 11 = Auxiliary housing cover                 | 25 = Fluid retaining plate, main housing |
| 12 = Seal ring                               | 26 = Fluid filter                        |
| 13 = Drain bolt                              | 27 = Main pressure pipe no. 2            |
| 14 = Axle shaft seal ring                    | 28 = Pipe clamp                          |
|  | 29 = Seal ring                           |

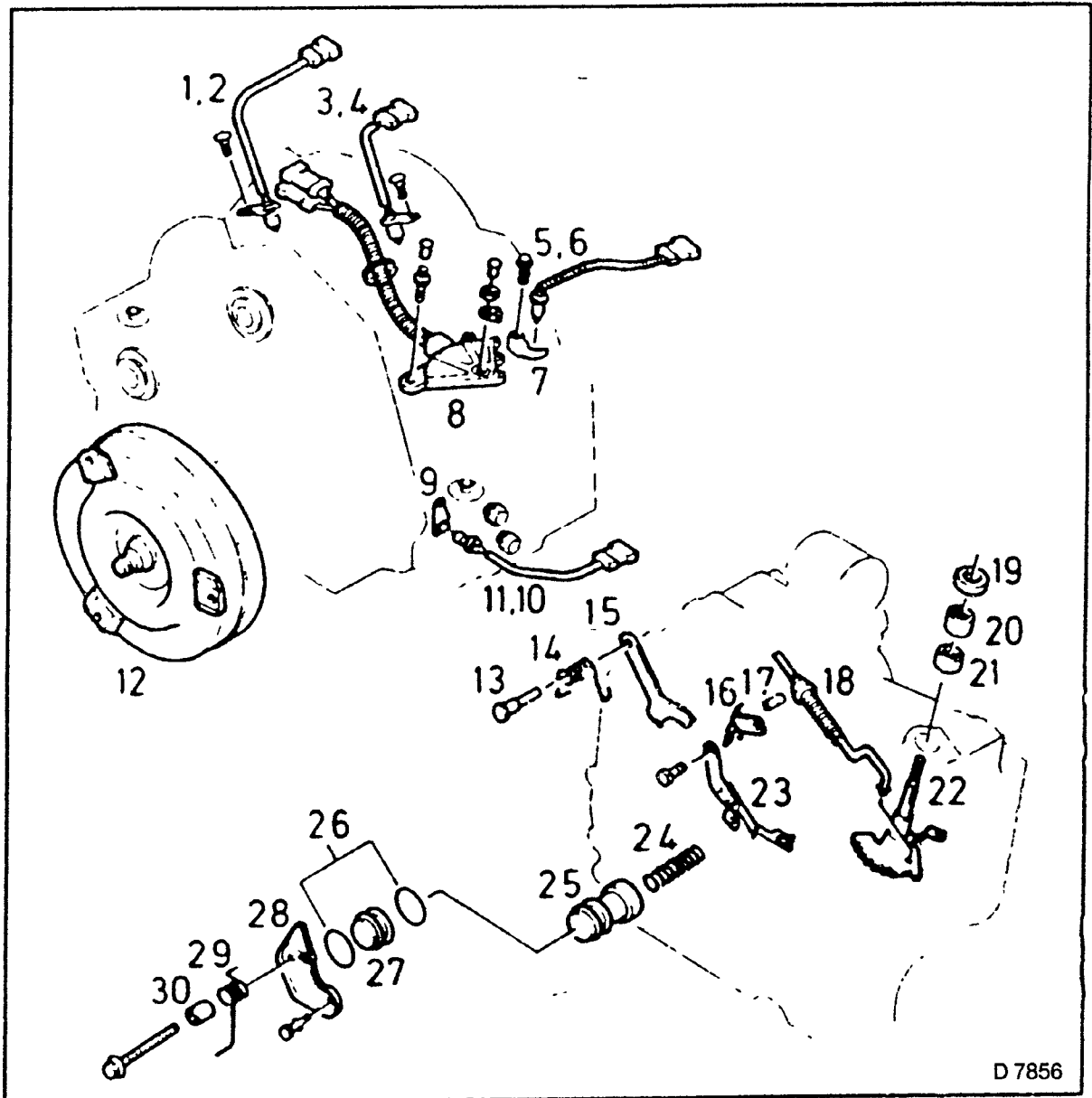
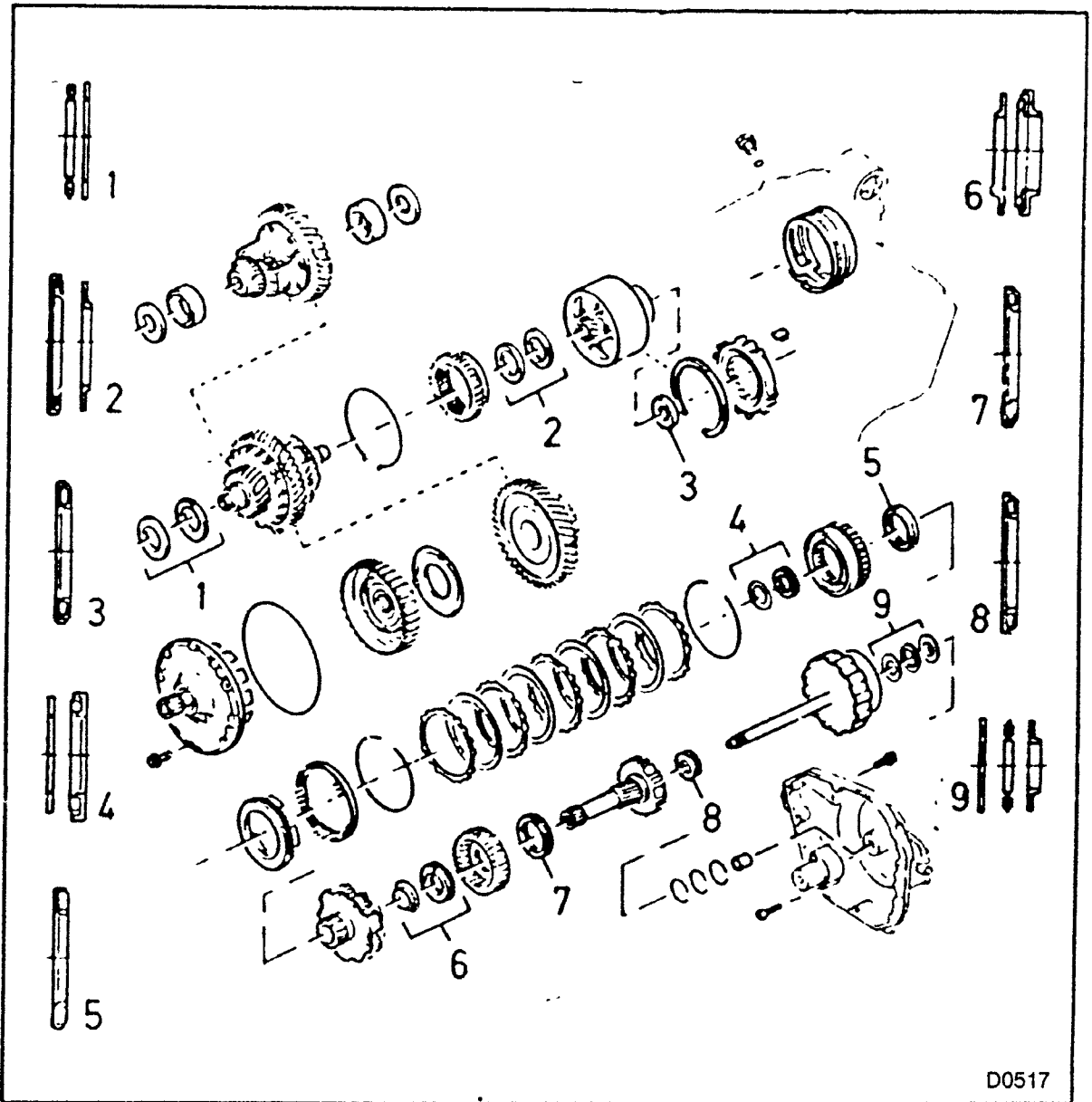


Fig. 491 — AF 20 Attaching Parts.

- |  |                                     |
|--|-------------------------------------|
| 1 = Sensor, transmission output speed        | 17 = Pin for parking pawl           |
| 2 = Seal ring                                | 18 = Actuation rod for parking pawl |
| 3 = Sensor, transmission input speed         | 19 = Seal ring                      |
| 4 = Seal ring                                | 20*) = Outer needle bearing         |
| 5 = Solenoid valve wiring harness            | 21*) = Inner needle bearing         |
| 6 = Seal ring                                | 22 = Ratchet                        |
| 7 = Retaining plate                          | 23 = Detent spring                  |
| 8 = Selector lever position switch           | 24 = Pressure spring                |
| 9 = Cover plate for fluid temperature sensor | 25 = Accumulator piston             |
| 10 = Seal ring                               | 26 = Seal rings                     |
| 11 = Fluid temperature sensor                | 27 = Cover for accumulator          |
| 12 = Converter                               | 28 = Bracket for accumulator        |
| 13 = Axle for parking pawl                   | 29 = Torsion spring no. 2           |
| 14 = Torsion spring no. 1                    | 30 = Sleeve for spring guide.       |
| 15 = Pawl for parking pawl                   |                                     |
| 16 = Cam plate                               |                                     |

\*) Single-part version on newer transmissions.



D0517

Fig. 492 — AF 20 Thrust Bearing Installation.

|                           | Outer 0 | Inner 0 |                           | Outer 0 | Inner 0 |
|---------------------------|---------|---------|---------------------------|---------|---------|
| 1 = Thrust bearing        | 71.0 mm | 49.0 mm | 7 = Thrust bearing        | 67.0 mm | 50.0 mm |
| Race assembly (rear)      | 71.0 mm | 49.1 mm | 8 = Thrust bearing        | 42.0 mm | 22.1 mm |
| 2 = Thrust bearing        | 41.8 mm | 28.6 mm | 9 = Race assembly (front) | 41.0 mm | 15.3 mm |
| Race assembly (rear)      | 42.1 mm | 29.1 mm | Thrust bearing            | 41.7 mm | 23.0 mm |
| 3 = Thrust bearing        | 57.3 mm | 36.3 mm | Race assembly (rear)      | 41.0 mm | 13.5 mm |
| 4 = Race assembly (front) | 58.0 mm | 43.8 mm |                           |         |         |
| Thrust bearing            | 61.7 mm | 46.0 mm |                           |         |         |
| 5 = Thrust bearing        | 88.7 mm | 72.4 mm |                           |         |         |
| 6 = Race assembly (front) | 54.0 mm | 39.0 mm |                           |         |         |
| Thrust bearing            | 57.0 mm | 39.0 mm |                           |         |         |

(front)/(rear): viewed from converter, arranged in front of or behind thrust bearing.

## Assemblies, Install in Transmission

### CLEAN

All sealing surfaces of auxiliary and main housing as well as rear cover.

### ASSEMBLE

- 1 Auxiliary housing.
- 2 Hook seal ring on journal in housing (3).
3. Ring ends are L-shaped. Press one ring end in groove, hook out the other.
4. As cut seal ring without hooks on new transmission

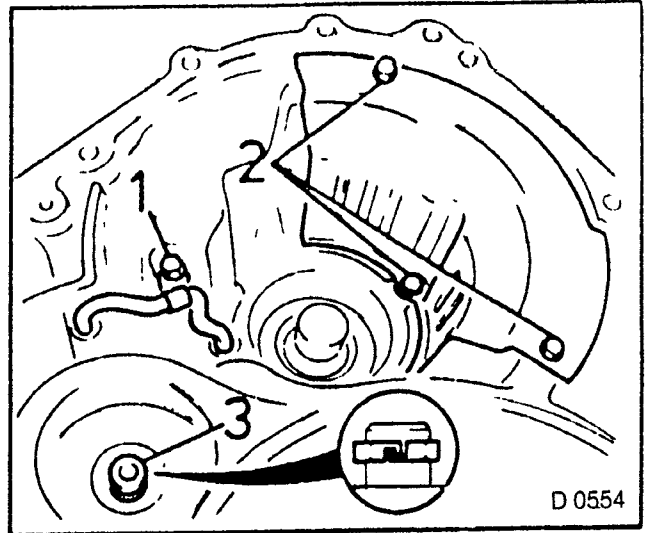


Fig 493

### TIGHTEN (TORQUE)

1. Fluid retaining plate — 6 Nm. Three bolts (Fig. 493, Item 2). Three magnets (attach to underside of fluid retaining plate).
2. Pipe clamp to fluid line (Fig. 493, Item 1) — 6 Nm.  
Press in line using plastic hammer. Do not damage.

### INSTALL, CONNECT

1. New gasket for actuation in bore on main housing (arrow) — on the housing sealing surface, located next to the differential.

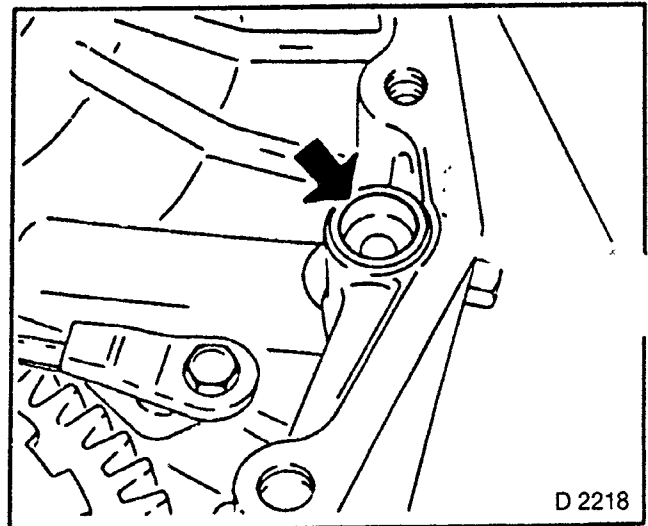


Fig. 494

### INSTALL, CONNECT

1. Needle bearing for reduction clutch.  
Drive in with KM-711-3 (1) and KM-674 (2) until tool comes to stop at main housing.

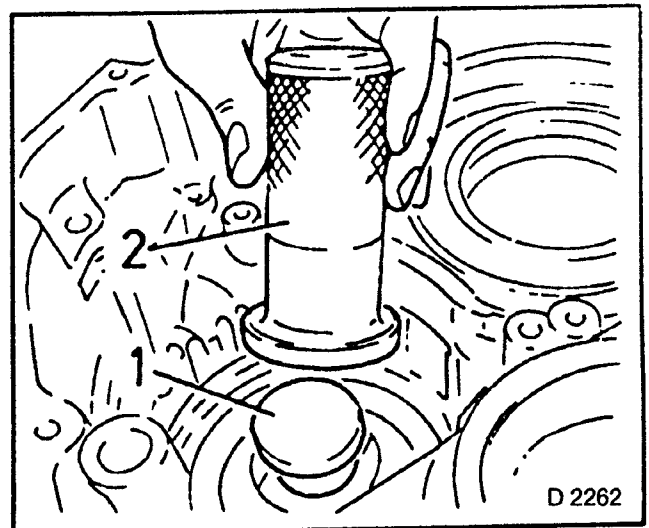


Fig. 495



2. Needle bearing for manual selector valve lever (Two pieces).
3. Place inner bearing (1) on KM-711-1 (3) and drive in as far as possible.
4. Place outer bearing (2) on KM-711-1 and drive in with inner bearing as far as possible.
5. Single-part version on new transmission — interchangeable with the previous version
6. Seal ring for shaft of toothed segment in main housing.
7. Closed side points outwards, drive in up to shoulder using suitable drift.

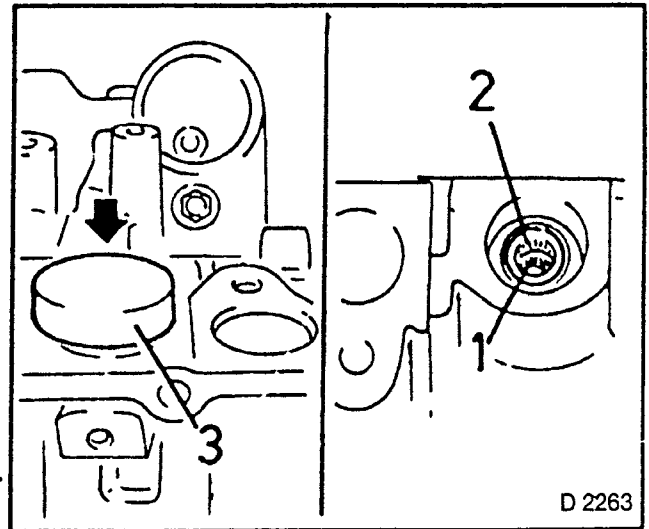


Fig. 496

## INSTALL, CONNECT

1. Roller bearing in auxiliary housing — KM-629-1.

## MEASURE

1. Installation depth of roller bearing in auxiliary housing — e.g. with steel ruler and feeler gauge. ↑
2. Press in until the upper edge of bearing protrudes 0.7 to 1.3 mm over the upper edge of housing.

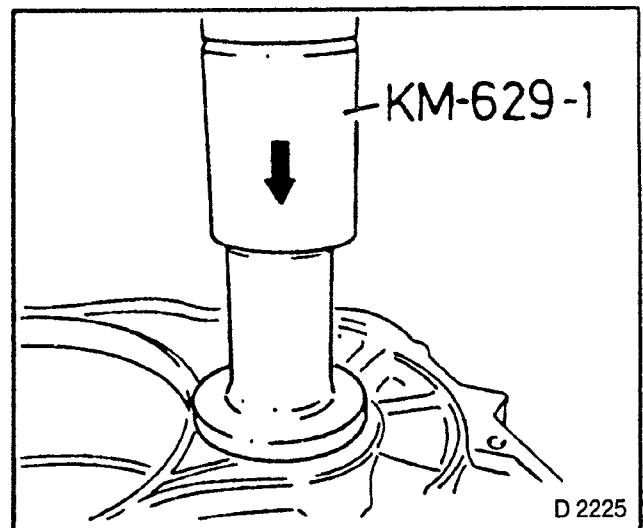


Fig. 497

## ASSEMBLE

1. Main housing.
2. Accumulator piston (6) with cover (5) and spring (4) in main housing — Fig. 498B.
3. Renew rubber O-seal rings on cover and piston.

## TIGHTEN (TORQUE)

1. Accumulator cover for reduction brake — Fig. 498A — 10 Nm.  
One Torx bolt (1).  
One bolt (2) with torsion spring no. 2 (3).
2. Snap in short leg of spring in accumulator cover.

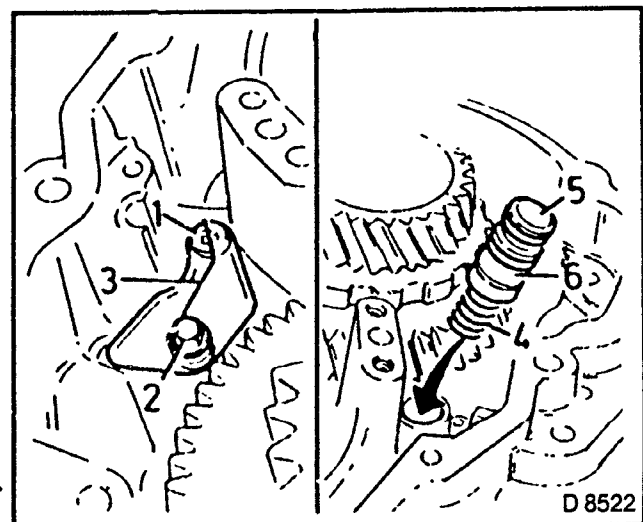


Fig. 498A

Fig. 498B

If the main housing was not renewed, some of the following parts are already installed.

### INSTALL, CONNECT

1. Two hook seal rings on journal in main housing — ring ends are L-shaped.
  2. Press one ring end in groove.
  3. Hook in the other.
- DO NOT** expand more than necessary.

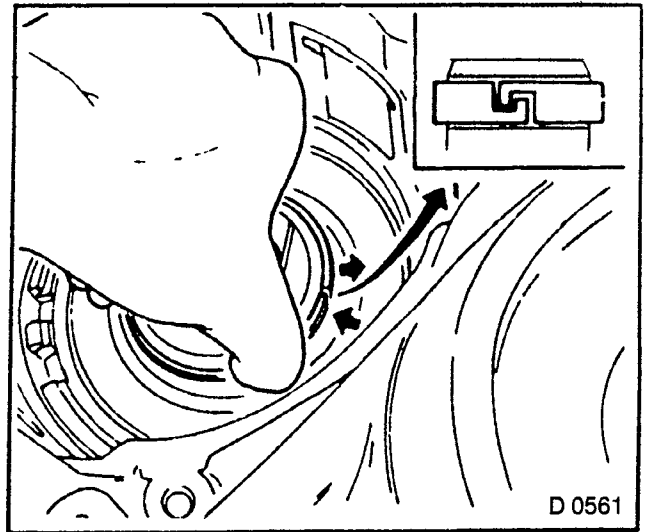


Fig. 499

2. Freewheel F3 (2).
- When removing, applied marking upwards, align lug with recesses.
3. Insert retaining ring (1).

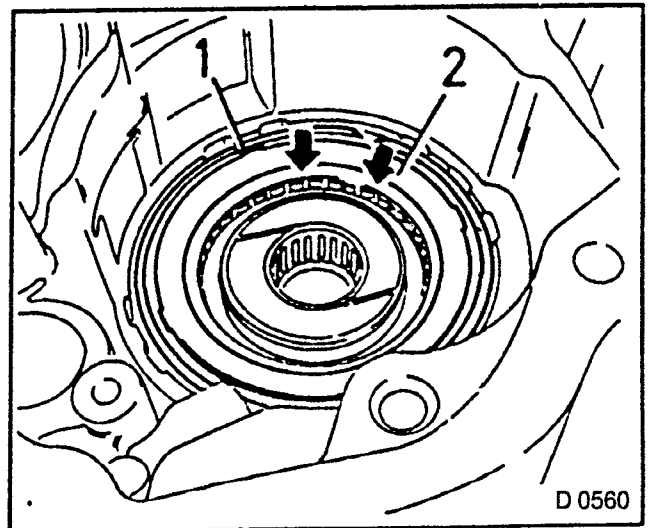


Fig. 500

### INSTALL, CONNECT

1. Piston for brake band B4 in main housing — insert piston with pressure spring and cover (1) in transmission.
2. Compress and install retaining ring (2).

**NOTE:**  
**POSSIBLY RESISTANT, COVER IS SPRING-TENSIONED.**

### INSPECT

1. Correct seating of retaining ring in groove.

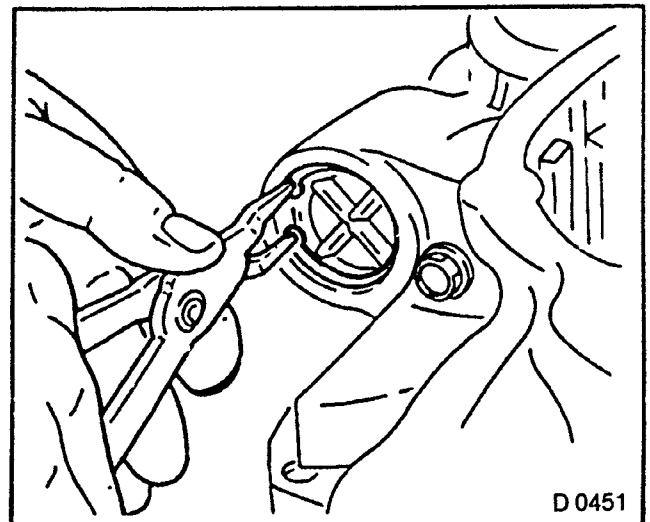


Fig. 501

**INSTALL, CONNECT**

1. Thrust bearing (2) to journal in main housing; if necessary stick on.
2. Align brake band B4 (3) with mount for anchor bolt (4) (protrudes from outside through housing).  
Place actuation centrally before piston rod (Fig. 504, Item 2).
3. Clutch body (1) — turn counter-clockwise and insert.

**INSPECT**

1. Turn at clutch body,  
Freewheel must lock clockwise.

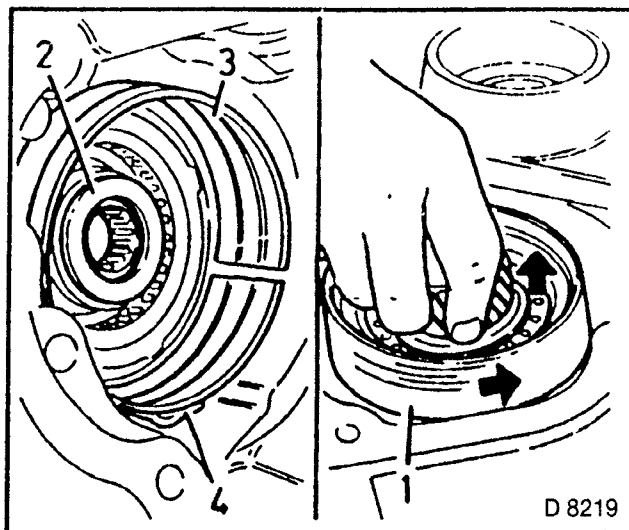


Fig. 502

**MEASURE**

1. When correctly installed, dimension 1 — upper edge of clutch body to upper edge of main housing: 78.0 to 78.5 mm

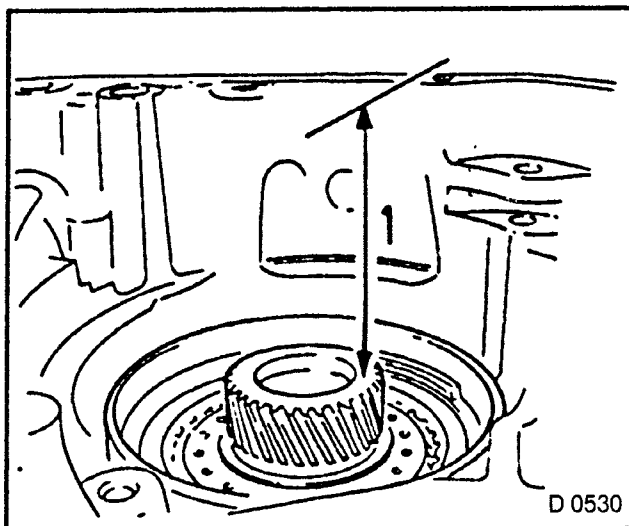


Fig. 503

**TIGHTEN (TORQUE)**

1. Anchor bolt (1) to main housing — 170 Nm.  
Note correct seating on brake band.

**NOTE:**  
ACTUATION OF BRAKE BAND (2)  
MUST BE SEATED CENTRED IN  
FRONT OF THE PISTON ROD.

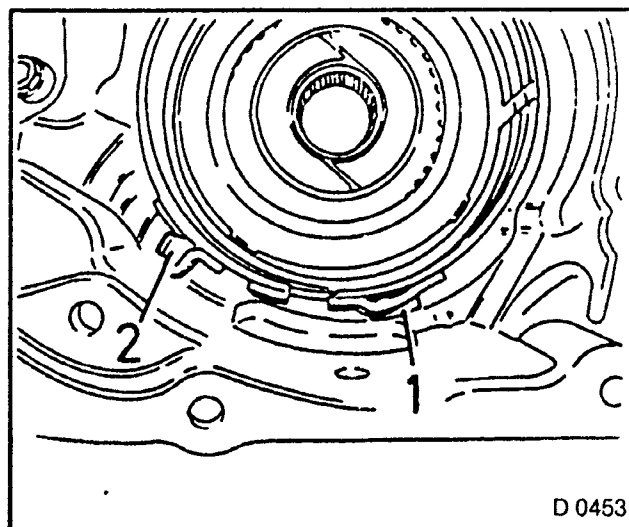


Fig 504

## INSTALL, CONNECT

1. Intermediate drive gear in main housing.
2. Insert component from converter side (arrow).
3. Insert retaining ring.

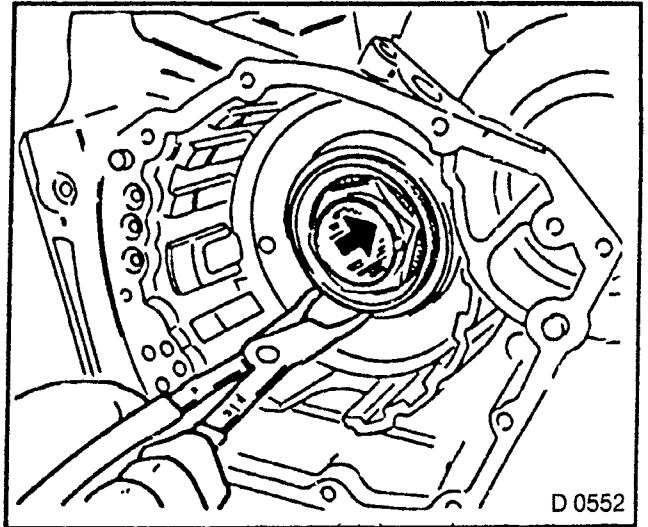


Fig. 505

4. Stick thrust bearing and race assembly (2) into internal gear. Arrangement and installation direction according to Fig. 492.
5. Planetary gear set P2 (1). Align plates of multi-plate clutch C3 with screwdriver and thread in planetary gear set P2.

## INSPECT

1. Correct turnability of intermediate drive gear and drive gear (driving) — splines of both align when correctly installed.

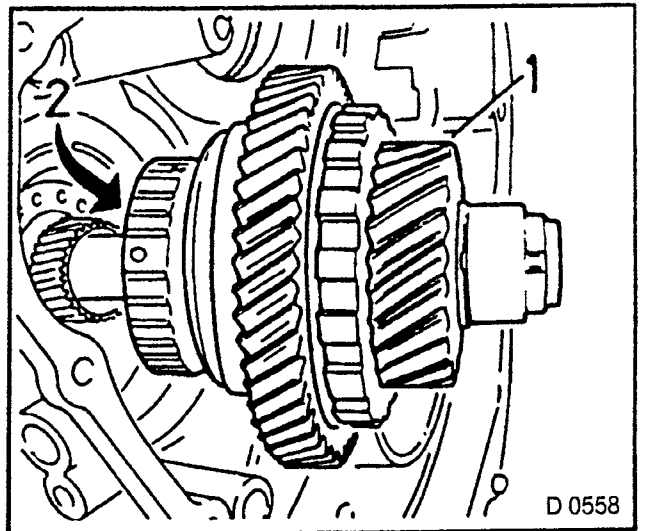


Fig. 506

## TIGHTEN (TORQUE)

1. Pipe main pressure no. 2 (2) — press in line with plastic hammer. **DO NOT** damage. Tighten pipe clamp — 7 Nm.
2. Fluid retaining plate (1) to main housing (next to planetary gear set P2) — 7 Nm.

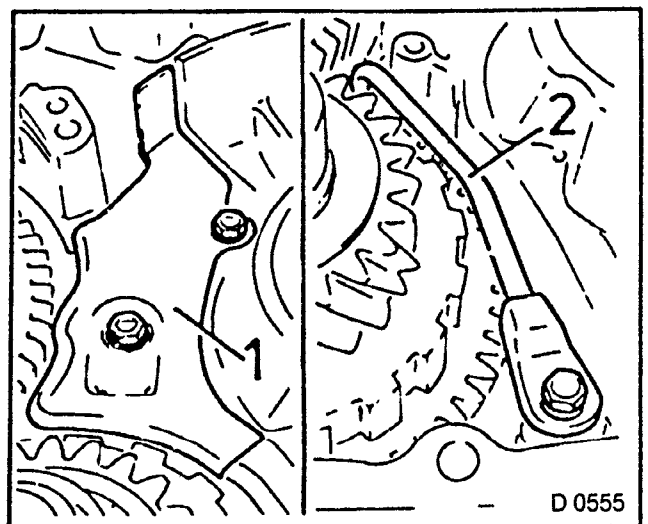


Fig. 507

**INSTALL, CONNECT**

1. Parking pawl assembly
2. Slide in pin for parking pawl (1) at main housing — up to stop.

**TIGHTEN (TORQUE)**

1. Cam plate (2) and lock spring (3) to main housing (arrows) — 10 Nm.  
Guide end of lock spring through opening in main housing to installation position of ratchet.  
Initially tighten only one bolt, so that ratchet can be mounted.

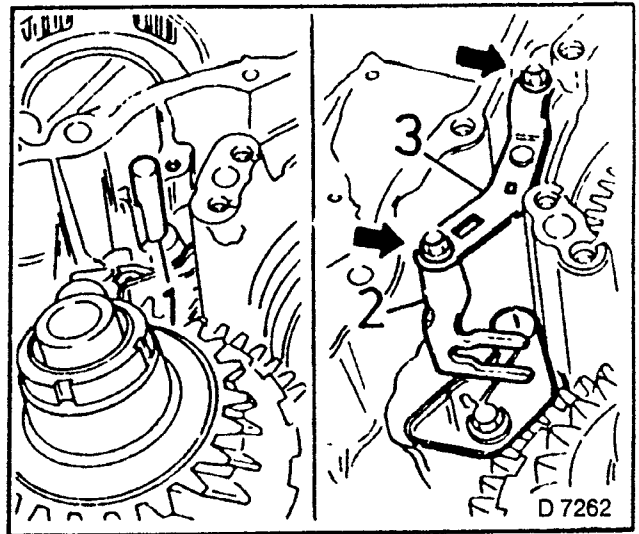


Fig. 508

**INSTALL, CONNECT**

1. Pawl for parking pawl (1) at mount in main housing as well as at cam plate and torsion spring no. 2 (2)
2. Axle for parking pawl and spring no. 1 (3) from above in mount in main housing. Short spring end to housing inner wall, long spring end to pawl for parking pawl (1).  
Spring no. 1 keeps pawl away from parking lock wheel.

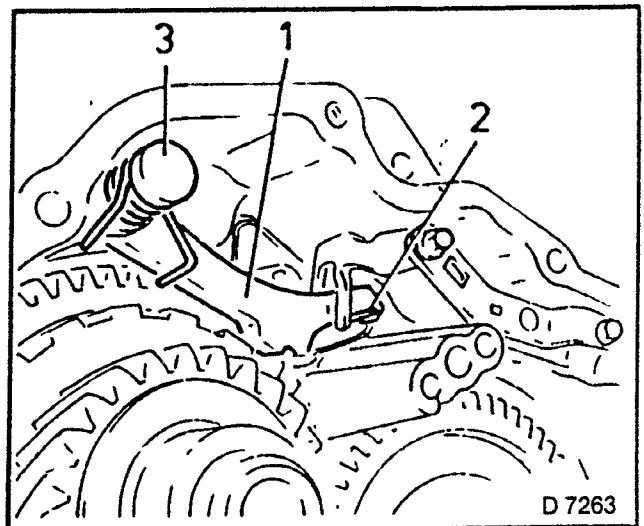


Fig. 509

**INSTALL, CONNECT**

1. Guide actuation rod for parking pawl (1) through opening in main housing to parking pawl assembly. Angular end is guided through between ratchet (Fig. 511, Item 2) and housing wall.
2. Insert the shouldered end of the actuation rod between the cam plate (2) and pawl (3).

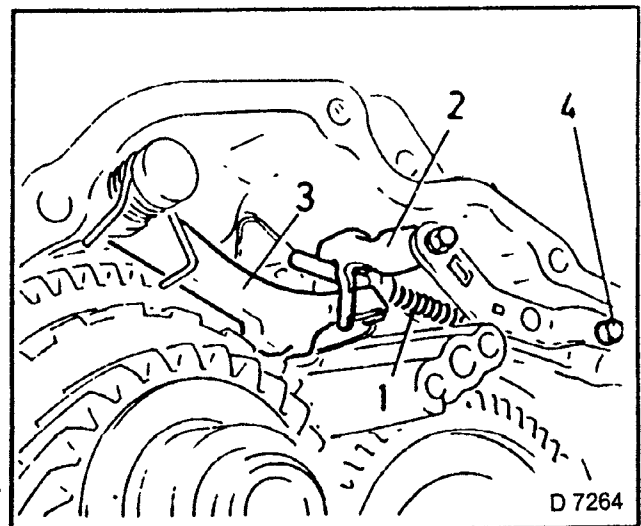


Fig. 510

3. Drive in new seal ring (1) with suitable sleeve.
4. Ratchet (2) at main housing.
5. Insert actuation rod (3) in ratchet (2).  
Align lugs at the rod and recesses at the ratchet by turning ratchet.

### TIGHTEN (TORQUE)

1. Lock spring to main housing (Fig. 510, Item 4).  
Tighten the second bolt — 10 Nm.
2. Lock spring (4) must actuate ratchet (2) at the centre.

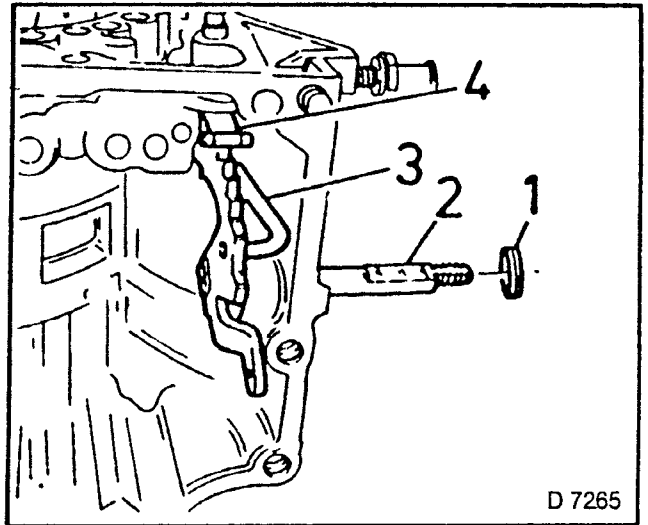


Fig. 511

3. Lock main housing horizontally to bracket.

### INSTALL, CONNECT

1. Differential in main housing (Fig. 513, Item 2).  
Observe centering pin (arrow) (Fig. 512).

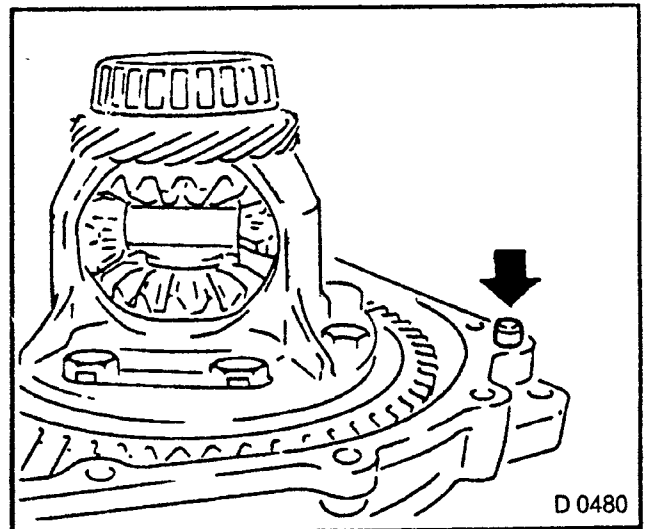


Fig. 512

### TIGHTEN (TORQUE)

1. Plate of main housing (4) — 7 Nm, two bolts.
2. Fluid screen (3) — 7 Nm, one bolt.
3. Coat sealing surface with Sealing Compound (Loctite 242).
4. Auxiliary housing to main housing, fifteen bolts (1) — 30 Nm.

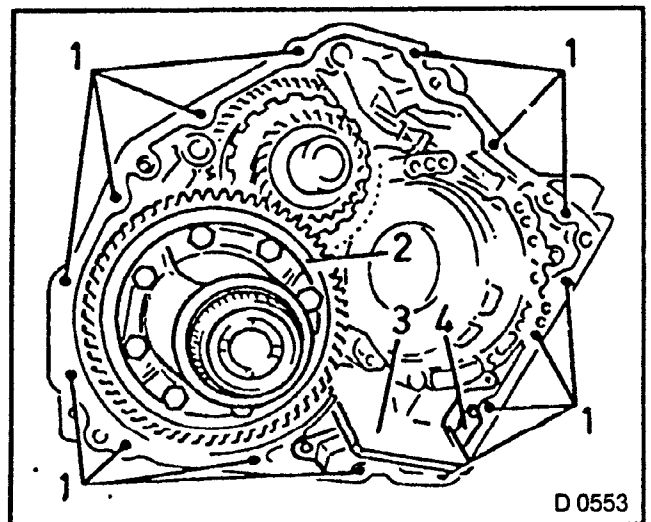


Fig. 513

**TIGHTEN (TORQUE)**

1. Drain plug (1) — 35 Nm.  
Clean magnetic surfaces.  
Use new gasket.

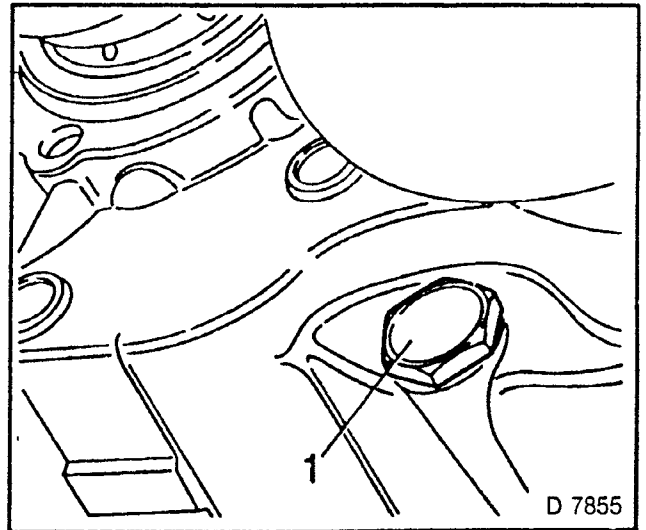


Fig 514

**INSTALL, CONNECT**

1. Piston of multi-disc brake B3 in transmission.
2. Press in piston with new rubber O-seal rings on intermediate drive gear nut side.
3. Spring mount points upwards.

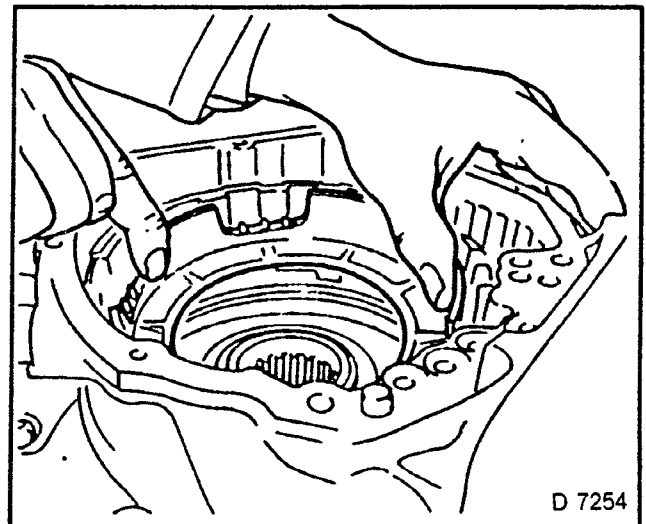


Fig. 515

**INSTALL, CONNECT**

1. Return spring assembly (1) on piston B3.
2. Insert in spring mount.
3. Insert retaining ring.

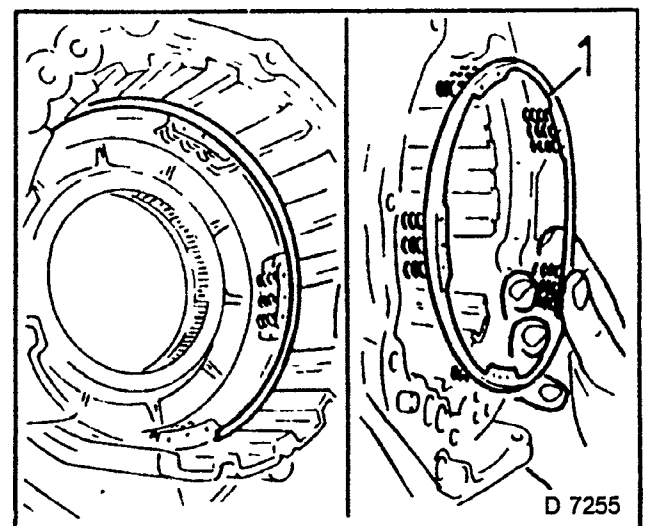


Fig. 516

### INSTALL, CONNECT

1. Front internal gear assembly (with freewheel F2) through aperture for rear cover in transmission.
2. Stick thrust bearing and race assembly to underside (arrangement and installation direction according to Fig. 492).

### INSPECT

1. Front internal gear must be turnable counter-clockwise.

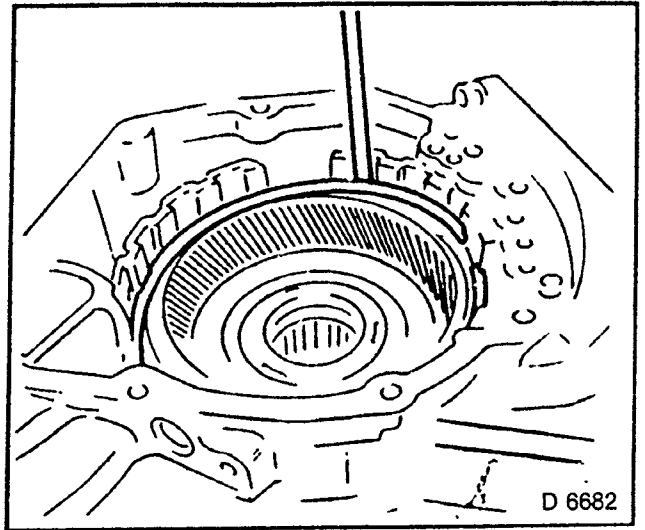


Fig. 517

### INSTALL, CONNECT

1. Plate packet B3 in transmission.
2. Alternately steel plates (Five pieces). Lining plates (Five pieces). Lastly, flange.
3. Align lugs of steel plates with recesses in transmission.
4. Insert retaining ring.

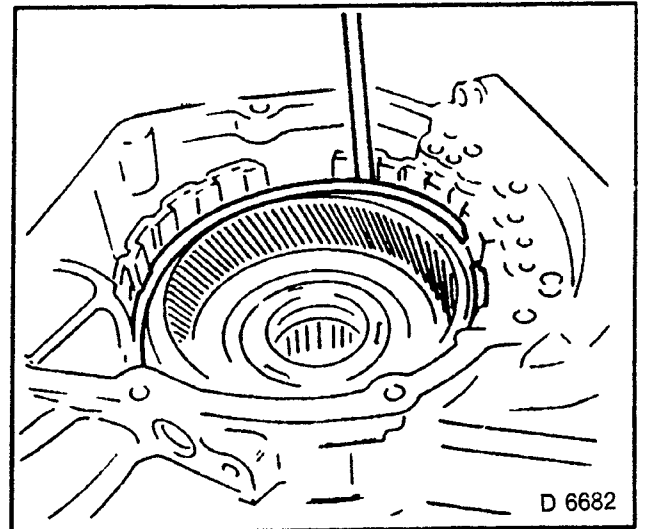


Fig. 518

### MEASURE

1. Piston stroke of multi-disc brake B3 — with gauge.
2. Place probe on piston floor. Blow in compressed air (4 bar, arrow), value 1.75 to 2.55 mm.
3. Play between piston and plate packet — with feeler gauge. Measurement value: 0.61 to 1.89 mm.

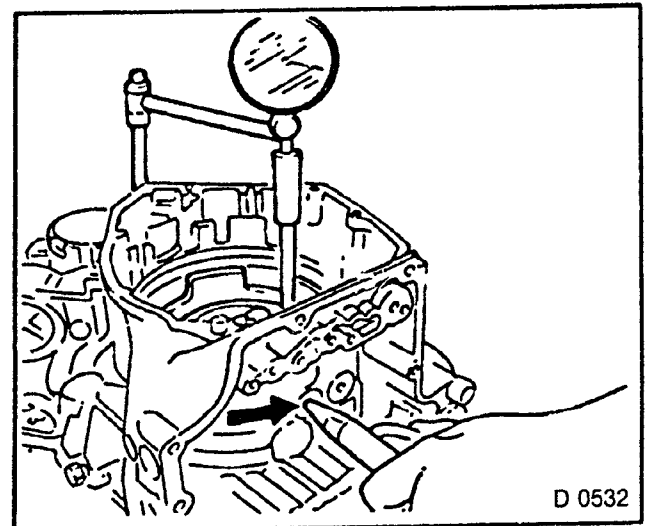


Fig. 519



**INSTALL, CONNECT**

1. Planetary gear set P1 in transmission — Insert through aperture for rear cover in front internal gear.
2. Stick thrust bearing to underside of planetary gear set P1. Arrangement and installation direction according to Fig. 492. Correctly thread planetary gears.

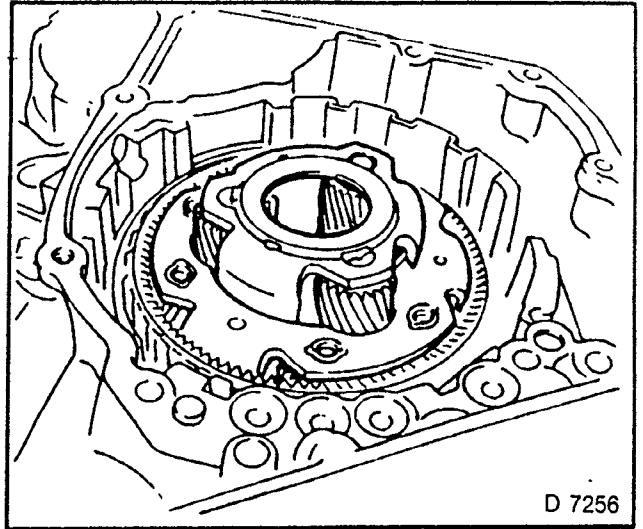


Fig. 520

3. Rear internal gear on planetary gear set P1.
4. Stick thrust bearing to underside of rear internal gear. Arrangement and installation direction according to Fig. 492.

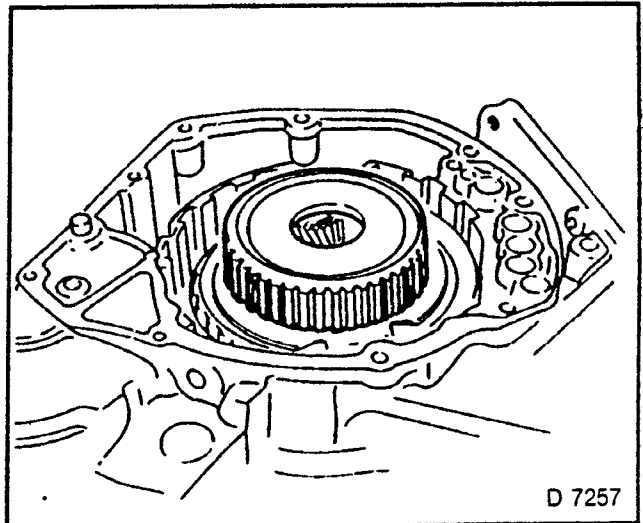


Fig 521

**INSTALL, CONNECT**

1. Sun gear to planetary gear set P1.
2. Stick thrust bearing to underside of sun gear. Arrangement and installation direction according to Fig. 492.
3. Insert sun gear in planetary gear set P1.

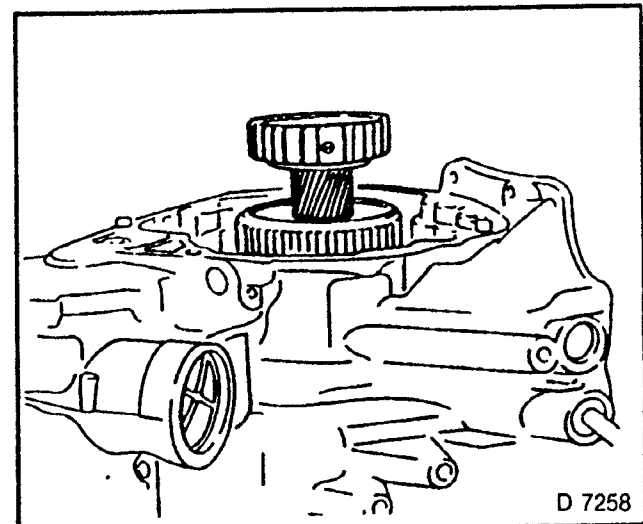


Fig. 522

**MEASURE**

1. When installed correctly, dimension (1) — sun gear inner surface to main housing upper edge — values 31.0 to 32.0 mm.

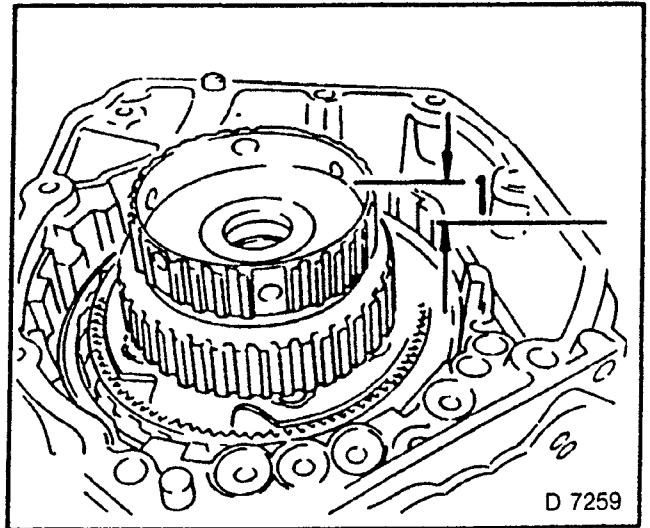


Fig. 523

**INSTALL, CONNECT**

1. Drive shaft assembly (with multi-plate clutch C1 and C2) in transmission.
2. Align lining plates C1 and C2 with screwdriver and thread in sun gear or rear internal gear.

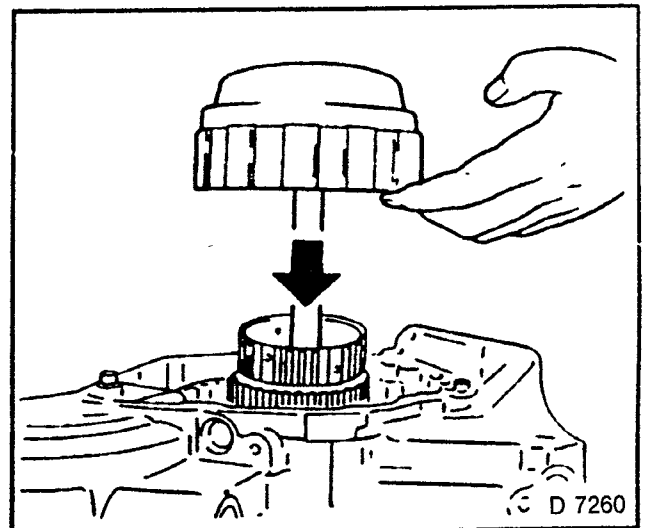


Fig. 524

**MEASURE**

1. When installed correctly, dimension (1) — drive shaft upper edge to main housing upper edge — value 51.3 to 52.3 mm.

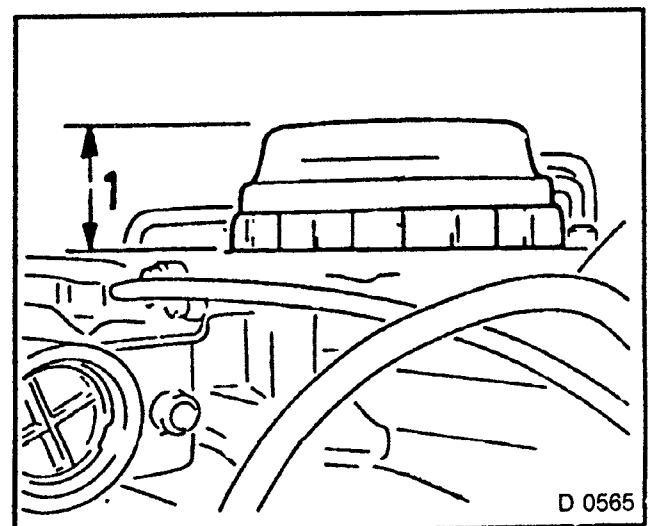


Fig. 525

**INSTALL, CONNECT**

1. Three actuation pipe lines in transmission.
2. Drive in affected bores in aperture for rear cover with plastic hammer. Do not damage.

**TIGHTEN (TORQUE)**

1. Pipe clamp to transmission — 7 Nm.

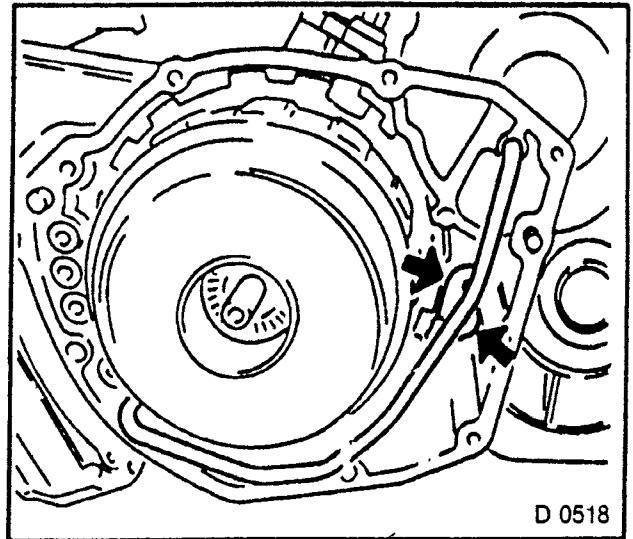


Fig. 526

**INSTALL, CONNECT**

1. Cement four gaskets for fluid circuit regulator to transmission (Fig. 527B) — in the bore holes at the sealing surface for the rear cover.

**TIGHTEN (TORQUE)**

1. Rear cover to transmission (Fig. 527A) — M 8: 25 Nm, M 6: 10 Nm.
2. Clean sealing surface of rear cover.
3. Blow dry and insert with Sealing Compound (Locktite 242).
4. Check centering pins.

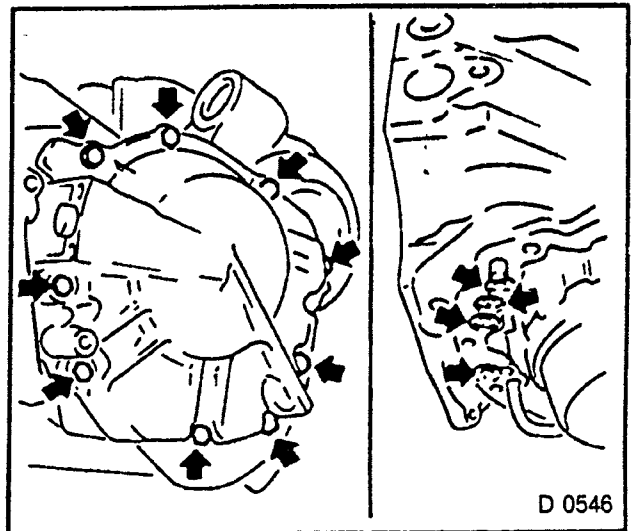


Fig. 527A

Fig. 527B

**INSTALL, CONNECT**

1. Freewheel F1 in fluid pump
2. Align lining plates B1 and B2 with screwdriver, so that freewheel can be installed.

**MEASURE**

1. When installed correctly, dimension 1 (upper edge of fluid pump plate to upper edge of freewheel) has value 51.1 to 51.7 mm.

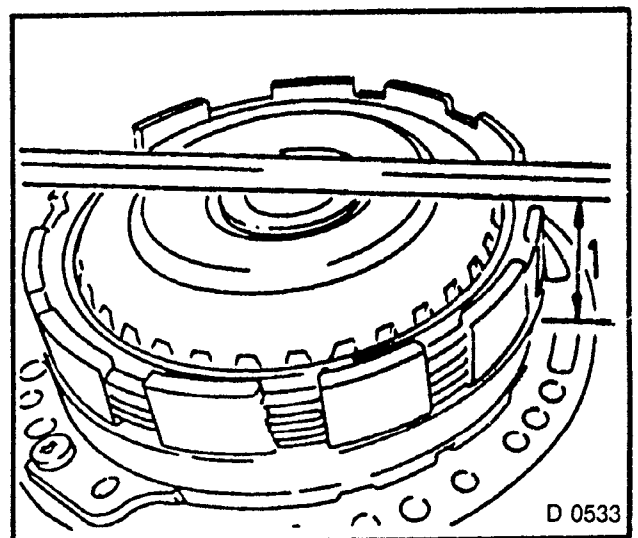


Fig. 528

D 0533

**NOTE:**

Before installation of fluid pump, protruding drive shaft must show a small amount of play. Fix transmission horizontally.

**TIGHTEN (TORQUE)**

1. Fluid pump to transmission — 25 Nm.  
Fig. 529 shows removal.  
Note hole alignment position, asymmetrical version.  
If necessary, fluid pump can be aligned in bore thread by turning counters (arrows).

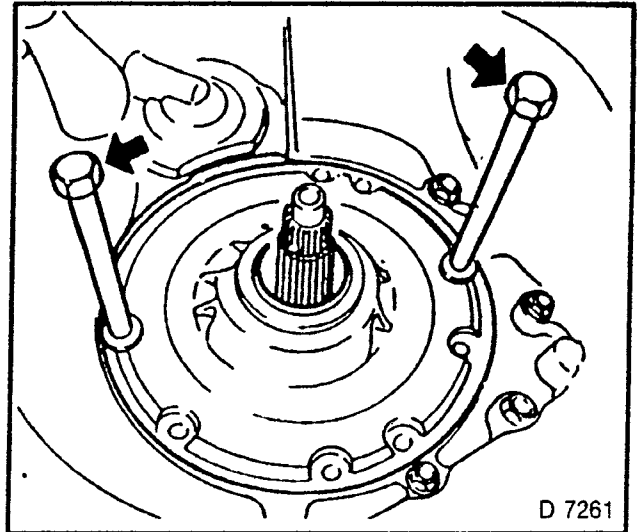


Fig. 529

**MEASURE**

1. Axial play of drive shaft — with gauge.  
Measurement value 0.37 to 0.90 mm.

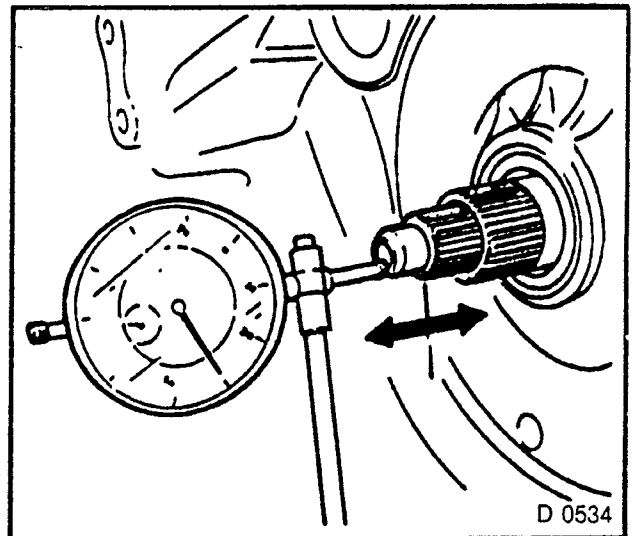


Fig. 530

**INSTALL, CONNECT**

1. Stick two gaskets for actuation (2) to transmission.
2. Manual selector valve with connecting rod (1) in valve body.

**INSPECT**

1. Play — free seating in valve body.

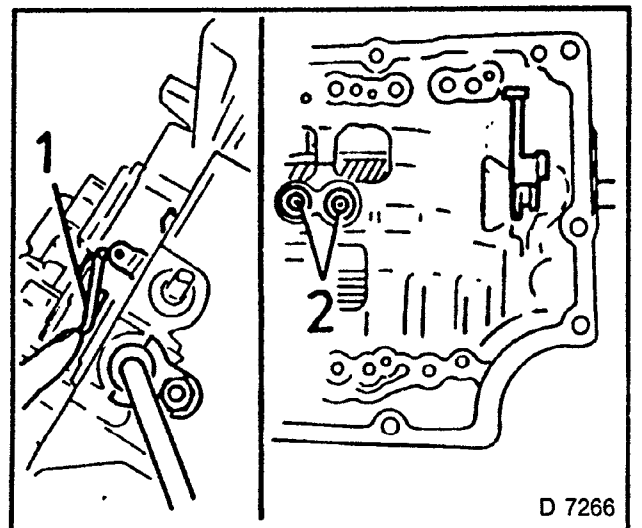


Fig. 531

**INSTALL, CONNECT**

1. Valve body to transmission
2. Connecting rod (1) to ratchet (2)

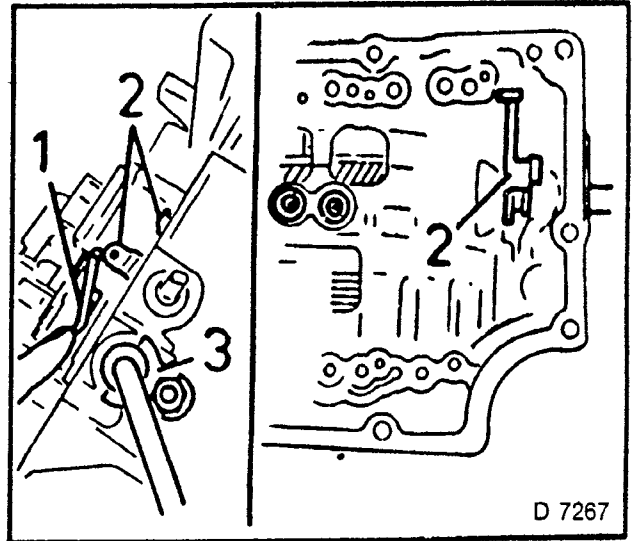


Fig. 532

**TIGHTEN (TORQUE)**

1. Valve body (3) — Seven bolts. Intake cover with new gasket (2) — two bolts — 10 Nm.
2. Solenoid valve wiring harness (1) — guide four wiring harness plugs from outside through bore in transmission.
3. Retaining plate — 13 Nm.

**INSTALL, CONNECT**

1. Four wiring harness plugs (1) for solenoid valves/fluid pressure regulator (different cable lengths).
2. Insert cables in retaining clamps.

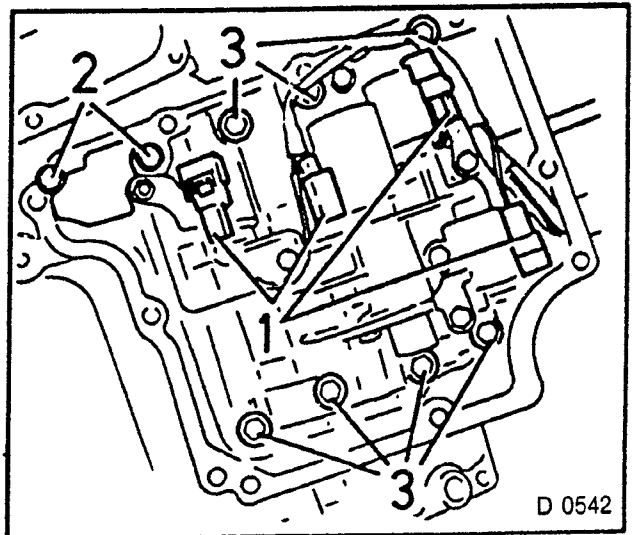


Fig. 533

**TIGHTEN (TORQUE)**

1. Side cover to transmission — 25 Nm. **DO NOT** yet turn two bolts for cover plate of fluid temperature sensor.
2. Insert side cover with Sealing Compound (Locktite 242).

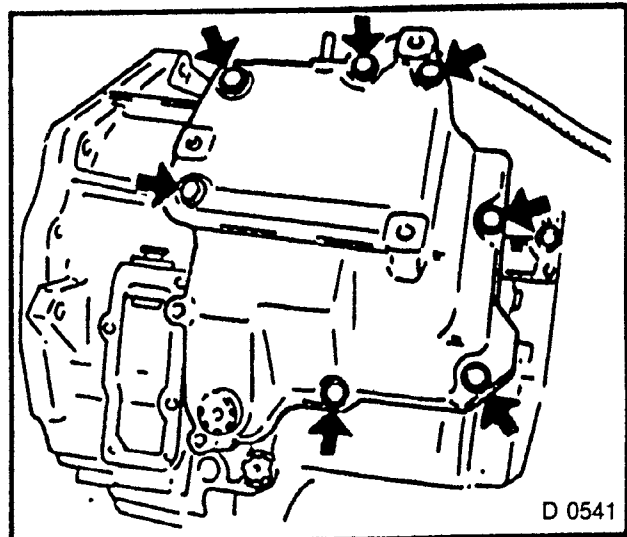


Fig. 534

3. Auxiliary housing cover (2) — 5 Nm.
4. Insert cover with Sealing Compound.
5. Fluid temperature sensor (1) — 25 Nm.  
Use new gasket.
6. Cover plate of fluid temperature sensor (arrows) — 25 Nm.

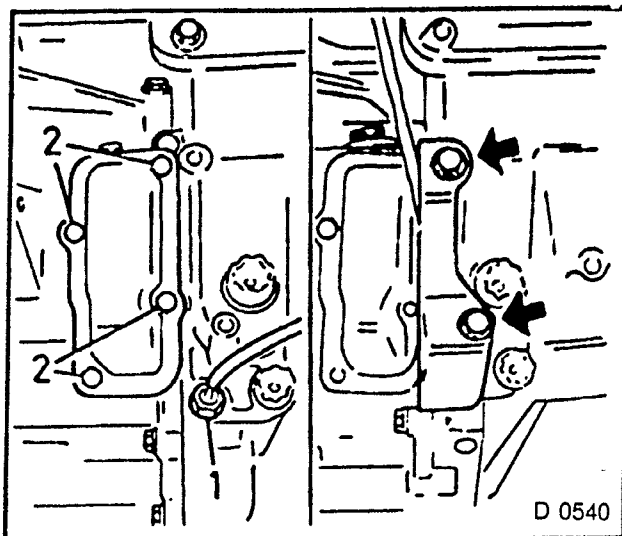


Fig. 535

### TIGHTEN (TORQUE)

1. Eleven plugs with new seal rings to transmission.  
Seven plugs — M 8 (1) — 8 Nm.  
One plug — M 14 (2) — 35 Nm.  
One plug — M 18 Torx (3) — 35 Nm.  
Two plugs — M 20 (4) — 35 Nm.

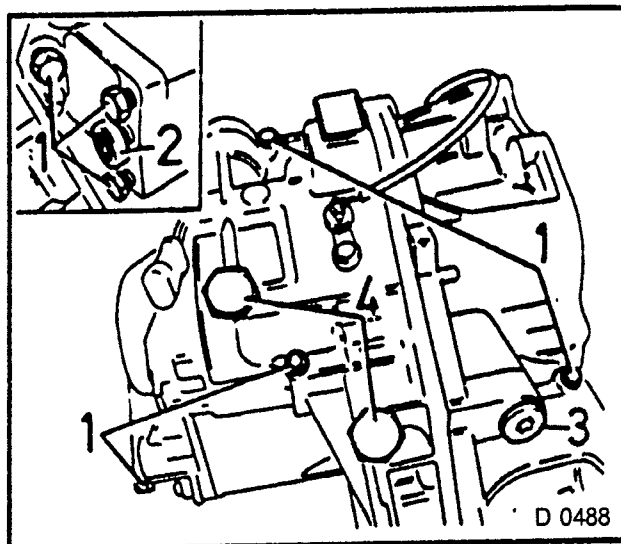


Fig. 536

2. Sensor for transmission input speed (1) — 6 Nm.
3. Sensor for transmission output speed (2) — 6 Nm.

### INSTALL, CONNECT

1. Fluid filler pipe to transmission.  
Press in with new seal ring up to offset.

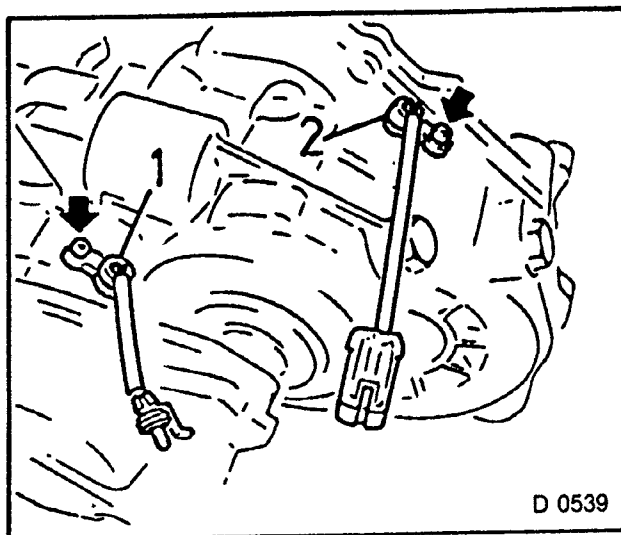


Fig. 537

**ADJUST**

1. Position of selector lever position switch relative to transmission.
2. Place switch from above on selector lever shaft (1).
3. Selector lever shaft or actuation lever Fig. 539 Item 3 in neutral position — up to stop to the right, then turn back two notches (P, R, N — see Fig. 538).
4. Turn selector lever position switch so that the flattened surface of the selector lever shaft (arrows) runs parallel to the split (2) on the housing of the switch.
5. In this position, tighten the selector lever position switch to the transmission (3).

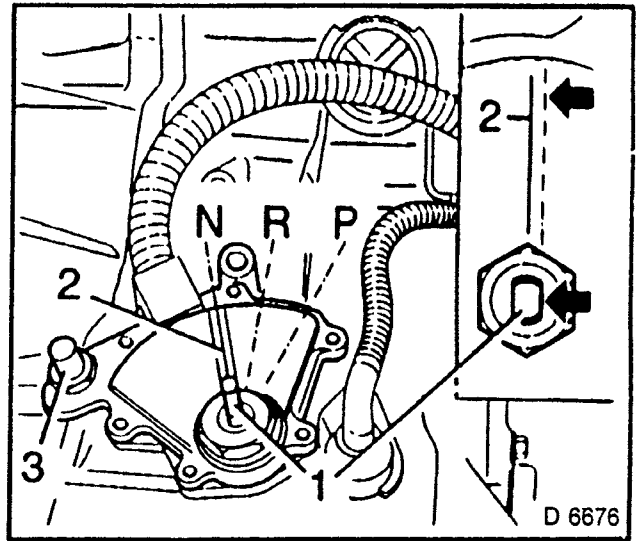


Fig. 538

**TIGHTEN (TORQUE)**

1. Neutral switch and fluid filler pipe to transmission (arrow, left) — 25 Nm.
2. Selector lever position switch to selector lever shaft — nut (1) — 8 Nm. Secure with locking plate (arrow, right).
3. Actuation lever (3) to selector lever shaft (2) — 16 Nm.
4. Counterhold selector lever shaft at actuation lever with pliers.
5. Speedometer gear (driven) with retaining plate to transmission — 4 Nm.

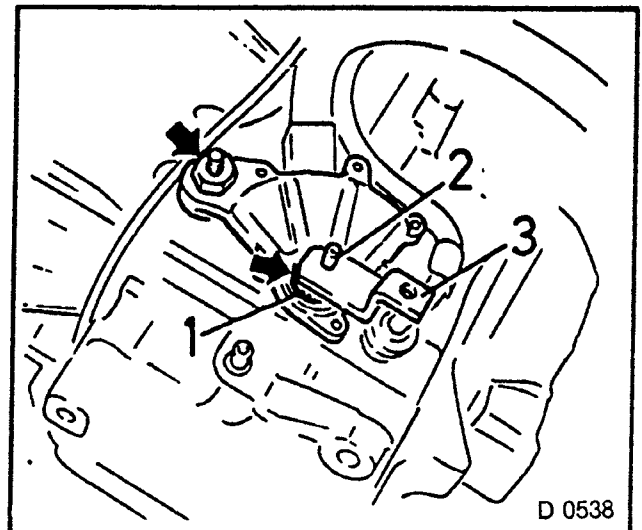


Fig. 539

**INSTALL, CONNECT**

1. Converter in transmission.
2. Transmission.
3. Fill with transmission fluid.

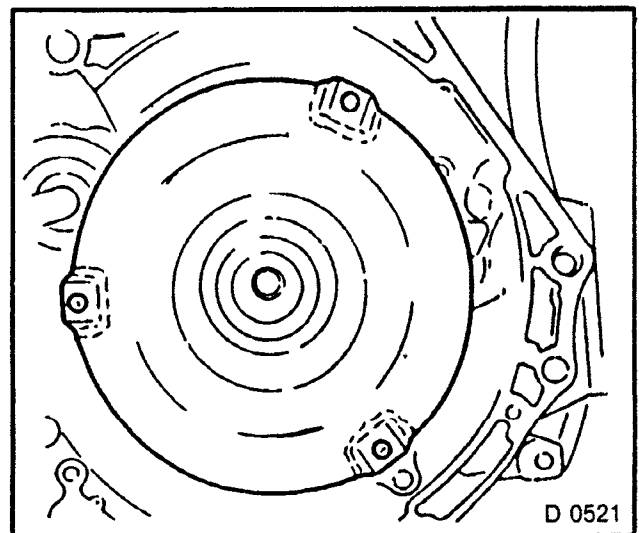


Fig. 540

## SPECIAL SERVICE TOOLS

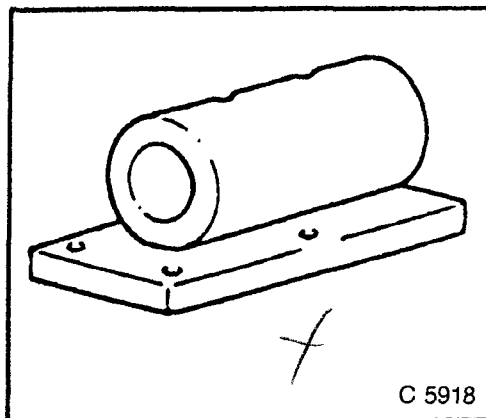
### Clutch, Manual Transmission and Differential

#### KM-113-2 TRANSMISSION BASE

(in conjunction with KM-552, KM-489)  
Mount for transmission bracket  
F 10, F 13, F 16, F 20 manual transmission.

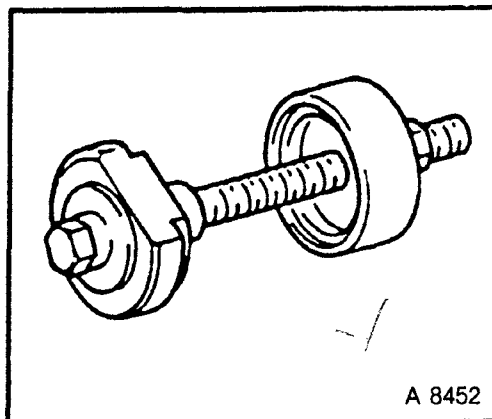
To hold transmission when overhauling  
with KM-694

**AUTOMATIC TRANSMISSION AF 20.**



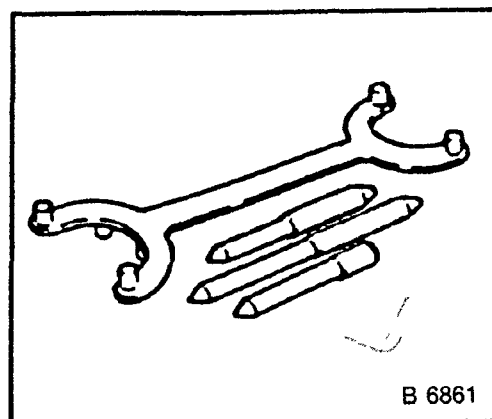
#### KM-120 REMOVER/INSTALLER

(in conjunction with KM-451)  
To insert tapered roller bearing outer ring  
F 10 and F 13 manual transmission.



#### KM-160-4 CENTERING BOLT

To pre-assemble differential  
F 16, F 20 manual transmission.



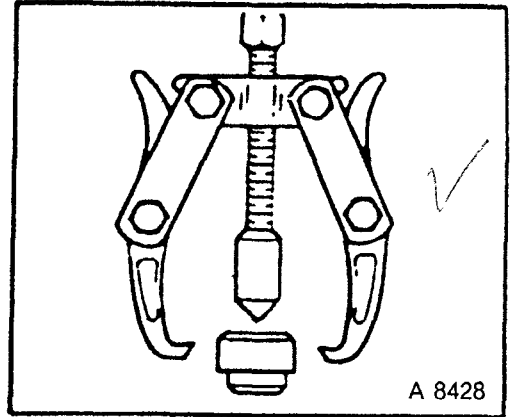


**KM-161-A BEARING PULLER**

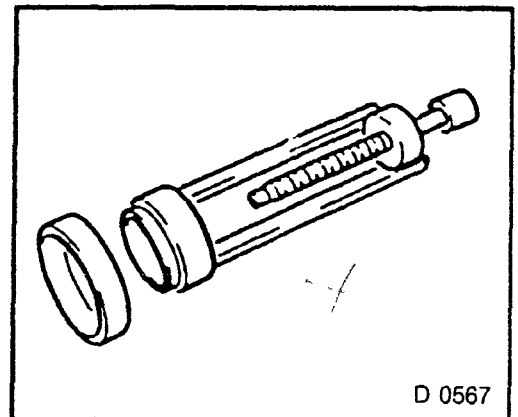
F 10, F 13, F 16, F 20 manual transmission.  
 To remove both tapered roller bearing inner races from differential housing.  
 Use Hook -3 and Thrust Pad -4.  
 To remove 5th gear synchronesh body from main shaft.  
 Use Hook -2.

To pull both tapered roller bearing inner races from differential housing with hooks -3 and Thrust Plate KM-403.

**AUTOMATIC TRANSMISSION AF 20.**

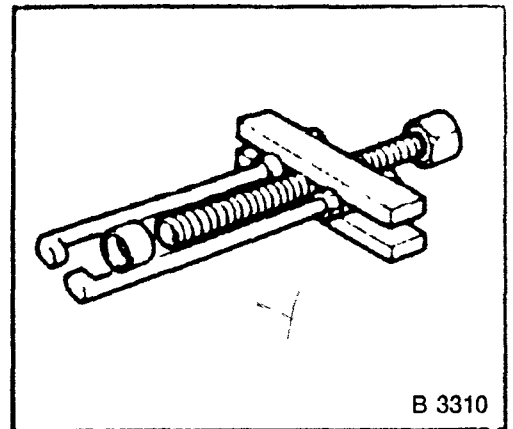
**KM-171 BEARING REMOVER**

To remove rear tapered roller bearing from planetary gear set P2 with KM-528.  
**AUTOMATIC TRANSMISSION AF 20.**

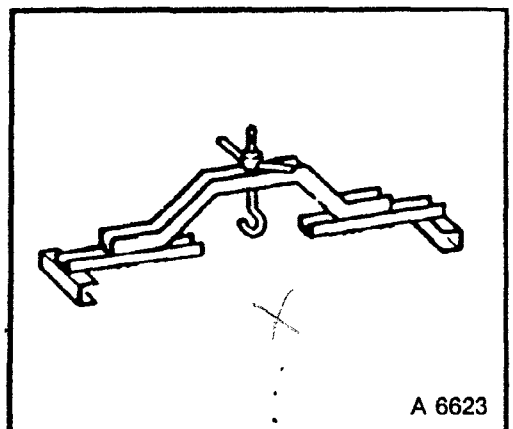
**KM-210-A WHEEL PULLER**

To pull both tapered roller bearing outer races from transmission housing with KM-709.

**AUTOMATIC TRANSMISSION AF 20.**

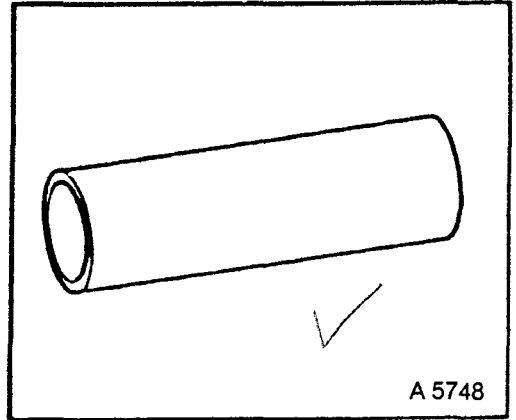
**KM-263-A ENGINE LIFTER**

F 10, F 13, F 16, F 20 manual transmission.  
 To suspend engine with commercially available spring hook.



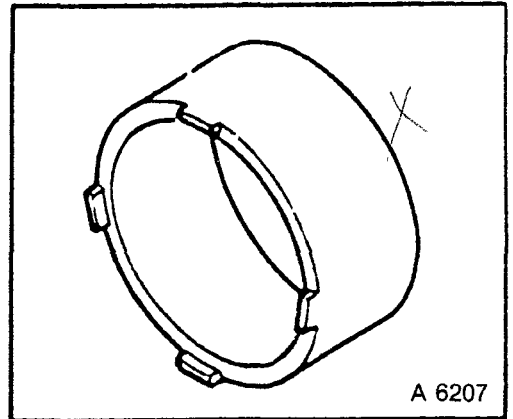
**KM-277 BEARING INSTALLER**

F 10, F 13 manual transmission  
To press on 3rd and 4th gear synchronizer body assembly.



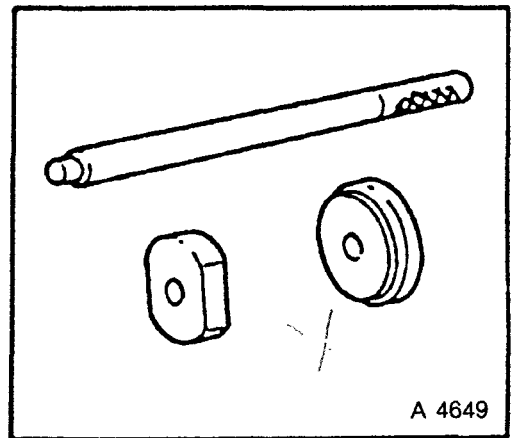
**KM-303 INSTALLER SLEEVE**

F 10, F 13 manual transmission.  
Place sleeve underneath while knocking tapered roller bearing outer races out of bearing ring.



**KM-304 REMOVER/INSTALLER**

F 10, F 13, F 16, F 20 manual transmission.  
To knock out tapered roller bearing outer race from transmission in conjunction with KM-451. Place KM-502-A underneath.

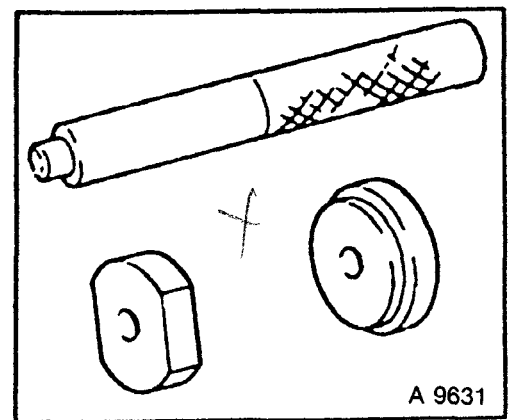


**KM-305 REMOVER/INSTALLER**

F 10, F 13, F 16, F 20 manual transmission.  
To remove and install tapered roller bearing outer races from transmission, bearing flange and bearing ring. In conjunction with KM-303 and KM-451.

To remove and install various bearings in transmission with KM-695.

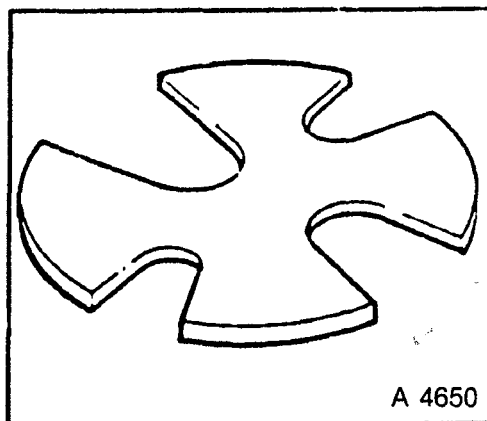
**AUTOMATIC TRANSMISSION AF 20.**



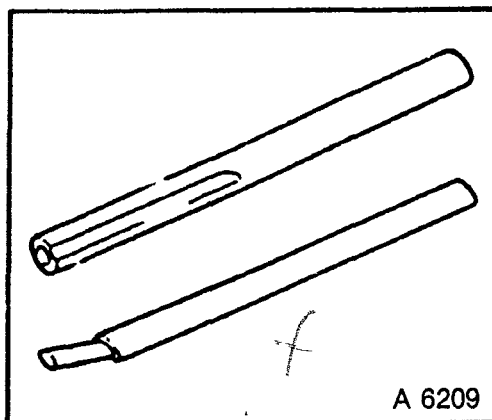
**KM-307-B REMOVER PLATE**

F 10, F 13, F 16, F 20 manual transmission.  
To press off 1st and 2nd gear synchromesh body and also 2nd gear

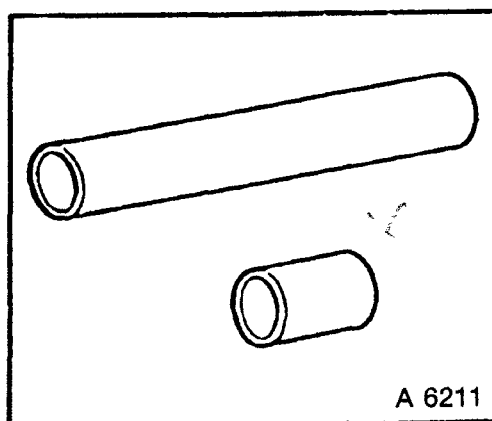
F 10, F 13 manual transmission.  
Press off drive gear (driving) from main shaft.

**KM-308 REMOVER/INSTALLER**

F 10, F 13, F 16, F 20 manual transmission.  
To drive in and out pins for shift rod and gearshift lever shaft.

**KM-311 INSTALLER**

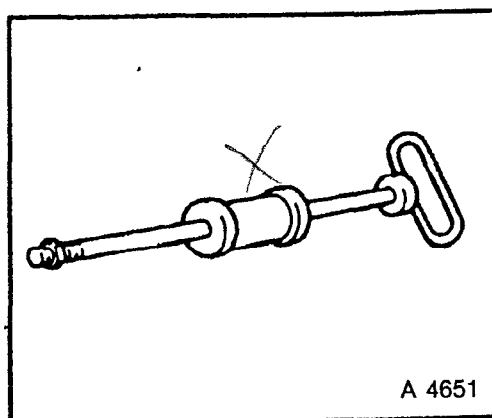
F 10, F 13, F 16, F 20 manual transmission.  
To press on spacing washer, ball bearing and synchromesh body on main shaft.  
No longer available.

**KM-313 SHAFT REMOVER**

F 16, F 20 manual transmission.  
To remove outer sleeve for main shaft bearing from transmission housing in conjunction with KM-483 and KM-J-26941.

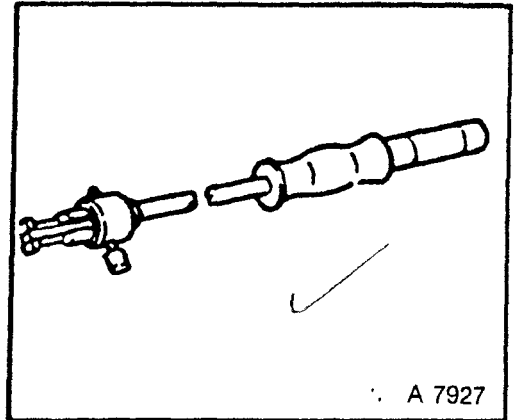
To knock roller bearing out of auxiliary housing with KM-J-26941 and KM-483.

**AUTOMATIC TRANSMISSION AF 20.**

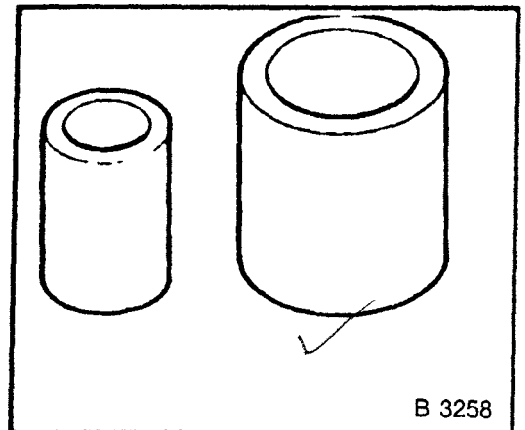


**KM-328-B REMOVER**

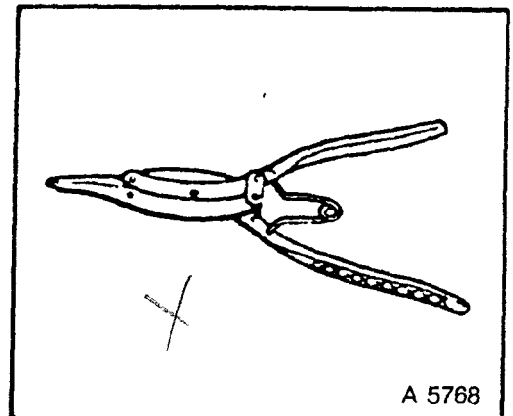
F 10, F 13, F 16, F 20 manual transmission.  
To knock out plug for shifting lock from  
end shield in conjunction with KM-727

**KM-334 INSTALLER**

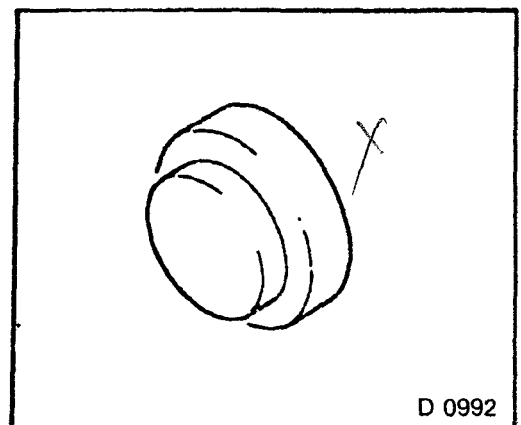
F 10, F 13, F 16, F 20 manual transmission.  
To press on spacing washer on main shaft.

**KM-396 RING PLIERS**

To remove and install retaining ring in  
clutch body.  
**AUTOMATIC TRANSMISSION AF 20.**

**KM-403 THRUST PLATE**

To remove tapered roller bearing inner race  
from differential with KM-161-A.  
**AUTOMATIC TRANSMISSION AF 20.**



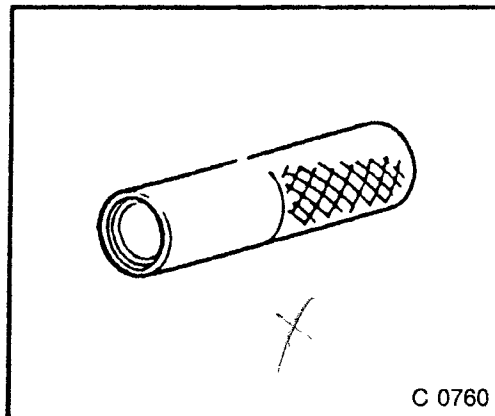
**KM-407-A RING INSTALLER**

F 16, F 20 manual transmission.

To remove the gear block ball bearing.

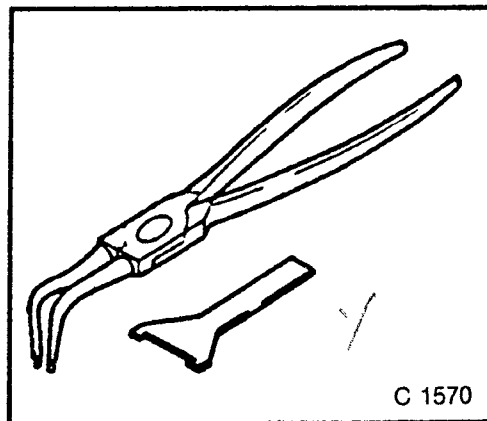
To press out driven intermediate gear from planetary carrier with KM-701

**AUTOMATIC TRANSMISSION AF 20.**

**KM-443-A RING PLIERS****KM-443-B RING PLIERS AND ASSEMBLY AID**

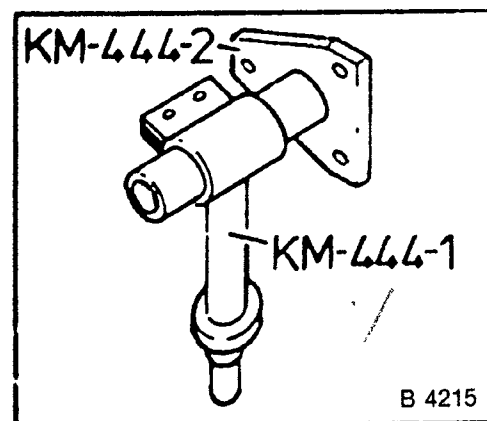
F 10, F 13, F 16, F 20 manual transmission.

To remove both retaining rings for main shaft and drive shaft attachment.

**KM-444-B HOLDING FIXTURE**

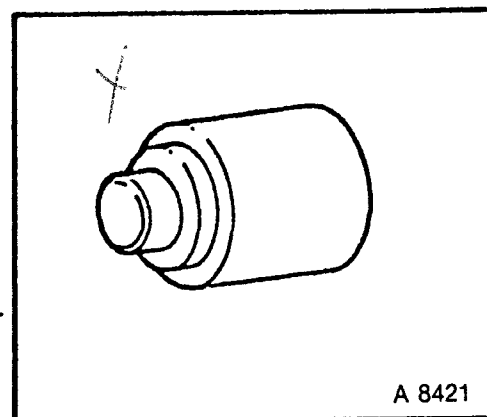
KM-444-2 to hold transmission during overhaul operation with Fixture Base KM-489.

KM-444-B consists of KM-444-1 and KM-444-2, for removal and installation of transmission.

**KM-445 SEAL INSTALLER**

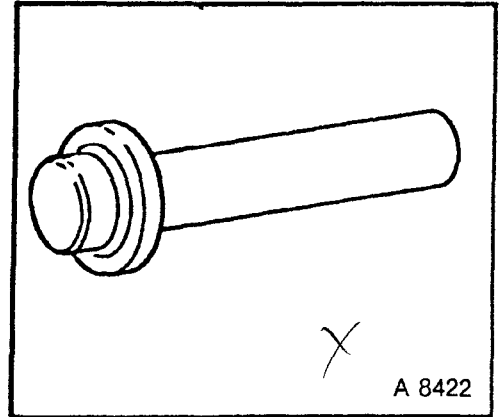
F 10, F 13 manual transmission.

To install new seal ring in thrust bearing guide.

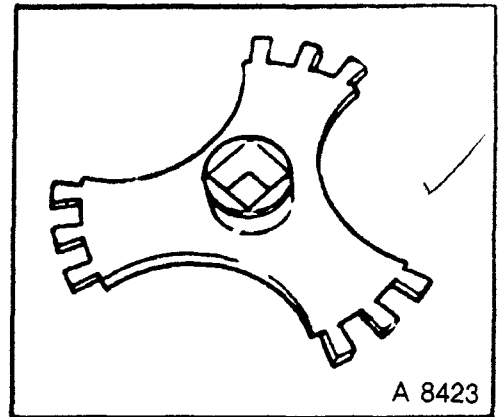


**KM-446 SEAL INSTALLER**

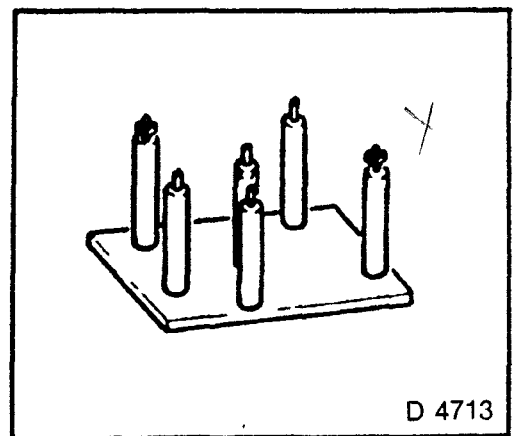
F 10, F 13 manual transmission.  
To drive in flush both seal rings for axle shafts in bearing ring and also in transmission.

**KM-447 REMOVER/INSTALLER**

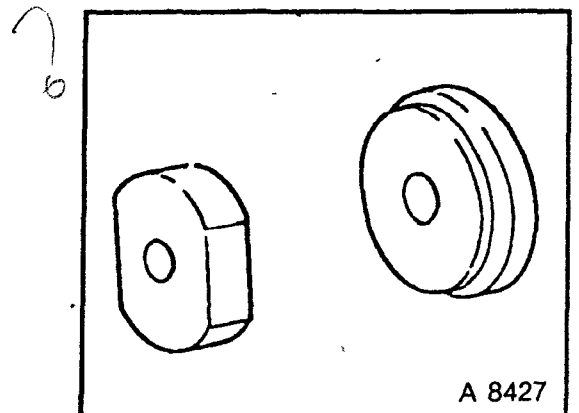
F 10, F 13 manual transmission.  
To screw in and out bearing rings from transmission.

**KM-448 INSTALLER**

F 10, F 13, F 16, F 20 manual transmission.  
To support the end shield and cover of shifting during overhaul operations.  
Alternatively use KM-552.

**KM-451 REMOVER/INSTALLER**

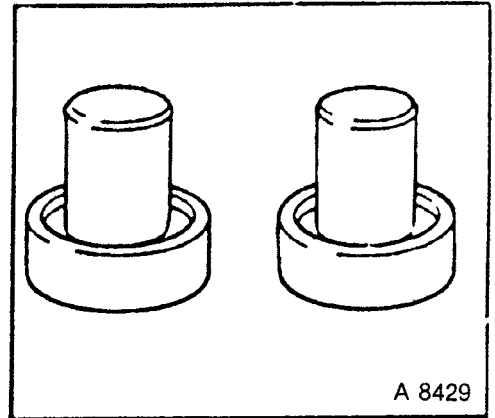
F 10, F 13, F 16, F 20 manual transmission.  
To press in and out tapered roller bearing outer race in transmission in conjunction with KM-303, KM-304, KM-305, KM-502-A.



**KM-453 INSTALLER**

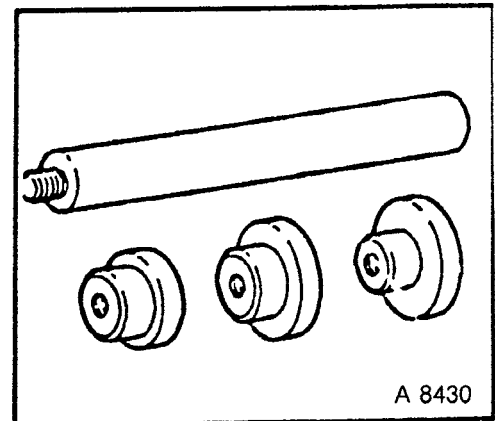
F 10, F 13 manual transmission.

To press in both tapered roller bearings on differential housing.

**KM-454-A REMOVER/INSTALLER**

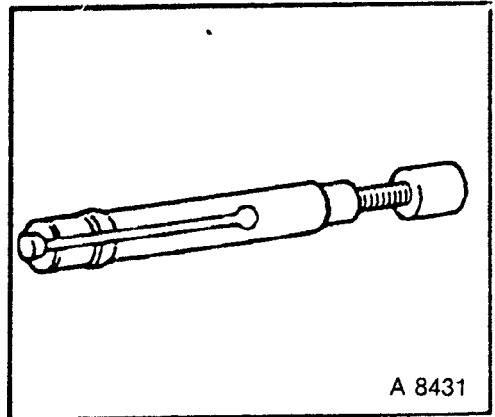
F 10, F 13 manual transmission.

To drive in and out needle sleeves, seal rings from bearing ring and from transmission.

**KM-455 CHECKING DEVICE**

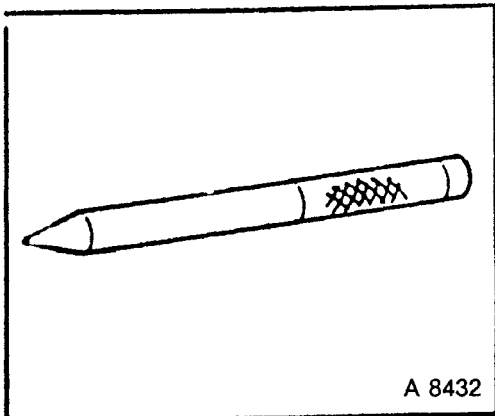
F 10, F 13 manual transmission.

To measure spin torque in conjunction with MKM-536.

**KM-456 CENTERING BOLT**

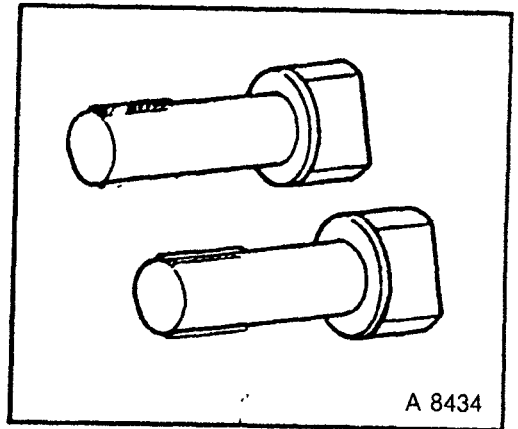
F 10, F 13 manual transmission.

To pre-assemble differential.

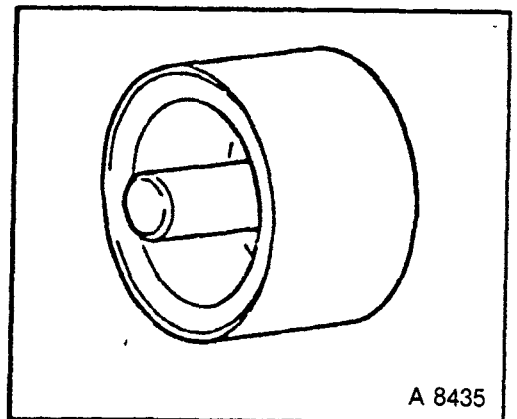


**KM-458-A INSTALLING BOLTS**

F 10, F 13 manual transmission.  
To clamp differential housing in vice.

**KM-459 INSTALLER**

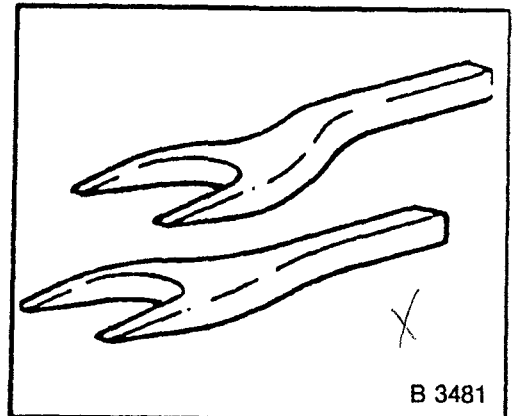
F 10, F 13 manual transmission.  
To press speedometer helical gear onto differential housing.

**KM-460-2-A REMOVER FORKS**

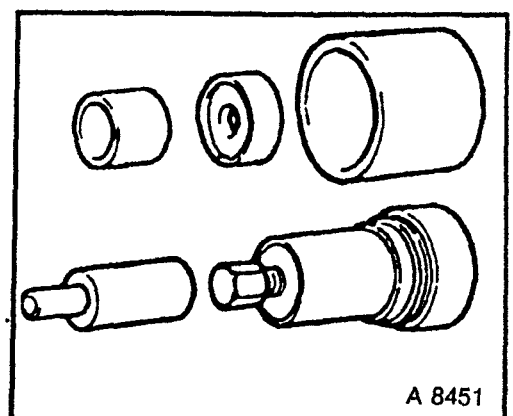
F 10, F 13, F 16, F 20 manual transmission.  
To knock out axle shaft from transmission.

To knock right axle shaft out of  
transmission.

**AUTOMATIC TRANSMISSION AF 20.**

**KM-466-A REMOVER/INSTALLER**

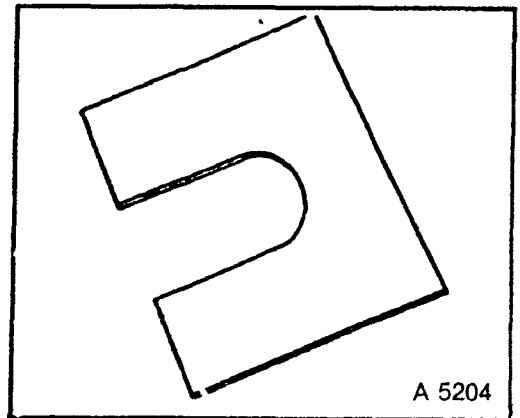
F 16, F 20 manual transmission.  
To press out both seal rings from bearing  
ring and bearing flange.  
F 10, F 13 manual transmission.  
With -3, to press on 5th gear (large) on gear  
cluster.





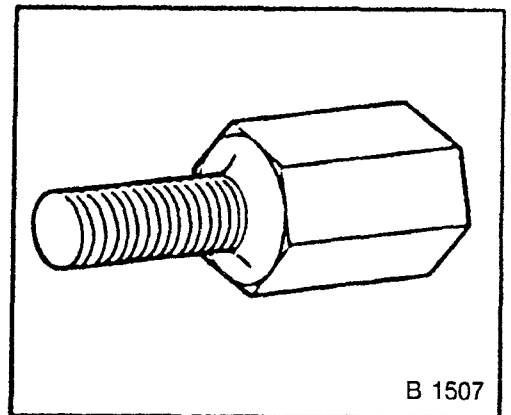
**KM-479-A REMOVER PLATE**

F 10, F 13 manual transmission.  
To press off spacing washer in front of 4th gear from main shaft.  
Replaced by KM-307-B.

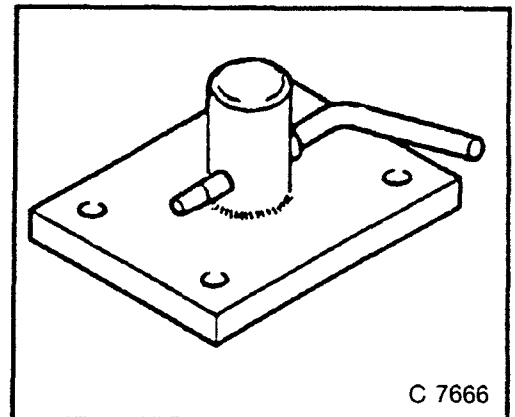
**KM-483 ADAPTER**

F 16, F 20 manual transmission.  
To remove outer sleeve for main shaft bearing from transmission housing in conjunction with KM-313 and KM-J-26941

To knock roller bearing out of auxiliary housing with KM-J-26941 and KM-313.  
**AUTOMATIC TRANSMISSION AF 20**

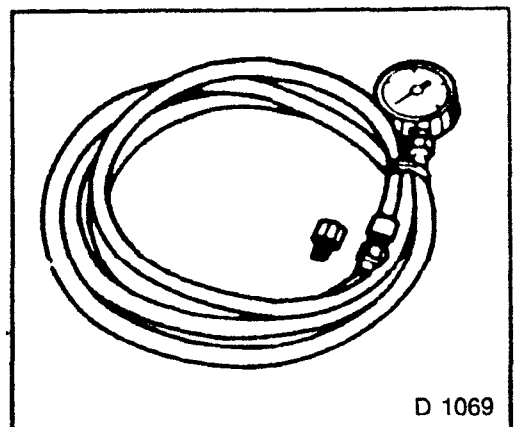
**KM-489 SUPPORT**

F 10, F 13, F 16, F 20 manual transmission.  
Support for transmission bracket

**KM-498-A PRESSURE GAUGE**

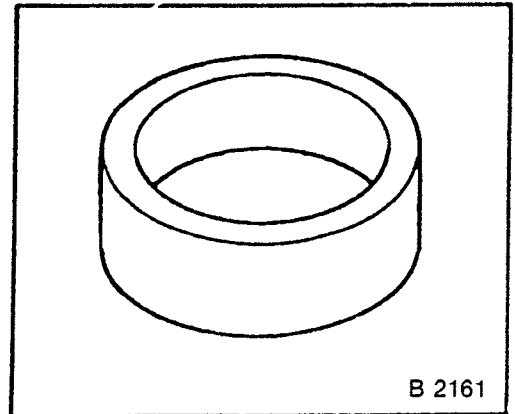
To check the fluid pressure (main and regulating pressure) in conjunction with KM-580, KM-498-B already includes this adapter.

**AUTOMATIC TRANSMISSION AF 20.**



**KM-502-A SPACER RING**

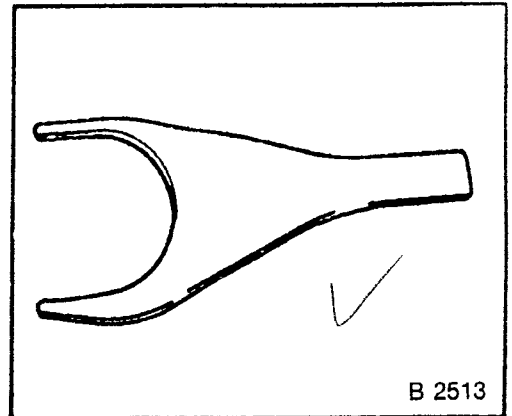
F 10, F 13, F 16, F 20 manual transmission.  
To be placed underneath while knocking out tapered roller bearing outer race in conjunction with KM-304 and KM-451.



B 2161

**KM-503-A REMOVING FORKS**

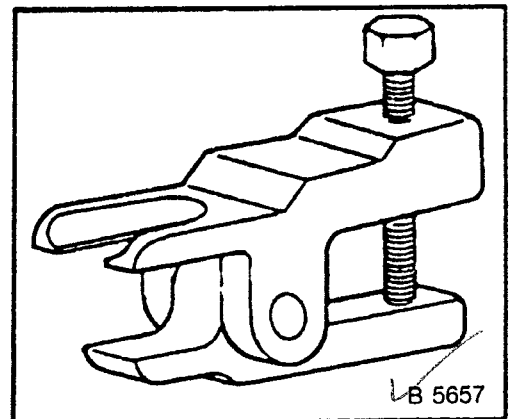
F 16, F 20, F 28 manual transmission.  
To knock out left axle shaft from transmission.

**AUTOMATIC TRANSMISSION AF 20**

B 2513

**KM-507-C BALL JOINT REMOVER**

F 10, F 13, F 16, F 20, F 28 manual transmission.  
To press out guiding joint and tie rod joint.

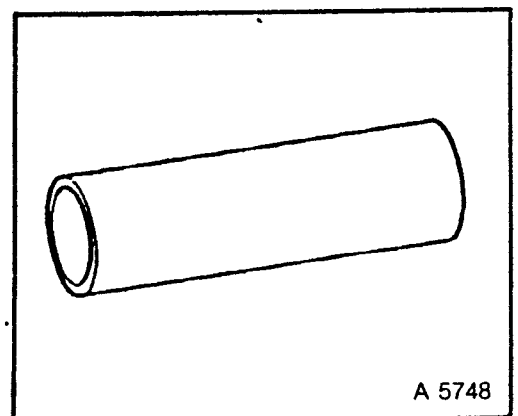


B 5657

**KM-514 INSTALLER**

F 10, F 13, F 16, F 20 manual transmission.  
To press synchromesh body onto main shaft.

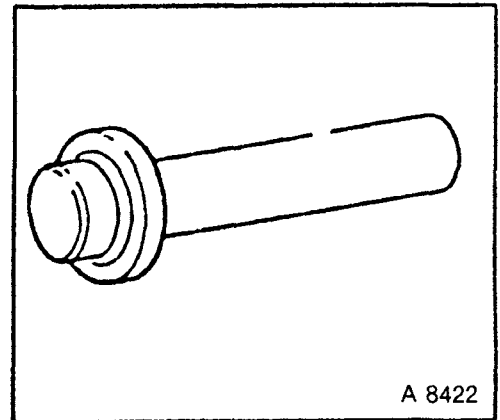
To compress spring plate C1 with KM-697 and KM-698

**AUTOMATIC TRANSMISSION AF 20.**

A 5748

**KM-518 RING INSTALLER**

F 16, F 20, manual transmission  
To press seal ring in transmission.

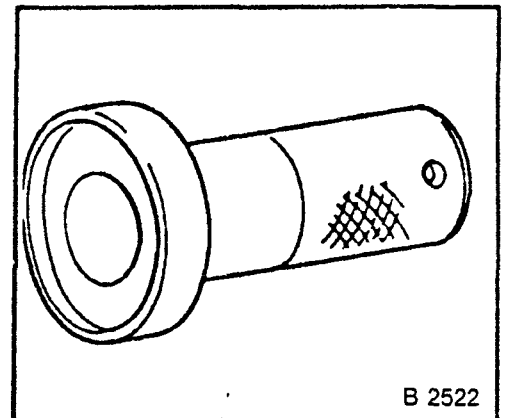


A 8422

**KM-519 RING INSTALLER**

F 16, F 20, F28 manual transmission.  
To drive in both seal rings flush into axle shafts.

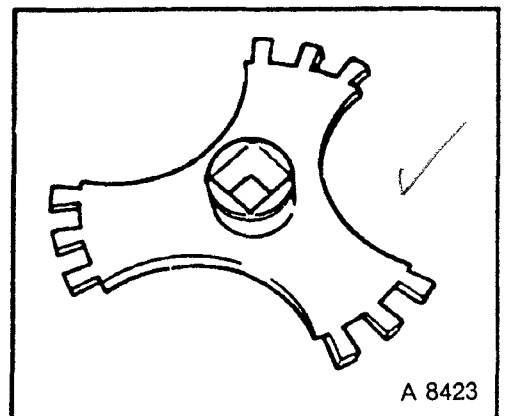
**AUTOMATIC TRANSMISSION AF 20.**



B 2522

**KM-520 REMOVER/INSTALLER**

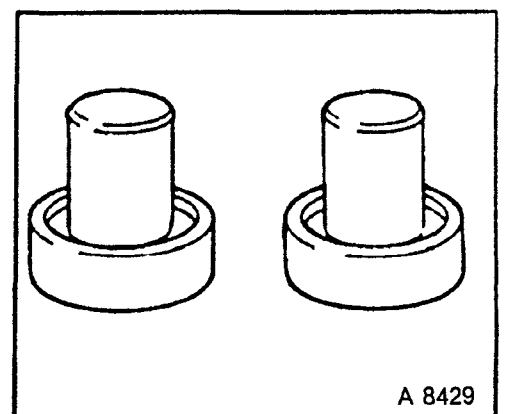
F 16, F 20 manual transmission.  
To screw in and out bearing ring from transmission.



A 8423

**KM-522 INSTALLERS**

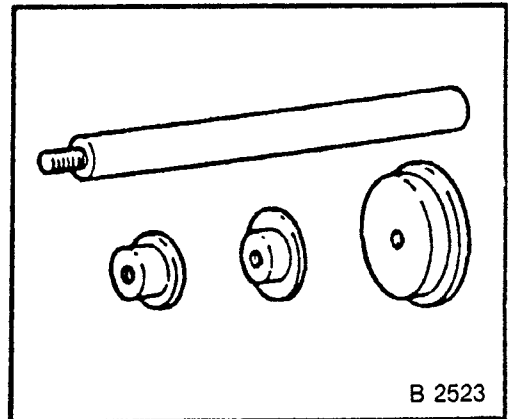
F 16, F 20, manual transmission.  
To press on both tapered roller bearings on differential housing.  
Place underneath while pressing on reverse idler gear axle in end shield.



A 8429

**KM-523 REMOVER/INSTALLER**

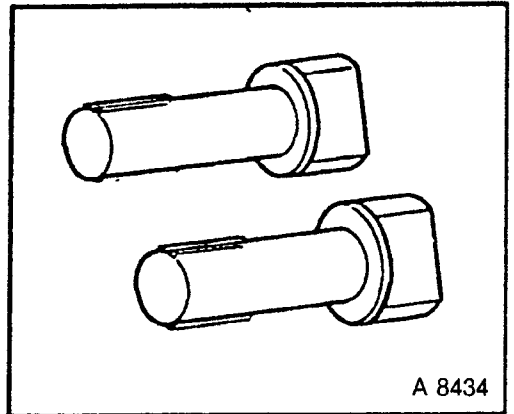
F 16, F 20 manual transmission.  
To drive in and out roller bushing and  
needle sleeve in transmission.



B 2523

**KM-524-A INSTALLING BOLTS**

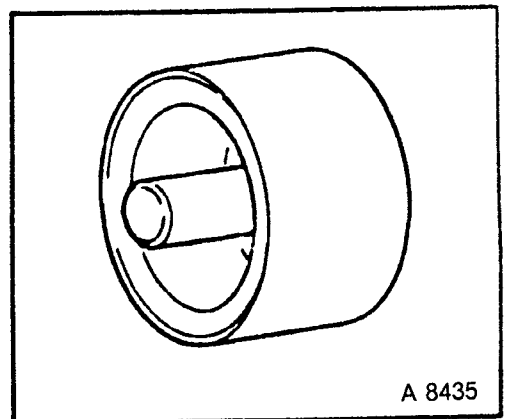
F 16, F 20 manual transmission.  
To clamp differential housing in vice.



A 8434

**KM-525 INSTALLER**

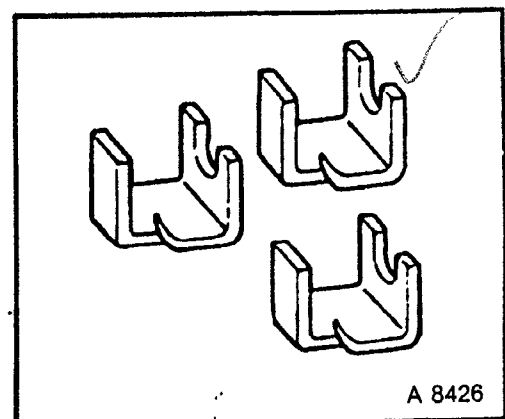
F 16, F 20, manual transmission.  
To press on speedometer helical gear on  
differential housing.



A 8435

**KM-526-A CLAMP SET**

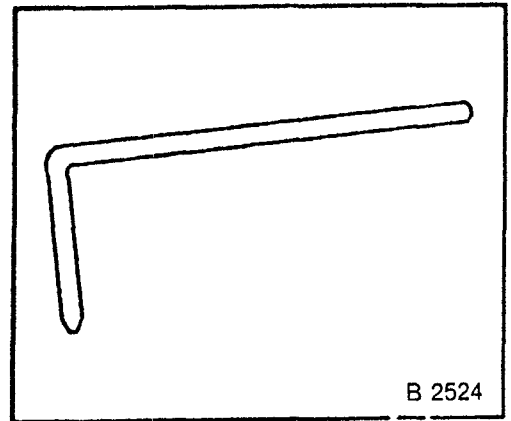
F 10, F 13, F 16, F 20 manual transmission.  
To keep clutch assembly under tension  
with 3 clamps.



A 8426

**KM-527 ADJUSTING TOOL**  
**KM-527-A ADJUSTING TOOL**

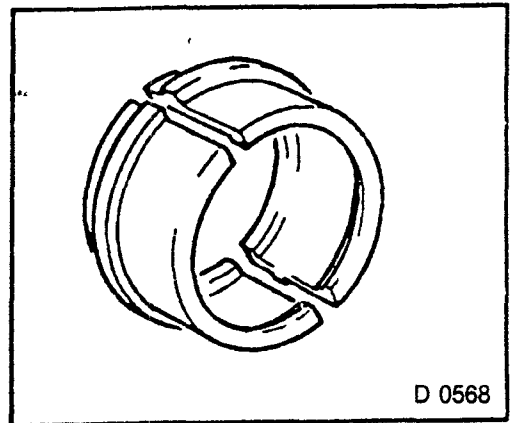
F 10, F 13, F 16, F 20 manual transmission.  
 To adjust transmission shift linkage and to remove and install the transmission cover.  
 Grind off approx. 3 mm at heel of short part of KM-527. KM-527-A has been altered accordingly.  
 With F 28/6 manual transmission, two pieces required.



B 2524

**KM-528 REMOVER RING**

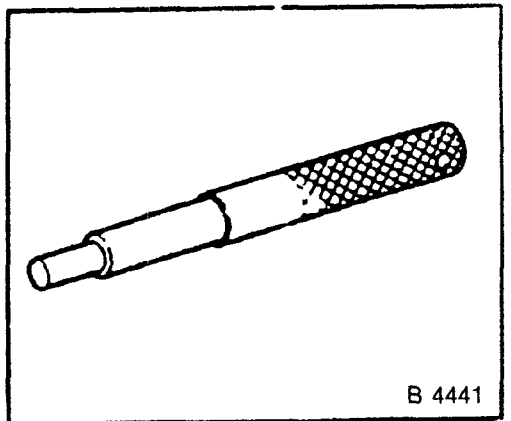
To remove rear tapered roller bearing from planetary gear set P2 with KM-171.  
**AUTOMATIC TRANSMISSION AF 20**



D 0568

**KM-534 GUIDE BOLT**

F 16, F 20 manual transmission.  
 To centre the clutch disc with transmission removed.

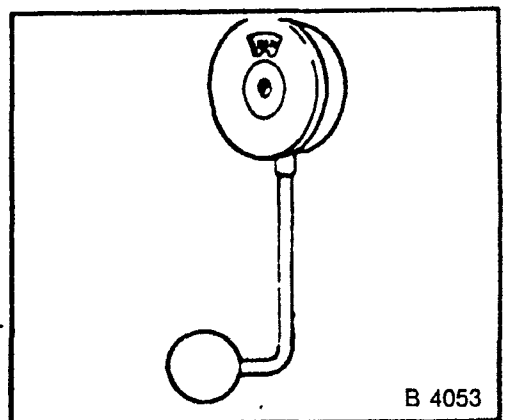


B 4441

**MKM-536 FRICTION COEFFICIENT METER/TORSIOMETER**

F 10, F 13, F 16, F 20 manual transmission.  
 To measure slip torque in conjunction with KM-455 or KM-J-28544.

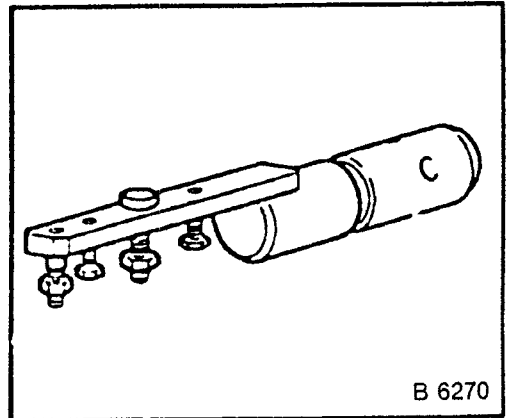
To measure starting and spin torques.  
**AUTOMATIC TRANSMISSION AF 20.**



B 4053

**KM-552     FIXTURE**

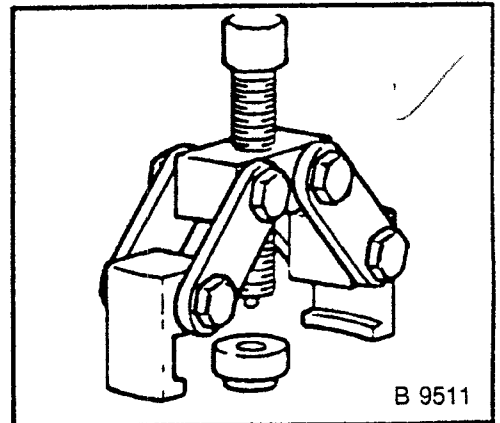
F 10, F 13, F 16, F 20 manual transmission.  
To hold bearing plate and shift cover when overhauling.  
Alternatively use KM-448.



B 6270

**KM-553-A     REMOVER**

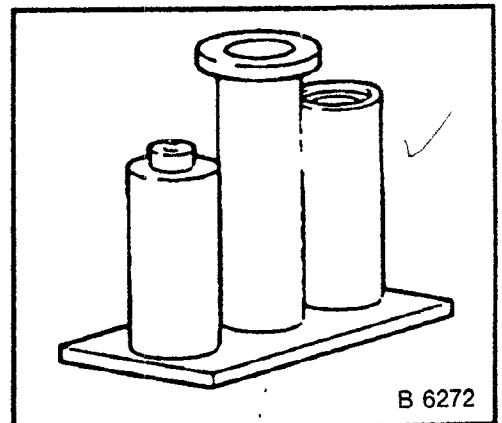
F 10, F 13, F 16, F 20 manual transmission.  
To remove 5th gear.



B 9511

**KM-554     INSTALLER**

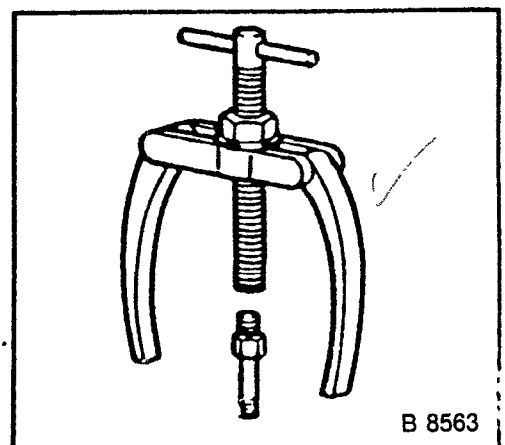
F 10, F 13, F 16, F 20 manual transmission.  
To press on the 5th gear and synchromesh body.



B 6272

**KM-556-A     PULLER SET**

F 10, F 13, F 16, F 20 manual transmission.  
(was KM-449-A in conjunction with Kukko Counter Support 22-1)  
To remove transmission driving shaft from gear cluster.  
To remove roller bushing for mounting of main shaft.  
To remove bearing bushing for mounting of transmission driving shaft.



B 8563

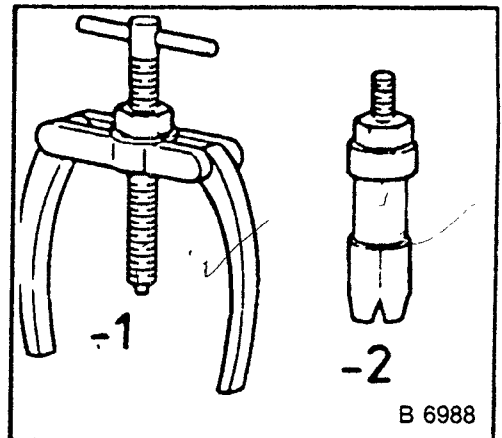
**MKM-557 REMOVER**

F 10, F 13, F 16, F 20, F 28 manual transmission.

To remove both seal rings from bearing ring and from transmission.

To remove both axle shaft seal rings from transmission.

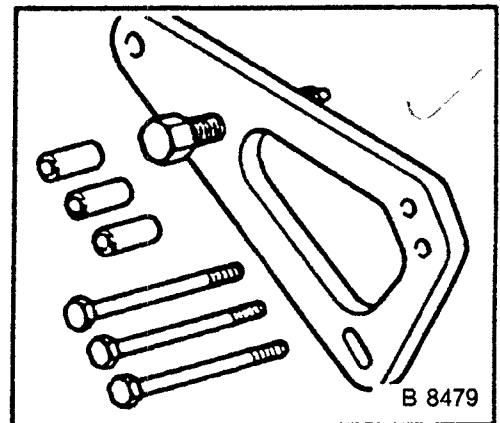
**AUTOMATIC TRANSMISSION AF 20.**

**KM-564 INSTALLER**

F 10, F 13, F 16, F 20 manual transmission.

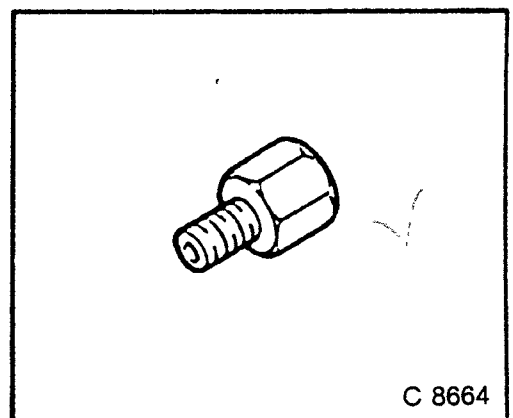
(replacement for KM-449-A and KM-555)

To press in transmission drive shaft.

**KM-580 ADAPTER**

To check fluid pressure, in conjunction with KM-498-A KM-498-B already includes this adapter.

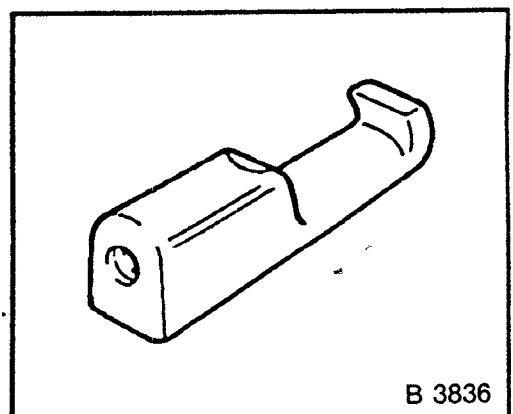
**AUTOMATIC TRANSMISSION AF 20.**

**KM-J-586 REMOVER HOOK**

(in conjunction with KM-J-7004)

To knock out fluid pump seal ring.

**AUTOMATIC TRANSMISSION AF 20.**

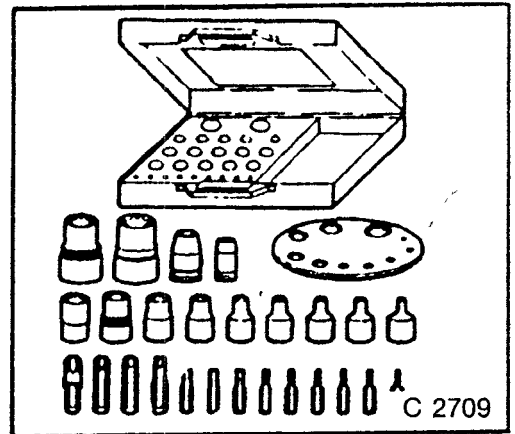


**MKM-604-A TORX BIT AND SOCKET SET**

To remove and install plug for fluid circuit C2.

With MKM-604-22.

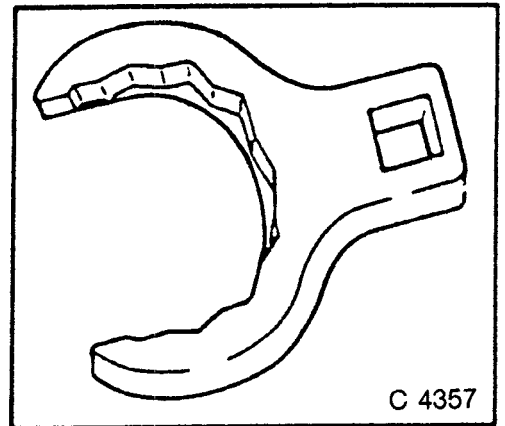
**AUTOMATIC TRANSMISSION AF 20.**



**KM-624 PROPSHAFT WRENCH**

F 16 4x4, F 20 4x4, F 28 manual transmission.

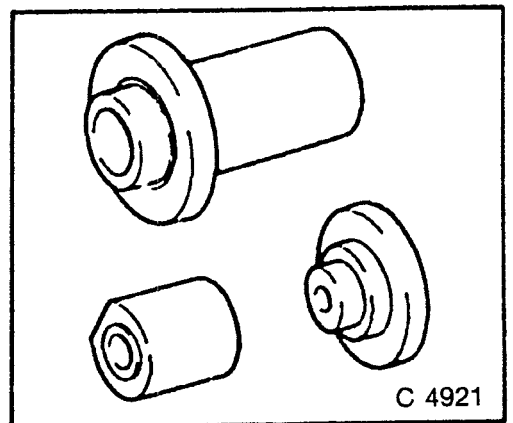
To tighten and loosen slider lock nut on propshaft.



**KM-629 SEAL RING INSTALLER**

To install roller bearing into auxiliary housing.

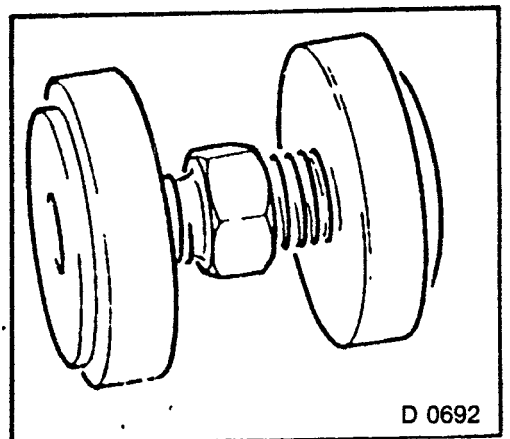
**AUTOMATIC TRANSMISSION AF 20.**



**KM-670 PRE-TENSION TOOL**

F 16, F 20 manual transmission

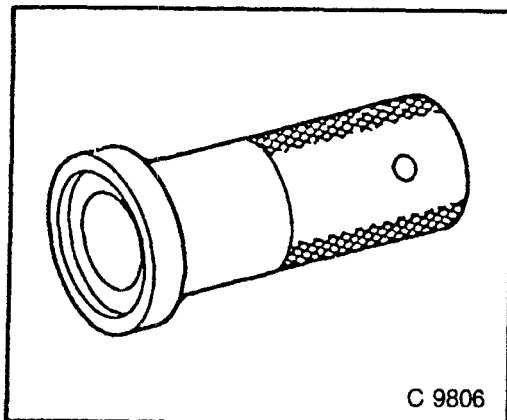
To pre-tension axle shaft bevel gears.



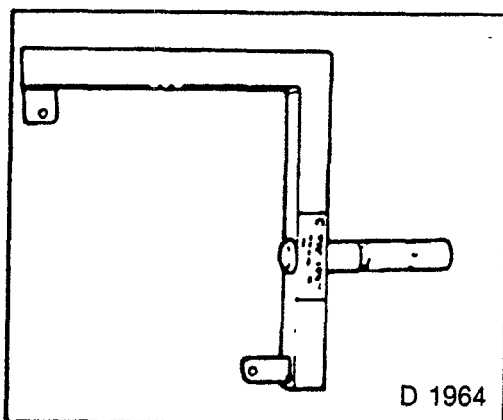


**KM-674 INSTALLER**

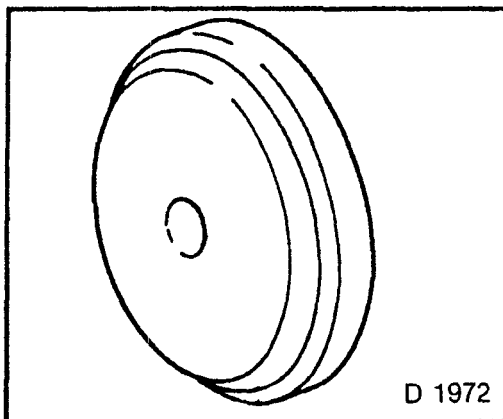
To install fluid pump seal ring and various bearings in transmission  
**AUTOMATIC TRANSMISSION AF 20.**

**KM-694 HOLDING FIXTURE**

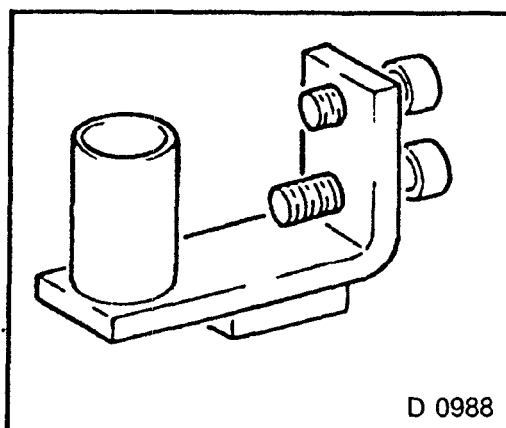
To hold transmission when overhauling with KM-113-2.  
**AUTOMATIC TRANSMISSION AF 20.**

**KM-695 REMOVER/INSTALLER**

To remove and install various bearings in transmission with KM-305. Included in KM-715.  
**AUTOMATIC TRANSMISSION AF 20.**

**KM-696 HOLDER**

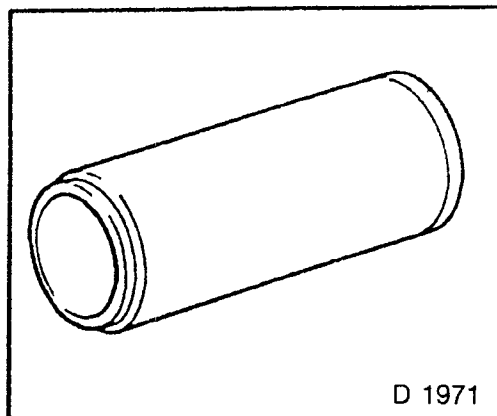
To hold planetary gear set P2 when overhauling.  
Included in KM-715.  
**AUTOMATIC TRANSMISSION AF 20.**



**KM-697 INSTALLER**

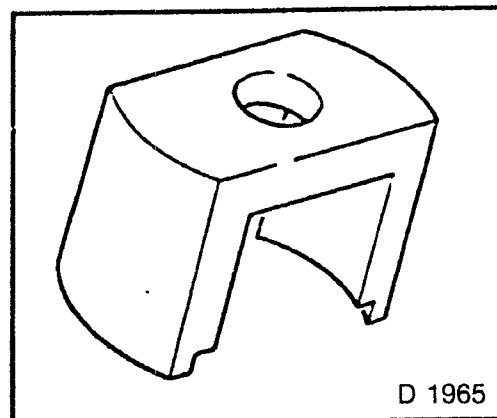
To install various bearings in transmission.  
Included in KM-715.

**AUTOMATIC TRANSMISSION AF 20.**

**KM-698 REMOVER/INSTALLER**

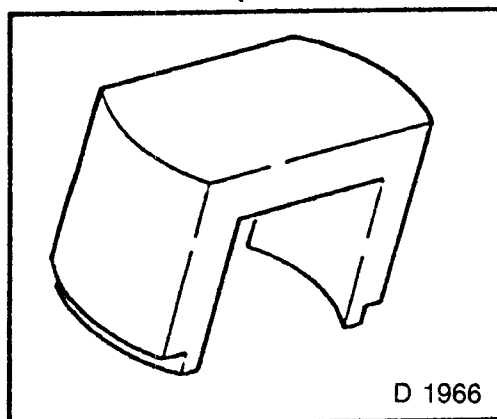
To remove and install return springs from  
various clutches in transmission. Included  
in KM-715.

**AUTOMATIC TRANSMISSION AF 20.**

**KM-699 REMOVER/INSTALLER**

To remove and install spring plate from  
multi-disc brake B1.  
Included in KM-715.

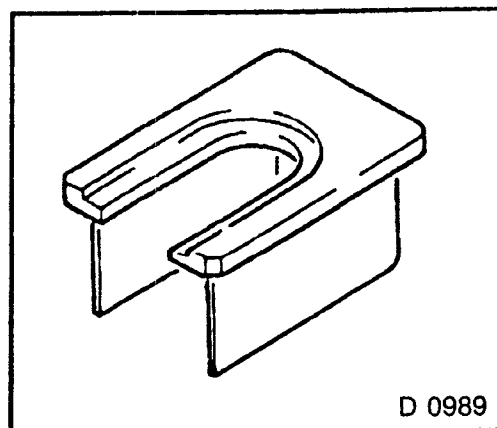
**AUTOMATIC TRANSMISSION AF 20.**

**KM-701 REMOVER SET**

To press off drive gear from planetary gear  
set P2 with KM-407-A.

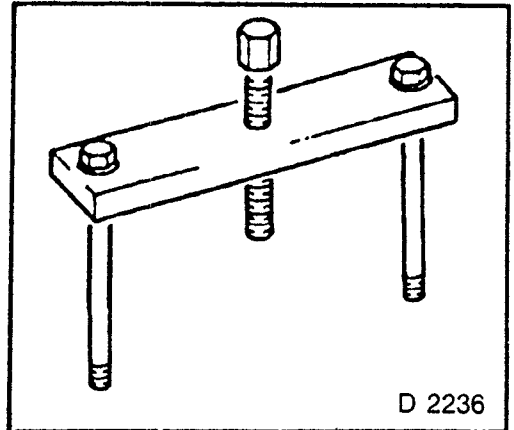
Included in KM-715.

**AUTOMATIC TRANSMISSION AF 20.**

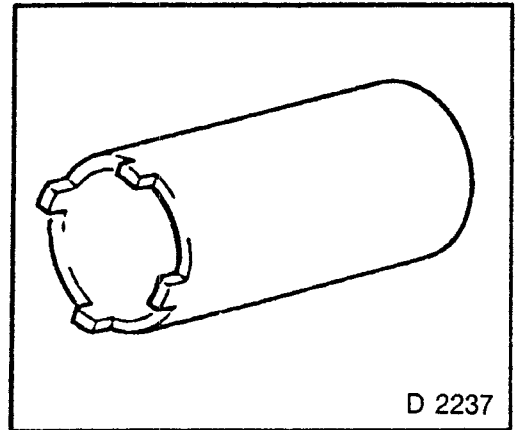


**KM-702 REMOVER**

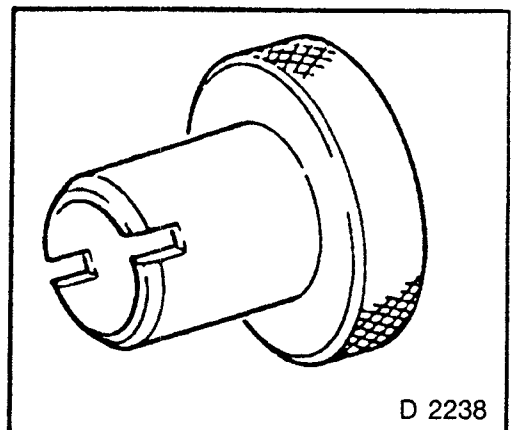
To remove fluid pump. Included in KM-715.  
**AUTOMATIC TRANSMISSION AF 20.**

**KM-703 WRENCH**

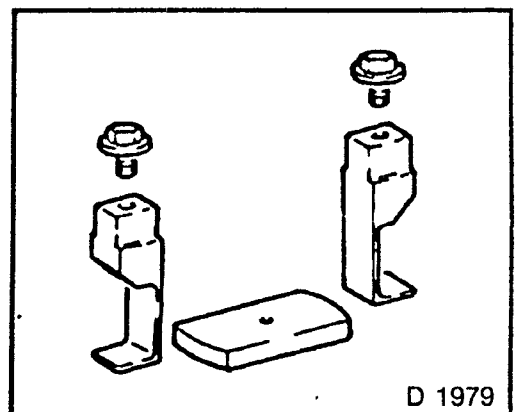
To loosen fastening nut on planetary gear set P2.  
 With new transmissions supplied as hex nut spanner size 36.  
 Included in KM-715.  
**AUTOMATIC TRANSMISSION AF 20.**

**KM-704 CHECKING TOOL**

To check easy turnability of fluid pump.  
 Included in KM-715.  
**AUTOMATIC TRANSMISSION AF 20.**

**KM-709 REMOVER**

To remove both tapered roller bearing outer races from transmission housing using KM-210-A. Included in KM-715.  
**AUTOMATIC TRANSMISSION AF 20.**

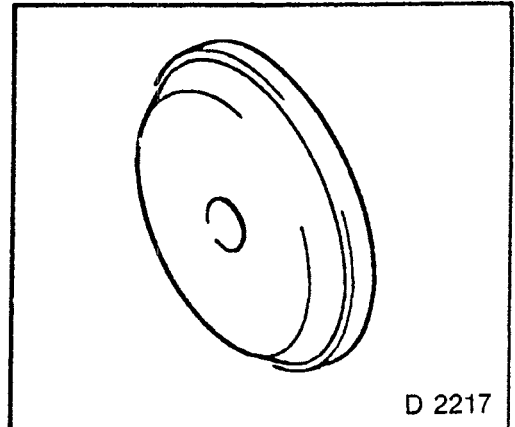


**KM-710 INSTALLER**

To install tapered roller bearing outer race using drift from KM-305.

Included in KM-715.

**AUTOMATIC TRANSMISSION AF 20.**

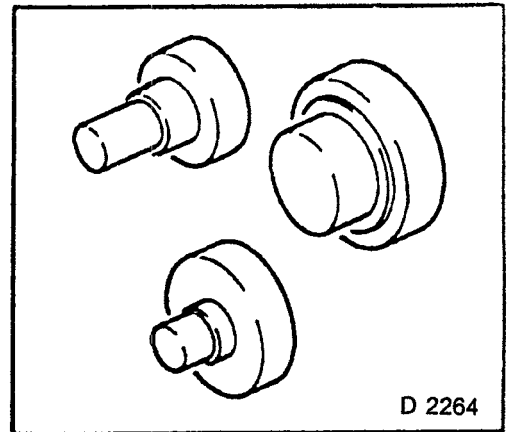


D 2217

**KM-711 INSTALLATION DRIFTS**

To drive in needle bearing in transmission housing. Included in KM-715.

**AUTOMATIC TRANSMISSION AF 20.**

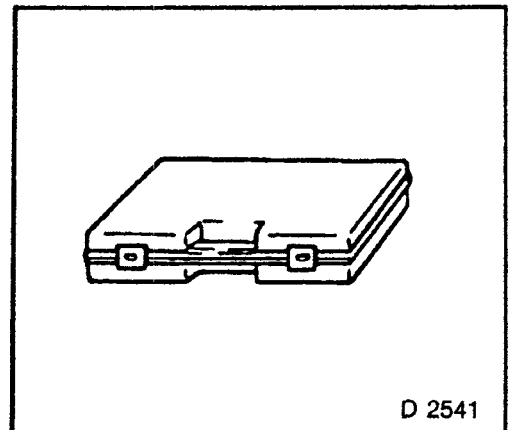


D 2264

**KM-715 TOOL SET**

Consists of 12 tools with tool case:  
KM-695, KM-696, KM-697, KM-698, KM-699,  
KM-701, KM-702, KM-703, KM-704, KM-709,  
KM-710, KM-711.

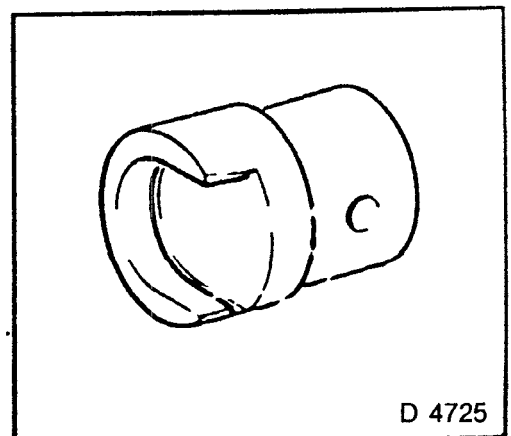
**TO OVERHAUL AUTOMATIC  
TRANSMISSION AF 20.**



D 2541

**KM-727 REMOVER**

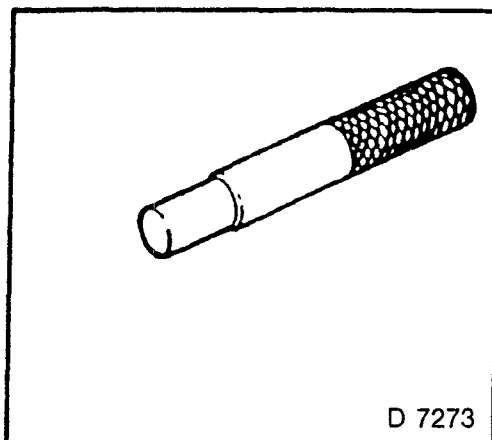
F 10, F 13, F 16, F 20 manual transmission.  
To remove 4 closure plugs for shifting lock  
from end shield in conjunction with  
KM-328-B



D 4725

**KM-736 GUIDE BOLT**

To center clutch plate on vehicles with F 28/6 transmission.

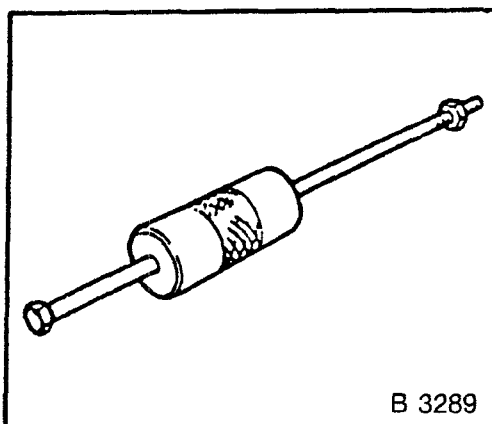


D 7273

**KM-J-7004 SLIDE HAMMER**

F 10, F 13, F 16, F 20 manual transmission.  
To drive in new bearing bushings for clutch release lever in transmission.

To drive fluid pump seal ring out of transmission in conjunction with KM-586  
**AUTOMATIC TRANSMISSION AF 20**

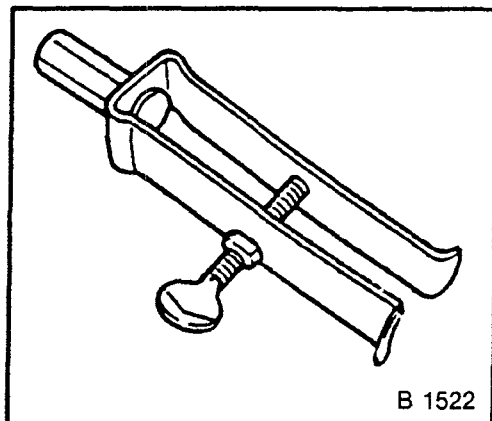


B 3289

**KM-J-26941 REMOVER**

To remove outer sleeve for main shaft bearing from transmission housing in conjunction with KM-313 and KM-483.

To knock roller bearing out of auxiliary housing with KM-313 and KM-483  
**AUTOMATIC TRANSMISSION AF 20.**



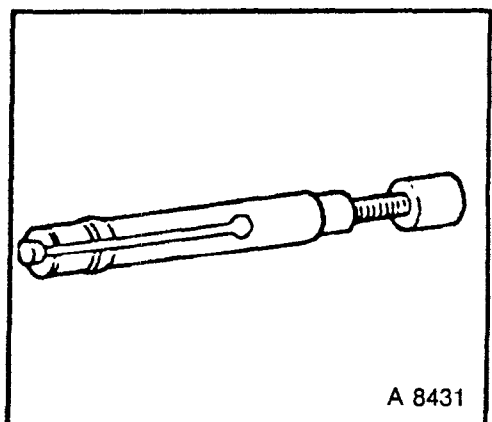
B 1522

**KM-J-28544 CHECKING DEVICE**

F 16, F 20 manual transmission.  
To measure spin torque in conjunction with KM-536.

To measure starting torque with MKM-536.  
**AUTOMATIC TRANSMISSION AF 20.**

To increase the transmitted torque (measurement with transmission gear set), KM-455-A is equipped with a rubber hose. This hose is available separately for retrofitting on the expanding part of KM-J-28544.



A 8431

## TECHNICAL DATA

### Clutch

#### DESIGN: SINGLE PLATE DRY CLUTCH, MANUAL ADJUSTMENT

| Engine  | Diameter of clutch plate<br>(in./mm) | Outer and inner diameter of lining<br>(mm) | Thickness of lining<br>(mm) | Material                         |
|---------|--------------------------------------|--|-----------------------------|----------------------------------|
| 14 NV   | 7.5/190                              | 190/134                                    | 3.5                         | compressed fibre (asbestos-free) |
| C 16 NZ | 8/200                                | 200/134                                    | 3.5                         | compressed fibre (asbestos-free) |
| C 16 SE | 8.5/216                              | 216/144                                    | 3.5                         | compressed fibre (asbestos-free) |
| C 20 XE | 9/228                                | 228/150                                    | 3.5                         | compressed fibre (asbestos-free) |

### Manual Transmission and Differential

| Survey Engines                         | 14 NV  | C 16 NZ | C 16 SE | C 20 XE   |
|--|--------|---------|---------|-----------|
| Manual transmission                    | F 10/5 | F 13/5  | F 13/5  | F 20/5 CR |
| Drive ratio                            | 4.18   | 4.18    | 3.94    | 3.42      |
| (Number of grooves for identification) | (0)    | (0)     | (3)     | (0)       |

#### Identification

| Engine | Transmission | Type | Drive ratio | Converter | Control unit |
|--------|--------------|------|-------------|-----------|--------------|
| 18SE   | AF 20        | LH   | 2,81        | K 250     | YQ           |

#### Fluid Pressure Check

Test conditions: Transmission fluid level correct, transmission at operating temperature.  
 Use Adapter KM-580 or KM-498-4 and Manometer KM-498-1.  
 At full load, do not check for more than 5 seconds, danger of overheating.  
 Tolerances are permissible for the test values given in bar:  
 $\pm 0.5$  bar at idle speed,  $\pm 2.0$  bar with increased engine speed.

#### Test values:

| Engine | Selector lever position | Idle speed    |     |     |     | Full load     |       |       |       |
|--------|-------------------------|---------------|-----|-----|-----|---------------|-------|-------|-------|
|        |                         | Main pressure | C 1 | C 2 | B 4 | Main pressure | C 1   | C 2   | B 4   |
| 18SE   | R<br>D, 3, 2, 1         | 5.0 — 5.8     | 0   | 5.0 | 5.0 | 17.0 — 19.0*  | 0*    | 18.0* | 18.0* |
|        |                         | 2.6 — 3.0     | 2.8 | 0   | 2.8 | 11.4 — 12.6*  | 12.0* | 0*    | 12.0* |

\*At engine speed 2500  $\pm$  150 rpm.

**Shifting Point Table**

Engine: 18SE

Selector lever position:

Operating conditions:

Driving mode:

Shifting point (km/h) in driving gear:

1 — 2

2 — 3

D3 — 4

D4 — 3

3 — 2

2 — 1

|        |  | Overall ratio: 2.81            |       |                                  |       |                    |       |
|--------|--|--------------------------------|-------|----------------------------------|-------|--------------------|-------|
|        |  | D/3                            | D/3   | D/3                              | D/3   | D/3                | D/3   |
|        |  | Minimal throttle valve opening |       | Kickdown touched (full throttle) |       | Kickdown depressed |       |
|        |  | Economy                        | Sport | Economy                          | Sport | Economy            | Sport |
| 1 — 2  |  | 14                             | 30    | 43                               | 59    | 59                 | 59    |
| 2 — 3  |  | 23                             | 40    | 80                               | 105   | 105                | 105   |
| D3 — 4 |  | 43                             | 70    | 135                              | 178   | 162                | 162   |
| D4 — 3 |  | 30                             | 30    | 117                              | 170   | 152                | 152   |
| 3 — 2  |  | 17                             | 17    | 60                               | 95    | 95                 | 95    |
| 2 — 1  |  | 12                             | 12    | 20                               | 49    | 49                 | 49    |

**Driving gear**

Manual downshifting possible at driving speeds under (km/h):

- D — 3 entire speed range
- 3 — 2 105 — for both driving modes
- 2 — 1 59 — for both driving modes

Gear shifts possible at driving speeds under (km/h):

- D — R 7
- N — R 7
- R — P 0 — vehicle stationary, (mechanical blocking mechanism)

Variations from the given shifting points are generally tolerances in the speedometer display: — 2% to + 6%

| MODEL  | DESIG-NATION | TRANSM.  | FINAL DRIVE | FIRST GEAR | SECOND GEAR | THIRD GEAR | FOURTH GEAR | FIFTH GEAR | SIXTH GEAR | CLUTCH DIA. |
|--------|--------------|----------|-------------|------------|-------------|------------|-------------|------------|------------|-------------|
| KADETT | 140          | F10/4 WR | 4,18        | 3,545      | 1,957       | 1,303      | 0,892       | 0,707      | N/A        | 190/134     |
| ASTRA  |              | F10/4 WR | 4,18        | 3,545      | 1,957       | 1,303      | 0,892       | 0,892      | N/A        | 190/134     |
| KADETT | 140 S        | F13/5 CR | 3,94        | 3,545      | 2,143       | 1,429      | 1,121       | 0,892      | N/A        | 190/134     |
| ASTRA  | 160i         | F13/5 WR | 3,94        | 3,545      | 1,957       | 1,303      | 0,892       | 0,707      | N/A        | 200/134     |
| KADETT |              | F13/5 WR | 3,94        | 3,545      | 1,957       | 1,303      | 0,892       | 0,707      | N/A        | 200/134     |
| ASTRA  | 160i E       | F13/5 CR | 3,74        | 3,545      | 2,143       | 1,429      | 1,121       | 0,892      | N/A        | 200/134     |
| ASTRA  | 160i S       | F13/5 CR | 3,74        | 3,545      | 2,143       | 1,429      | 1,121       | 0,892      | N/A        | 200/134     |
| ASTRA  | 180i         | F16/5 WR | 3,94        | 3,545      | 1,952       | 1,276      | 0,892       | 0,707      | N/A        | 216/144     |
| ASTRA  | 180i AT      | AF20/4   | 2,81        | 3,672      | 2,098       | 1,391      | 1,00        | N/A        | N/A        | 241         |
| ASTRA  | 200i         | F16/5 WR | 3,94        | 3,545      | 1,952       | 1,276      | 0,892       | 0,707      | N/A        | 216/144     |
| ASTRA  | 200i E       | F20/5 CR | 3,42        | 3,545      | 2,158       | 1,478      | 1,129       | 0,886      | N/A        | 228/154     |
| KADETT | 200i S       | F16/5 CR | 3,72        | 3,545      | 2,158       | 1,478      | 1,129       | 0,886      | N/A        | 216/144     |
| KADETT | 200t S       | F28/6 CR | 3,72        | 3,57       | 2,16        | 1,45       | 1,10        | 0,89       | 0,74       | 228/150     |

**Transmission fluid:**

Manual — B040075 (Auto-Dexron 11D)

Filling quantity: Manual transmission with differential

- F 10/5 = 1,6 litres
- F 13/5 = 1,6 litres
- F 16/5 = 1,9 litres
- F 20/5 = 1,9 litres

## RECOMMENDED TORQUE VALUES (CLUTCH AND TRANSMISSION)

|   | Nm    |
|---|-------|
| Bearing flange for differential to transmission (F 16 and F 20) .....                 | 25    |
| Bearing support for pawl to end shield .....  | 7**   |
| Bolt for shift rod clamp .....  | 15    |
| Bridge for rocker arm to end shield .....   | 7**   |
| Castellated nut, ball joint to steering knuckle .....                                 | 70    |
| Closure cover for clutch to transmission:   |       |
| Light alloy version .....   | 6     |
| Sheet metal version .....   | 12    |
| Clutch assembly to flywheel .....   | 15    |
| Clutch fork to clutch release lever .....   | 35    |
| Damping element (gearshift lever) to underbody .....                                  | 6     |
| Differential cover to transmission:   |       |
| Light alloy version .....   | 18    |
| Sheet metal version .....   | 30    |
| Drive gear (driven) to differential housing .....                                     | 70*   |
| End shield cover and end shield to transmission, M 8 x 1.25 .....                     | 20    |
| End shield to transmission, M 7 x 1 .....   | 15    |
| Engine suspension bracket, front left, damping block to front frame side member ..... | 65*** |
| Engine suspension bracket, front left, to transmission .....                          | 60    |
| Engine suspension bracket, rear, to front frame side member .....                     | 40    |
| Fillister head bolt to transmission drive shaft .....                                 | 15    |
| Locking plate to adjustment nut for tapered roller bearing (differential) .....       | 9     |
| Reversing lamp switch .....   | 20    |
| Shift cover to transmission .....   | 15    |
| Thrust bearing guide to transmission .....  | 5     |
| Transmission to engine block .....  | 75    |
| Wheel bolts .....   | 110   |

\* Turn a further 30° to 45°.

\*\* Recut threaded bore holes and insert new bolts with Locking Compound (Loctite 242).

\*\*\*Recut threaded bore holes M 10 x 1.25 and insert new bolts with Locking Compound (Loctite 242).

## RECOMMENDED TORQUE VALUES (4-SPEED AUTOMATIC TRANSMISSION AF 20)

|  | Nm  |
|--|-----|
| Accumulator cover for reduction brake to main case .....     | 10  |
| Actuating lever to selector lever shaft .....                | 16  |
| Anchor bolt to main case .....                               | 170 |
| Auxiliary housing cover to transmission .....                | 5   |
| Auxiliary housing to main case .....                         | 30  |
| 3 bolts for fluid baffle plate to auxiliary housing .....    | 6   |
| Bracket, engine suspension front left, to transmission ..... | 60  |
| Bracket, engine suspension rear, to front axle body .....    | 40  |
| Bracket, wiring harness to transmission .....                | 30  |
| Cam plate to main case .....                                 | 10  |
| Centre to rear valve body .....                              | 7   |
| Clamp bolt to selector lever actuation cable .....           | 6   |
| Console to floor panel .....                                 | 10  |
| Converter housing protective plate to transmission .....     | 7   |
| Converter to drive disc .....                                | 50  |



|  | Nm  |
|--|-----|
| Cover C1 to rear cover . . . . .   | 10  |
| Covers no. 1 and no. 2 to rear valve body . . . . .                            | 7   |
| Damping block to front frame side member . . . . .                             | 65  |
| Detent spring to main case . . . . .   | 10  |
| Drain plug to main case . . . . .  | 35  |
| Drive gear (driven) to differential . . . . .                                  | 100 |
| Fluid baffle plate to main case . . . . .                                      | 7   |
| Fluid drain screw to transmission . . . . .                                    | 45  |
| Fluid lines to transmission/fluid cooler . . . . .                             | 22  |
| Fluid pressure regulator clamp to front valve body . . . . .                   | 7   |
| Fluid pump to transmission . . . . .   | 25  |
| Fluid screen to main case . . . . .  | 7   |
| Fluid temperature sensor cover plate to transmission . . . . .                 | 25  |
| Fluid temperature sensor to transmission . . . . .                             | 25  |
| Front to centre valve body . . . . .   | 7   |
| Hose clamps to fluid lines . . . . .   | 1.2 |
| Intake cover to transmission . . . . .   | 7   |
| Main case plate to main case . . . . .   | 7   |
| Pipe clamp to fluid line . . . . .   | 6   |
| 7 plugs — fluid pressure M 8: . . . . .  | 8   |
| 1 plug — fluid pressure M 14: . . . . .  | 35  |
| 1 plug — fluid pressure M 18 (Torx): . . . . .                                 | 35  |
| 2 plugs — fluid pressure M 20: . . . . .                                       | 35  |
| Rear cover to transmission M 8: . . . . .                                      | 25  |
| M 6: . . . . .   | 10  |
| Retaining plate for solenoid valves wiring harness to transmission . . . . .   | 13  |
| Selector lever actuating cable to console/transmission bracket . . . . .       | 6   |
| Selector lever position switch to selector lever shaft . . . . .               | 8   |
| Selector lever position switch/fluid filler tube to transmission . . . . .     | 25  |
| Selector lever to console . . . . .  | 28  |
| Side cover to transmission . . . . .   | 25  |
| 3 solenoid valves to front valve body . . . . .                                | 7   |
| Stator shaft to fluid pump (Torx 30) . . . . .                                 | 12  |
| Transmission input speed sensor . . . . .                                      | 6   |
| Transmission output speed sensor . . . . .                                     | 6   |
| Transmission to engine . . . . .   | 75  |
| Valve body to transmission . . . . .   | 7   |
| Use new micro-encapsulated bolts for: Damping block to front frame side member |     |
| Converter to drive disc  |     |
| Recut threads M 10 x 1.25  |     |
| New hose clamps for: Connection hose, fluid lines to transmission              |     |

## Automatic Transmission AF 20

### General Data

|                               |   |
|-------------------------------|---|
| Manufacturer of transmission: | Aisin AW CO., LTD   |
| Number of gears:              | 4 forward gears and 1 reverse gear  |
| Shifting:                     | Automatic and dependent on the position of throttle valve and driving speed   |
| Kickdown:                     | Operates by electric contact to control unit — switch mounted under accelerator   |
| Towing vehicle:               | Never tow vehicle backwards.<br>If transmission is operational:<br>can be towed up to 100 km (62 miles) with a maximum permissible speed of 80 km/h (50 mph)<br><br>If distance is more than 100 km (62 miles) or maximum speed is over 80 km/h (50 mph) or if transmission is defective: raise vehicle at front. |

|                |   |
|----------------|---|
| Fluid quality: | Special Fluid Catalogue No. 19 40 690 (90 013 457) (1 litre) and 19 40 691 (90 020 172) (1/2 litre) or 19 40 699 (90 350 341) and 19 40 700 (90 350 342). |
|----------------|---|

|                   |  |
|-------------------|--|
| Filling quantity: | — after draining fluid: 3.0 to 3.5 litres: |
|-------------------|--|

|                          |  |   |
|--------------------------|--|---|
| Fluid measurement level: | with engine running and selector lever position "P"; | allow to run in idle speed for 1 to 2 minutes;                          |
|                          | — transmission cold:                                 | fluid level on scale side + 20°C must reach the "MAX" mark;             |
|                          | — transmission at operating temp.:                   | fluid level on scale side + 80°C must be between marks "MIN" and "MAX". |

|               |   |
|---------------|---|
| Fluid change: | Drain and refill every 45 000 km or every 36 months. Filter elements are not replaced |
|---------------|---|

|                   |  |
|-------------------|--|
| Trouble-shooting: | The transmission is equipped with a self-diagnosis system.<br>If the fault does not affect operational safety, a trouble code is stored in the control unit; the telltale does not illuminate.<br>The transmission remains functionable, except for the function of the affected component.<br><br>If the telltale illuminates, the control unit switches automatically to the emergency programme.<br>All stored trouble codes can be read out using TECH 1 — see Checking Procedures "Opel Electronic 4-speed Automatic Transmission AF 14/20" |
|-------------------|--|

**Driving Modes**

Economy (4 gear sequence, economical driving)

Switching on: Automatic after switching on ignition  
When switching off "Sport" programme — button "S"

Switching off: Actuation of "Kickdown"  
When switching on "Sport" programme — button "S"

Sport (4 gear sequence, sporty driving)

Switching on and off operates in the opposite way to the "Economy" programme.  
"Sport" programme is automatically switched off when engine is switched off.

Winter (for driving on icy roads in 3rd gear)

Switching on: Selector lever position "D" and driving programme  
"Economy" — button "E"

Automatic when selector lever position in "D", driving speed is less than 60 km/h (37 mph) and convertor output temperature is less than 140°C (284°F).

Switching off: Actuation of button "E" again

Automatic when: Any selector lever position except "D" is used  
Driving speed is more than approx. 80 km/h (50 mph)  
Convertor output temperature is more than 150°C (302°F)  
Driving programme "Sport" is switched on  
"Kickdown" is actuated  
Engine is switched off.

**Transmission Maintenance: Rubber O-rings, Dimensions and Use**

| Component  | Installation position     | Outer/Inner seal ring           | Inner Ø (mm)                   | Cord Ø (mm)                 |
|--|---------------------------|---------------------------------|--------------------------------|-----------------------------|
| Piston for multi-disc brake B <sub>1</sub>       | Fluid pump                | Outer:<br>Inner:                | 98.25<br>50.9                  | 2.62<br>3.1                 |
| Piston for multi-disc brake B <sub>2</sub>       | Fluid pump                | Outer:<br>Inner:                | 147.0<br>123.75                | 2.62<br>2.62                |
| Piston for multi-plate clutch C <sub>1</sub>     | Drive shaft               | Outer:<br>Inner:                | 126.7<br>47.6                  | 3.1<br>2.62                 |
| Piston for multi-plate clutch C <sub>2</sub>     | Drive shaft               | Outer:<br>Inner:                | 98.25<br>47.6                  | 3.1<br>2.62                 |
| Piston for multi-disc brake B <sub>3</sub>       | Main housing              | Outer:<br>Inner:                | 147.0<br>103.2                 | 2.62<br>2.62                |
| Piston for multi-plate clutch C <sub>3</sub>     | Main housing              | Outer:<br>Inner:                | 98.25<br>50.9                  | 3.1<br>2.62                 |
| Cover and piston for reduction brake             | Main housing              | —                               | 41.8                           | 2.4                         |
| Anchor bolt for brake band                       | Main housing              | —                               | 17.8                           | 2.4                         |
| Cover and piston for reduction brake accumulator | Main housing              | —                               | 21.95                          | 2.62                        |
| Cover and piston C <sub>1</sub>                  | Rear cover                | —                               | 26.55                          | 2.62                        |
| Fluid pressure plugs                             | Main or auxiliary Housing | M 8:<br>M 14:<br>M 18:<br>M 20: | 6.07<br>11.68<br>15.41<br>17.8 | 1.78<br>1.98<br>2.21<br>2.4 |
| Wiring harness for solenoid valves               | Main housing              | —                               | 17.8                           | 2.4                         |
| Fluid temperature sensor                         | Main housing              | —                               | 11.68                          | 1.98                        |
| Fluid pump plate                                 | Fluid pump                | —                               | 205.0                          | 3.5                         |

**Transmission Maintenance: List of parts, clutches and brakes**

| Component                         | Installation position | Flange | Steel plate | Lining plate |
|-----------------------------------|-----------------------|--------|-------------|--------------|
| Multi-disc brake B <sub>1</sub>   | Fluid pump            | 1      | 2           | 2            |
| Multi-disc brake B <sub>2</sub>   | Fluid pump            | 1      | 3           | 3            |
| Multi-disc brake B <sub>3</sub>   | Main housing          | 1      | 5           | 5            |
| Multi-plate clutch C <sub>1</sub> | Drive shaft           | 1      | 4           | 4            |
| Multi-plate clutch C <sub>2</sub> | Drive shaft           | 1      | 4           | 4            |
| Multi-plate clutch C <sub>3</sub> | Reduction clutch      | 1      | 4           | 4            |

# **Opel Astra** **Opel Kadett**

## **Workshop Manual**

### **Section L**

## **Fuel System**

Issued by: Service Division  
Delta Motor Corporation  
July, 1993

# Index

*Page*

|  |      |
|--|------|
| ELECTRIC FUEL PUMP, REPLACE .....                              | L- 5 |
| FUEL FILLER PIPE WITH ANTI-LEAK SEAL, REMOVE AND INSTALL ..... | L- 7 |
| FUEL FINE FILTER, REPLACE (INJECTION ENGINES) .....            | L- 8 |
| FUEL TANK SENDER UNIT, REPLACE.....                            | L- 9 |
| FUEL TANK, REMOVE AND INSTALL . . . . .                        | L-10 |
| FUNCTION CHECK OF "ANTI-LEAK-MECHANISM" VALVE .. . . .         | L- 6 |
| INSTRUCTIONS FOR WORKING ON FUEL TANK.....                     | L- 2 |
| WARNINGS AND CONDITIONS . . . . .                              | L- 2 |
| <b>SPECIAL SERVICE TOOLS</b> .....                             | L-14 |
| TECHNICAL DATA ....  | L-15 |
| RECOMMENDED TORQUE VALUES. . . . .                             | L-16 |

# FUEL SYSTEM

## Warnings and Cautions

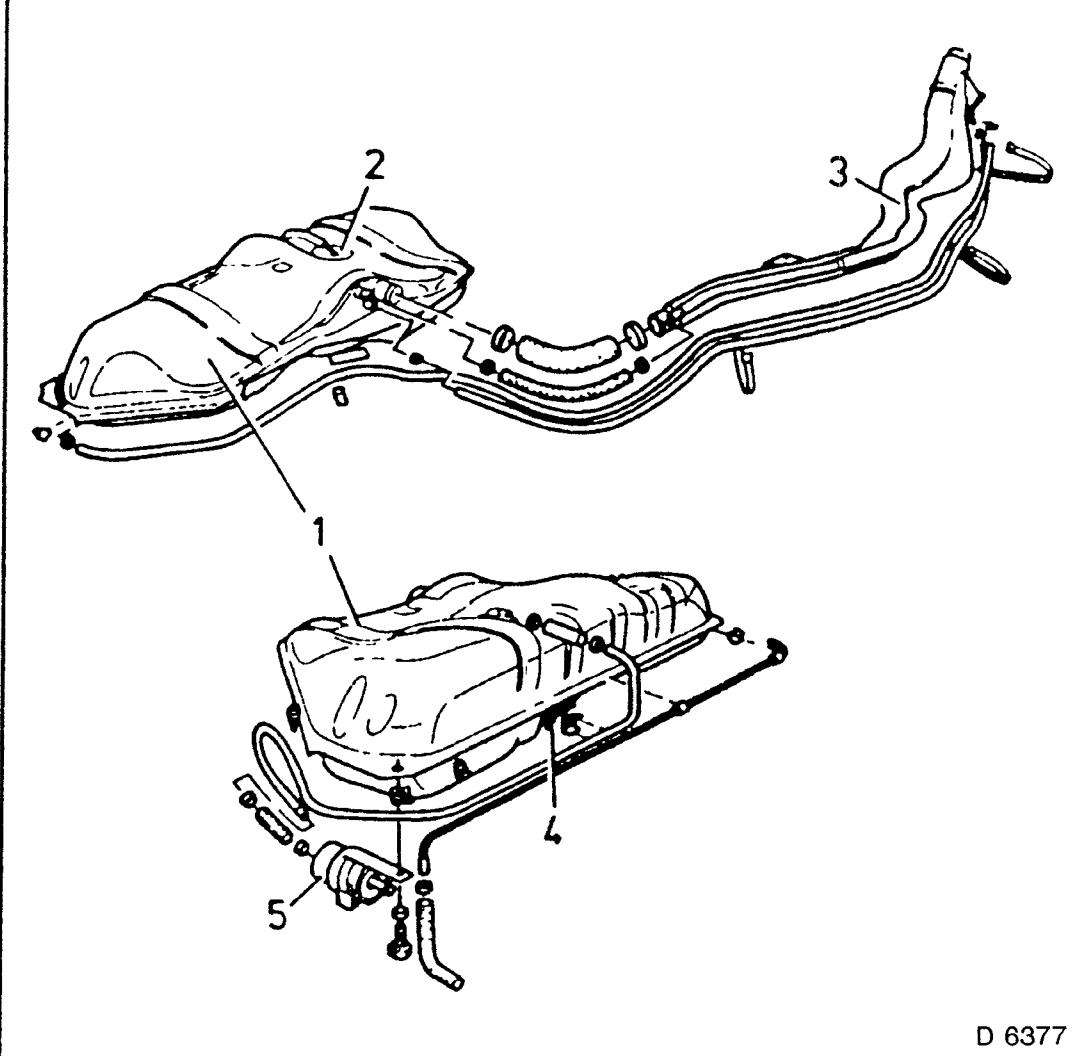
1. Observe the relevant environmental, health and work safety regulations regarding explosive and flammable materials.
2. Whenever working on the fuel system, observe extreme cleanliness
3. Check all parts for signs of wear and replace if necessary.
4. Check fuel lines for routing, abrasion and tight connection.
5. Fuel hoses must not be twisted or constricted when installed.
6. Fuel lines must not touch moving parts or sharp edges.
7. Cables may not be fastened to the fuel lines.
8. Check fuel system for leaks.

## Instructions for Working on Fuel Tank

1. Display appropriate signs, warn of the danger.
2. Avoid any fire or exposed light source.
3. Only work on lifting platforms in sufficiently ventilated areas.
4. Never empty fuel tanks over an installation pit, as fuel vapours will sink into the pit and remain there
5. Empty fuel tank with suitable pump.
6. Store drained fuel in a suitable, closable container.
7. Remove spilt fuel immediately.

# FUEL TANK

- 1 Fuel tank
- 2 Fuel pump
- 3 Fuel filler pipe
- 4 Fuel tank sender unit
- 5 Fuel filter



D 6377

Fig 1



## Electric Fuel Pump — Replace

### WARNING:

Check when filling tank — if necessary drain fuel.

See operation "Fuel Tank, Remove and Install" Page No. 10.

Observe safety regulations.

### REMOVE, DISCONNECT

1. Fold rear seat.
2. Pull back carpet at cut.
3. Plastic covering from floor panel — installation opening.
4. Wiring harness plug.
5. Fuel line from connection.
6. Fastening screws.
7. Fuel pump assembly.

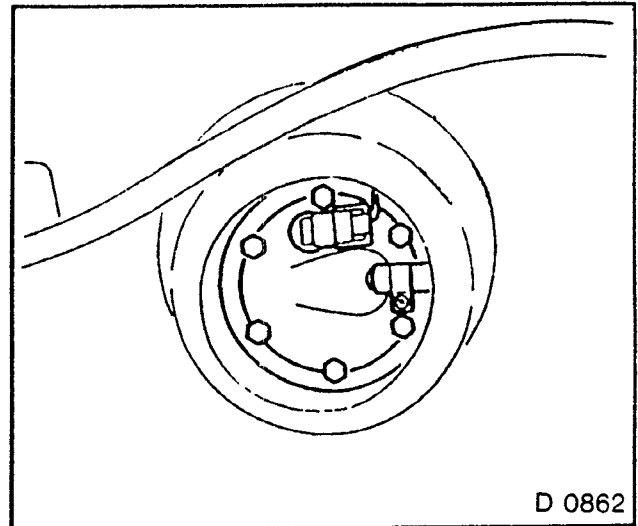


Fig. 3

### DISASSEMBLE

1. Fuel pump assembly.
2. Fuel screen.
3. Hose clip.
4. Fuel hose.
5. Solder off cable (mark).
6. Fuel pump from rubber sleeve.

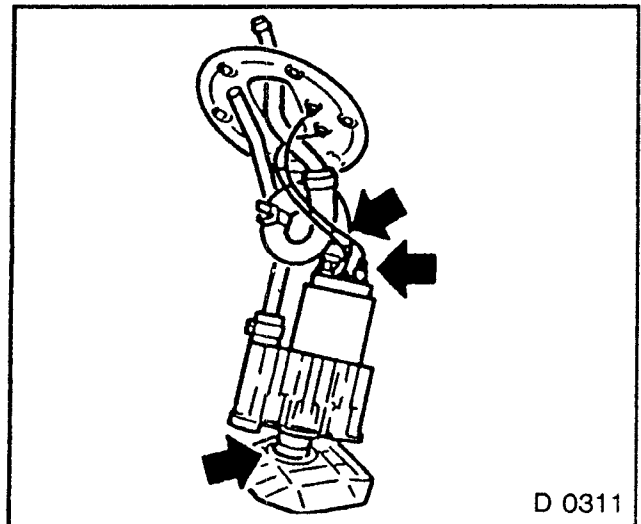


Fig. 4

## ASSEMBLE

- 1 Fuel pump.
- 2 Rubber sleeve.
- 3 Fuel hose.
- 4 Fuel screen
5. Solder cable

### NOTE:

1. **USE NEW GASKET AND SHIMS.**
2. **INSERT BOLTS WITH SEALING COMPOUND.**

## INSTALL, CONNECT

1. Fuel pump in fuel tank.
2. Wiring harness plug.
3. Fuel hose.
4. Plastic covering — installation opening.
5. Carpet.
6. Rear seat bank.

## Function Check of “Anti-leak-Mechanism” Valve

### REMOVE, DISCONNECT

1. Fuel filler pipe with escape safety device.

### INSPECT

- 1 Tilt fuel filler pipe and fill connection A with fuel.

In this position, no fuel should flow from connection B.

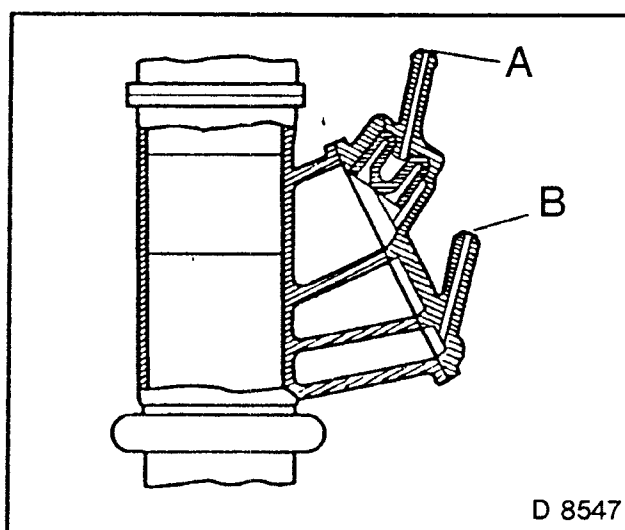


Fig. 5

## Fuel Filler Pipe with Anti-leak Seal — Remove and Install

1. Drain fuel tank — see “Fuel Tank, Remove and Install” page 10.

Observe safety regulations.

### REMOVE, DISCONNECT

- 1 Tank lid.
- 2 Fuel filler pipe fastening screws.

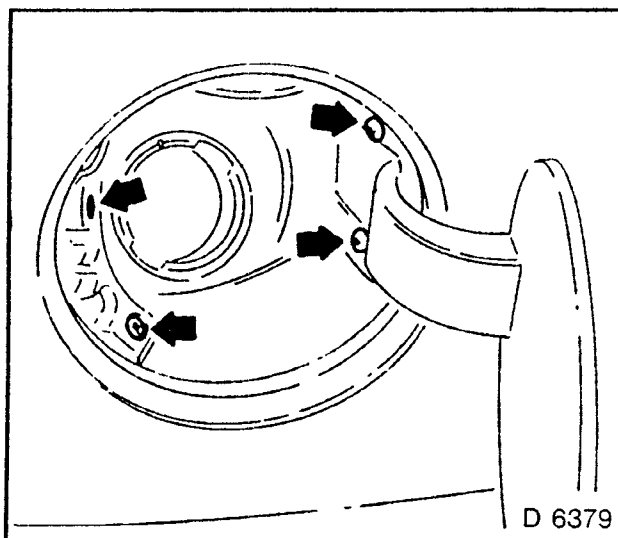


Fig. 6

3. Fastening screw.
- 4 Vent hose.

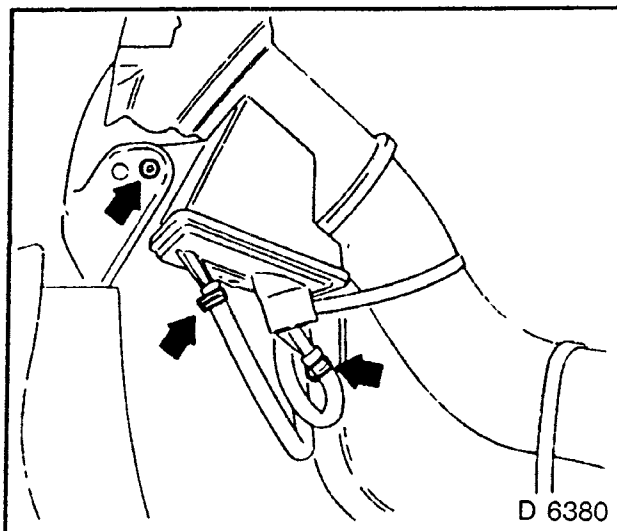


Fig. 7

### REMOVE, DISCONNECT

- 1 Fuel filler pipe
- 2 Hoses
- 3 Fastening screw (on underbody).

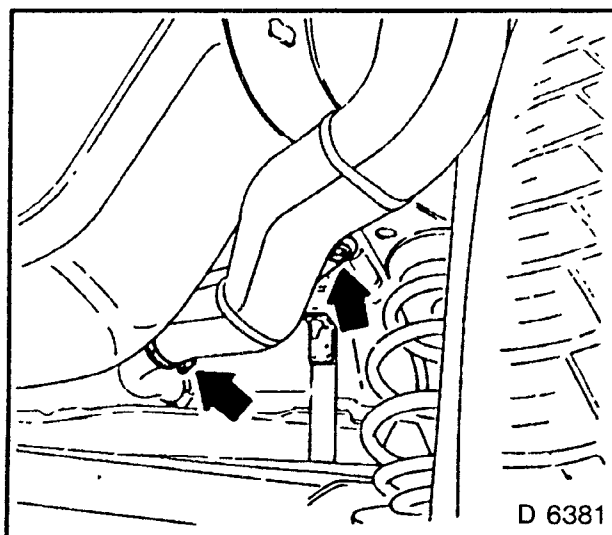


Fig. 8

**INSTALL, CONNECT**

- 1 Fuel filler pipe.
- 2 Hoses.
- 3 Clips
4. Fastening screws.
- 5 Tank lid.

**NOTE:**

**CONNECTION 1 — LINE TO TANK**

**CONNECTION 2 — LINE TO OUTSIDE AIR  
OR ACTIVE CARBON CANISTER**

**USE NEW HOSE CLIPS.**

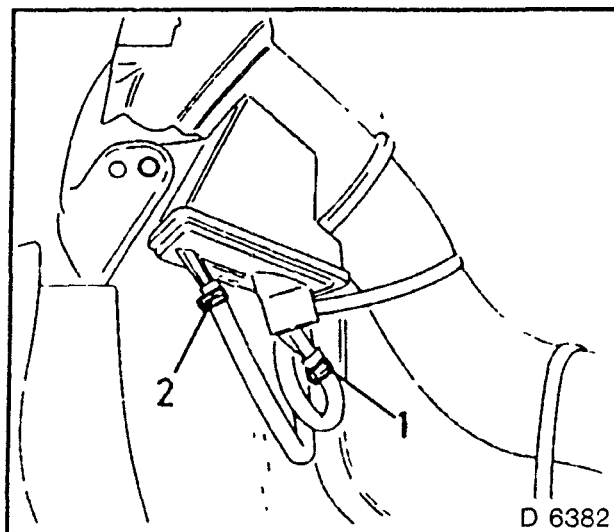


Fig. 9

**Fuel Fine Filter, (Injection Engines) — Replace****REMOVE, DISCONNECT**

1. Fuel fine filter.
- 2 Close fuel hoses with clips.
3. Fuel hoses from fuel fine filter
4. Fastening screw from retaining strap, fuel fine filter.

**WARNING:**

**REMAINING FUEL ESCAPES — OBSERVE  
SAFETY REGULATIONS.**

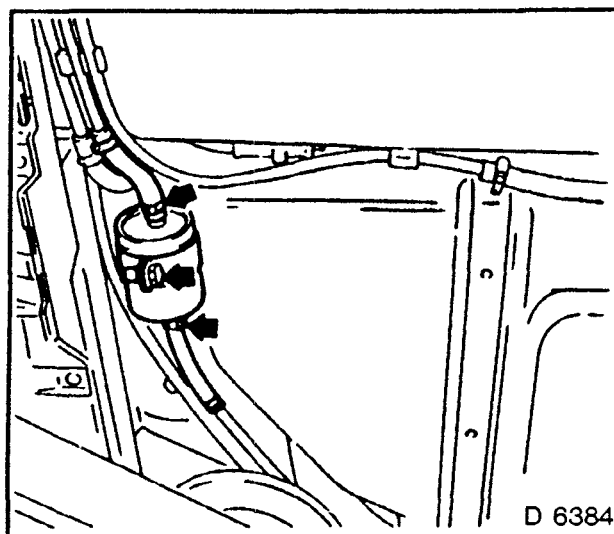


Fig. 10

**INSTALL, CONNECT**

- 1 Fuel fine filter in retainer strap.
- 2 Fuel hoses — use new hose clips.
3. Remove spring clips.

**NOTE:**

**OBSERVE DIRECTION OF FLOW OF  
FILTER (ARROW ON FILTER HOUSING).**

## Fuel Tank Sender Unit — Replace

Drain fuel tank — see operation “Fuel Tank, Remove and Install” page 10.

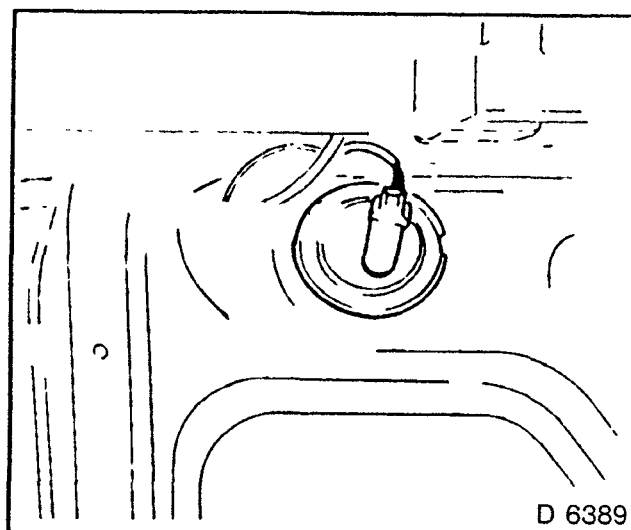


Fig. 11

For plastic fuel tank sensor with protective cover:

### REMOVE, DISCONNECT

1. Protective cover (1) together with wiring plug (2).

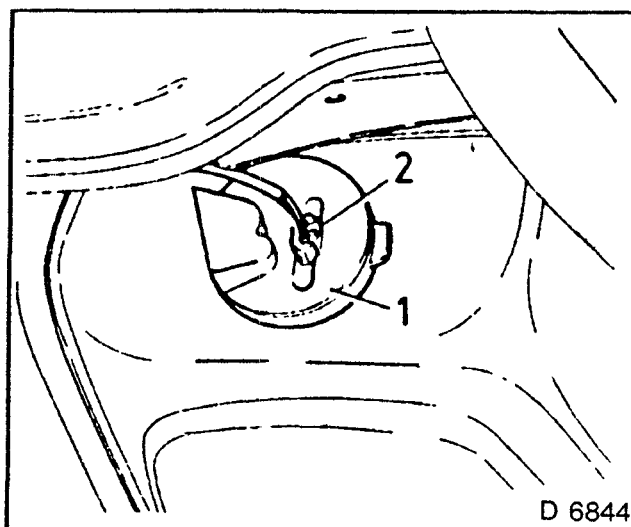


Fig. 12

### NOTE:

**MARK FUEL TANK SENDER UNIT INSTALLATION POSITION.**

### REMOVE, DISCONNECT

1. Fuel tank sender unit with KM-332-B.
2. On vehicles with petrol injection engine remove sender unit carefully (float arm routed around pump reservoir).

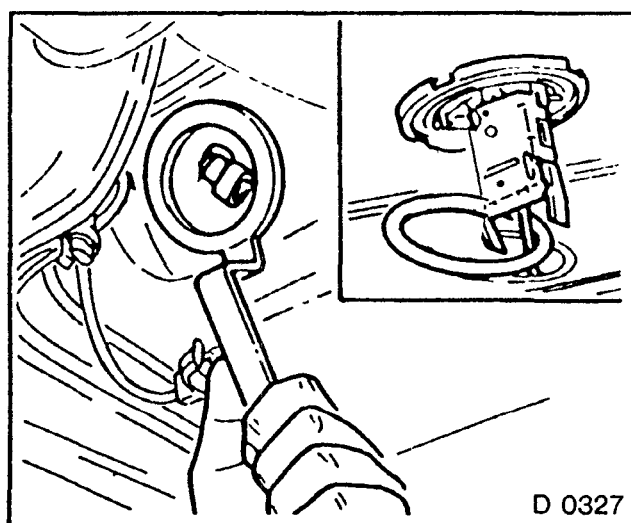


Fig. 13

**INSTALL, CONNECT**

- 1 Protective cover (1) together with wiring plug (2).

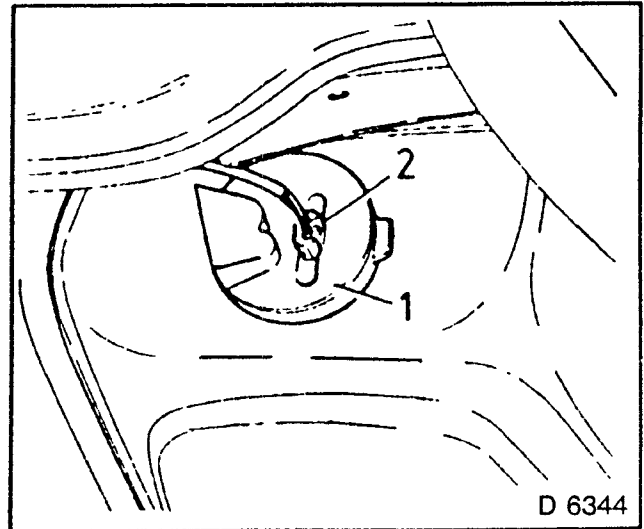


Fig. 14

**Fuel Tank —  
Remove and Install**

1. Drain fuel tank.
2. Guide hose through fuel filler pipe into fuel tank.
3. Pump off fuel with vehicles own fuel pump or external fuel pump and collect in suitable, clean container.

**WARNING:**

**OBSERVE SAFETY REGULATIONS AND  
LOCAL REGULATIONS.**

**REMOVE, DISCONNECT**

1. Fuel filler pipe.
2. Fuel tank sender unit wiring harness plug.
3. Electric fuel pump wiring harness plug (fuel injection models).

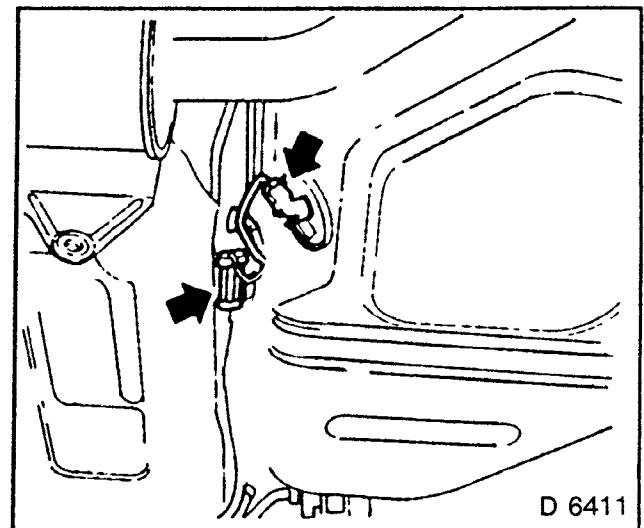


Fig. 15

**REMOVE, DISCONNECT**

1. Close fuel hoses with spring clips
2. Fuel feed and fuel return lines.
3. Fuel filter

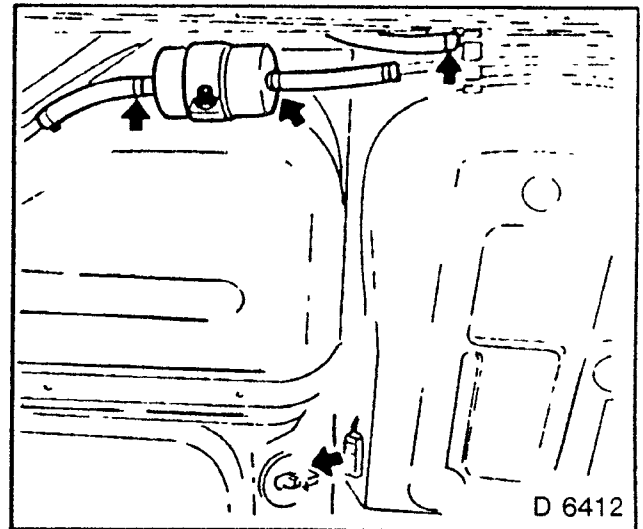


Fig. 16

4. Parking brake cables.

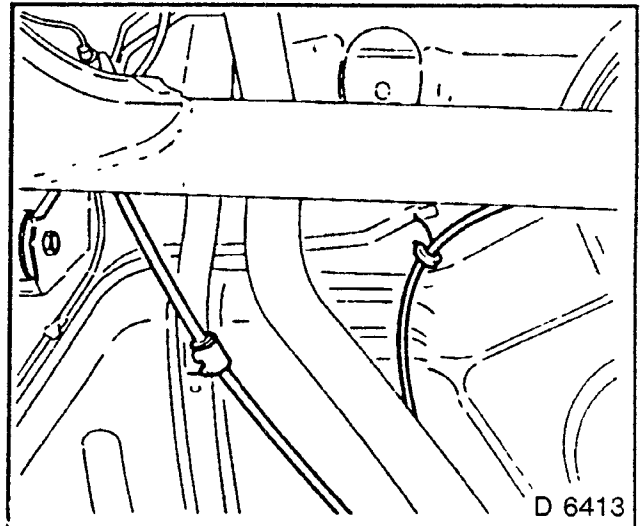


Fig. 17

5. Centre muffler
6. Rear muffler.

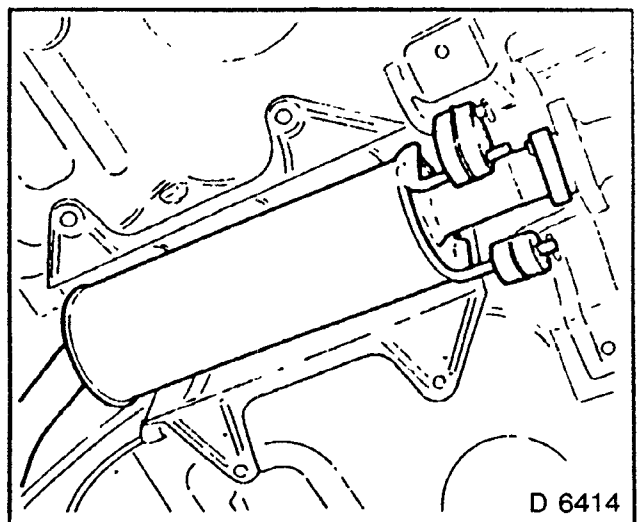


Fig. 18

- 7 Support fuel tank with hydraulic jack and suitable buffer piece.
8. Both straps from underbody
9. Lower fuel tank slightly.
- 10 Fuel hoses.
11. Vent hoses from fuel tank.
- 12 Lower fuel tank carefully and remove.

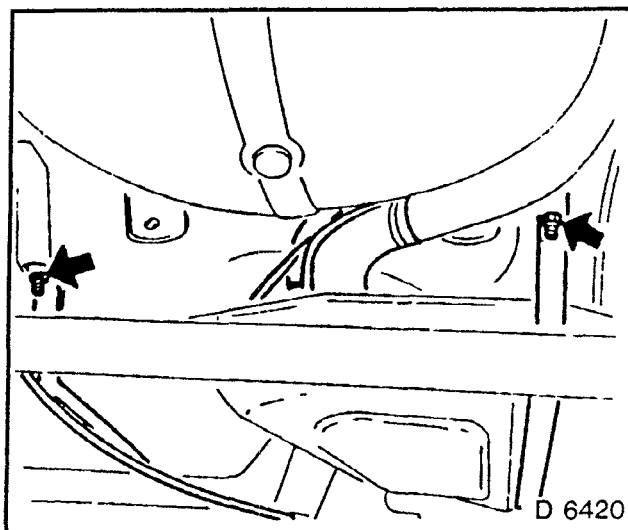


Fig. 19

## INSTALL, CONNECT

- 1 Fuel tank.
2. Fuel hoses.
3. Vent hoses to fuel tank.
4. Straps — tightening torque 20 Nm.

Note rubber damper, perfect layout of hoses and wiring.

Use new hose clips.

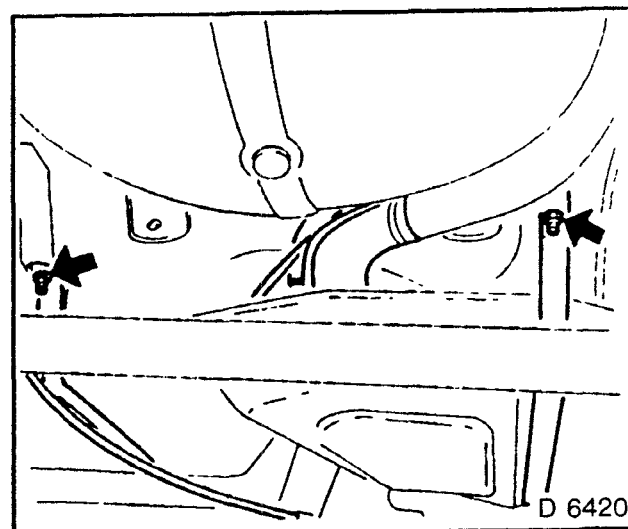


Fig. 20

- 5 Centre muffler.
6. Rear muffler.
- 7 Front section of exhaust system.

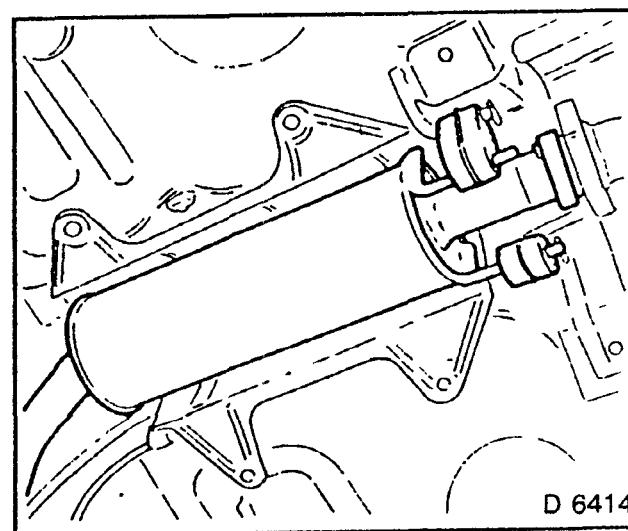


Fig. 21



- 8 Attach parking brake cables.

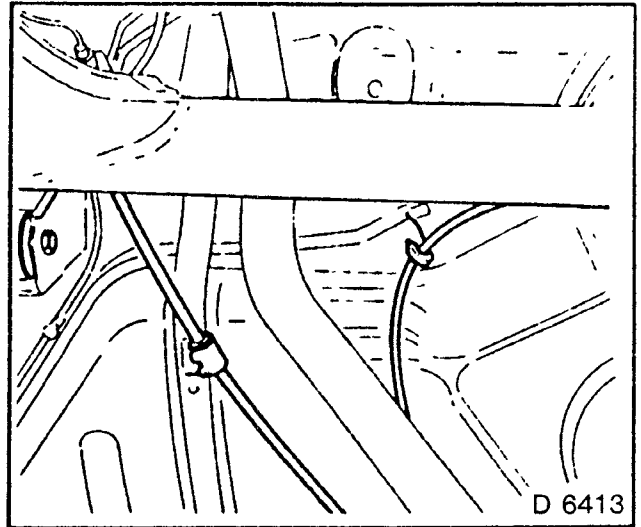


Fig. 22

9. Fuel filter.  
 10. Fuel feed and return lines.  
 11. Remove spring clips.  
 12. Use new hose clips.

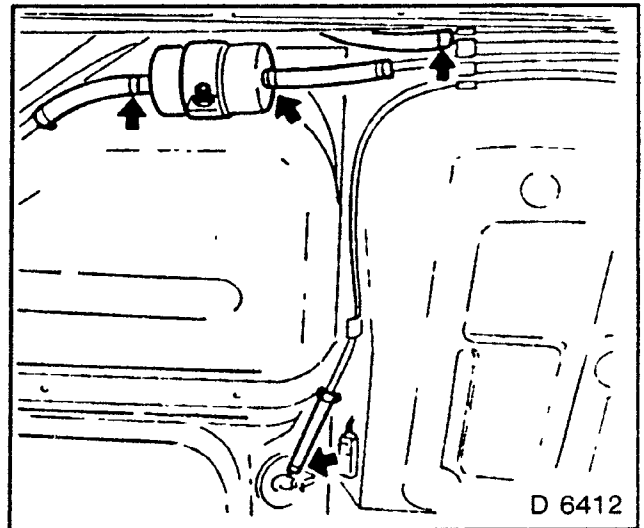


Fig. 23

- 13 Electric fuel pump wiring harness plug (if present).  
 14. Fuel tank sender unit wiring harness plug.  
 15. Fuel filler pipe.  
 16. Top up drained fuel again.  
 17 Tank lid (under rear seat).

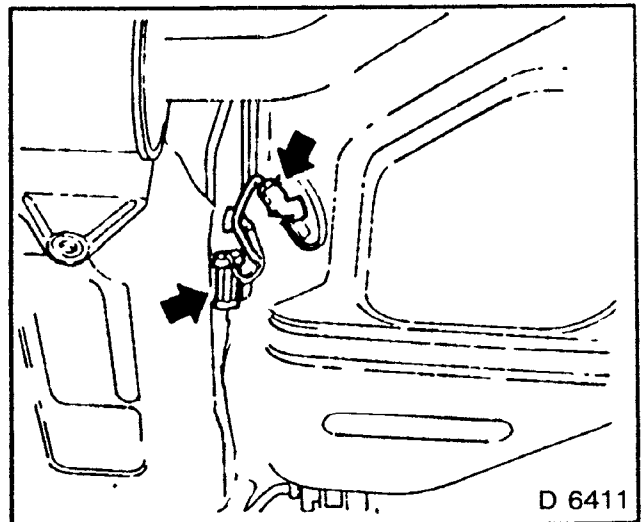
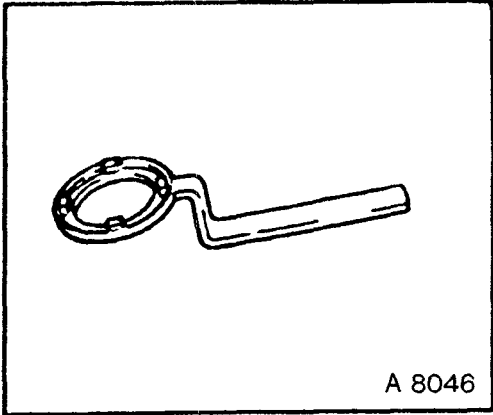


Fig. 24

# Special Service Tools

**KM — 332 B REMOVER/INSTALLER.**

To remove and install fuel tank sender unit.



## Technical Data Fuel System

|                            |                                  |   |                                |         |                                   |           |        |
|----------------------------|----------------------------------|---|--------------------------------|---------|-----------------------------------|-----------|--------|
| Engine version             | 14 NV                            | C 16 SE   | C 16 NZ                        | C 18 SE | C 20 SEH                          | C 20 XELN | 20 LET |
| Fuel tank.<br>Position     | Underneath rear seat pan         |   |                                |         |                                   |           |        |
| Filler opening             | Right rear quarter panel         |   |                                |         |                                   |           |        |
| Filling quantity in litres | 55ℓ                              |   |                                |         |                                   |           |        |
| Ventilation                | Open                             |   |                                |         |                                   |           |        |
| Fuel pump:<br>Design       | Diaphragm<br>pump,<br>mechanical | Inner gear<br>pump,<br>electrical                   | Turbine<br>pump,<br>electrical |         | Inner gear<br>pump,<br>electrical |           |        |
| Position                   | 1)                               | In fuel tank  |                                |         |                                   |           |        |
| Feed pressure kPa/rpm      | 25-36/1950                       |   | —                              |         |                                   |           |        |
| System pressure            | kPa                              | —   | 300                            | 100     | 300                               |           |        |
| Fuel filter:<br>Design     | Screen                           | Screen and pollen filter                            |                                |         |                                   |           |        |
| Position                   | 2)                               | Screen in fuel tank, pollen filter in pressure line |                                |         |                                   |           |        |

1) Engine right, camshaft housing

2) Fuel tank, fuel pump, carburettor

## Recommended Torque Values — Fuel System

|   | Nm               |
|---|------------------|
| Fuel filler pipe to rear frame . . . . .                            | 12.5             |
| Fuel filler pipe to rear quarter panel . . . . .                    | 2.5              |
| Fuel filter to fuel tank . . . . .                                  | 10               |
| Fuel pump to camshaft housing (14 NV).....                          | 18               |
| Fuel pump to fuel tank.....   | 2.5              |
| Fuel tank sender unit to fuel tank.....                             | 2.5              |
| Fuel tank strap to underbody.. . . . .                              | 20               |
| Bracket to front exhaust pipe support . . . . .                     | 20 <sup>2)</sup> |
| Fantail manifold heat shield to cylinder head (C 20 XELN) . . . . . | 9                |
| Fantail manifold to cylinder head (C 20 XELN) . . . . .             | 22               |
| Front exhaust pipe support to engine.....                           | 35               |
| Front exhaust pipe support to front exhaust pipe . . . . .          | 35               |
| Heat shield to underbody . . . . .                                  | 2 <sup>1)</sup>  |

1) Use new nuts

2) In connection with automatic transmission

# **Opel Astra** **Opel Kadett**

## **Workshop Manual**

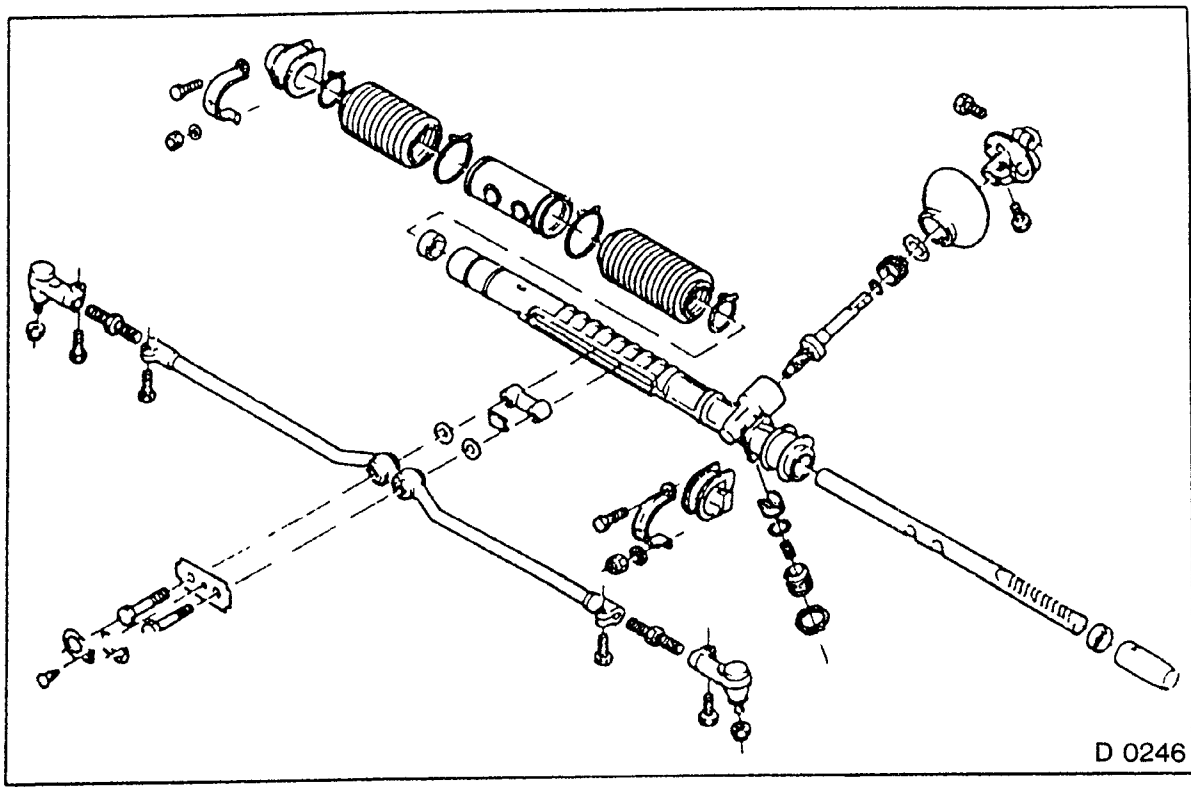
### **Section M**

### **Steering**

# Index

|   | <i>Page</i> |
|---|-------------|
| <b>CHECKING AND ADJUSTING OPERATIONS</b>                |             |
| FLUID PRESSURE CHECK.....                               | M- 8        |
| HYDRAULIC SYSTEM, BLEED..                               | M- 7        |
| STEERING ADJUST .                                       | M-20        |
| STRAIGHT AHEAD POSITION, CHECK/ADJUST.....              | M- 6        |
| <b>STEERING GEAR</b>                                    |             |
| FOLDING COVER ON STEERING GEAR, REPLACE.....            | M-26        |
| STEERING GEAR, OVERHAUL.....                            | M-20        |
| STEERING GEAR, REMOVE AND INSTALL .....                 | M-10        |
| STEERING GEAR, SEAL — POWER STEERING. ....              | M-20        |
| <b>STEERING LINKAGE</b>                                 |             |
| TIE ROD END, REPLACE.....                               | M-27        |
| TIE ROD, REPLACE .                                      | M-27        |
| <b>STEERING WHEEL</b>                                   |             |
| STEERING WHEEL/SLIP RING, REPLACE .....                 | M-29        |
| <b>STEERING COLUMN</b>                                  |             |
| STEERING COLUMN ASSEMBLY, REMOVE AND INSTALL..          | M-31        |
| DISC JOINT, REPLACE. .                                  | M-39        |
| STEERING COLUMN ASSEMBLY, DISASSEMBLE AND ASSEMBLE. . . | M-33        |
| STEERING COLUMN WITH FIXED STEERING WHEEL ...           | M-33        |
| STEERING COLUMN WITH HEIGHT ADJUSTABLE STEERING WHEEL.. | M-35        |
| STEERING COLUMN, REPLACE . .                            | M-39        |
| UPPER STEERING SHAFT, REPLACE.....                      | M-39        |
| UPPER STEERING SHAFT BALL BEARING, REPLACE .....        | M-30        |

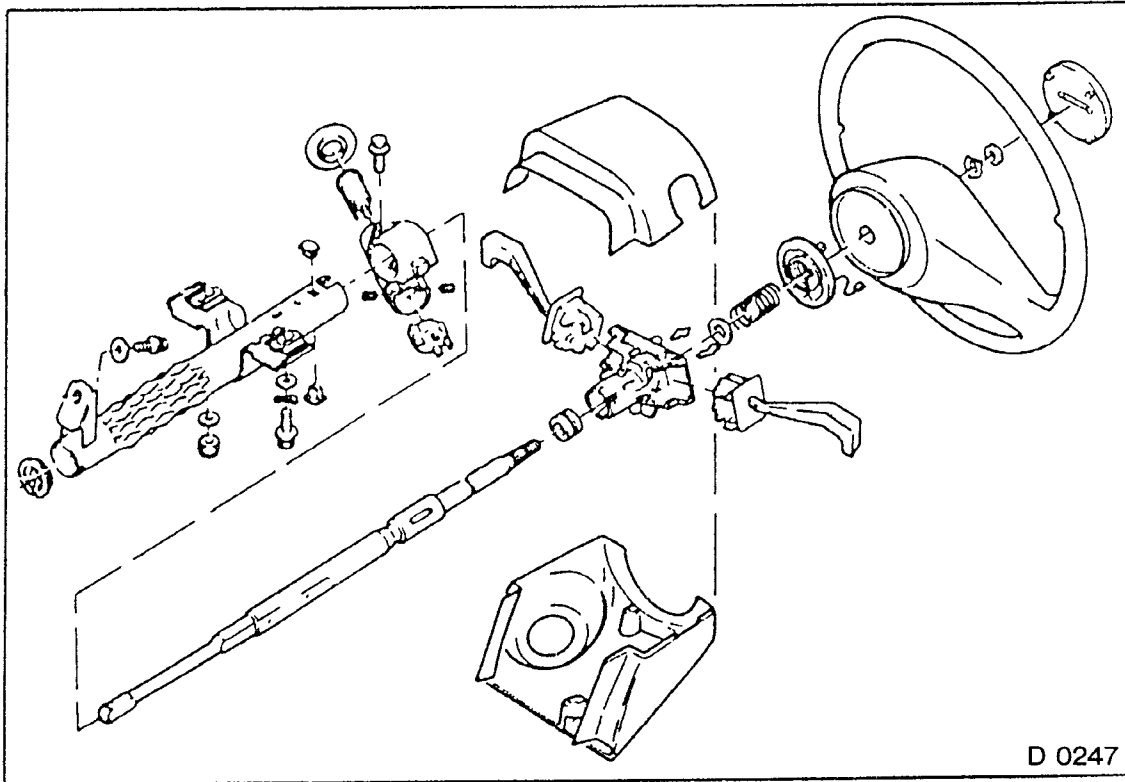




D 0246

Fig. 1 — Manual Steering Gear Assembly





D 0247

Fig. 2 — Steering Column Assembly

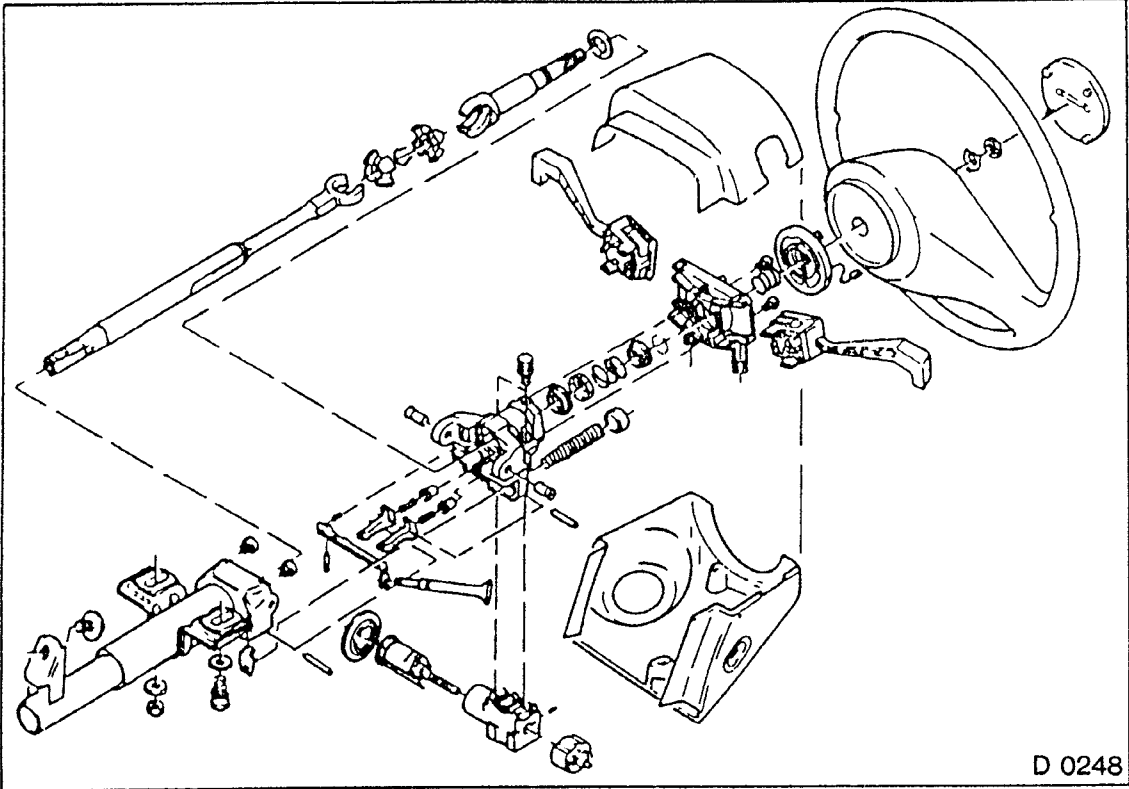


Fig. 3 — Steering Gear Assembly — Height Adjustable Steering Wheel

## CHECKING AND ADJUSTING OPERATIONS

### Straight Ahead Position, Check/Adjust

#### CAUTION:

After each and every operation on the steering gear or on the steering column assembly (removal and installation or disassembly and assembly), the exact straight ahead position of the steering must be checked.

Straight ahead position is attained when the reference dimension (1) = 325 mm

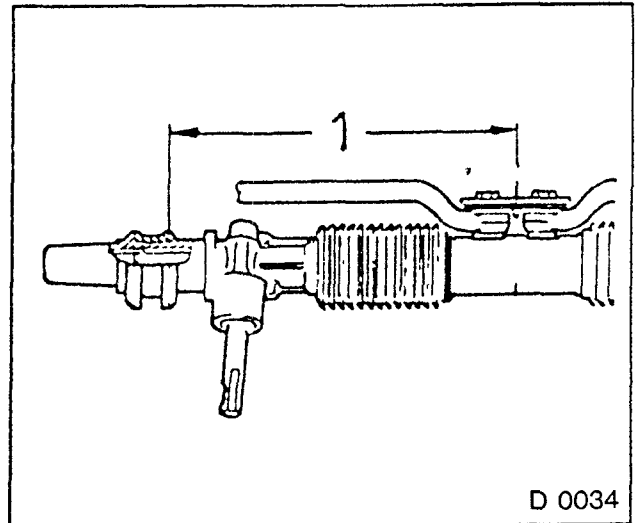


Fig. 4

#### INSPECT

- 1 Place Reference Gauge KM-476 between tie rod end and left steering gear housing offset fastening.

In this precise straight ahead position.

- A) The clamp flange bolts for the steering shaft should lie horizontally on top.
- B) The steering wheel spokes should slant downwards from centre.

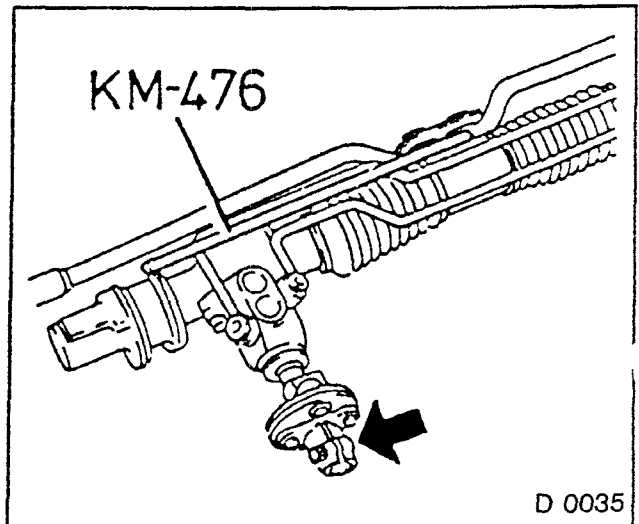


Fig. 5

#### ADJUST

1. When clamp flange bolt is positioned diagonally Fig. 6 — e.g. pinion misplaced by one tooth on steering rack (installation fault) — steering pinion position must be corrected immediately.
2. When steering wheel deviates from centre by more than 5° (clamp flange bolt must lie on top and horizontally), remove steering wheel from steering shaft using KM-210-A, and set centrally on shaft teeth.

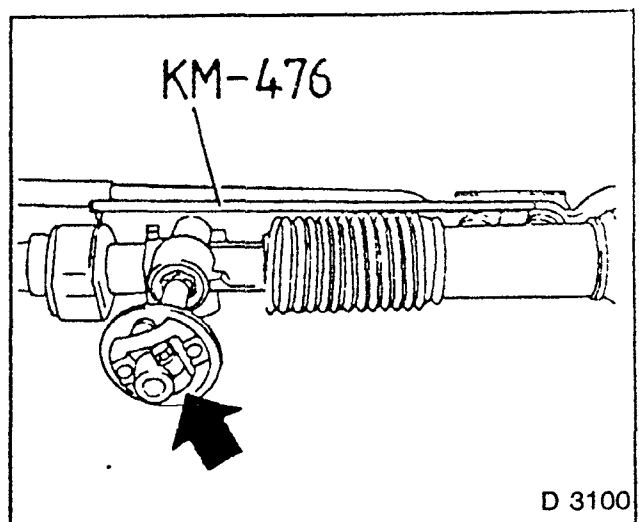


Fig. 6

## Hydraulic System, Bleed

### INSPECT

- 1 The stationary engine is initially filled up with fluid to MAX mark (1).
2. Start engine and immediately top up fluid to lower MIN mark (2).

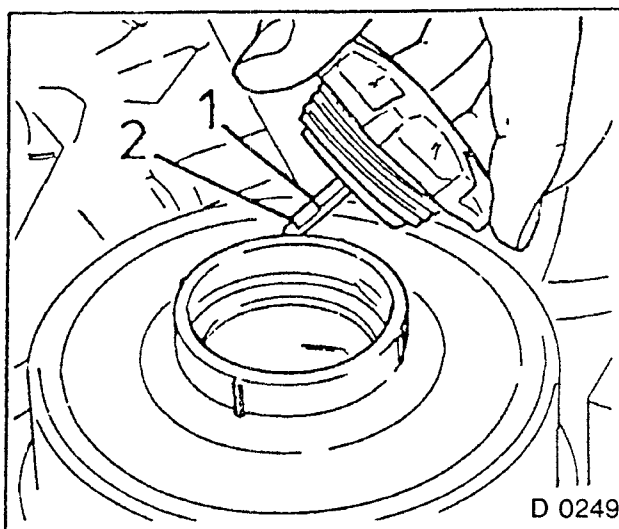


Fig. 7

### CAUTION:

**THE FLUID PUMP MUST NOT BE ALLOWED TO RUN DRY.**

1. Turn steering wheel two to three times approximately 45° slowly to left and right and twice from stop to stop.
2. Correct fluid level in fluid reservoir again.
- 3 Switch of engine and check fluid level. Fluid at operating temperature — approximately 80°C/176°F to MAX (1). Fluid cold — approximately 20°C/68°F to MIN (2).

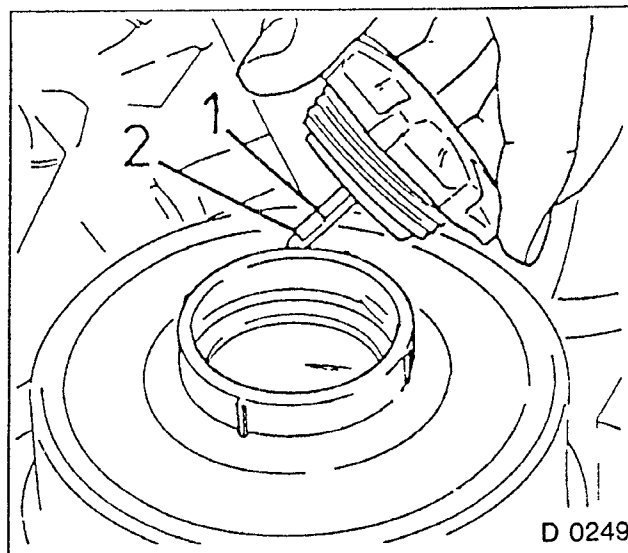


Fig. 8

### NOTE:

**FLUID SHOULD ONLY BE USED ONCE.**

Fluid quality: See Technical Data Page 56.

Use dipstick from fluid reservoir cover to check fluid level

## Fluid Pressure — Check

### INSPECT

1. Fluid pressure.
2. Connect Fluid Pressure Measuring Instrument KM-354-B to fluid circuit pressure hose.

### NOTE:

**FLUID ESCAPES. TOP UP BEFORE PRESSURE CHECK.**

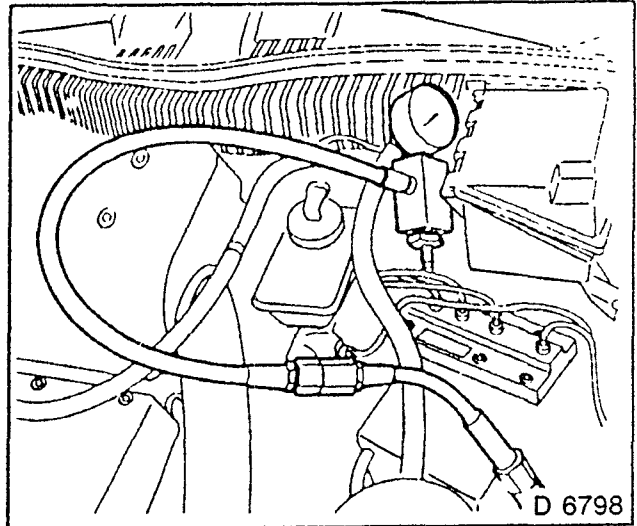


Fig. 9

### INSPECT

When the shut-off valve is open, the fluid pressure measuring instrument in steering mid-position shows a pressure of only a few kPa.

When steering wheel is turned to the left or right, pressure increases and attains at each full lock its highest value (see Technical Data Page 56). A smaller difference in pressure at left full lock compared to right is of no significance.

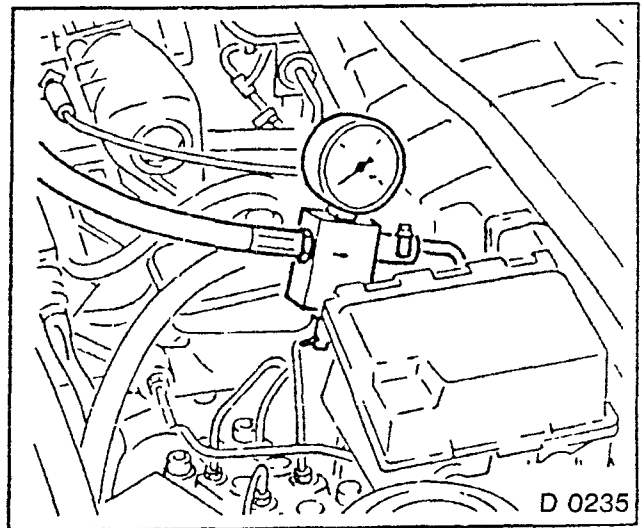


Fig. 10

### CAUTION:

**NEVER PULL STEERING WHEEL LONGER THAN 10 SECONDS AGAINST THE STOP.**

### MEASURE

1. Read maximum pressure accurately with measurement instrument's shut-off valve open and with steering wheel turned to right and left stop.
2. Close shut-off valve, steering in mid-position, and read maximum pressure.

**NOTE:**

When shut-off valve is closed, pump continues operating with maximum pressure. Close shut-off valve for short periods of time only, while reading off manometer simultaneously (ten seconds maximum). Compare both maximum pressures with one another.

If maximum pressure with shut-off valve closed is noticeably greater than at steering wheel stop; steering gear hydraulics are faulty.

If maximum pressure with shut-off valve closed is less than as given in Technical Data, fluid pump is faulty.

## Steering Gear — Remove and Install

### REMOVE, DISCONNECT

1. Ground cable from battery.
2. Pre-volume chamber — DOHC engines only.

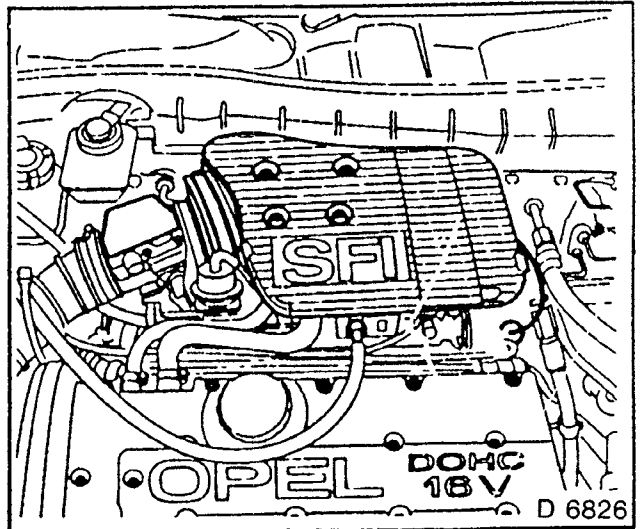


Fig. 11

3. Put front wheels in straight-ahead position.

### REMOVE, DISCONNECT

1. Both tie rods (1) from steering gear.
2. Twist protector bolts (A), spacer (B) and washers (C).

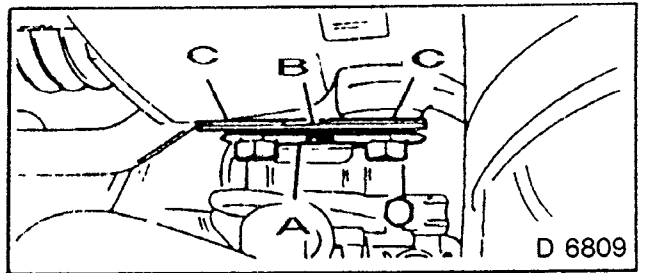


Fig. 12

### REMOVE, DISCONNECT

1. Left front wheel.
2. Left tie rod end (1) from tie rod lever (2) — KM-507-C.

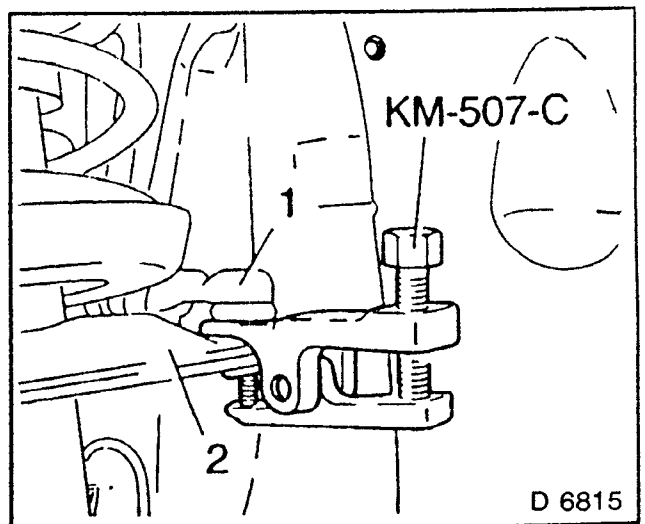


Fig. 13

**REMOVE, DISCONNECT**

- 1 Footwell panelling.
- 2 Put steering gear in straight-ahead position.
- 3 Loosen steering coupling (arrows), push up.

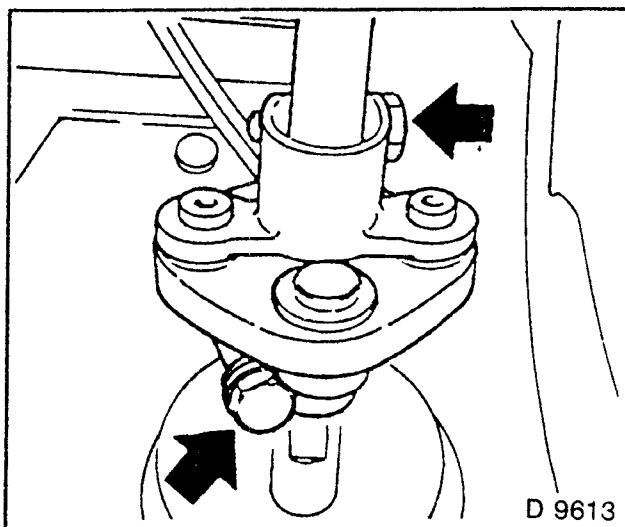


Fig. 14

**REMOVE, DISCONNECT**

1. Brake lamp switch.
2. Brake pedal spring.
3. Retainer (1).
4. Piston rod pin from fork.

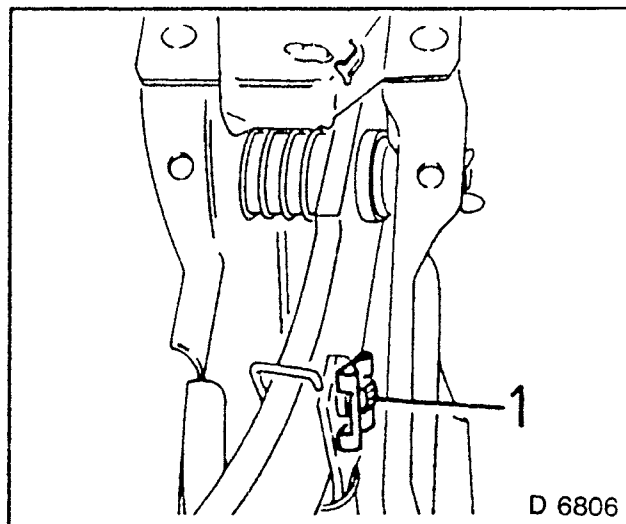


Fig. 15

**REMOVE, DISCONNECT**

1. Clamps from servo lines — for power steering.

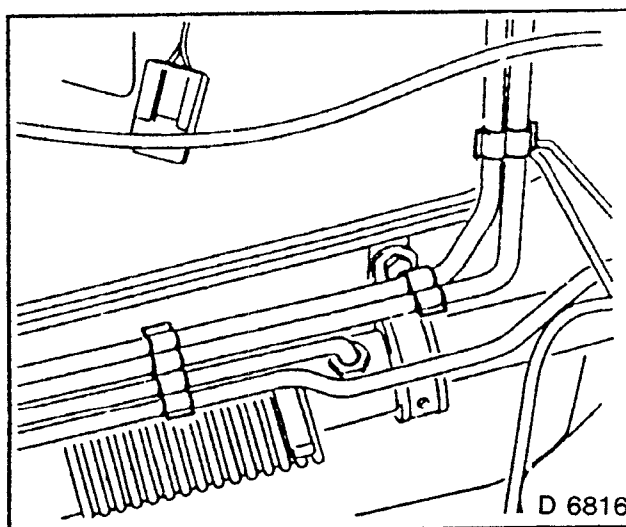


Fig. 16



**REMOVE, DISCONNECT**

- 1 Coolant compensation tank.
2. Remove wiring plug (1).
3. Remove hoses (2).
4. Close off connections.

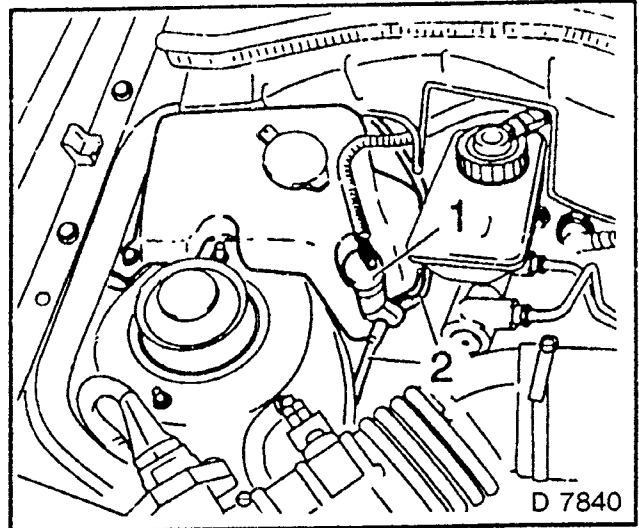


Fig. 17

**REMOVE, DISCONNECT**

- 1 Remove brake fluid reservoir wiring plug.
2. Top up brake fluid reservoir to mark "MAX" and close off with blind screw cap (1).
3. Brake lines (2) from brake master cylinder (3).
4. Brake master cylinder (arrows).

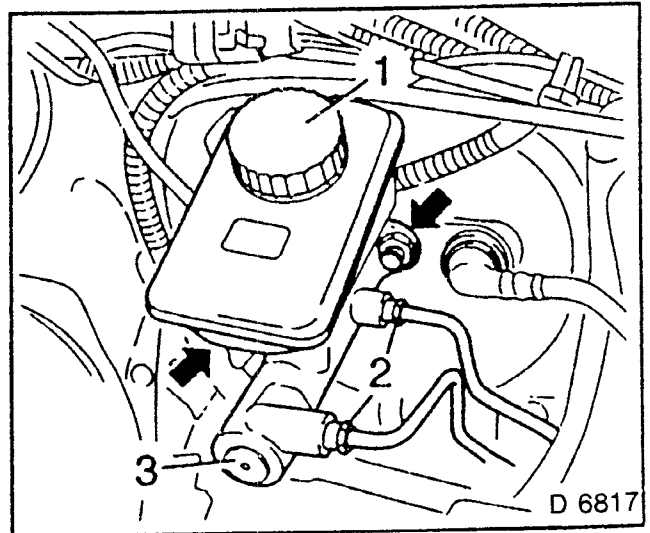


Fig. 18

**REMOVE, DISCONNECT**

1. Brake lines (1) from bulkhead bracket (2).
2. Vacuum line (3) from brake servo.

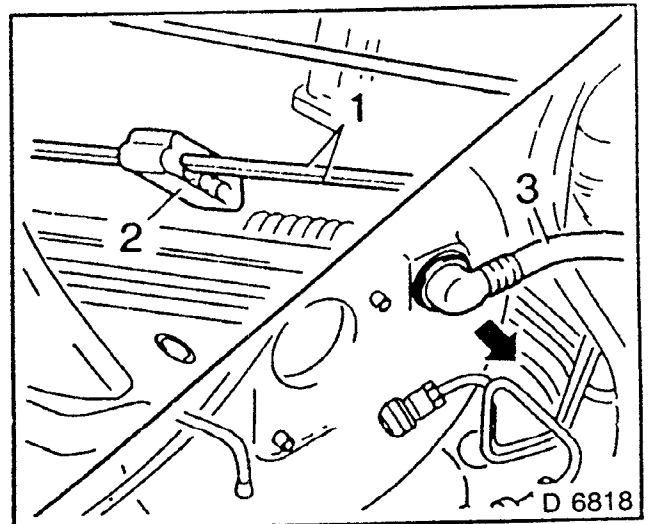


Fig. 19

3. Cowl panelling.
4. Screen wiper motor with linkage.
5. Closure plugs on bottom of cowl.

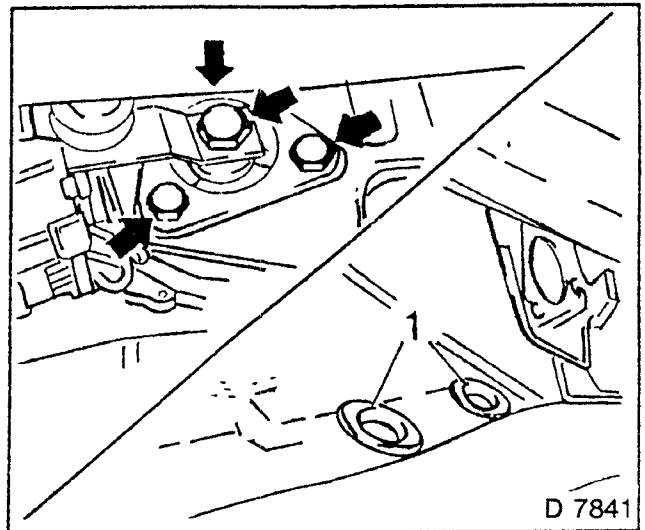


Fig. 20

### REMOVE, DISCONNECT

1. Brake servo
2. Fastening bolts for support through bottom of cowl.
3. Remove bolts.

### REMOVE, DISCONNECT

1. Brake servo with support from bulkhead.
2. Front support from brake servo.
3. Fork and hex nut from thrust rod.

### NOTE

**BRAKE SERVO AND SUPPORT ADHERE TO BULKHEAD, AS THEY ARE ATTACHED WITH SEALING COMPOUND.**

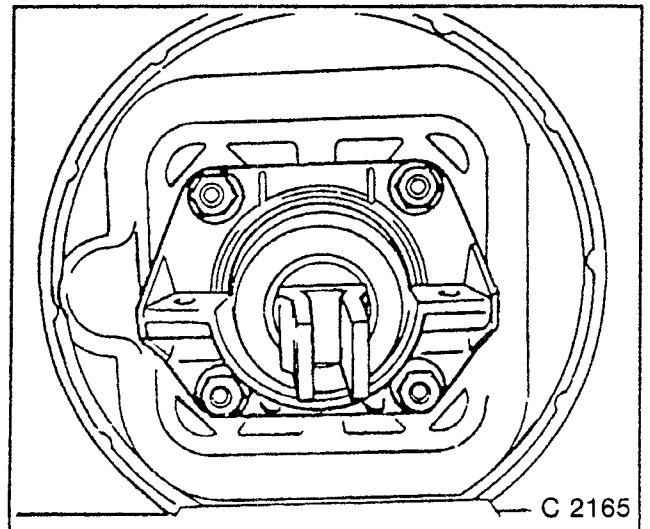


Fig. 21

### REMOVE, DISCONNECT

1. Connections (arrows) of pressure and return lines — with power steering.
2. Close off openings.
3. Unclip fastening clamps along lines.

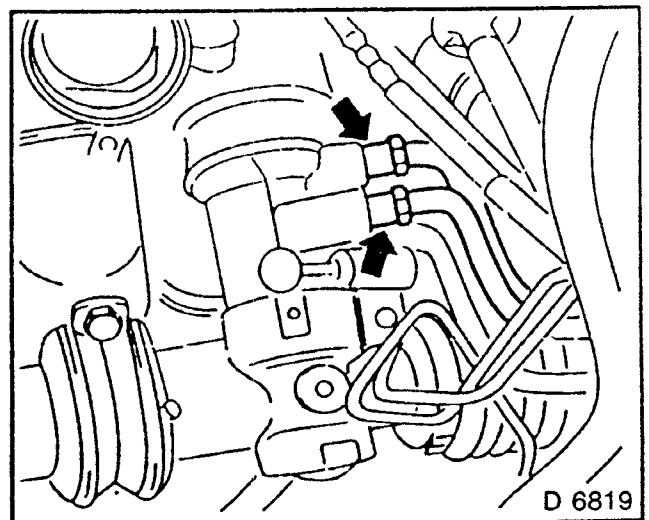


Fig. 22

**REMOVE, DISCONNECT**

1. Steering gear with retaining brackets from bulkhead (arrows).
2. Turn left spring strut to left.
3. Remove steering gear through left wheel housing.
4. Remove rubber buffer.

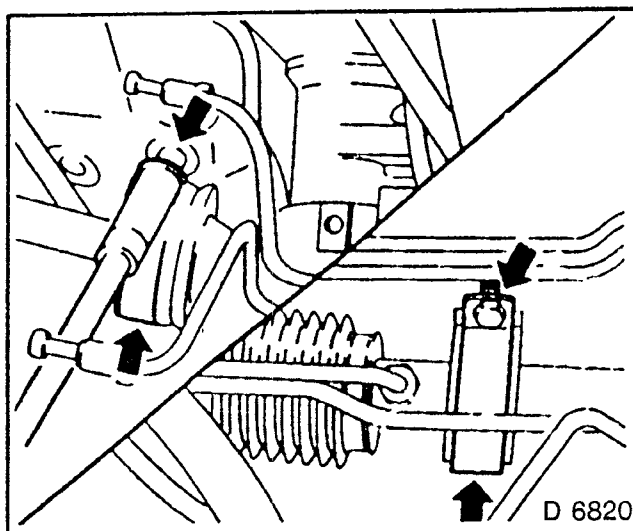


Fig. 23

5. Recut thread in bulkhead.
6. Place rubber buffer on steering gear.

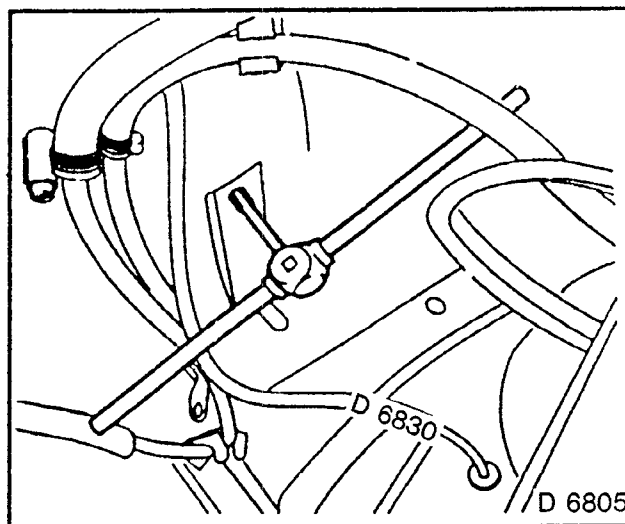


Fig. 24

7. Turn left spring strut to left.
8. Guide steering gear into engine compartment through left wheel housing.
9. Position steering gear with retaining brackets on bulkhead.
10. Use new nuts, insert bolts with Locking Compound. LOCKTITE 242.

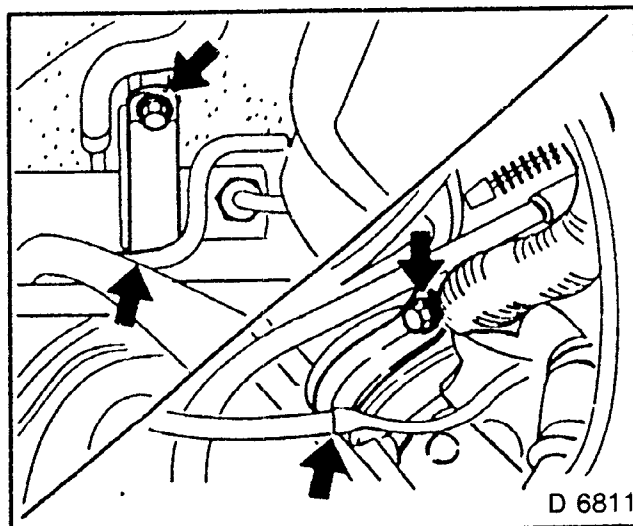


Fig. 25

**TIGHTEN (TORQUE)**

1. Steering gear with retaining brackets to bulkhead — 22 Nm
2. Observe straight-ahead position —  
Checking Gauge KM-476.

3. Pressure and return lines — 28 Nm —  
power steering.

**INSTALL, CONNECT**

1. Fastening clamps along lines — power  
steering.

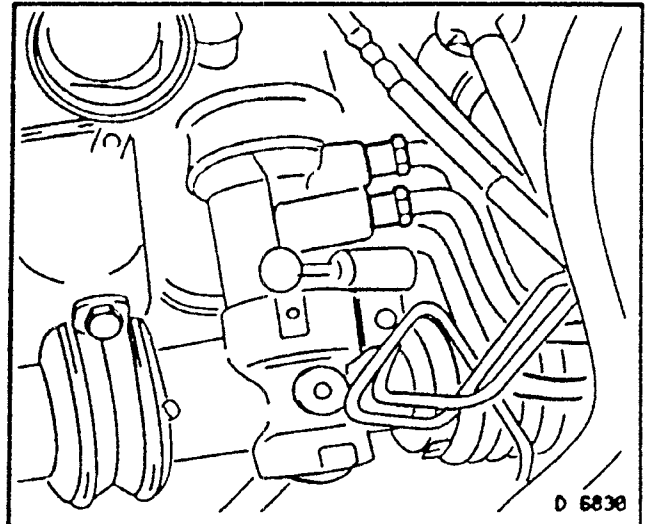


Fig. 26

**TIGHTEN (TORQUE)**

1. Both tie rods to steering gear — 95 Nm —  
with spacer and washers.
2. Secure tie rods with new twist protector.

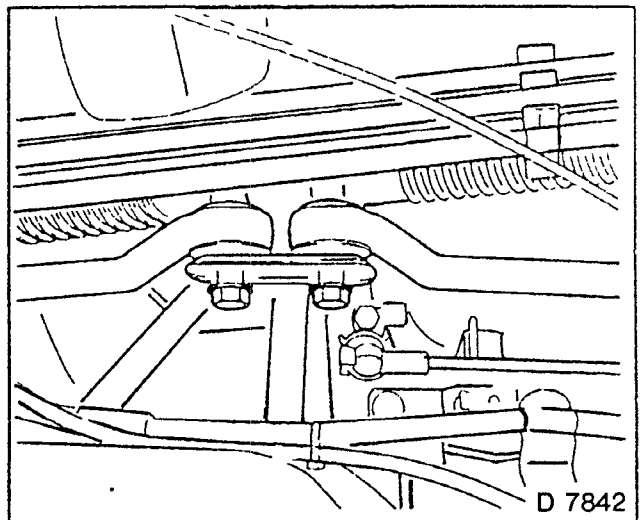


Fig. 27

3. Left tie rod end to tie rod lever — 60 Nm.
4. Left front wheel — 110 Nm

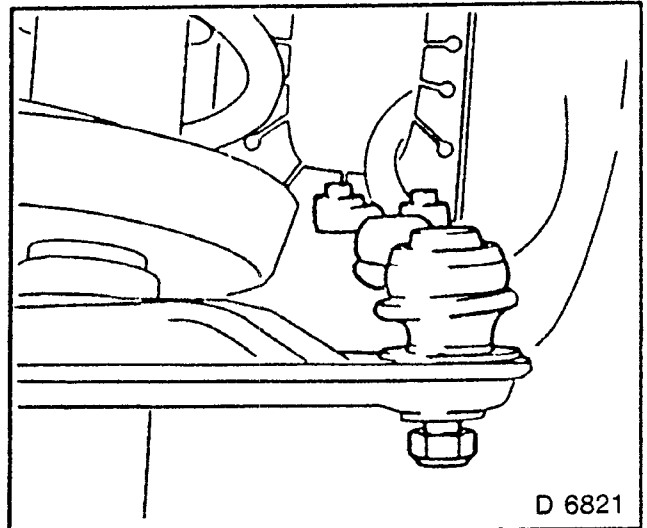


Fig. 28

5. Hex nut and fork on thrust rod — 18 Nm
6. Fork to dimension (1) — 147,7 mm.
7. First clamp new brake servo in vice.
8. Front retaining bracket to brake servo — 20 Nm

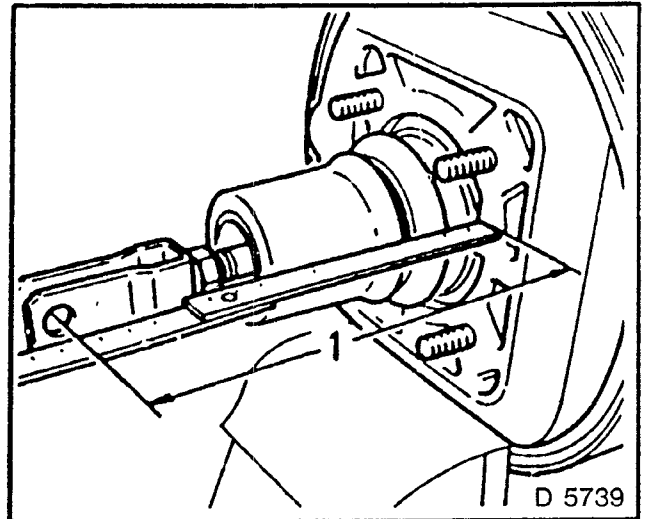


Fig. 29

## CLEAN

1. Clean contact surfaces for front and rear retaining brackets with benzine and coat with Adhesive Sealing Compound. L0000589.

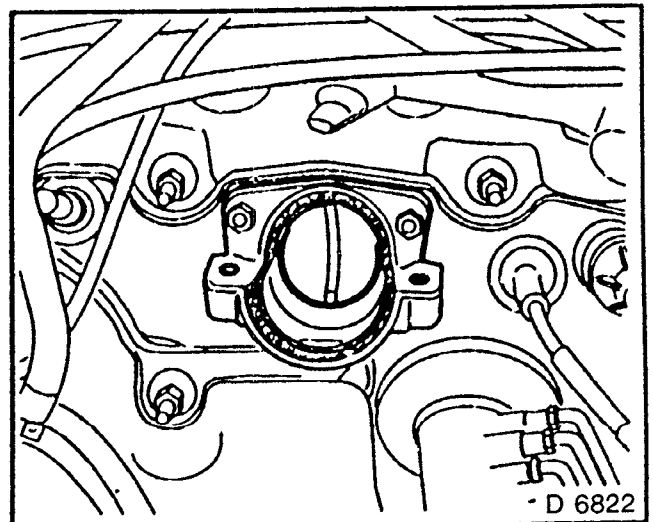


Fig. 30

**TIGHTEN (TORQUE)**

- 1 Brake servo with retaining bracket to bulkhead — 22 Nm
2. Coat fastening bolts thinly with Locking Compound LOCKTITE 242.

**INSTALL, CONNECT**

- 1 Closure plugs (1) on bottom of cowl.
2. Screen wiper motor (arrows).
3. Cowl panelling.

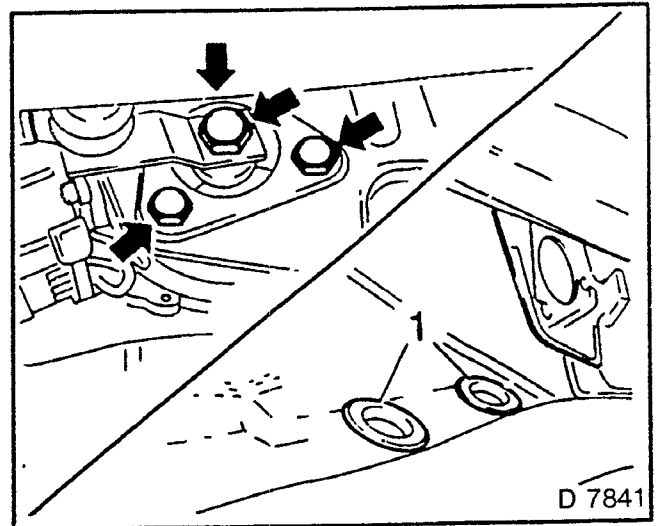


Fig. 31

**TIGHTEN (TORQUE)**

- 1 Brake master cylinder to brake servo — 22 Nm
- 2 Brake lines to brake master cylinder — 16 Nm

**INSTALL, CONNECT**

1. Vacuum pipe in brake servo.

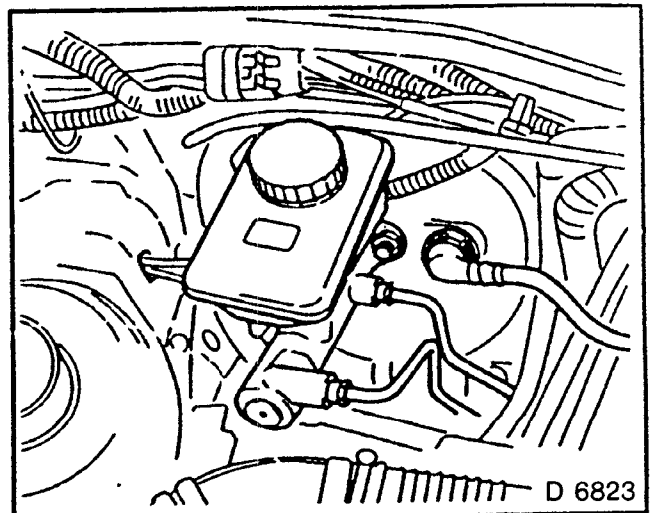


Fig. 32

2. Windscreen washer system fluid reservoir to wheel well — 2 Nm
3. Connect hoses and wiring plugs.

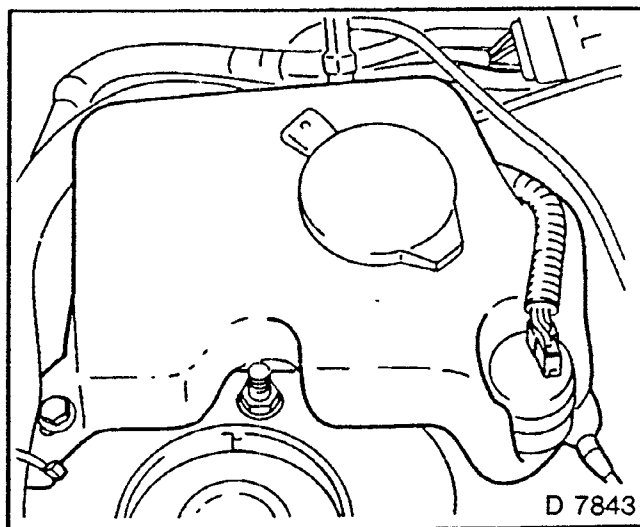


Fig. 33

4. Remove brake fluid reservoir blind screw cap.
5. Unscrew brake fluid float.
6. Connect wiring plug.

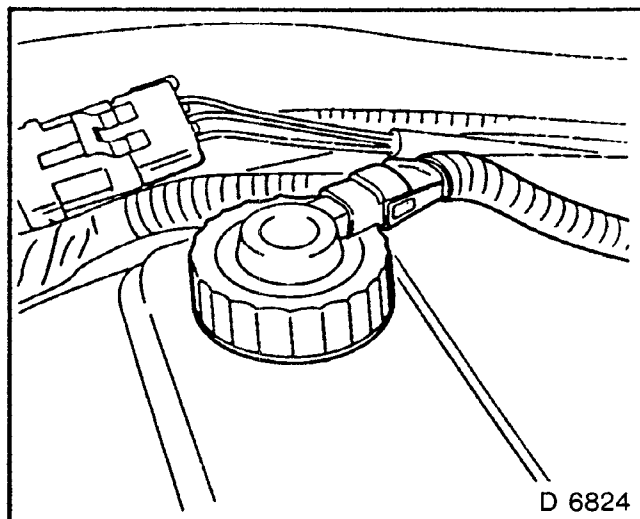


Fig. 34

### TIGHTEN (TORQUE)

- 1 Push steering coupling onto steering pinion.
- 2 Clamp bolt, steering pinion to steering coupling — 22 Nm
- 3 Clamp bolt, steering shaft to steering coupling — 22 Nm

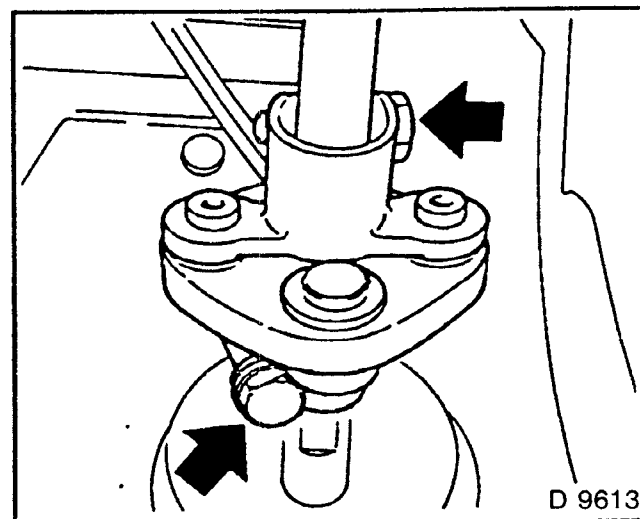


Fig. 35

**INSTALL, CONNECT**

1. Piston rod stud in fork.
2. Retainer (1).
3. Brake pedal spring.
4. Brake lamp switch.
5. Footwell panelling.

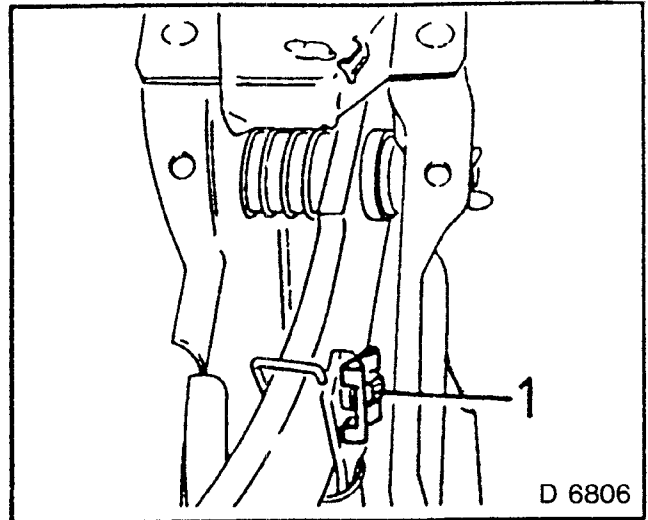


Fig 36

6. Pre-volume chamber — DOHC engines only (see Section J).
7. Ground cable to battery.
8. Bleed brake system and check for leaks (see Section H).
9. Check brake servo — (see Section H).

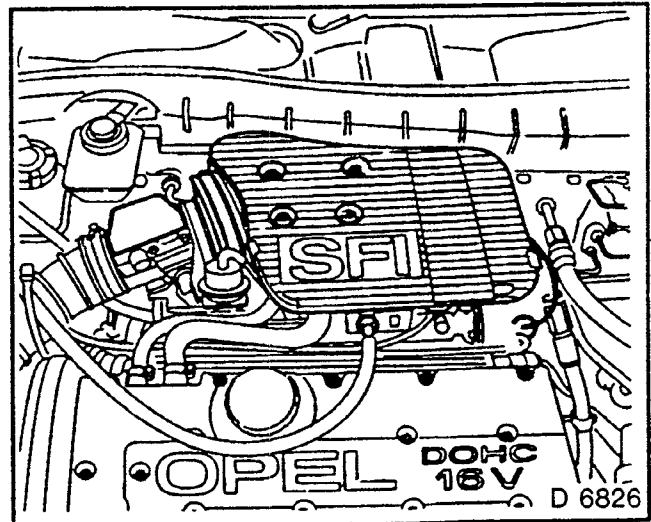


Fig. 37



## Steering Gear, Seal — Power Steering

### REMOVE, DISCONNECT

1. Brake servo
2. Pipe leads and also pressure and return line from steering gear.

### CLEAN

1. Sealing surfaces and lines.

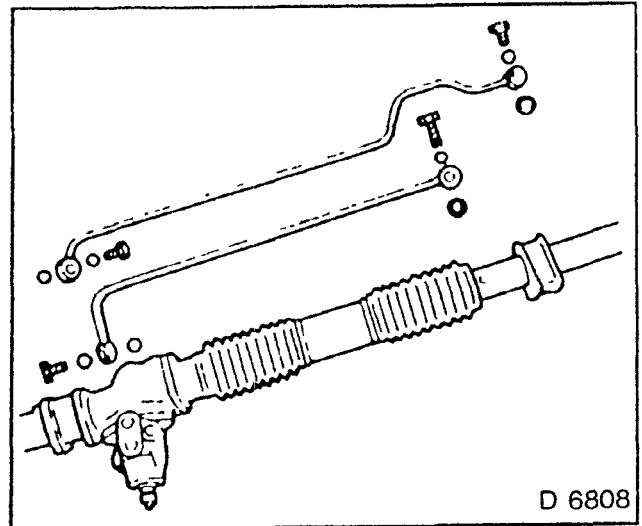


Fig. 38

### CAUTION:

**ALWAYS RENEW SEAL RINGS. SEALING OPERATIONS ARE TO BE CARRIED OUT WITH EXTREME CARE.**

### TIGHTEN (TORQUE)

1. Pipe lines to steering gear — 37,5 Nm  
Neither pipe line should lie against the folding covers.
2. Pressure and return line to steering gear — 28 Nm
3. Install brake servo.
4. Bleed hydraulic system and check for leaks.

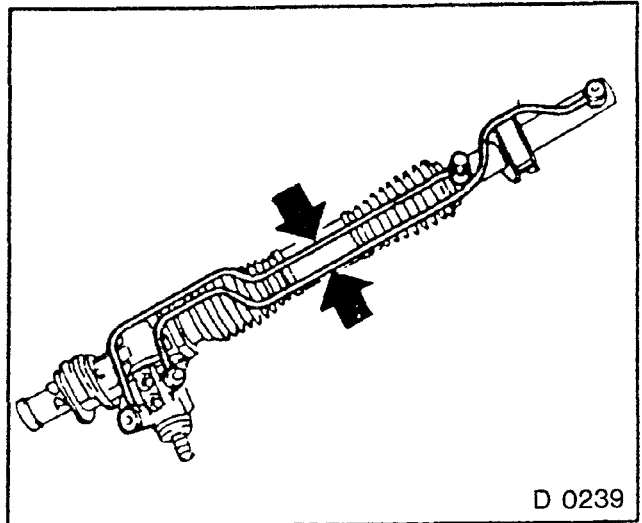


Fig. 39

## Steering, Adjust

See "Steering Gear, Overhaul".

## Steering Gear, Overhaul

### REMOVE, DISCONNECT

1. Steering gear.

**DISASSEMBLE**

1. Steering gear.
2. Rubber bearing rings with retaining bracket and bulkhead rubber seal from steering gear housing.
3. Both clamp wires from folding covers.
4. Both folding covers with housing pipe from steering gear housing.

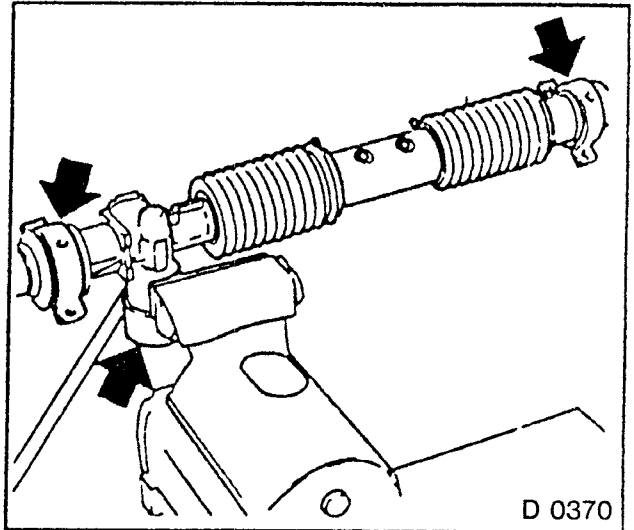


Fig. 40

5. Sliding piece and guide piece from steering rack.
6. Steel plate hex nut for adjustment screw —KM-472.

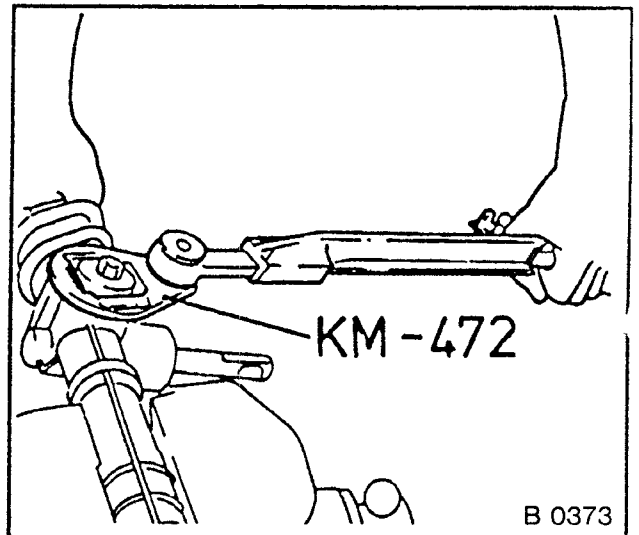


Fig. 41.

7. Unscrew adjustment screw.
8. Pressure spring from adjustment screw opening.
9. Steering gear.
10. Rubber bearing ring with retaining bracket and bulkhead rubber seal from steering gear housing.
11. Both clamp wires from folding cover.
12. Both folding covers with housing pipe from steering gear housing.

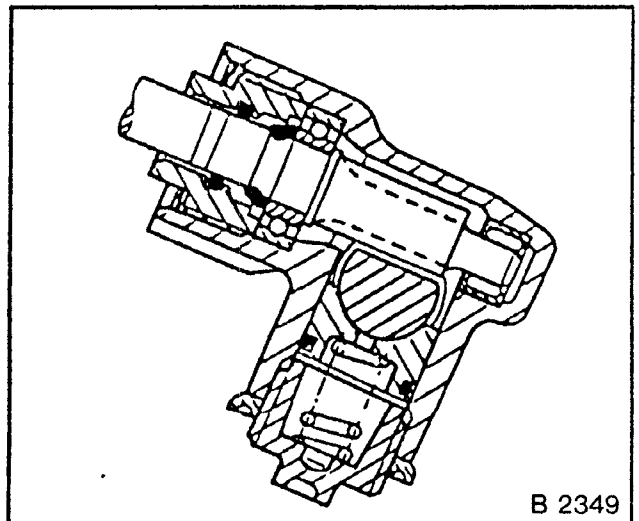


Fig. 42

13. Plate retaining ring, bolt for pinion fastening.
14. Replace bolt O-ring.

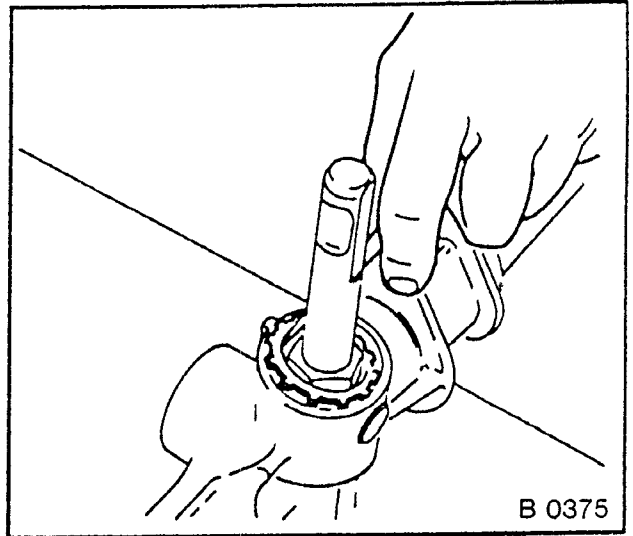


Fig. 43

15. Guide segment from adjustment screws opening.
16. Guide segment lies under suction in housing opening.
17. Replace O-ring.

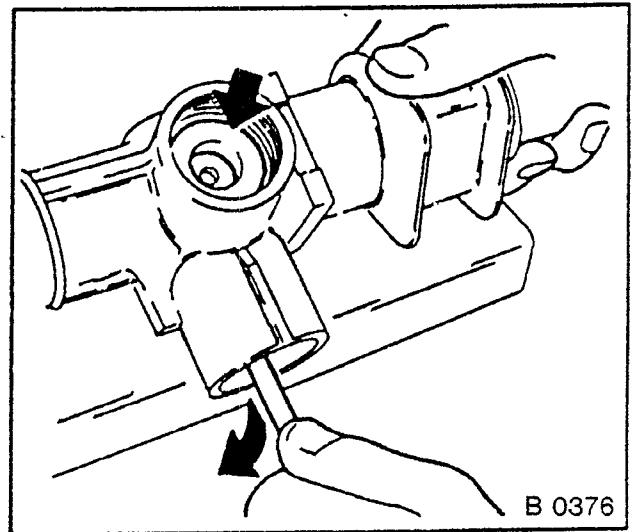


Fig. 44

18. Metal sealing cap from steering gear housing.

**NOTE:**

Further disassembly of the steering gear housing, and also removal of the steering racks bearing bushings and of the pinion needle bearings is not envisaged.

**CLEAN**

All parts.

**INSPECT**

1. Check all parts for wear and damage — if necessary replace.

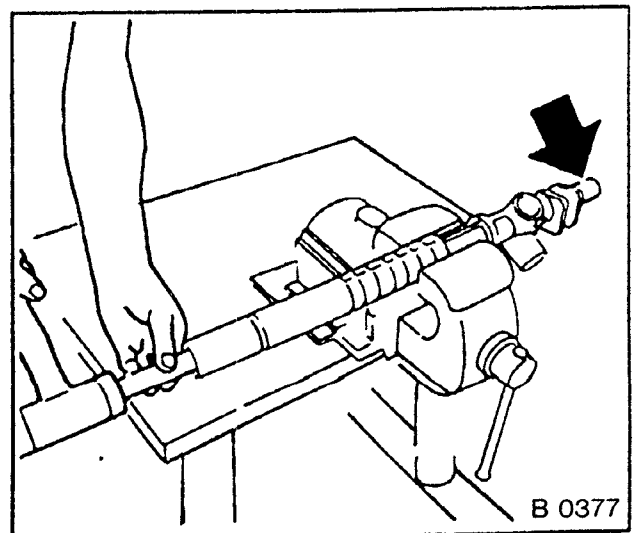


Fig. 45

- If steering racks bearing bushings or pinion needle bearing are damaged, always replace steering gear housing assembly

**NOTE:**

**WHEN REPLACING, NOTE TOTAL STEERING RATIO — SEE TECHNICAL DATA PAGE 56.**

**ASSEMBLE**

- Steering gear.
- Lubricate pinion and steering rack with Steering Grease.
- Fill interior of steering gear housing between steering rack bearings evenly with approximately 50 g steering grease.
- Steering rack and pinion in steering gear housing.

**MEASURE**

- Steering rack position — dimension (1) = 61 mm — between long steering gear housing end and steering rack facing surface.
- Longitudinal recess (arrow) on pinion shaft points towards left (straight ahead position of steering).

**TIGHTEN (TORQUE)**

- Fill cavity between bolt and pinion ball bearing with Anti-friction Bearing Grease. B0400852.
- Pinion fastening bolt to housing — 40 Nm
- Secure with plate retaining ring.

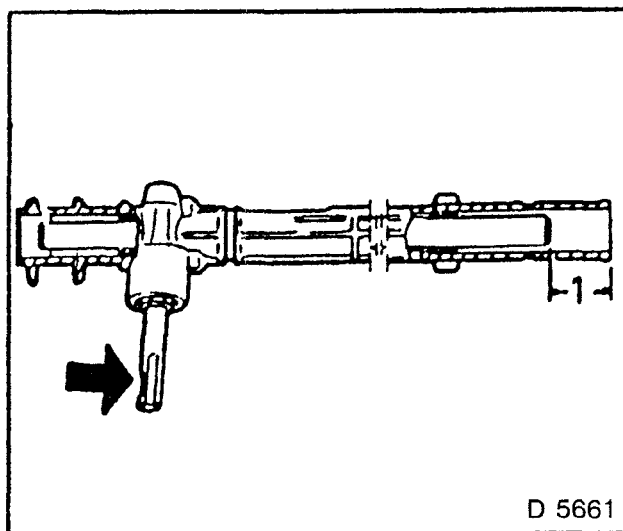


Fig. 46

**ASSEMBLE**

- 1 Drive in new retaining ring — KM-473

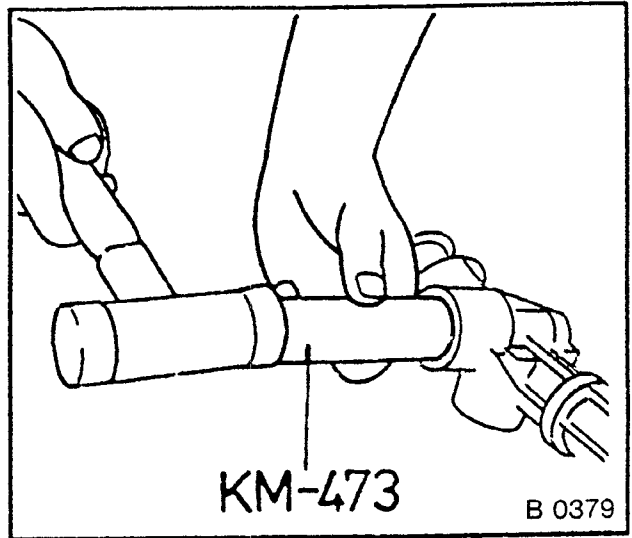


Fig. 47

**ADJUST**

- 1 Steering gear.
- 2 Screw on sliding and guiding pieces in conjunction with two spacer sleeves (1) with both tie rod fastening bolts to steering rack.

Spacer sleeve — 30 mm high, 25/12.5 mm diameter (own construction)

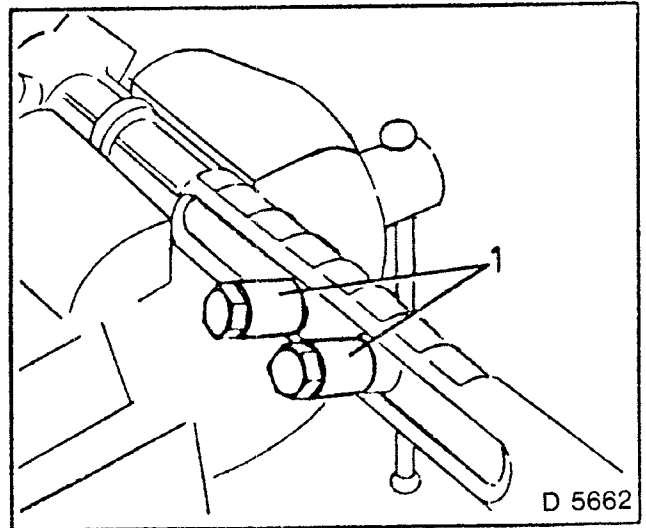


Fig. 48

- 3 Guide segment and pressure spring in adjustment screw opening.
- 4 Adjustment screw until resistance in steering gear housing is noticeable — Target value — 5 Nm (steering gear in straight ahead position).
5. Turn back adjustment screw 20° to 40°.

**INSPECT**

Free play of steering rack over whole range of pinion engagement.

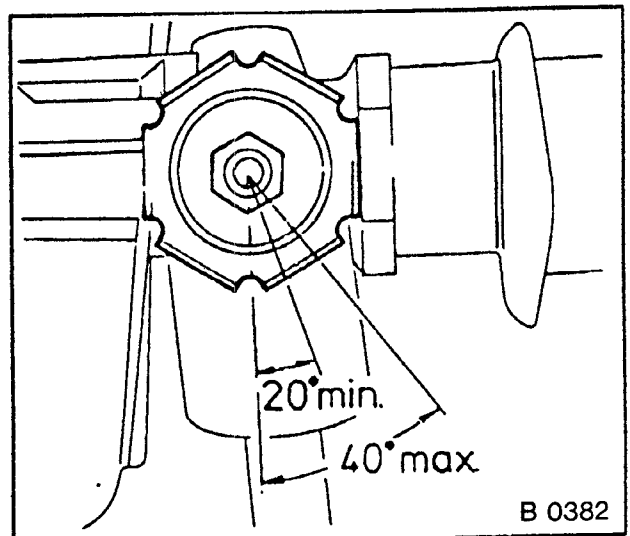


Fig. 49

**TIGHTEN (TORQUE)**

1. Counter nut with KM-472 — 60 Nm
2. Counterhold adjustment screw.

**NOTE:**

**AFTER INSTALLATION OF STEERING GEARS, ESTABLISH DURING TEST DRIVE WHETHER STEERING RETURNS ON ITS OWN ACCORD TO STRAIGHT AHEAD POSITION.**

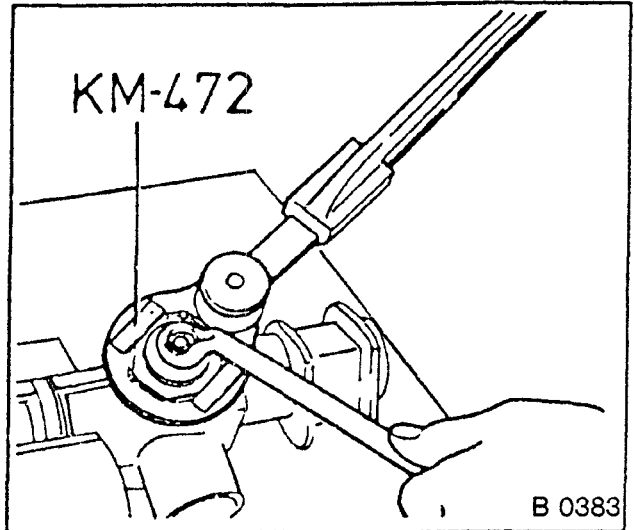


Fig. 50

**ASSEMBLE**

1. New metal sealing cap in short steering gear housing end.
2. Housing pipe and both folding covers on steering gear housing.
3. First unscrew both tie rod fastening bolts from steering rack.
4. Fasten both folding covers with clamp wires.
5. Ends of both wires, in steering gear installation position, point upwards

**CAUTION:**

**FOLDING COVER MUST NOT LIE TWISTED.**

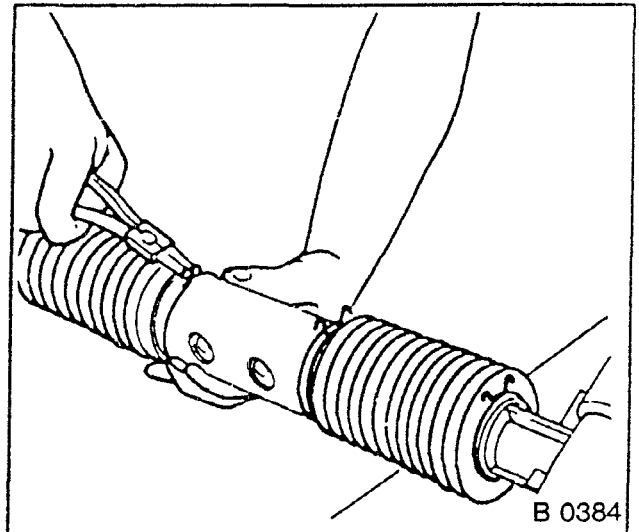


Fig. 51

**ASSEMBLE**

1. Rubber bearing rings with retaining bracket and bulkhead rubber cover on steering gear.
2. Inner curve on bracket flange points downwards.

**INSTALL, CONNECT**

- 1 Steering gear

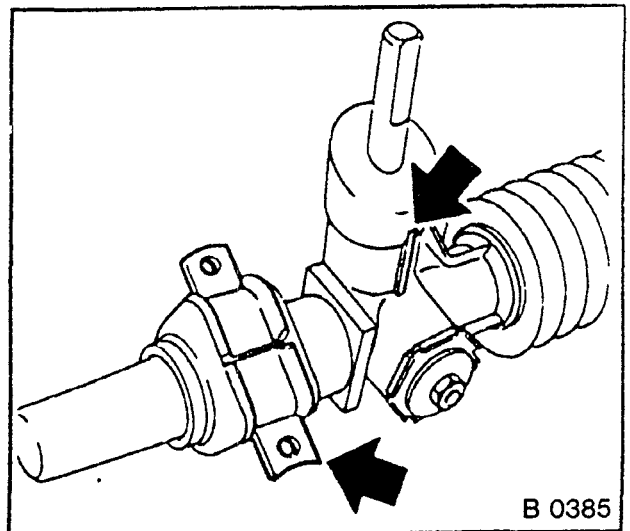


Fig. 52

## Folding Cover on Steering Gear — Replace

### REMOVE, DISCONNECT

Steering gear page 10.

1. Closed rubber bearing ring with retaining bracket from steering gear housing.
2. Both folding covers with housing pipe from steering gear housing.

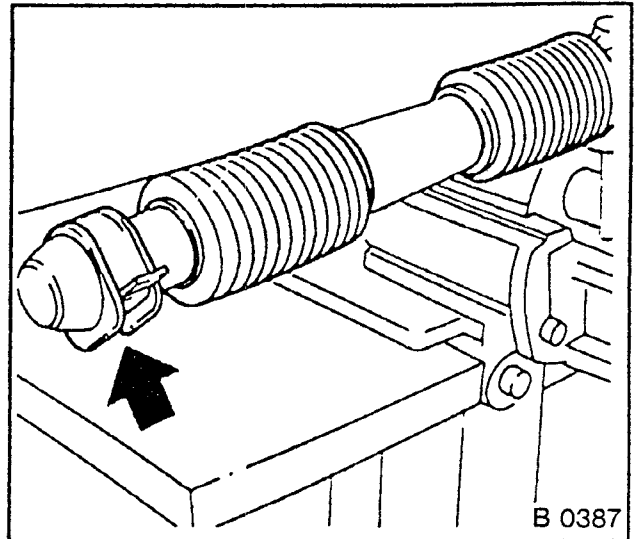


Fig. 53

### INSTALL, CONNECT

- 1 Both folding covers with housing pipe onto steering gear housing.
- 2 Inner and outer folding covers with clamp wires.
- 3 Ends of both wires, in steering gear installation position, point upwards.  
Folding cover must not lie twisted.
4. Closed rubber bearing ring with retaining bracket and bulkhead rubber seal onto steering gear housing.
5. Inner curve of bracket flange points downwards.

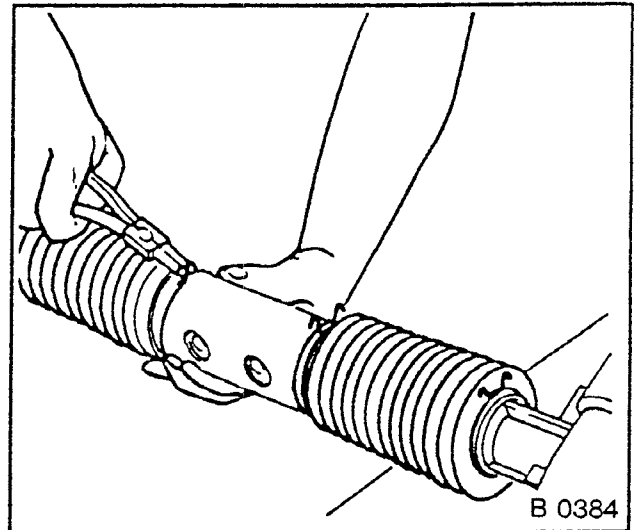


Fig. 54

## Steering Linkage — Tie Rod — Replace

### REMOVE, DISCONNECT

1. Loosen tie rod clamp flange.
2. Tie rod from steering gear.
3. Tie rod from adjusting bolts — measure screw-on depth.

### INSTALL, CONNECT

1. Turn new tie rod (with new damping bushing) onto adjusting bolts.
2. Note left or right version.

### TIGHTEN (TORQUE)

1. Tie rod to steering gear — 95 Nm secure.
2. Tie rod clamp flange — 20 Nm

### ADJUST

Toe-out — See Section E.

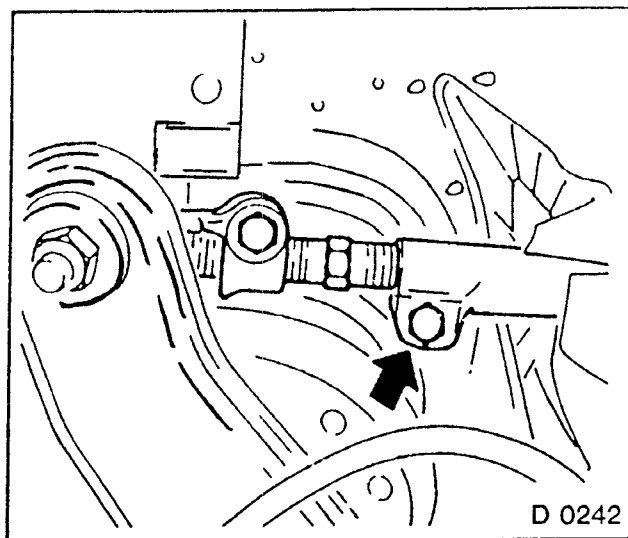


Fig. 55

## Tie Rod End — Replace

### REMOVE, DISCONNECT

1. Loosen clamp flange.
2. Tie rod end from tie rod lever — KM-507-C.
3. Tie rod end from adjusting bolts — measure screw-on depth.

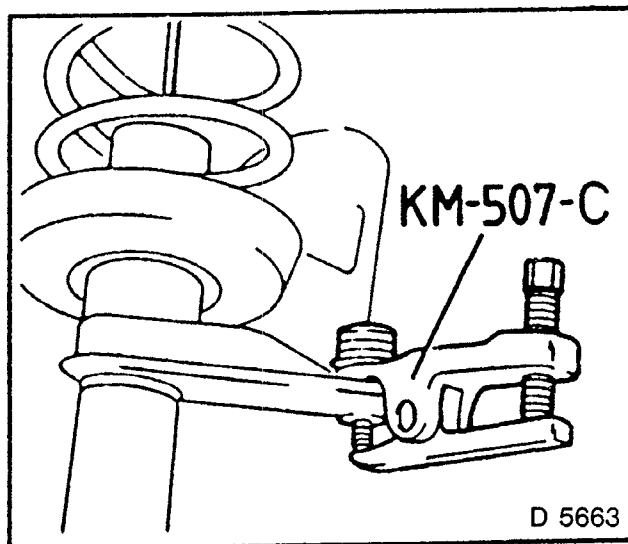


Fig. 56



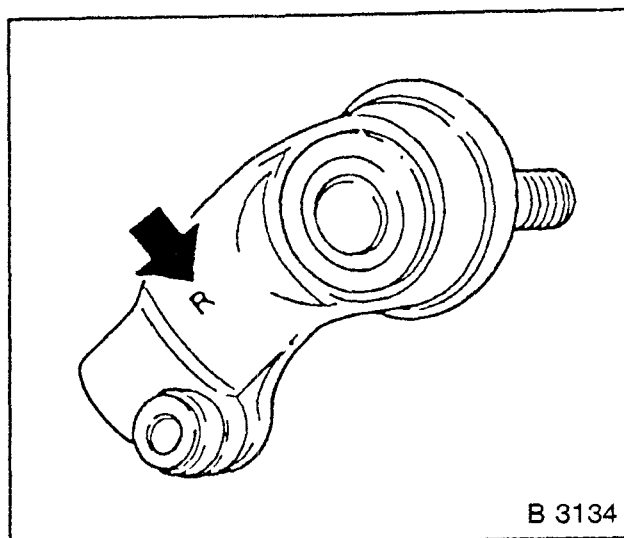
4. Turn new tie rod end onto adjusting bolts.
5. Observe screw-on depth.  
Right side is marked with "R".

### TIGHTEN (TORQUE)

1. Tie rod clamp flange — 20 Nm.
2. Tie rod end to tie end lever — 60 Nm.
3. Use new self-locking nut.

### ADJUST

1. Toe-out — See Section E.



B 3134

Fig. 57

## STEERING WHEEL

### Steering Wheel/Slip Ring — Replace

#### REMOVE, DISCONNECT

1. Cover cap with horn button from steering wheel.
2. Steering wheel from steering shaft — KM-210-A, mark steering shaft installation position.
3. If necessary, place new contact ring in steering wheel hub. Signal return segment of contact ring points in installation position towards the left.

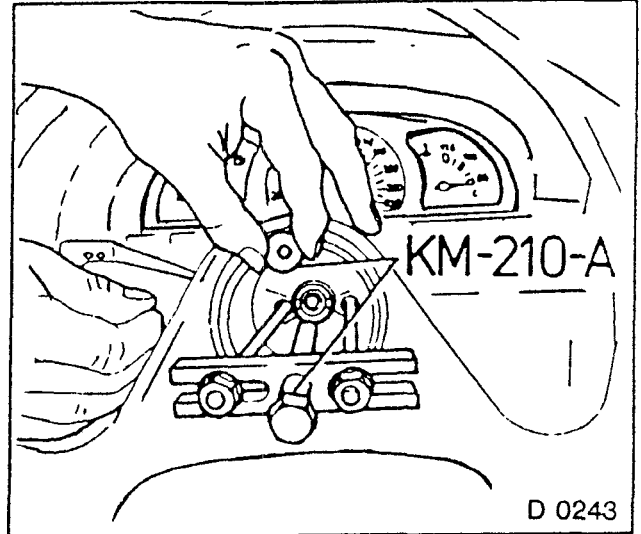


Fig. 58

4. Lubricate contact surface of contact finger on contact plate with commercially available contact agent.

#### TIGHTEN (TORQUE)

1. Steering wheel to steering shaft — 25 Nm and secure.

#### INSPECT

1. Steering straight ahead position.

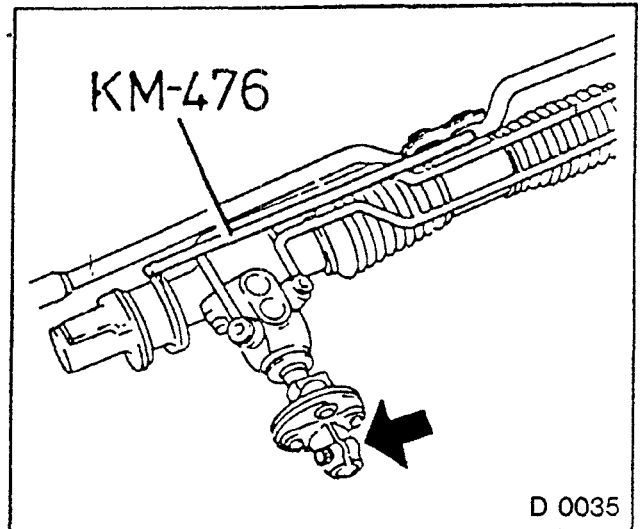


Fig. 59

## STEERING COLUMN

### Steering Shaft Upper Ball Bearing — Replace

#### REMOVE, DISCONNECT

1. Steering wheel from steering shaft — KM-210-A.
2. Two-part signal switch panelling — five bolts.
3. Signal switch and wiper switch from switch housing.
4. Switch housing, lever out housing safety plug — two pieces.
5. Turn switch housing to left and remove from steering column.
6. Ball bearing from switch housing — KM-108.
7. Press both bearing retaining lugs apart.

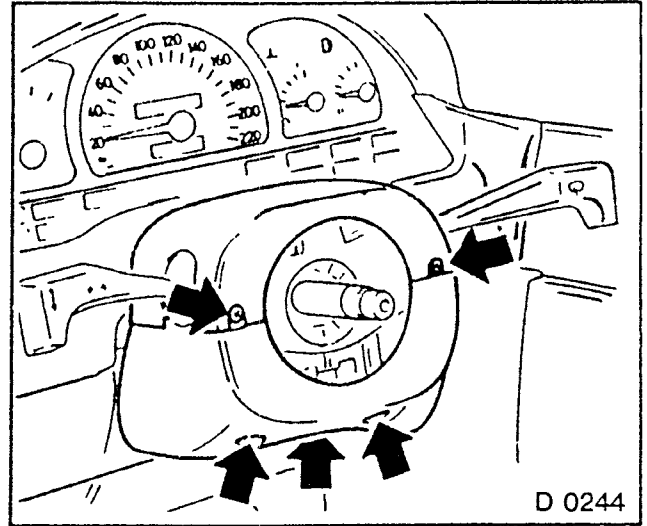


Fig. 60

#### INSTALL, CONNECT

1. New ball bearing — KM-108.
2. Note installation position of bearing and both contact springs.
3. Press down both contact springs.
4. Engage bearing in retaining lugs.
5. Switch housing.
6. Use new safety plug.
7. Signal switch and wiper switch.
8. Two-part signal switch panelling.

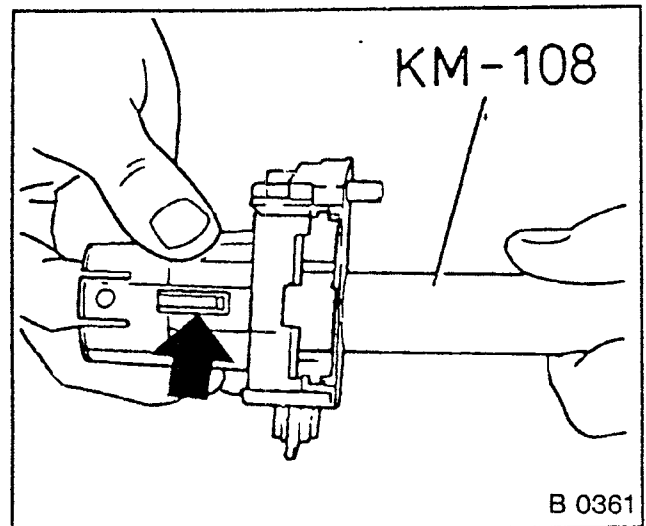


Fig. 61

#### TIGHTEN (TORQUE)

1. Steering wheel to steering shaft — 25 Nm and secure.

#### INSPECT

1. Straight ahead position of steering.

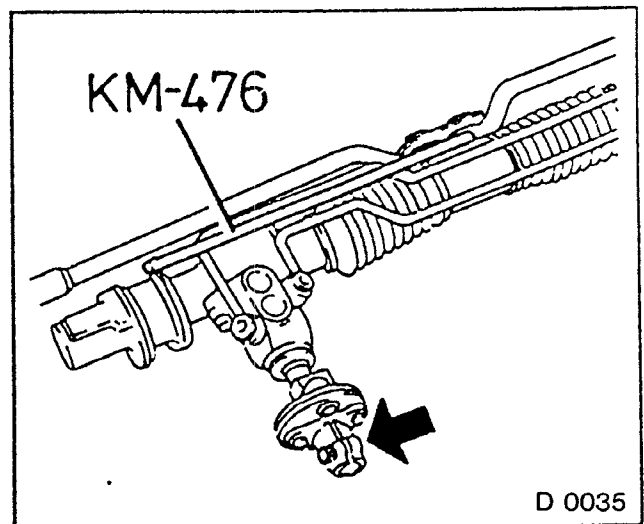


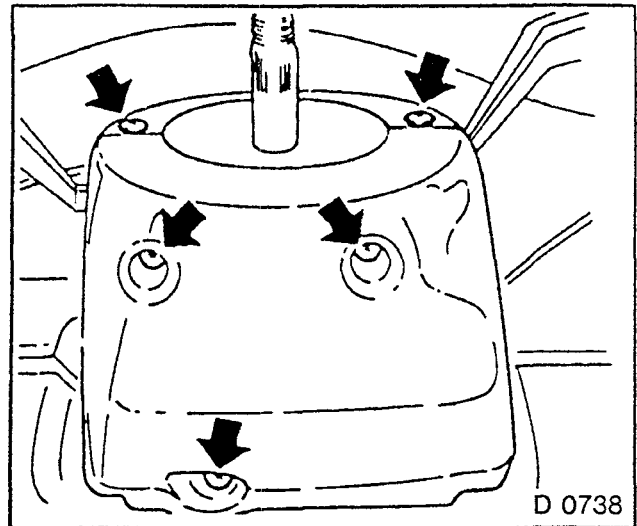
Fig. 62

## Steering Column Assembly — Remove and Install

### REMOVE, DISCONNECT

- 1 Ground cable from battery.
- 2 Footwell panelling — six retaining clamps.
- 3 Upper and lower signal switch panelling.

Fig. 63 — Steering column with steering wheel removed.

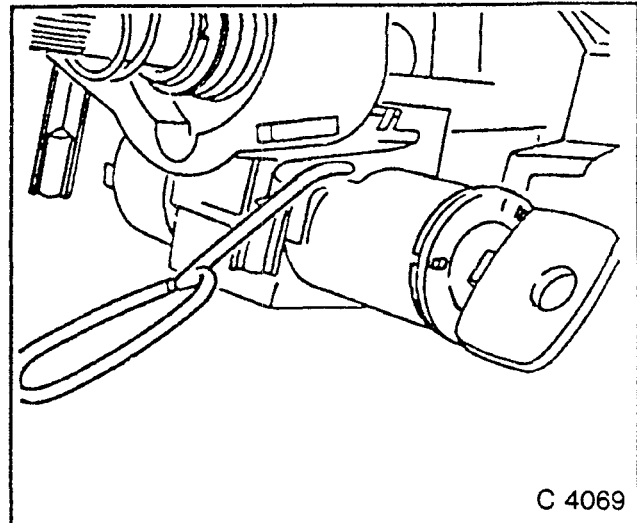


D 0738

Fig. 63

### REMOVE, DISCONNECT

- 1 Lock cylinder
- 2 Press down detent spring in position II with welding rod
- 3 Wiring harness plug for steering and ignition lock from contact part.
- 4 Signal switch and wiper switch.
- 5 Fuse box cover and lower signal switch cover.



C 4069

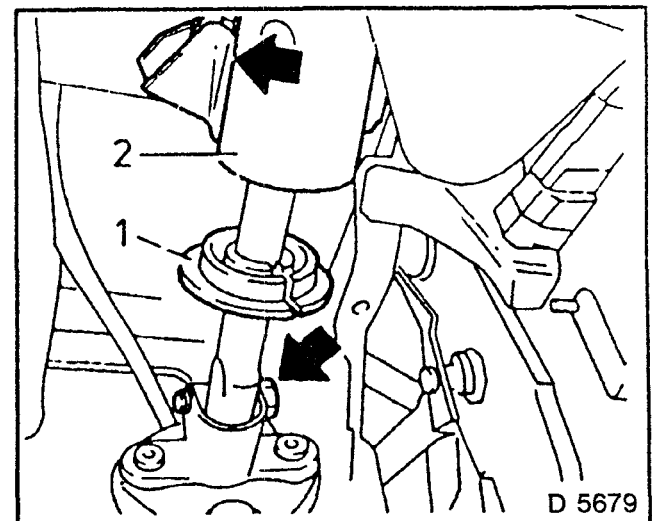
Fig. 64

### REMOVE, DISCONNECT

1. Clamp bolt for steering shaft flange.
  2. Insert loosely seated plastic washer (1) into steering column (2).
  3. Hex bolt for steering column fastening.
- Where height adjustable steering wheel is fitted, place steering wheel in highest position.

### REMOVE, DISCONNECT

1. Shear plates from instrument panel.  
One hex bolt (right), one shear bolt (left).



D 5679

Fig. 65

2. Enlarge installation aperture in marked area by several millimetres (e.g. with round file), so that a centre punch or drill with a flexible shaft can be applied at right angles to the shear bolt.
3. Punch shear bolt centrally. Punch approximately 160 mm long and drill with  $\varnothing 2.5$  mm drill (1) with flexible shaft (2), then drill with a  $\varnothing 4.5$  mm drill.
4. Screw out shear bolt — screwdriver.
5. Steering column assembly from steering shaft flange.

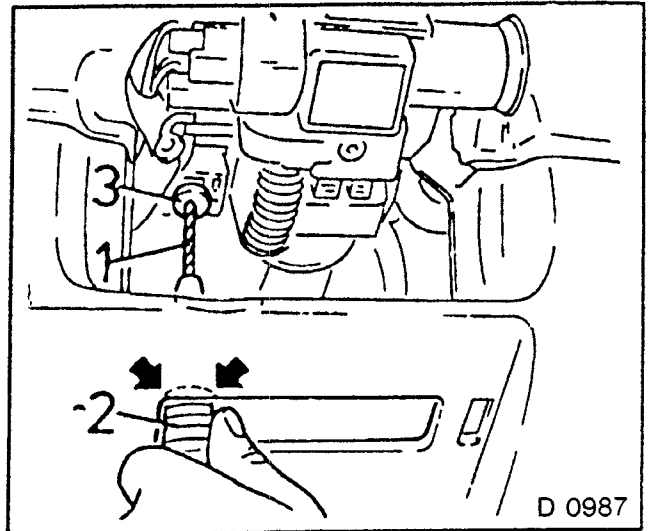


Fig. 66

## INSTALL, CONNECT

1. Steering column assembly.
2. Insert synthetic washer (1) in steering column for centering steering shaft.
3. **Carefully** insert steering shaft in steering shaft flange.
4. Pre-install shear plate, steering column support and steering shaft flange clamp bolt.

Note straight ahead position of steering.

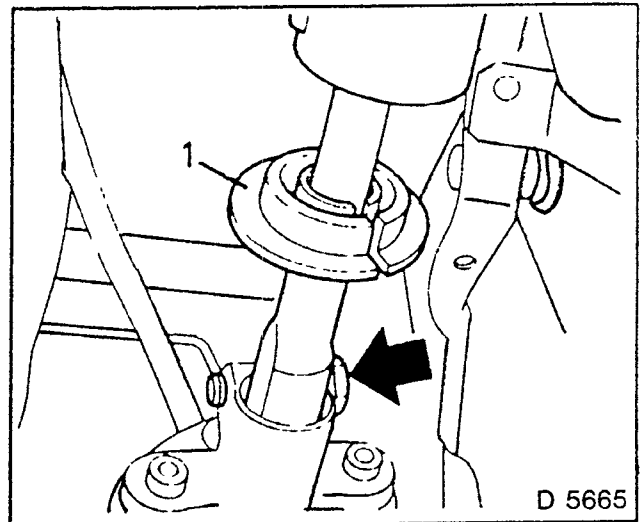


Fig. 67

## TIGHTEN (TORQUE)

1. Steering column with bracket to bulkhead — 22 Nm.
2. Shear plate to instrument panel — 22 Nm.
3. Left side — shear bolt.
4. Clamp bolt, steering shaft to steering coupling — 22 Nm.
5. Press synthetic washer (1) out of steering column.

## INSTALL, CONNECT

1. Wiring harness plug for steering and ignition lock into contact part.
2. Signal switch and wiper switch in switch housing.

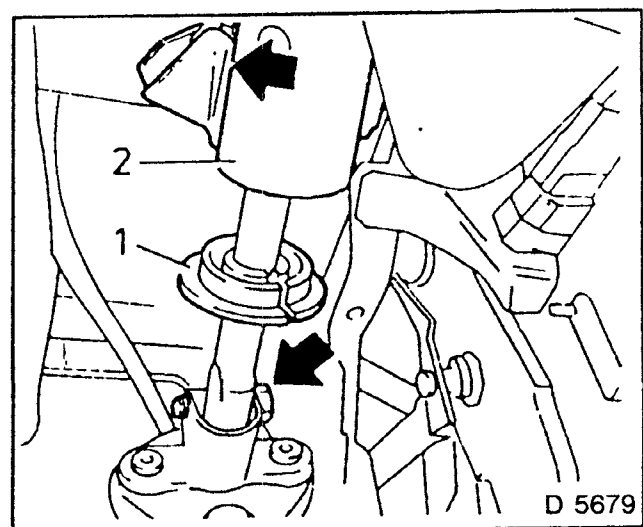


Fig. 68

3. Two-part signal switch panelling.
4. Rubber cover for steering and ignition lock.
5. Lock cylinder.
6. Footwell panelling.
7. Fuse box cover.
8. Lower steering column jacket.
9. Ground cable to battery.

## INSPECT

1. Straight ahead position of steering

## Steering Column Assembly — Disassemble and Assemble

Steering column with fixed steering wheel.  
Steering column assembly installed.

### REMOVE, DISCONNECT

1. Ground cable from battery.
2. Cover cap with horn button from steering wheel.
3. Steering wheel nut from steering shaft.
4. Steering wheel — KM-210-A, mark installation position.
5. Puller hook claws point outwards.
6. Two-part signal switch panelling, lock cylinder.
7. Press down detent spring in position II with welding rod.
8. Signal switch and wiper switch.
9. Depress both locking lugs (top and bottom).
10. Switch housing — lever out housing safety plug.
11. Ball bearing from switch housing — KM-108.
12. Press both bearing retaining lugs apart.

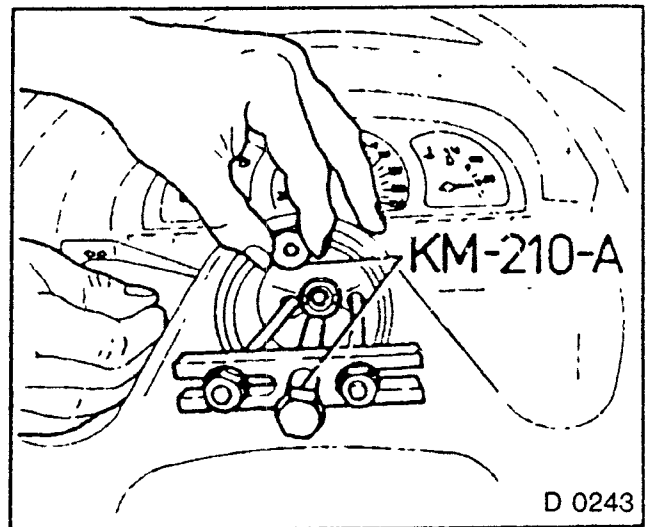


Fig. 69

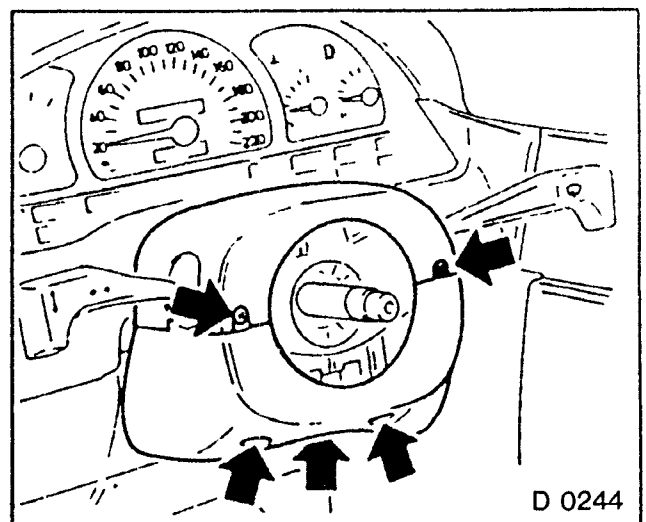


Fig. 70

**INSTALL, CONNECT**

1. New ball bearing in switch housing — KM-108
2. Note thrust washer (1) in front of ball bearing.
3. Note installation position of bearing and both contact springs (2).
4. Press down both contact springs.

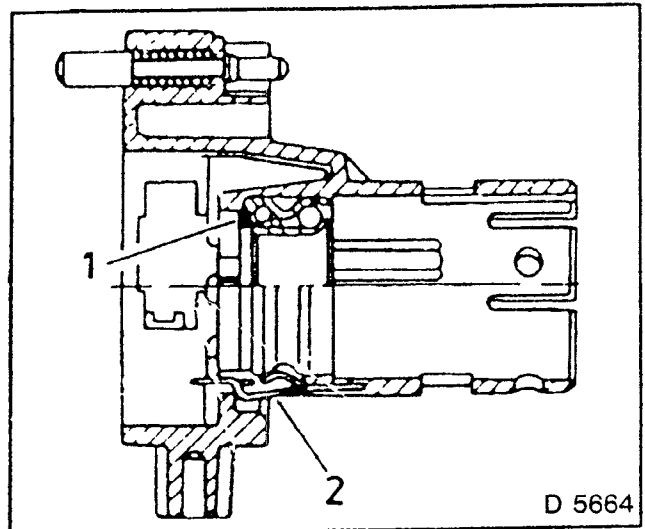


Fig. 71

**REMOVE, DISCONNECT**

1. Contact part. (Fig. 72 shows steering wheel with height adjustment).
2. Wiring harness plug from contact part, both threaded pins.
3. Steering shaft from steering shaft flange.
4. Insert the loosely seated synthetic washer into steering column.
5. Steering shaft from steering column.

**CAUTION:**

**DO NOT KNOCK OR BUMP THE SHAFT.**

**ASSEMBLE**

1. Steering shaft onto disc joint.
2. Contact part onto steering and ignition lock housing.
3. Switch housing onto steering column — new safety plug.
4. Signal switch and wiper switch — with inserted wiring harness plugs — onto housing.
5. Upper and lower signal switch panelling.
6. Lock cylinder for steering and ignition lock.
7. Lock cylinder and contact part same switch position.
8. Rubber cover onto housing for steering and ignition lock.
9. Disc and pressure spring onto steering shaft ball bearing.

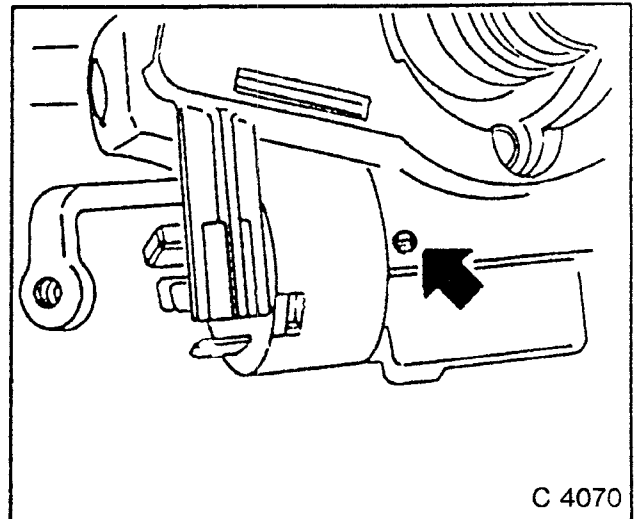


Fig. 72

**TIGHTEN (TORQUE)**

1. Steering wheel to steering shaft — 25 Nm and secure.
2. Installation position — press in steering shaft until it lies on steering shaft ball bearing.
3. Clamp bolt and steering shaft to steering coupling — 22 Nm.
4. Press synthetic washer, previously inserted into steering column (1), out of column (sits loosely on steering shaft).
5. Ground cable to battery.

**INSPECT**

1. Straight ahead position of steering.

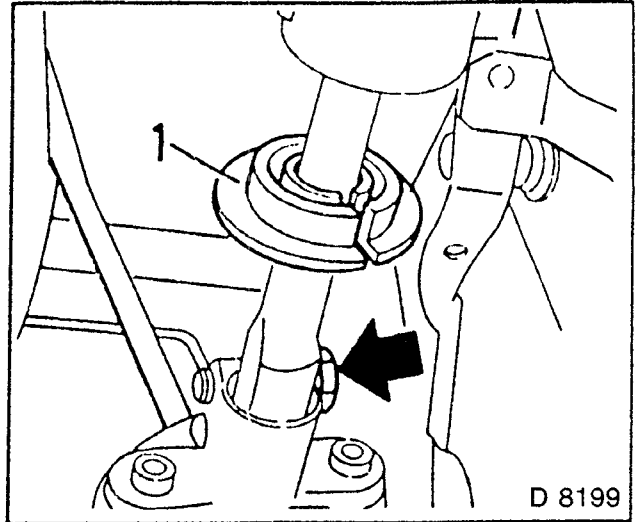


Fig. 73

## Steering Column Assembly — Disassemble and Assemble

Steering column with height adjustable steering wheel

Steering column assembly installed

**REMOVE, DISCONNECT**

1. Ground cable from battery.
2. Cover cap with horn button from steering wheel.
3. Steering wheel from shaft — KM-210-A. Mark installation position.
4. Puller hook claws point outwards.
5. Hand adjustment lever for steering wheel height adjustment.
6. Signal switch panelling — five bolts.
7. Lock cylinder — press down detent spring in position II.
8. Contact part — remove wiring harness plug, unscrew set screws.
9. Switch housing — two bolts, push in direction of steering wheel.

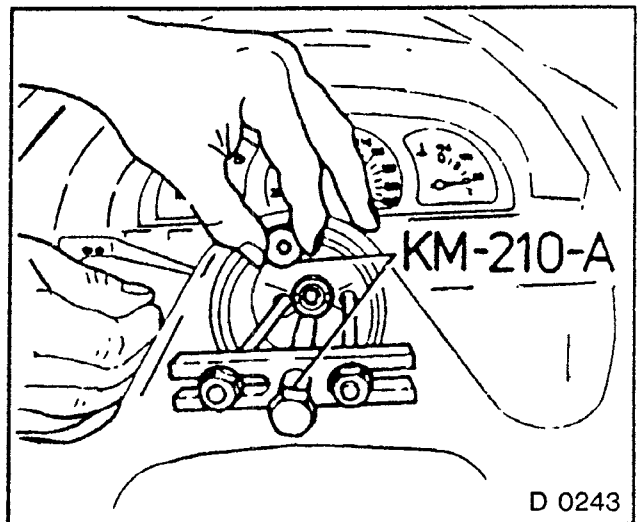


Fig. 74

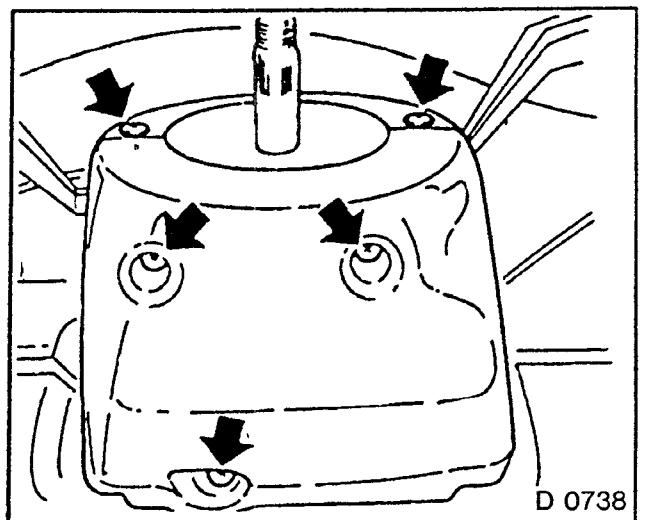


Fig. 75



**REMOVE, DISCONNECT**

- 1 Signal switch and wiper switch — with switch lever.
2. Depress both locking lugs (top and bottom).
3. Upper and lower steering column jacket — six bolts

**REMOVE, DISCONNECT****STEERING COLUMN**

- 1 Depresser ring for pressure spring from steering shaft.
2. Press depresser ring with Adapter KM-538 in conjunction with KM-J-23653-A downwards.
3. Remove from retaining ring with sharp-nose pliers and screwdriver.

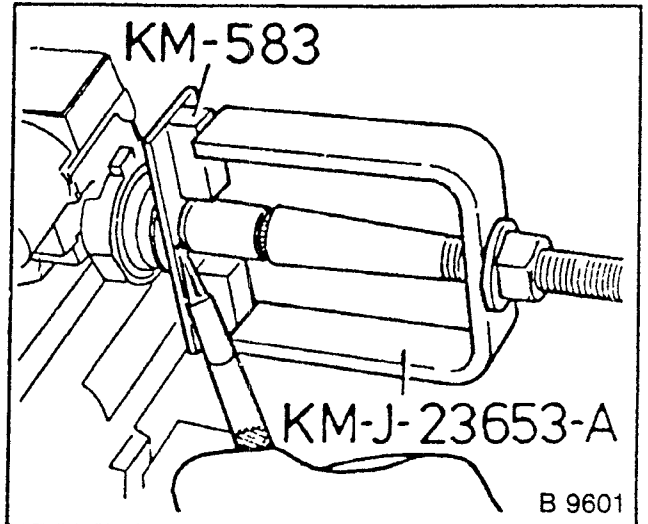


Fig. 76

**DISASSEMBLE****STEERING COLUMN**

- 1 Pressure spring for bearing.
2. Pressure ring
3. Bearing ring for outer bearing from steering shaft.
  - 1 Retaining ring
  - 2 Depressor ring
  - 3 Pressure spring for bearing
  - 4 Pressure ring
  - 5 Bearing ring for outer bearing

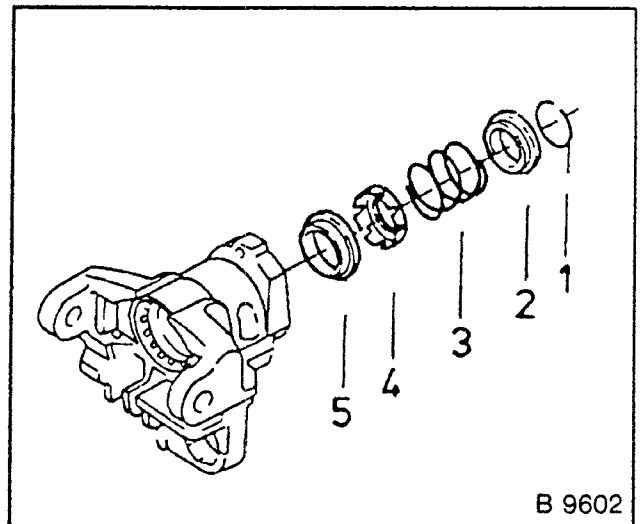


Fig. 77

**REMOVE, DISCONNECT**

1. Pressure spring for height adjustment — KM-584.

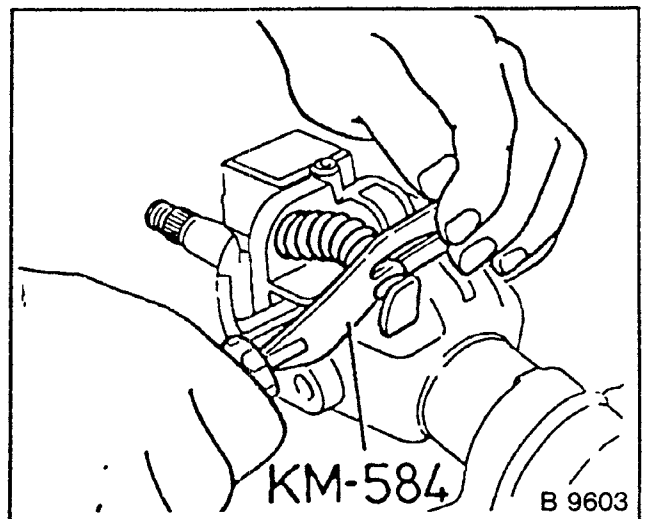


Fig. 78

**DISASSEMBLE**

1. Both fulcrum bearing pins from bearing housing — KM-585.
2. Remove bearing housing.

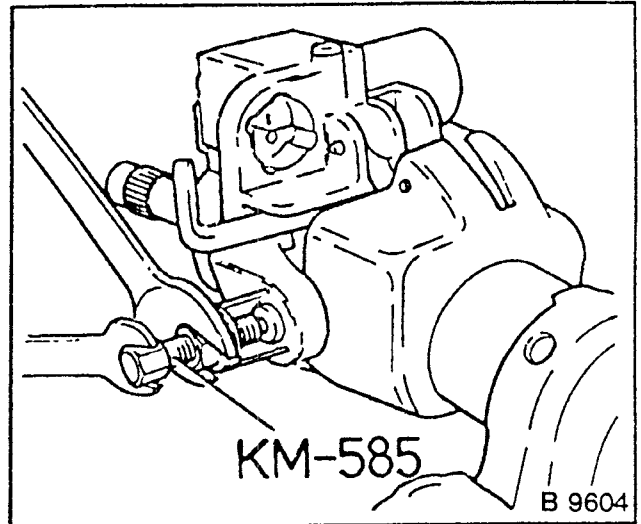


Fig. 79

3. Housing for steering and ignition lock from bearing housing — ONLY when replacing bearing housing or ignition lock housing.
4. Drill of both bolt heads — drill  $\varnothing$  6.5 mm.

**ASSEMBLE**

1. Fasten new housing with two retaining screws.
2. Install new bolts (not microencapsulated) with Sealing Compound. LOCKTITE 242.
3. Cut threaded holes M 6 free. Housing is only delivered in assembly with ball bearings.

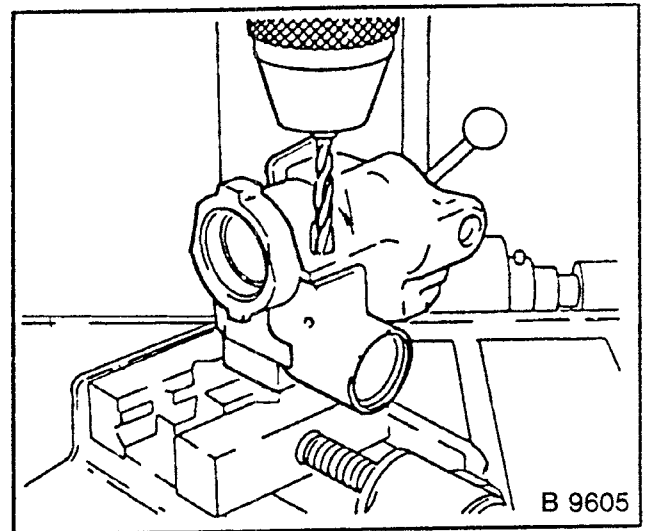


Fig. 80

**DISASSEMBLE**

1. Adjust lever and both detent levers from bearing housing.
2. Steering shaft universal joint.
3. If necessary, replace parts and reassemble.
4. Wire springs must lie in recesses of each half of joint.
5. Bearing ring for inner bearing from upper steering shaft part — ONLY when replacing bearing housing with both ball bearings.
6. Press off ring carefully with hammer and chisel.

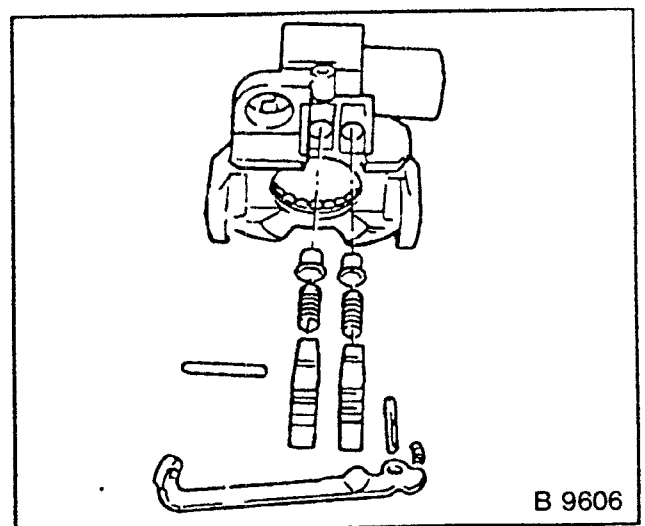


Fig. 81

**ASSEMBLE****Steering column.**

1. New bearing ring onto upper steering shaft part — KM-311.
2. Adjust lever and both detent levers to bearing housing.
3. Both fulcrum bearing pins in bearing housing.
4. Pressure spring for height adjustment — KM-584.
5. Bearing ring for outer bearing onto steering shaft.
6. Pressure ring, pressure spring for bearing.
7. Depressor ring for pressure spring onto steering shaft.

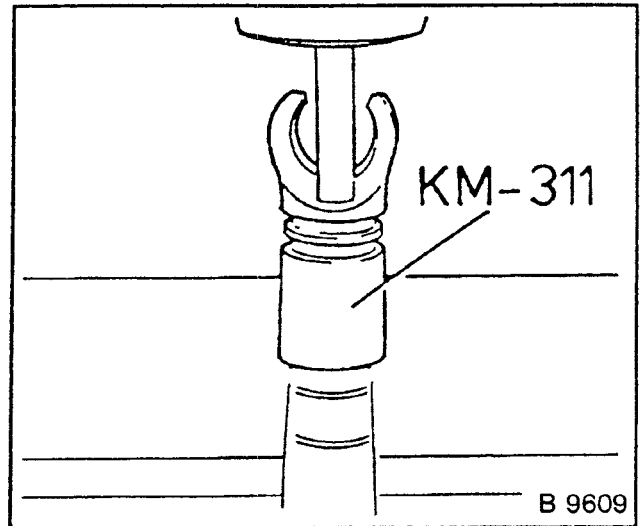


Fig. 82

**NOTE:****Fastening of fulcrum bearing pins onto bearing housing.**

In each case, bottom out in three places.

**INSPECT**

1. Gap between housing and both stop buffers in top steering wheel lock position with feeler gauge.
2. Exact fit, without moving the steering wheel further
3. If necessary, adjust gap with left and/or right stop buffer.

**INSTALL, CONNECT**

1. Steering column assembly

**INSPECT**

1. Straight ahead position.

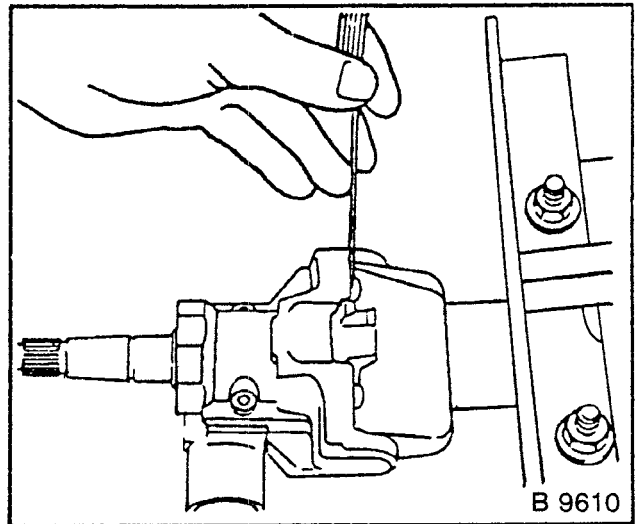


Fig. 83

## Disc Joint — Replace

Steering gear in straight ahead position.

### REMOVE, DISCONNECT

1. Clamp bolts for steering shaft and steering pinion from disc joint.
2. Steering gear from bulkhead.
3. Push disc joint onto steering shaft.
4. Disc joint.

### TIGHTEN (TORQUE)

- 1 Steering gear to bulkhead — 22 Nm.
- 2 Steering gear must be in straight ahead position.
- 3 Clamp bolt, steering pinion to steering coupling — 22 Nm.
4. Clamp bolt, steering shaft to steering coupling — 22 Nm.
5. Pull steering shaft until it lies on steering shaft ball bearing.

### INSPECT

1. Straight ahead position.

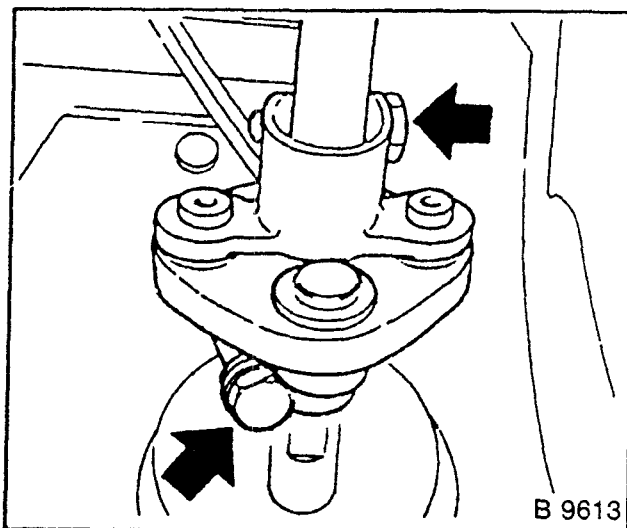


Fig. 84

## Upper Steering Shaft — Replace

"Steering Column Assembly, Disassemble and Assemble", page 33.

## Steering Column — Replace

### REMOVE, DISCONNECT

1. Steering column assembly.
2. Steering column in vice.

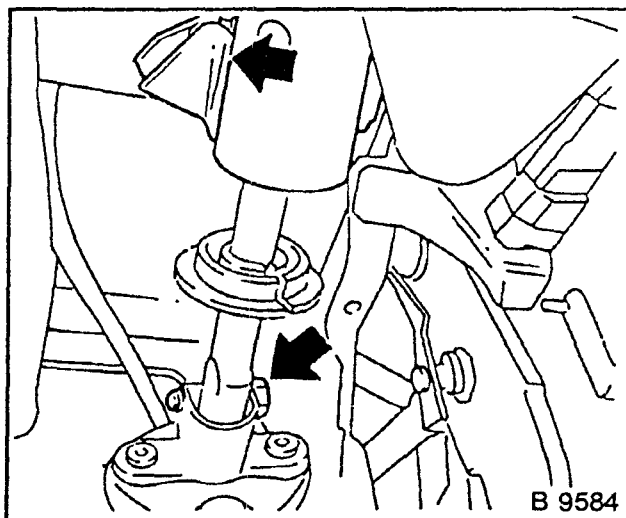


Fig. 85

**DISASSEMBLE**

1. Housing for steering and ignition lock from steering column.
2. Drill off screw head — drill  $\varnothing$  8.5 mm
3. Replace steering column.

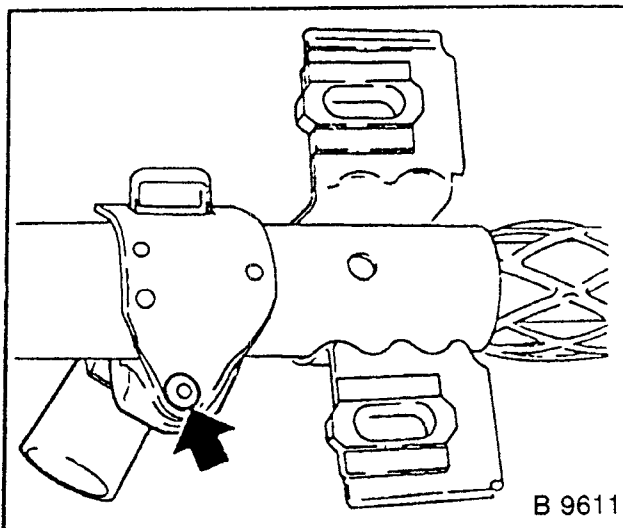


Fig. 86

**ASSEMBLE**

1. Housing for steering and ignition lock onto steering column.
2. Insert new bolt (not microencapsulated) with Sealing Compound. LOCKTITE 242.

**INSTALL, CONNECT**

1. Steering column.
2. Check straight ahead position.

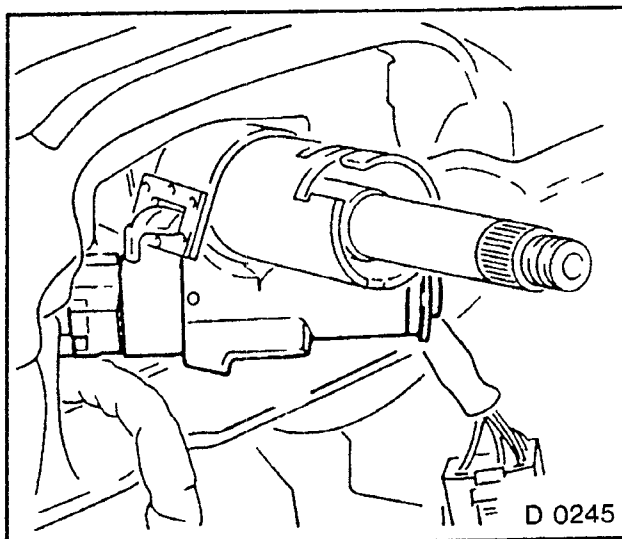


Fig. 87

## POWER STEERING

### General

#### Design:

Power steering gear rack with "rotary sliding valve".

Adjustment of steering is not necessary.

An overhaul or disassembly of power steering gears is not envisaged for dealer workshops.

Main components of rotary sliding valve:

- Rotary slider with needle bearing (1) surrounded with six control grooves.
- One-part control bushing (2) with six control grooves internally arranged, which correspond to those of the rotary slider.
- Torsion rod (3) positioned centrally on valve.

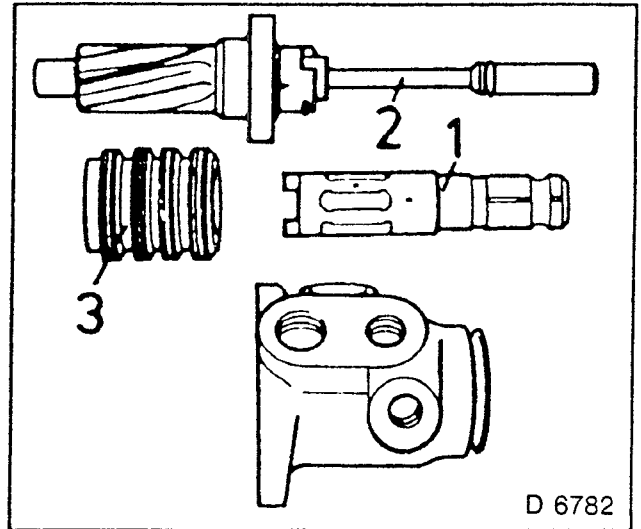


Fig. 88

### Hydraulic System, Top up

Top up fluid reservoir to marking "MAX" (1) and start engine.

Top up sinking fluid level immediately to marking "MIN" (2) and allow engine to run for approximately fifteen seconds.

Turn steering to stop and hold in this position for approximately ten seconds.

Carry out this operation to right and left twice.

Check fluid level again:

Fluid at operating temperature (approximately 80°C/176°F) — up to marking "MAX" (1)

Fluid cold (approximately 20°C/68°F) — up to marking "MIN" (2)

Check hydraulic system for leaks.

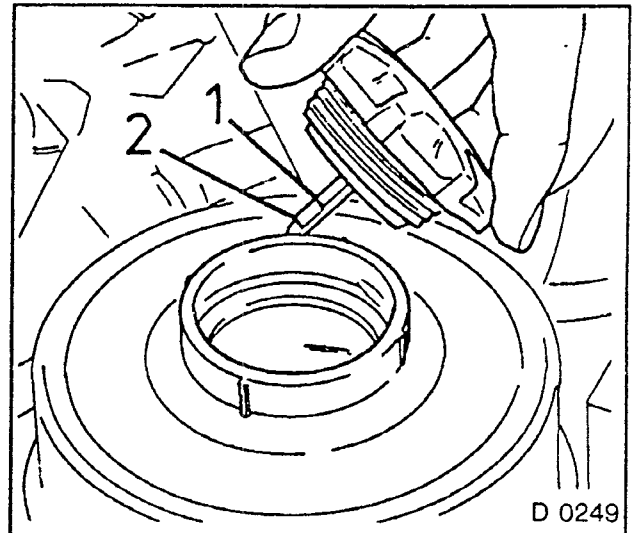


Fig. 89

## V-belt for Hydraulic Pump — Replace

Vehicles without AC

### REMOVE, DISCONNECT

1. V-belt.
2. Loosen bolts (1), (2), (3).
3. Loosen tensioning screw nuts (Fig 91).

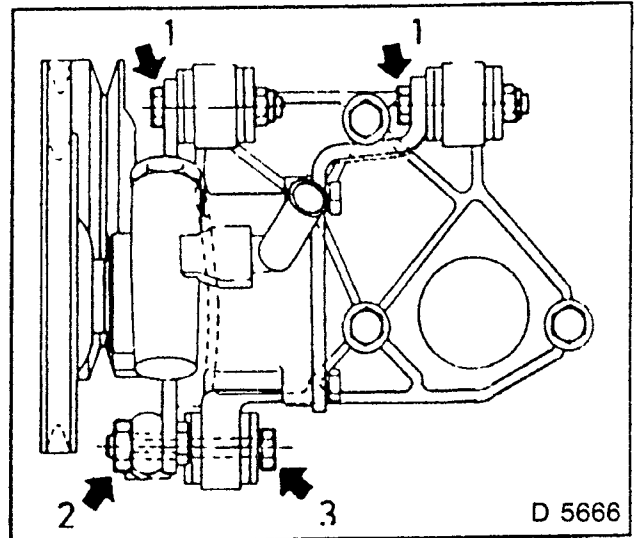


Fig. 90

### INSTALL, CONNECT

1. New V-belt.
2. Adjust V-belt tension — KM-128-A, checking value: see Technical Data (page 56).

### TIGHTEN (TORQUE)

1. Bolt (1) — 25 Nm.
2. Bolt (2) — 40 Nm.
3. Bolt (3) — 25 Nm.

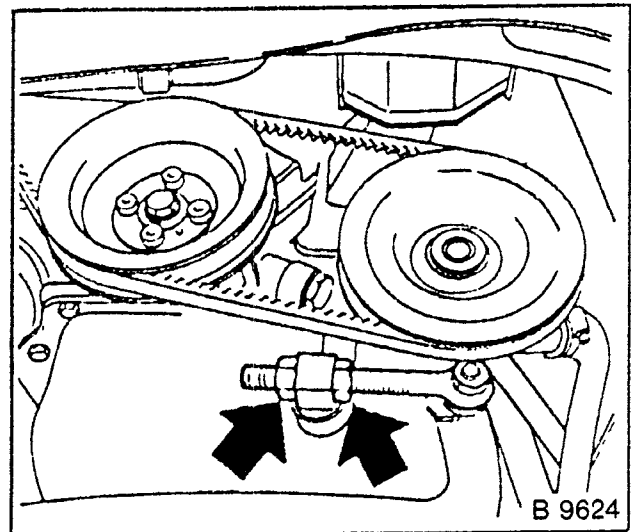


Fig. 91

## V-belt for Hydraulic Pump — Replace

Vehicles with AC

### REMOVE, DISCONNECT

1. V-belt for air conditioning compressor.
2. Loosen locking screws at the front and rear clamping bracket.
3. Loosen fastening bolt (long) on upper compressor outrigger.
4. Loosen lock nut of tensioning screw.
5. Push compressor to engine block.

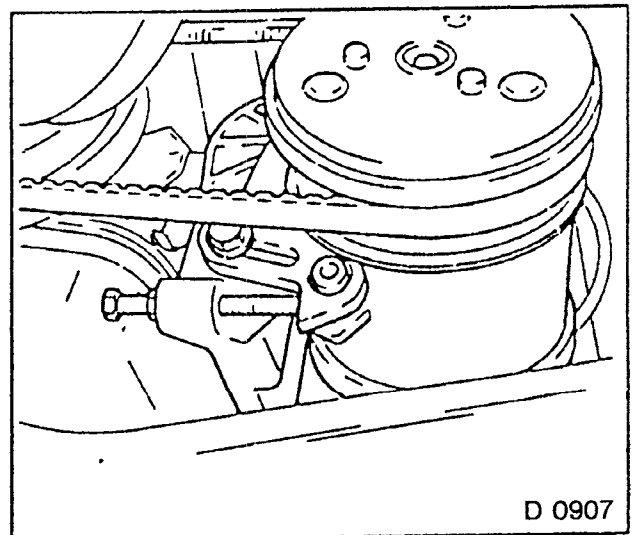


Fig. 92

6. V-belt for hydraulic pump
7. Loosen fastening bolt (long) at retainer
8. Loosen lock nuts and adjustment nuts.
9. Release tension on V-belt.
10. Replace V-belt.

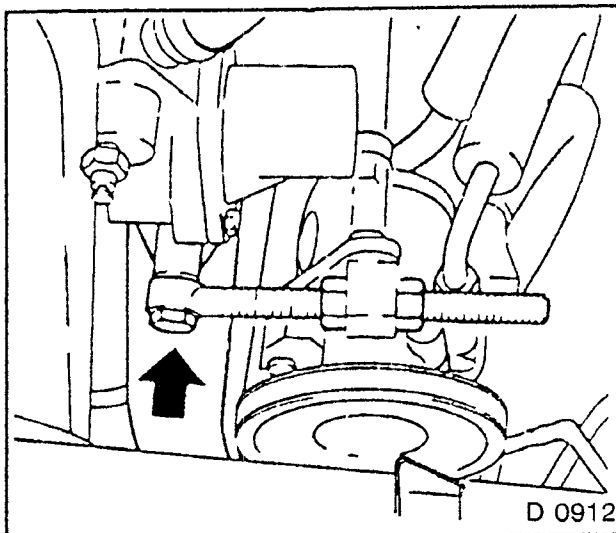


Fig. 93

## ADJUST

1. V-belt tension — KM-128-A, test values: Technical Data page 56.

## TIGHTEN (TORQUE)

1. Lock nut to tensioner of hydraulic pump — 40 Nm.
2. Fastening bolt (long) to bracket — 25 Nm.

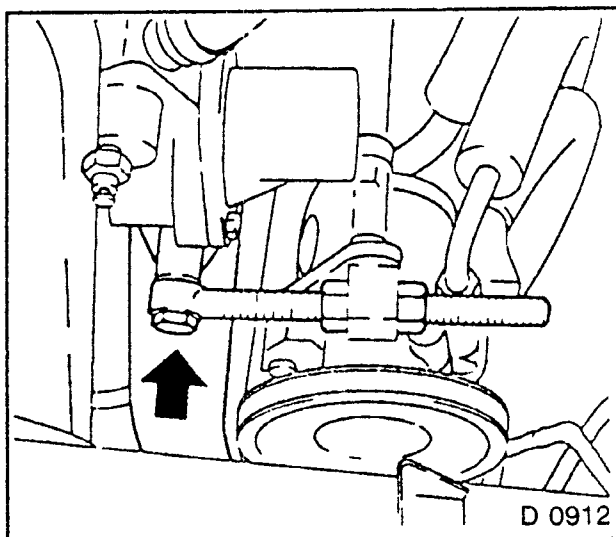


Fig. 94

## INSTALL, CONNECT

1. V-belt for air conditioning compressor.

## ADJUST

1. V-belt tension — KM-128-A, test values: Technical Data page 56.

## TIGHTEN (TORQUE)

1. Lock nut to lower tensioner — 25 Nm.
2. Lock bolts to front or rear clamping brackets — 25 Nm.
3. Fastening bolts (long) to outrigger — 25 Nm.

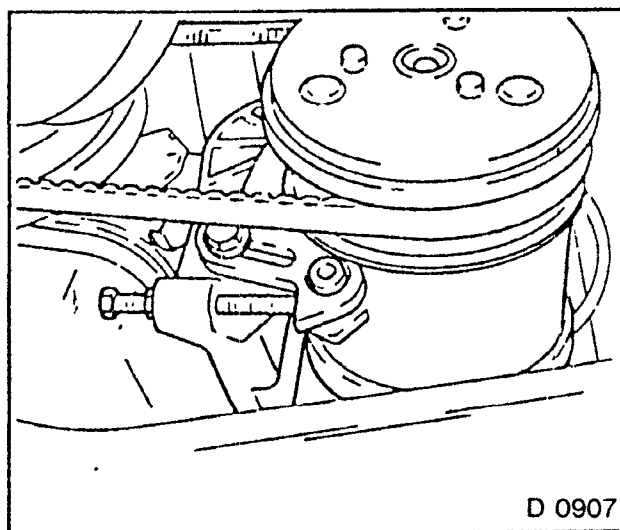


Fig. 95



## Ribbed V-belt for Hydraulic Pump — Replace

### REMOVE, DISCONNECT

1. Air intake hose — if present.
2. Loosen clamping bracket.
3. Lower alternator fastening.
4. Removed ribbed V-belt from hydraulic pump and alternator.
5. Replace V-belt.

### ADJUST

1. Ribbed V-belt tension — KM-612 and torque wrench.  
Test values: Technical Data, page 56.

### TIGHTEN (TORQUE)

1. Clamping bracket to alternator — 25 Nm.
2. Lower alternator fastening — M8: 25 Nm.
3. Lower alternator fastening — M10: 35 Nm.
4. Connect air intake hose — if present.

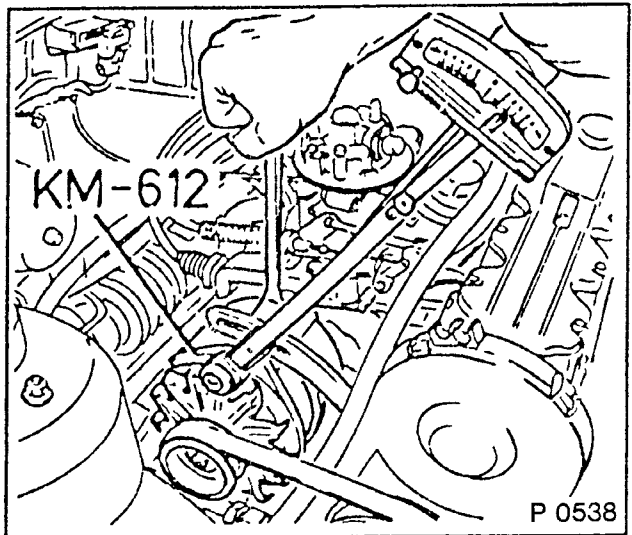


Fig. 96

## Fluid Reservoir — Remove and Install

### REMOVE, DISCONNECT

1. Bracket clamp bolt.
2. Both hose connections — fluid escapes.

### INSTALL, CONNECT

1. Both hose connections.
2. Clamp bolt.
3. Top up and bleed hydraulic system.

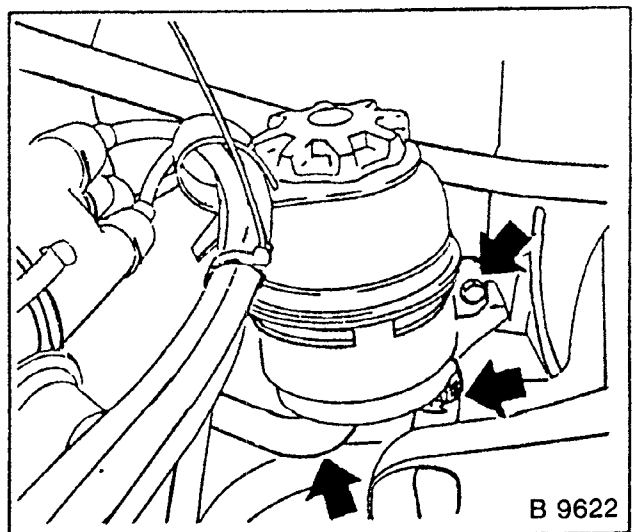


Fig. 97

## Hydraulic Lines — Replace

1 = Pressure line

2 = Expandable hose

3 = Suction hose

4 = Connection hose

5 = Return pipe

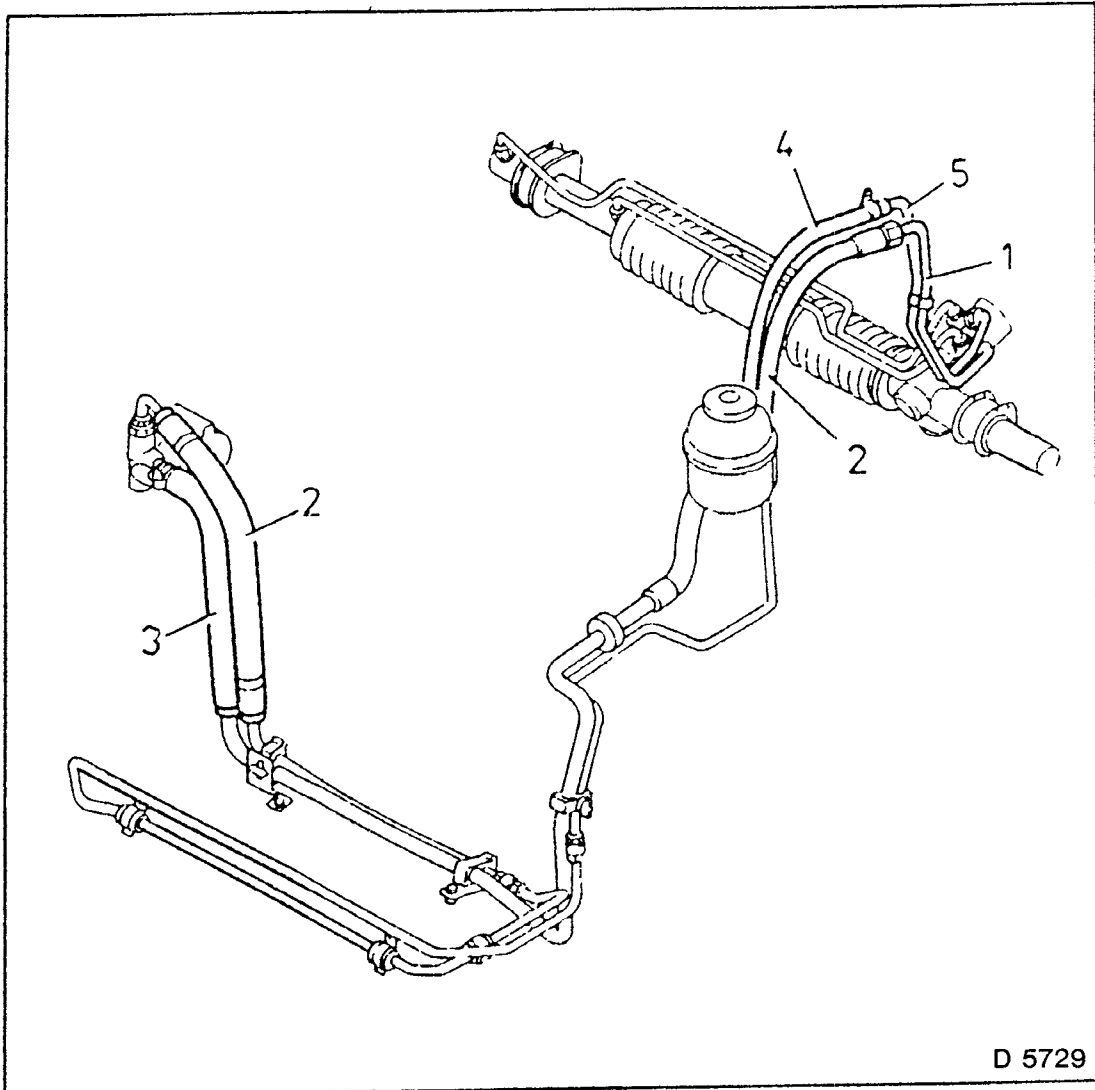


Fig. 98 — Hydraulic lines for power steering

**NOTE:**

1. Fluid escapes when lines and hoses are removed — place collecting pan underneath.
2. When installing
  - 1) ensure that routing is not kinked or twisted.
  - 2) avoid places which could chafe or make contact with hot and rotating components.
3. Replace plastic hose clamps, gaskets, etc — Parts and Accessories Catalogue.
4. After installation, top up hydraulic system.
5. Check for leaks with engine running and actuated steering.

**REPLACE PRESSURE LINE:****REMOVE, DISCONNECT**

- 1 Special bolt from steering gear.
- 2 Union nut from expandable hose.
- 4 Pressure line from fastening elements.

**TIGHTEN (TORQUE)**

1. Pressure line union nut to expandable hose — 28 Nm.
2. Pressure line special bolt to steering — 28 Nm (Saginaw).
3. Insert pressure line in fastening element.

**REPLACE EXPANDABLE HOSE:****REMOVE, DISCONNECT**

1. Expandable hose union nuts from pressure line or hydraulic pump.
2. Expandable hose from fastening element:
  - a) front frame side member (two pieces),
  - b) radiator side member (three pieces).

**TIGHTEN (TORQUE)**

- 1 Expandable hose union nut to hydraulic pump or pressure line — 28 Nm.
- 2 Bolted fastening elements to radiator side member — 7 Nm.

**Coolant Loop — Replace****REMOVE, DISCONNECT**

- 1 Front panelling
  - To side member — Two nuts
  - To side bracket — Four bolts
  - Heavy-duty version "Front Member (Radiator Crossmember)" — Four body-bound rivets.

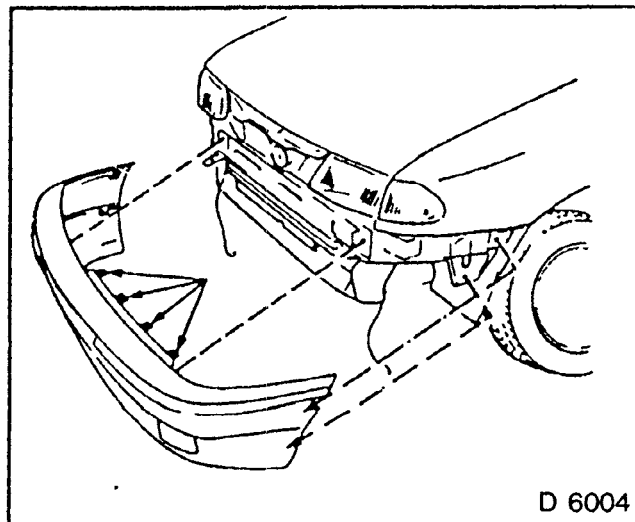


Fig. 99

**REPLACE RETURN PIPE:****REMOVE, DISCONNECT**

1. Special bolt from steering gear.
2. Hose clamp from connection hose.

**TIGHTEN (TORQUE)**

1. Hose clamp of connection hose to return pipe — tighten so that it is oil-tight.
2. Return pipe special bolt to steering gear — 28 Nm (Saginaw).

**REPLACE CONNECTION HOSE:****REMOVE, DISCONNECT**

1. Hose clamps from return pipe or suction hose.
2. Connection hose from fastening element.

**INSTALL, CONNECT**

1. Connection hose — hose clamps to return pipe or suction hose.
2. Connection hose to fastening element.

**REPLACE SUCTION HOSE:****REMOVE, DISCONNECT**

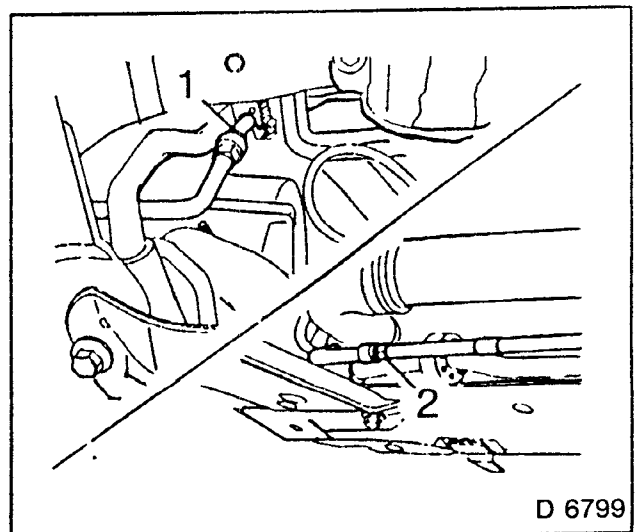
1. Hose clamps from compressor or fluid reservoir
2. Suction hose from fastening elements:
  - a) front frame side member (two pieces),
  - b) radiator side member (three pieces).

**INSTALL, CONNECT**

1. Suction hose — hose clamps to compressor or fluid reservoir — tighten so that it is oil-tight.
2. Bolted fastening elements to radiator side member — 7 Nm.

**REMOVE, DISCONNECT****FRONT PANELLING:**

1. Union nut (1) expandable hose to steering gear.
2. Union nut (2), expandable hose to hydraulic pump.



D 6799

Fig. 100

**REMOVE, DISCONNECT**

1. Coolant loop from brackets (arrows).
2. Remove coolant loop towards front.

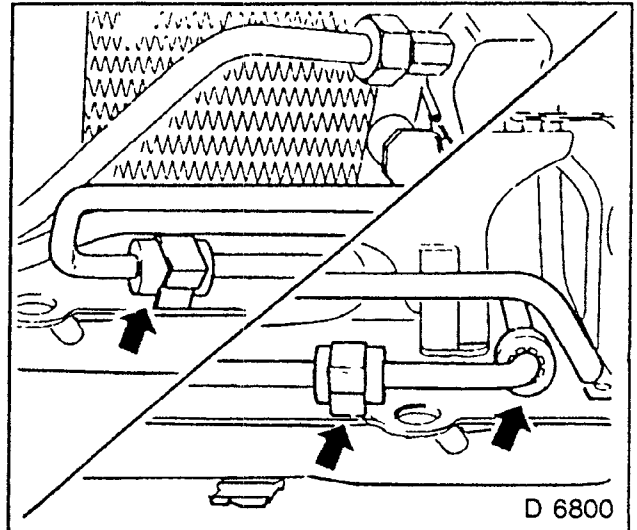


Fig. 101

**INSTALL, CONNECT**

1. Insert coolant loop from front in front body.
2. Coolant loop in bracket.

**TIGHTEN (TORQUE)**

1. Union nut (1), expandable hose to steering gear — 28 Nm
2. Union nut (2), expandable hose to hydraulic pump — 28 Nm.

**INSTALL, CONNECT**

1. Front panelling

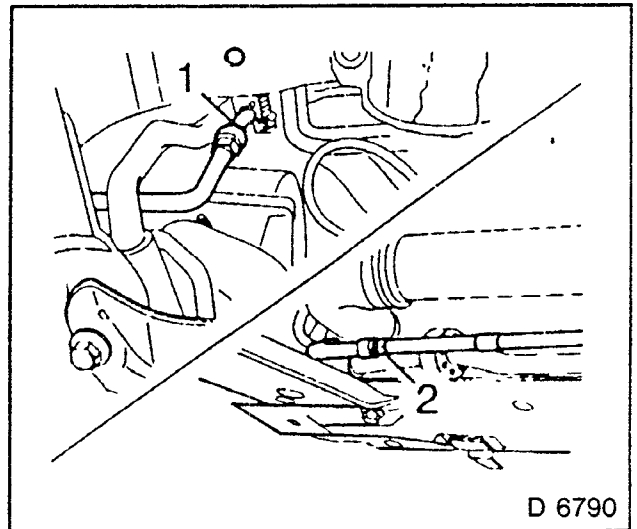


Fig. 102

**Hydraulic Pump — Remove and Install**

**ENGINES WITH DISPLACEMENT UP TO 1.6 LTR.**

**REMOVE, DISCONNECT**

1. Air cleaner box.
2. Ribbed V-belt.
3. Hydraulic pump pulley.

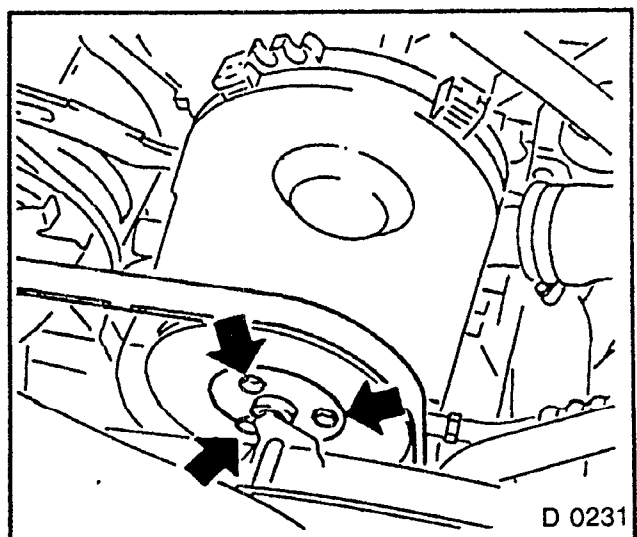


Fig. 103

**REMOVE, DISCONNECT**

1. Upper toothed belt cover  
See operation "Toothed Belt, Replace" in Section J.
2. Hydraulic pump from cylinder block.
3. Remove hydraulic pump — in direction of alternator
4. Pressure and return hose. Fluid escapes.
5. Close openings.

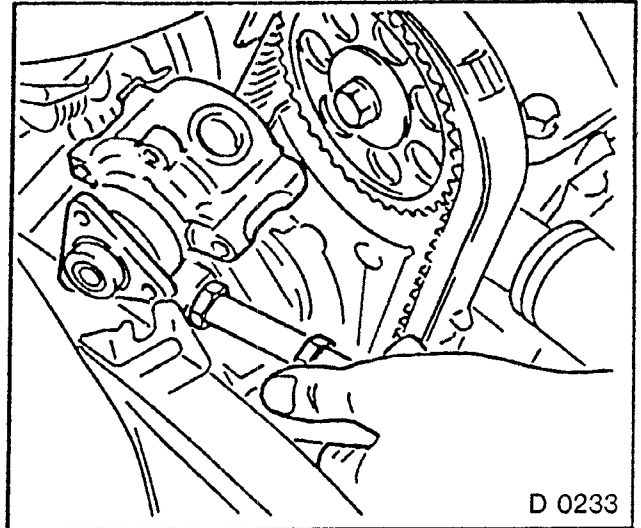


Fig. 104

**INSTALL, CONNECT**

1. Pre-install hydraulic pump onto cylinder block.
2. Upper toothed belt cover.

**TIGHTEN (TORQUE)**

1. Hydraulic pump to cylinder block — 30 Nm.
2. Pulley to hydraulic pump — 25 Nm.

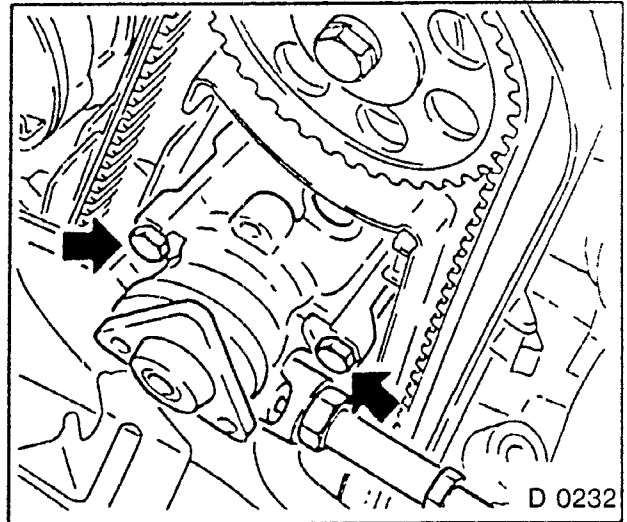


Fig. 105

**INSTALL, CONNECT**

1. Ribbed V-belt — adjust ribbed V-belt tension. See Section J.
2. Pressure and return lines to hydraulic pump
3. Air cleaner box.
4. Top up and bleed hydraulic system.

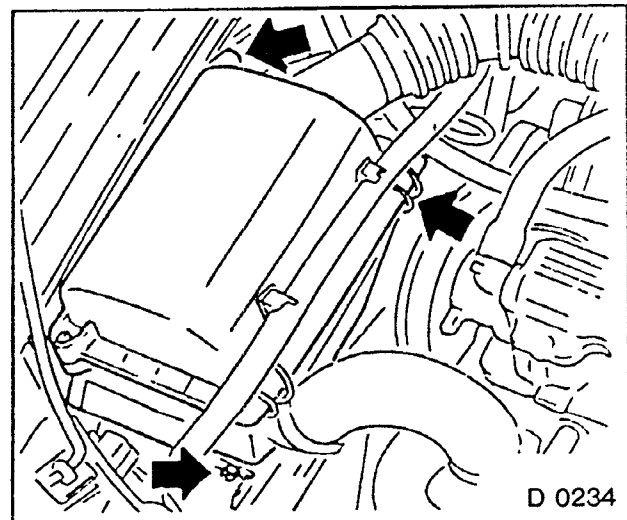


Fig. 106

## Hydraulic Pump — Remove and Install

(ON ENGINES ABOVE 1.8 LTR. CAPACITY)

### REMOVE, DISCONNECT

1. V-belt.
2. Pressure.
3. Return hose  
Fluid escapes — close openings
4. Hydraulic pump from main bracket and rear bracket.

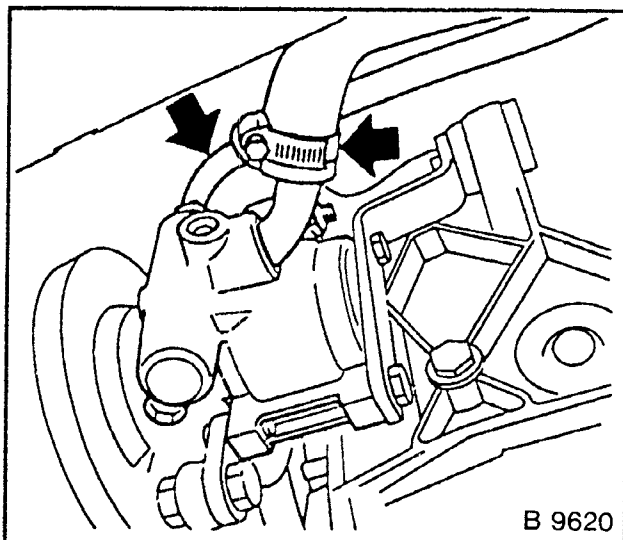


Fig. 107

### TIGHTEN (TORQUE)

1. Hydraulic pump to main bracket and rear bracket — 25 Nm.

### INSTALL, CONNECT

1. V-belt — check condition, replace if necessary, see operation “V-belt for Hydraulic Pump, Replace”, page 44

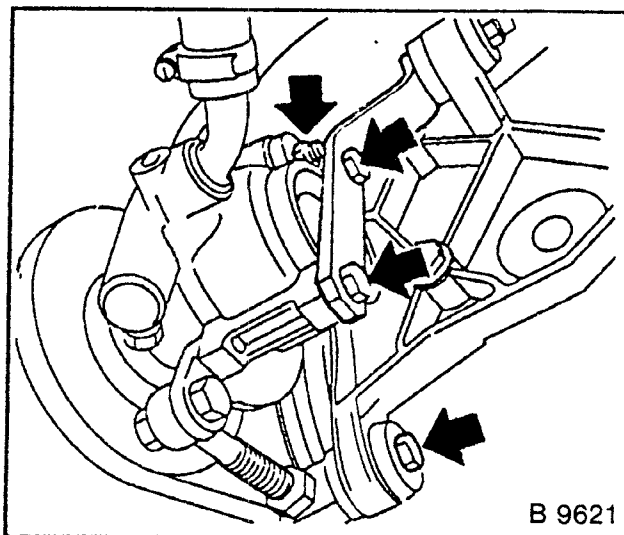


Fig. 108

## Hydraulic Pump — Remove and Install

VEHICLES WITH AC

### REMOVE, DISCONNECT

1. V-belt for hydraulic pump.
2. Pressure and return hoses — fluid escapes. Close openings.
3. Tensioning screw from engine block (arrow)

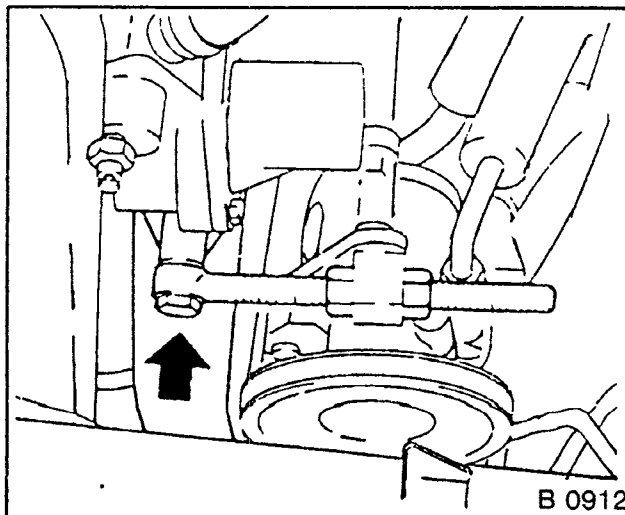


Fig. 109

4. Fastening bolts (long, Fig. 110/arrow) from bracket and compressor

When replacing pump, convert bracket frame with tensioning screw.

### INSTALL, CONNECT

1. Fastening bolts (long, arrow) to bracket and compressor, tensioning screw to engine block — place in at first
2. V-belt for hydraulic pump

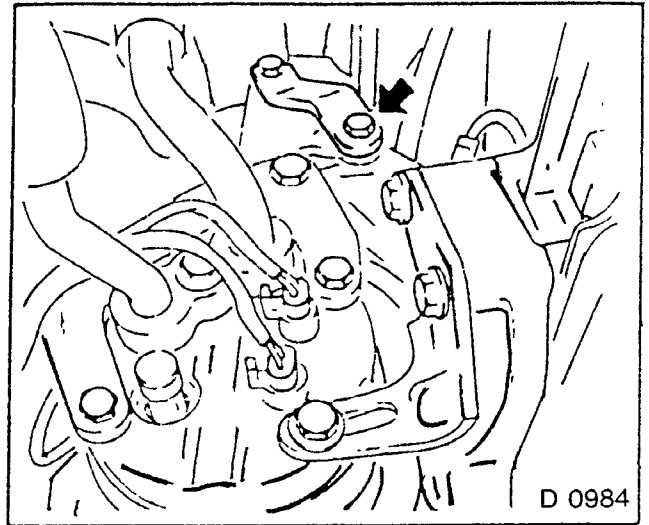


Fig. 110

### TIGHTEN (TORQUE)

1. Tensioning screw to engine block — 40 Nm.
2. Lock nut to tensioning screw — 40 Nm.
3. Fastening bolts (long) to bracket — 25 Nm.
4. Expandable hose to hydraulic pump — 28 Nm.
5. Return hose to hydraulic pump — tighten hose clamp so that it does not leak.
6. Top up and bleed hydraulic pump.

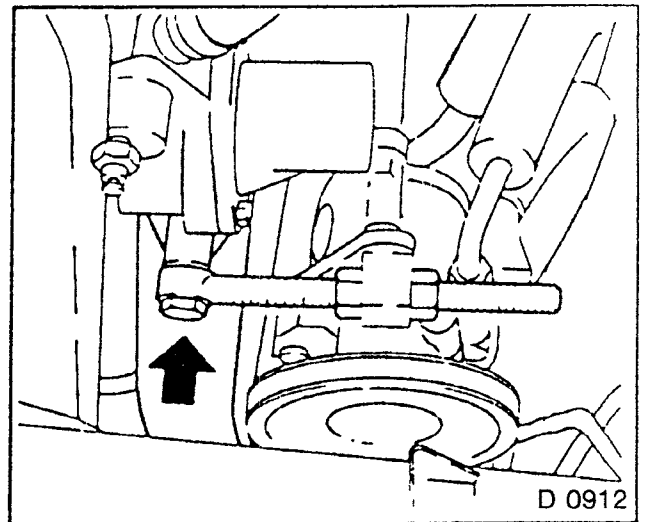


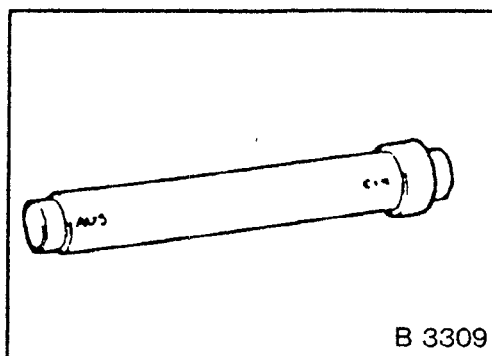
Fig. 111



## Special Service Tools

### KM — 108 REMOVER/INSTALLER.

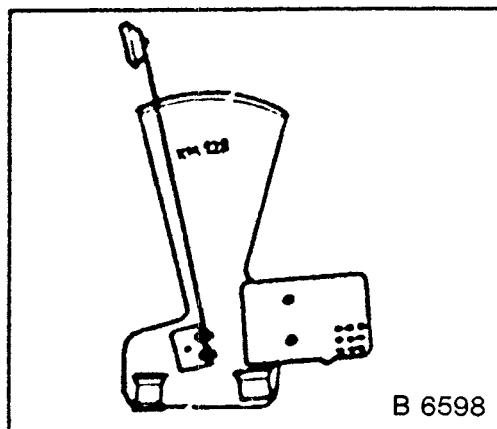
To remove and install upper steering shaft bearing.



B 3309

### KM — 128 — A BELT TENSION GAUGE.

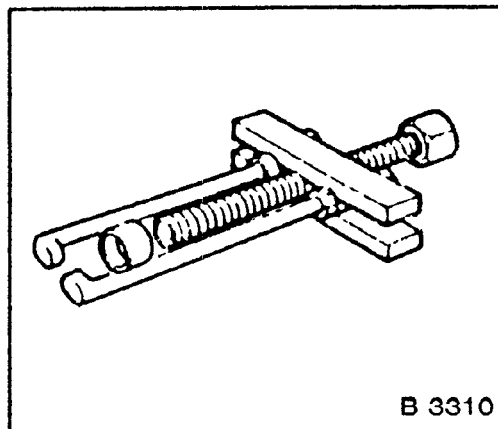
To check V-belt tension.



B 6598

### KM — 210 — A STEERING WHEEL PULLER.

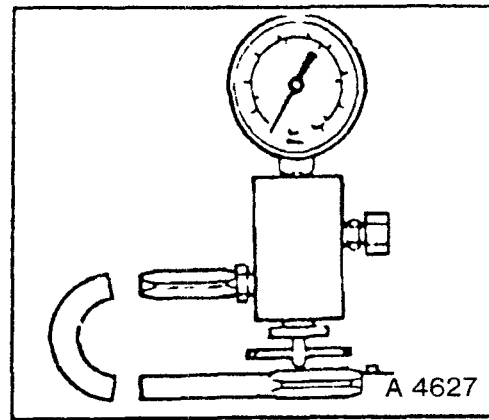
To remove steering wheel.



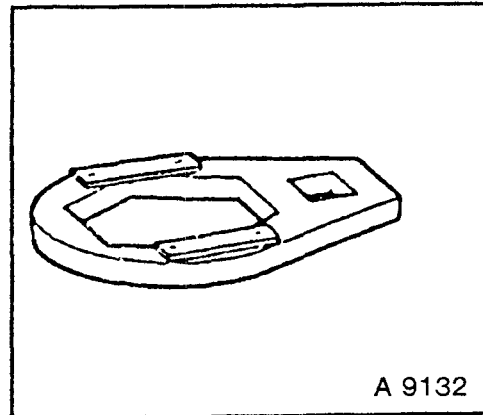
B 3310

**KM — 354 — B PRESSURE TEST KIT.**

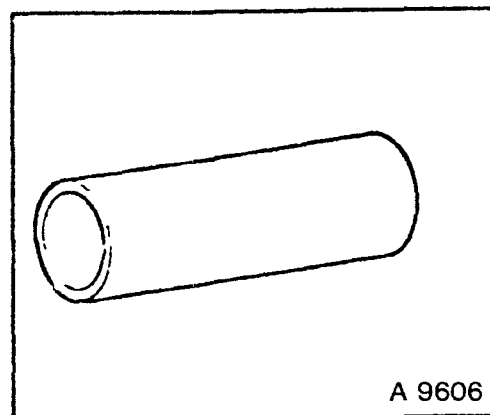
To check power steering fluid pressure.

**KM — 472 COUNTER NUT WRENCH.**

With torque wrench with ratchet.  
To loosen and tighten hex lock nut.

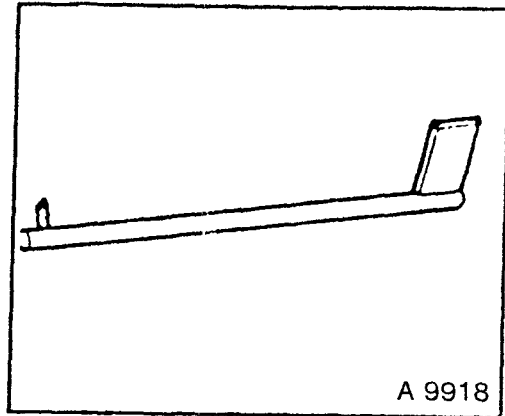
**KM — 473 INSTALLING TUBE.**

To install retaining ring into steering gear.

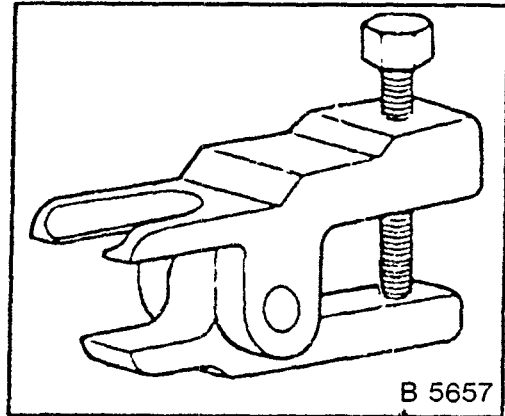


**KM — 476 REFERENCE GAUGE.**

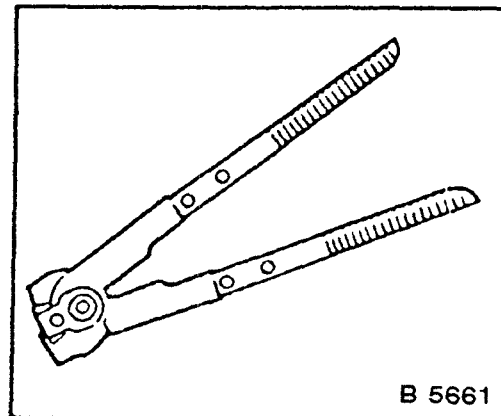
To check steering straight ahead position.

**KM — 507 — C BALL JOINT REMOVER.**

To remove tie rod joint from tie rod lever.

**KM — J — 22610 CLAMPING PLIERS.**

To clamp retaining band for fastening of folding cover

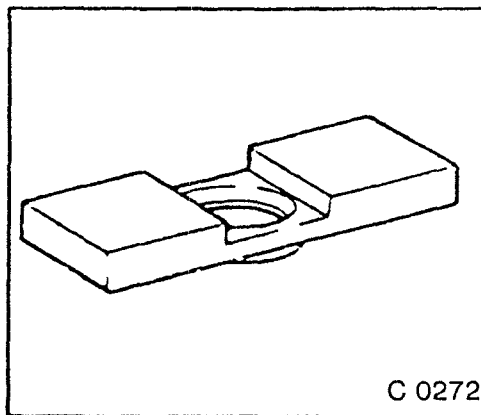


**KM — 583      ADAPTER.**

With KM — J — 23653 — A

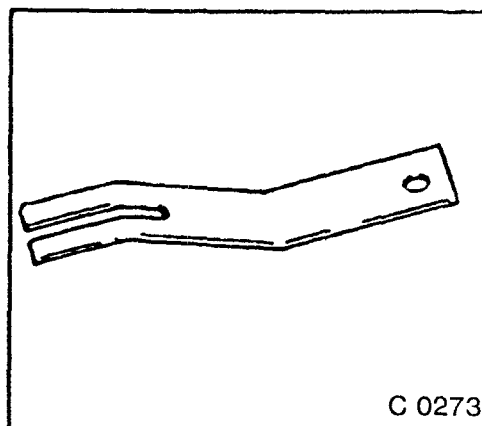
To remove and install retaining ring to steering shaft.

Steering column with "height adjustable steering wheel".

**KM — 584      REMOVER/INSTALLER.**

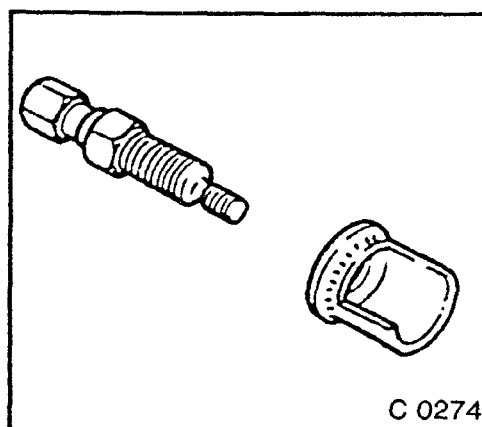
To remove and install pressure spring for height adjustment.

Steering column with "height adjustable steering wheel".

**KM — 585      REMOVER.**

To remove both fulcrum bearing pins from bearing housing.

Steering column with "height adjustable steering wheel".



## TECHNICAL DATA

### Manual Steering Gear

|                       |                        |                       |               |
|-----------------------|------------------------|-----------------------|---------------|
| Total steering ratio: |                        | Pinion identification | Steering rack |
| Standard version:     | 22 : 1                 | no groove             | 28 teeth      |
| Special version:      | 24.5 : 1               | 1 groove              | 32 teeth      |
| Lubricant:            | <b>STEERING GREASE</b> |                       |               |
| Filling quantity:     | Approximately 50 g.    |                       |               |

### Steering Shock Absorber

|                         |  |
|-------------------------|--|
| Design:                 | Piston shock absorber  |
| Installation:           | Parallel to steering gear  |
| Installation dimension: | 12.5 to 13.5 mm from front edge of rubber damper plate to front edge of piston rod |

### Hydraulic Steering Gear

|   |   |
|---|---|
| Manufacturer:   | Saginaw   |
| Variants:   | Right-hand drive  |
| Total steering ratio:   |   |
| Standard version:   | 18 : 1  |
| Special version:  | 18 : 1, Lower actuating force is attained hydraulically |
| Fluid quality:  | <b>SPECIAL FLUID</b>                                    |
| Fluid filling quantity:   | Approximately 1.0 litre                                 |
| Fluid pressure at steering wheel full lock/<br>checking pressure for centre position: | 95 to 100 bar   |
| V-belt  | Dimensions: 9.5 x 850 mm                                |
|   | Tension: Run-in V-belt: 250 to 300 N                    |
|   | New V-belt on installation: 450 N                       |
| Ribbed V-belt:  | Dimensions: 17.8 x 1015 mm                              |
|   | Tension: Run-in belt: 50 Nm                             |
|   | New belt: 55 Nm   |

## Recommended Torque Values

Nm

|   |      |
|---|------|
| Alternator tensioning bolt to bracket — version with ribbed V-belt.....         | 25   |
| Bolt, pinion fastening .....  | 40   |
| Bolt, steering column bracket to bulkhead.....                                  | 22   |
| Bolt, tensioner to retaining bracket .....                                      | 25   |
| Bolt, tensioning bolt to hydraulic pump .....                                   | 40   |
| Bolt, tie rod to steering gear. ....  | 95   |
| Bolts, alternator to bracket — version with ribbed V-belt . ...                 | 30   |
| Bolts, both damping brackets for steering shock absorber to steering gear ..... | 12   |
| Bolts, fluid reservoir bracket to battery support and front frame.....          | 7    |
| Bolts, hydraulic pump bracket to retaining bracket... ..                        | 25   |
| Bolts, pulley to hub of hydraulic pump — version with ribbed V-belt. ..         | 25   |
| Bolts, retaining bracket to cylinder block .....                                | 40   |
| Bolts, steering gear retaining bracket to bulkhead .....                        | 22   |
| Clamp bolt, steering pinion to steering coupling . . . . .                      | 22   |
| Clamp bolt, steering shaft to steering coupling. . . . .                        | 22   |
| Clamp bolt, tie rod.....  | 20   |
| Fastening, tie rod joint to tie rod lever .....                                 | 60   |
| Hex lock nut for adjusting bolt .....   | 60   |
| Hollow bolt, pressure and return lines to steering gear, ZF .....               | 37.5 |
| Hydraulic pump to cylinder block — version with ribbed V-belt.....              | 30   |
| Nut, lock nut, tensioning bolt to tensioner.....                                | 40   |
| Nut, right, shear plate attachment .....  | 22   |
| Nut, steering wheel to steering shaft.....                                      | 25   |
| Nuts, steering gear to bulkhead ..  | 22   |
| Union nut, expandable hose to pressure line.....                                | 28   |
| Union nut, pressure and return lines to steering gear, right-hand drive ..      | 42.5 |
| Union nut, pressure and return lines to steering gear, Saginaw .....            | 28   |
| Union nut, pressure line to hydraulic pump connection.. . . . .                 | 28   |

# **Opel Astra** **Opel Kadett**

## **Workshop Manual**

### **Section R**

# **Body Equipment**

Issued by: Service Division  
Delta Motor Corporation  
July, 1993

# Index

|   | <b>Page</b> |
|---|-------------|
| <b>GENERAL INFORMATION FOR SERVICE INSTALLATION OF ACCESSORIES</b> .....  | R- 2        |
| <b>TRAILER HITCH</b>  |             |
| TRAILER HITCH, SERVICE INSTALL (MECHANICAL EQUIPMENT) .....   | R- 3        |
| <b>ANTENNA</b>  |             |
| AUTOMATIC ANTENNA, SERVICE INSTALL .....  | R- 5        |
| ROD ANTENNA, SERVICE INSTALL (KADETT) .....   | R- 6        |
| ROD ANTENNA, SERVICE INSTALL (ASTRA) .....  | R- 7        |
| <b>OUTSIDE REAR VIEW MIRROR</b>   |             |
| MIRROR COVER, REMOVE AND INSTALL .....  | R-10        |
| MIRROR GLASS, REPLACE .....   | R- 9        |
| MIRROR MOTOR, REPLACE .....   | R-10        |
| OUTSIDE REAR VIEW MIRROR, REPLACE .....   | R- 8        |
| RELAY FOR MIRROR HEATING, REPLACE .....   | R- 8        |
| SWITCH FOR MIRROR ACTUATION, REPLACE .....  | R- 9        |
| <b>RADIO, LOUDSPEAKERS</b>  |             |
| BASS LOUDSPEAKERS IN FRONT DOORS, REPLACE .....   | R-13        |
| RADIO, SERVICE INSTALL .....  | R-13        |
| REAR LOUDSPEAKERS, REPLACE (KADETT) .....   | R-12        |
| REAR LOUDSPEAKERS, REPLACE (ASTRA) .....  | R-12        |
| TREBLE LOUDSPEAKERS IN FRONT DOORS, REPLACE .....   | R-13        |
| <b>AUXILIARY LIGHTING</b>   |             |
| FOG LAMP, SERVICE INSTALL (VEHICLES WITH PREPARED "BODY" AND "INSTRUMENT PANEL"<br>WIRING HARNESSSES) .....           | R-16        |
| FRONT FOG LAMPS, SERVICE INSTALL (VEHICLES WITHOUT PREPARED "BODY" AND<br>"INSTRUMENT PANEL" WIRING HARNESSSES) ..... | R-18        |
| FRONT FOG LAMP, ADJUST .....  | R-21        |
| FRONT FOG LAMP SWITCH, REPLACE .....  | R-21        |
| FRONT FOG LAMP BULB, REPLACE .....  | R-16        |
| FRONT FOG LAMP, REPLACE .....   | R-16        |
| RELAY — FRONT FOG LAMPS, REPLACE .....  | R-22        |
| LAMPS — CIRCUIT DIAGRAM .....   | R-24        |
| <b>SPECIAL SERVICE TOOLS</b> .....  | R-25        |



## General Information for Service Installation of Accessories

When drilling or cutting holes in the body, the rough edges must be deburred and painted afterwards. Metal cuttings caused by drilling are to be removed from the body. Trim strips near the drilling point are to be covered to prevent cuttings from lodging between the trim strip and the paint, where weathering would lead to rust and destruction of the paint.

To avoid short circuits during operations involving the fuse box or leads that are not protected by a fuse, disconnect the ground cable from the battery and place it aside.

After reconnecting the battery, re-programme all electronic components (e.g. electric window winders, clock, board, computer, radio).

In order to guarantee a low level of noise after installation of accessories, the following must be observed when laying new cable:

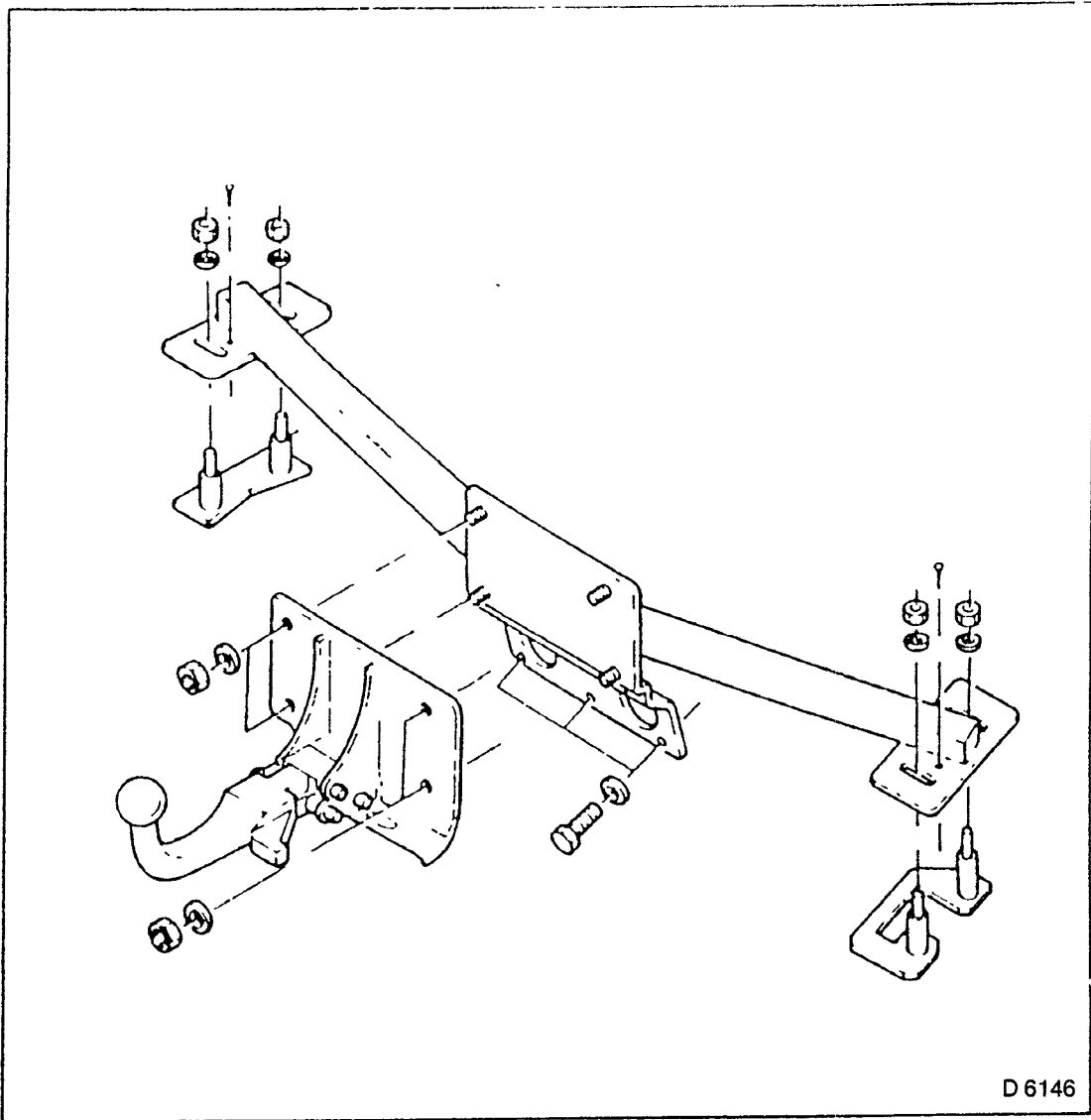
- Lay electrical connecting cables with cable straps, clamps, insulating tape in standard wiring harness.
- Protect individual cables behind the instrument panel with self-adhesive foam strips, if necessary.
- It is important that a minimum distance of 10 mm be kept between the brake lines and fixed cables and a distance of 25 mm between the brake lines and cables which move with the engine or other components

The usual rules are to be observed when connecting cable terminals and multiple plugs or for laying cables in the vehicle.

When installing additional electrical consumers, it is necessary to check in each case whether the existing alternator can handle the additional load. If necessary, the alternator should be replaced by one of a higher capacity.

# TRAILER HITCH

## MECHANICAL EQUIPMENT — KADETT



D6146

Fig. 1

## MECHANICAL EQUIPMENT — ASTRA

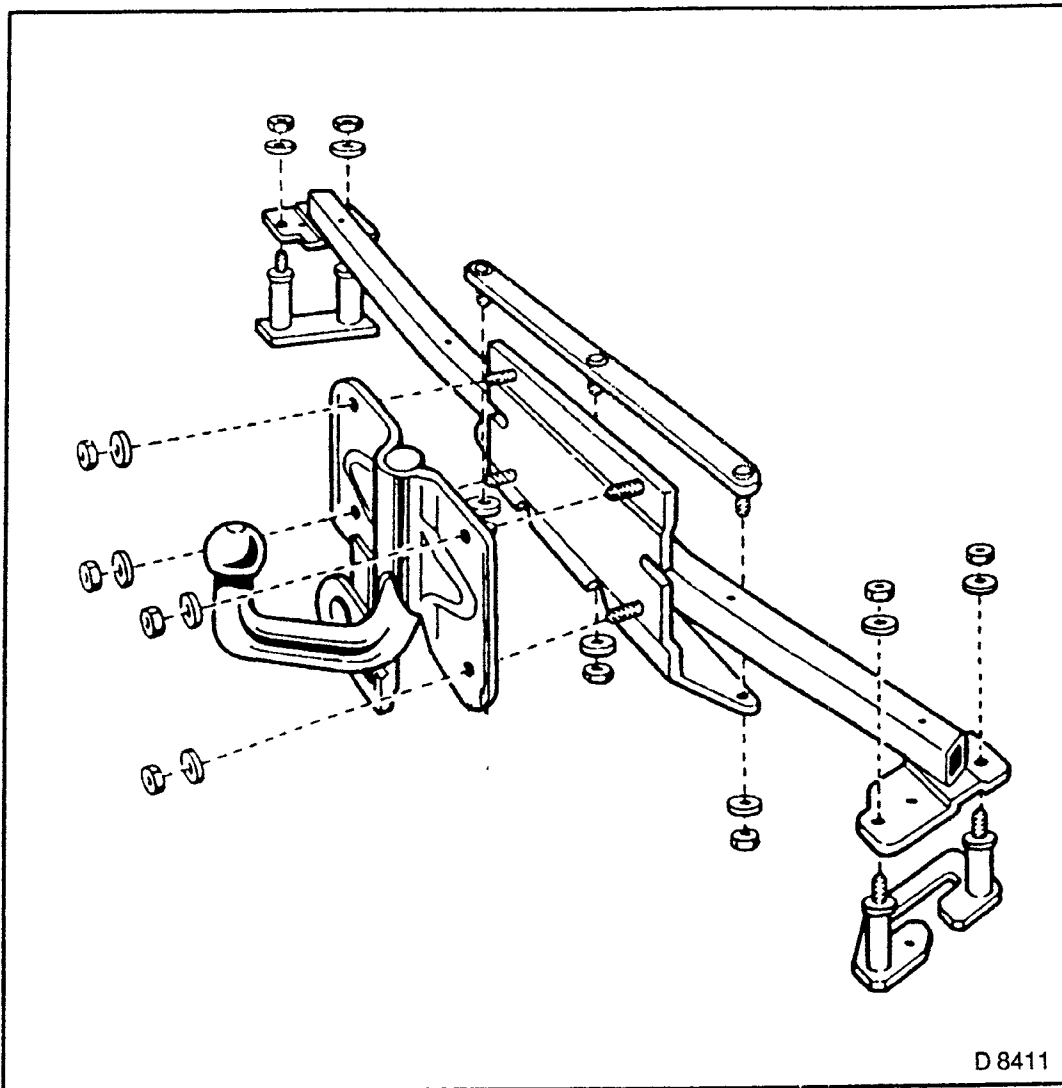


Fig. 2

### REMOVE, DISCONNECT

1. Luggage compartment carpet.
2. Rear panel inner trim.
3. Pull off rubber seal
4. Rear panelling.
5. Nuts in luggage compartment.
6. Bolts in wheel arch.
7. If present — pull off wiring plug from license plate lamp.
8. If present — insulating material from luggage compartment floor — heat with hot air blower and remove.

The fitting instructions for towbars are to be obtained from the towbar manufacturers.

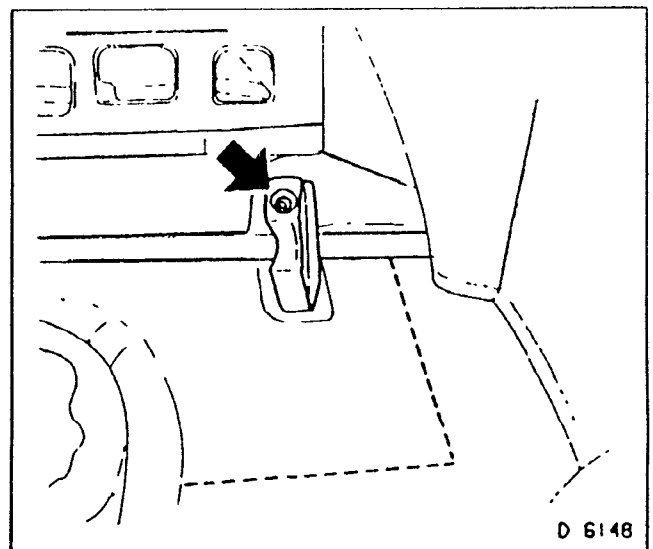


Fig. 3

# ANTENNA

## Automatic Antenna — Service Install

### REMOVE, DISCONNECT

1. Ground cable from battery.
2. Rear left side panelling.
3. Left rear lamps.
4. Closure plugs for antenna holes.
5. Front and rear sill panelling.

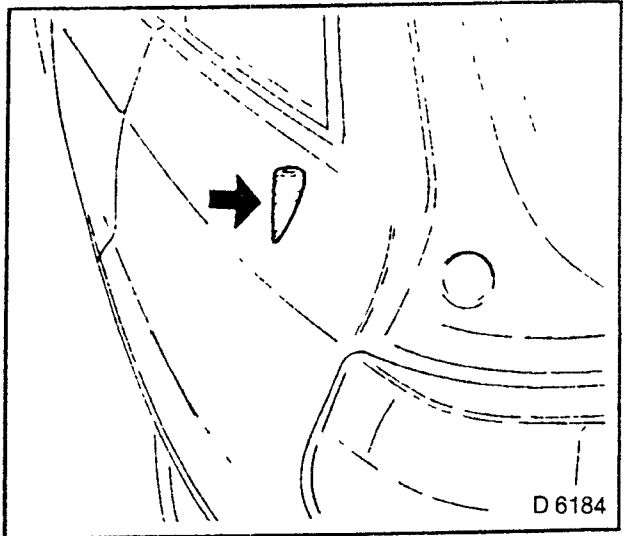


Fig 4

### INSTALL, CONNECT

1. Rubber grommet in antenna hole.
2. Antenna in rubber grommet.
3. Antenna to inner rear quarter panel.
4. Antenna cable.
5. Lay cable via left sill panel and front rear quarter panel to radio.

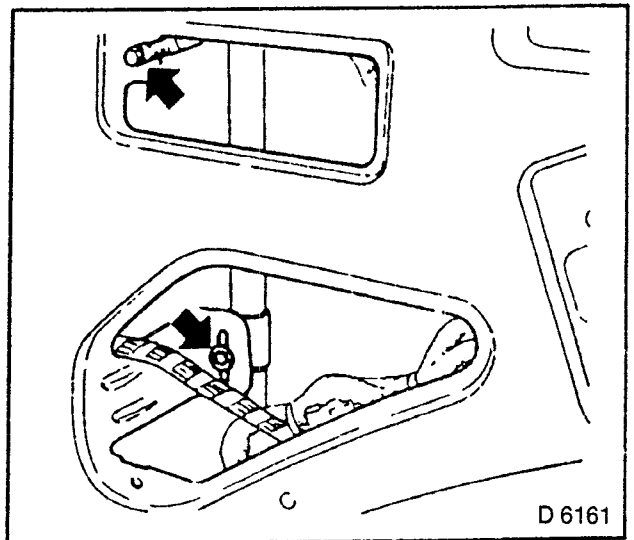


Fig 5

### REMOVE, DISCONNECT

1. Ground cable from battery.
2. Rear left cover.
3. Antenna hole closure plug (Fig 6 shows Astra).
4. Front and rear sill panelling.

### INSTALL, CONNECT

1. Rubber grommet in antenna hole — note installation position.
2. Antenna cable to antenna.
3. Antenna in rubber grommet.
4. Bolt antenna to inner rear quarter panel.
5. Route antenna cable along body wiring harness to radio.

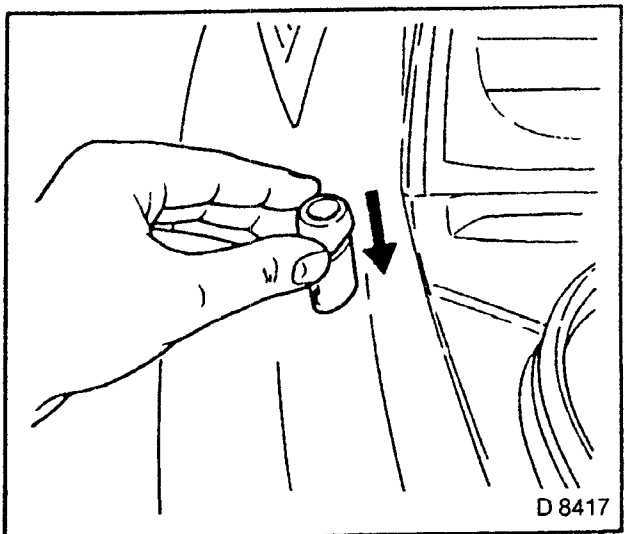


Fig. 6

## ELECTRICAL CONNECTIONS

### VARIANT 1

#### ALL ELECTRICAL CABLES PRESENT

### INSTALL, CONNECT

1. Wiring harness plug from "rear receiver" or "antenna" wiring harness to antenna.
2. Ground cable to inner rear quarter panel.

### VARIANT 2

#### NO ELECTRICAL CABLES PRESENT

### INSTALL, CONNECT

1. Electrical connections to antenna.
  - A — Constant current to fuse box (fuse no. 24)
  - B — Control cable to radio or adapter cable.
  - C — Ground cable to inner rear quarter panel.
2. Side panelling.
3. Rear lamps.
4. Ground lead to battery.

## Rod Antenna — Service Install (Kadett)

### REMOVE, DISCONNECT

1. Rear left rear quarter panelling.
2. Closure plug from antenna hole.

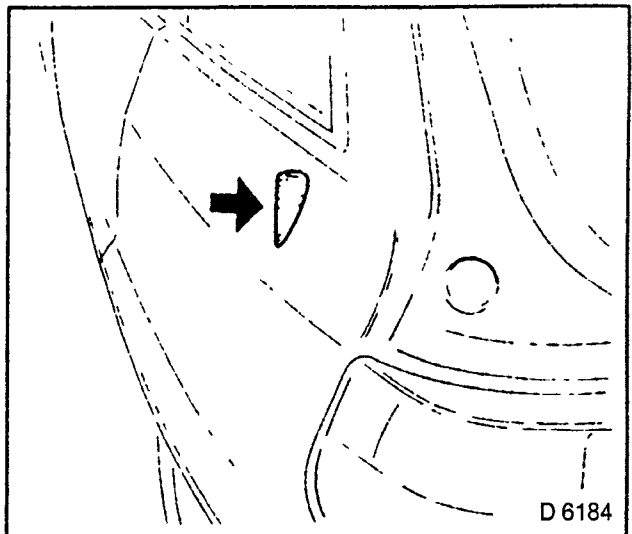


Fig. 7

**INSTALL, CONNECT**

1. Rubber grommet into antenna hole.
2. Antenna into rubber grommet.
3. Antenna on inner rear quarter panel.
4. Antenna cable.
5. If necessary — lay cable via left sill panel and front rear quarter panel to radio

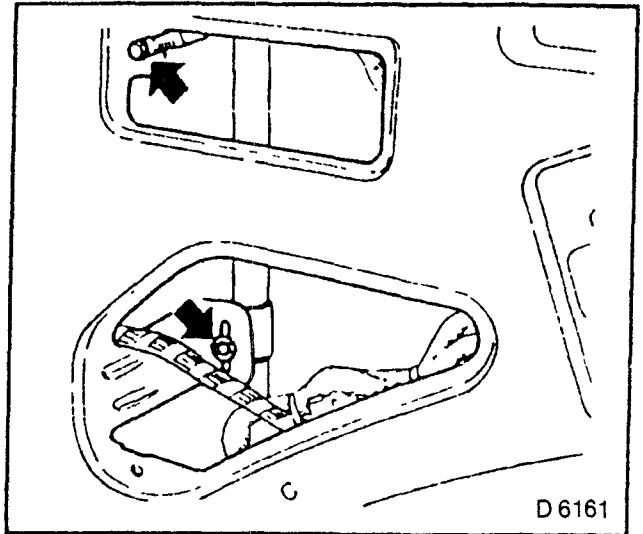


Fig. 8

**Rod Antenna — Service Install (Astra)**

**REMOVE, DISCONNECT**

1. Rear left cover.
2. Closure plug from antenna hole.
3. Front and rear sill panelling.

**INSTALL, CONNECT**

1. Rubber grommet in antenna hole — note installation position.

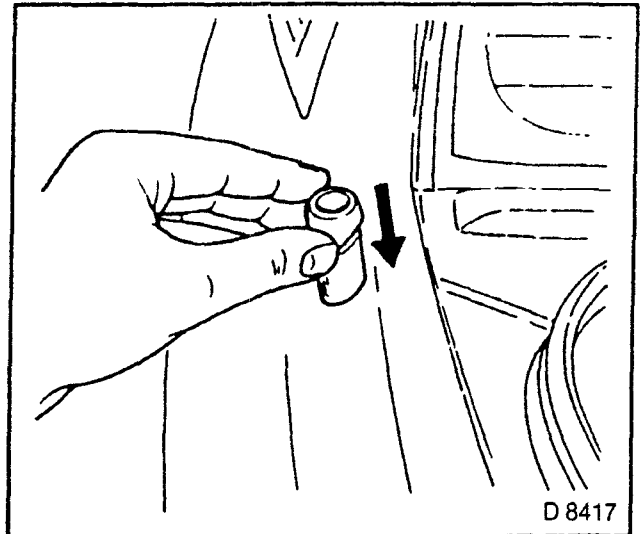


Fig 9

**INSTALL, CONNECT**

1. Antenna cable to antenna (1).
2. Antenna in rubber grommet.
3. Ground strap (2) and antenna (3) to inner rear quarter panel.
4. Route antenna cable along body wiring harness to radio.

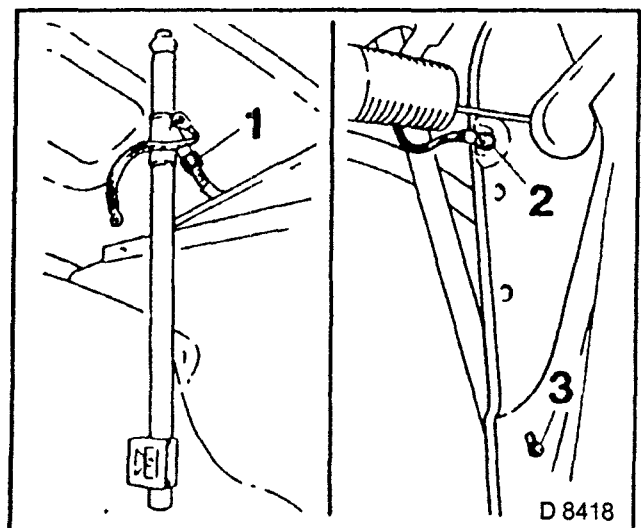


Fig. 10

## OUTSIDE REAR VIEW MIRROR

### Outside Rear View Mirror — Replace

#### REMOVE, DISCONNECT

1. Cover from door.
2. Manual adjustment — remove adjusting lever.

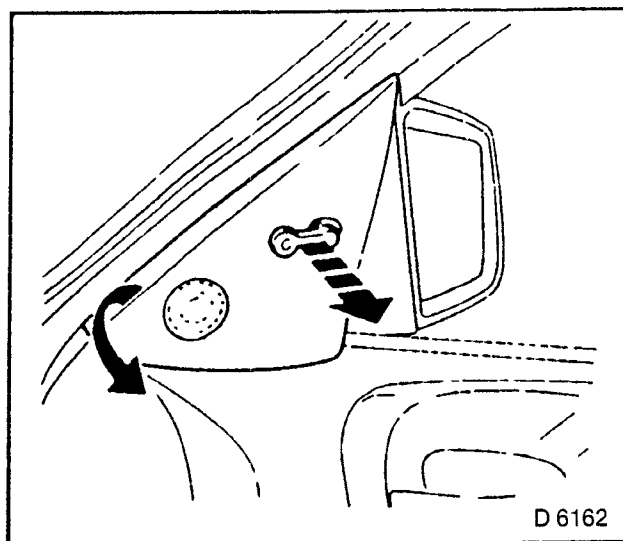


Fig. 11

#### REMOVE, DISCONNECT

1. Screws — if necessary.
2. Release wiring harness plug for mirror motor and remove.
3. Remove mirror.

#### INSTALL, CONNECT

1. Outside rear view mirror.
2. Rubber seal.
3. Wiring harness plug (if present).
4. Bolts.
5. Cover.
6. Adjustment lever (if present).

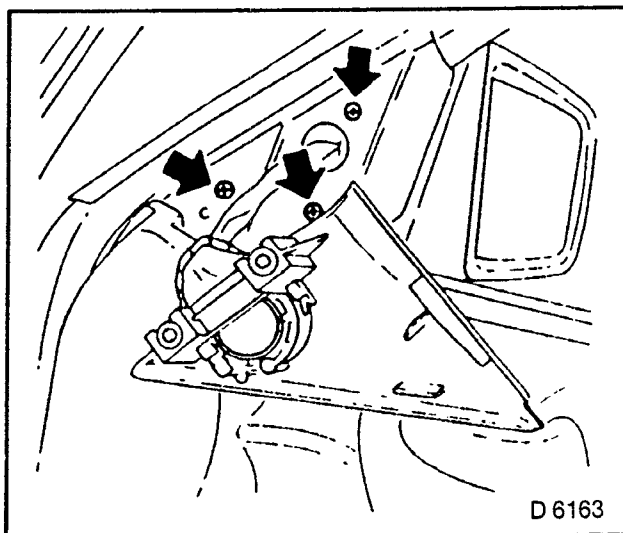


Fig. 12

### Relay for Mirror Heating — Replace

#### REMOVE, DISCONNECT

1. Lower instrument panel trim on driver's side.
2. Release fuse box.
3. Relay

#### INSTALL, CONNECT

1. Relay.
2. Fuse box.
3. Instrument panel trim.

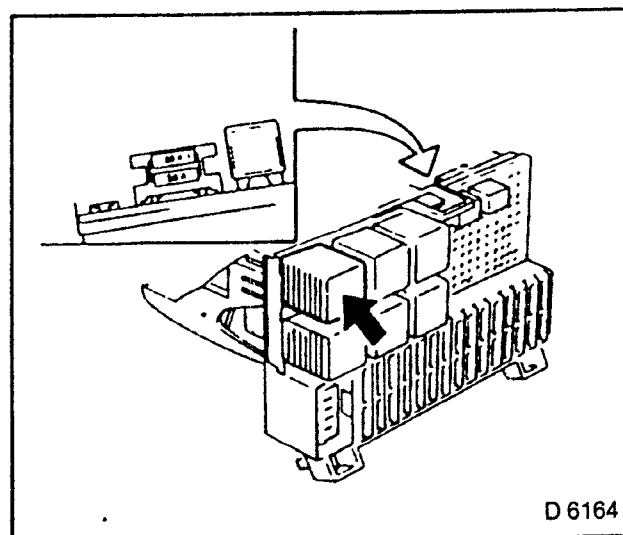


Fig. 13

## Switch for Mirror Actuation — Replace

### REMOVE, DISCONNECT

1. Door inner panelling.
2. Separate wiring harness plug.
3. Switch.

### INSTALL, CONNECT

1. Switch
2. Plug.
3. Door inner panelling.

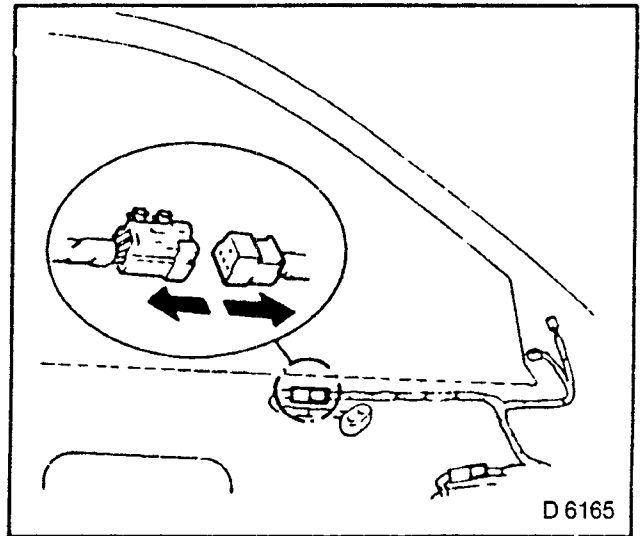


Fig. 14

## Mirror Glass — Replace

### REMOVE, DISCONNECT

1. Lever out mirror glass from outside, if fitted.
2. Remove wiring harness plug for mirror heating.

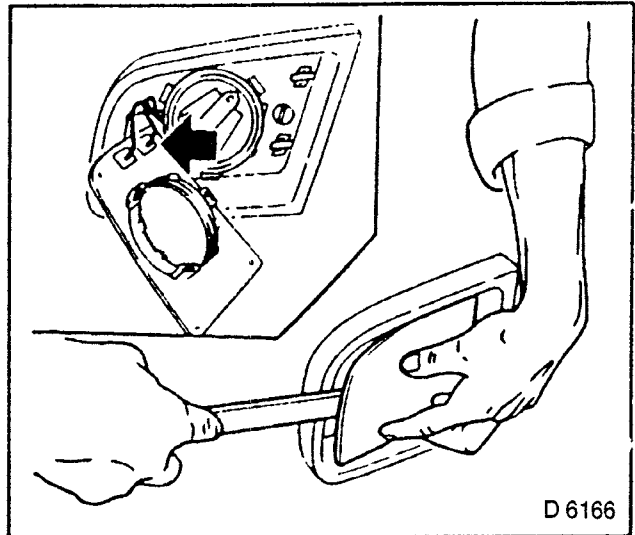


Fig. 15

### INSTALL, CONNECT

1. Wiring harness plug for mirror heating — if fitted.
2. Press on mirror glass.

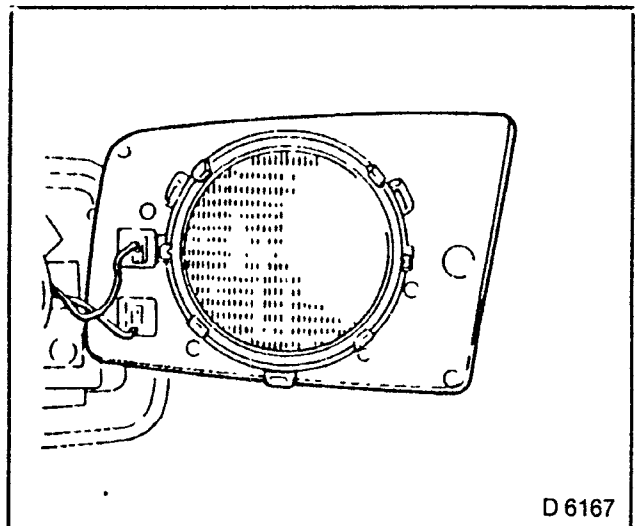


Fig. 16



## Mirror Motor — Replace

### REMOVE, DISCONNECT

1. Mirror glass.
2. Mirror motor.
3. Wiring plug.

### INSTALL, CONNECT

1. Wiring plug (wiring behind motor).
2. Mirror motor
3. Mirror glass.

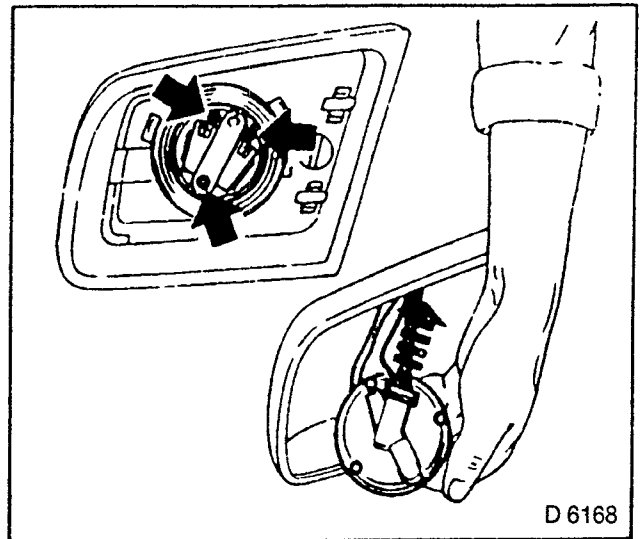


Fig. 17

## Mirror Cover — Remove and Install

### REMOVE, DISCONNECT

1. Counterhold mirror head.
2. Fold backwards with a blow.

**DO NOT DAMAGE DOOR.**

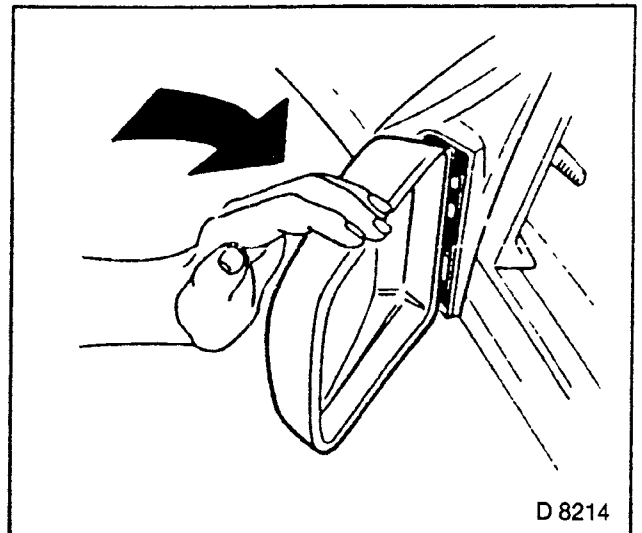


Fig. 18

3. Push in screwdriver at side near catch linkage between inner housing and outer panelling.
4. Lever out catch by turning screwdriver.
5. Remove cover by pulling gently

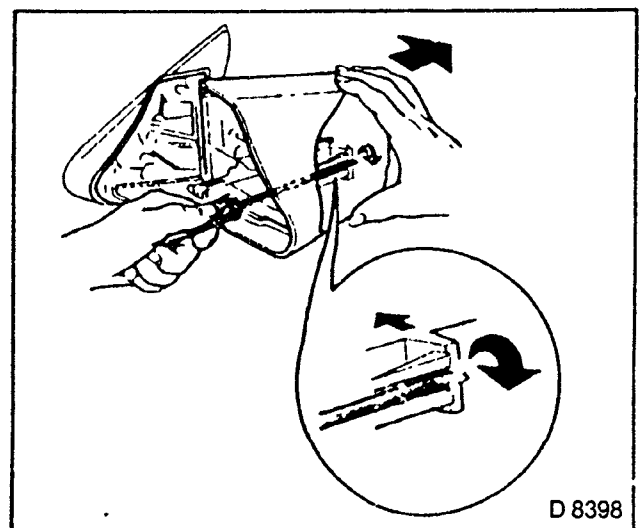


Fig. 19

**INSTALL, CONNECT**

1. Push on cover until it engages audibly.

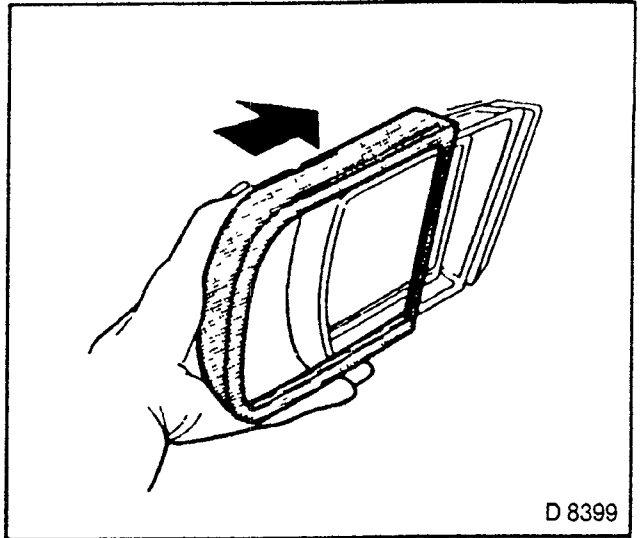


Fig. 20

2. Guide mirror head to catch and hold parallel to mirror base.
3. Engage by striking outside edge with flat of hand.

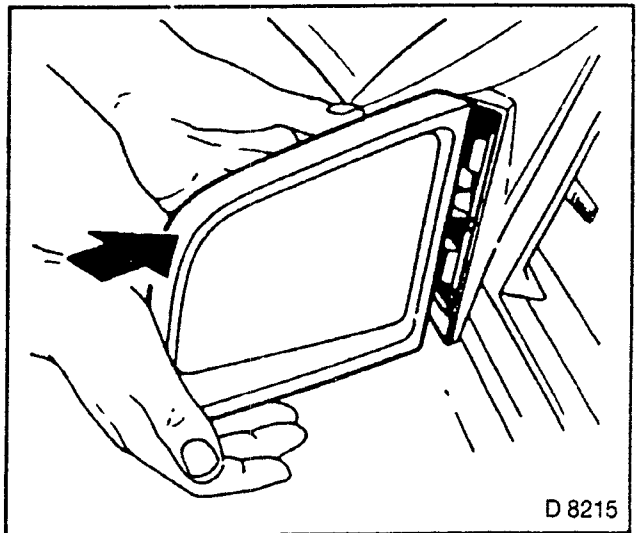


Fig. 21

## RADIO, LOUDSPEAKERS

### Rear Loudspeakers — Replace (Kadett)

#### REMOVE, DISCONNECT

1. Loudspeaker.
2. Wiring harness plug.

#### INSTALL, CONNECT

1. Wiring harness plug.
2. Loudspeaker.

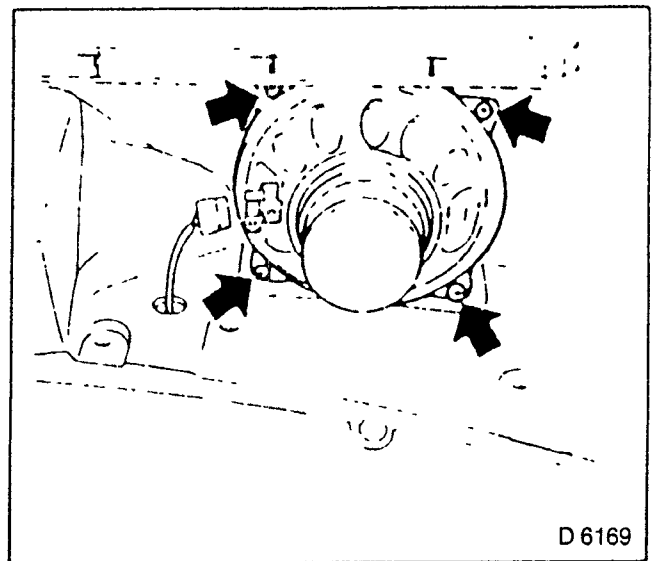


Fig 22

### Rear Loudspeakers — Replace (Astra)

#### REMOVE, DISCONNECT

1. Lift rear loudspeaker cover at front (1).
2. Push aside slightly (2).
3. Pull forward (3).

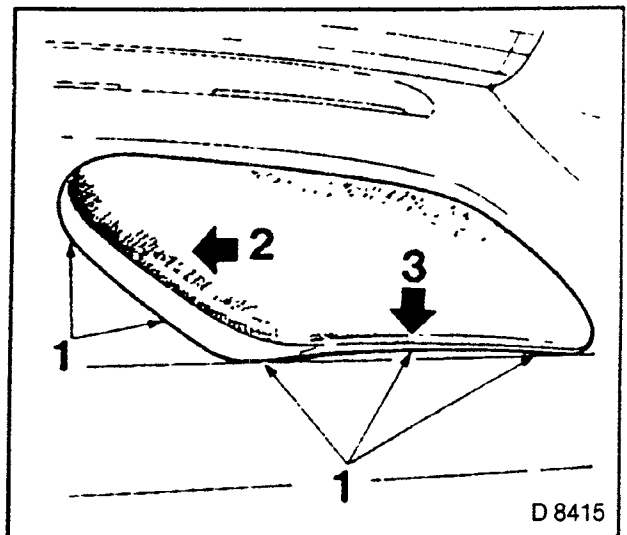


Fig. 23

4. Unscrew rear loudspeaker at top front rear end panel.
5. Wiring harness plug.

#### INSTALL, CONNECT

1. Wiring harness plug.
2. Rear loudspeaker.
3. Rear loudspeaker cover.

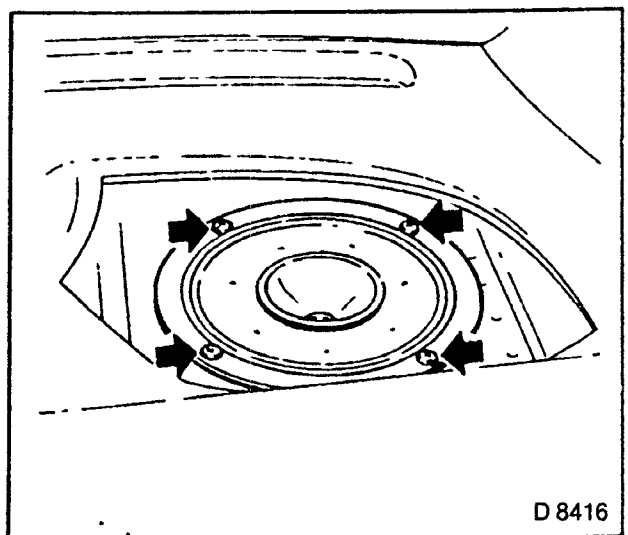


Fig. 24

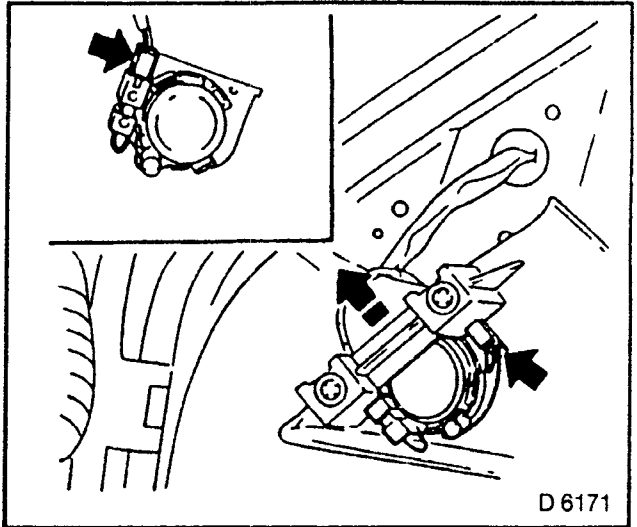
## Treble Loudspeakers in Front Doors — Replace

### REMOVE, DISCONNECT

1. Panel from door.
2. Loudspeaker.
3. Wiring harness plug.

### INSTALL, CONNECT

1. Wiring harness plug.
2. Loudspeaker.
3. Panel.



D 6171

Fig. 25

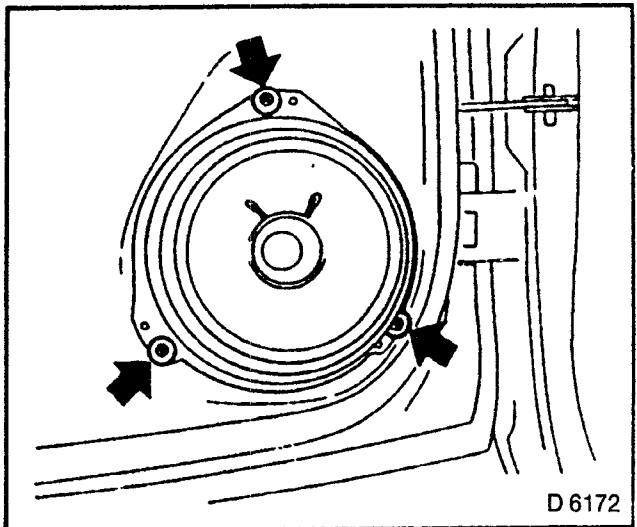
## Bass Loudspeakers in Front Doors — Replace

### REMOVE, DISCONNECT

1. Door inner panelling.
2. Loudspeaker.
3. Wiring harness plug.

### INSTALL, CONNECT

1. Wiring harness plug.
2. Loudspeaker.
3. Door inner panelling.



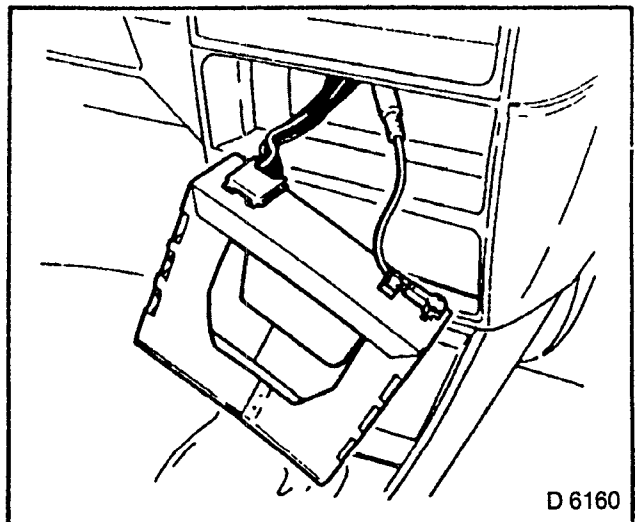
D 6172

Fig. 26

## Radio — Service Install

### REMOVE, DISCONNECT

1. Ground cable from battery.
2. Radio recess cover.



D 6160

Fig. 27

**REMOVE, DISCONNECT**

1. Instrument assembly — Section N.

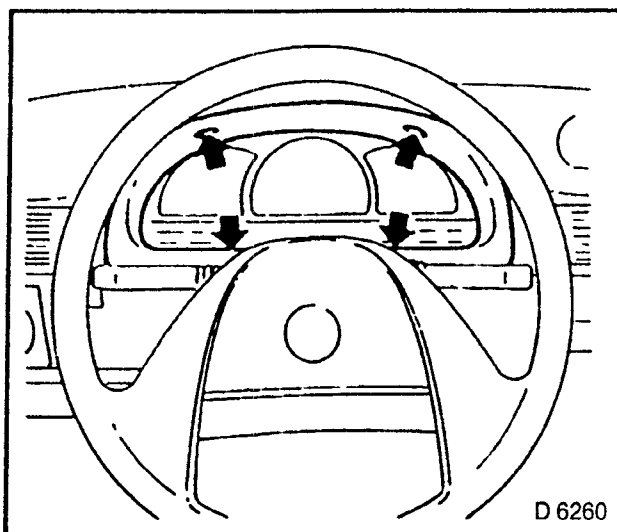


Fig. 28

**ELECTRICAL EQUIPMENT**

No electrical wiring present for installing radio.

**REMOVE, DISCONNECT**

1. Fuse box.

**INSTALL, CONNECT**

1. Constant current wiring (Ter. 30):  
From output of fuse no. 24 to adapter cable.
2. Fuse output = relay side.

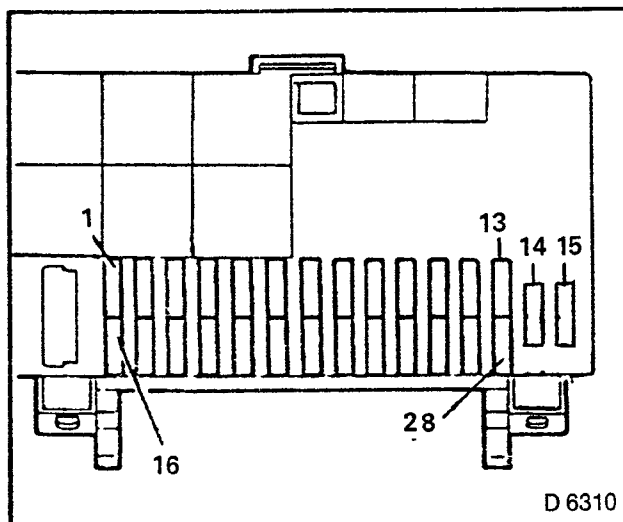


Fig. 29

**INSTALL, CONNECT**

1. Ignition current wiring (Ter. 15):  
From output fuse no 7 to adapter cable.
2. Lighting wiring (Ter. 58):  
From output of fuse no. 18 to adapter cable.
3. Fuse output = relay side.

**INSTALL, CONNECT****1. ANTENNA CABLE.**

2. Ground lead:  
From steering column retainer to adapter cable or radio.
3. Self-tapping screw.
4. Toothed lock washer.
5. Cable terminal.

**INSTALL, CONNECT**

1. If necessary, leads from radio wiring harness ter. 1 to automatic antenna.
2. Loudspeaker connection.  
See installation instructions enclosed with loudspeaker installation set.
3. Antenna cable to radio or adapter cable.

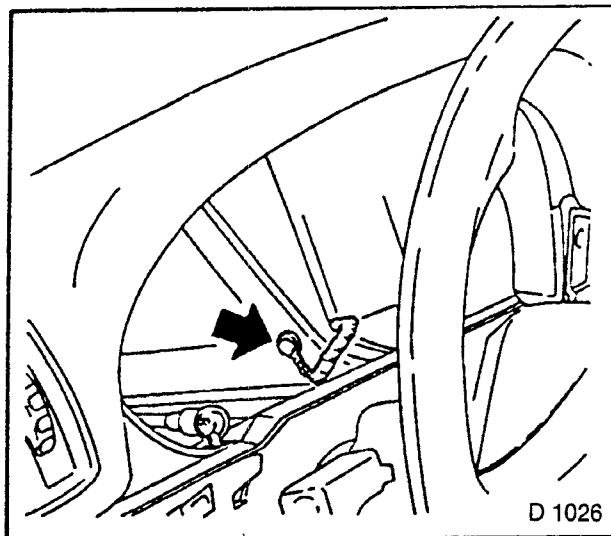


Fig. 30

**INSTALL, CONNECT**

1. Instrument assembly.

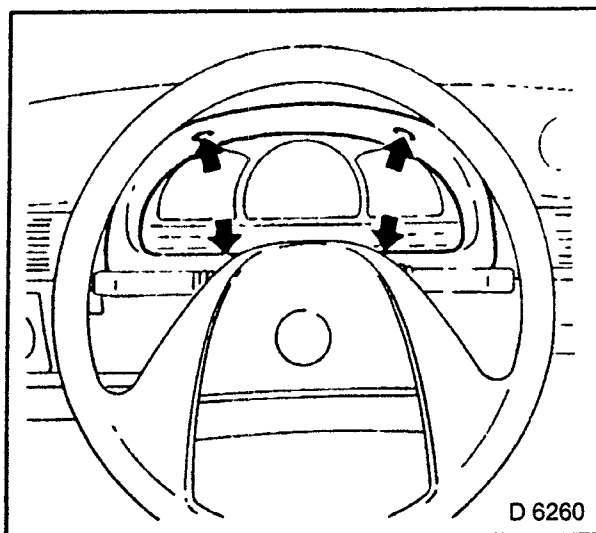


Fig. 31

**INSTALL, CONNECT**

1. Insert wiring harness plug in retaining frame.
2. Insert retaining frame (Fig. 43 shows retaining frame for radio with central plug).
3. Radio.
4. Ground lead to battery.

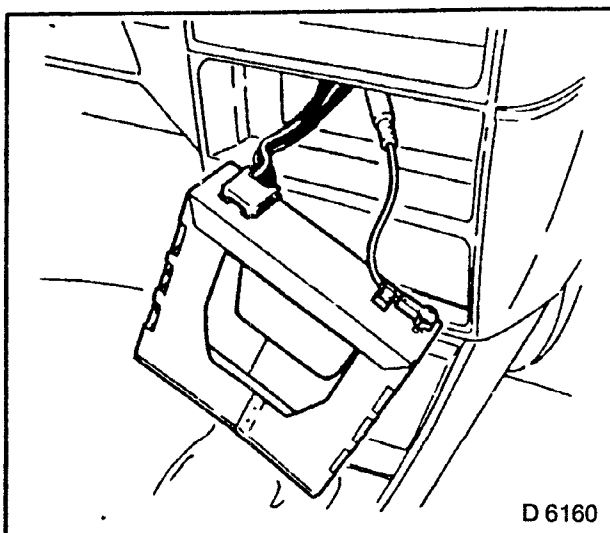


Fig. 32

## AUXILIARY LIGHTING

### Front Fog Lamp Bulb — Replace

#### REMOVE, DISCONNECT

1. Open cover.
2. Remove cable.
3. Bulb from socket.

#### INSTALL, CONNECT

1. Bulb into socket.
2. Connect cable.
3. Close cover.

### Front Fog Lamp — Replace

#### REMOVE, DISCONNECT

1. Wiring harness plug.
2. Fog lamp.

#### INSTALL, CONNECT

1. Fog lamp.
2. Wiring harness plug.
3. Adjust fog lamps.

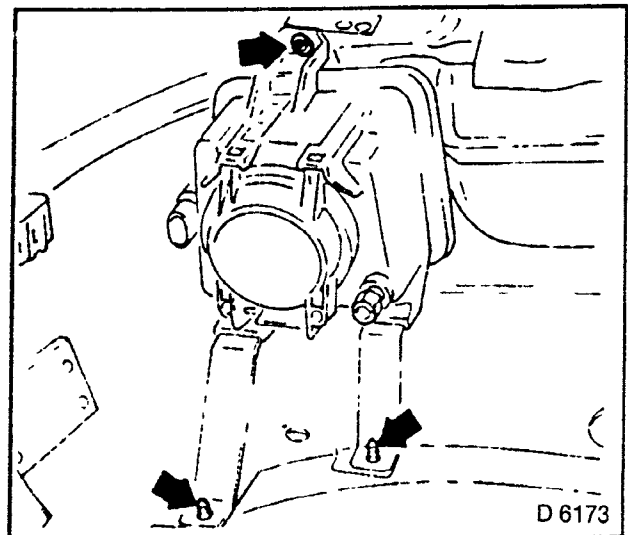


Fig. 33

### Fog Lamp — Service Install

Vehicles with prepared "body" and "instrument panel" wiring harnesses.

#### REMOVE, DISCONNECT

1. Ground lead from battery.
2. Front panelling — Section A.
3. Saw out cut-outs along marking; deburr cut edges.

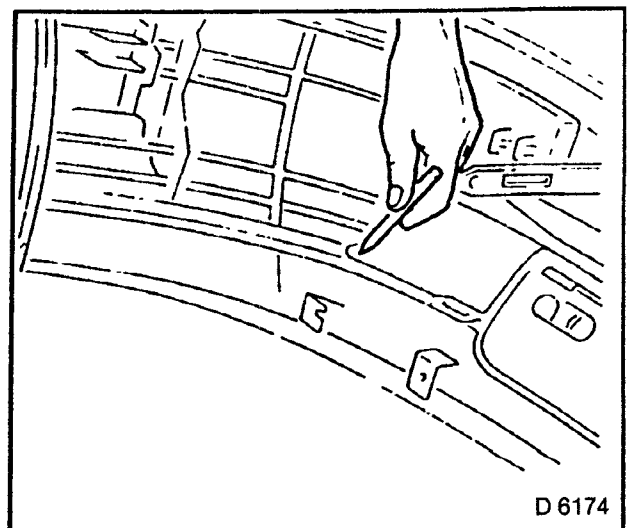


Fig. 34

**INSTALL, CONNECT**

- 1. Fog lamp into front panelling.
- 2. Front panelling.
- 3. Wiring harness plug.

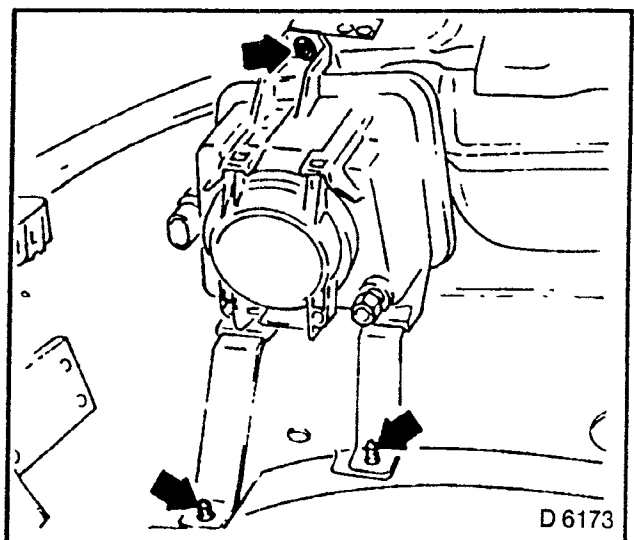


Fig. 35

**INSTALL, CONNECT**

- 1. Fog lamp relay.
- 2. 20 A fuse on position no. 17.

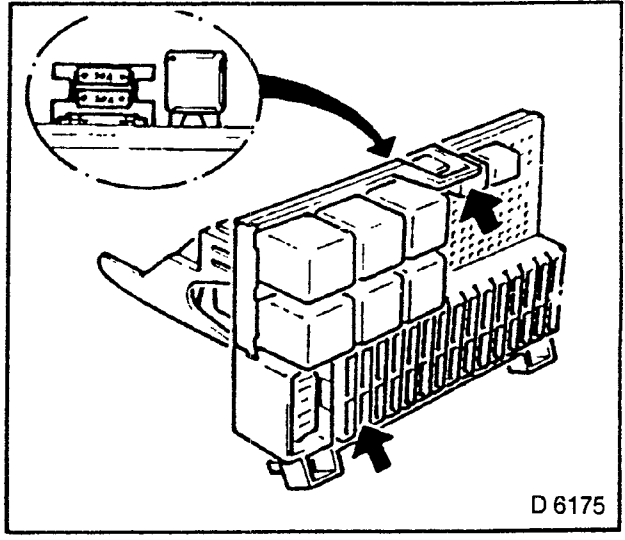


Fig. 36

**REMOVE, DISCONNECT**

- 1. Remove blind cover.

**INSTALL, CONNECT**

- 1. Switch in instrument panel.
- 2. Ground lead to battery.

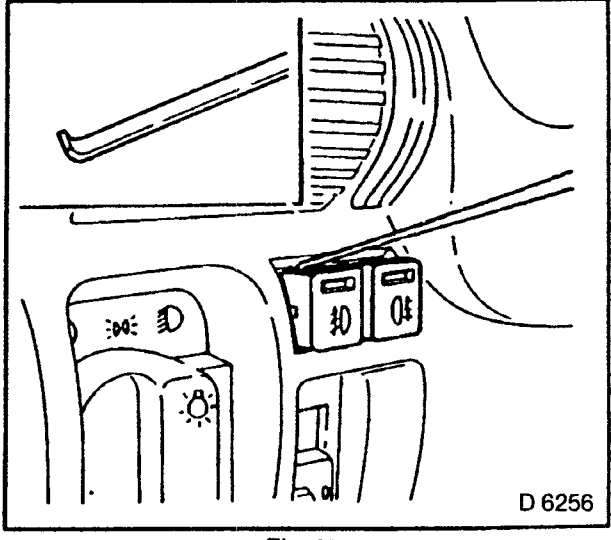


Fig. 37



# Front Fog Lamps — Service Install

Vehicles without prepared "body" and "instrument panel" wiring harnesses.

## REMOVE, DISCONNECT

1. Pull radiator grille forwards (1).
2. Pull lower bracket upwards out of front panelling (2).
3. Headlamp washer system hose (if fitted) (3).

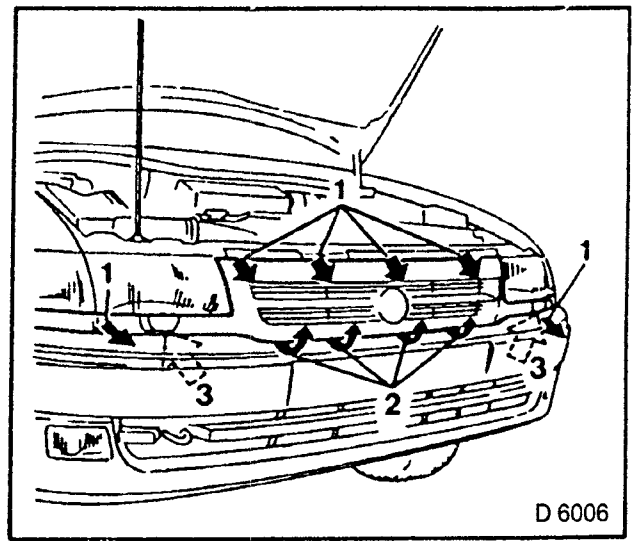


Fig 38

4. Front panelling.  
 To side member — Two nuts.  
 To wheel well — Four bolts.  
 Four body-bound rivets from crossmember — if fitted

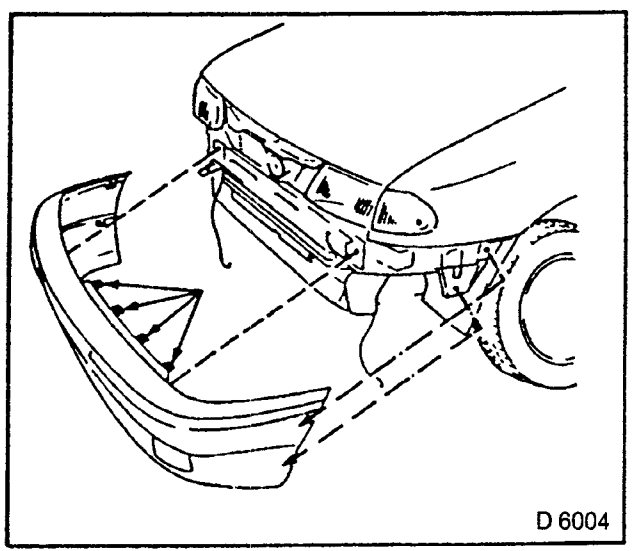


Fig. 39

## REMOVE, DISCONNECT

1. Saw out cutouts along markings.
2. Deburr cut edges.

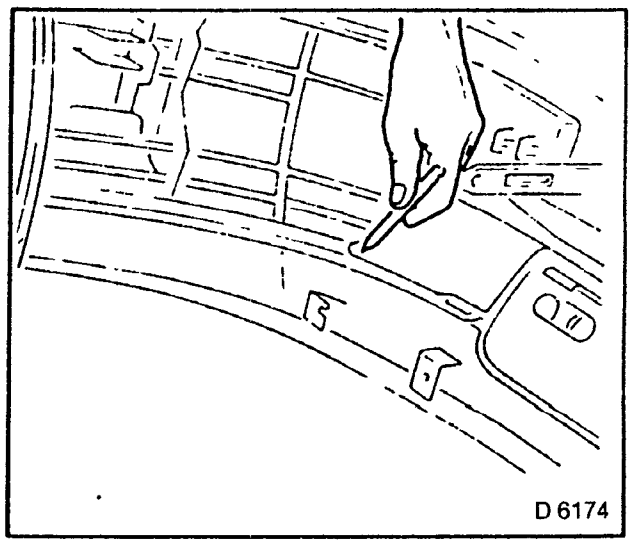


Fig. 40

**INSTALL, CONNECT**

1. Insert tightening nuts at top of front panelling.
2. Fog lamps in front panelling.
3. Front panelling.

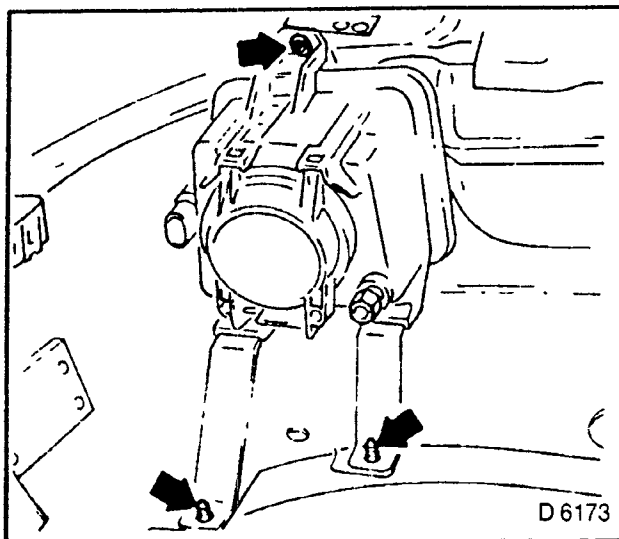


Fig 41

**REMOVE, DISCONNECT**

1. Disconnect battery ground strap.
2. Driver's side footwell panelling.
3. Unscrew fuse box (1).
4. Detach retaining spring (2), turn fuse box forward (reverse accessible).

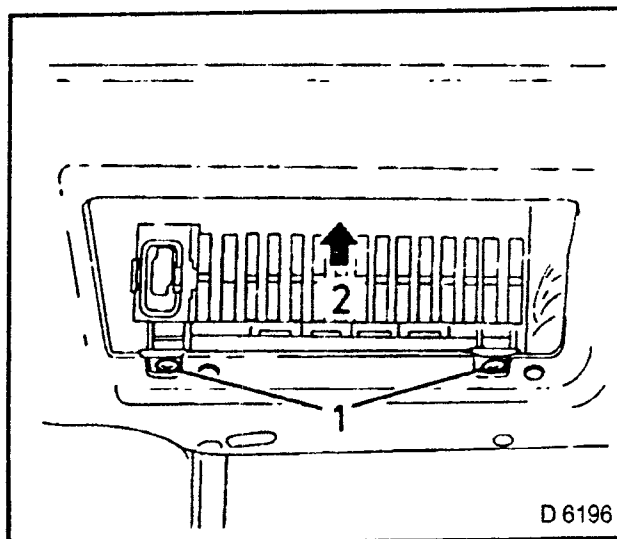


Fig. 42

5. Remove left vent duct housing — Section D.

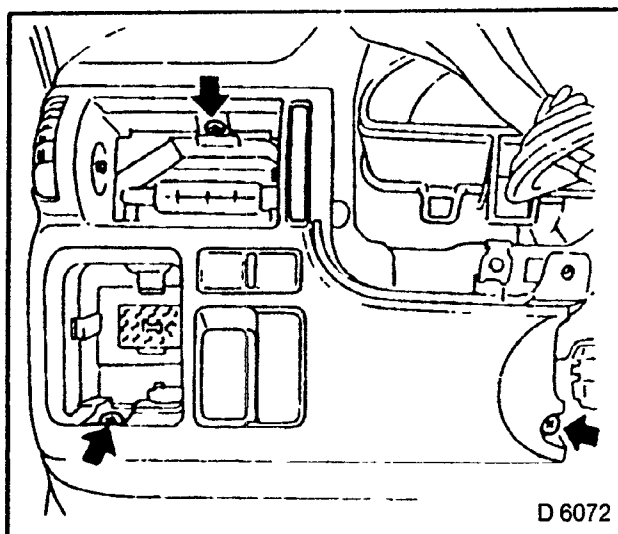


Fig 43

**INSTALL, CONNECT**

1. Connect prefabricated cable with wiring harness plug to front fog lamp.
2. Route cable along body wiring harness next to side of the battery.
3. Bolt ground cable for left and right front fog lamp with battery ground strap to body.
4. Equip positive cable for left and right front fog lamps with flat plug sleeves.
5. Connect 1,5 mm<sup>2</sup> cable to left and right positive cables with flat plug sleeves and flat plugs.
6. Route 1,5 mm<sup>2</sup> cable along body wiring harness to fuse box.
7. Connect to terminal 87 pos. 4 of front fog lamp relay with flat plug 6,3 x 0,8 mm.

**INSPECT**

1. Function of fog lamp.  
The switched on fog lamps illuminate in conjunction with parking lamps, high beam and low beam.
2. The rear fog lamp only illuminates when front fog lamps, high beam and low beam lamps are switched on.
3. The switch symbol on fog lamp switch is illuminated when parking lamp is switched on.
4. The telltale is illuminated when fog lamps are switched on.

**INSTALL, CONNECT**

1. Route 1,5 mm<sup>2</sup> cable along body wiring harness from battery to fuse box. Input of fuse no. 17.
2. Fuse input = underside.
3. Route 1,5 mm<sup>2</sup> cable from output of fuse no. 17 to front fog lamp relay.
4. Connect to pos. 5 with flat plug 6,3 x 0,8 mm.  
Fuse output = relay side.

**INSTALL, CONNECT**

1. Connect cable between:
  - Front fog lamp relay K5 terminal 85 pos. 3 and ground
  - Front fog lamp relay K5 terminal 86 pos. 1 and front fog lamp switch S21 pos. 2
  - Front fog lamp switch S21 pos. 1 and ground
  - Front fog lamp relay, output of fuse 19 and front fog lamp switch S21 pos. 3 and 4
  - Front fog lamp switch S21 pos. 5 and front fog lamp relay K5 terminal 87 pos. 4 (splice connector).
2. Secure contact springs in wiring harness plug with retaining pins.
3. Switch.
4. Fuse box.
5. Insert fuse in pos. 17.
6. Front fog lamp relay.

**ADJUST**

1. Fog lamp.
2. Position vehicle on even surface.
3. Check/correct tyre pressure.
4. Load rear seat bench with approximately 70 kg.
5. Regulate fog lamp with adjusting screw according to upper light/dark border with adjuster.
6. The inclination of the light beam is two percent per 10 m.

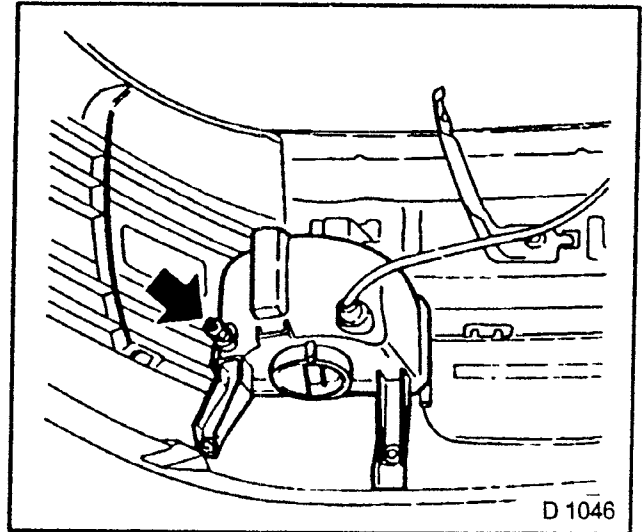


Fig 44

**Front Fog Lamp Switch — Replace****REMOVE, DISCONNECT**

1. Make removal tool out of welding rod.
2. Pull switch out of instrument panel.

**INSTALL, CONNECT**

1. Switch in instrument panel.

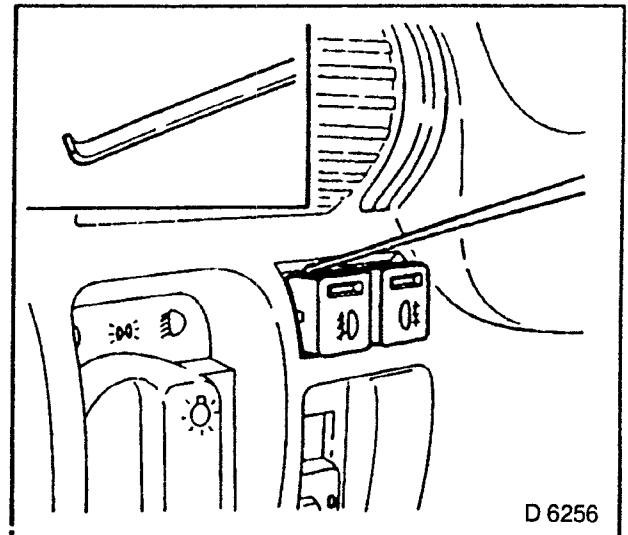


Fig. 45

**Front Fog lamp — Adjust****NOTE:**

Observe adjustment regulations in Section N.

**ADJUST**

1. Fog lamp.
2. Position vehicle on even surface.
3. Check/correct tyre pressure.
4. Load rear seat bench with approximately 70 kg.
5. Regulate fog lamp with adjusting screw according to upper light/dark border with adjuster.
6. The inclination of the light beam is two percent per 10 m.

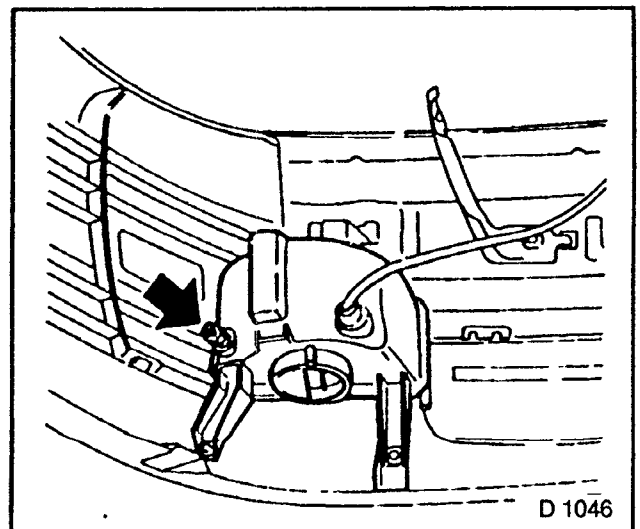


Fig. 46

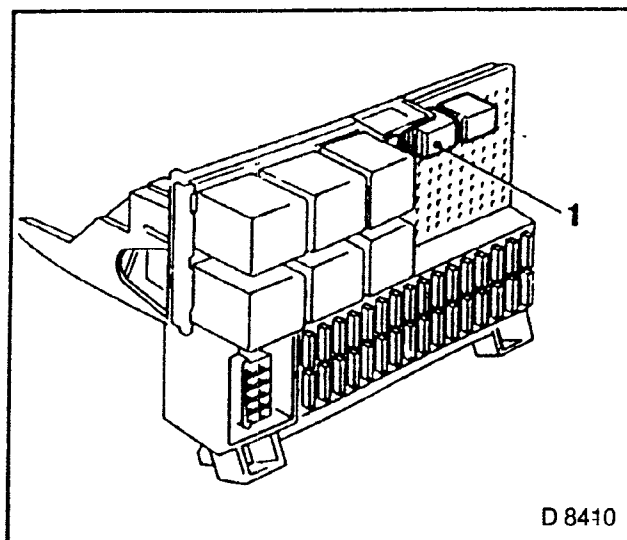
## Relay — Front Fog Lamps — Replace

### REMOVE, DISCONNECT

1. Cover from fuse box.
2. Detach fuse box.
3. Front fog lamps relay (1).

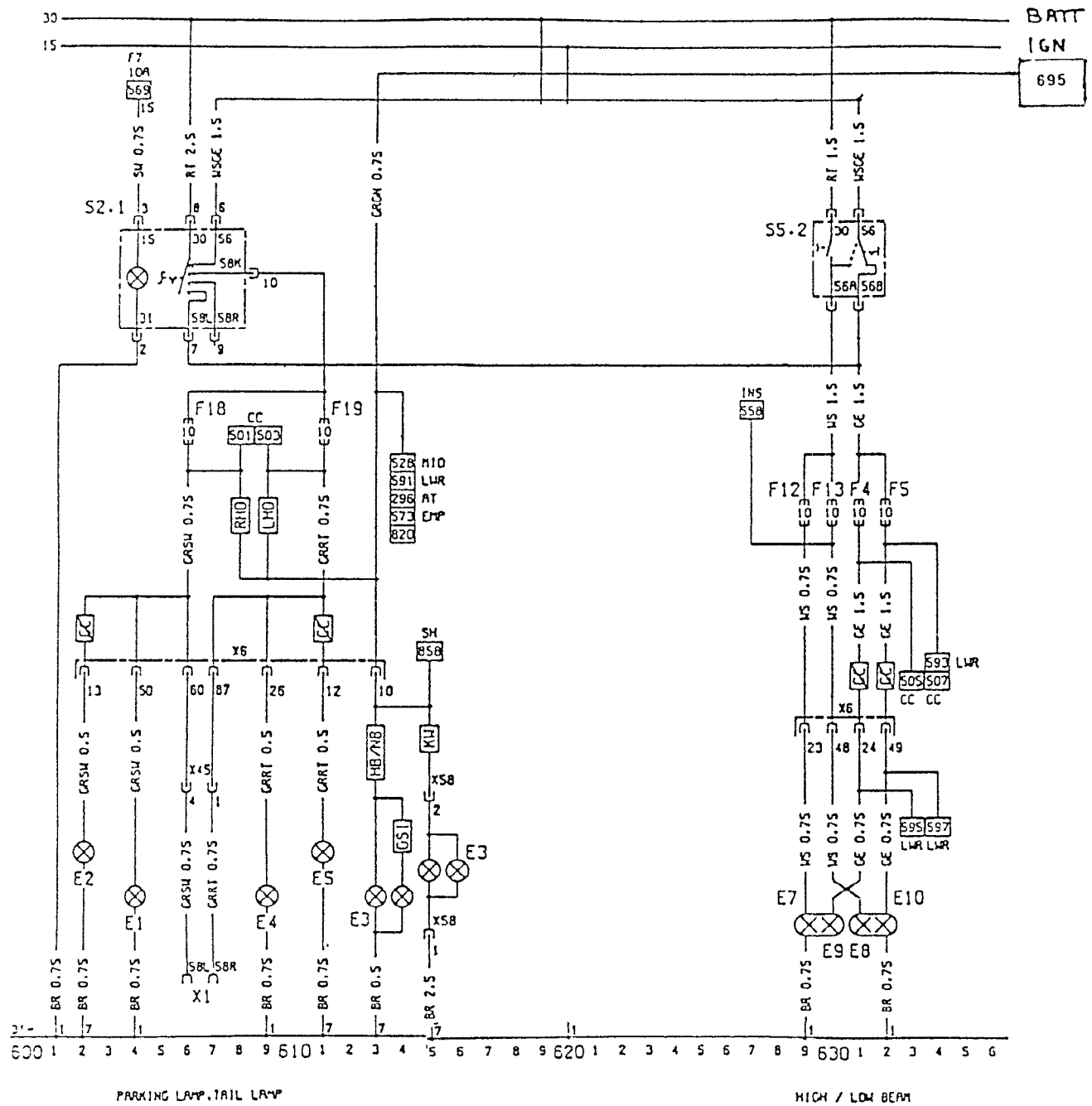
### INSTALL, CONNECT

1. Relay.
2. Fuse box.
3. Fuse box cover.



D 8410

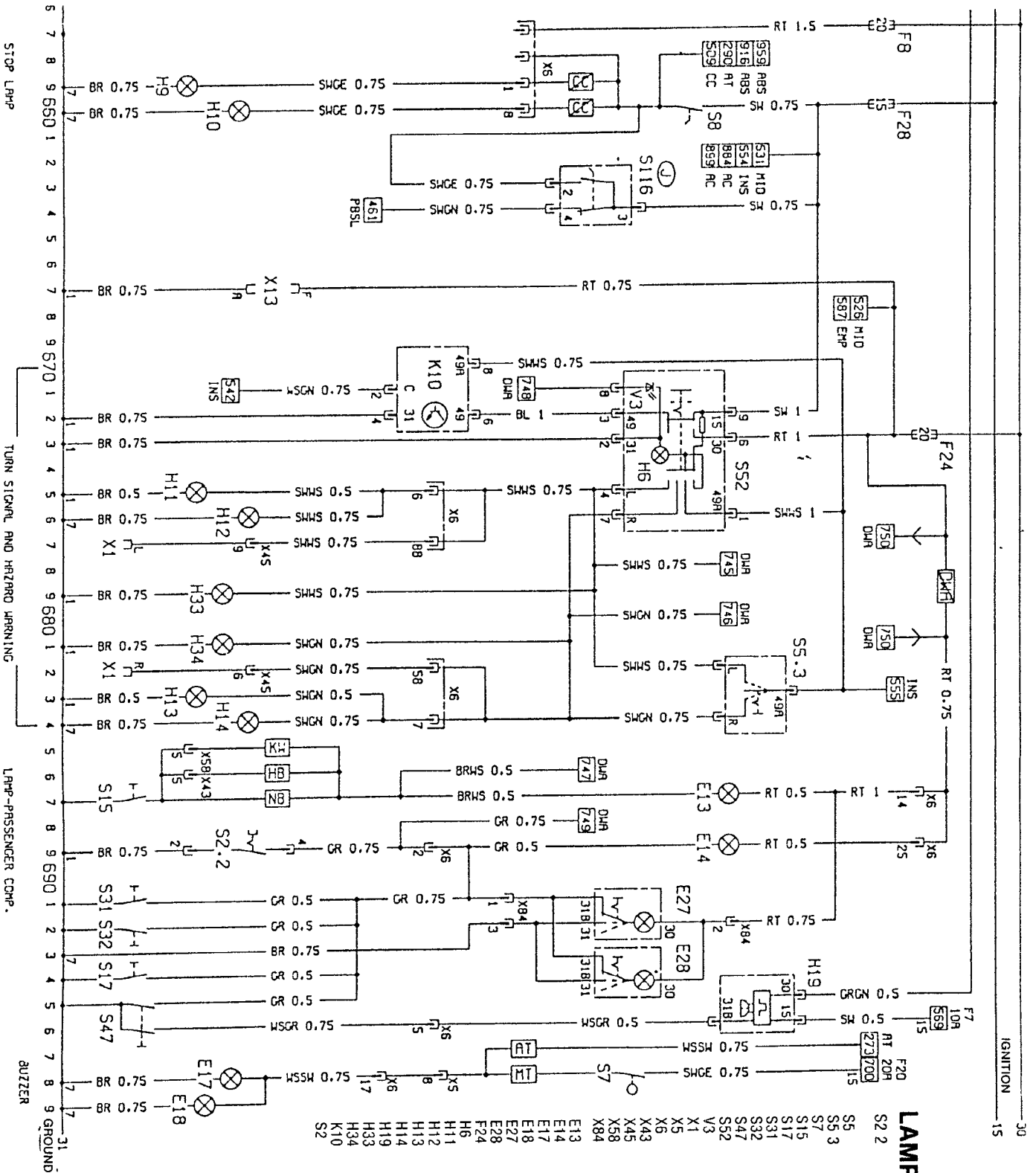
Fig. 47



SWITCH-LIGHT

LAMPS — CIRCUIT DIAGRAM

|                  |                             |                    |                   |                             |               |
|------------------|-----------------------------|--------------------|-------------------|-----------------------------|---------------|
| E1               | Parking lamp — left         | 604                | X45               | Body & Socket — Trailer SP  | 606, 607      |
| E2               | Tail lamp — left            | 602                | X58               | Body & Tail Gate 9P (KW)    | 615           |
| E3               | Lamp — Licence plate        | 613, 616           | E20               | Fog lamp — left             | 650           |
| E4               | Parking lamp — right        | 609                | E21               | Fog lamp — right            | 651           |
| E5               | Tail lamp — right           | 611                | E24               | Fog lamp — rear left — N/A  |               |
| E7               | High beam — left            | 629                | E39               | Fog lamp — rear right — N/A |               |
| E8               | High beam — right           | 631                | F8, F11, F17, F28 | Fuse                        | 657, 645, 660 |
| E9               | Low beam — left             | 630                | H9                | Stop lamp — left            | 659           |
| E10              | Low beam — right            | 632                | H10               | Stop lamp — right           | 660           |
| F4, F5, F12, F13 | Fuse                        | 631, 632           | K5                | Relay — Fog lamp            | 651 652       |
| F18 F19          | Fuse                        | 606, 611, 620      | K89               | Relay — Fog lamp, rear      |               |
| F27              |                             |                    | S8                | Switch — Stop lamp          | 660           |
| K59              | Relay — day running light   | 619, 625           | S21               | Switch — Fog lamp           | 652, 654      |
| S2               | Switch asm-light            |                    | X1                | Socket — Trailer 7P         | 677, 682      |
| S2 1             | Switch-light                | 604, 607           | X6                | Instrument panel & body 95P |               |
| S5               | Turn signal switch asm      |                    | X13               | Diagnostic link 10P         |               |
| S5 2             | Switch — low beam           | 630, 631           | X45               | Body & Socket — Trailer 9P  |               |
| X1               | Socket — Trailer 7P         | 606, 607           | X50               | Code — Fog lamp, Rear EP    |               |
| X6               | Instrument panel & body 95P | 602, 613, 629, 632 |                   |                             |               |



**LAMPS — CIRCUIT DIAGRAM**

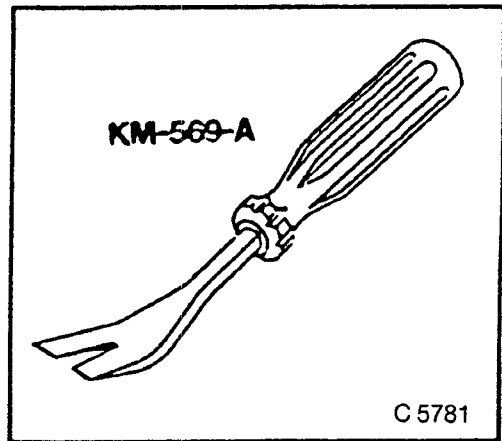
- S2 2 Switch lamp, passenger compartment 689
- S5 3 Turn signal switch ASM 682, 684
- S7 7 Switch — turn signal 698
- S7 7 Switch — Reverse lamp 687
- S15 15 Switch-lamp, trunk 694
- S17 17 Contact switch — co-driver door 691
- S31 31 Contact switch — door, rear left 692
- S32 32 Contact switch — driver door 2P 693, 696
- S47 47 Switch — hazard warning 672, 676
- S52 52 Switch — hazard warning 671
- V3 3 Light Diode anti-theft warning unit 677, 682
- X1 1 Socket — Trailer 7P 698
- X5 5 Instrument panel & engine 30P 698
- X6 6 Instrument panel & boot 95P 686
- X43 43 Boot & Tailgate 5P H8 677, 682
- X45 45 Boot & socket — Trailer 9P 685
- X58 58 Boot & Tail gate 9P (KW) 691, 692
- X84 84 Boot & Reading lamps, rear 4P, 687
- E13 13 Lamp — Trunk 689
- E14 14 Lamp — Passenger Compartment 698
- E17 17 Reverse lamp — left 699
- E18 18 Reverse lamp — right 692
- E27 27 Reading lamps, rear — left 694
- E28 28 Reading lamps, rear — right 673
- F24 24 Fuse 674
- H6 6 Telltale-hazard warning system 675
- H11 11 Turn signal lamp — front left 676
- H12 12 Turn signal lamp — rear left 683
- H13 13 Turn signal lamp — front right 684
- H14 14 Turn signal lamp — rear right 695, 696
- H19 19 Warning buzzer — Headlamps on Auxiliary turn signal lamp — left 679
- H33 33 Auxiliary turn signal lamp — left 681
- H34 34 Auxiliary turn signal lamp — right 670, 672
- K10 10 Flasher unit 687
- K11 11 Switch ASM-light 688

IGNITION 15  
30


## SPECIAL SERVICE TOOLS

### KM-569-A — PLUG EXTRACTOR

To remove fastening plugs on inner panelling.





**Opel Astra**  **Opel Kadett**

## **Workshop Manual**

### **Section N**

# **Electrical Equipment and Instruments**

Issued by: Service Division  
Delta Motor Corporation  
July, 1993

# Index

|   | Page |
|---|------|
| <b>WIRING HARNESS, FUSE BOX</b>                             |      |
| SURVEY OF FUSE BOX — FUSE BOX WITH 28 FUSES .....           | N-6  |
| SURVEY OF FUSES AND RELAYS IN ENGINE COMPARTMENT .....      | N-7  |
| SURVEY OF RELAYS/CONTROL UNITS .....                        | N-3  |
| WIRING HARNESS — FRONT AND REAR DOORS .....                 | N-8  |
| WIRING HARNESS, DOORS .....                                 | N-9  |
| WIRING HARNESS, ENGINE .....                                | N-15 |
| WIRING HARNESS, FRONT BODY .....                            | N-16 |
| WIRING HARNESS, INSTRUMENT PANEL .....                      | N-14 |
| WIRING HARNESS, LUGGAGE COMPARTMENT LID — (ASTRA) ..        | N-13 |
| WIRING HARNESS, REAR BODY — (KADETT) .....                  | N-10 |
| WIRING HARNESS, REAR BODY — (ASTRA) .....                   | N-12 |
| WIRING HARNESS, TAILGATE — (KADETT) .....                   | N-11 |
| <b>HEADLAMPS, EXTERIOR LAMPS, INTERIOR LAMPS, SWITCHES</b>  |      |
| BRAKE LAMP SWITCH, REMOVE AND INSTALL .....                 | N-28 |
| BULB — INTERIOR LAMP, REPLACE .....                         | N-23 |
| BULB — LICENSE PLATE LAMP, REPLACE .....                    | N-23 |
| BULB — REAR LAMP, REPLACE — (KADETT) .....                  | N-22 |
| BULB — REAR LAMP, REPLACE — (ASTRA) .....                   | N-21 |
| BULB — REAR READING LAMP, REPLACE .....                     | N-24 |
| BULB — SIDE TURN SIGNAL LAMP, REPLACE .....                 | N-21 |
| BULB — TURN SIGNAL LAMP, FRONT, REPLACE .....               | N-20 |
| HAZARD WARNING LAMP SWITCH, REMOVE AND INSTALL .....        | N-27 |
| HEADLAMP ADJUSTMENT, CHECK AND ADJUST .....                 | N-17 |
| HEADLAMP REMOVE AND INSTALL .....                           | N-25 |
| HEADLAMPS WITH HEADLAMP RANGE CONTROL, REPLACE .....        | N-25 |
| HORN, REMOVE AND INSTALL .....                              | N-29 |
| INTERIOR LAMP, REMOVE AND INSTALL .....                     | N-23 |
| LIGHT AND INTERIOR LAMP SWITCH, REMOVE AND INSTALL .....    | N-26 |
| LICENSE PLATE LAMP, REMOVE AND INSTALL .....                | N-22 |
| PARKING BRAKE TELLTALE SWITCH, REMOVE AND INSTALL ..        | N-28 |
| REAR LAMP, REMOVE AND INSTALL (KADETT) .....                | N-22 |
| REAR LAMP, REMOVE AND INSTALL (ASTRA) .....                 | N-21 |
| REAR READING LAMP, REMOVE AND INSTALL .....                 | N-24 |
| SIDE TURN SIGNAL LAMP, REMOVE AND INSTALL .....             | N-20 |
| SIGNAL SWITCH COVER, REMOVE AND INSTALL .....               | N-29 |
| SIGNAL SWITCH, REMOVE AND INSTALL .....                     | N-27 |
| FOG LAMP SWITCH, REMOVE AND INSTALL .....                   | N-29 |
| TURN SIGNAL LAMP, FRONT, REMOVE AND INSTALL .....           | N-20 |
| TURN SIGNAL/WIPER SWITCH, REMOVE AND INSTALL .....          | N-26 |
| <b>STEERING AND IGNITION LOCK</b>                           |      |
| CONTACT PIECE FOR STEERING AND IGNITION LOCK, REPLACE ..... | N-30 |
| LOCK CYLINDER FOR STEERING AND IGNITION LOCK, REPLACE ..... | N-31 |
| <b>INSTRUMENTS</b>  |      |
| INSTRUMENT ASSEMBLY, REMOVE AND INSTALL .....               | N-32 |
| INSTRUMENT HOUSING COVER, REMOVE AND INSTALL .....          | N-32 |
| INSTRUMENT/TELLTALES, REPLACE .....                         | N-35 |
| PRINTED CIRCUIT BOARD, REMOVE AND INSTALL .....             | N-35 |
| SPEEDOMETER REMOVE AND INSTALL .....                        | N-34 |
| TACHOMETER, REMOVE AND INSTALL .....                        | N-36 |
| TEMPERATURE GAUGE, FUEL GAUGE, REMOVE AND INSTALL .....     | N-33 |
| VOLTAGE STABILIZER, REMOVE AND INSTALL .....                | N-34 |

## **CENTRAL DOOR LOCKING**

|   |      |
|---|------|
| CONTROL UNIT, REMOVE AND INSTALL .....                                    | N-39 |
| SERVO MOTOR (FRONT DOOR), REMOVE AND INSTALL .....                        | N-40 |
| SERVO MOTOR (FUEL FILLER FLAP), REMOVE AND INSTALL — (KADETT) .....       | N-40 |
| SERVO MOTOR (FUEL FILLER FLAP), REMOVE AND INSTALL — (ASTRA) .....        | N-41 |
| SERVO MOTOR (LUGGAGE COMPARTMENT LID), REMOVE AND INSTALL — (ASTRA) ..... | N-41 |
| SERVO MOTOR (REAR DOOR), REMOVE AND INSTALL .....                         | N-40 |
| SERVO MOTOR (TAILGATE), REMOVE AND INSTALL .....                          | N-41 |
| SERVO MOTOR — DRIVER'S DOOR, ADJUST .....                                 | N-37 |
| SERVO MOTOR — PASSENGER DOOR, ADJUST .....                                | N-38 |
| SERVO MOTOR — REAR DOORS, ADJUST .....                                    | N-39 |
| SWITCH (DRIVER'S DOOR), REMOVE AND INSTALL .....                          | N-42 |

## **DISPLAY SYSTEMS**

|  |      |
|--|------|
| CLEANING FLUID RESIDUE SENSOR, REPLACE ..... | N-44 |
| COOLANT RESIDUE SENSOR, REPLACE .....        | N-43 |
| ENGINE OIL RESIDUE SENSOR, REPLACE .....     | N-44 |
| FUNCTION DISPLAY, REMOVE AND INSTALL .....   | N-43 |
| OUTSIDE TEMPERATURE SENSOR, REPLACE .....    | N-44 |

## **HEATED REAR SCREEN**

|   |      |
|---|------|
| HEATED REAR SCREEN RELAY, REPLACE .....             | N-45 |
| HEATED REAR SCREEN SWITCH, REMOVE AND INSTALL ..... | N-45 |

## **SCREEN WIPERS, SCREEN WASH/WIPE SYSTEM**

|   |      |
|---|------|
| INTERVAL RELAY — SCREEN WASH/WIPE SYSTEM, REPLACE .....       | N-47 |
| PUMP — SCREEN WASH/WIPE SYSTEM, REMOVE AND INSTALL .....      | N-47 |
| REAR SCREEN WIPER MOTOR, REMOVE AND INSTALL — (KADETT) .....  | N-46 |
| WASH/WIPE SYSTEM RESERVOIR, REMOVE AND INSTALL .....          | N-47 |
| WINDSCREEN WIPER MOTOR WITH LINKAGE, REMOVE AND INSTALL ..... | N-46 |

## **ELECTRONICALLY OPERATED WINDOW WINDERS**

|   |      |
|---|------|
| OPERATING SWITCH (DRIVER'S DOOR), REMOVE AND INSTALL .....  | N-48 |
| OPERATING SWITCH (PASSENGER DOOR), REMOVE AND INSTALL ..... | N-48 |

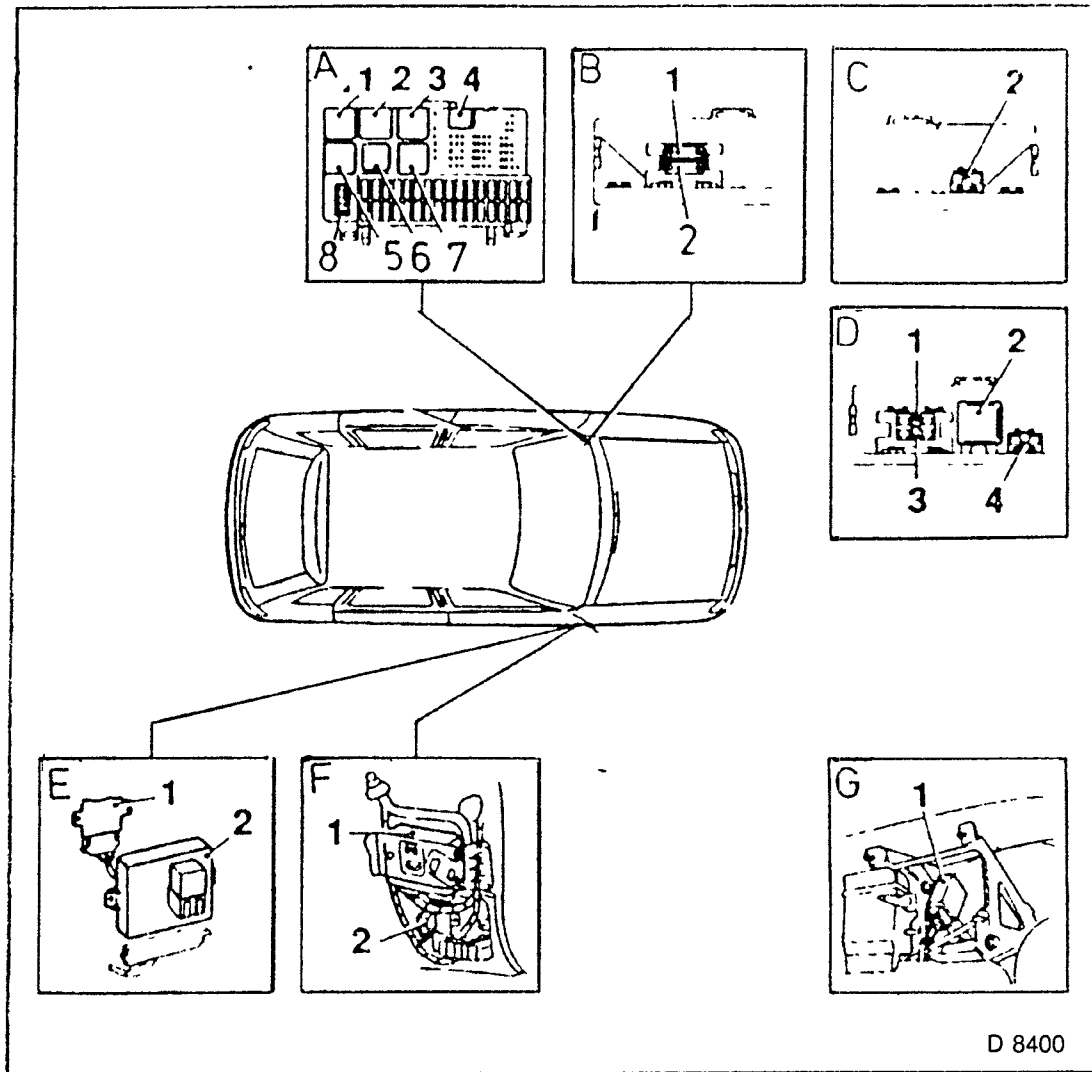


Fig 1

## Wiring Harness, Fuse Box

### SURVEY OF RELAYS/CONTROL UNITS

#### A Fuse box

- 1 — Relay, heated outer mirror K35
- 2 — Relay, turn signal unit/trailer hitch turn signal unit K10
- 3 — Relay, rear screen wash/wipe system K30
- 4 — Relay, fog lamp K5
- 5 — Relay, windscreen wash/wipe system K8
- 6 — Relay, heated rear screen K1
- 7 — Warning buzzer H19
- 8 — Diagnostic plug

#### B Fuse box, rear view

- 1 — Fuse 30A, radiator fan F42
- 2 — Fuse 30A, heating fan F46

#### C Fuse box, rear view

- 1 — Fuse 10A, anti-theft warning system F38

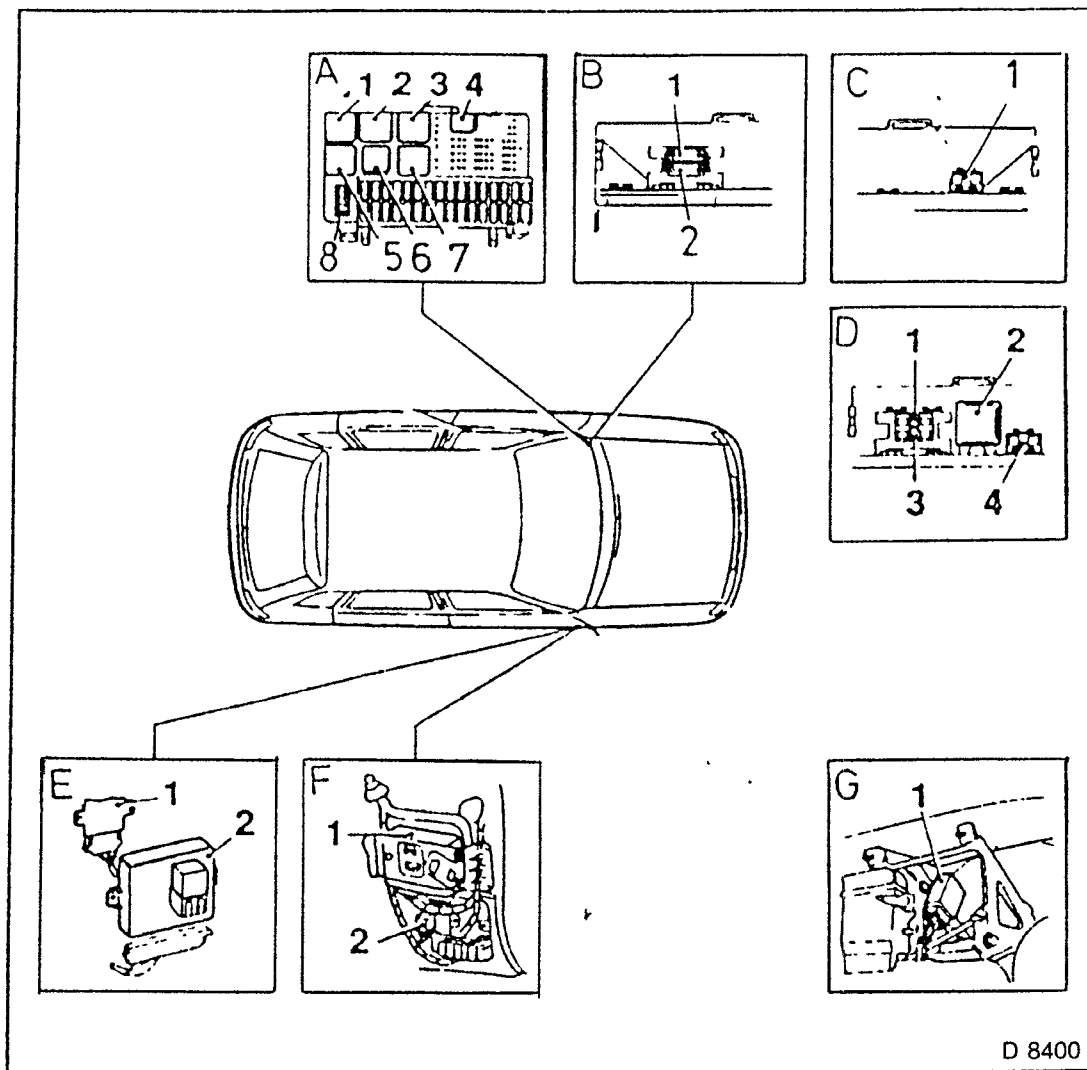


Fig 2

**D Fuse box, rear view**

- 1 — Fuse 30A radiator fan F42
- 2 — Relay, starter K3
- 3 — Fuse 30A heater fan F46
- 4 — Fuse 10A anti-theft warning system F38

**E A pillar, right**

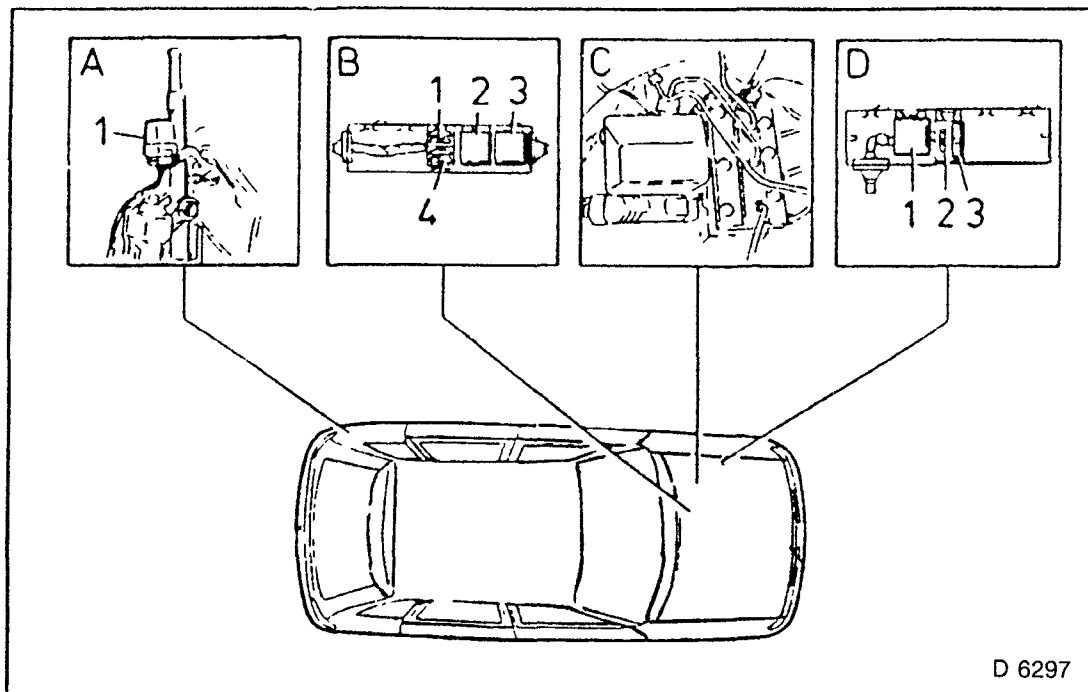
- 1 — Control unit central door locking K37
- 2 — Control unit anti-theft warning system K94

**F A pillar, right**

- 1 — Control unit, Motronic/MPFI/TBI/preheating time
- 2 — Relay, fuel pump K58/K68

**G Bracket, steering column**

- 1 — Relay, driving lamp K59 (only Sweden/Norway)



D 6297

Fig 3

**A Rear quarter panel, left**

- 1 — Automatic antenna relay

**B On bulkhead**

- 1 — Fuse 30A, headlamp high pressure wash/wipe system F39
- 2 — Relay, headlamp high pressure wash/wipe system K97
- 3 — Relay, fanfare K63
- 4 — Fuse, fanfare F45

**C Hydraulic modulator**

- 1 — Control unit, ABS

**D On engine compartment wheel well, left TC 4EE1**

- 1 — Fuel pre-heating relay K80 (green)
- 2 — Fuse 30A, fuel pre-heating F36 (green)
- 3 — Fuse 60A, preheating time F41 (black)

## Survey of Fuse Box — Fuse Box with 28 Fuses

1. 20A Central Locking System \*
  2. 20A Fuel Pump
  3. 30A Windshield Wipers, Horn
  4. 10A Dipped Beam (Left)
  5. 10A Dipped Beam (Right)
  6. 20A ABS\*, Automatic Transmission \*
  7. 10A Electrically adjustable exterior mirror\*, Lamp Glove Box, Control indicators
  8. — Not applicable
  9. — Not applicable
  10. 30A Electrically Operated door windows\*
  11. — Not applicable
  12. 10A Main Beam (Left)
  13. 10A Main Beam (Right)
  14. 30A Heater Fan, Air Conditioning System
  15. 30A Cooling Fan
  16. 30A Heated Rear Window
  17. 20A Fog Lamps\*
  18. 10A Parking and Tail Lamps (Left)
  19. 10A Parking and Tail Lamps (Right)  
Instrument Illumination, Licence Plate Lamp
  20. 20A Carburettor preheating\*, reverse lamp, cigarette lighter
  21. 30A Cooling Fan, Air conditioning system
  22. — Not Applicable
  23. 30A Blower Heater Fan (without Air Con.)
  24. 20A Courtesy Lamp, Luggage Compartment Lamp, Hazard Warning flashers, clock, radio\*, trip computer\*
  25. 10A Automatic Transmission\*
  26. — Not applicable
  27. — Not applicable
  28. 15A Turn signal lamps, brake lamps, ABS\*
- At rear of fuse box:  
10A Vehicle Security System horn\*

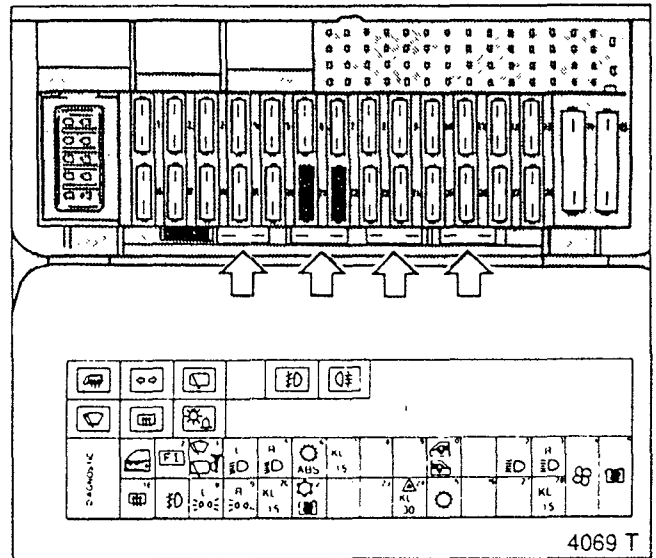


Fig 4

## Survey of Fuses and Relays in Engine Compartment

### ON BULKHEAD

- 1 — Relay, fanfare K63 (black)
- 2 — Fuse 20A, fanfare F45

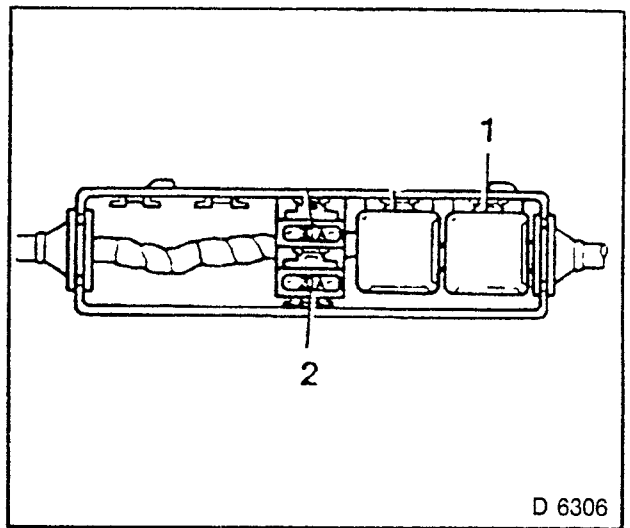


Fig 5

### ON ENGINE COMPARTMENT WHEEL HOUSING, LEFT TC 4EE1 (Fig. 6 "A")

- 1 — Relay, fuel pre-heating K80 (green)
- 2 — Fuse 30A, fuel pre-heating F36 (green)
- 3 — Fuse 60A, glow plugs F41 (black)

### ON ENGINE COMPARTMENT WHEEL HOUSING, LEFT 17D (Fig. 6 "B")

- 1 — Fuel pre-heating relay K80 (green)
- 2 — Fuse A30, fuel pre-heating F36 (green)
- 3 — Engine cold start acceleration relay K82 (black)

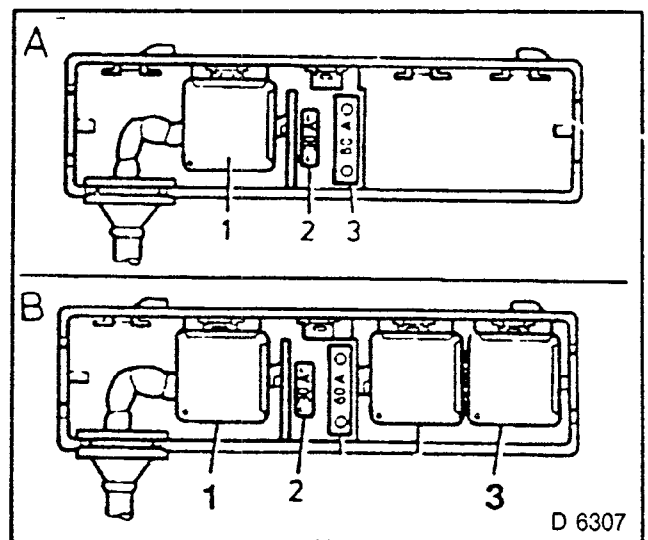


Fig. 6



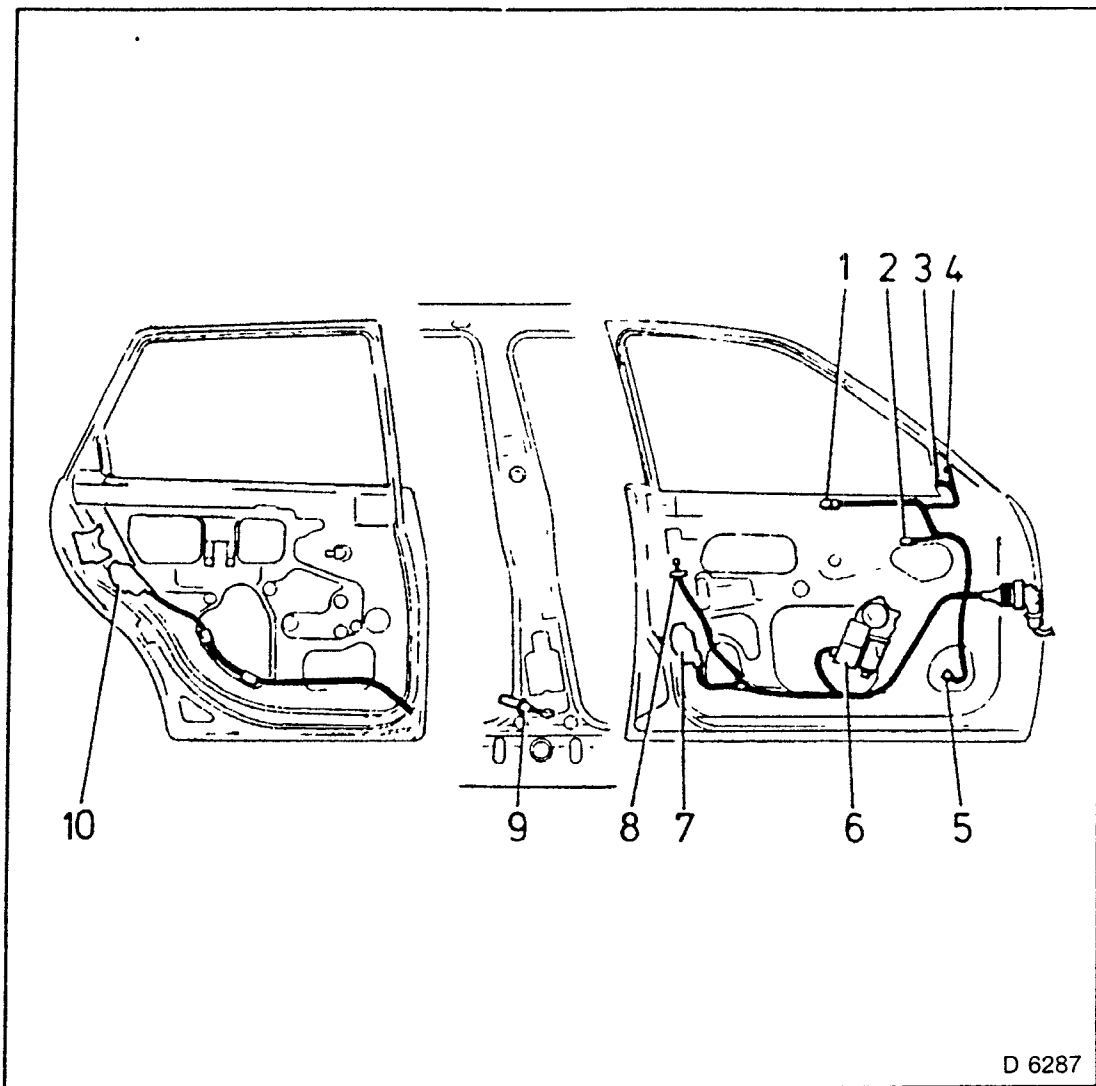


Fig. 7

## Wiring Harness Front and Rear Doors

- 1 — To switch, electrical mirror adjustment
- 2 — To switch, electrical window winder
- 3 — Plug, electrical mirror adjustment
- 4 — To treble loudspeaker
- 5 — To bass loudspeaker
- 6 — Window winder motor
- 7 — Central door locking motor
- 8 — Central door locking switch
- 9 — Rear door wiring harness plug
- 10 — Central door locking motor

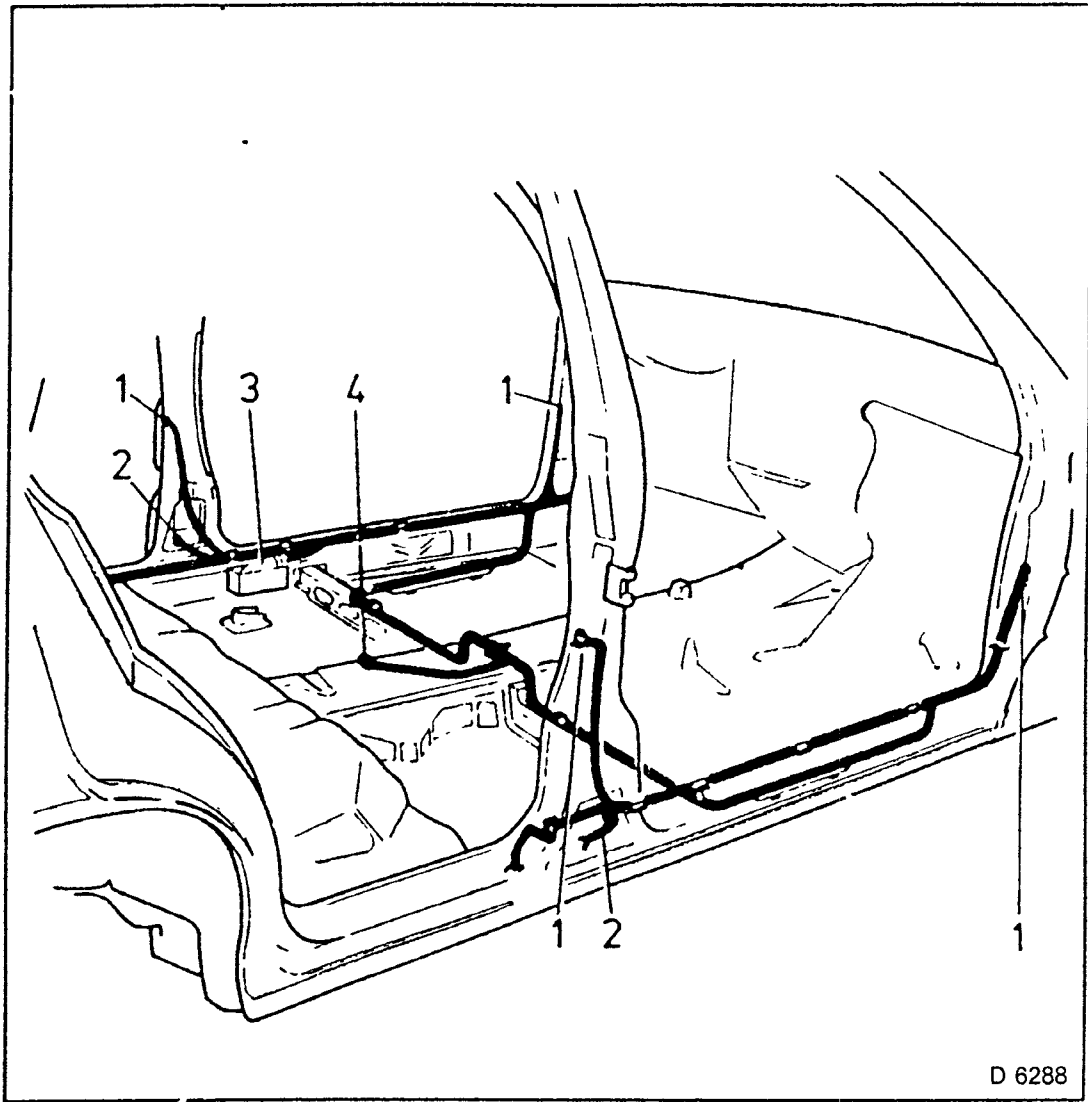
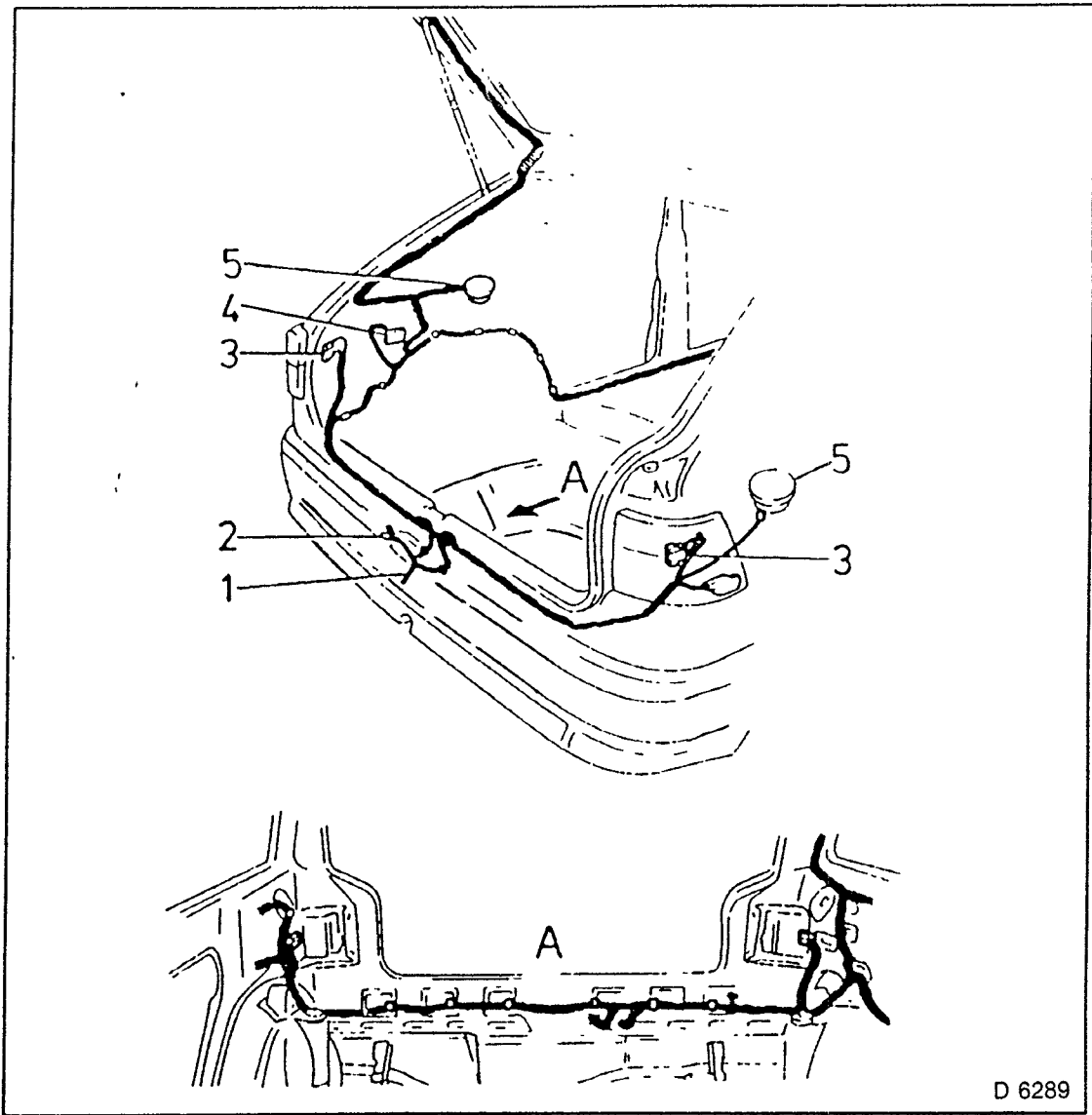


Fig 8

### Wiring Harness, Doors

- 1 — Interior lamp contact switch
- 2 — Connection to rear doors wiring harness
- 3 — ETC control unit
- 4 — Parking brake telltale switch



D 6289

Fig. 9

### Wiring Harness, Rear Body (Kadett)

- 1 — Trailer hitch connection
- 2 — Licence plate lamp connection
- 3 — Rear lamp connection
- 4 — Luggage compartment lamp
- 5 — Loudspeaker connection

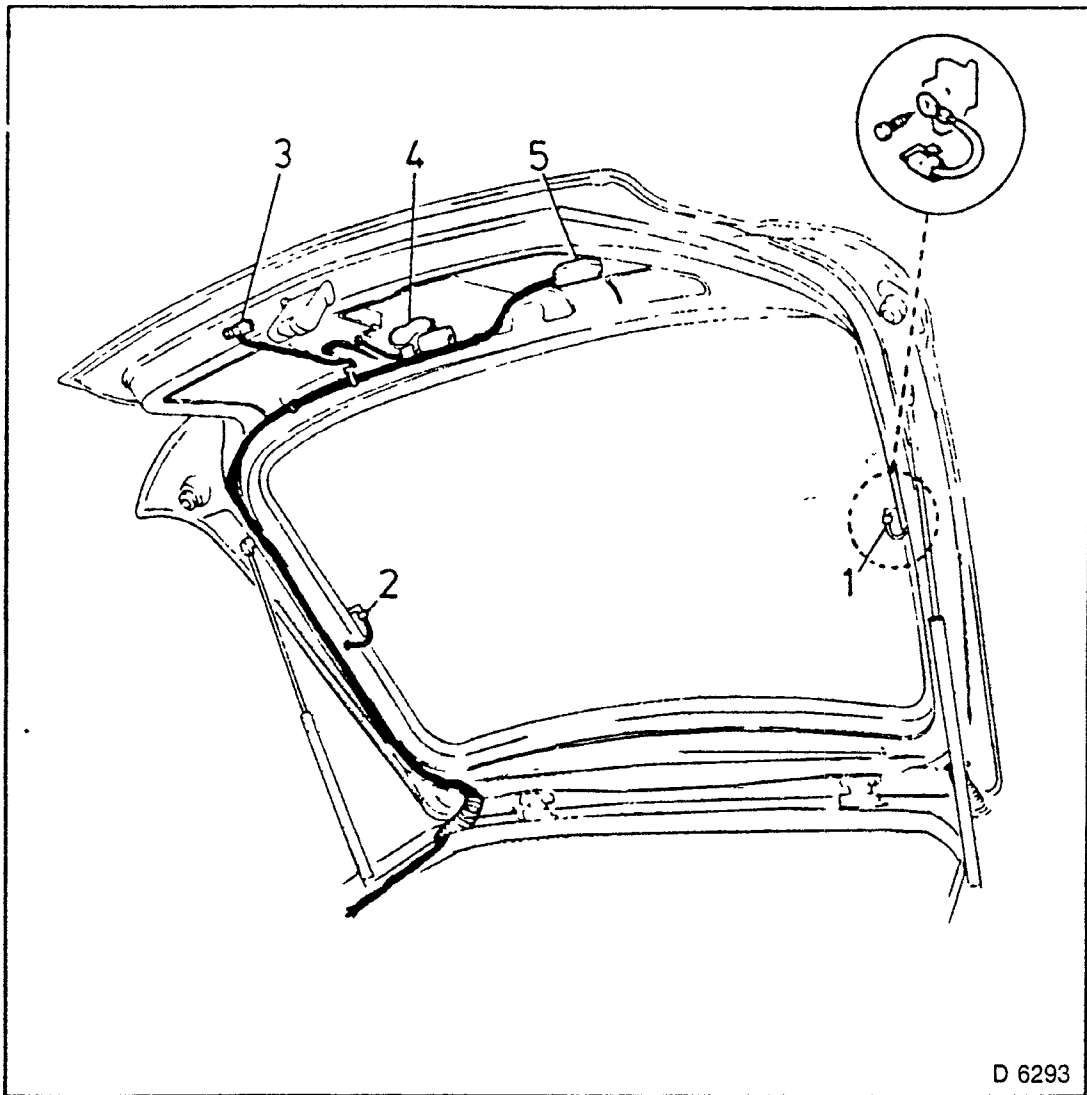


Fig. 10

### Wiring Harness, Tailgate (Kadett)

- 1 — Heated rear screen ground connection
- 2 — Heated rear screen current connection
- 3 — Luggage compartment lamp switch
- 4 — Windscreen wiper motor
- 5 — Central door locking motor

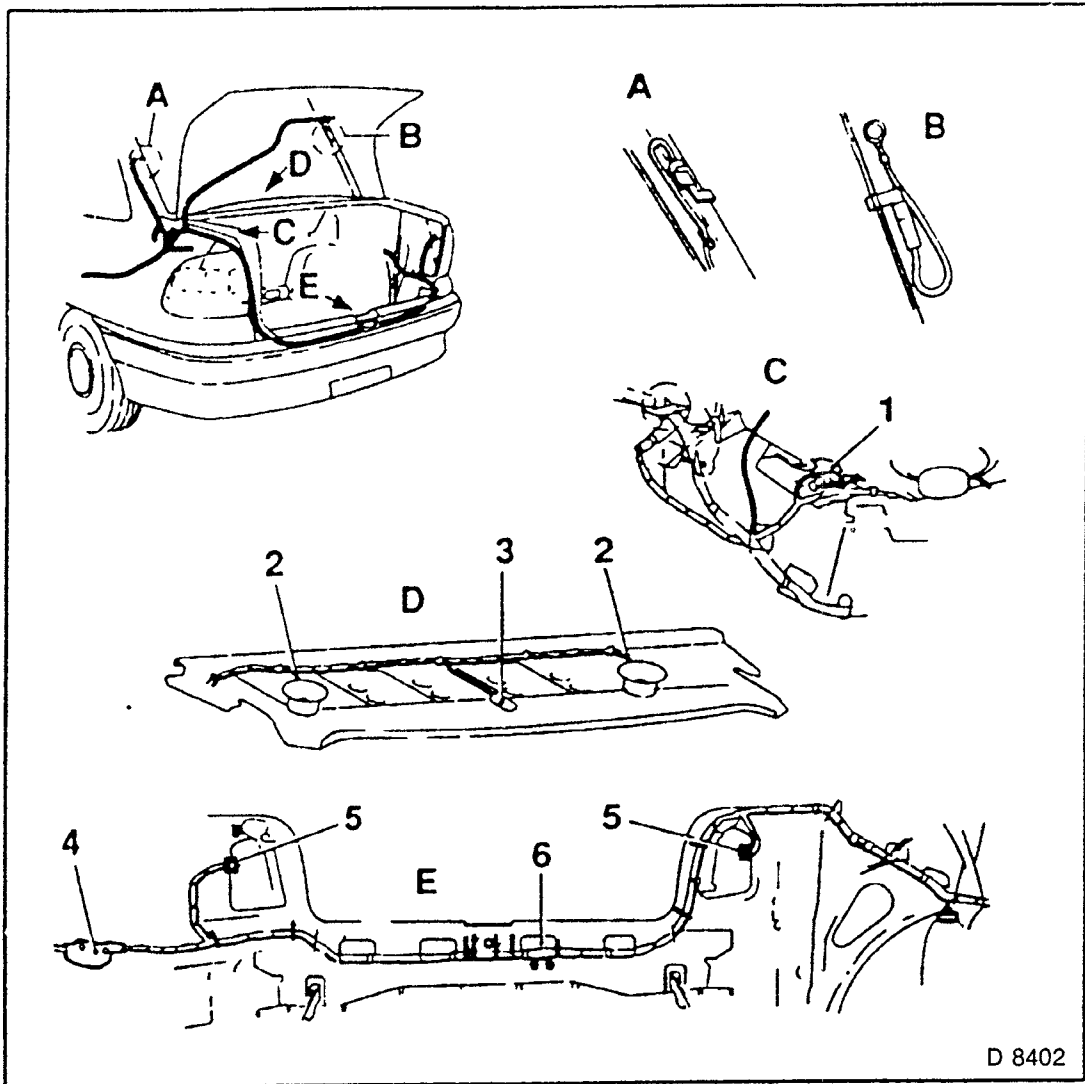


Fig 11

## Wiring Harness, Body, Rear (Astra)

### A — LEFT C PILLAR

Positive connection, heated rear screen

### B — RIGHT C PILLAR

Ground connection, heated rear screen

### C — LUGGAGE COMPARTMENT, TOP LEFT

1 — Switch for luggage compartment illumination

### D — UPPER REAR END PANEL

2 — Loudspeakers

3 — Luggage compartment lamp

### E — LOWER REAR END PANEL

4 — Central door locking servo motor for fuel tank flap

5 — Rear lamps connection

6 — License plate lamp connection trailer hitch

D 8402

## Wiring Harness, Luggage Compartment Lid — (Astra)

- 1 — Motor for central door locking
- 2 — Switch for central door locking

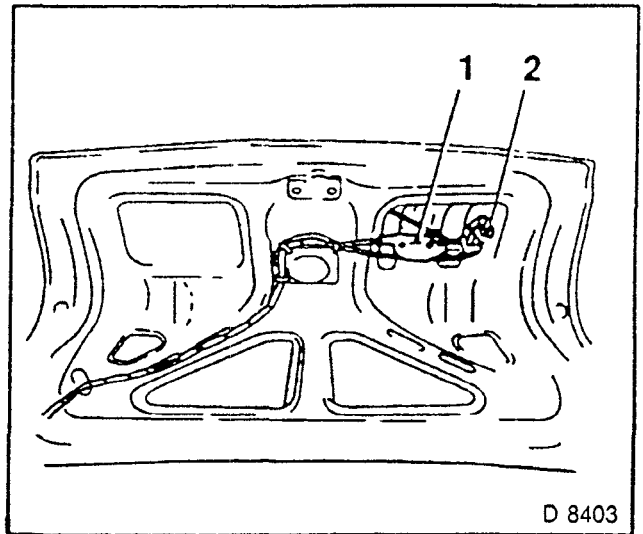
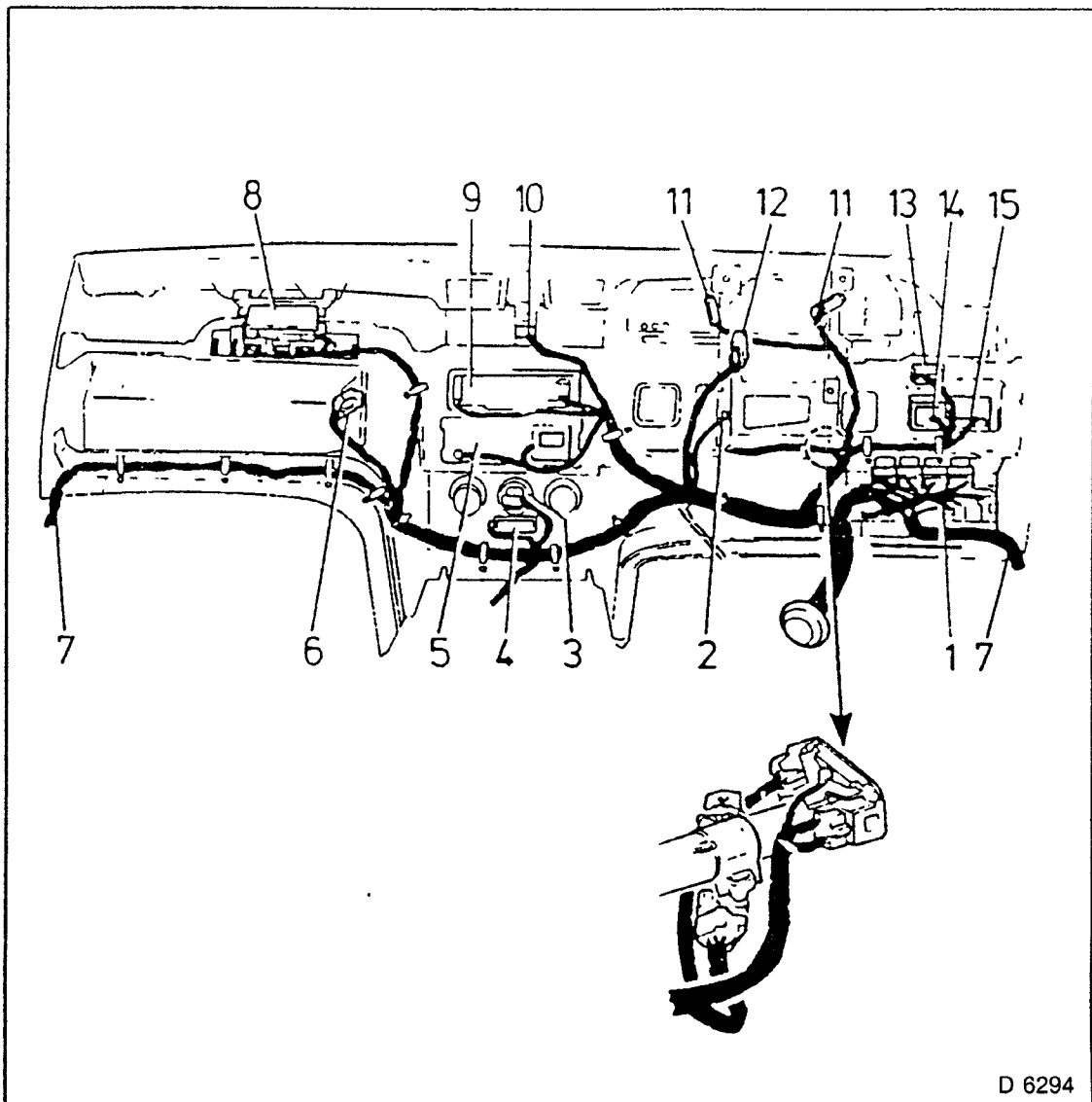


Fig 12



D 6294

Fig 13

## Wiring Harness, Instrument Panel

- |                                   |   |
|-----------------------------------|---|
| 1 — Central electrics             | 9 — Display: MID/DID                            |
| 2 — Ground connection             | 10 — Hazard warning lamp switch                 |
| 3 — Fan/heated rear screen switch | 11 — Instrument assembly connection             |
| 4 — Recirculating air switch      | 12 — Driving lamp relay<br>(only Sweden/Norway) |
| 5 — Radio                         | 13 — Rear fog lamp/fog lamp switch              |
| 6 — Glove compartment lamp        | 14 — Headlamp range control switch              |
| 7 — To body wiring harness        | 15 — Light and interior lamp switch             |
| 8 — Bulb monitor sensor           |   |

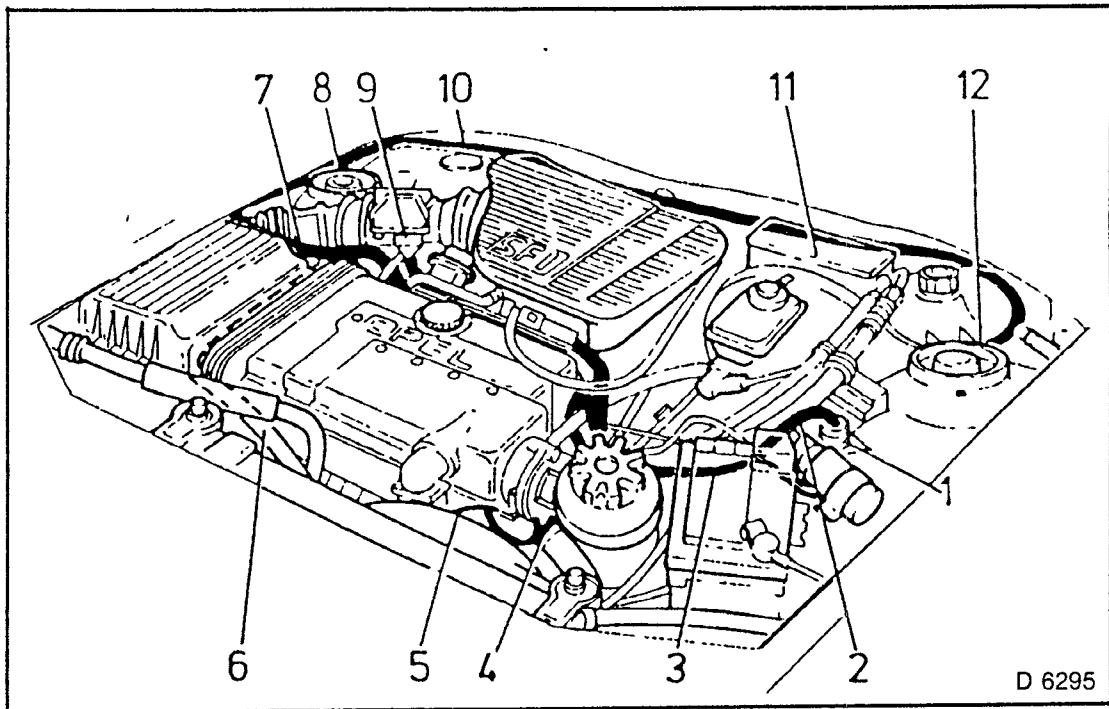


Fig 14

D 6295

## Wiring Harness, Engine

### WIRING HARNESS C20 XE ENGINE

- 1 — To instrument panel wiring harness
- 2 — Ignition coil
- 3 — Reversing lamps switch
- 4 — Hall sensor, cylinder recognition
- 5 — Remaining oil amount sensor
- 6 — Coolant temperature sensor
- 7 — To crankshaft pulse pick up wiring harness
- 8 — To body wiring harness
- 9 — To mass air flow sensor
- 10 — Oxygen sensor wiring plug
- 11 — Relays/fuses
- 12 — Octane number adjustment



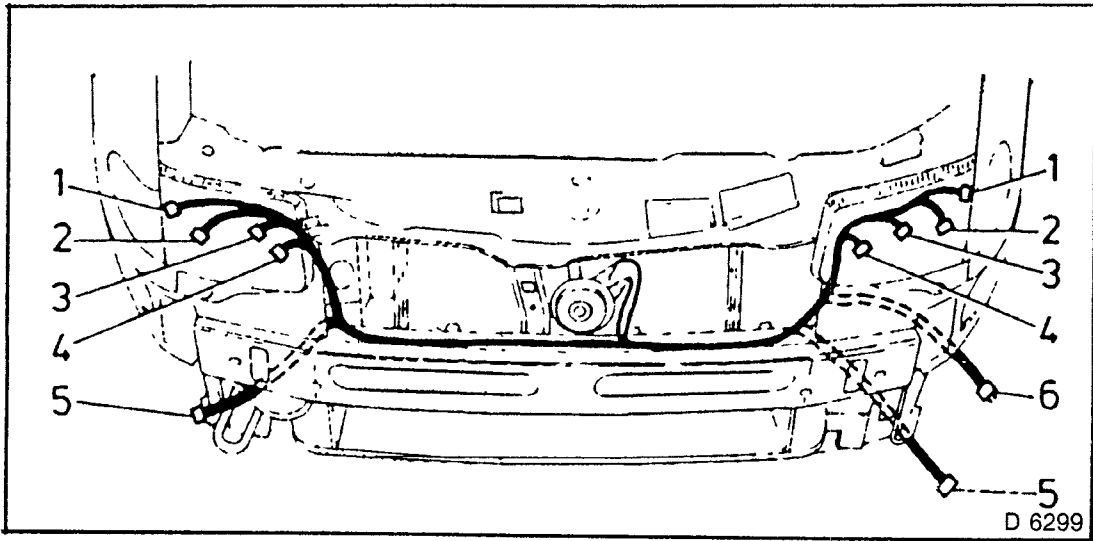


Fig. 15

## Wiring Harness, Front Body

- 1 — Connection, turn signal unit
- 2 — Connection, headlamp range control
- 3 — Connection, low beam/high beam
- 4 — Connection, parking light
- 5 — Connection, fog lamp
- 6 — Connection, outside temperature

# Headlamps, exterior lamps, interior lamps, switch

## HEADLAMP ADJUSTMENT, CHECK AND ADJUST

The main headlamp housing or retainer displays the reference  $\equiv \triangleright 1,2\%$  for the low beam adjustment according to EEC 76/756 or ECE — R48 guidelines. The fog lamp has not yet been provided with a reference for the 2% inclination of the light beam centre.

The 76/756 EEC or ECE — R48 guidelines cover checking and adjustment of headlamps on the vehicle. The correct adjustment of the headlamps on the vehicle should enable optimal road illumination by the low beam, with minimal dazzling of oncoming traffic. The inclination of the headlamp beam to the level road surface and the angle of the beam to the vertical longitudinal plane running through the vehicle's centre must satisfy the conditions laid down in the guidelines.

Dazzling (low beam) is considered eliminated if the intensity of illumination at a distance of 25 m from each individual headlamp on the plane perpendicular to the road and at the height of the headlamp as well as beyond, is not greater than 1 lux. This requirement is generally satisfied if the headlamp adjustment is carried out according to the adjustment guidelines.

The reference  $\equiv \triangleright 1,2\%$  corresponds to the adjustment dimension of the headlamp in reference to the inclination of the light beam. The inclination at 10 m distance from the vehicle headlamp is therefore 12 cm (Fig. 16 and Fig. 17).

The inclination of low beam headlamp is indicated by its light/dark border.

The headlamps are adjusted with an adjustment unit according to the specifications, as shown in Figs. 16 and 17. When a headlamp adjustment unit is used, the surfaces where the vehicle is standing and where the unit is set up must be flat and parallel to one another.

The vehicle tyres must be inflated to the prescribed pressures. Defective headlamp lenses and mirrors and blackened bulbs must be replaced before adjustment.

Adjustment is made with vehicle at curb weight, laden with one person or 75 kg on the driver's seat. (Curb weight = weight of vehicle ready for operation with fuel tank completely full and including the weight of all accessories normally carried, e.g. spare wheel, tools, jack, fire extinguisher, first aid kit, warning triangle, etc.)

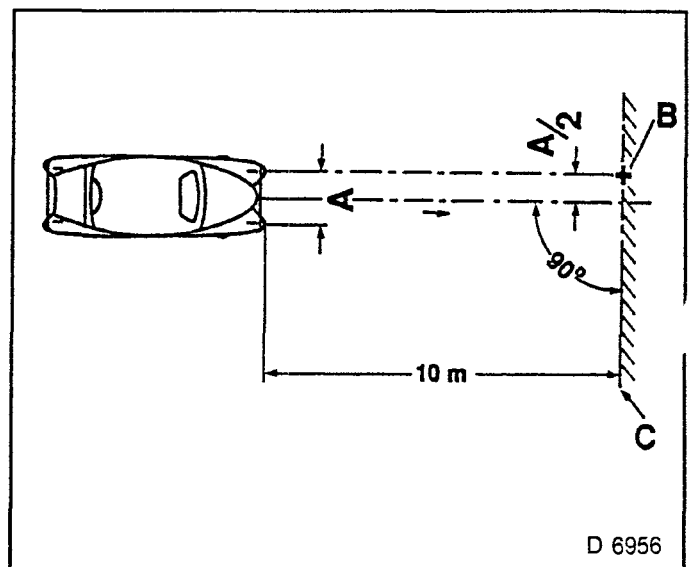


Fig. 16

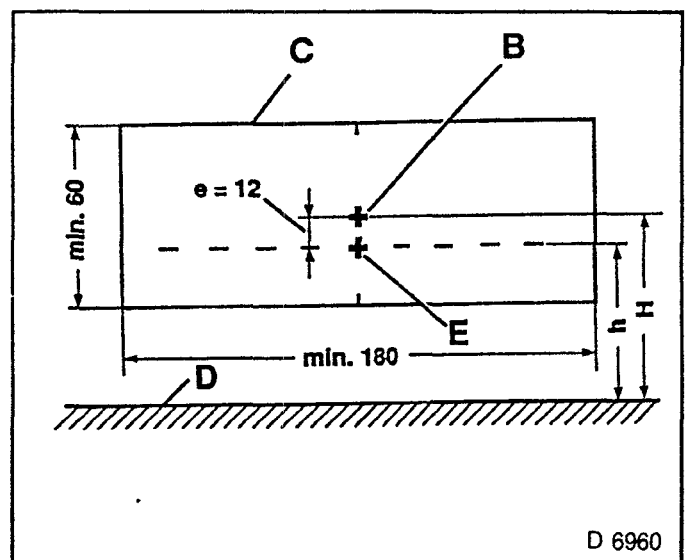


Fig. 17

- A = Horizontal distance between centre points of headlamps
- B = Central marking
- C = Test surface
- D = Road surface
- E = Point of deflection
- e = Adjustment dimension in cm;  $e = H - h$  (adjustment of headlamps 1,2%,  $e = 12$  cm, fog lamps 2%,  $e = 20$ cm)
- H = Height of centre of headlamp over road surface
- h = Height of light/dark border of low beam headlamp above road surface

The headlamp adjustment is carried out according to the regulations, as shown in Fig. 5, 18 and 19, using an adjuster. When using a headlamp adjuster, ensure that the vehicle road surface and surface for setting up the adjuster are level and parallel to one another.

Vehicle tyres must have the prescribed air pressure. Defective headlamp lenses and mirrors as well as blackened bulbs must be replaced before adjusting.

Adjustment is carried out at vehicle curb weight plus one person or 75 kg on the driver's seat (Curb weight = weight of operation — ready vehicle with completely filled fuel tank as well as weight of all equipment carried during operation, e.g. spare wheel, tools, jack, first aid kit, emergency warning triangle, etc.)

Vehicles with manual level control must be adjusted to the prescribed basic pressure (0,8 bar at curb weight). On vehicles with automatic level control, switch on ignition so that the automatic level control brings the vehicle (curb weight) to normal position. After approximately one minute, the headlamp adjustment can be made.

On vehicles with headlamp range control, the switch for headlamp range control must be at position "O" (position for headlamp basic adjustment).

The intersection between the horizontal and the ascending parts of the light/dark border (break point) must lie on the perpendicular through the central marking.

For easier determination of the intersection point, the headlamp halves can be alternately covered and uncovered a few times.

The headlamp adjuster used must correspond to the existing guidelines and the manufacturer's operating instructions must be followed.

The headlamp adjuster must be regularly checked by the manufacturer's maintenance service.

The headlamp adjuster is set up according to manufacturer's guidelines and is adjusted to 1,2% inclination for the low beam or 2% inclination for the fog lamp.

According to Guideline 76/756 EEC, the 15° line for low beam on the measurement screen is no longer required. The guideline specifications can however still be set on headlamp adjustment units that have the 15° line on the measurement screen.

The point of intersection of the horizontal line and the inclined line of the light/dark border (point of deflection) must run vertically through the central mark.

To ease determination of the abovementioned point of intersection, one half of the headlamp can be alternatively covered and uncovered a few times.

For headlamps with joint adjustment for low beam and high beam, the centre of light beam at high beam must lie within the corner limits around the central marking (see Fig. 19)

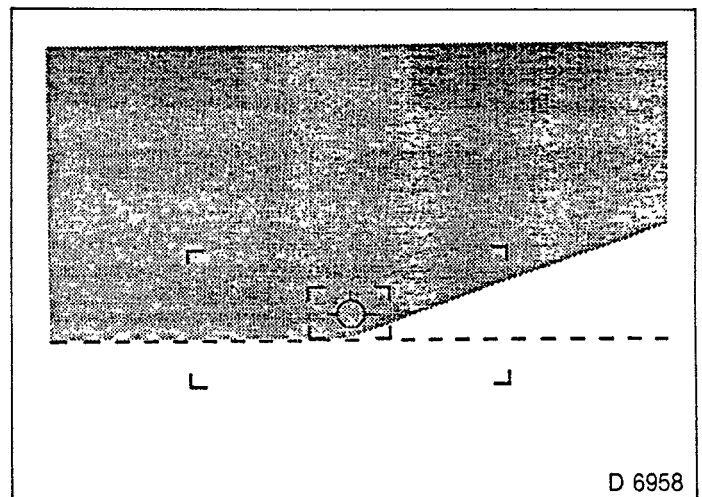


Fig 18

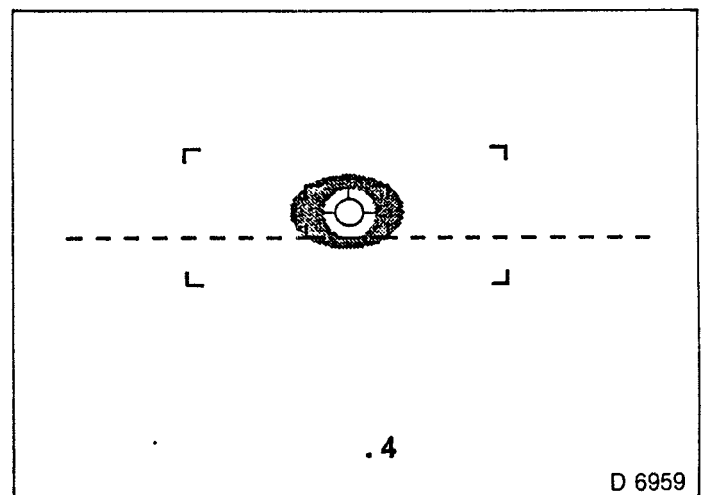


Fig 19

**ADJUST****HEADLAMP****A — Height adjustment****B — Lateral adjustment**

The headlamps must be adjusted according to regulations with an adjusting wall or with an optical headlamp adjustment unit.

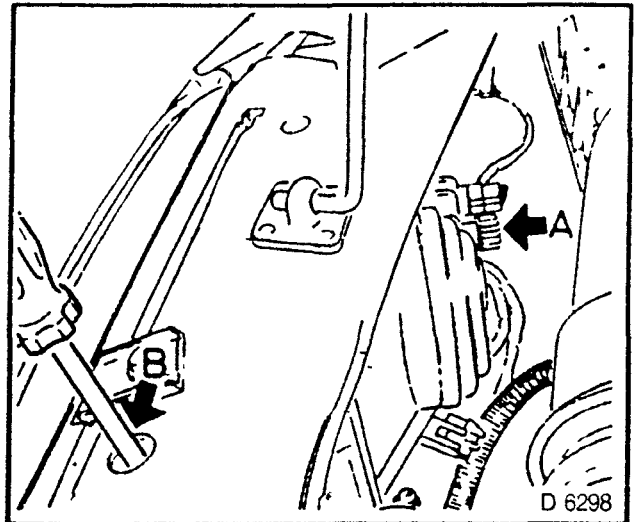


Fig. 20

**Height adjustment**

The left light — dark border of the adjusting cross must be in a horizontal position on the adjustment line.

**Side adjustment**

The light — dark — border must be horizontal from the left side up to adjustment cross and must run from that point to an angle of approximately 15° towards right upper direction. The inclination of the beam is 1,2% in 10 m.

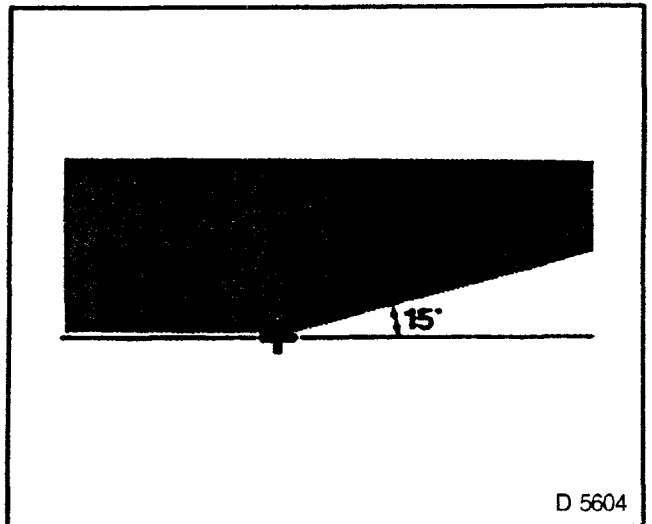


Fig 21

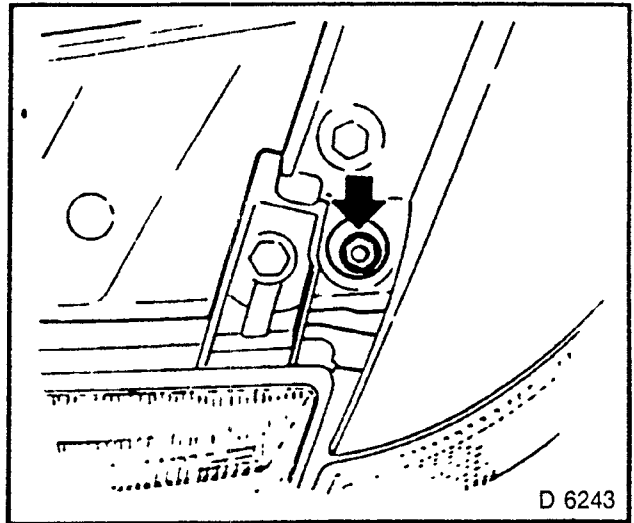
## Turn Signal Lamp, Front — Remove and Install

### REMOVE, DISCONNECT

1. Only loosen bolt, turn signal lamp from bracket.
2. Unlatch wiring harness plug and remove

### INSTALL, CONNECT

1. Wiring harness plug
2. Turn signal lamp.



D 6243

Fig. 22

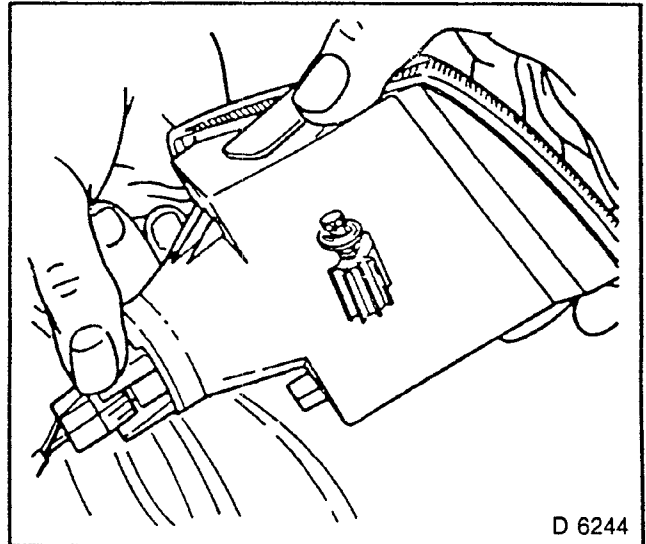
## Bulb — Turn Signal Lamp, Front — Replace

### REMOVE, DISCONNECT

1. Turn signal lamp.
2. Unlatch wiring harness plug and remove.
3. Turn socket out of turn signal lamp
4. Remove bulb.

### INSTALL, CONNECT

1. Bulb.
2. Socket.
3. Wiring harness plug.
4. Turn signal lamp.



D 6244

Fig. 23

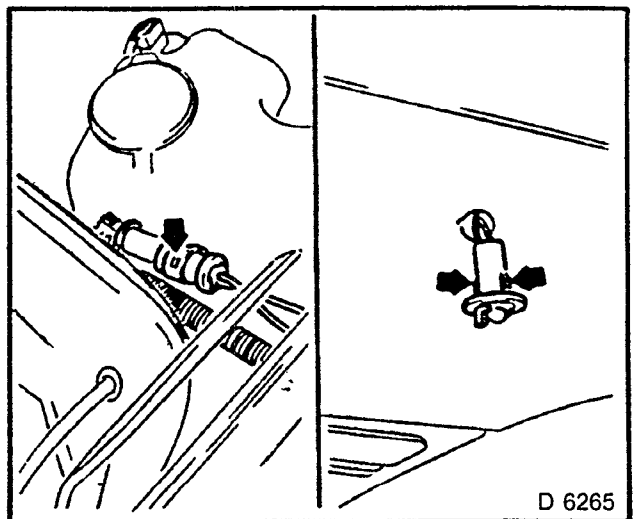
## Side Turn Signal Lamp — Remove and Install

### REMOVE, DISCONNECT

1. Unlatch wiring harness plug and remove.
2. Release turn signal lamp and pull out of wing.

### INSTALL, CONNECT

1. Turn signal lamp.
2. Wiring harness plug.



D 6265

Fig. 24

## Bulb — Side Turn Signal Lamp — Replace

### REMOVE, DISCONNECT

1. Remove turn signal lamp lens.
2. Pull bulb out of turn signal lamp

### INSTALL, CONNECT

1. Bulb
2. Turn signal lamp lens

## Rear Lamp (Astra) — Remove and Install

### REMOVE, DISCONNECT

1. Open cover.
2. Disconnect wiring harness plug and remove.
3. Rear lamp — 4 bolts.

### INSTALL, CONNECT

1. Rear lamp.
2. Wiring harness plug
3. Close cover.

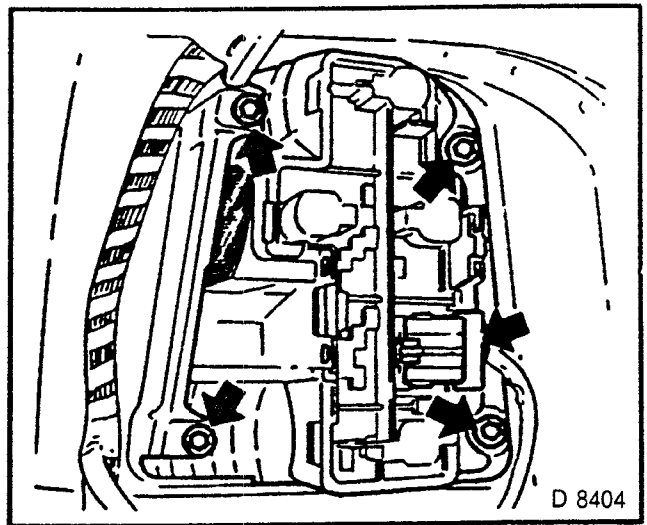


Fig. 25

## Bulb — Rear Lamp (Astra) — Replace

### REMOVE, DISCONNECT

1. Open cover.
2. Disconnect lamp support and remove.
3. Unscrew relevant bulb

### INSTALL, CONNECT

1. Bulb
2. Lamp support.
3. Close cover.

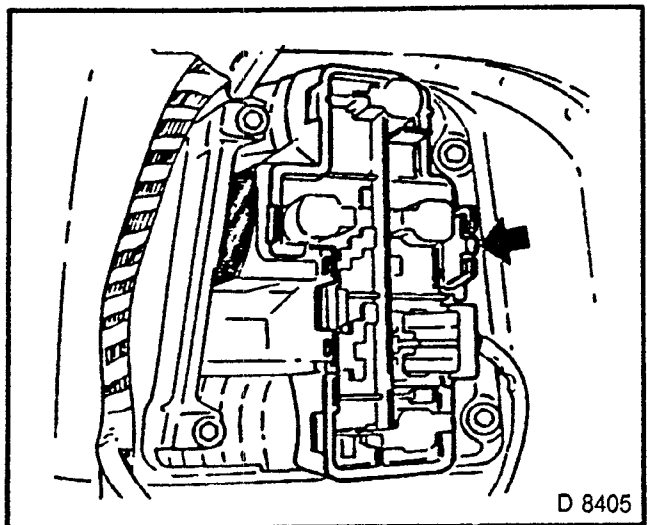


Fig. 26

## Rear Lamp (Kadett) — Remove and Install

### REMOVE, DISCONNECT

1. Remove cover.
2. Disconnect lamp support (1) and remove.
3. Rear lamp — four bolts.

### INSTALL, CONNECT

1. Rear lamp
2. Lamp support.
3. Cover.

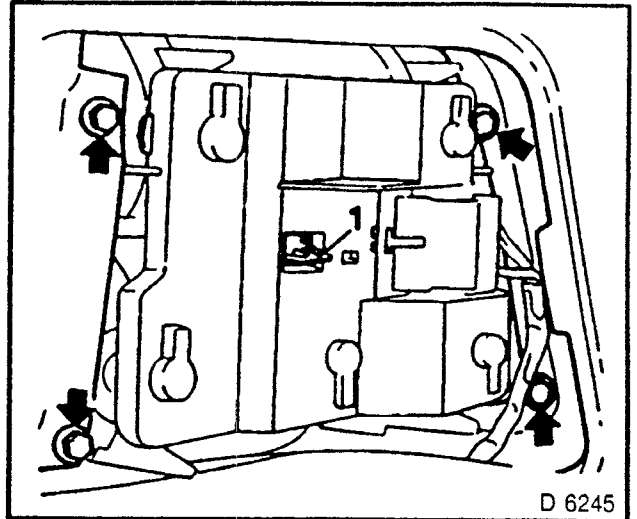


Fig. 27

## Bulb — Rear Lamp (Kadett) — Replace

### REMOVE, DISCONNECT

1. Remove cover.
2. Disconnect lamp support and remove.
3. Unscrew relevant bulb.

### INSTALL, CONNECT

1. Bulb.
2. Lamp support.
3. Cover.

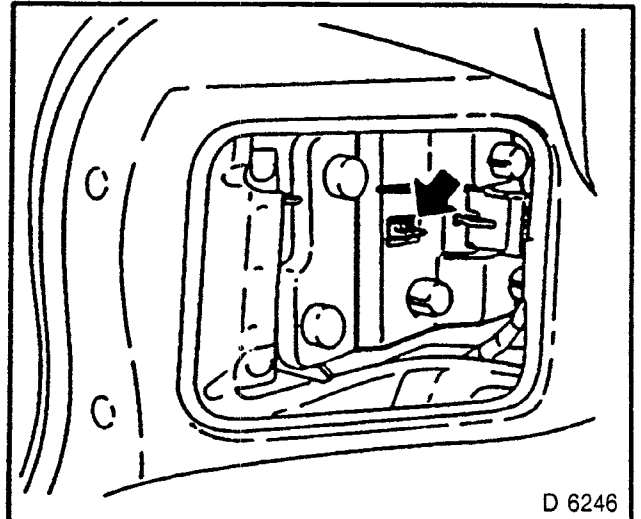


Fig. 28

## License Plate Lamp — Remove and Install

### REMOVE, DISCONNECT

1. Unlatch license plate lamp with a small screwdriver.
2. Remove from rear trim.
3. Remove cable.

### INSTALL, CONNECT

1. Cable.
2. License plate lamp.

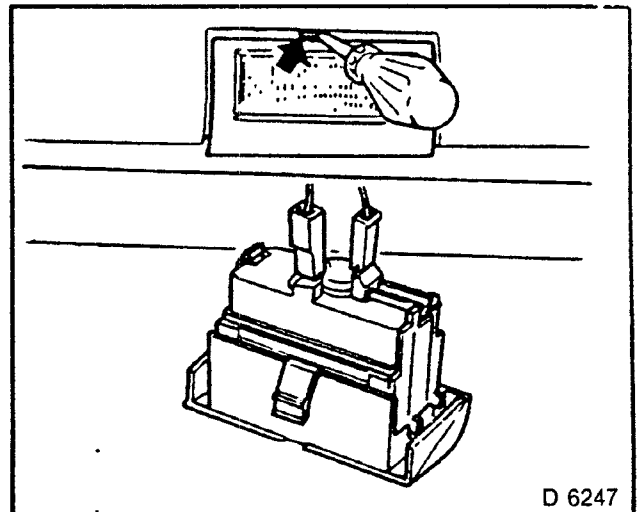


Fig. 29

## Bulb — License Plate Lamp — Replace

### REMOVE, DISCONNECT

1. Release license plate lamp
2. Remove from rear panelling.
3. Lamp support.
4. Bulb

### INSTALL, CONNECT

1. Bulb
2. Lamp support.
3. License plate lamp.

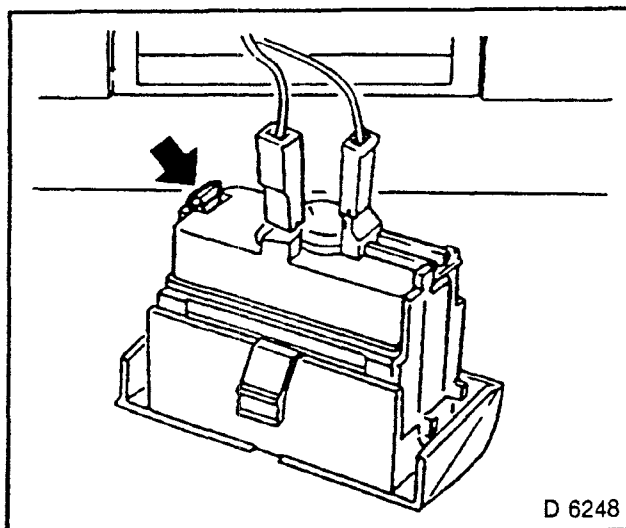


Fig. 30

## Interior Lamp — Remove and Install

### REMOVE, DISCONNECT

1. Unclip interior lamp from panel.
2. Wiring harness plug from interior lamp.

### INSTALL, CONNECT

1. Wiring harness plug.
2. Interior lamp

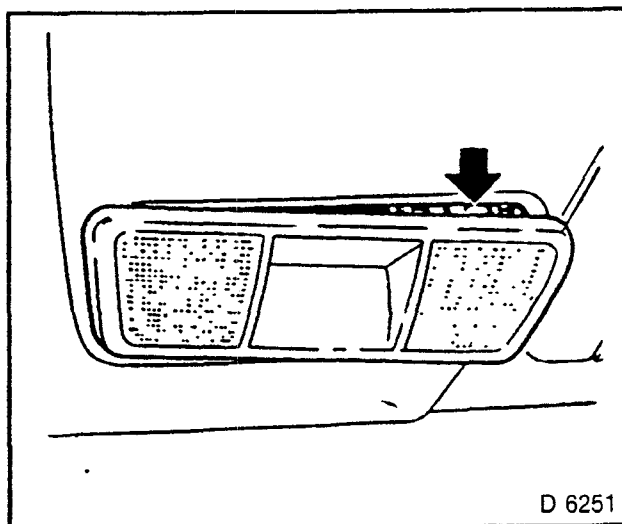


Fig. 31

## Bulb — Interior Lamp — Replace

### REMOVE, DISCONNECT

1. Unclip interior lamp from cover.
2. Remove glass from interior lamp
3. Remove bulb.
4. Bulb.

### INSTALL, CONNECT

1. Bulb
2. Glass.
3. Interior lamp.

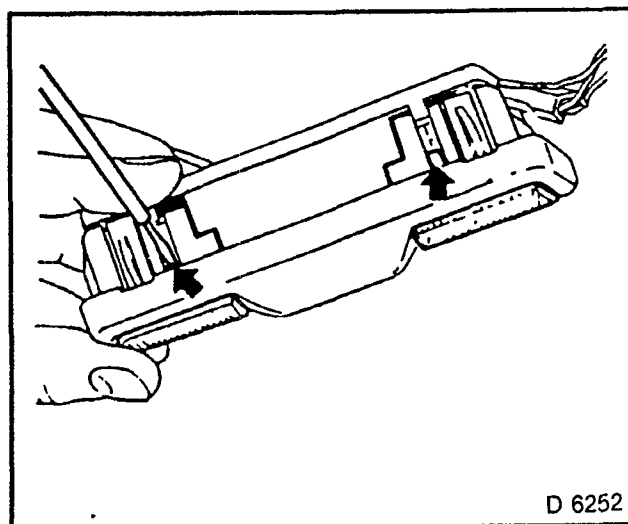


Fig. 32



## Rear Reading Lamp — Remove and Install

### REMOVE, DISCONNECT

1. Carefully lever out reading lamp from assist handle with small screwdriver.
2. Remove wiring harness plug.

### INSTALL, CONNECT

1. Wiring harness plug.
2. Reading lamp in assist handle.

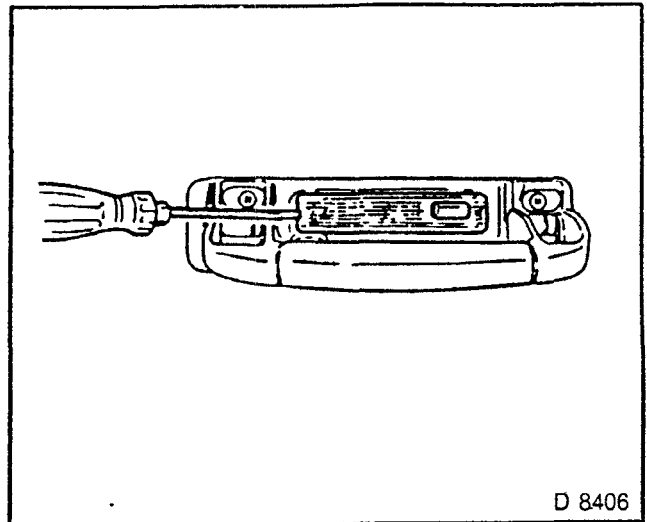


Fig 33

## Bulb — Rear Reading Lamp — Replace

### REMOVE, DISCONNECT

1. Carefully lever out reading lamp from assist handle with small screwdriver.
2. Remove wiring harness plug.
3. Carefully disconnect heat shield
4. Remove bulb.

### INSTALL, CONNECT

1. Bulb
2. Heat shield
3. Wiring harness plug.
4. Reading lamp in assist handle

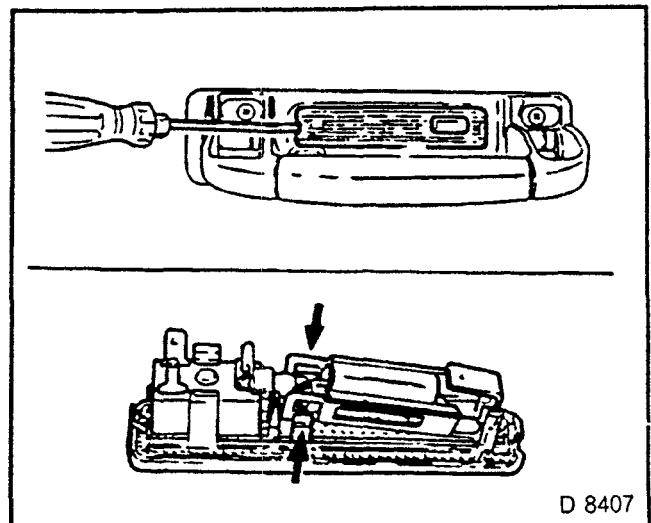


Fig 34

## Headlamp — Remove and Install

### REMOVE, DISCONNECT

- 1 Radiator grille.
- 2 Turn signal lamp.
- 3 Headlamp.
- 4 Multiplug from bulb.
- 5 Headlamp range control motor.

### INSTALL, CONNECT

1. Both multiplugs.
2. Headlamp.
3. Turn signal lamps.
4. Radiator grille.

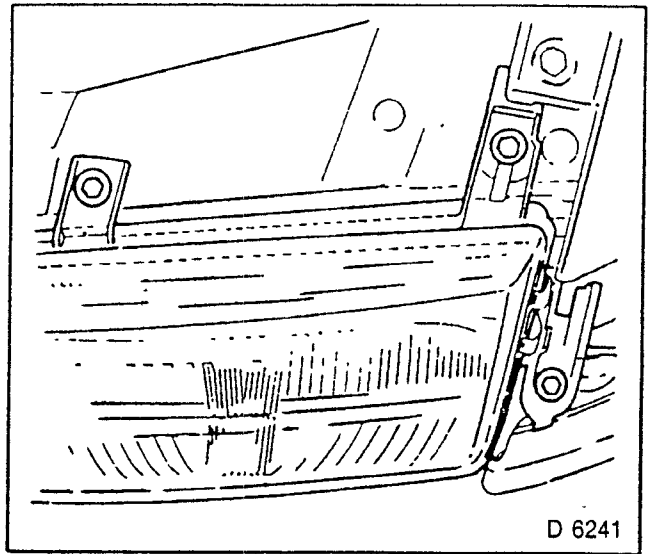


Fig 35

## Headlamps with Headlamp Range Control — Replace

### REMOVE, DISCONNECT

1. Pull radiator grille forwards (1).
2. Pull lower bracket upwards out of front panelling (2).
3. Headlamp washer system hose (if present).

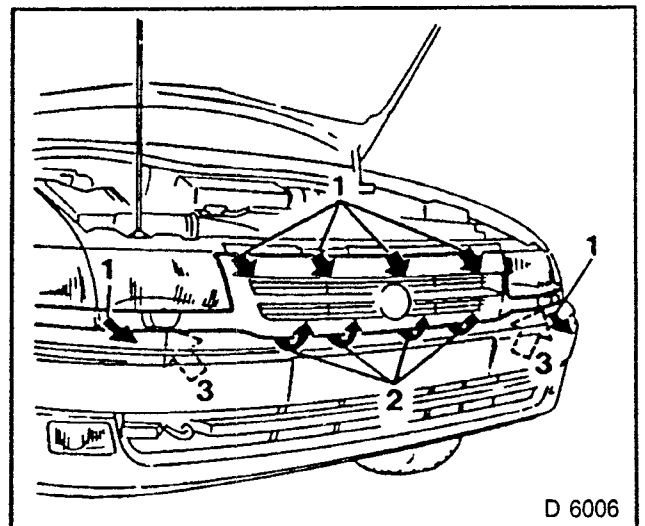


Fig 36

4. Loosen turn signal unit bolt (1) and remove forward from bracket.
5. Unbolt headlamp (2).
6. Wiring harness plug from bulb
7. Headlamp range control motor.

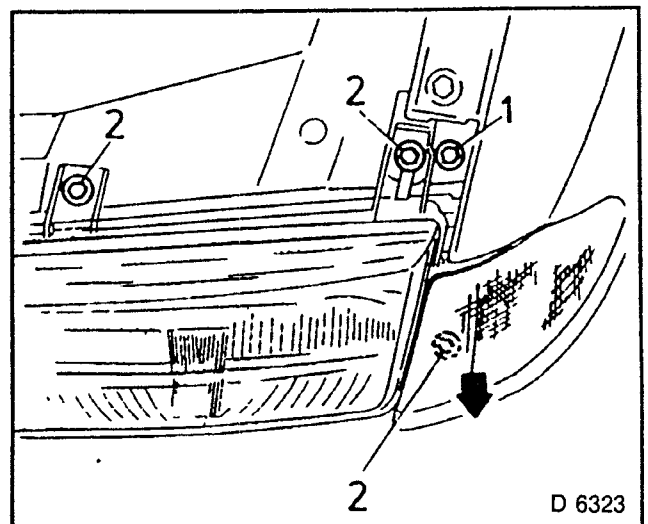


Fig 37

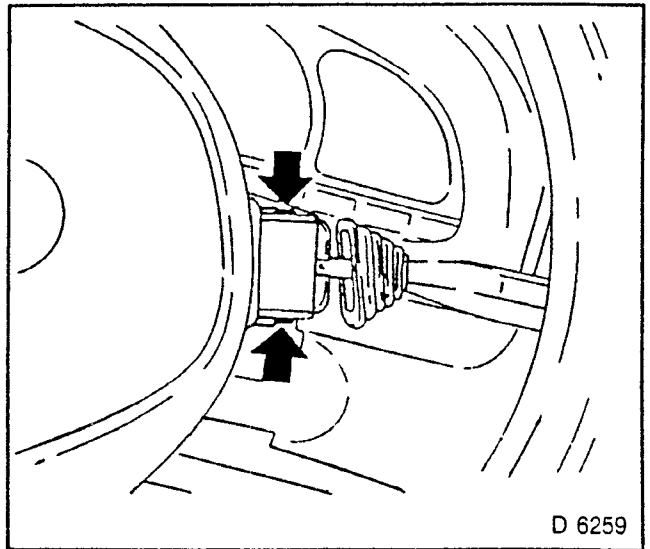
## Turn Signal/Wiper Switch — Remove and Install

### REMOVE, DISCONNECT

- 1 Signal switch panelling
2. Unlatch signal/wiper switch and remove
3. Unlatch wiring harness plug and remove

### INSTALL, CONNECT

- 1 Wiring harness plug.
2. Signal/wiper switch.
3. Signal switch cover.



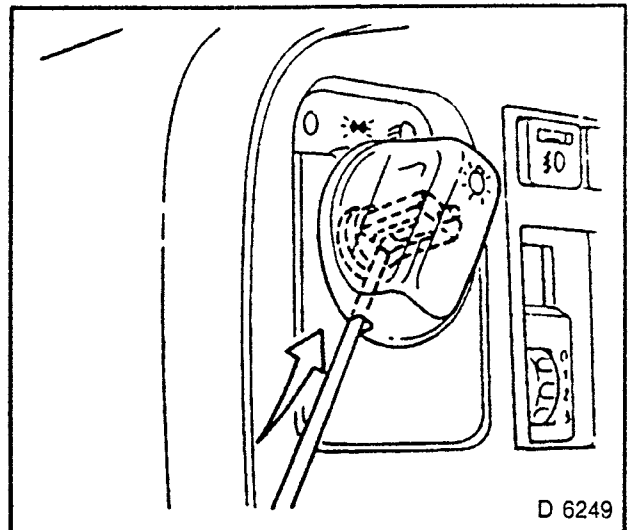
D 6259

Fig. 38

## Light and Interior Lamp Switch — Remove and Install

### REMOVE, DISCONNECT

1. Turn rotary knob to low beam "ON" position and remove.
2. Unlatch rotary knob with small screwdriver or electrode wire.



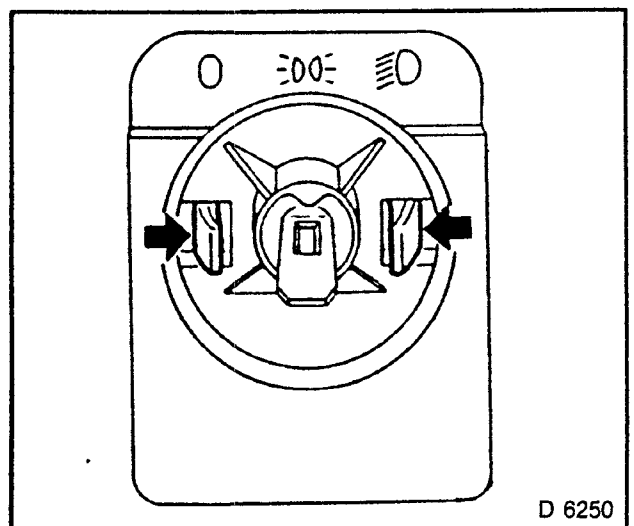
D 6249

Fig. 39

- 3 Press together catch.
4. Remove light and interior lamp switch from wiring harness plug.

### INSTALL, CONNECT

1. Light and interior lamp switch.
2. Rotary knob.



D 6250

Fig. 40

## Hazard Warning Lamp Switch — Remove and Install

**WARNING:**  
ONLY REMOVE HAZARD WARNING LAMP SWITCH WHEN IN "ON" POSITION.

### REMOVE, DISCONNECT

- 1 Hazard warning lamp switch in "ON" position, carefully lever out key.
2. Unlock hazard warning lamp switch and pull off from base.

### INSTALL, CONNECT

1. Hazard warning lamp switch.
2. Cover.

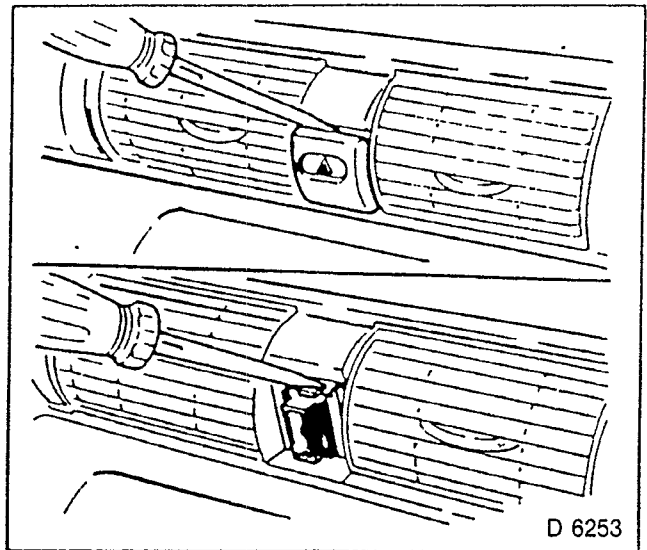


Fig 41

## Signal Switch — Remove and Install

### REMOVE, DISCONNECT

1. Pull signal switch from steering wheel.
2. Remove cable.

### INSTALL, CONNECT

1. Cable.
- 2 Signal switch.

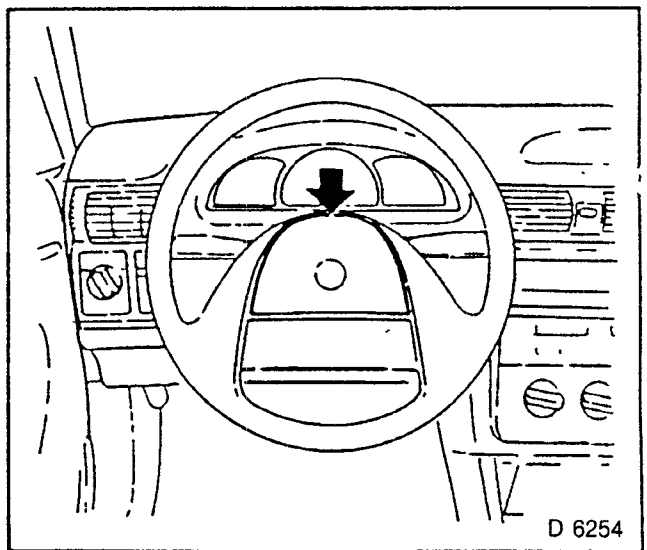


Fig. 42

## Brake Lamp Switch — Remove and Install

### REMOVE, DISCONNECT

1. Footwell panelling on driver's side.
2. Disconnect multiplug and remove
3. Turn brake lamp switch to left.

### INSTALL, CONNECT

1. Brake lamp switch.
2. Multiplug
3. Footwell panelling.

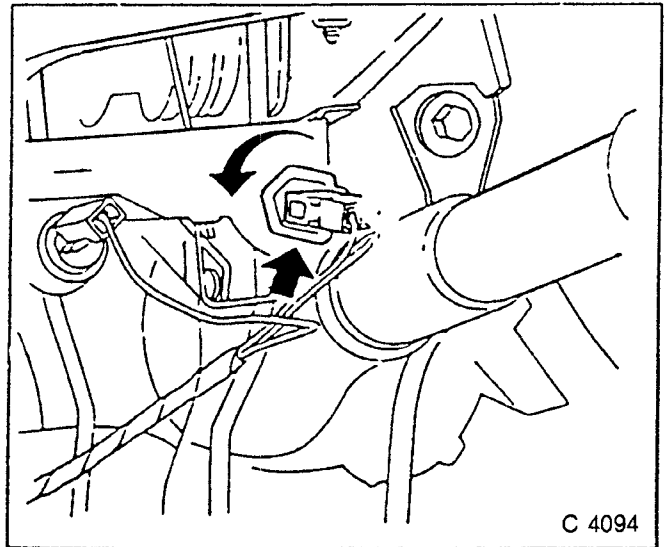


Fig. 43

## Parking Brake Telltale Switch — Remove and Install

### REMOVE, DISCONNECT

1. Left seat (Front Seat, Remove and Install Section C).
2. Centre console (Centre Console, Remove and Install Section C).
3. Release parking brake lever (Parking Brake Lever, Remove and Install Section H)
4. Switch from parking brake lever.
5. Flat socket from switch.

### INSTALL, CONNECT

1. Wiring plug.
2. Switch.
3. Parking brake lever
4. Centre console.
5. Seat

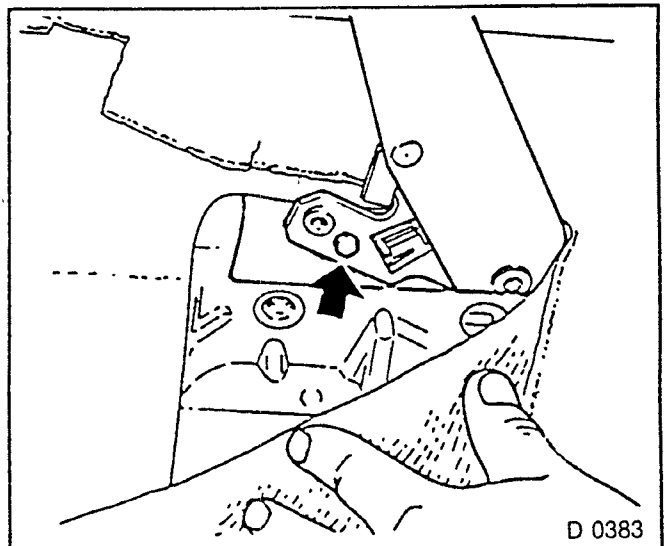


Fig. 44

## Horn — Remove and Install

### REMOVE, DISCONNECT

- 1 Radiator grille (Section A).
2. Cable from horn
3. Horn from air deflector panel.

### INSTALL, CONNECT

- 1 Horn.
2. Cable
- 3 Radiator grille.

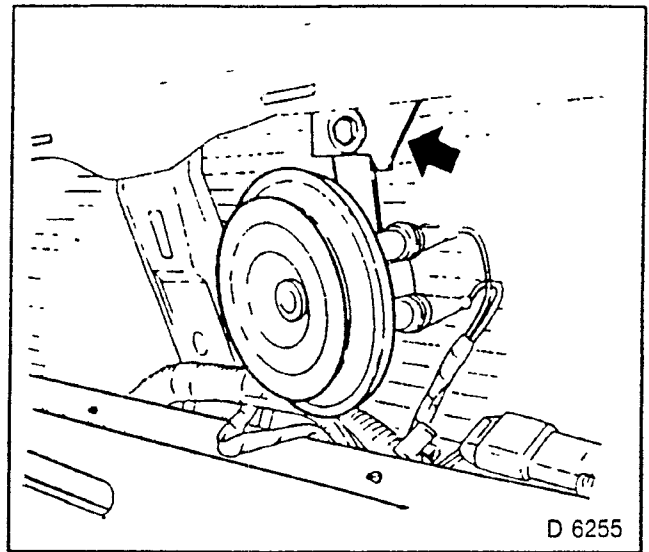


Fig. 45

## Signal Switch Cover — Remove and Install

### REMOVE, DISCONNECT

1. Signal switch cover — five bolts
2. Steering wheel removed for better viewing.

### INSTALL, CONNECT

- 1 Signal switch cover

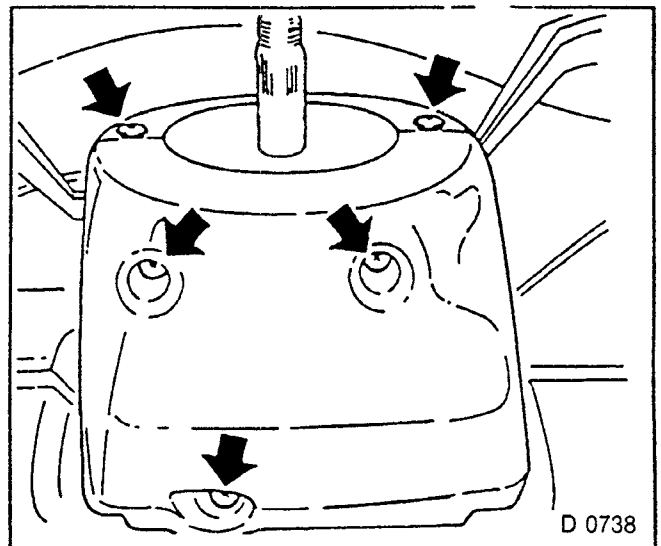


Fig. 46

## Fog Lamp Switch — Remove and Install

Prepare tool (see Fig. 47)

### REMOVE, DISCONNECT

1. Pull lamp switch from base.

### INSTALL, CONNECT

1. Insert fog lamp switch in base.

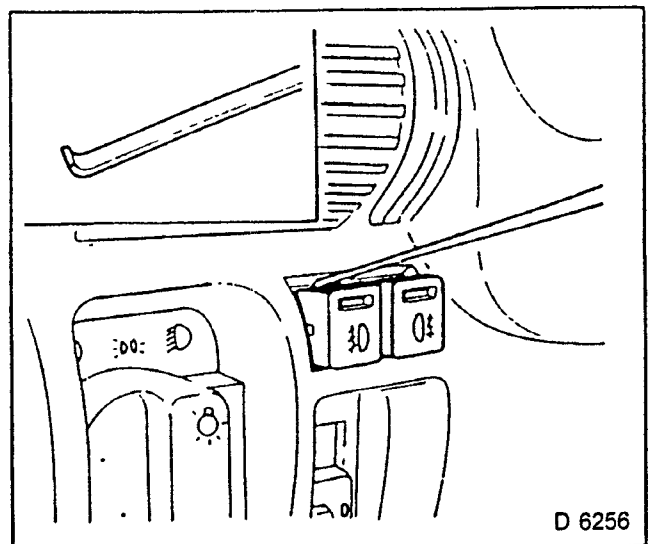


Fig. 47

## STEERING AND IGNITION LOCK

### Contact Piece for Steering and Ignition Lock — Replace

#### REMOVE, DISCONNECT

- 1 Signal switch panelling — five bolts.
- 2 Remove cover from below steering wheel (clipped).
- 3 Unscrew two headless screws opposite one another.
- 4 Remove contact piece from steering and ignition lock.
- 5 Release wiring harness plug and remove.

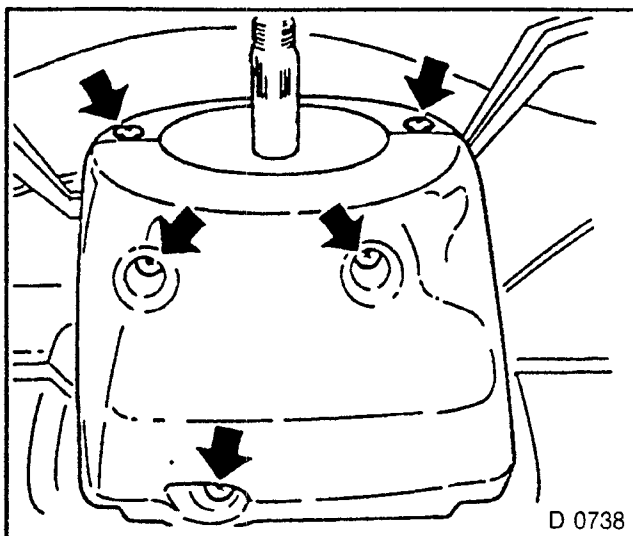


Fig. 48

**NOTE:**  
CHECK POSITION OF SWITCH PIECE  
IN CONTACT PIECE, CORRECT IF  
NECESSARY.

#### INSTALL, CONNECT

1. Wiring harness plug.
2. Contact piece.
3. Signal switch panelling.

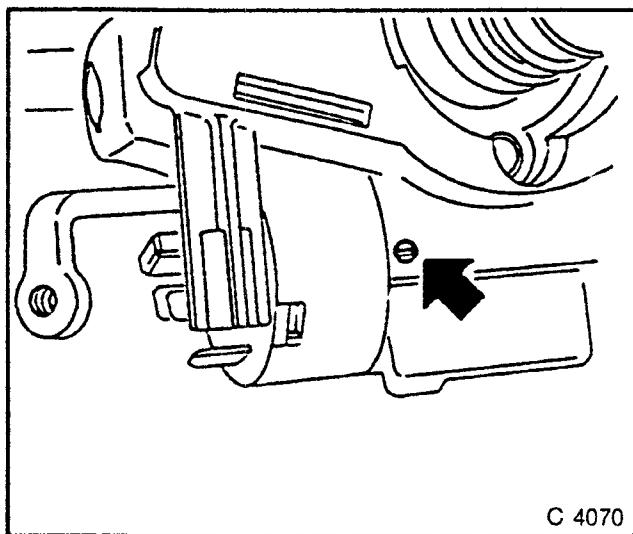


Fig. 49

## Lock Cylinder for Steering and Ignition Lock — Replace

- 1 Signal switch panelling — five bolts.
- 2 Turn ignition lock to position "II".

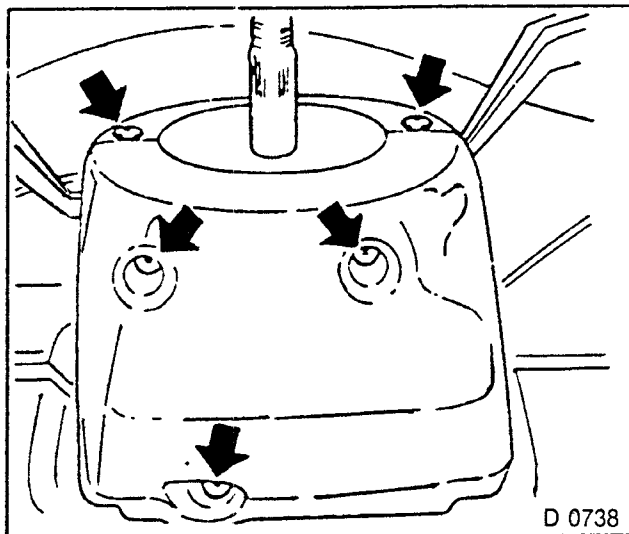


Fig. 50

- 3 Press down detent springs and at same time,
4. Pull lock cylinder out of steering lock.

**CAUTION:**  
**UNDER NO CIRCUMSTANCES REMOVE CONTACT PIECE, TO PREVENT DAMAGE TO STEERING AND IGNITION LOCK.**

### INSTALL, CONNECT

1. Push lock cylinder into steering lock until detent springs engage.
2. Signal switch panelling

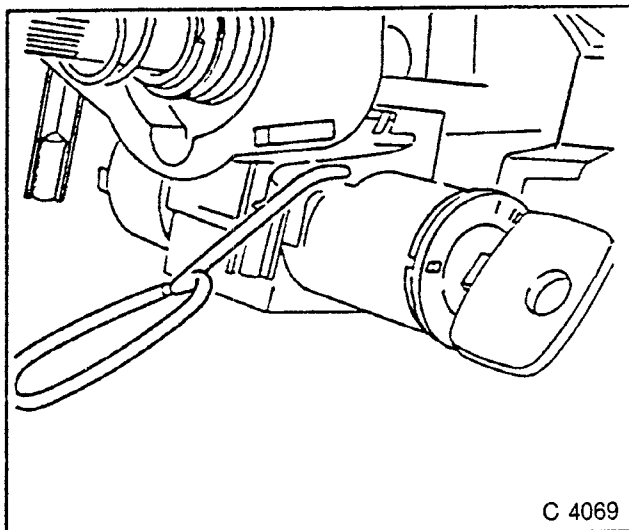


Fig 51



## INSTRUMENTS

### Instrument Housing Cover — Remove and Install

#### REMOVE, DISCONNECT

1. Signal switch cover — five bolts.
2. Steering wheel removed for better viewing

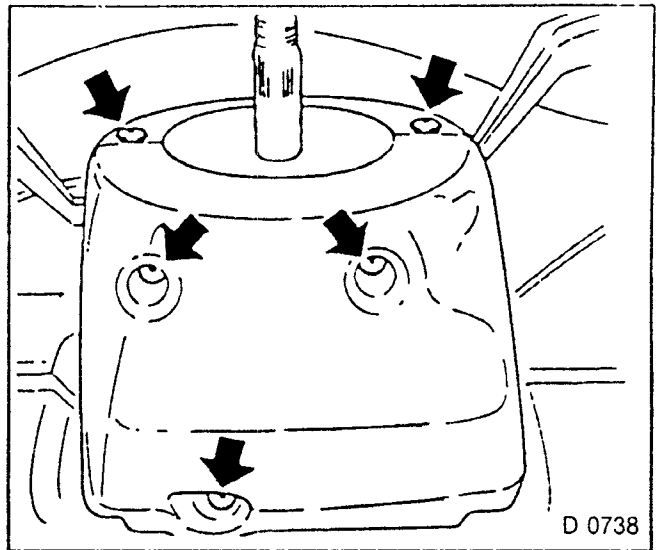


Fig 52

3. Instrument housing cover — four bolts.

#### INSTALL, CONNECT

1. Instrument housing cover
2. Signal switch cover.

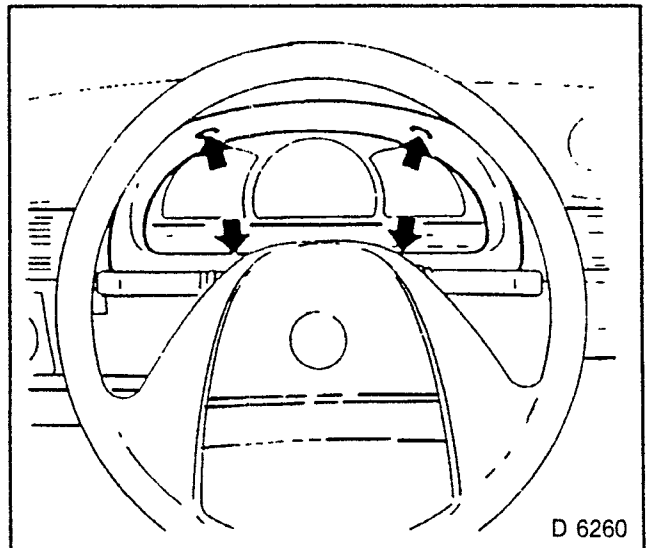


Fig 53

### Instrument Assembly — Remove and Install

#### REMOVE, DISCONNECT

1. Disconnect battery.
2. Unbolt speedometer cable from transmission.
3. Signal switch cover Page 29.
4. Instrument housing cover.
5. Loosen instrument assembly.

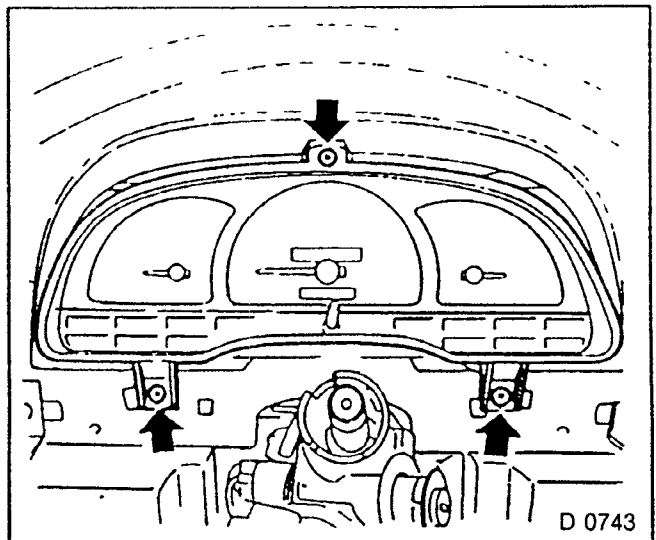


Fig. 54

6. Instrument assembly from instrument panel
7. Press down retaining spring from speedometer cable and remove.
8. Unlatch both multiplugs and remove.

### INSTALL, CONNECT

1. Multiplug
2. Speedometer cable.
3. Instrument assembly
4. Instrument housing cover
5. Signal switch cover.
6. Speedometer cable to transmission
7. Connect battery.

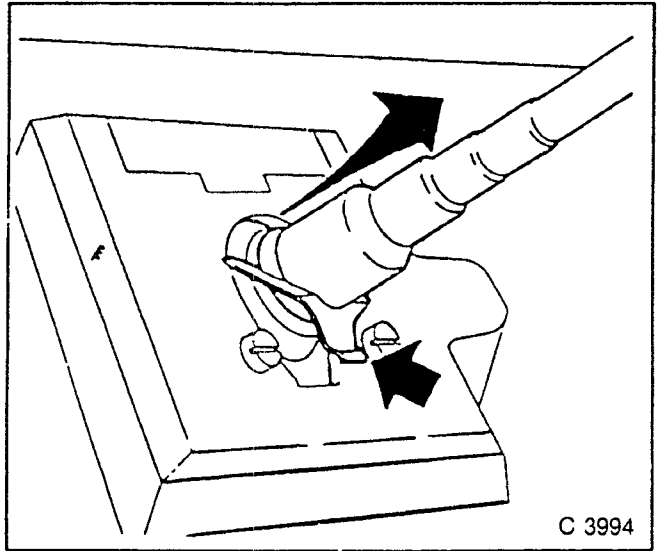


Fig 55

## Temperature Gauge, Fuel Gauge — Remove and Install

### REMOVE, DISCONNECT

#### INSTRUMENT ASSEMBLY — (See page 32)

1. Pull off pin for trip odometer.
2. Raise clip and remove instrument glass.

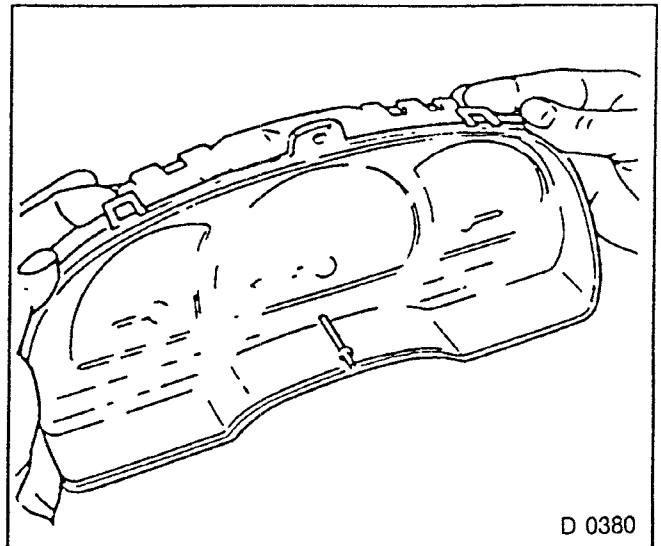


Fig. 56

3. Unbolt two bolts (1).
4. Remove instrument from instrument housing.

### INSTALL, CONNECT

1. Instrument.
2. Instrument glass.
3. Pin for trip odometer.
4. Instrument assembly

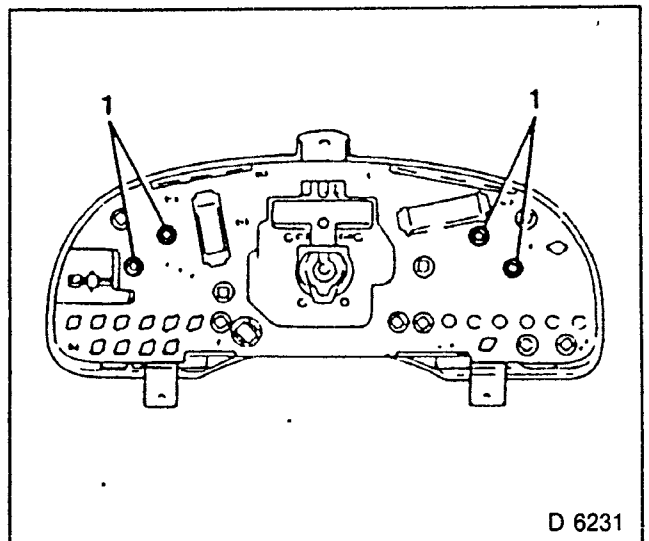


Fig 57

## Speedometer — Remove and Install

### REMOVE, DISCONNECT

Instrument assembly (see page 32).

1. Remove pin for trip odometer.
2. Raise tab.
3. Remove instrument housing cover.
4. Remove clamp (2) from odometer frequency sensor
5. Remove (1 bolt)
6. Carefully loosen printed circuit board (1).
7. Speedometer — four bolts (3)

### INSTALL, CONNECT

1. Speedometer.
2. Odometer frequency sensor
3. Clamp.
4. Instrument housing cover
5. Pin for trip odometer.
6. Instrument assembly.

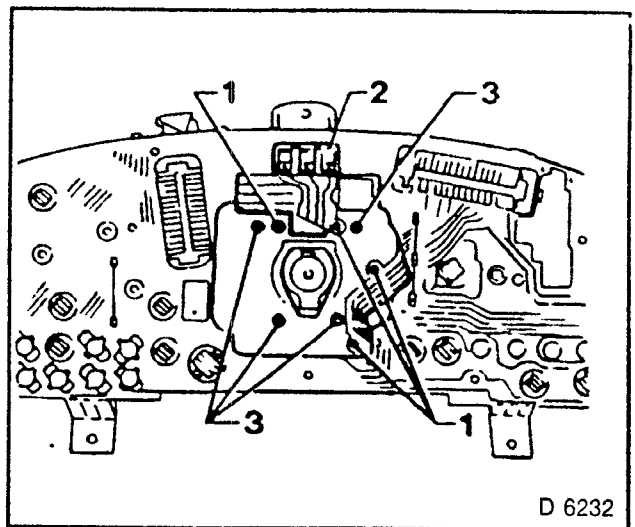


Fig. 58

## Voltage Stabilizer — Remove and Install

### REMOVE, DISCONNECT

Instrument assembly (See page 32).

1. Unbolt voltage stabilizer from instrument housing.
2. Remove from plug contacts.

### INSTALL, CONNECT

1. Voltage stabilizer.
2. Instrument assembly.

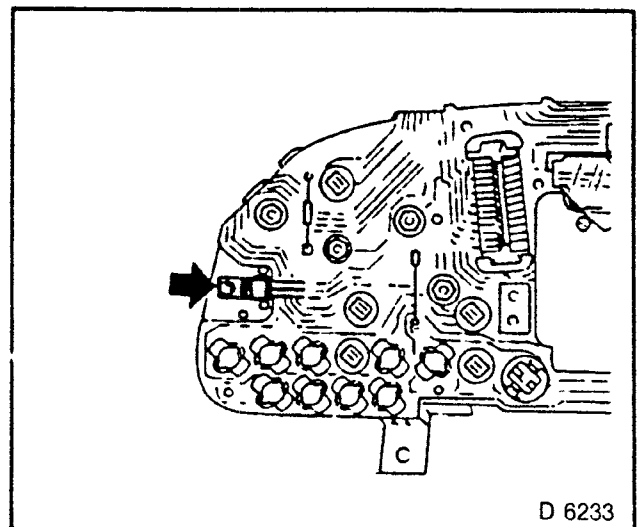


Fig. 59

## Printed Circuit Board — Remove and Install

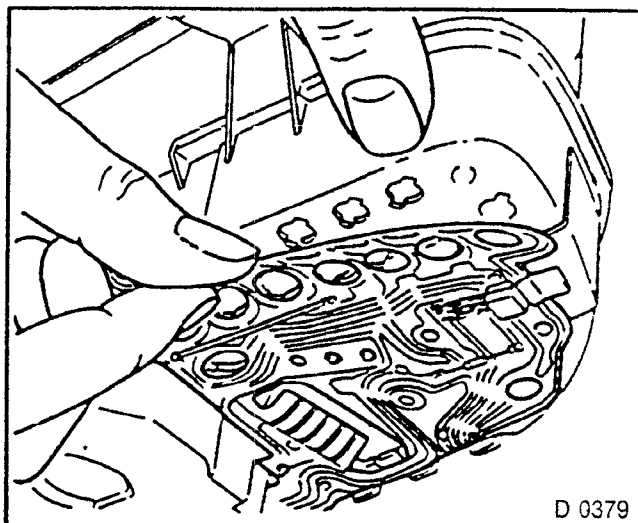
### REMOVE, DISCONNECT

Instrument assembly (see page 32).

1. All instruments.
2. Instruments telltales.
3. Voltage stabilizer.
4. Printed circuit board from instrument housing.

### INSTALL, CONNECT

1. Printed circuit board.
2. Voltage stabilizer.
3. Instruments
4. Instrument/telltales.
5. Instrument assembly.



D 0379

Fig 60

## Instrument/Telltales — Replace

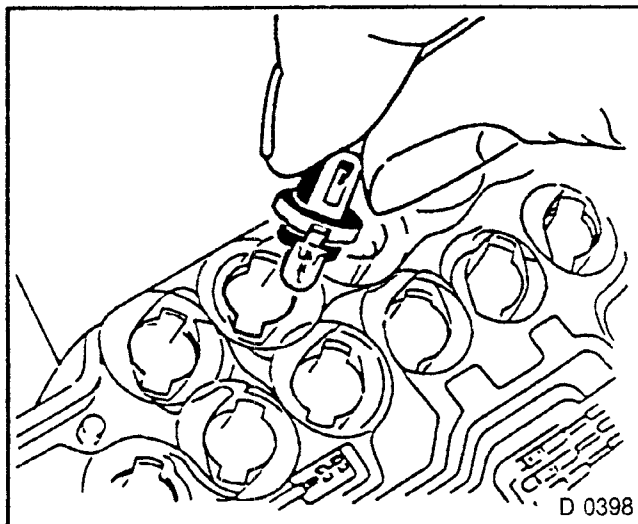
### REMOVE, DISCONNECT

Instrument assembly (See page 32).

1. Turn instrument/telltales to left.

### INSTALL, CONNECT

1. Instrument/telltales.
2. Instrument assembly.



D 0398

Fig. 61

## Tachometer — Remove and Install

### REMOVE, DISCONNECT

Instrument assembly (see page 32).

1. Remove pin for trip odometer.
2. Raise tabs and remove.
3. Instrument housing cover.
4. Unscrew speedometer.
5. Loosen printed circuit board partially (arrow)
6. Remove plug contact.

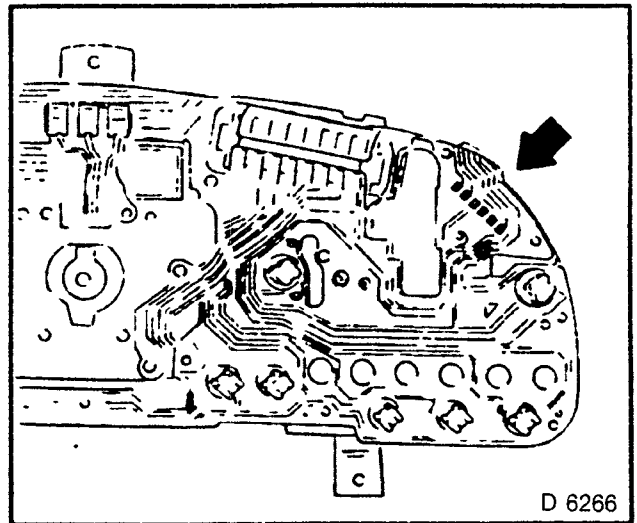


Fig. 62

7. Unbolt tachometer from instrument housing.

### INSTALL, CONNECT

1. Tachometer.
2. Plug contact.
3. Fasten printed circuit board.
4. Speedometer
5. Instrument housing cover
6. Pin for trip odometer
7. Instrument assembly.

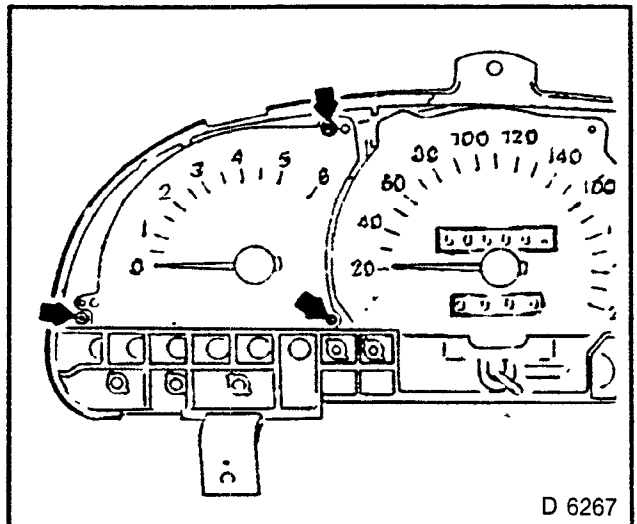


Fig. 63

## CENTRAL DOOR LOCKING

### Servo Motor — Driver's Door, Adjust REMOVE, DISCONNECT

1. Disconnect battery
2. Door inner panelling (see Section C)
3. Door lock/servo motor assembly (see Section C)

### ADJUST

1. Press slider (1) of servo motor into closed position and hold in place.
2. Loosen bolt (2) of servo motor.
3. Position lock lever so that it rests on rubber buffer by moving servo motor.
4. Tighten bolt.

### INSTALL, CONNECT

1. Door lock/servo motor assembly.
2. Connect battery
3. Check function.
4. Install door inner panelling.
5. If necessary, program electronic components.

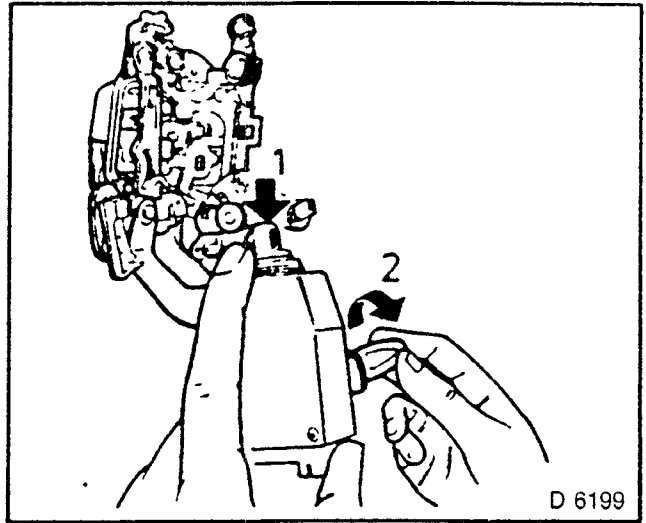


Fig 64

D 6199

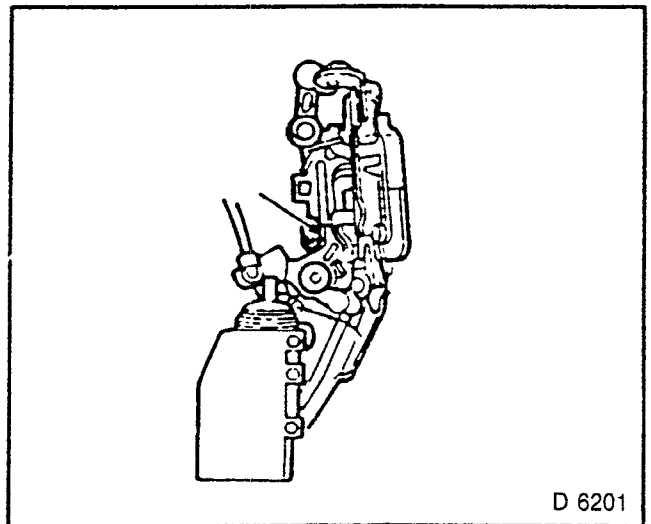


Fig. 65

D 6201

## Servo Motor — Passenger Door, Adjust

### REMOVE, DISCONNECT

- 1 Disconnect battery, door inner panelling (see Section C)
2. Door lock/servo motor assembly (see Section C)

### ADJUST

1. Press slider (1) of servo motor into closed position and hold in place.
2. Loosen bolt (2) of servo motor

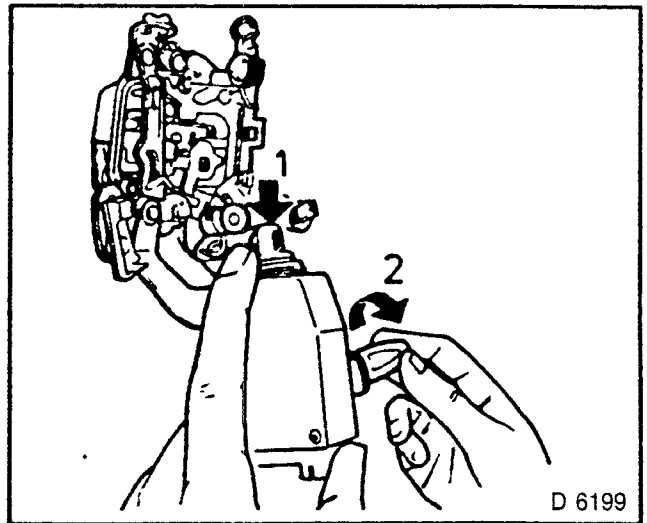


Fig. 66

3. Position lock lever to a distance of 2 mm by moving servo motor.
- 4 Tighten bolt.

### INSTALL, CONNECT

1. Door lock/servo motor assembly.
2. Connect battery.
3. Check function.
4. Install door inner panelling.
5. If necessary, program electronic components (e.g. board computer, electric window winders).

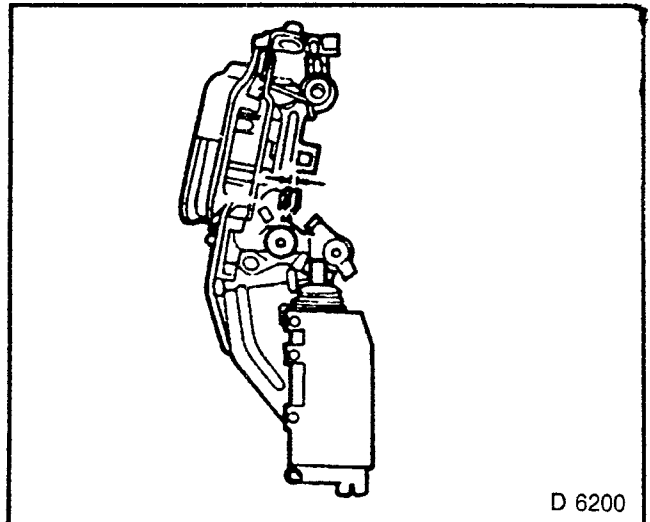


Fig 67

## Servo Motor — Rear Doors Adjust

### REMOVE, DISCONNECT

1. Disconnect battery.
2. Door inner panelling (see Section C)
3. Door lock/servo motor assembly (see Section C)

### ADJUST

1. Press slider (1) of servo motor into closed position and hold in place.
2. Loosen bolt (2) of servo motor.

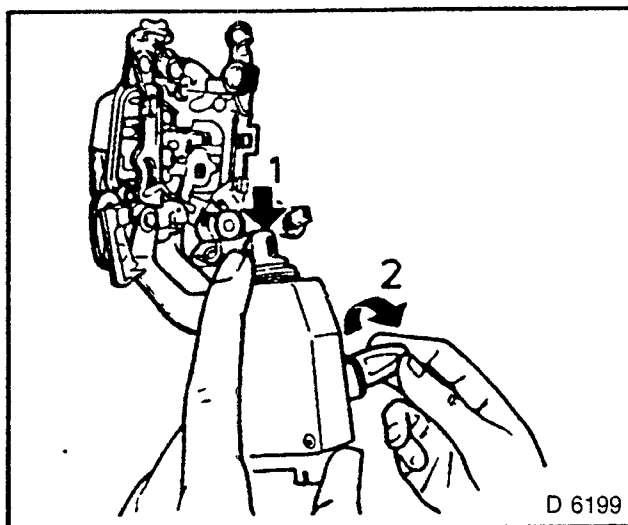


Fig. 68

3. Position lock lever to a distance of 2 mm by moving servo motor.
4. Tighten bolt.

### INSTALL, CONNECT

1. Door lock/servo motor assembly.
2. Connect battery.
3. Check function.
4. Install door inner panelling.
5. If necessary, program electronic components (e.g. board computer, electric window winders).

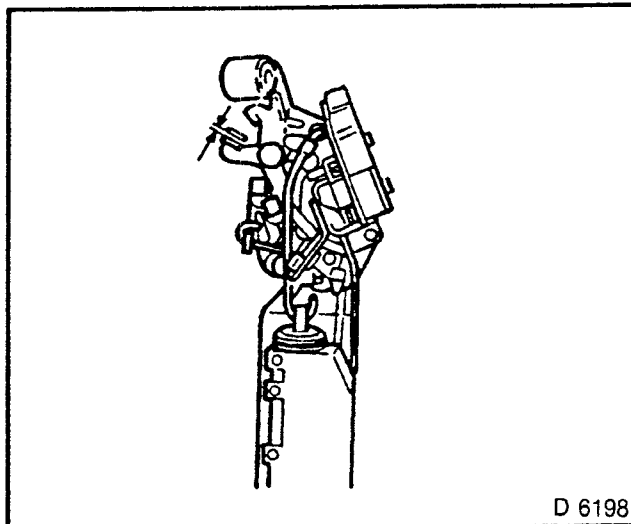


Fig. 69

## Control Unit — Remove and Install

### REMOVE, DISCONNECT

1. Right sill panelling (See Section C).
2. Control unit.
3. Wiring harness plug from control unit.

### INSTALL, CONNECT

1. Control unit.
2. Wiring harness plug.
3. Right sill panelling.

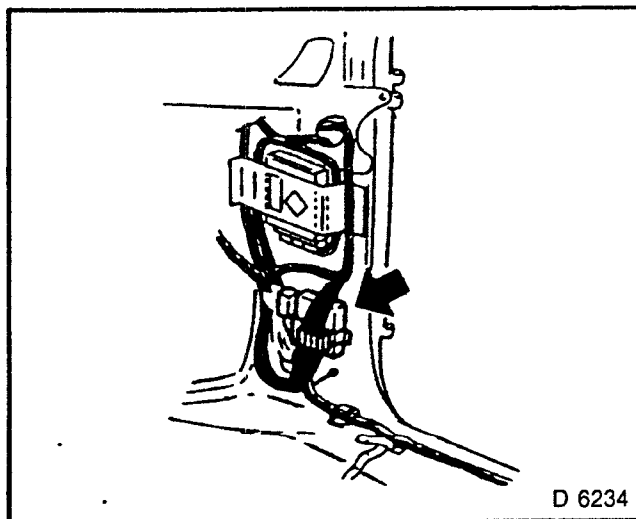


Fig. 70



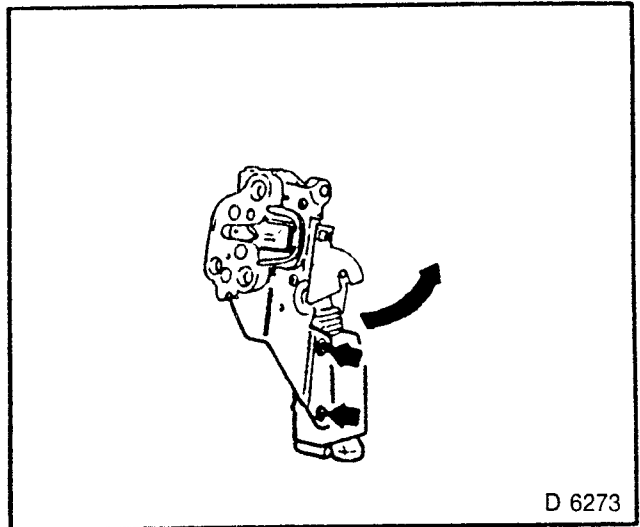
## Servo Motor (Front Door) — Remove and Install

### REMOVE, DISCONNECT

1. Inner door trim panel (See Section C).
2. Door lock (See Section C).
3. Servo motor from lock.

### INSTALL, CONNECT

1. Servo motor.
2. Door lock
3. Inner door trim panel.



D 6273

Fig 71

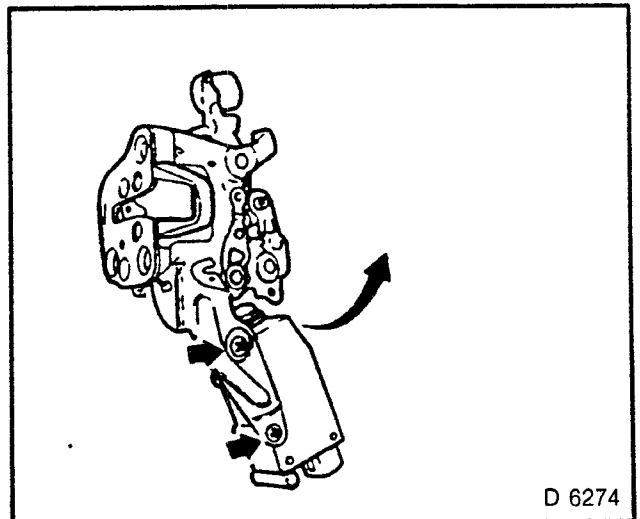
## Servo Motor (Rear Door) — Remove and Install

### REMOVE, DISCONNECT

1. Inner door trim panel (See Section C).
2. Door lock (See Section C).
3. Servo motor from door lock.

### INSTALL, CONNECT

1. Servo motor.
2. Door lock
3. Inner door trim.



D 6274

Fig 72

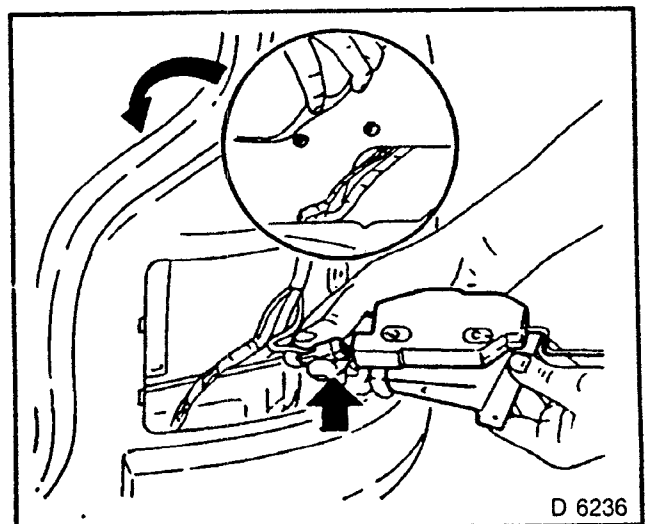
## Servo Motor (Fuel Filler Flap) — (Kadett) — Remove and Install

### REMOVE DISCONNECT

1. Luggage compartment side panelling, right rear lamp (see Section C).
2. Servo motor from rear quarter panel.
3. Disconnect wiring harness plug and remove.

### INSTALL, CONNECT

1. Wiring harness plug.
2. Servo motor.
3. Rear lamp.
4. Luggage compartment side panelling.



D 6236

Fig. 73

## Servo Motor (Fuel Filler Flap) (Astra) — Remove and Install

### REMOVE, DISCONNECT

1. Rear quarter rear right panelling (See Section C)
2. Servo motor from rear quarter panel.
3. Disconnect wiring harness plug and remove.

### INSTALL, CONNECT

1. Wiring harness plug.
2. Servo motor.
3. Rear quarter panelling.

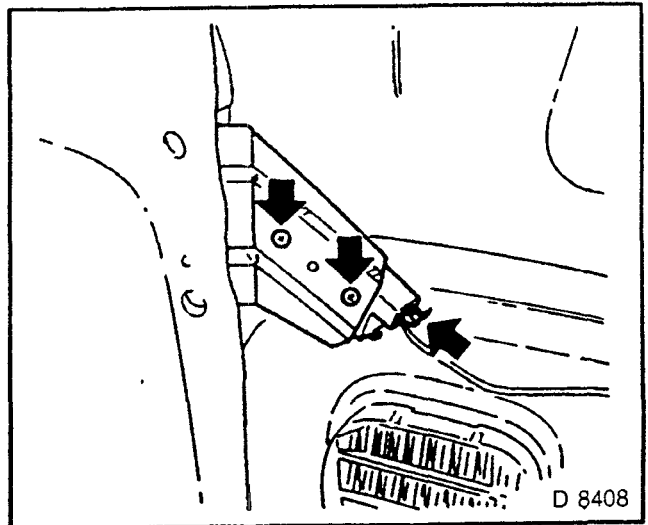


Fig. 74

## Servo Motor (Luggage Compartment Lid) (Astra) — Remove and Install

### REMOVE, DISCONNECT

1. Unscrew cover.
2. Disconnect wiring harness plug and remove.
3. Servo motor from luggage compartment lid.

### INSTALL, CONNECT

1. Servo motor.
2. Wiring harness plug.
3. Cover.

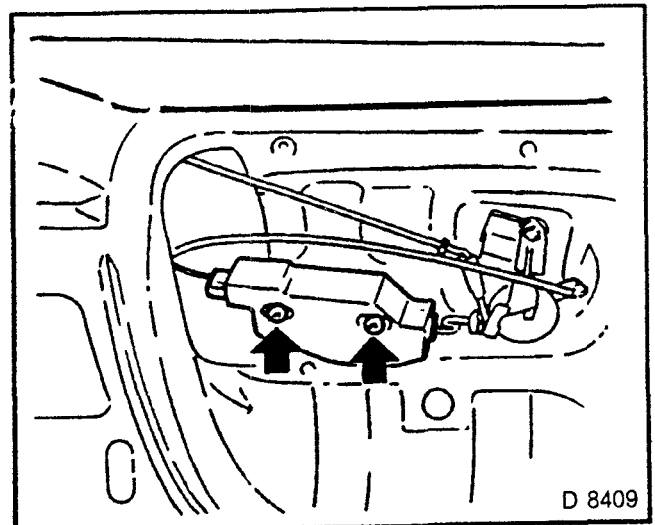


Fig. 75

## Servo Motor (Tailgate) (Kadett) — Remove and Install

### REMOVE, DISCONNECT

1. Tailgate panelling — (see Section C).
2. Servo motor from tailgate.
3. Disconnect wiring harness plug and remove.

### INSTALL, CONNECT

1. Wiring harness plug.
2. Servo motor.
3. Tailgate panelling.

## Switch (Driver's Door) — Remove and Install

### REMOVE, DISCONNECT

Inner door trim (See Section C)

1. Clamp.
2. Switch with electronic connections.
3. Separate plug connections at wiring harness door.

### INSTALL, CONNECT

1. Switch.
2. Plug connection.
3. Inner door trim.

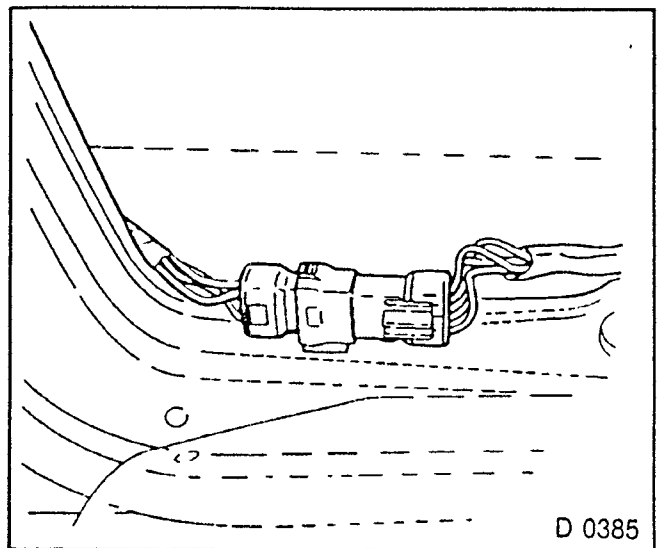


Fig. 76

## DISPLAY SYSTEMS

### Function Display — Remove and Install

#### REMOVE, DISCONNECT

1. Glove compartment (See Section C).
2. Remove rubber mat in front of function display
3. Unbolt function display
4. Press function display out of instrument panel from behind.

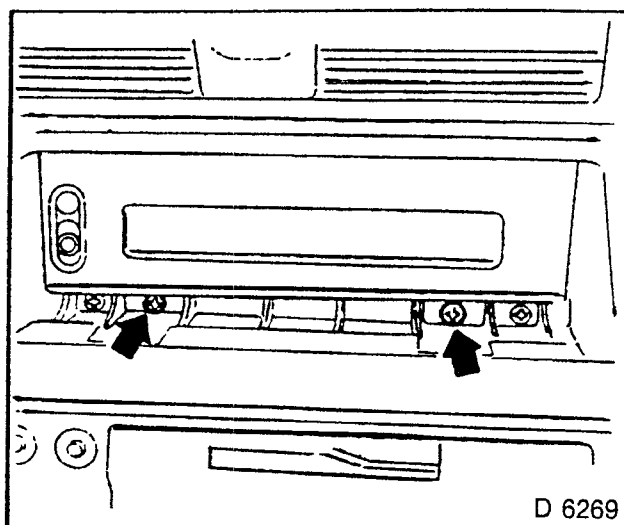


Fig. 77

5. Unlatch wiring harness plug and remove

#### INSTALL, CONNECT

1. Wiring harness plug
2. Function display.
3. Rubber mat.
4. Glove compartment.

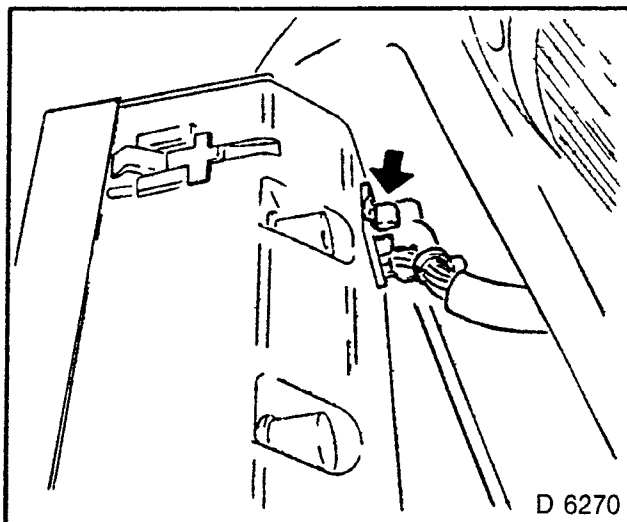


Fig. 78

### Coolant Residue Sensor — Replace

#### REMOVE, DISCONNECT

1. Wiring harness plug
2. Sensor from coolant fluid compensation tank.

#### INSTALL, CONNECT

1. Sensor.
2. Wiring harness plug.

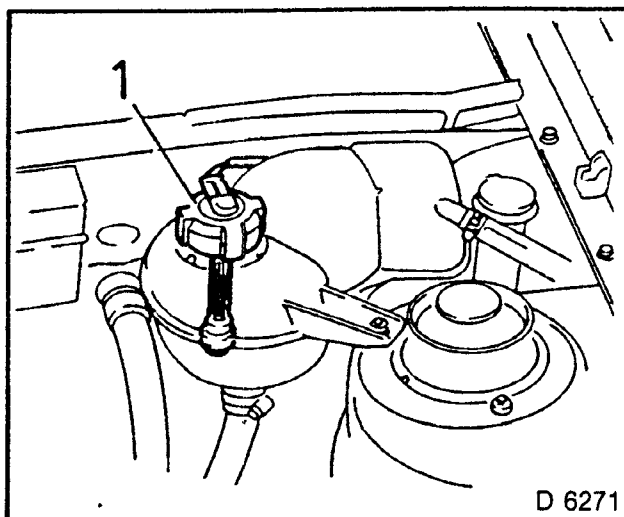


Fig. 79

## Cleaning Fluid Residue Sensor — Replace

**NOTE:**  
COLLECT ANY CLEANING FLUID WHICH MAY ESCAPE.

### REMOVE, DISCONNECT

1. Fluid reservoir.
2. Wiring harness plug.
3. Sensor from fluid reservoir

### INSTALL, CONNECT

1. Sensor.
2. Wiring harness plug.
3. Fluid reservoir, top up cleaning fluid.

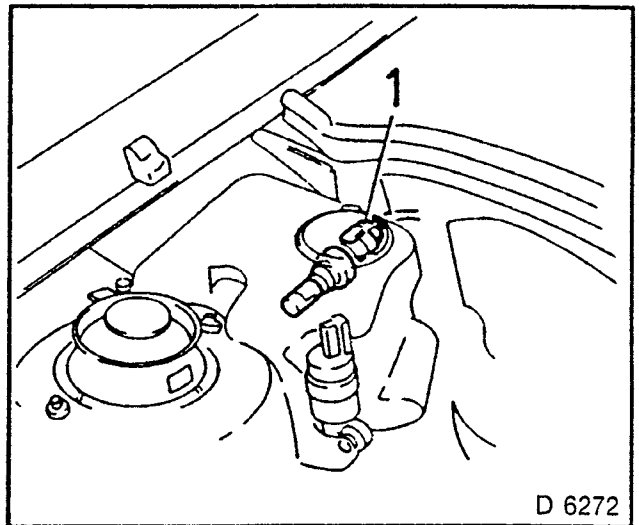


Fig. 80

## Engine Oil Residue Sensor — Replace

### REMOVE, DISCONNECT

1. Wiring harness plug from sensor.
2. Sensor from fluid pan.

### INSTALL, CONNECT

1. Sensor
2. Wiring harness plug.

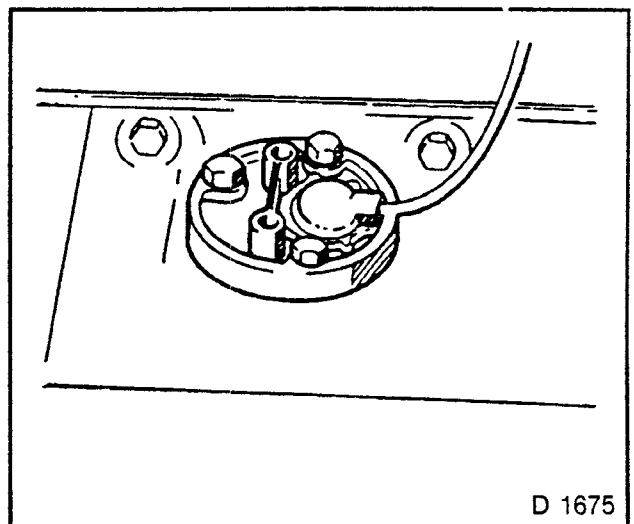


Fig. 81

## Outside Temperature Sensor — Replace

### REMOVE, DISCONNECT

- 1 Outside temperature sensor from front bumper.
2. Separate wiring harness plug.

### INSTALL, CONNECT

1. Outside temperature sensor.
- 2 Wiring harness plug.

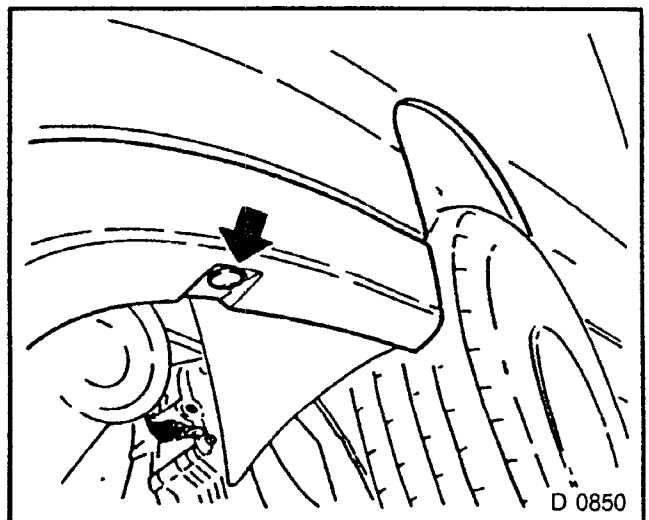


Fig. 82

## HEATED REAR SCREEN

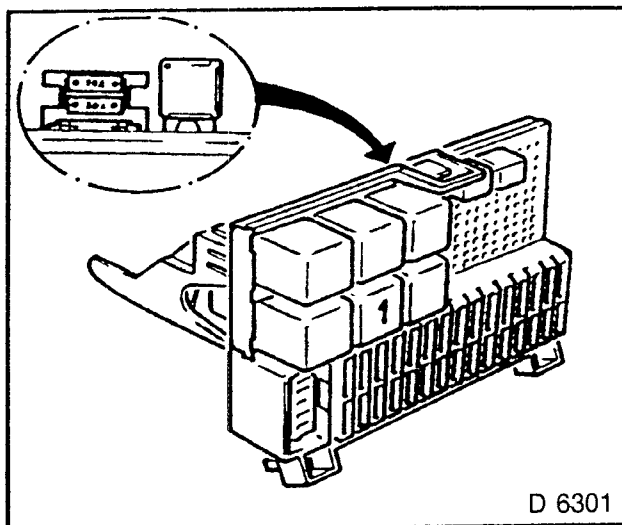
### Heated Rear Screen Relay — Replace

#### REMOVE, DISCONNECT

1. Cover from fuse box.
2. Remove relay (1) from socket

#### INSTALL, CONNECT

1. Insert relay in socket.
2. Secure fuse box.



D 6301

Fig. 83

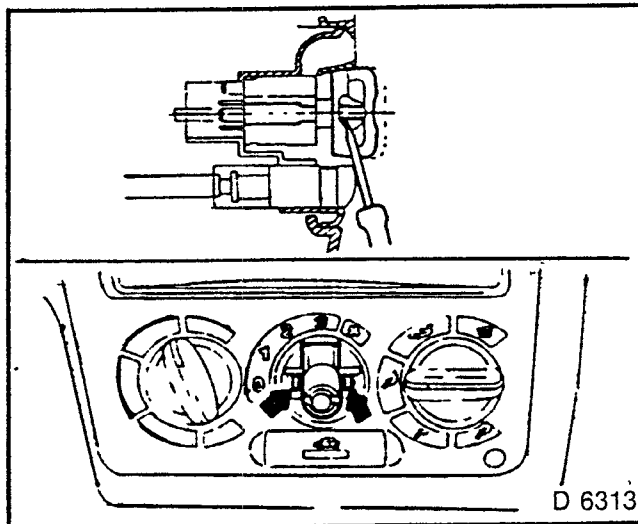
### Heated Rear Screen Switch — Remove and Install

#### REMOVE, DISCONNECT

1. Switch for heated rear screen in "ON" position.
2. Unlatch rotary knob and remove.
3. Unlatch switch for heated rear screen with a small screwdriver and remove from base

#### INSTALL, CONNECT

1. Heated rear screen switch.
2. Rotary knob.



D 6313

Fig. 84

## SCREEN WIPERS, SCREEN WASH/WIPE SYSTEM, HEADLAMP WASHER SYSTEM

### Windscreen Wiper Motor with Linkage — Remove and Install

#### REMOVE, DISCONNECT

1. Windscreen wiper arm, wind deflector (See Section A).
2. Detach wiring harness plug (1) and remove.
3. Unbolt motor with linkage (arrows).

#### INSTALL, CONNECT

1. Motor with linkage.
2. Wiring harness plug.
3. Wind deflector.
4. Windscreen wiper arm.

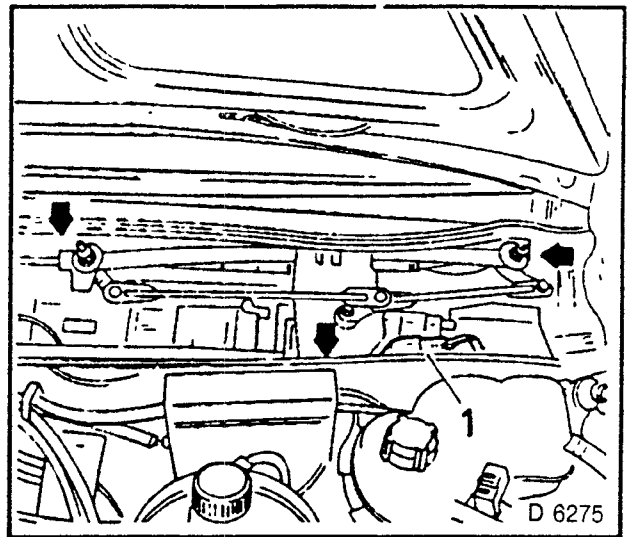


Fig 85

### Rear Screen Wiper Motor (Kadett) — Remove and Install

#### REMOVE, DISCONNECT

1. Unscrew screen wiper arm.
2. Nut from screen wiper cable.
3. Tailgate panelling (See section C)
4. Disconnect wiring harness plug and remove.
5. Unscrew motor from tailgate.

#### INSTALL, CONNECT

1. Bolt on motor with ground cable.
2. Wiring harness plug.
3. Tailgate panelling.
4. Nut on screen wiper cable.
5. Screen wiper arm.

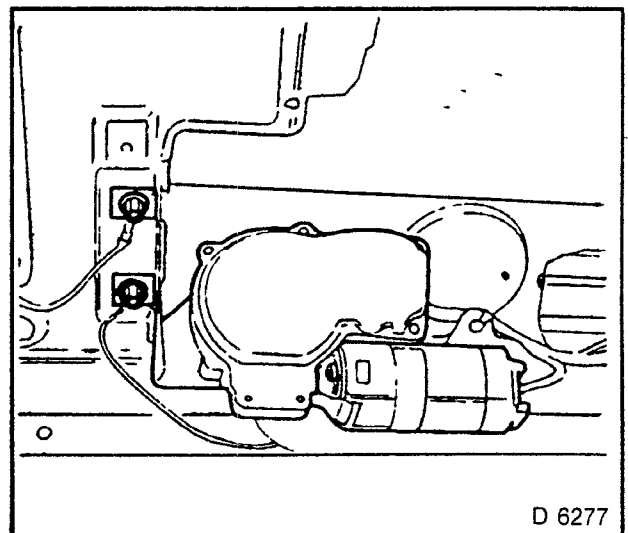


Fig. 86

## Interval Relay — Screen Wash/Wipe System — Replace

### REMOVE, DISCONNECT

1. Loosen fuse box.
2. Remove interval relay from socket.
  - 1 — Windscreen interval relay
  - 2 — Rear screen interval relay.

### INSTALL, CONNECT

1. Insert interval relay in socket.
2. Fasten fuse box

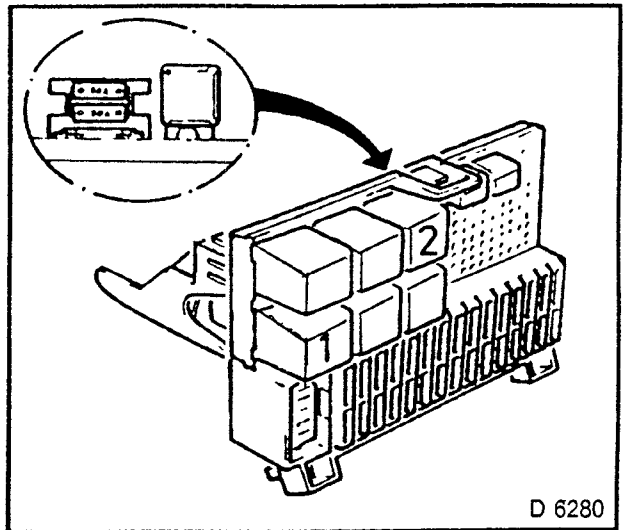


Fig 87

## Pump — Screen Wash/Wipe System — Remove and Install

**NOTE:**  
COLLECT ANY CLEANING FLUID WHICH MAY ESCAPE.

### REMOVE, DISCONNECT

1. Pull off wiring harness plug
2. Separate hoses (3).
3. Pump from reservoir (1 + 2).

### INSTALL, CONNECT

1. Pump.
2. Hoses.
3. Wiring harness plug

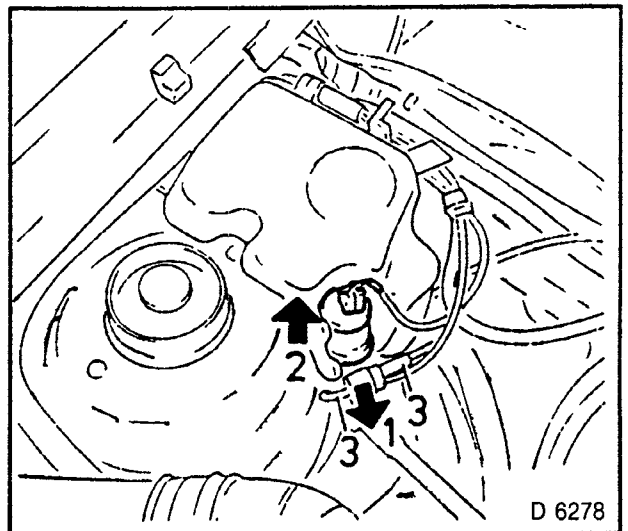


Fig. 88

## Wash/Wipe System Reservoir — Remove and Install

### REMOVE, DISCONNECT

1. Unbolt wiring harness plug.
2. Hoses.
3. Pump (1, 2)
4. Fluid reservoir (3)  
Pull from bracket.

### INSTALL, CONNECT

1. Fluid reservoir.
2. Pump
3. Hoses.
4. Wiring harness plug.

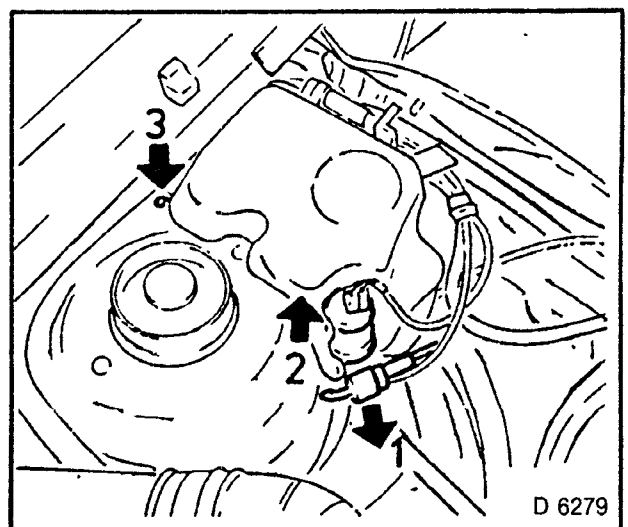


Fig. 89



## ELECTRONICALLY OPERATED WINDOW WINDERS

### Operating Switch (Driver's Door) — Remove and Install

#### REMOVE, DISCONNECT

1. Inner door trim (See Section C).
2. Detach wiring harness plug and remove.
3. Carefully lever out operating switch from inner door trim.

#### INSTALL, CONNECT

1. Operating switch.
2. Wiring harness plug.
3. Inner door trim.

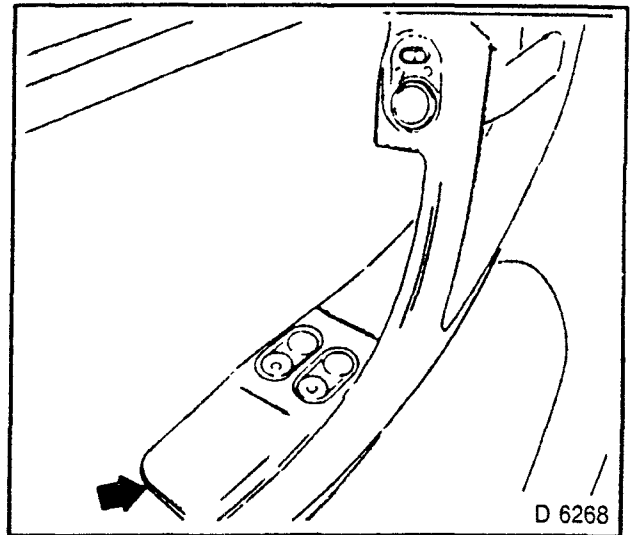


Fig. 90

### Operating Switch (Passenger Door) — Remove and Install

#### REMOVE, DISCONNECT

- 1 Carefully lever operating switch out of door inner panelling.
2. Door inner panelling (See Section C).
- 3 Disconnect wiring harness plug and remove
4. Operating switch with wiring harness from door inner panelling

#### INSTALL, CONNECT

1. Wiring harness plug.
- 2 Door inner panelling.
3. Operating switch.



## *Gas Analysis*

### *Diagnosics using a 4 Gas Analyser*

Before attempting to perform any diagnostics using a 4 gas analyser, it is important to understand the equipment and the results obtained.

We shall begin with explaining the different gases tested :

#### Hydrocarbons (HC)

Hydrocarbons are unburned or partially burnt fuel particles. High levels of HC, measured in PPM (parts per million) in the exhaust gases, is usually due to malfunctions in the ignition or fuel systems.

#### Carbon Monoxide (CO)

Carbon monoxide is formed when there is insufficient oxygen present during combustion and is measured as a percentage of exhaust gases. (CO - one part carbon to one part oxygen) The most common cause of high CO is incorrect adjustment of fuel mixtures. Refer to the relevant manufacturers manuals for correct setting procedures.

#### Carbon Dioxide CO<sub>2</sub>

CO<sub>2</sub> - one part carbon to two parts oxygen. The greater the percentage of CO<sub>2</sub> in the exhaust gases, the more efficient the running of the engine, ideal specification for a 4 cylinder engine is between 13 and 16 %. If the CO<sub>2</sub> level dropped too low, this would indicate an incorrect air fuel mixture either caused by malfunctions in the management system or incorrect adjustments.

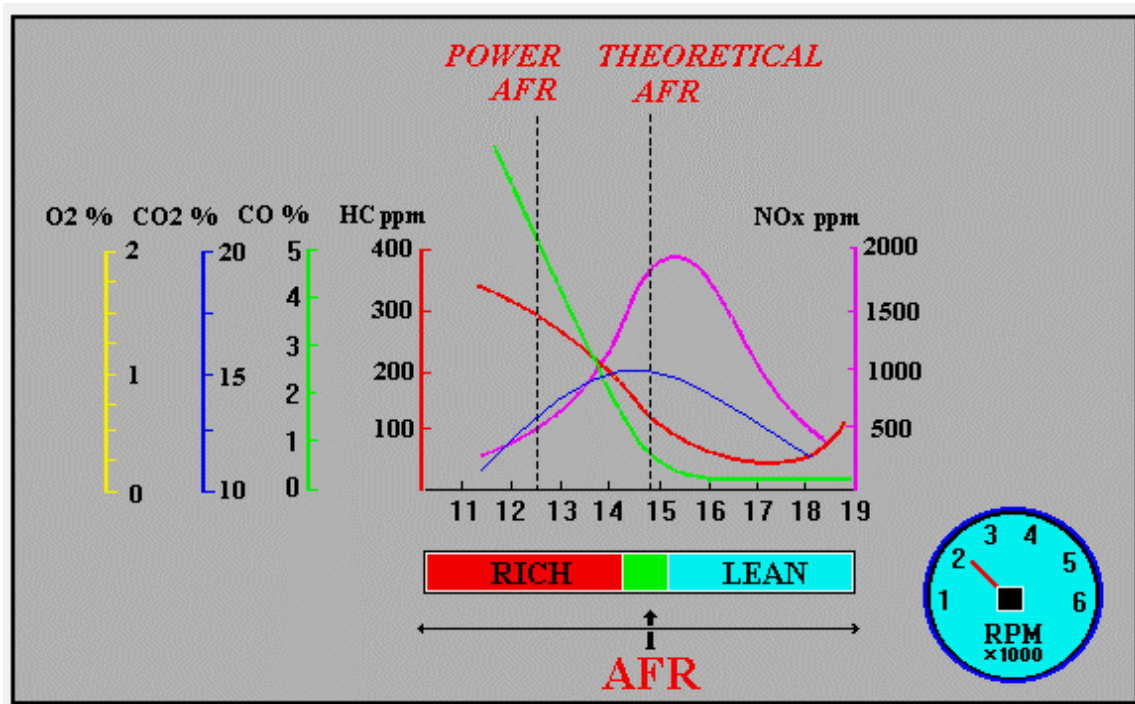
#### Oxygen (O<sub>2</sub>)

Oxygen is measured as a percentage of the exhaust gases and should be between 1 - 1.5% indicating an efficient combustion and air fuel mixture. Whilst adjustments are being performed, it is important to note the changes in O<sub>2</sub>, as a sharp change of between 0.5 - 1.0 % and 1.0 - 0.5 % will indicate the cross-over point from a rich or lean mixture respectively. O<sub>2</sub> measurement is also useful in detecting leaks and misfiring as well as the efficiency of combustion.

#### Oxides of Nitrogen (Nox)

Engines use O<sub>2</sub> in the combustion process and exhaust Nitrogen (N<sub>2</sub>). This exhausted N<sub>2</sub> is exposed to high temperatures during the combustion process and is converted to Oxides of Nitrogen (NO<sub>x</sub>) when that temperature exceeds approx. 1370 degrees Celsius. Although NO<sub>x</sub> compounds do not directly affect the efficiency of an engine, they are responsible for smog when combined with HC. Part of the solution to minimise NO<sub>x</sub> is the catalytic converter and the exhaust gas recirculation process.

# Air: Fuel Ratio and Gas Emission Theory



## HC and CO Analysis

### Hydrocarbons

The ignition of the air : fuel mixture in the combustion chamber does not result in all the fuel being burned, hence the HC emission. Should there be any malfunction in the system the quantity of Hc will increase.

Normal **HC readings range between 0 – 350 PPM**, depending on the age and condition of the vehicle. Low HC readings indicate that most of the fuel is being burned, and high HC readings indicate a higher quantity of unburned fuel.

### Carbon Monoxide

As the air : fuel mixture is ignited, the resulting combustion process produces some CO as a normal condition. However, if the air : fuel mixture is incorrect, there will be a larger amount of HC, which will increase the CO, resulting in air pollution and reduced engine efficiency. Normal idle **CO for vehicles with the Motronic 1.5.4 systems is 1 – 1.5 %**. Idle CO can vary depending on the management system and can range from 0 to 3 %

# CO2 and O2 Analysis

## Carbon Dioxide

Carbon dioxide is a product of combustion. A normal functioning engine should produce between 13 and 16 % of CO2. If combustion was incomplete or the air : fuel ratio was incorrect, the quantity of CO2 produced will be minimised resulting in a less efficient engine. Any dilution of the exhaust gases (secondary air pumps, etc.) will result in a drop in CO2 content.

## Oxygen

The engine inducts approx. 20.7% oxygen, 78% Nitrogen and 0.5 – 2.0% other gases. During combustion, most of the oxygen is consumed, and if the engine is running correctly, 0.5 – 2.0% is exhausted. Any more than the 2% oxygen exhausted is valuable diagnostic information to the technician.

Low O2 levels indicate a rich mixture. (A rich mixture will consume more or all of the available oxygen during combustion). 0% oxygen indicates that all oxygen was consumed during combustion, resulting in unburned fuel.

High O2 levels indicate an incomplete combustion process. (Not enough oxygen was utilised during combustion, resulting in unburned fuel)

| NORMAL | IDLE      | 2500 RPM  |
|--------|-----------|-----------|
| HC ppm | 75 - 250  | 25 - 150  |
| CO %   | 0.5 - 3.0 | 0.1 - 1.5 |
| CO2 %  | 10 - 14   | 13 - 15   |
| O2%    | 0.1 - 2.0 | 0.1 - 2.0 |



| RICH   | IDLE     | 2500 RPM |
|--------|----------|----------|
| HC ppm | 50 - 250 | 0 - 150  |
| CO %   | > 3.0    | > 3.0    |
| CO2 %  | 8 - 10   | 9 - 11   |
| O2%    | 0 - 0.5  | 0 - 0.5  |

| LEAN   | IDLE      | 2500 RPM |
|--------|-----------|----------|
| HC ppm | 75 - 250  | 0 - 100  |
| CO %   | 0 - 1.0   | 0 - 0.75 |
| CO2 %  | 8 - 10    | 9 - 11   |
| O2%    | 1.5 - 3.0 | 1 - 2.0  |

| LEAN MISFIRE | IDLE       | 2500 RPM   |
|--------------|------------|------------|
| HC ppm       | 400 - 1200 | 400 - 1200 |
| CO %         | 0 - 0.75   | 0 - 0.75   |
| CO2 %        | 5 - 9      | 6 - 10     |
| O2%          | 4 - 9      | 2 - 7      |

| MISFIRE | IDLE      | 2500 RPM  |
|---------|-----------|-----------|
| HC ppm  | > 1000    | > 1000    |
| CO %    | 0.5 - 3.0 | 0.1 - 1.5 |
| CO2 %   | 6 - 8     | 8 - 10    |
| O2%     | 5 - 12    | 5 - 12    |

# *Diagnostics*

## Condition

## Possible Cause

(Conventional and Electronic Management Systems)

### **RICH MIXTURE**

IDLE MIXTURE TOO RICH  
FLOAT LEVEL TOO HIGH  
BLOCKED AIR CLEANER  
CONTAMINATED CRANKCASE OIL  
PVC RESTRICTED  
POWER VALVE LEAKING  
CHOKE SETTING

LOW IDLE SETTING  
BLOCKED CARBURETTOR AIR BLEEDS  
INCORRECT IGNITION TIMING ( IDLE )  
SATURATED CARBON CANISTER  
FUEL PRESSURE HIGH ( EFI )  
LEAKING INJECTORS ( EFI )  
ENGINE MANAGEMENT FAULT ( EFI )

### **LEAN MIXTURE**

CRACKED VACUUM LINES  
DISCONNECTED VACUUM LINES  
SMALL AIR LEAKS  
LOW FLOAT LEVEL  
CRUISE MIXTURE LEAN  
EXHAUST LEAKS  
INLET LEAKS

EGR VALVE MALFUNCTION  
LOW FUEL PRESSURE  
LOW FUEL FLOW  
IDLE MIXTURE LEAN  
AIR INJECTION ACTIVE  
BLOCKED INJECTORS ( EFI )  
ENGINE MANAGEMENT FAULT ( EFI )

### **LEAN MISFIRE**

MISADJUSTED CARBURETTOR  
SEVERE AIR LEAKS  
STUCK PVC  
FAULTY PLUGS  
FAULTY PLUG LEADS

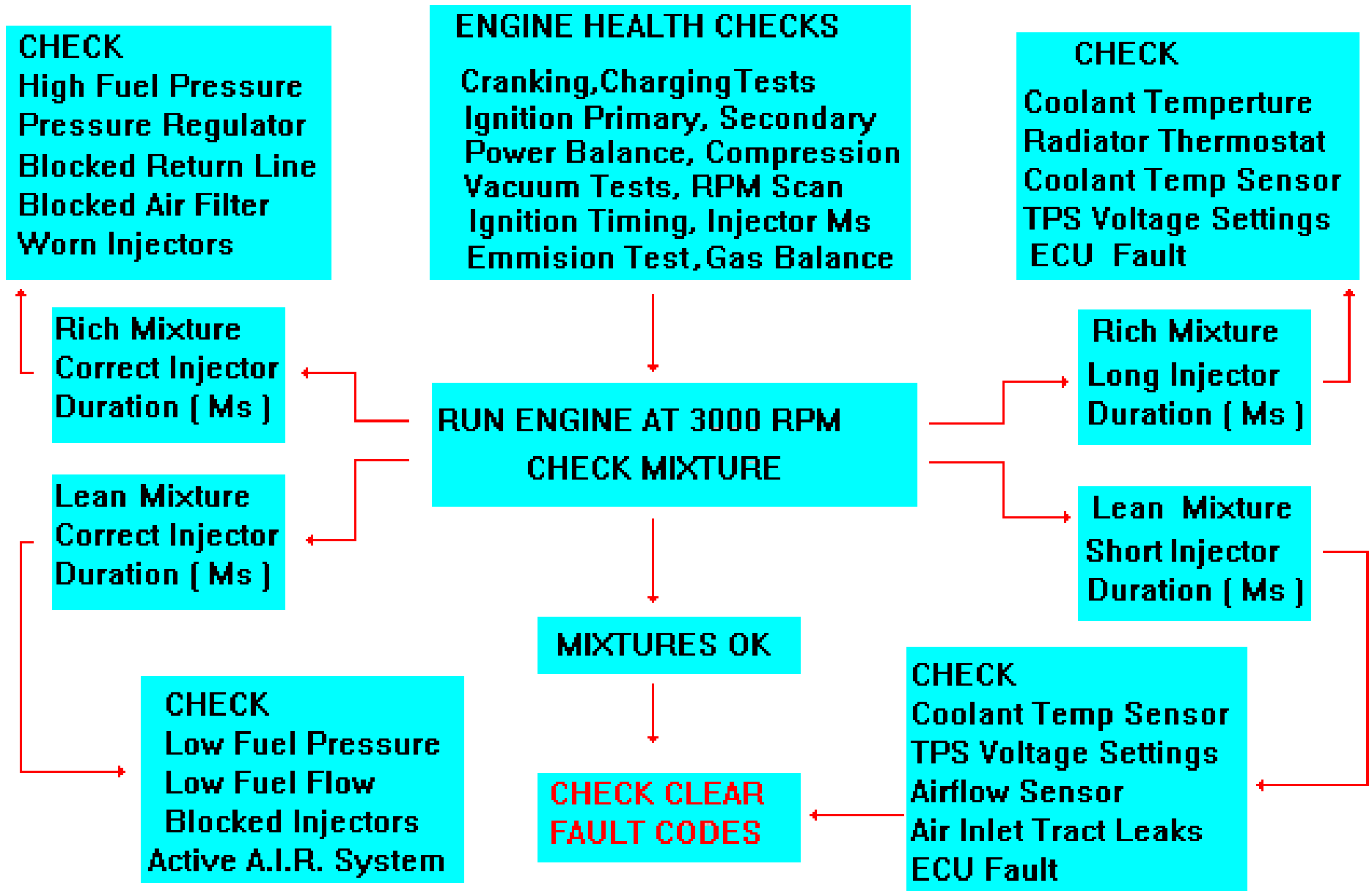
LOW COMPRESSION  
EGR VALVE MALFUNCTION  
BLOCKED INJECTORS ( EFI )  
ENGINE MANAGEMENT FAULT ( EFI )

### **MISFIRE**

FOULED SPARK PLUG  
OPEN SPARK PLUG LEAD  
GROUNDED SPARK PLUG LEAD  
OVER ADVANCED IGNITION TIMING  
LOW IGNITION ENERGY

LOW COMPRESSION  
LEAKING HEAD GASKET  
INCORRECT VALVE ADJUSTMENT  
EGR FROZEN OPEN  
ENGINE MANAGEMENT FAULT ( EFI )

# EFI ENGINE FAULT FINDING CHART





# Injection Systems

## Multi Point

- Simultaneous** Injectors receive pulses from E.C.U. twice per engine cycle. ( Corsa 13 NE, 16NE, Astra 14SE, 16SE, 18XE, 20SHE )
- Sequential** Injectors are pulsed by E.C.U. once per engine cycle as per spark plug firing order. ( Astra 20XE )
- Grouped** Injectors pulsed in groups or banks, once or twice per cycle depending on system design

## Single Point

- Throttle Body** Single injector mounted on throttle body pulsed as per engine requirement ( Astra 160 TBI )

## Operation

Injectors on the Bosch Motronic engine management systems receive battery voltage and are triggered by the E.C.U. depending on the signals received from the various sensors attached to the engine. Fuel pressure is constant (M.P.F.I. – 250 to 300 Kpa).

Injector opening frequency (Hz) and duration (pulse width) determine the amount of fuel being delivered to the combustion chamber. Variations in pulse width and frequency ensure that adequate fuel is supplied for efficient engine operation.

**LONGER PULSE WIDTH = RICHER MIXTURE**  
**SHORTER PULSE WIDTH = LEANER MIXTURE**

Pulse rate and width will increase with increased engine rpm and load.

## Duty Cycle

Duty cycle is the combination of pulse width and pulse rate, and is expressed as a percentage of time “ON” and time “OFF” – eg. If an injector was on for 10ms and closed for 90ms, the duty cycle “ON” is 10% and the duty cycle “OFF” is 90%. The total on and off duty cycle reading should be 100%.

Cranking Injector duration is longer during cranking (richer mixture) for easier starting and to promote warm-up.

Idling Injector duration is longer at start-up if engine is cold, and gradually decreases as engine warms up.

Acceleration Injector duration is longer at initial acceleration to prevent “flat spot”

Running Injection pulse is controlled by the E.C.U. depending on the signals received from the various engine sensors.

## TESTING INFORMATION AND TEST PROCEDURES

### Typical Simultaneous Injection Duration

| Engine Cold          | Ms       |
|----------------------|----------|
| Cranking -----       | >4       |
| Idle -----           | 3.5 to 4 |
| <b>Engine Warm</b>   |          |
| Idle -----           | 2.5      |
| 1000rpm -----        | 2.3*     |
| 2000 -----           | 2.1*     |
| 3000 -----           | 2.0*     |
| <b>Snap Throttle</b> | >7       |

\* Gradually leans out, depending on load

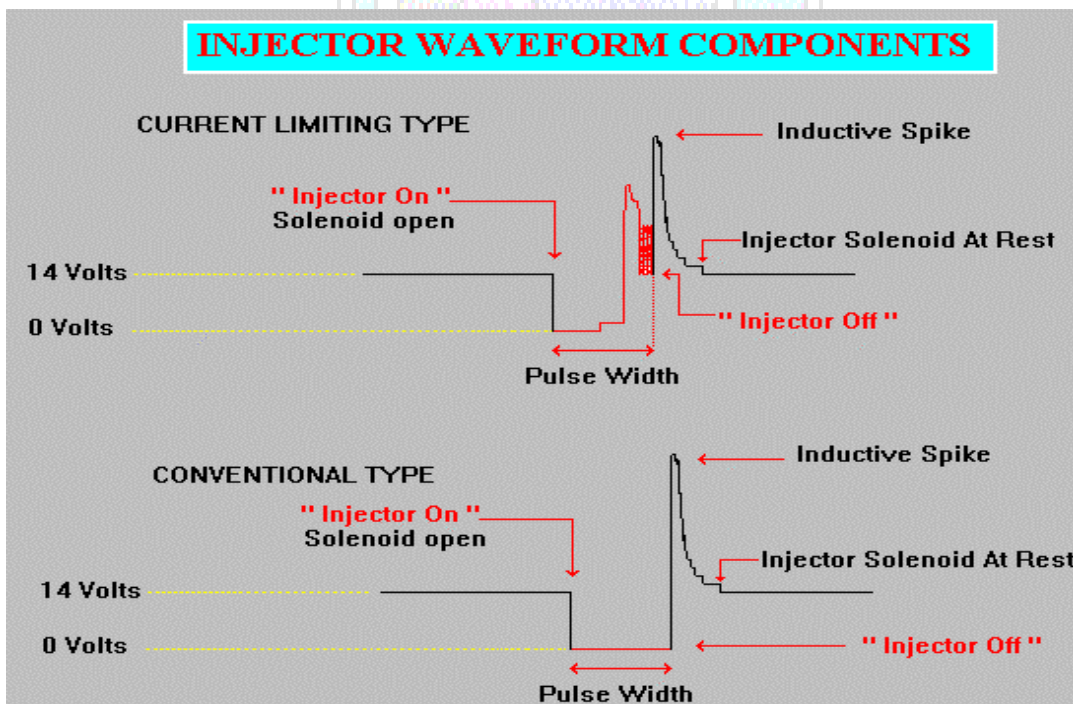
**Sequential injection systems will be less than twice the above values due to single pulsing per engine cycle.**

### NOTES.

***THE USE OF A 4 GAS ANALYSER CAN GREATLY AID DIAGNOSTIC DIRECTION AND TIME.***

*Comparing mixture content to injector pulse width can identify components and systems to be tested in a logical sequence.*

Example : A rich mixture could indicate high fuel pressure, incorrect manifold pressure, incorrect coolant temp, etc,etc.





**DUPEC ELECTRONICS (PTY) LTD**

**DEFITA200**

**MICROCONTROLLER BASED**

**FUEL INJECTION AND**

**SPARK TIMING SYSTEM**

**AND INTERFACE**

**SPECIFICATION**

**TRAINING MANUAL**

**93/5**

# **CONTENTS**

- 1.0 PRODUCT DESCRIPTION**
- 2.0 FEATURES**
- 3.0 PRODUCT IDENTIFICATION AND APPLICATION**
- 4.0 SPECIFICATION**
  - 4.1 Electrical**
  - 4.2 Environmental**
  - 4.3 Fuel delivery**
- 5.0 CONNECTIONS**
- 6.0 SPARK TIMING**
  - 6.1 Distributor bypass operation**
  - 6.2 Engine speed and crankshaft position measurement**
  - 6.3 Engine load measurement**
  - 6.4 Advance angle look-up**
  - 6.5 Ignition firing delay calculation**
  - 6.6 Dwell time calculation**
  - 6.7 Engine water temperature measurement**
- 7.0 FUEL INJECTION**
  - 7.1 Air mass to fuel mass ratio**
  - 7.2 Air mass measurement**
  - 7.3 Speed density concept**
  - 7.4 Fuel metering**
  - 7.5 Continuous fuel flow rate**
  - 7.6 Injector opening and closing times**
  - 7.7 Injection timing**
  - 7.8 Injection duration**
  - 7.9 Correction factors**
    - 7.9.1 Injection hardware deficiencies**
    - 7.9.2 Engine operating conditions**
    - 7.9.3 Intake air temperature**
    - 7.9.4 Engine temperature**
    - 7.9.5 Cold starting conditions**
    - 7.9.6 Post-start and warm-up conditions**
    - 7.9.7 Acceleration conditions**
    - 7.9.8 Deceleration lean-out conditions**

- 7.9.9 Coasting conditions**
- 7.9.10 Flooded engine conditions**
- 7.9.11 Full load operation**
- 8.0 IDLE SPEED**
- 9.0 IMMOBILISER OPERATION**
- 10.0 DEFAULT MODE SELECTION**
- 11.0 DIAGNOSTICS**
  - 11.1 Diagnostic codes**
  - 11.2 Volt- and ohmmeter**
    - 11.2.1 Battery voltage**
    - 11.2.2 Ignition voltage**
    - 11.2.3 TPS supply voltage**
    - 11.2.4 TPS input signal voltage**
    - 11.2.5 CO potentiometer supply voltage**
    - 11.2.6 MAP sensor supply voltage**
    - 11.2.7 MAP sensor signal voltage**
    - 11.2.8 Timing map selector**
    - 11.2.9 Fuel mixture selector**
    - 11.2.10 EWT sensor**
    - 11.2.11 MAT sensor**
  - 11.3 Fault finding**
  - 11.4 D-TEQ200 PC based tester**
    - 11.4.1 Description**
    - 11.4.2 Installation**
    - 11.4.3 Operation**
  - 11.5 C-TEQ200 component tester**
    - 11.5.1 Description**
    - 11.5.2 Operation**

# **1 PRODUCT DESCRIPTION**

The DEFITA200 range of ECU's (Engine Control Units) is microcontroller based and controls the spark timing, fuel injection and certain other functions of internal combustion engines electronically, thus ensuring optimum operating efficiency.

DEFITA200 is an abbreviation for Dupec Electronic Fuel Injection and Timing Advance.

## **2 FEATURES**

The DEFITA200 range of ECU's is designed, developed and manufactured in the Republic of South Africa and offers the following features:

**Standard functions:**

- Spark timing up to 7,810 r.p.m. on 4 cylinder engines
- Spark timing based on engine load, temperature crankshaft position/speed and battery voltage
- Automatic altitude compensation by measurement of manifold absolute pressure
- Fuel injection based on engine load, speed, temperature and manifold air temperature
- Coasting fuel cut-off
- Pre-programmed rev. limiting by fuel cut-off
- Active idle speed control

- **User selectable spark timing curves for different fuel octane ratings**
- **User selectable fuel mixture maps for different octane ratings**
- **Automatic default mode selection in the event of sensor failure allows limp-home operation**
- **Air-conditioner shutdown control**
- **Self-diagnostics with fault storage**
- **Intelligent PC based diagnostics with logging facility.**
- **Software immobiliser which prevents hot-wiring**
- **Repairability. THIS IS NOT A THROW-AWAY UNIT. IT CAN BE REPAIRED AT DUPEC FOR A MINIMAL CHARGE**

### **3 PRODUCT IDENTIFICATION AND APPLICATION**

**The product is identified by a white label on its lid having the following information. (P/N93593652 supersedes 93591117)**

**DEFITA200  
160 TBi  
MODEL NO.: A020-C  
DMC P/N: 93593652  
MADE IN R.S.A.**

## 4 SPECIFICATION

The following specification is applicable to DEFITA200 P/N: A020-C ECU's unless otherwise stated:

### 4.1 Electrical

Operating voltage : 9 to 15 VDC continuous  
: 6 to 16 VDC limited functions  
: 24 VDC for 60 seconds maximum

Operating current : Less than 500 mA

Standby current : Less than 12 mA (>1 minute after ignition off)

Timing accuracy : +/- 0.5 degrees

R.p.m. limit : 6,297

Reference signal : Negative edge from Distributor Y24 at 10° BTDC

Base timing : 10° BTDC  
r.p.m. < 450 or diagnostics initialised after starting

Mapped timing : r.p.m. > 450 and diagnostics disabled

Selectable octane maps : 97 RON Factory fitted  
: 93 RON  
: 87 RON  
: 87D RON (For fuel with octane below 87 RON)

Selectable by interchanging octane plug on harness

**Fuel mixture adjustment : - 15% Leaner**

**: - 10% Leaner**

**: - 05% Leaner**

**: + 05% Richer**

**: + 10% Richer**

**: + 15% Richer**

**: + 20% Richer**

**: + 25% Richer**

**Selectable by installing optional  
mixture selection plug.**

**Operation only possible in open  
throttle position.**

**Air-conditioner shut-off : Throttle > 88% open OR**

**: TPS closed and speed < idle r.p.m.**

**Fuel injection timing : Synchronous with reference signal**

**Idle CO adjustment : +/- 15% of base fuel map by means  
of CO potentiometer with closed  
throttle**

**Coasting cut-out : 1228 r.p.m. - EWT > 78 °C**

**: 1755 r.p.m. - EWT = 0 °C**

**Idle speed : 910 r.p.m. - EWT > 78 °C**

**: 1300 r.p.m. - EWT = 0 °C**

**: 1050 r.p.m. - A/C ON (EWT > 78 °C)**

**: 1495 r.p.m. - A/C ON (EWT = 0 °C)**

**Idle speed control : By means of stepper motor control  
of IACV (Idle Air Control Valve)**

**Wide Open Throttle (WOT) : Throttle > 72% open**

**Flood compensation : 0.6x base fuel maps in WOT mode  
and r.p.m. < 450**



**Fuel pump prime time : 2 +/- 0.2 seconds**

**Immobiliser arming : Automatic; de-arming after successful communication with the ACU**

**Protection : All input and output terminals are protected against accidental shorts to ground or battery voltage except the following**  
:- diagnostic lamp to 12 volt  
- coil drive to 12 volt

**Default mode selection : Automatic in the event of a sensor failure**

**Diagnostics initialisation : Short line on ALDL plug to ground before starting engine**

**Diagnostics : Tell tale lamp**  
: D-TEQ200 PC based intelligent system  
: C-TEQ200 Component tester

## **4.2 Environmental**

**Operating temperature : -25ø to +85ø Celsius**

**Water resistance : Splash proof**

## **4.3 Fuel delivery**

**Pump : AC Rochester pump fitted in the fuel tank. P/N**

**Fuel pressure : 100 kPa**

## 5 CONNECTIONS

All input and output connections are made via a 48-pin AMP connector.

| <b>TERMINAL NO.</b> | <b>DESIGNATION</b>                   |
|---------------------|--------------------------------------|
| 01A                 | - NC (no connection)                 |
| 02A                 | - NC                                 |
| 03A                 | - NC                                 |
| 04A                 | - NC                                 |
| 05A                 | - NC                                 |
| 06A                 | - Diagnostics initialise input       |
| 07A                 | - A/C switch input signal            |
| 08A                 | - A/C clutch input signal (not used) |
| 09A                 | - Rev. counter output signal         |
| 10A                 | - Diagnostic lamp output signal      |
| 11A                 | - Sensor/signal ground connection    |
| 12A                 | - Sensor/signal ground connection    |
| 13A                 | - NC                                 |
| 14A                 | - NC                                 |
| 15A                 | - NC                                 |
| 16A                 | - Diagnostic output signal to D-Teq  |
| 17A                 | - Sensor/signal ground connection    |
| 18A                 | - Diagnostic input signal from D-Teq |
| 19A                 | - Immobiliser output signal          |
| 20A                 | - Sensor/signal ground connection    |
| 21A                 | - Immobiliser input signal           |
| 22A                 | - Sensor/signal ground connection    |

- 01B - Phase 1D drive signal to stepper motor terminal D**
- 02B - Phase 1C drive signal to stepper motor terminal C**
- 03B - Phase 2B drive signal to stepper motor terminal B**
- 04B - Phase 2A drive signal to stepper motor terminal A**
- 05B - TPS input signal from terminal C**
- 06B - Bypass signal to distributor terminal C**
- 07B - Coil driver output signal to distributor terminal A**
- 08B - Reference signal input from distributor terminal B**
- 09B - 5V output to TPS terminal A**
- 10B - A/C relay output signal**
- 11B - Fuel pump relay output**
- 12B - Power ground connection**
- 13B - Injector drive output signal**
- 14B - Sensor/signal ground connection**
- 15B - MAP sensor signal input from terminal B**
- 16B - EWT signal input**
- 17B - MAT signal input**
- 18B - Fuel map selection input**
- 19B - Timing map selection input**
- 20B - CO mixture adjust input signal**
- 21B - Sensor/signal ground connection**
- 22B - Ignition voltage input**
- 23B - 5V output to CO adjustment potentiometer**
- 24B - 5V output to MAP sensor terminal C**
- 25B - Power ground connection**
- 26B - Battery voltage input**

## **6 SPARK TIMING**

**Spark timing and fuel injection for DEFITA200 ECU's is calculated by a central processing unit and are based on:**

- I - MAP**
- II - EWT**
- III - Battery voltage**
- IV - Crankshaft position**
- V - Engine speed**
- VI - Throttle position**

**The optimum timing advance curves for a given engine are determined by running the engine on an engine dynamometer under any combination of the above-mentioned conditions. This process is known as mapping the engine. The mapping is further refined by extensive driving tests.**

**The mapped data regarding the engine is stored in a ROM (Read Only Memory) within the ECU.**

**The following processes take place when calculating the advance angle:**

- I - engine speed and crankshaft position measurement**
- II - engine load measurement**
- III - advance angle look-up**
- IV - ignition firing delay calculation**

## **6.1 Distributor bypass operation**

At engine speeds below 450 r.p.m. the ECU does not control the firing angle. The ECU keeps the bypass line to terminal C of the distributor low for engine speeds below 450 r.p.m. The spark advance for the vehicle is set to 10° BTDC by the distributor, while the engine speed is below 450 r.p.m.. Above 450 r.p.m. the ECU takes the bypass line high (+5 volt) and takes over control of the spark advance as described below.

## **6.2 Engine speed and crankshaft position measurement**

Engine speed is calculated by measuring the period from one negative edge to the next negative edge of the distributor reference signal. The reference signals are separated by 180 degrees.

The distributor generates a signal as shown in the reference and ignition waveform diagram. The time taken for the crankshaft to rotate from 10° BTDC to the next 10° BTDC marker is measured. Knowing the time it takes the crankshaft to rotate through 180° it is possible to calculate the current engine speed in degrees per second (°/s). Crankshaft position is obtained by sensing the falling edges of the reference signal.

## **6.3 Engine load measurement**

**Engine load is measured by an external MAP ( Manifold Absolute Pressure) sensor. Absolute pressure measurement automatically adjust spark timing for altitude changes. It is also required to determine the air mass for fuel injection applications.**

## **6.4 Advance angle look-up**

**The optimum advance angle obtained by mapping the engine is stored in a matrix (table) having 10 load and 62 r.p.m. sites. There are thus 620 possible advance angles stored in ROM for every RON number used. The CPU (Central Processing Unit) compares the calculated engine speed and measured load with the site indexes stored in ROM. If an exact corresponding speed and load site are found it uses the corresponding advance angle in the matrix. In cases where exact corresponding load and r.p.m. sites are not found the CPU uses linear interpolation to calculate the corresponding advance angle to be used.**

## 6.5 Ignition firing delay calculation

The advance angle obtained from the look-up matrix is subtracted from the 10° BTDC marker on the distributor shaft to obtain the firing angle delay.

Example: Advance angle = -20° on next cycle  
Marker position = -10°  
Firing angle delay = 180° - (-10°) - 20°  
= 170° delay

Having determined the engine speed previously in degrees per second it is now possible to calculate the delay time after the BTDC marker that corresponds with the required advance angle.

Example: Crankshaft speed = 5,400 r.p.m.  
Distributor speed = 2,700 r.p.m.  
= 2,700 / 60 r.p.s.  
= 45 r.p.s.  
= 45 x 360 °/s  
Crankshaft speed = 2 x 45 x 360 °/s  
= 30,400 °/s  
170° rotation delay = 170 / 30,400 s  
= 5.59 milli-second delay

## **6.6 Dwell time calculation**

**Dwell time is the time during which the battery voltage must be applied to the ignition coil's primary winding prior to an ignition pulse. The correct dwell time is important to ensure constant spark energy.**

**The correct dwell time depends on the battery voltage. A look-up matrix contains dwell time versus battery voltage. The prevailing battery voltage is measured and compared with the voltages stored in the dwell look-up matrix. The corresponding dwell time is used to energise the ignition coil.**

## **6.7 Engine water temperature measurement**

**EWT measurement is accomplished by a NTC (Negative Temperature Coefficient) sensor mounted on the engine block.**

**The base advance angles are increased with decreasing engine temperatures. This is necessary because it takes longer to reach maximum cylinder pressure after ignition when an engine is cold. Typical additional advance required for an engine at -20ø Celsius ranges from 3ø to 8ø with respect to an engine operating at 100ø Celsius.**



## **7 FUEL INJECTION**

**It is the function of any fuel injection system to ensure that the correct mass ratio of air and fuel is delivered to the engine under all operating conditions. We will concentrate on TBI (Throttle Body Injection or alternatively called single point fuel injection systems) in this document.**

**The availability of powerful low cost microprocessors has made it possible to fit FI (Fuel Injection) systems to a larger percentage of vehicles. The ECU (Engine Control Unit) evaluates input sensor data and calculates the required output signals to control the engine. The most important function of a FI system is to measure the air mass entering the engine and calculate the injector opening duration to ensure the correct A/F ratio under specific engine operating conditions. The A/F ratio has a direct effect on the power output of the engine, fuel consumption and exhaust gas emissions. It is therefore necessary to exercise precise control over the opening duration of the injector.**

**A number of operating conditions exist where the A/F ratio is deliberately modified and forced to deviate from the calculated ratio to ensure better drivability and smoother engine operation. These deviations are classified as A/F corrections and will later be examined in detail in this document.**

## 7.1 AIR MASS TO FUEL MASS RATIO

The theoretical air mass to fuel mass ratio required by an internal-combustion engine for complete combustion is 14.7:1. This ratio is also called the stoichiometric ratio. The A/F ratio determines the fuel consumption, maximum engine power output and exhaust gas emission levels. Unfortunately there is no single A/F ratio that optimises these three requirements.

The ratio of actual air mass supplied to the engine divided by the theoretical requirement is defined as lambda.

$\lambda$  = Air mass supplied/theoretical requirement

Where  $\lambda$  = Lambda

$\lambda = 1$

The air mass supplied matches the theoretical amount.

$\lambda < 1$

A lack of air resulting in a rich mixture. Increased engine power outputs are obtained for  $0.85 < \lambda < 1$ .

$0.75 < \lambda < 0.85$

A rich mixture suitable for transient conditions where a sudden load change is experienced.

$\lambda > 1$

An excess of air resulting in a lean mixture together with a reduction in engine power output. Optimum fuel consumption takes place with  $1 < \lambda < 1.2$ .

$\lambda > 1.3$

Lean mixture making it impossible to achieve reliable ignition.

## **7.2 AIR MASS MEASUREMENT**

**As we have seen previously the principle of fuel injection is based on measuring the air mass entering the engine and calculating the fuel mass required to obtain an A/F ratio of 14.7:1. A number of possible methods exist for measuring the air mass, but only the speed-density method used for this TBI system will be described in detail.**

**Some of the possible methods are:**

- a) Speed-density**
- b) Throttle butterfly angle**
- c) Flap or vane type**
- d) Hot-wire meter**
- e) Hot-film meter**
- f) Karman vortex ultrasonic meter.**

### **7.3 SPEED DENSITY CONCEPT**

If we know the density of the air inside a container it is possible to calculate the exact mass of the air inside the container.

$A_m = V_a \cdot \rho$  Where  $A_m$  = Air mass (g)

$V_a$  = Air volume (cc)

$\rho$  = Air density (g/cc)

In an automotive FI application the quantity of fuel to be injected can be calculated if the displacement volume of the cylinder and the density of air within the cylinder at the onset of the compression stroke are known.

The air density could be determined by measuring the absolute pressure and absolute temperature of the air. In an automotive application it is, however, not practical to directly measure the air pressure and temperature inside the cylinder. To overcome this limitation the air pressure and temperature are measured in the inlet manifold. This leads to certain pressure measurement errors for which corrections have to be made.

To understand and correct these errors the engine is modelled as an air pump. For the purpose of explaining these problems one has to view the engine as a pump sucking air from the inlet manifold through a restriction which is formed by the inlet valve in the open position. The dynamic properties of the air moving past the inlet valves are engine speed dependent and to such an extent that the inlet manifold pressure will tend to be slightly higher than the in-cylinder pressure at the end of an inlet stroke. This leads to higher than actual air mass measurements which have to be corrected. The air pumping efficiency is called the volumetric efficiency of the engine.

**Volumetric efficiency depends mainly on the:**

- a) Inlet valve and camshaft design**
- b) Inlet manifold design**
- c) Engine speed**

**The volumetric efficiency is normally less than one (1) and has the effect that the actual air mass entering the cylinder will be less than the measured value.**

**Peak volumetric efficiency co-incides with the engine speed where the maximum torque is developed.**

## **7.4 FUEL METERING**

**Now that a method has been established to determine the air mass entering the engine it is possible to calculate the quantity of fuel to be injected to achieve the required A/F ratio. An electric fuel pump delivers fuel at a constant pressure to the injector which is opened for the required injection duration. The fuel pressure is regulated by a mechanical pressure regulator.**

**The fuel mass to be injected is:**

**$F_m = A_m / (A/F)$  Where  $F_m$  = Fuel mass  
 $A_m$  = Air mass**

**Since the fuel is injected in bursts it is necessary to know the fuel flow rate of the injector, pump and regulator system, as well as the injector opening and closing delays at various battery voltages to enable calculation of the injection duration.**

## 7.5 CONTINUOUS FUEL FLOW RATE

The continuous fuel flow rate at a constant battery voltage is dependent on the injector design, fuel pump and fuel pressure used. Tests have shown that the fuel flow rate, for the Rochester TBI system, is dependent on the applied battery voltage.

The fuel flow rate becomes lower with reduced battery voltage. The ECU compensates for this effect by lengthening the injection pulses at low battery voltages.

## 7.6 INJECTOR OPENING AND CLOSING TIME

The current, through the injector coil, creates a magnetic field which moves the armature, thus opening the nozzle allowing fuel to be injected. Short opening times therefore require a fast build up of current in the injector. This requires a low inductance or a high applied voltage. Short closing times require a low holding current which is obtained by reducing the opening current while the injector is open to a current just large enough to keep the injector open. Since the available voltage in automotive applications is restricted to the battery voltage (6 to 13.8V) the injectors are normally designed to have low inductance.

The measured characteristics of the test injector are:

Inductance = 4mH  
Resistance = 1.5 ohm  
Static opening current = 1.1A \*  
Static closing current = 0.5A \*

\* Static opening and closing current is independent of fuel pressure.

**The injector drive circuit allows a pull-in current of 4A and a holding current of 1A. Once an injector current of 4A is reached the circuit will automatically reduce it to 1A.**

**Injector opening and closing times vary with battery voltage and vary between 0.2 ms at 14 volt and 1.35 ms at 6.5 volt. The ECU takes this into account by measuring the battery voltage before calculating the injection times.**

**The electrical opening duration of the injector consists of the sum of the opening and closing delays and the true required injection duration.**

## **7.7 INJECTION TIMING**

**Under static conditions (constant engine load and speed) fuel will be injected in synchronisation with the crankshaft position and speed reference signal, i.e. once per intake stroke. Fuel injection will commence 0.5 ms after the 10° BTDC reference.**

## 7.8 INJECTION DURATION

The base injection duration for different loads and engine speeds is calculated and fine tuned by mapping to ensure that the required A/F ratio is obtained under static operating conditions. ( $\Lambda = 1$ ) **Injection durations vary from 1 to 5 milliseconds.**

The following operating parameters were assumed for the purpose of obtaining the base map:

- a) Continuous fuel flow rates with battery voltage at 14 volt.
- b) Intake air temperature at 303.7  $\text{K}$ .
- c) Zero injector delay.
- d) One injection cycle per intake stroke.

## 7.9 CORRECTION FACTORS

Correction factors are applied to the base map to correct for injection hardware deficiencies and engine operating conditions.

### 7.9.1 Injection hardware deficiencies.

The reduced fuel flow rate at low battery voltages necessitates an increase in the injection duration. The factor by which the injection durations from the base map has to be multiplied is obtained by normalising the fuel flow rate at different battery voltages with respect to 14.0 volt.

In addition to the above multiplication factor the base map injection times are further increased by the injector delays to ensure that the correct quantity of fuel is injected.



### **7.9.2 Engine operating conditions.**

The following engine operating conditions require additional modifications to the base injection map.

### **7.9.3 Intake air temperature.**

The oxygen content of the intake air is proportional to the air density and inversely proportional to the air temperature. It is therefore necessary to correct the base map for intake air temperature variations. An air intake temperature correction factor which is normalised with respect to 303.70K is therefore used.

### **7.9.4 Engine temperature.**

Cold engines exhibit more friction and therefore require slightly richer A/F ratios to ensure smooth running. Corrections are made for engine temperatures from -130C to 1100C and normalised with respect to 1000C.

Cold intake manifolds result in considerable wall-wetting which means that all the injected fuel does not atomise to form a combustionable mixture. Additional fuel has to be injected to overcome this effect.

### **7.9.5 Cold starting conditions.**

**Definition: Engine speed < 450 r.p.m.**

**During cold start conditions the low inlet manifold temperatures cause considerable fuel condensation on the inner walls of the manifold. This condition is known as wall wetting. To ensure correct A/F ratios it is necessary to increase the quantity of fuel injected during cold starting conditions to counteract wall wetting. A correction factor is applied to the base map for engine temperatures between -40°C and 100°C.**

**To prevent the engine from flooding the enrichment factor is not only engine temperature dependent, but also time dependent. This is implemented by reducing the enrichment factor over a number of crankshaft revolutions, regardless of engine temperature. If the ignition is turned off and an attempt is made to re-start the engine the process is repeated.**

### **7.9.6 Post start and warm-up conditions.**

**Definition: Engine speed > 450 r.p.m.  
Engine temperature < 80°C**

**During these conditions the engine temperature is monitored and the A/F ratio is decreased by lengthening the base map injection duration to ensure smooth running of the engine and to compensate for inlet manifold wall-wetting.**

### **7.9.7 Acceleration conditions.**

**During a sudden increase in throttle opening at constant engine speed the air mass entering the manifold and combustion chamber increases almost immediately due to the low density of air, whilst the higher density fuel lags behind. This leads to lean mixtures for a short duration if no compensation is applied. This effect manifests itself as a hesitation, at the onset of vehicle acceleration.**

**To compensate for this effect a pre-determined rate of throttle opening is detected and the effective injection duration is increased. This enrichment will be gradually decreased over a number of crankshaft revolutions.**

### **7.9.8 Deceleration lean-out conditions**

**While driving with the throttle in the part load region a slight reduction in power demand (throttle opening being reduced) will result in a momentary enrichment of the A/F ratio. The ECU prevents this decrease in A/F by making the injection time shorter for a limited period when detecting the above conditions.**

### **7.9.9 Coasting conditions.**

**When the throttle is closed and the engine speed is above the coasting cut-out speed the ECU will shut the fuel supply off to save fuel. The engine speed at which fuel is cut off is temperature dependent to prevent engine stalling under cold conditions.**

### **7.9.10 Flooded engine conditions.**

**When the engine speed is below 450 r.p.m. and WOT is detected the ECU will reduce the base map injection durations by 40% and ignore all cold and post-start corrections in an attempt to prevent further flooding.**

### **7.9.11 Full load operation**

**Under full load operation the engine is required to deliver maximum power and requires a richer A/F ratio. This condition is detected when the engine speed is above 450 r.p.m. and WOT is selected allowing the ECU to increase the base map injection duration by a given factor to ensure maximum power delivery.**

## **8 IDLE SPEED CONTROL**

**Idle speed is controlled by means of the IACV (Idle Air Control Valve) mounted on the throttle body assembly. The IACV is driven by the IACSM (Idle Air Control Stepper Motor) which is controlled by the ECU.**

**The IACV maintains constant idle speed (temperature dependent) under all engine loads.**

**The ECU makes use of closed loop control algorithms to ensure the best idle conditions for warm and cold engines. Whenever the ignition is first switched the ECU selects a pre-set idle position which is temperature dependent, thereafter it operates in the closed loop control mode.**

**Idle speed control is only possible with the throttle in the closed position.**

**Timing advance support is utilised in the idle range to enhance idle speed control. Spark timing is advanced by up to 10° if the idle speed drops below the set point, resulting in increased engine torque to offset the drop in speed. If the idle speed rises above the set point the timing will be retarded up to 10° to reduce engine torque.**

**Correct idle speed control is not possible when the battery voltage is below 9 volt.**

## **9 IMMOBILISER OPERATION**

The system contains an immobiliser function which prevents hot-wiring. When the ignition is switched on the ECU will wake up and prompt the ACU for its ID (Identification Code). The ACU will respond by sending its ID to the ECU for comparison with an ID code stored in the ECU's ROM. Only if the ACU's ID matches the ECU's ID normal engine management control will be allowed to take place.

**NO ENGINE CONTROL IS POSSIBLE IN THE ABSENCE OF THE CORRECT ACU ID.**

## 10 DEFAULT MODE SELECTION

When the ECU detects a faulty signal from one of its sensors it will substitute a default signal value to enable the vehicle to be driven with degraded performance (see paragraph 10.1).

| <b>Faulty sensor</b>   | <b>Substitute value/sensor</b> |
|--|--------------------------------|
| <b>EWT</b>   | <b>Warm engine - 100 °C</b>    |
| <b>MAT</b>   | <b>31 °C</b>                   |
| <b>Fuel map selector</b>   | <b>Zero percent enrichment</b> |
| <b>Timing map selector</b>   | <b>Map T1 - RON 87D</b>        |
| <b>TPS</b><br><b>2,000 r.p.m.</b>  | <b>Idle speed - 1,000 to</b>   |
| <b>MAP</b><br><b>1,000 to 2,000 r.p.m.</b>   | <b>TPS and idle speed -</b>    |
| <b>Disable distributor</b><br><b>bypass operation and</b><br><b>fix spark timing at</b><br><b>10° BTDC</b> |                                |
| <b>CO potentiometer</b>  | <b>Zero percent</b>            |

## **11 DIAGNOSTICS**

Various possible methods of fault finding are listed below to reduce down-time of the vehicle.

### **11.1 Diagnostic codes**

The CPU continuously monitors its own activities and sensor inputs. If a fault is detected during operation the diagnostic lamp is turned on and a default signal value is used to allow the car to be driven with slightly reduced performance. The fault code is stored in RAM for later evaluation by the Dealer. If the fault disappears the unit will immediately use the sensor data instead of the default data, thus ensuring optimum performance. The fault will be erased from RAM after 7 starts (ignition turned on 7 times) during which no fault was detected.

The fault stored in RAM could be accessed by grounding the diagnostic initialisation input terminal. The fault will then be flashed out by the diagnostic lamp.



## DIAGNOSTIC CODES

| <b>Code</b> | <b>Cause</b>  |
|-------------|---|
| 14          | Coolant temperature sensor voltage too low                                |
| 15          | Coolant temperature sensor voltage too high                               |
| 21          | TPS voltage too high  |
| 22          | TPS voltage too low   |
| 25          | MAT sensor voltage too low  |
| 26          | MAT sensor voltage too high   |
| 33          | MAP sensor voltage too high   |
| 34          | MAP sensor voltage too low  |
| 35          | Idle control stepper motor failure  |
| 36          | Timing map selector error   |
| 42          | Reference signal error/Engine stall<br>(Diagnostic lamp will not turn ON) |
| 44          | Fuel map selector error   |
| 48          | Battery voltage too low   |
| 49          | Battery voltage too high  |
| 65          | CO potentiometer voltage out of range                                     |



**11.2.5 CO potentiometer supply voltage:** The voltage between terminal 23B and signal ground should be between 4.7 and 5.2 volt.

**11.2.6 MAP sensor supply voltage:** The voltage between terminal 24B and signal ground should be between 4.7 and 5.2 volt.

**11.2.7 MAP sensor signal voltage:** The voltage between terminal 15B and signal ground with ignition on should be:

| <b>MAP signal voltage</b> | <b>Manifold absolute pressure</b> |
|---------------------------|-----------------------------------|
|---------------------------|-----------------------------------|

---

|             |                |
|-------------|----------------|
| <b>1.00</b> | <b>20 kPa</b>  |
| <b>2.00</b> | <b>40 kPa</b>  |
| <b>3.00</b> | <b>60 kPa</b>  |
| <b>4.00</b> | <b>80 kPa</b>  |
| <b>4.50</b> | <b>90 kPa</b>  |
| <b>5.00</b> | <b>100 kPa</b> |

**A general tolerance of +/- 5% exists on the above voltages.**

**11.2.8 Timing map selector: The resistance between terminal 19B and 22B measured on the harness connector with the ECU removed should be:**

**97 RON - 470 ohm**

**93 RON - 220 ohm**

**87 RON - 4,700 ohm**

**87D RON - 5,600 ohm**

**11.2.9 Fuel mixture selector: The resistance between terminal 18B and 11A measured on the harness connector with the ECU removed should be:**

**-15% - 274 ohm**

**-10% - 340 ohm**

**-05% - 412 ohm**

**+05% - 619 ohm**

**+10% - 768 ohm**

**+15% - 931 ohm**

**+20% - 1180 ohm**

**+25% - 1500 ohm**

**11.2.10 EWT sensor: The resistance between terminal 16B and 11A on the harness connector with the ECU removed should be:**

| <b>EWT °C</b> | <b>Resistance (ohm)</b> |
|---------------|-------------------------|
| <b>-20</b>    | <b>19,700</b>           |
| <b>-0</b>     | <b>5,640</b>            |
| <b>+20</b>    | <b>2,410</b>            |
| <b>40</b>     | <b>1,177</b>            |
| <b>60</b>     | <b>565</b>              |
| <b>80</b>     | <b>308</b>              |
| <b>100</b>    | <b>186</b>              |

**11.2.11 MAT sensor: The resistance between terminal 17B and 11A on the harness with the ECU removed should be:**

| <b>MAT °C</b> | <b>Resistance (ohm)</b> |
|---------------|-------------------------|
| <b>-12</b>    | <b>9,977</b>            |
| <b>-5</b>     | <b>6,540</b>            |
| <b>0</b>      | <b>5,627</b>            |
| <b>18</b>     | <b>2,290</b>            |
| <b>33</b>     | <b>1,241</b>            |
| <b>48</b>     | <b>782</b>              |
| <b>62</b>     | <b>485</b>              |