

Clawbot Build Instructions



276-6009-750

Parts List

All V5 Control System, gears, wheels, wires, and structure are not to scale
All other parts listed are 1:1 scale.
Hacksaw is required, ask a parent/mentor for help.

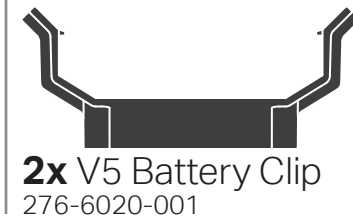
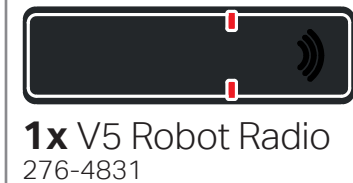
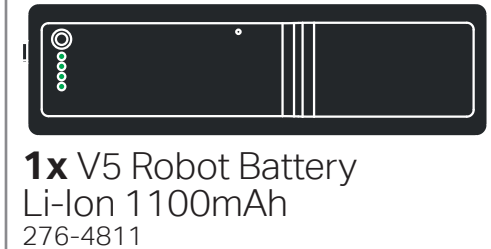
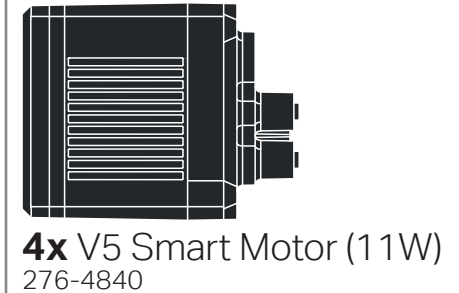
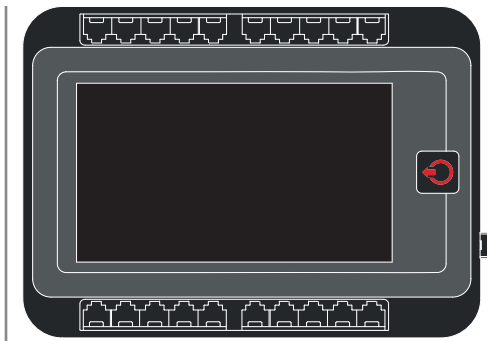
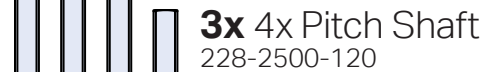
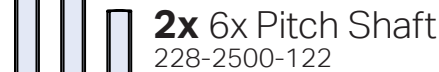
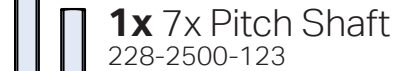
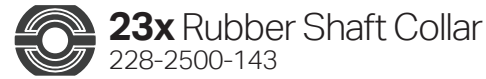
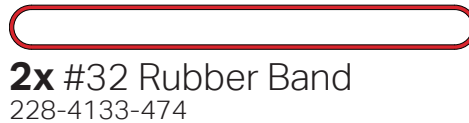
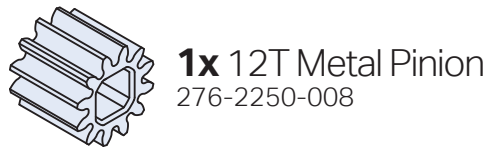
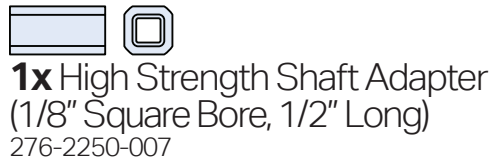
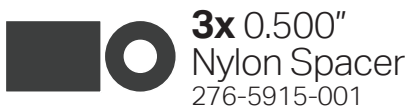
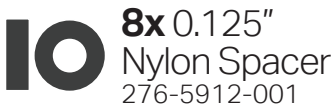
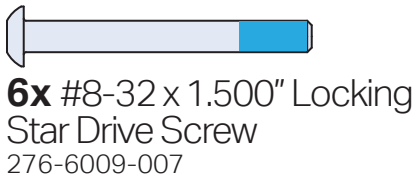
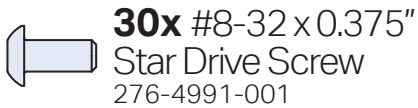

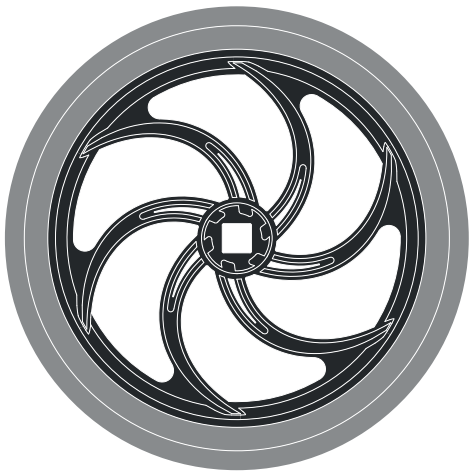

2x 4" Wheel
276-6299-000

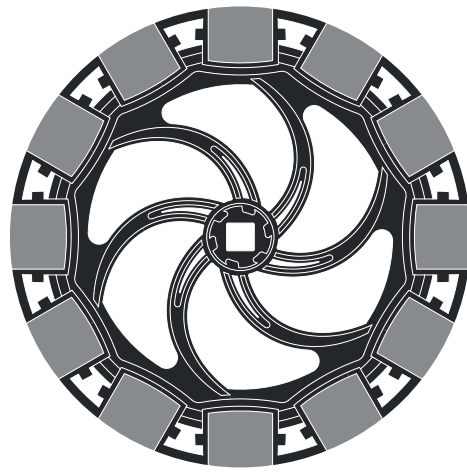

2x 4" Omni-Directional Wheel
276-6298-000



1x 180 mm V5 Power Cable 276-4817-100

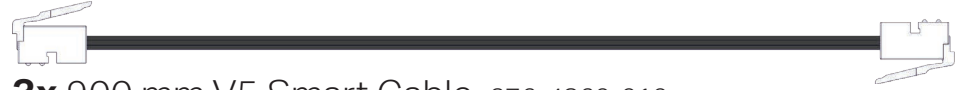

3x 900 mm V5 Smart Cable 276-4860-010



1x 600 mm V5 Smart Cable 276-4860-030



1x 300 mm V5 Smart Cable 276-4861-020

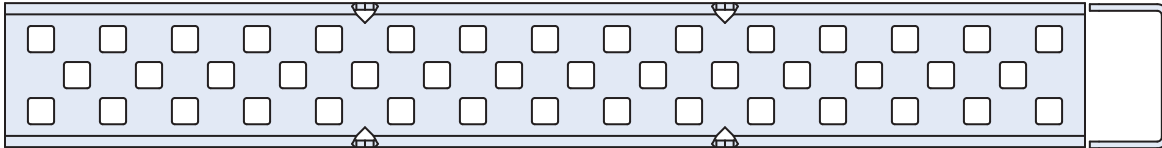

2x C-Channel 1x2x1x15 276-2232-028

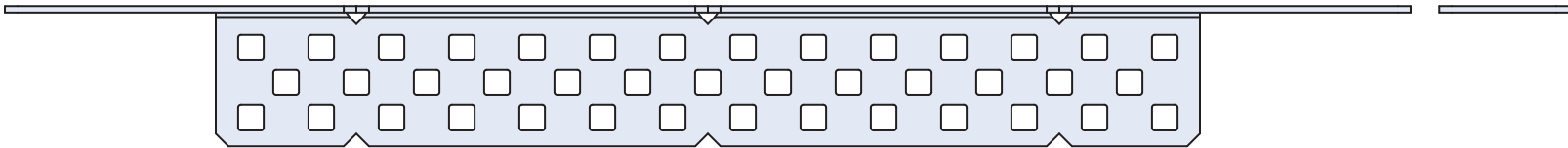

2x Angle 2x2x14x20 276-6009-002

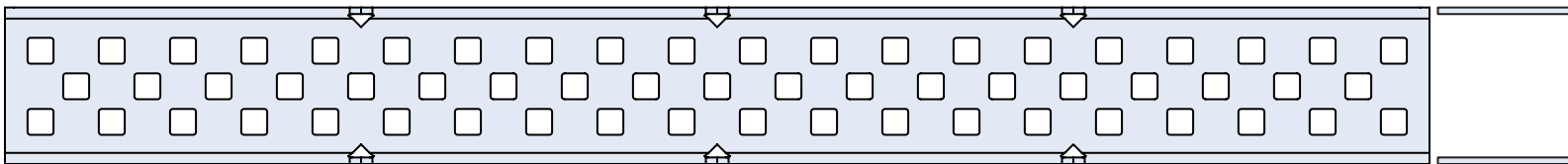

3x U-Channel 2x2x2x20 276-6009-001

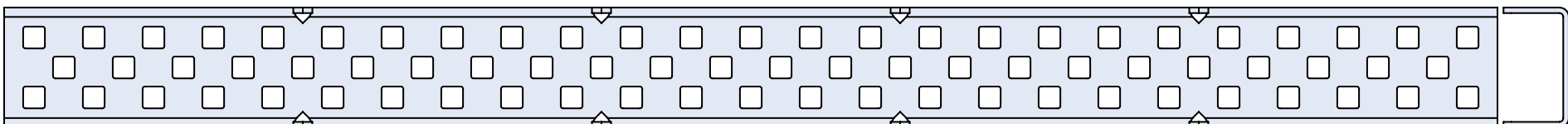

2x C-Channel 1x2x1x25 276-2232-029

For build instructions using the
Cortex System Bundle, please visit:
www.vexrobotics.com/v5/downloads/build-instructions

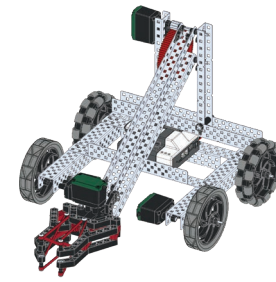

2x #8-32 x 0.375"
Star Drive Screw
276-4991-001



2x 4-Post Hex Nut Retainer
276-6009-005



2x #8-32 Hex Nut
275-1028-001

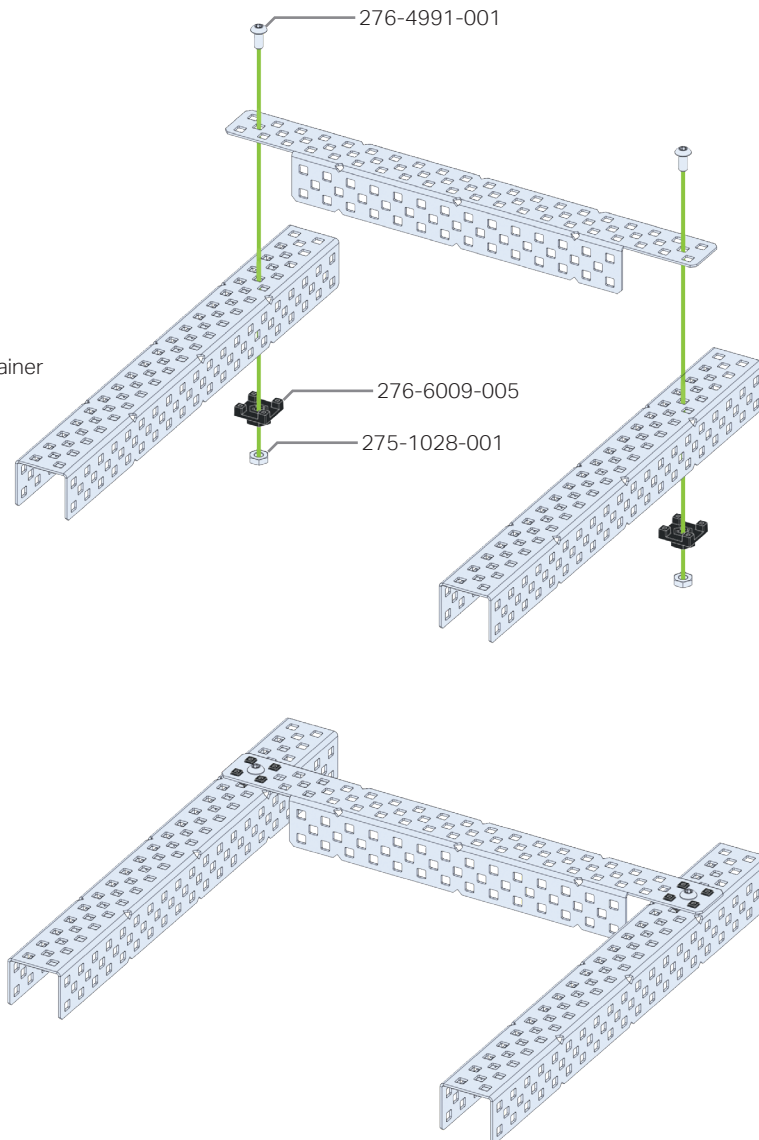

2x #8-32 x 0.375"
Star Drive Screw
276-4991-001



2x 4-Post Hex Nut Retainer
276-6009-005



2x #8-32 Hex Nut
275-1028-001

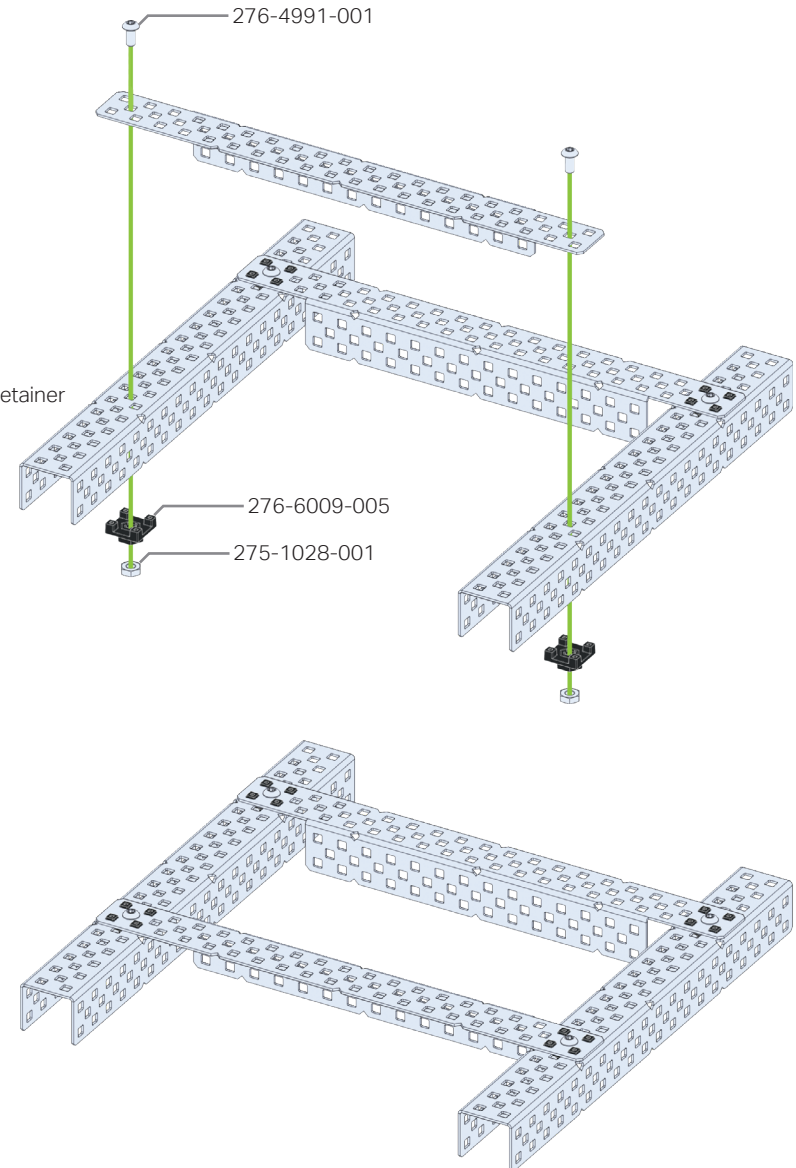

3



2x #8-32 x 0.375"
Star Drive Screw
276-4991-001



2x 4-Post Hex
Nut Retainer
276-6009-005



2x #8-32
Hex Nut
275-1028-001

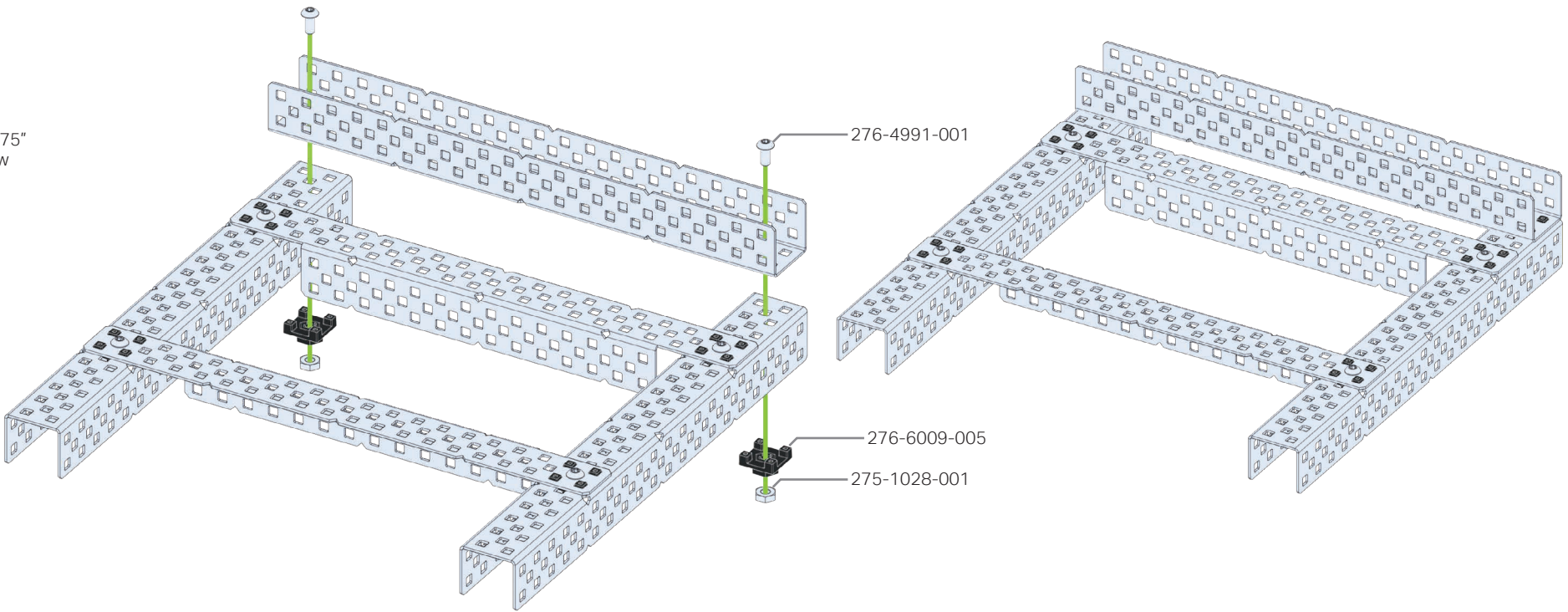

4



2x 1-Post Hex Nut
Retainer w/ Bearing Flat
276-6009-003



2x #8-32 x 0.375"
Star Drive Screw
276-4991-001



2x #8-32
Hex Nut
275-1028-001

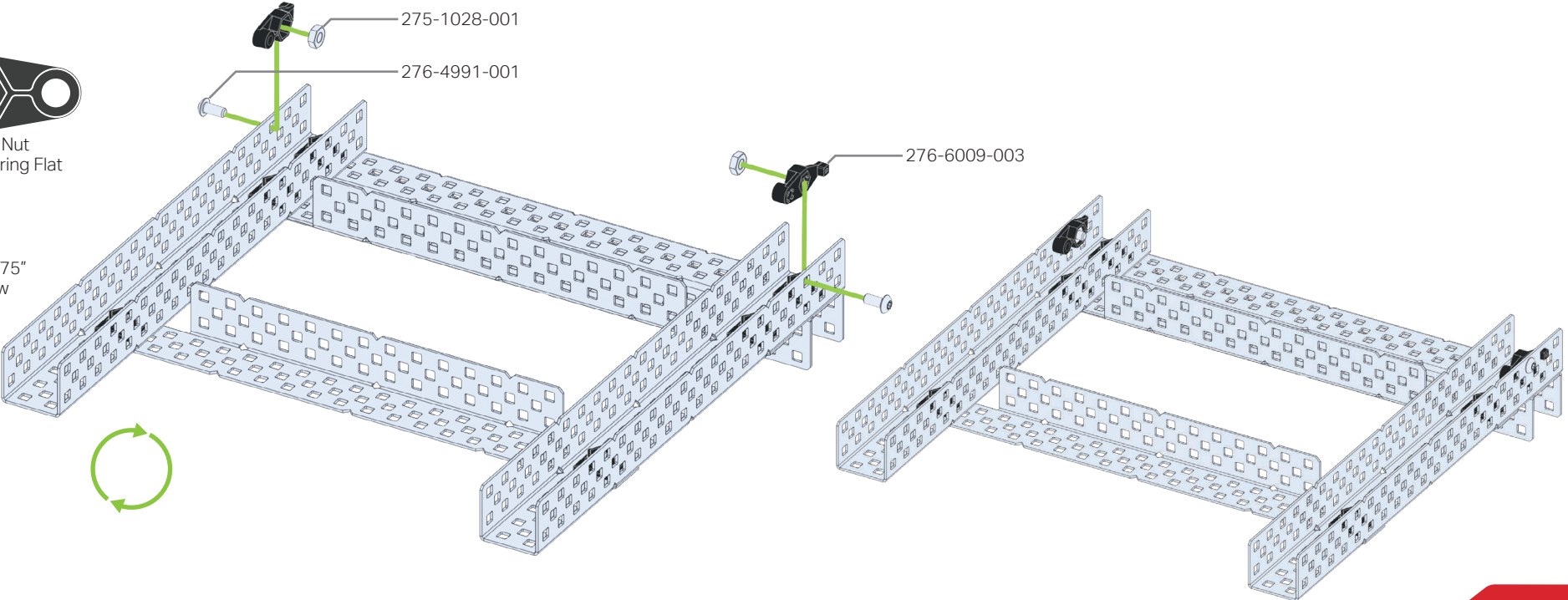

5



2x 1-Post Hex Nut Retainer w/ Bearing Flat
276-6009-003



2x #8-32 x 0.375" Star Drive Screw
276-4991-001



2x #8-32 Hex Nut
275-1028-001

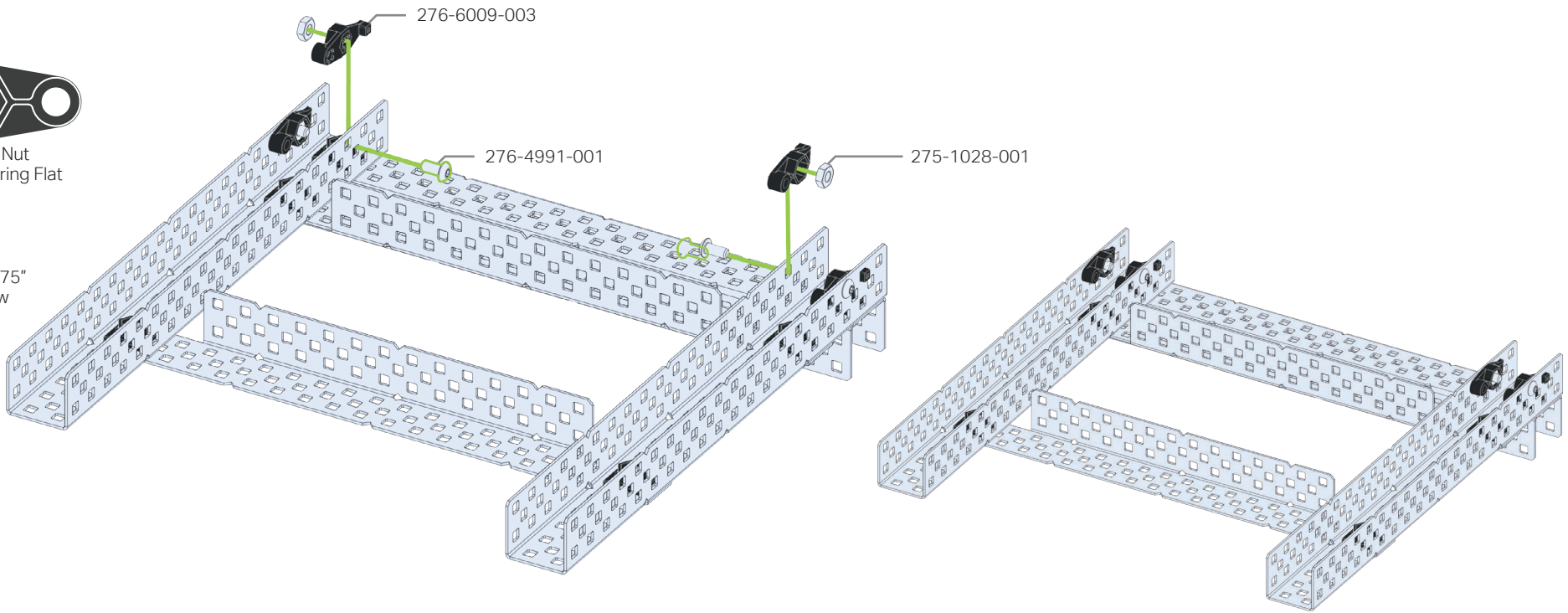

6

2X 228-2500-143

228-2500-124

276-1209-001



1x Rubber Shaft Collar
228-2500-143



2x Bearing Flat
276-1209-001

1x 8x Pitch Shaft
228-2500-124

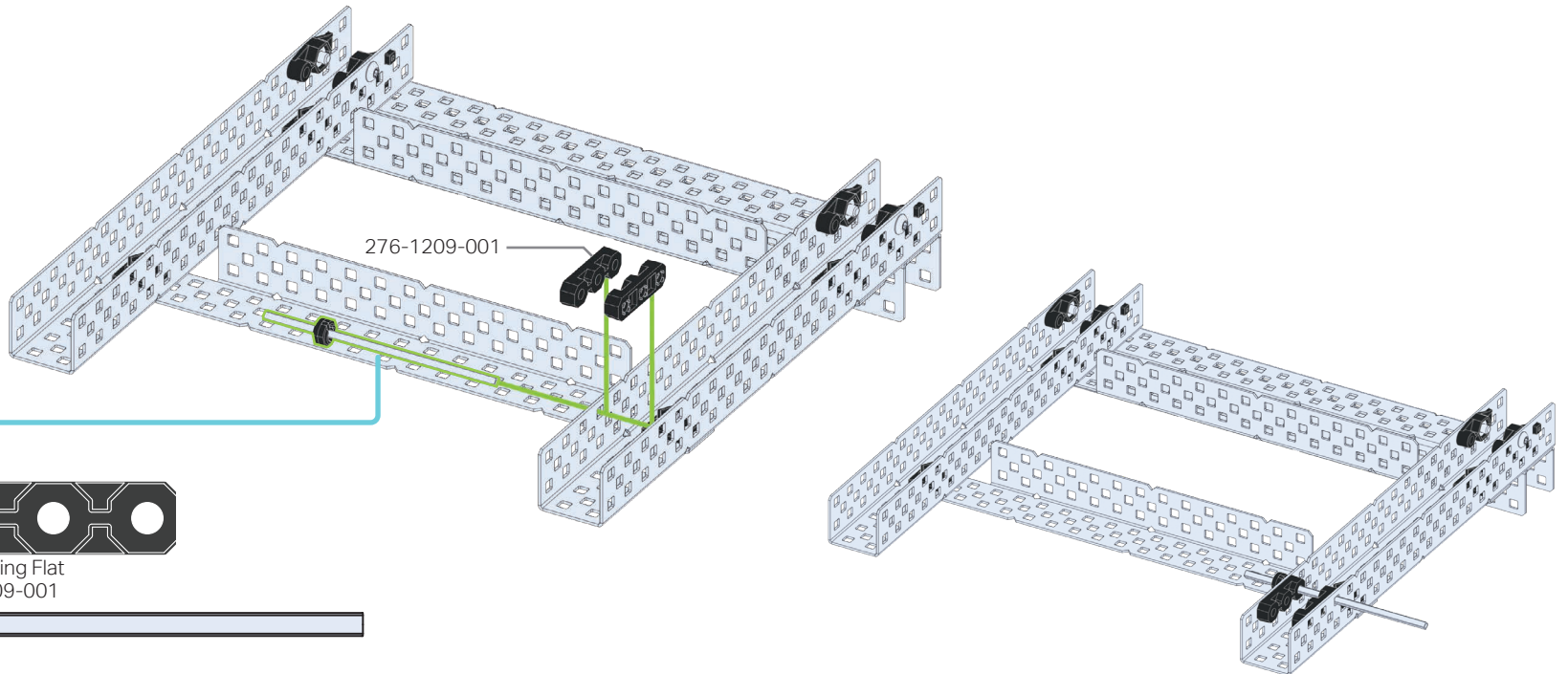

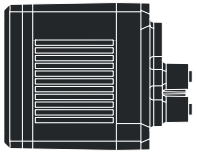

1x V5 Smart Motor (11W)
276-4840-000

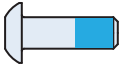

1x #8-32 x 0.500"
Locking Star
Drive Screw
276-5007-001

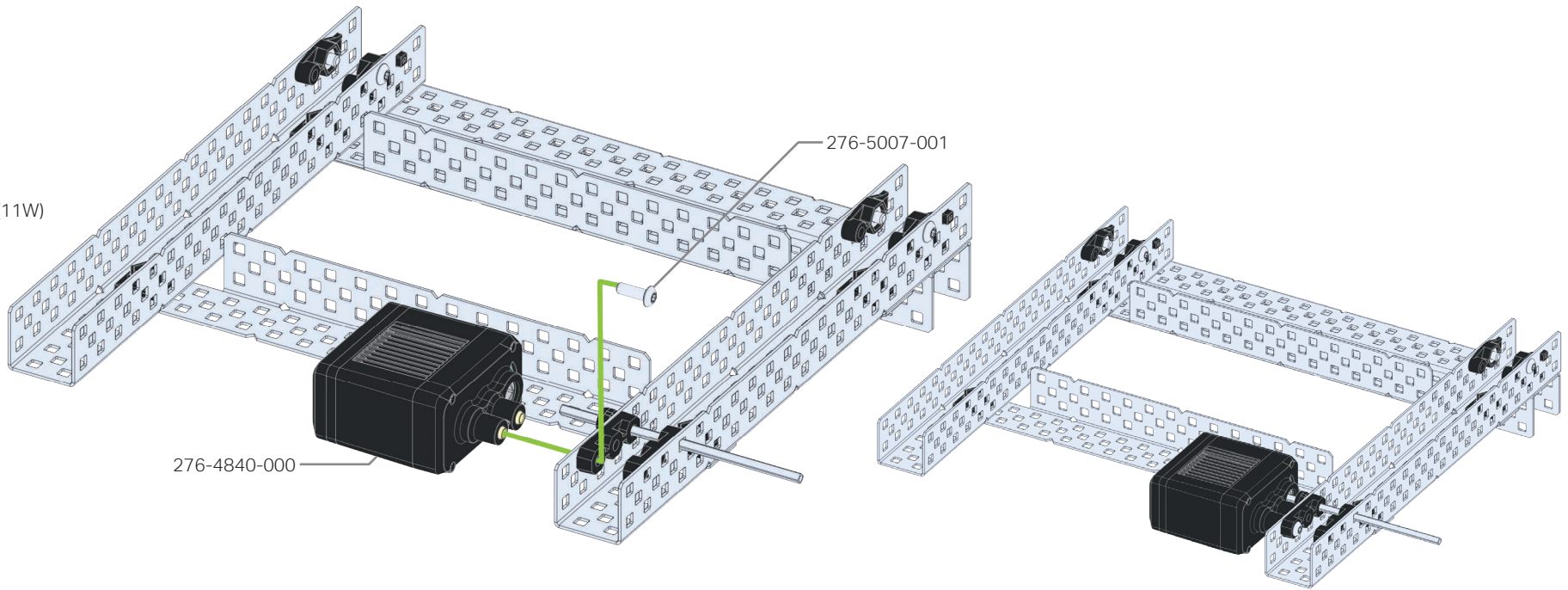

1x 0.500" Nylon Spacer
276-5915-001



1x #8-32 x 1.500"
Locking Star Drive Screw
276-6009-007

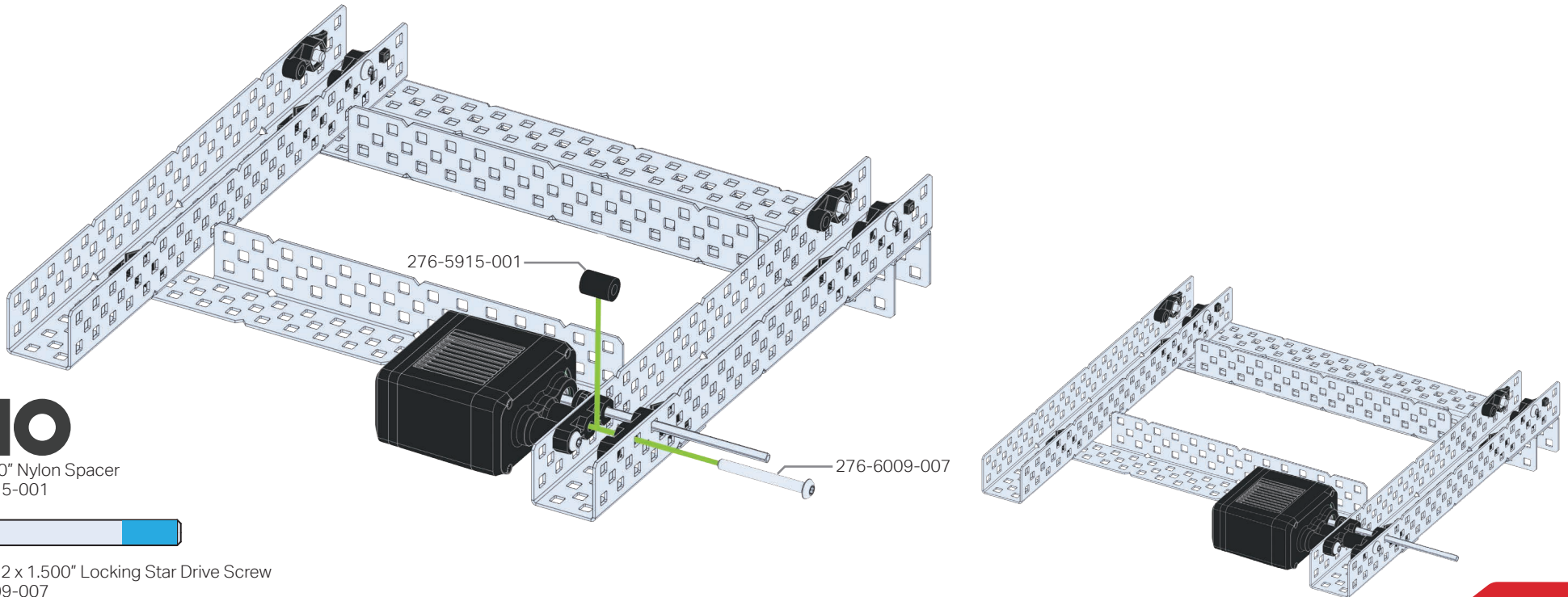



276-1209-001

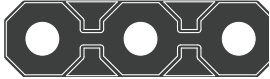
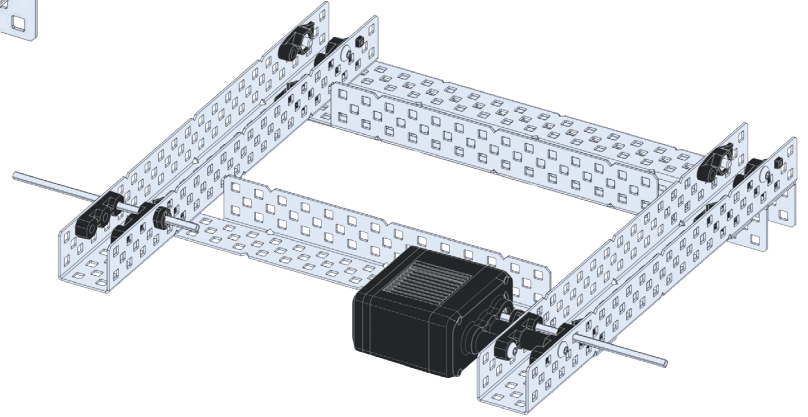
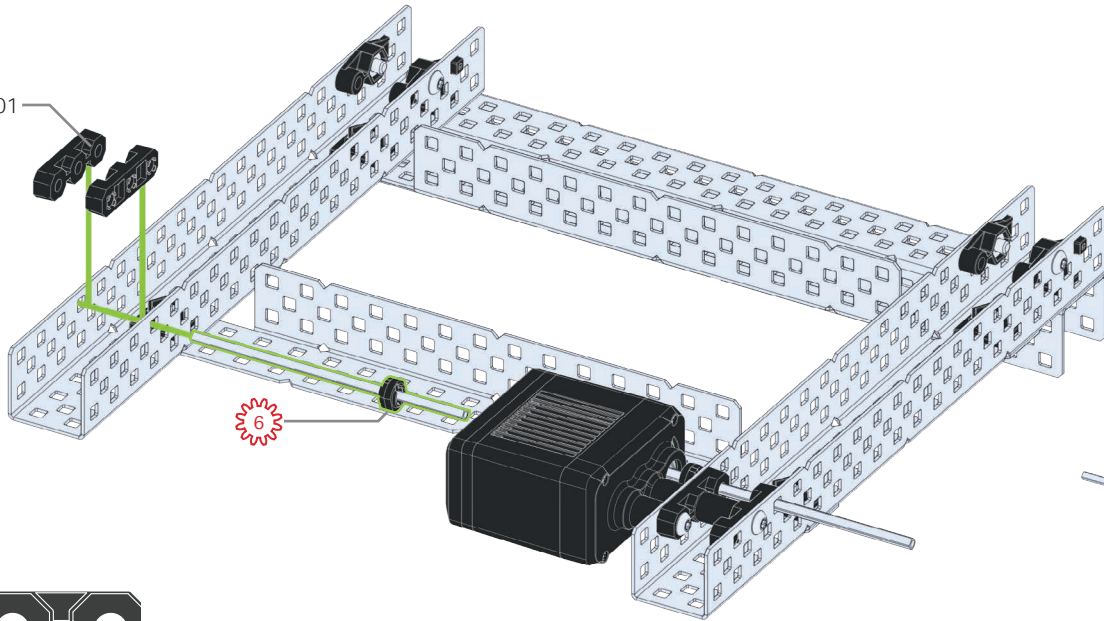

2x Bearing Flat
276-1209-001



276-5007-001

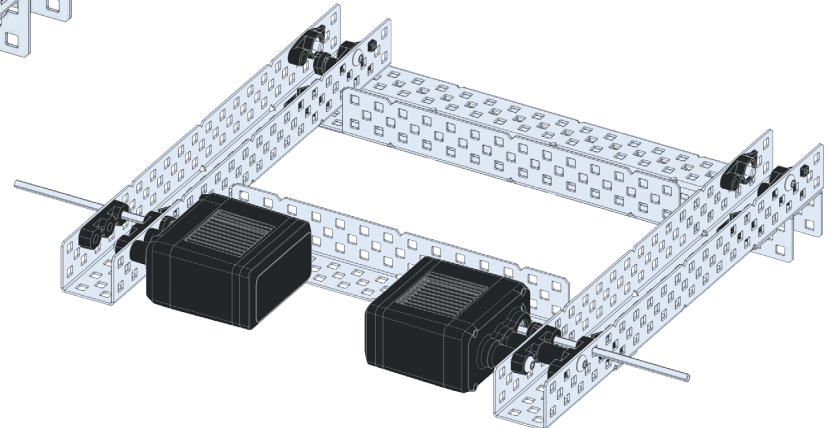
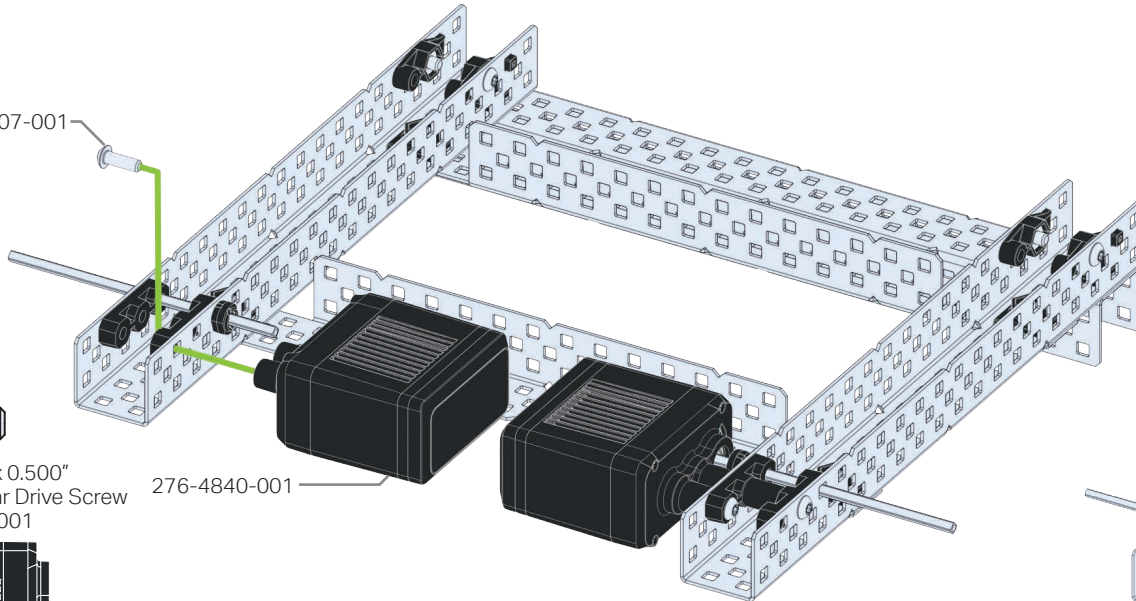

1x #8-32 x 0.500"
Locking Star Drive Screw
276-5007-001

276-4840-001

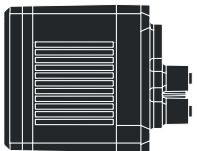

1x V5 Smart Motor (11W)
276-4840-001

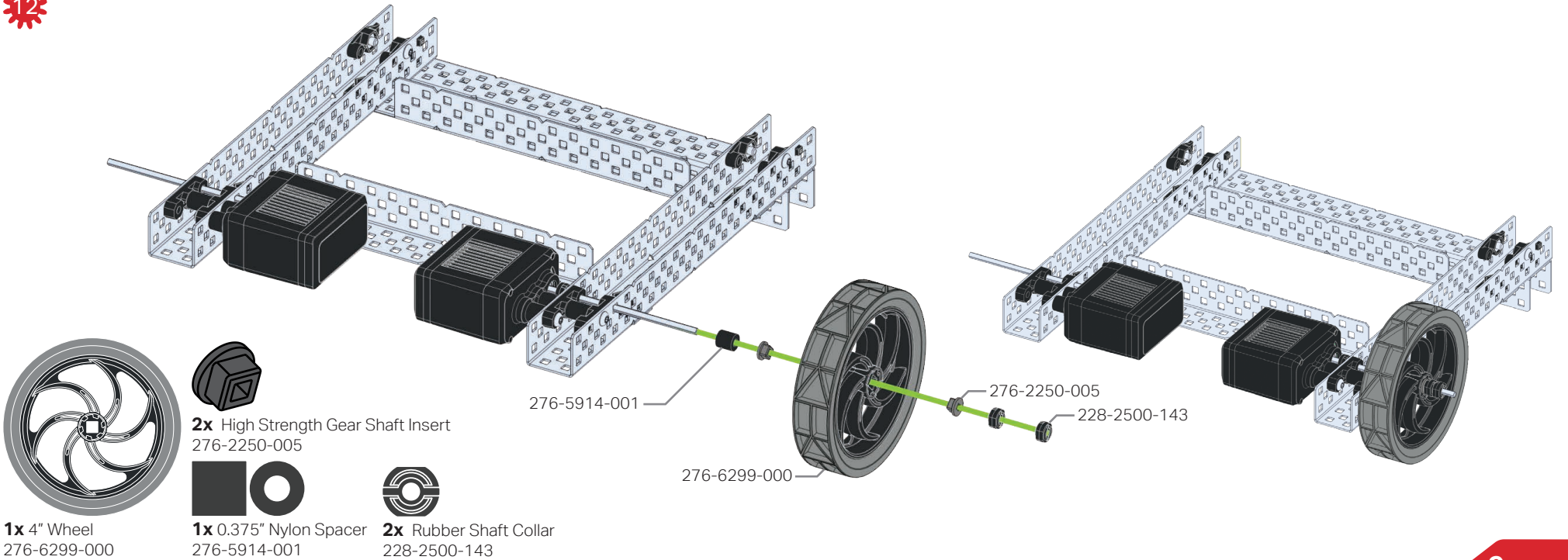
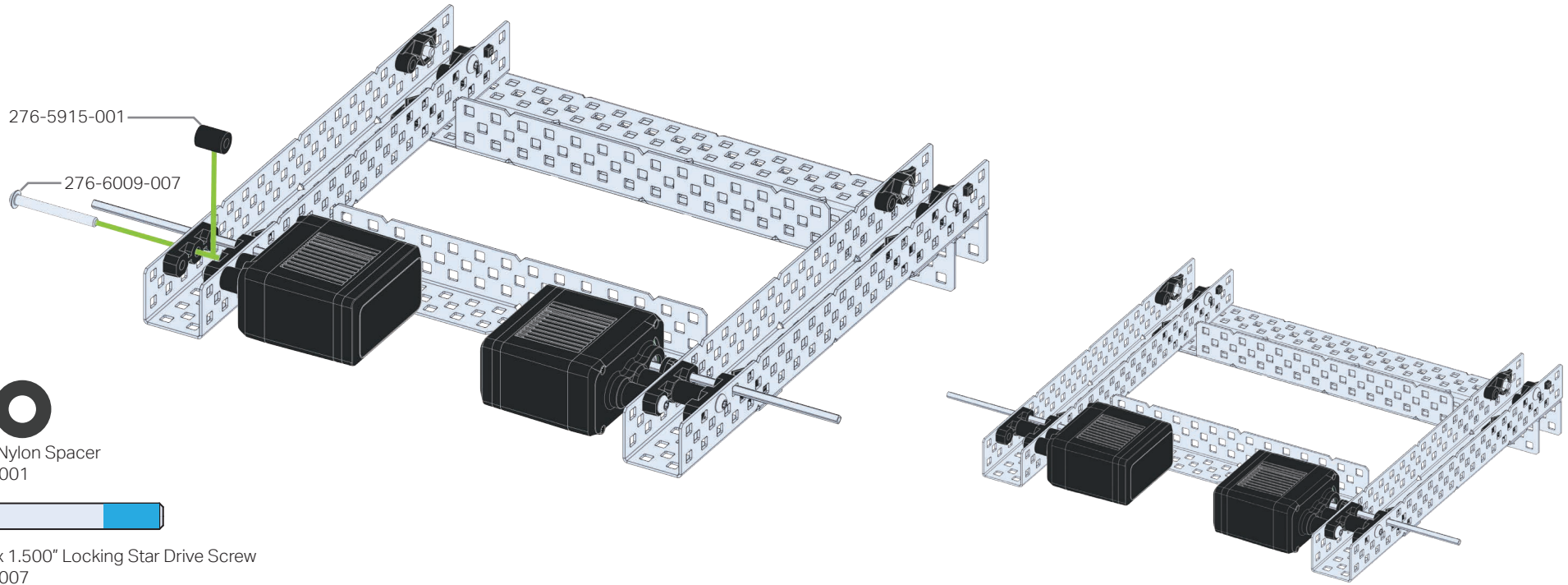

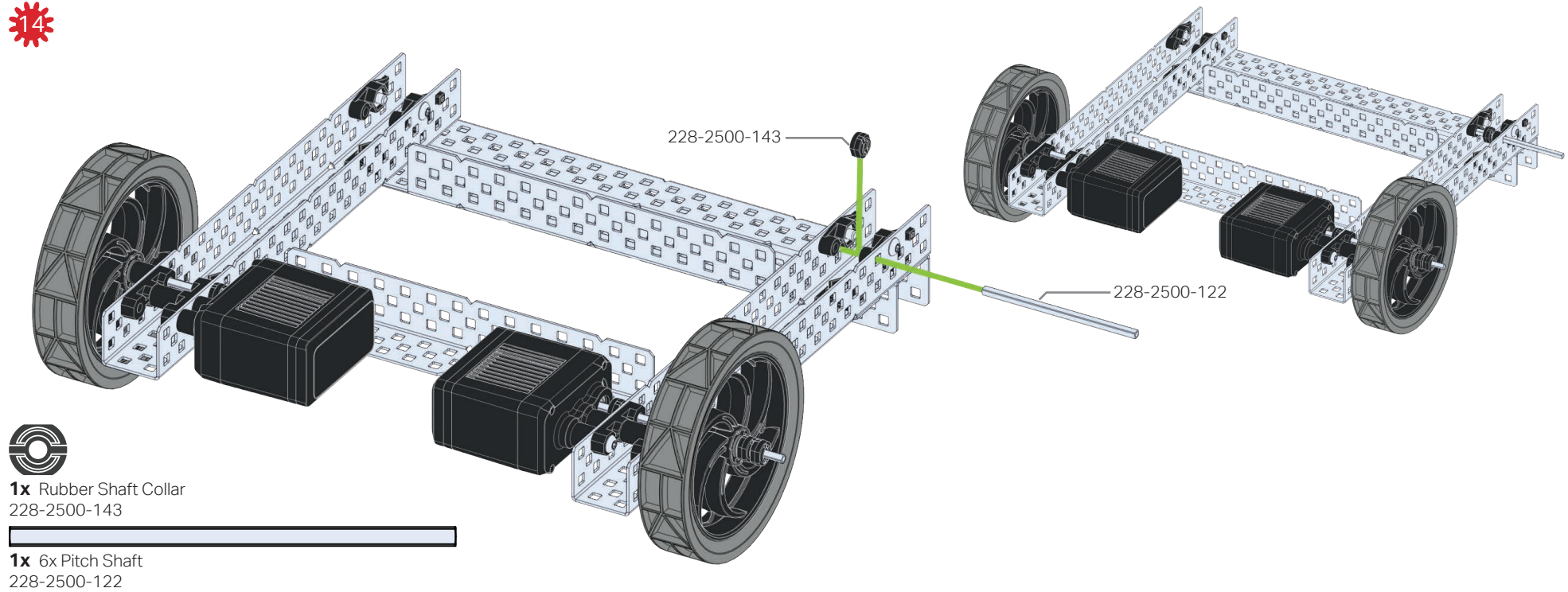
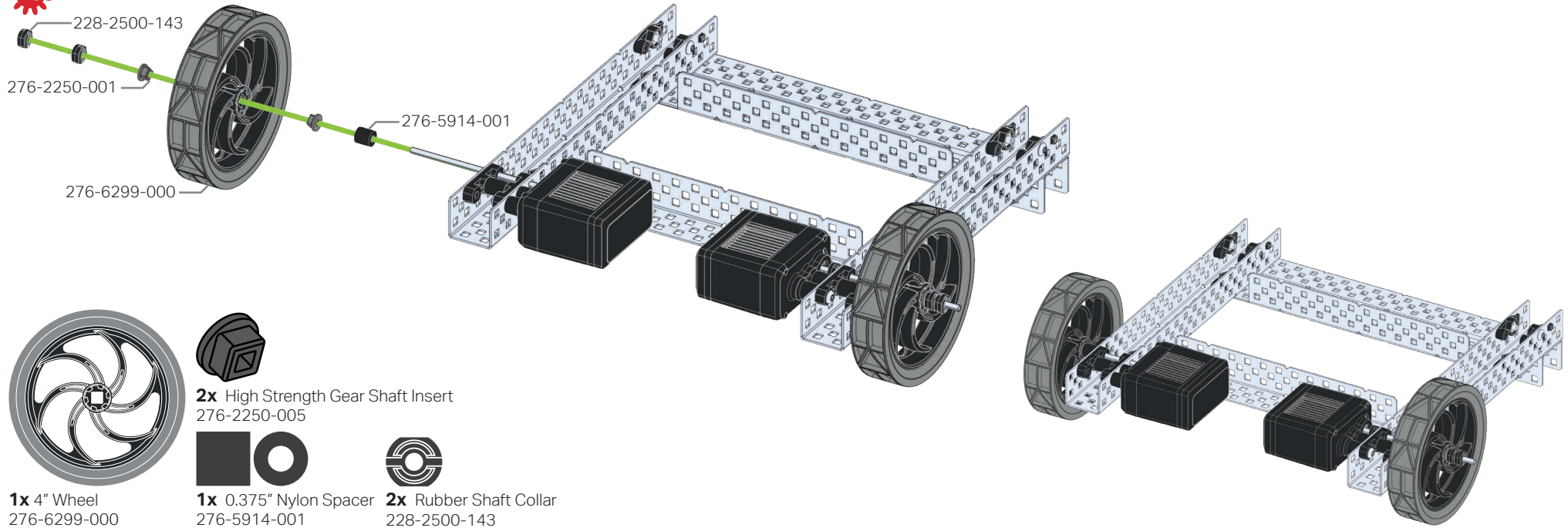

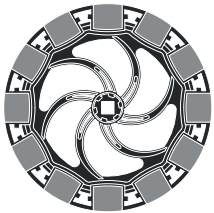

1x 4" Omni-Directional Wheel
276-6298-000



2x Rubber Shaft Collar
228-2500-143



1x 0.375" Nylon Spacer
276-5914-001



2x High Strength Gear Shaft Insert
276-2250-005

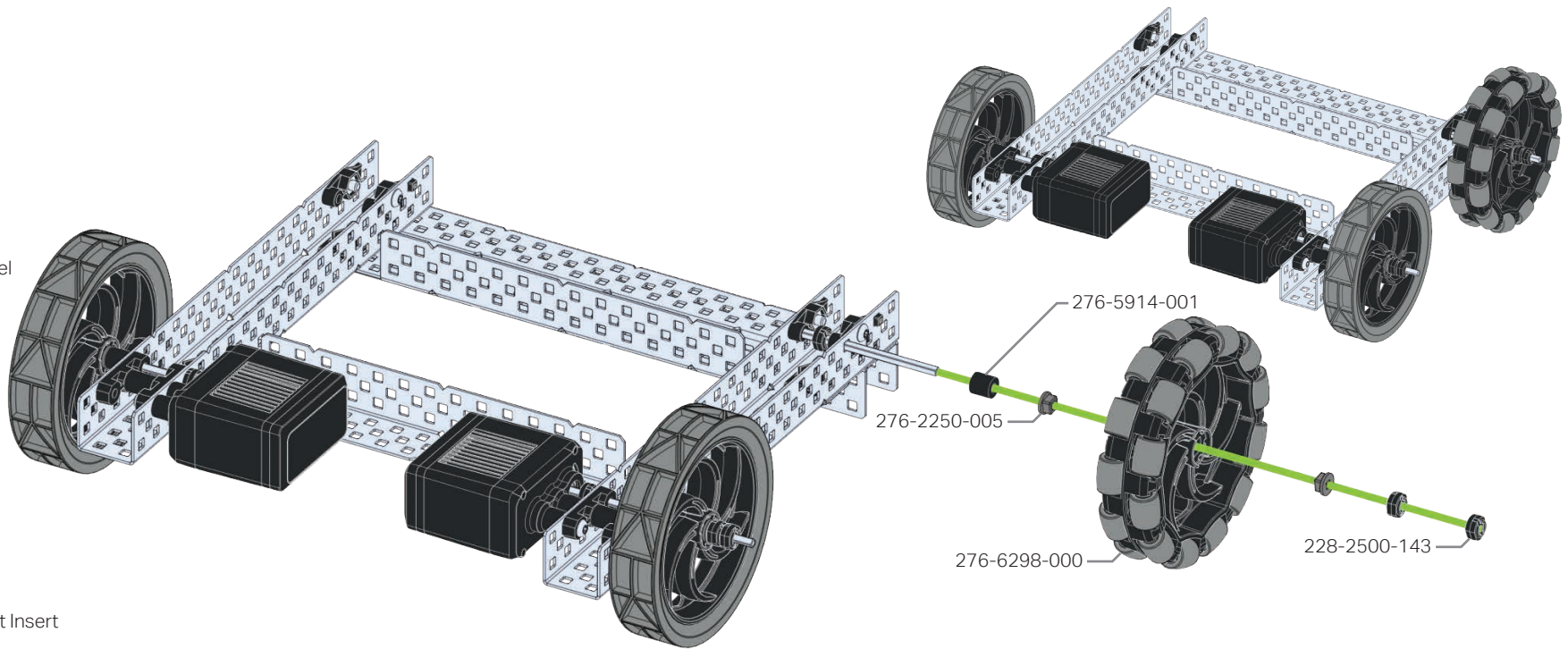

228-2500-143

228-2500-122



1x Rubber Shaft Collar
228-2500-143

1x 6x Pitch Shaft
228-2500-122

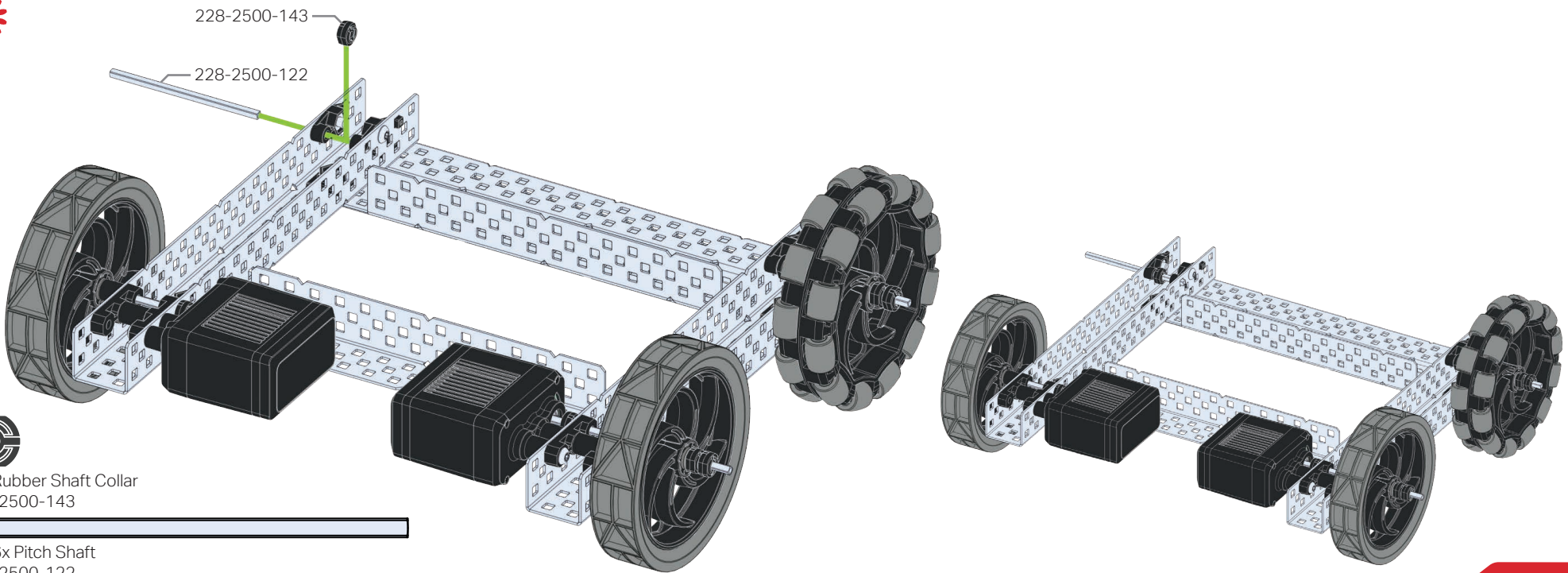



2x Rubber Shaft Collar
228-2500-143



1x 0.375" Nylon Spacer
276-5914-001



2x High Strength Gear Shaft Insert
276-2250-005

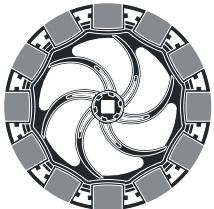

1x 4" Omni-Directional Wheel
276-6298-000

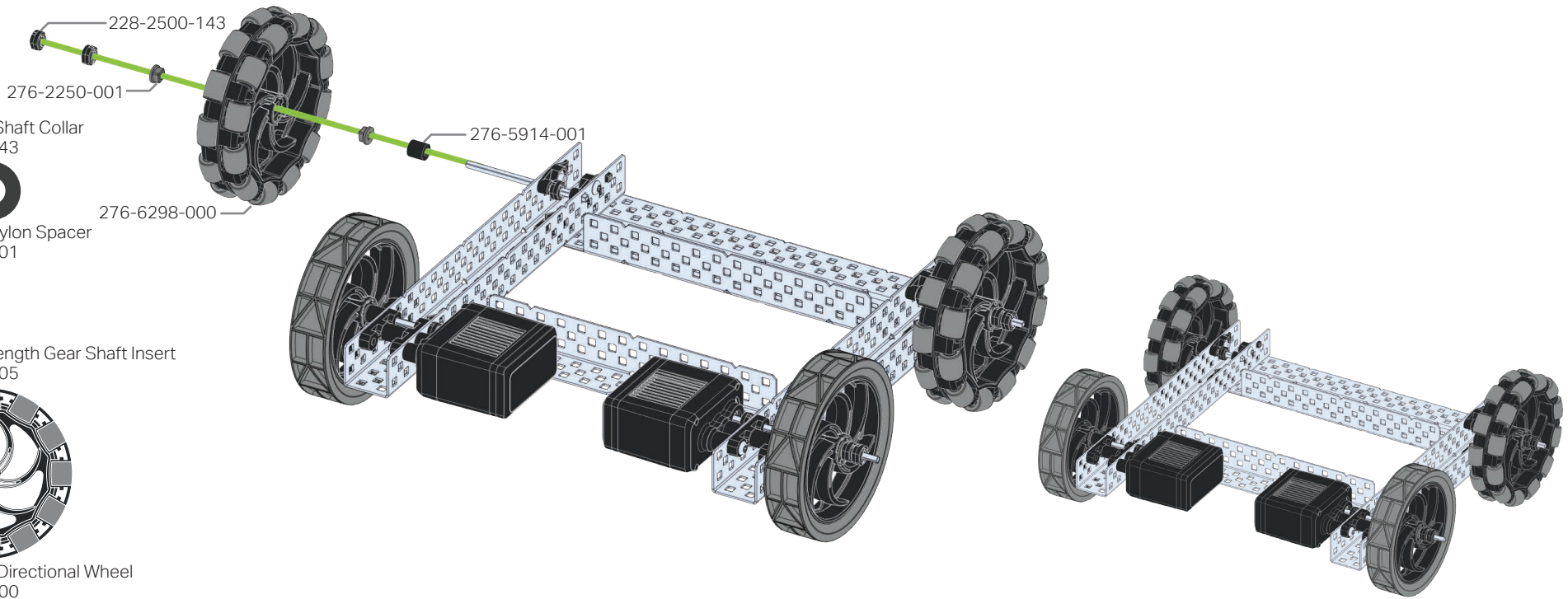

4x #8-32 Hex Nut
275-1028-001



4x #8-32 x 0.375"
Star Drive Screw
276-4991-001



2x V5 Battery Clip
276-6020-001

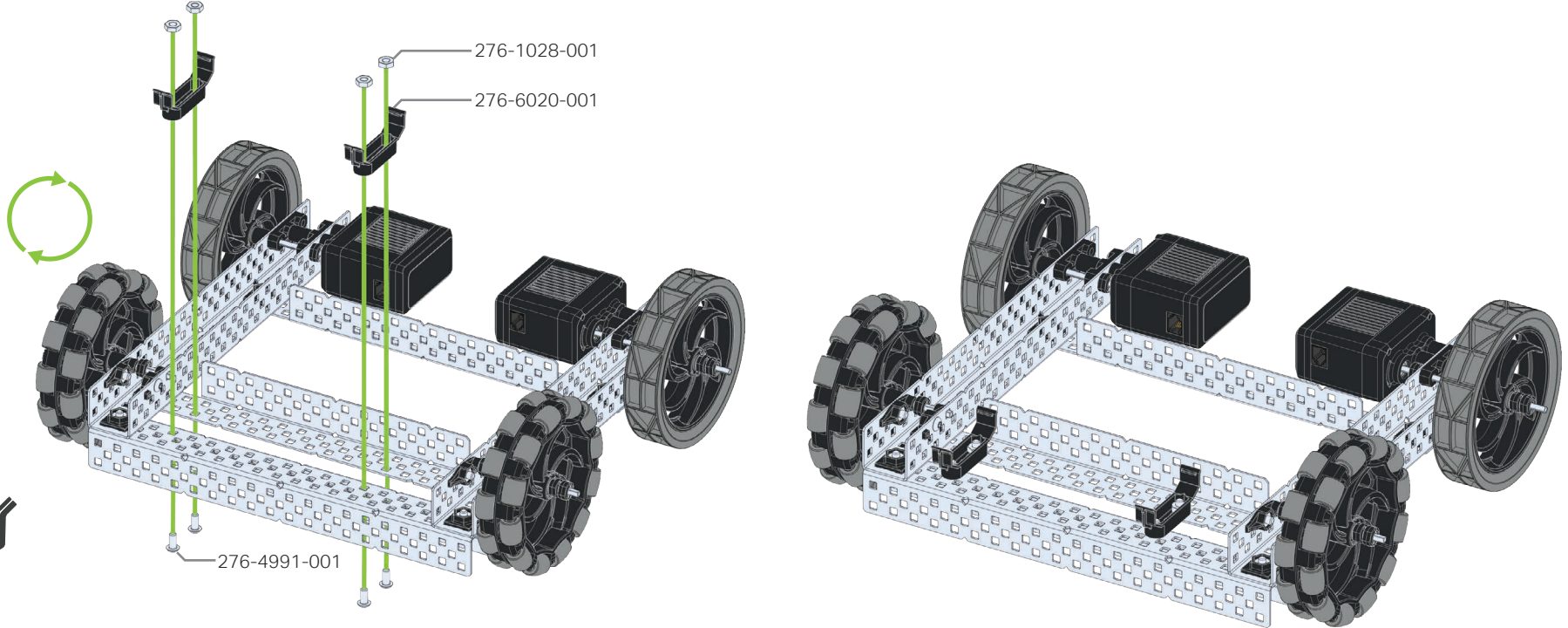

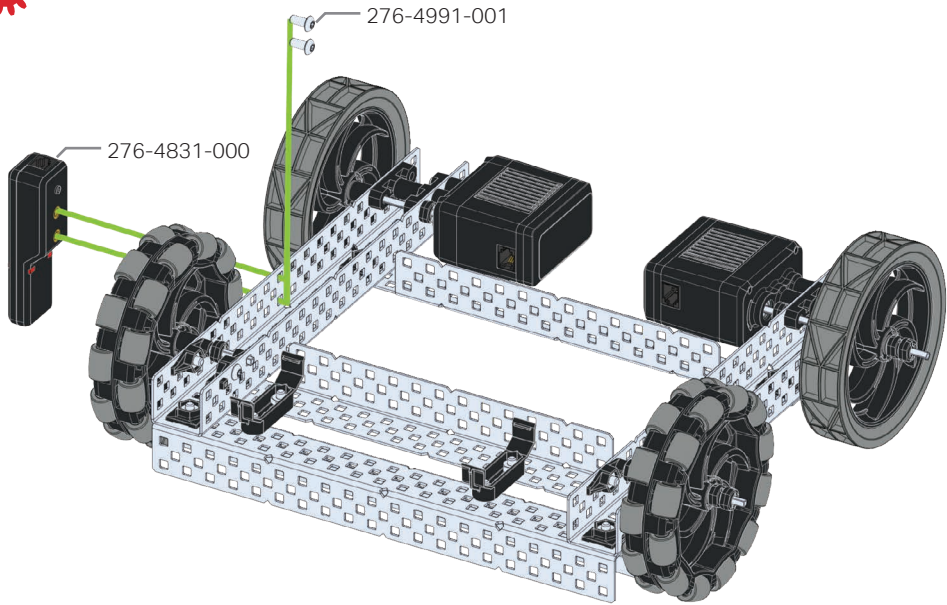

1x V5 Robot Radio
276-4831-000



2x #8-32 x 0.375"
Star Drive Screw
276-4991-001

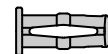
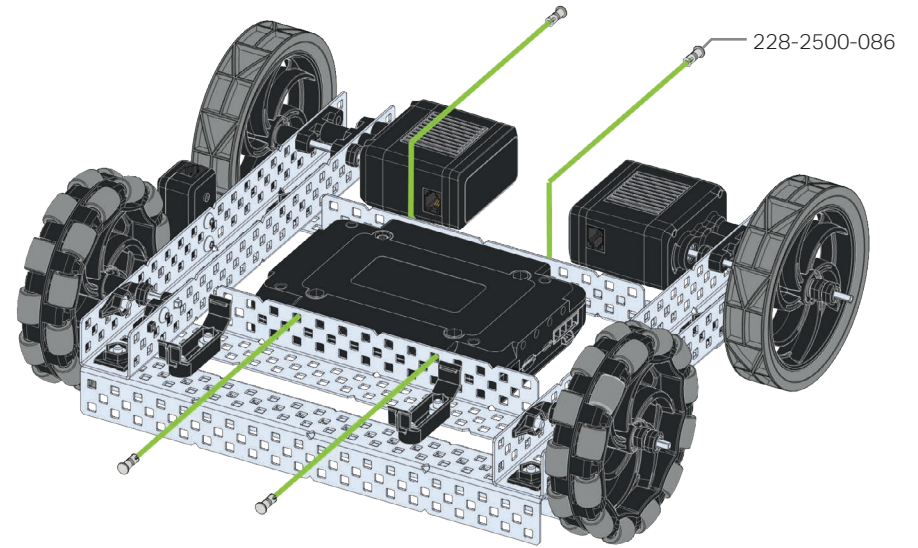
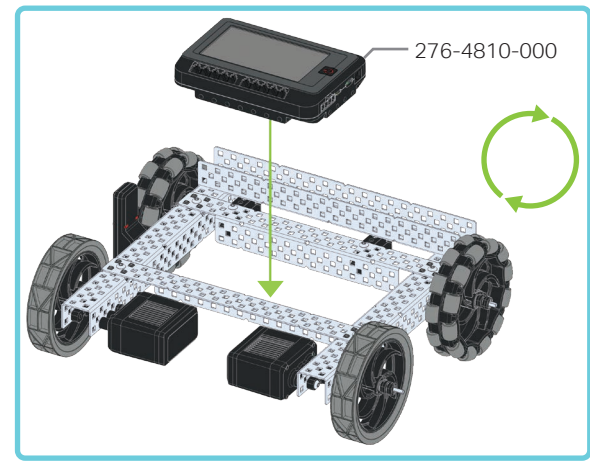

4x 0x1 Connector Pin
228-2500-086

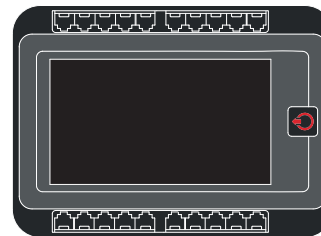

1x V5 Robot Brain
276-4810-000

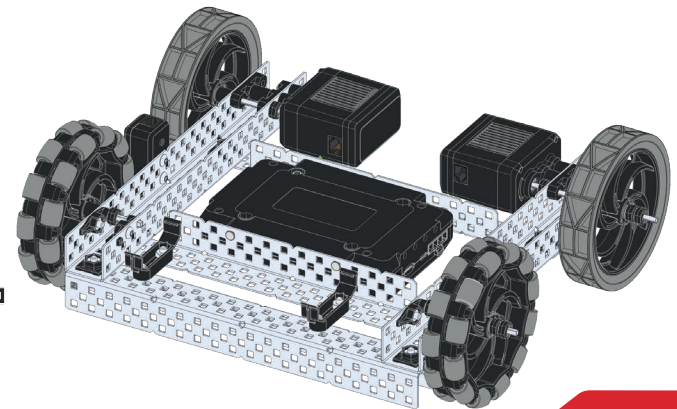

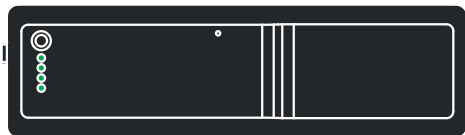
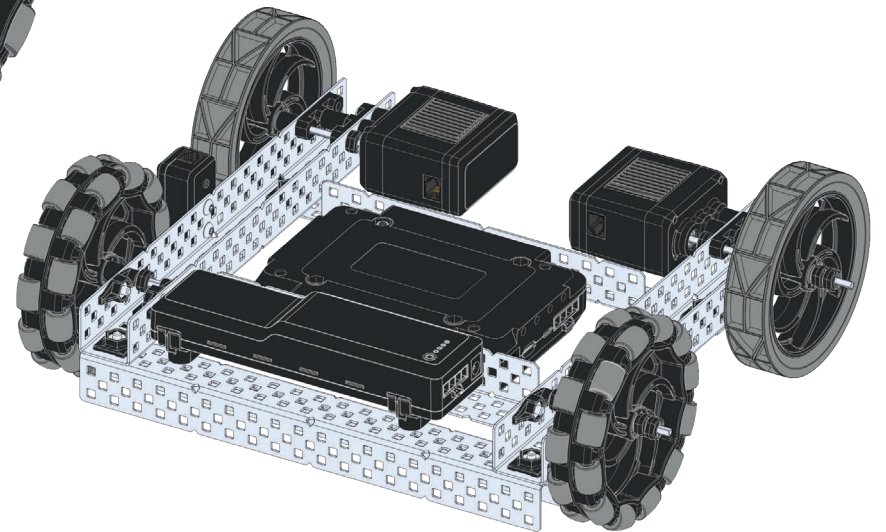
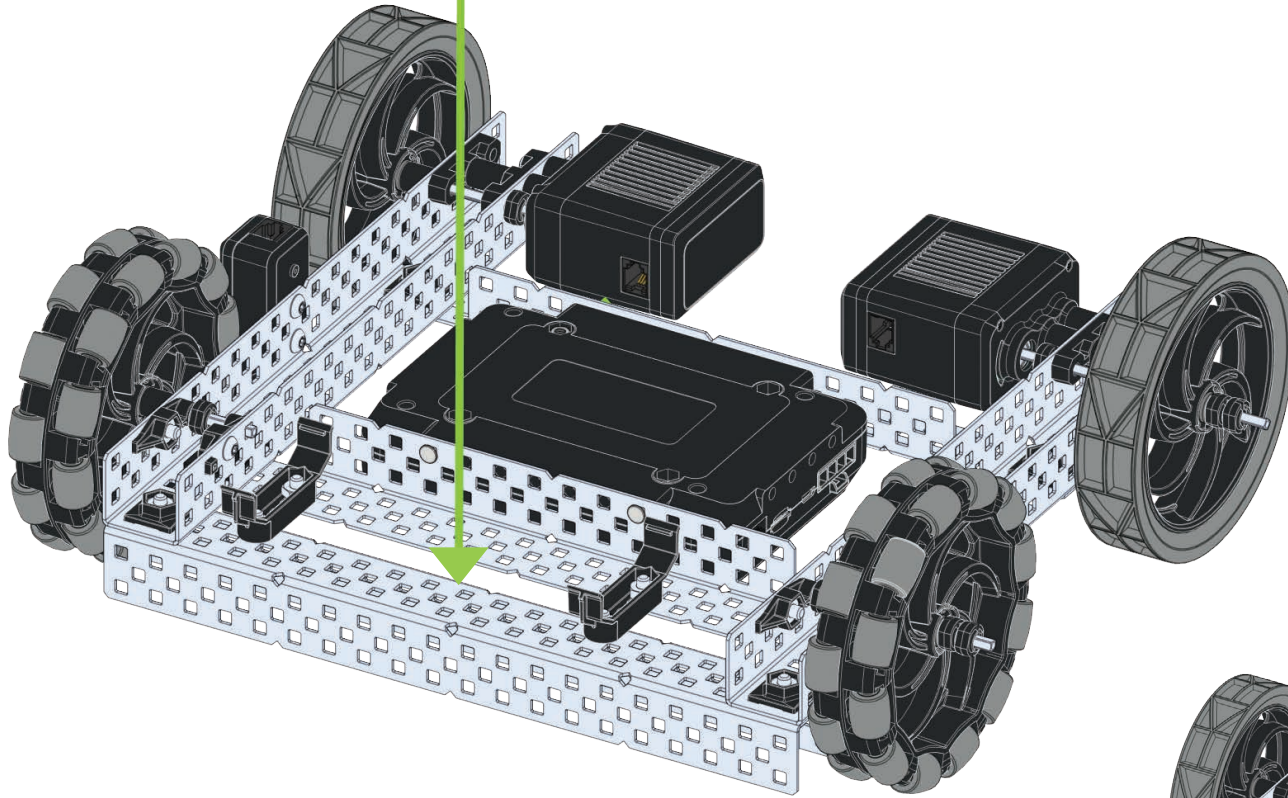
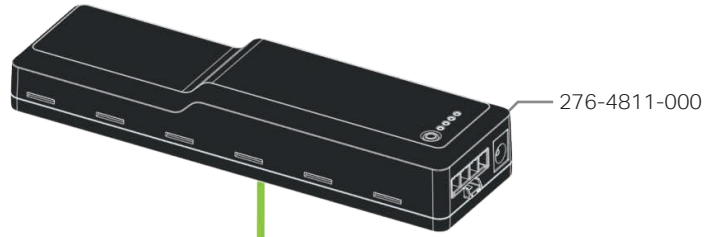

1x V5 Robot Battery Li-Ion 1100mAh
276-4811-000

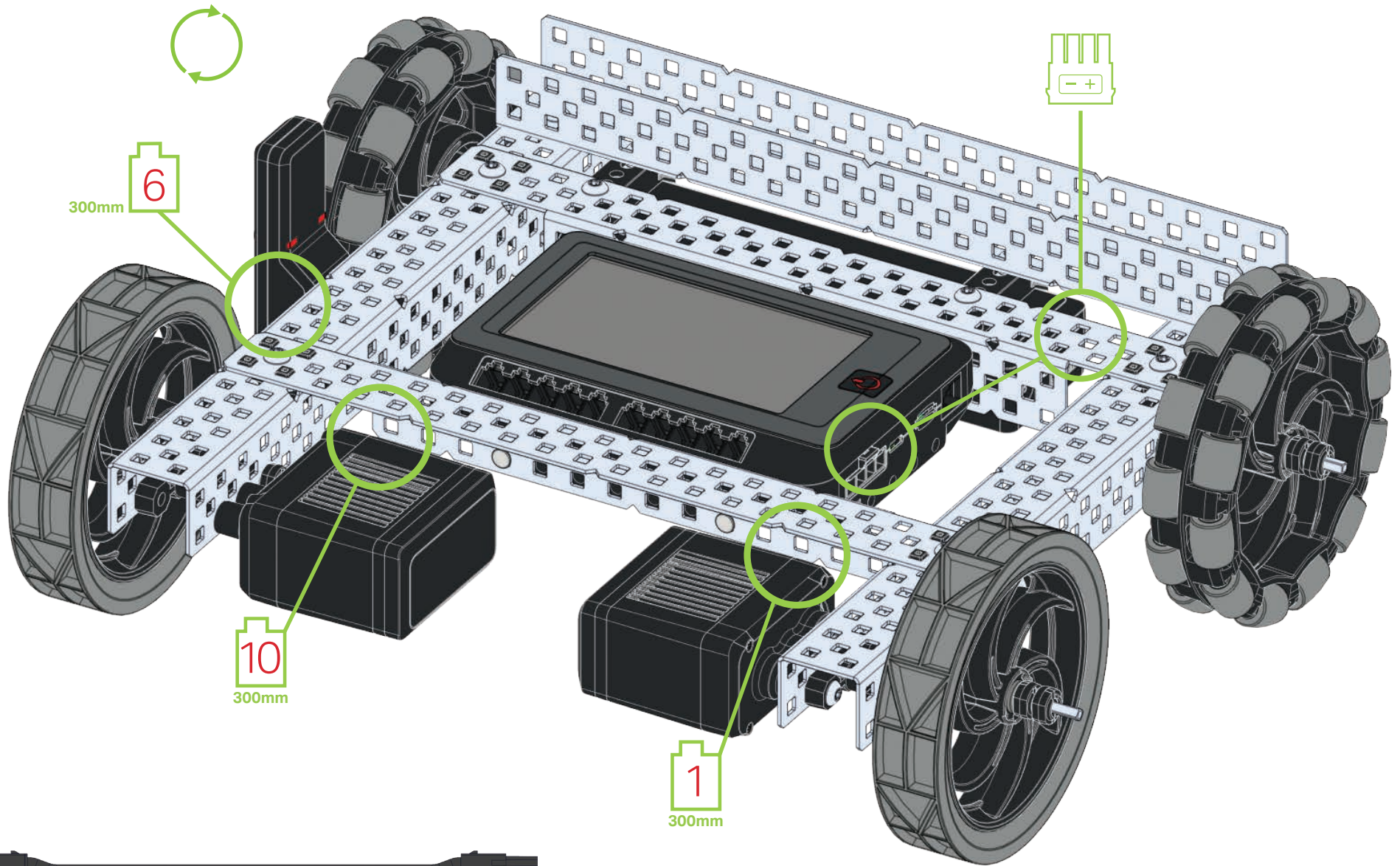

1x 180 mm V5 Power Cable
276-4817-100



3x 300 mm V5 Smart Cable
276-4860-020

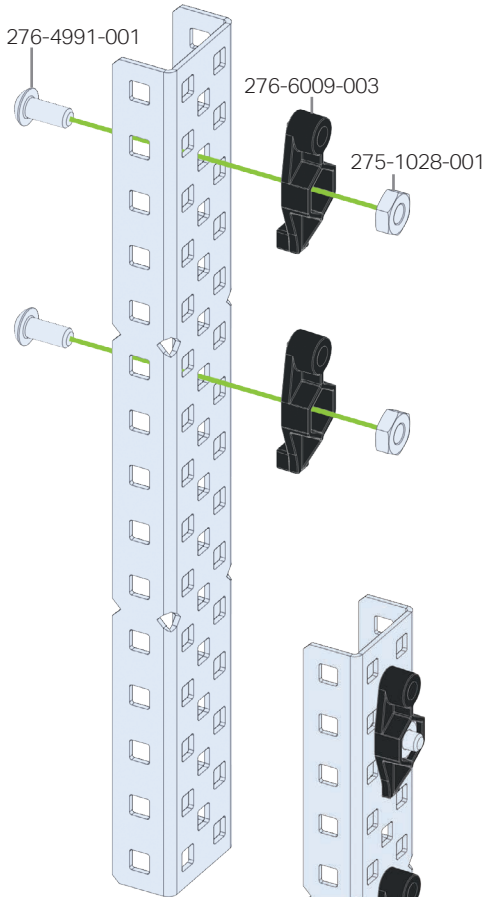

2x #8-32 x 0.375"
Star Drive Screw
276-4991-001

2x #8-32 Hex Nut
275-1028-001

2x 1-Post Hex Nut
Retainer with Bearing Flat
276-6009-003

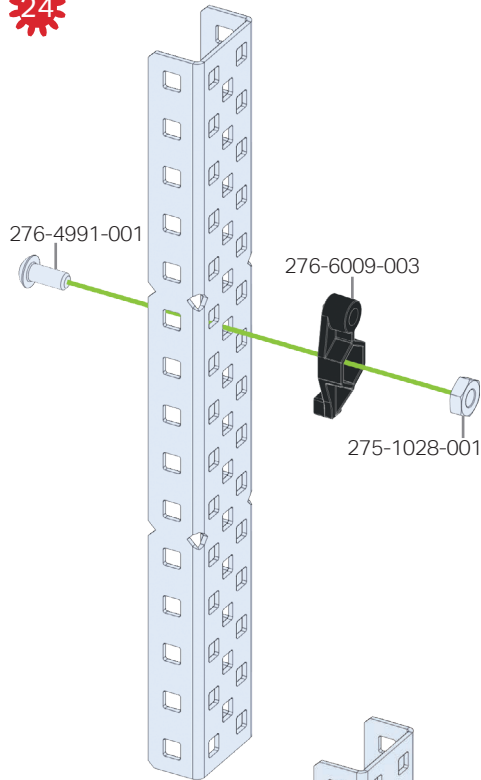

1x #8-32 x 0.375"
Star Drive Screw
276-4991-001

1x #8-32 Hex Nut
275-1028-001

1x 1-Post Hex Nut
Retainer with Bearing Flat
276-6009-003

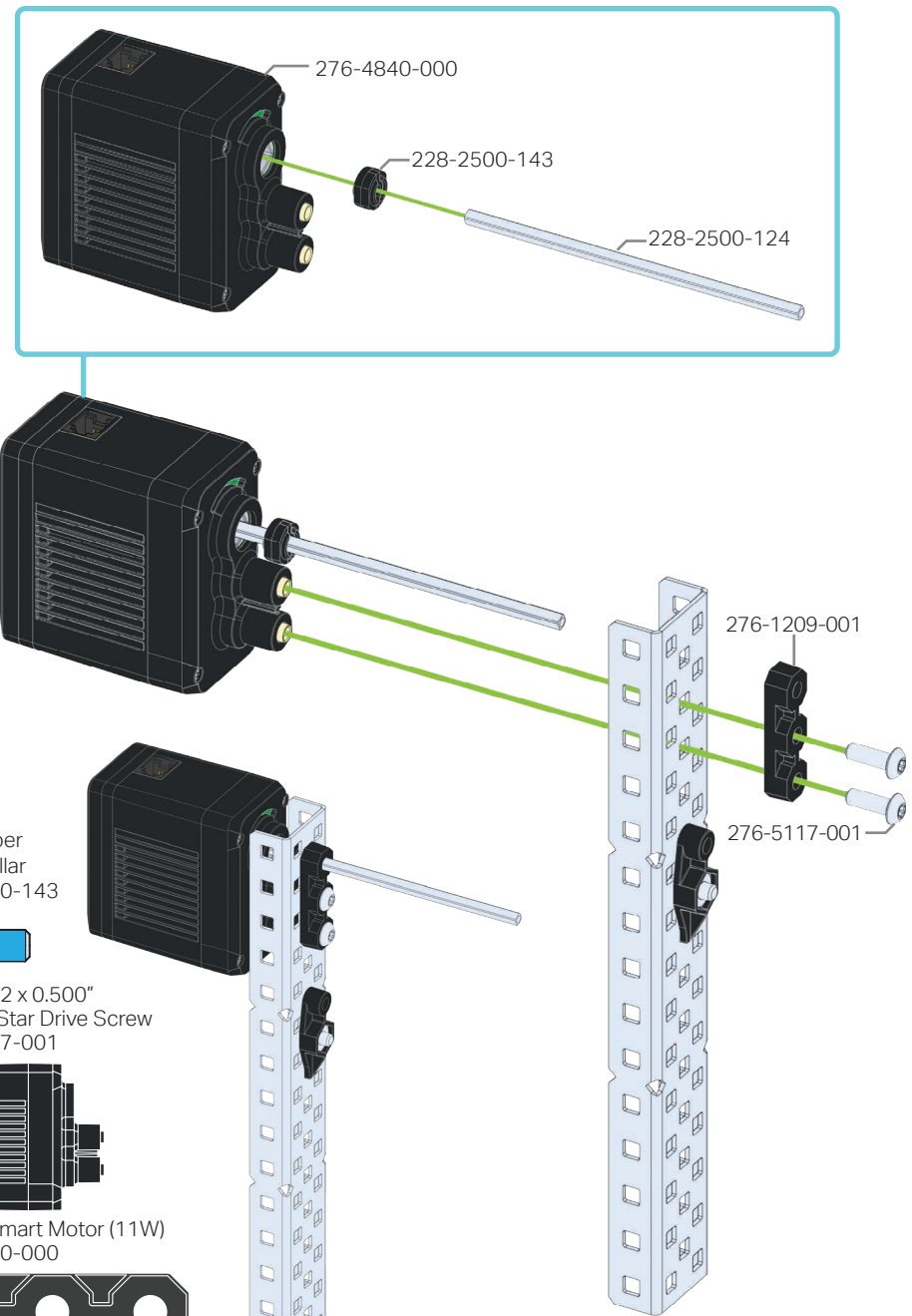

1x Rubber
Shaft Collar
228-2500-143

2x #8-32 x 0.500"
Locking Star Drive Screw
276-5007-001

1x V5 Smart Motor (11W)
276-4840-000

1x Bearing Flat
276-1209-001

1x 8x Pitch Shaft
228-2500-124

26

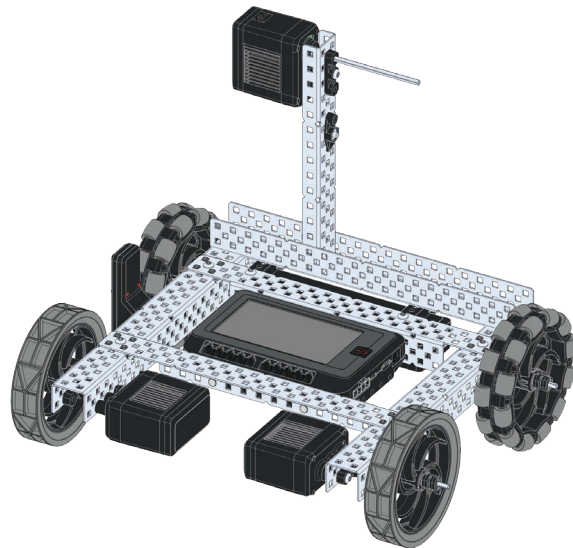
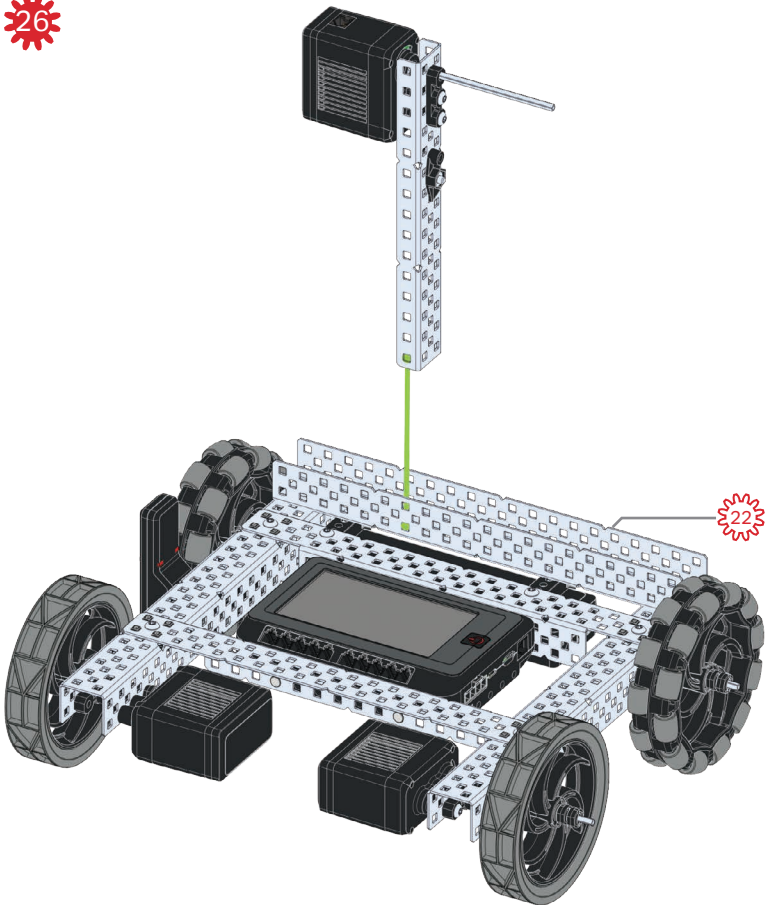

27

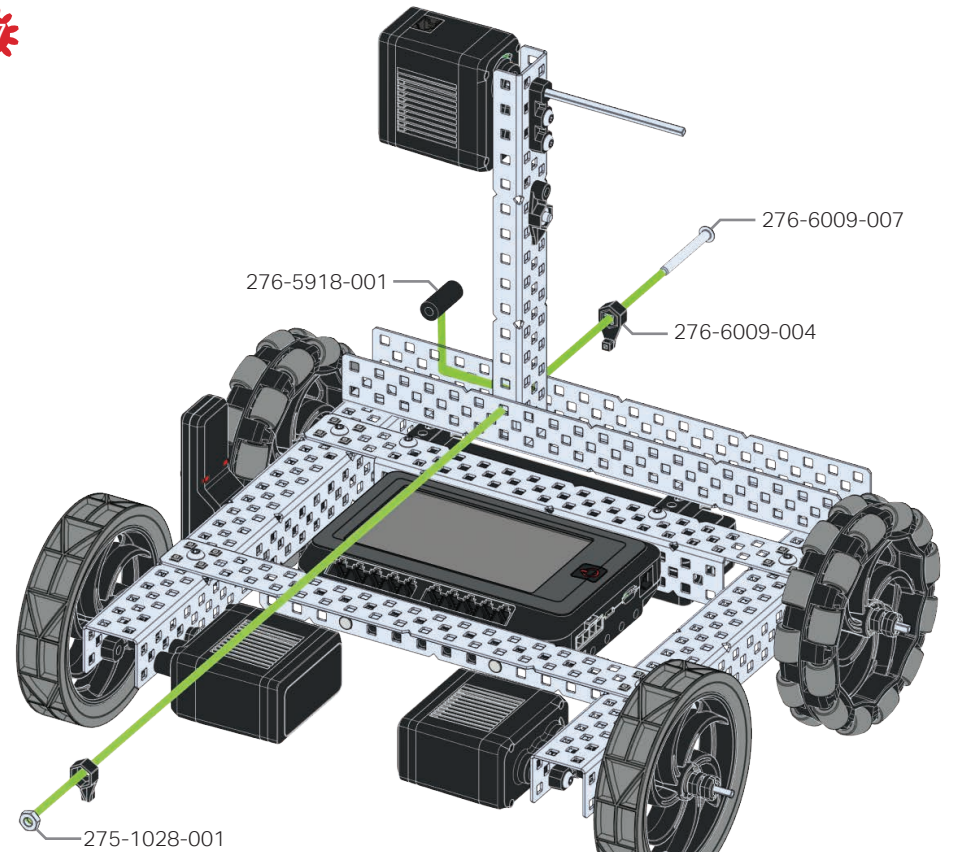

1x #8-32 Hex Nut
275-1028-001



2x 1-Post Hex Nut Retainer
276-6009-004



1x 0.875" Nylon Spacer
276-5918-001



1x #8-32 x 1.500" Locking
Star Drive Screw
276-6009-007

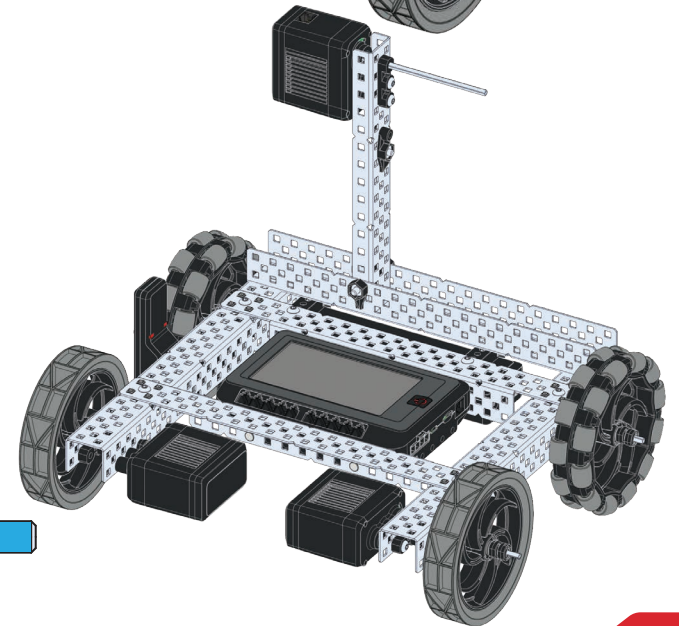

2X

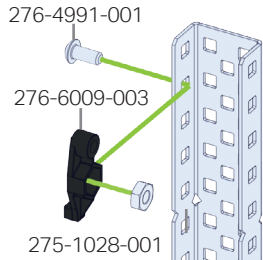

Cut
Hacksaw is required,
ask a parent/mentor
for help.

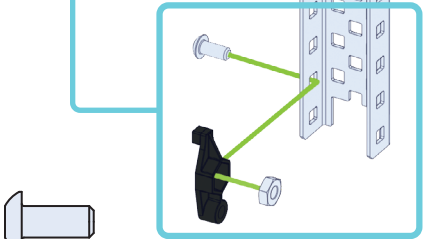

4x #8-32 x 0.375"
Star Drive Screw
276-4991-001

4x #8-32 Hex Nut
275-1028-001

4x 1-Post Hex Nut
Retainer with Bearing Flat
276-6009-003

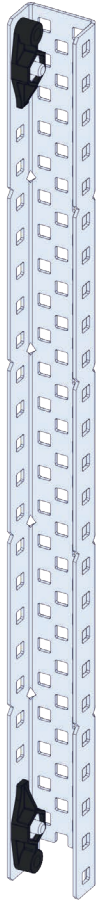

2X

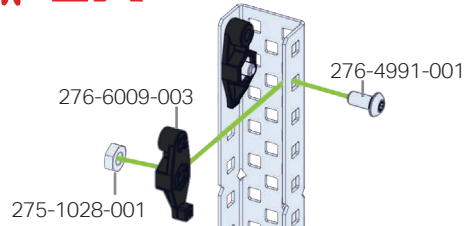

4x #8-32 x 0.375"
Star Drive Screw
276-4991-001

4x #8-32 Hex Nut
275-1028-001

4x 1-Post Hex Nut
Retainer with Bearing Flat
276-6009-003

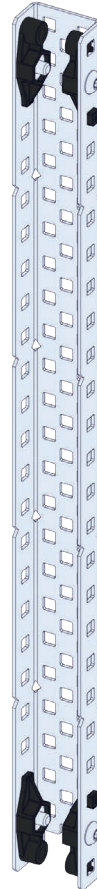

30

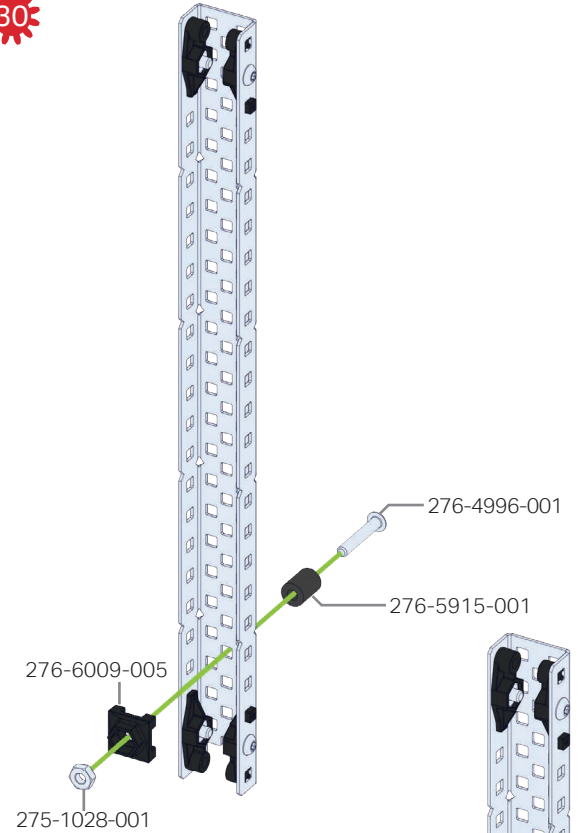

1x #8-32 Hex Nut
275-1028-001

1x 4-Post Hex Nut Retainer
276-6009-005

1x 0.500" Nylon Spacer
276-5915-001

1x #8-32 x 1.000" Star Drive Screw
276-4996-001

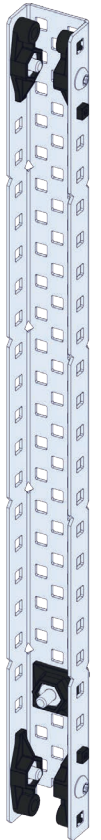

31

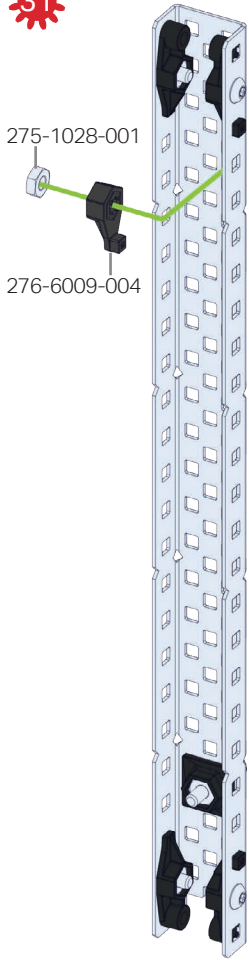

1x #8-32 Hex Nut
275-1028-001



1x 1-Post Hex Nut Retainer
276-6009-004

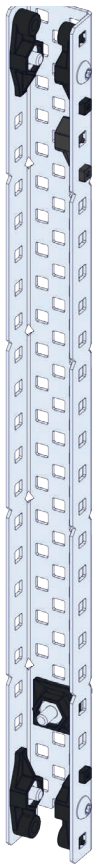

32

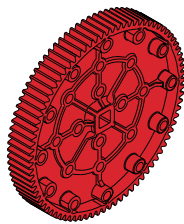
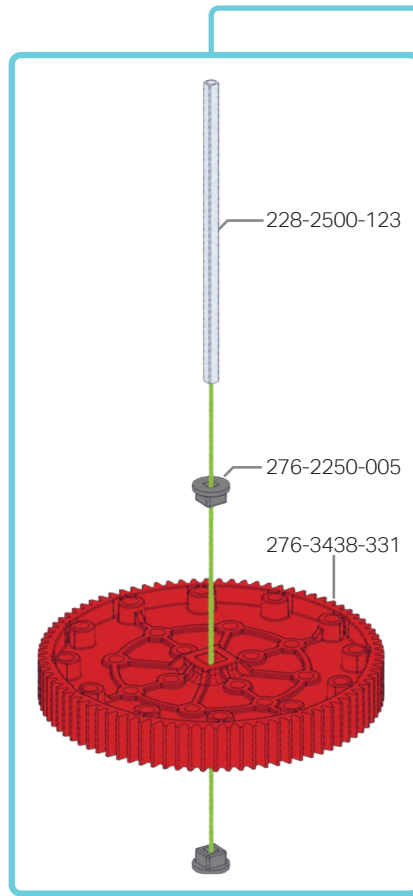

1x 84T High Strength Gear
276-3438-331



2x High Strength
Gear Shaft Insert
276-2250-005



1x #8-32 x 1.000"
Star Drive Screw
276-4996-001

1x 7x Pitch Shaft
228-2500-123

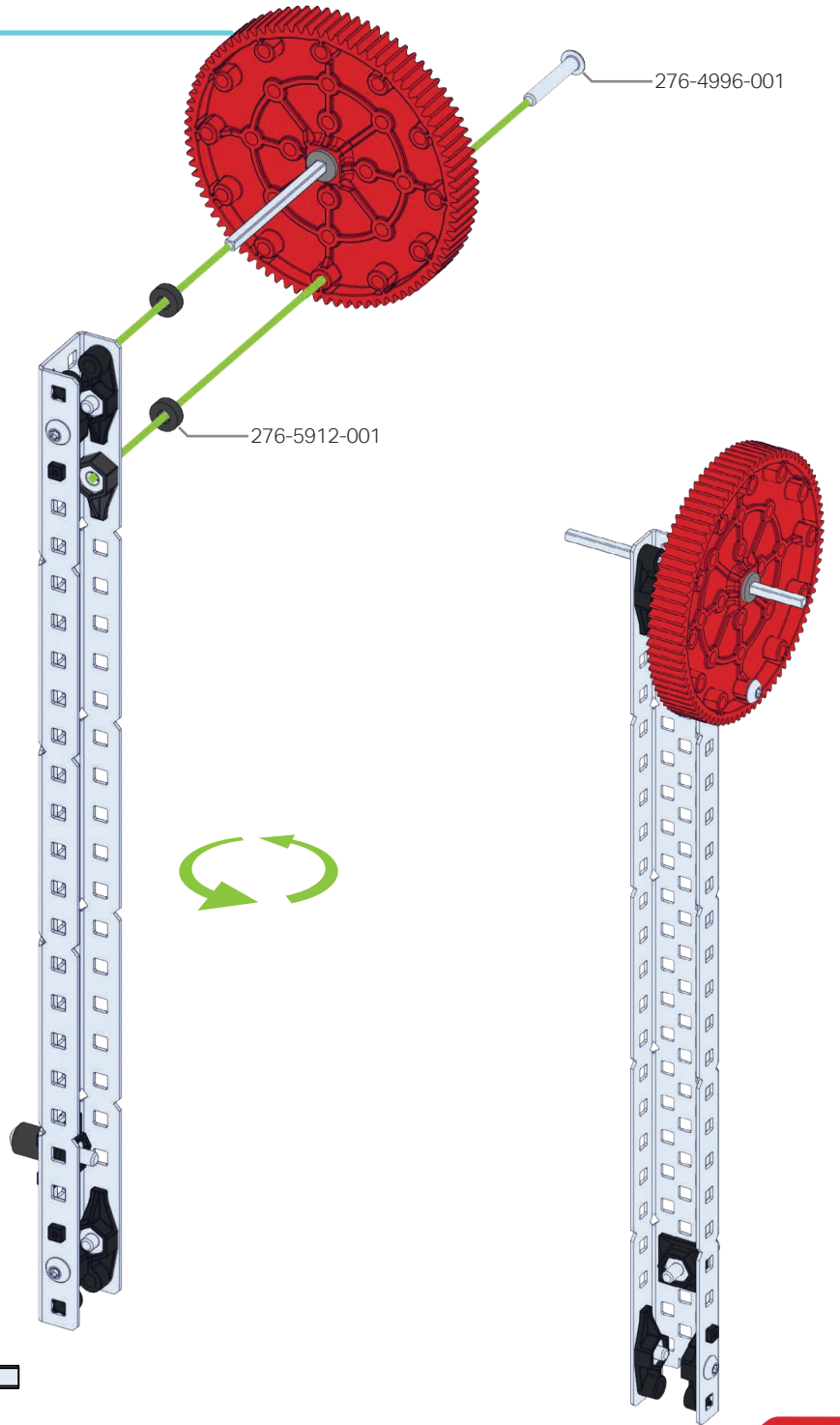

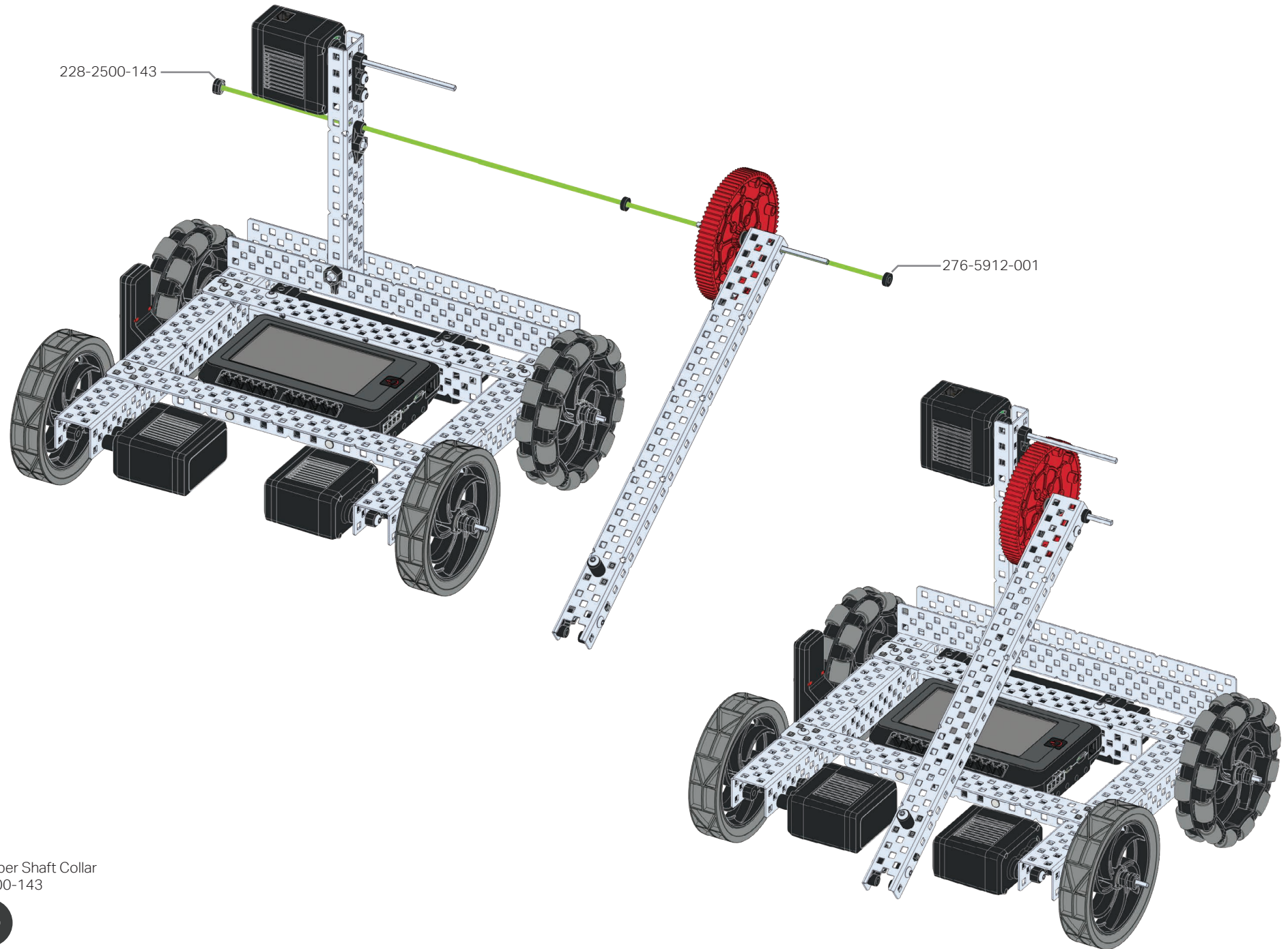

1x Rubber Shaft Collar
228-2500-143



2x 0.125" Nylon Spacer
276-5912-001

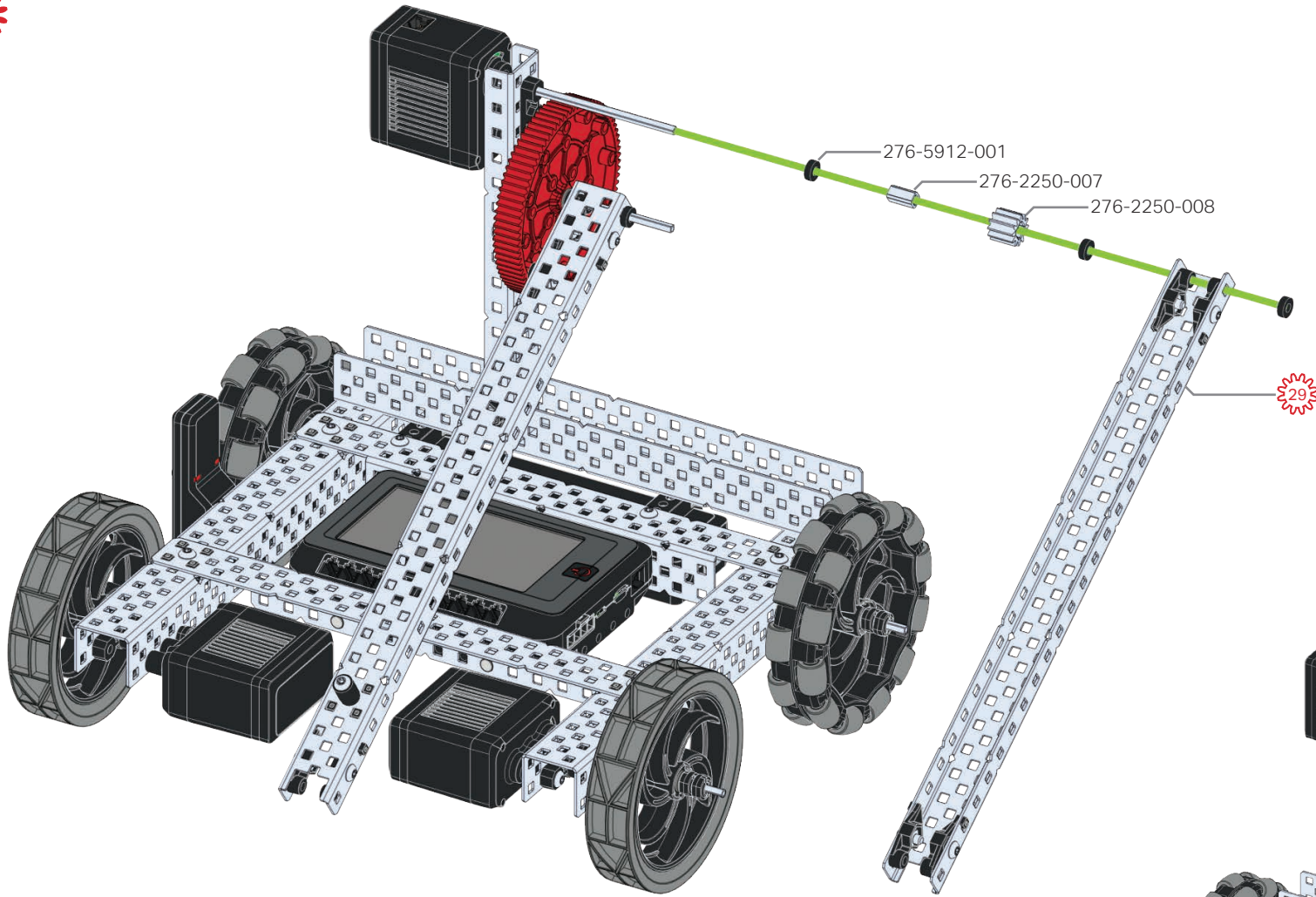

29

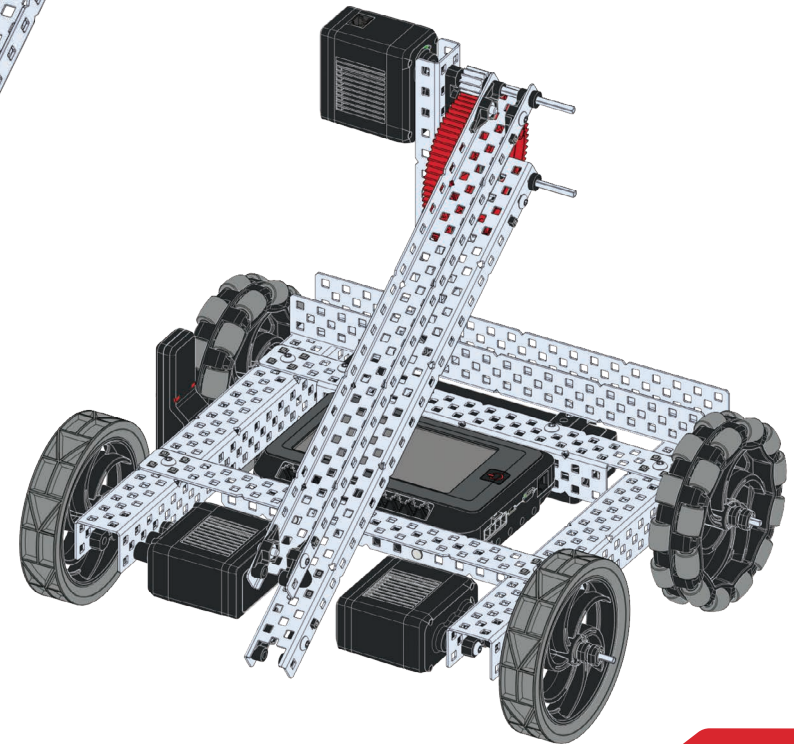

10

3x 0.125" Nylon Spacer
276-5912-001

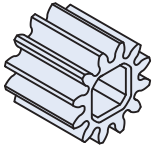

1x 12T Metal Pinion
276-2250-008



1x High Strength Shaft Adapter (1/8" Square Bore, 1/2" Long)
276-2250-007

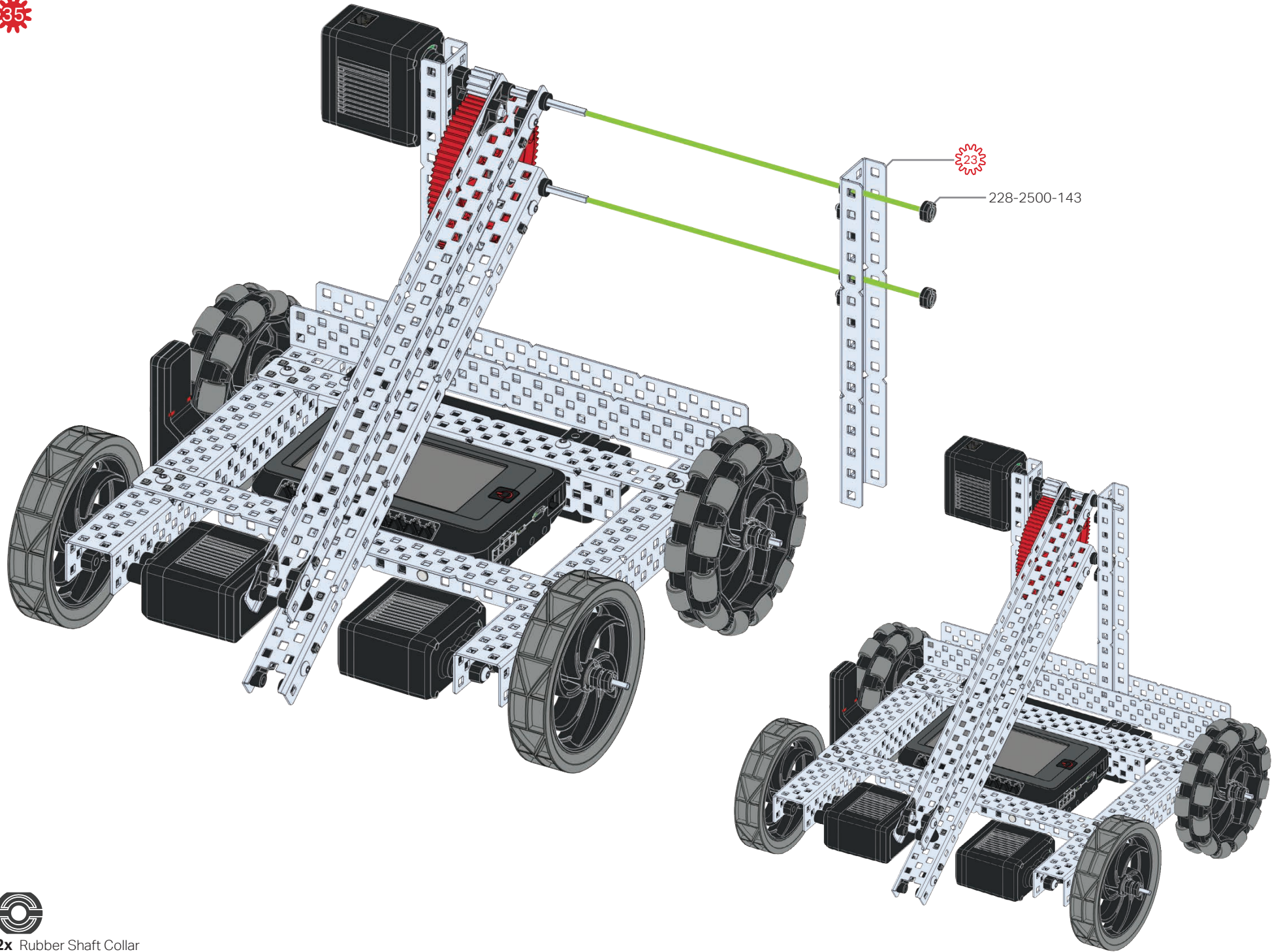

228-2500-143



2x Rubber Shaft Collar
228-2500-143

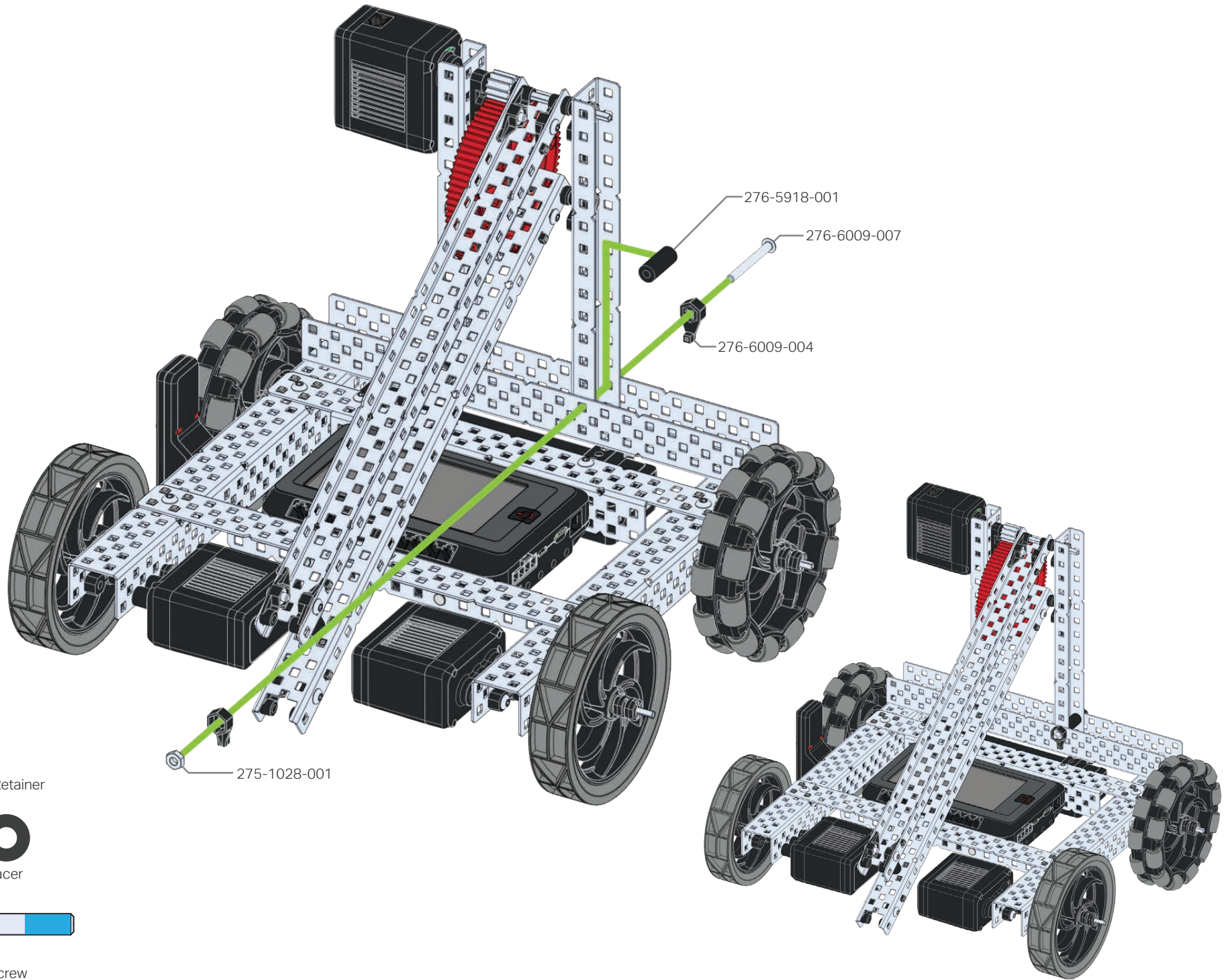

1x #8-32 Hex Nut
275-1028-001



2x 1-Post Hex Nut Retainer
276-6009-004



1x 0.875" Nylon Spacer
276-5918-001



1x #8-32 x 1.500"
Locking Star Drive Screw
276-6009-007

37

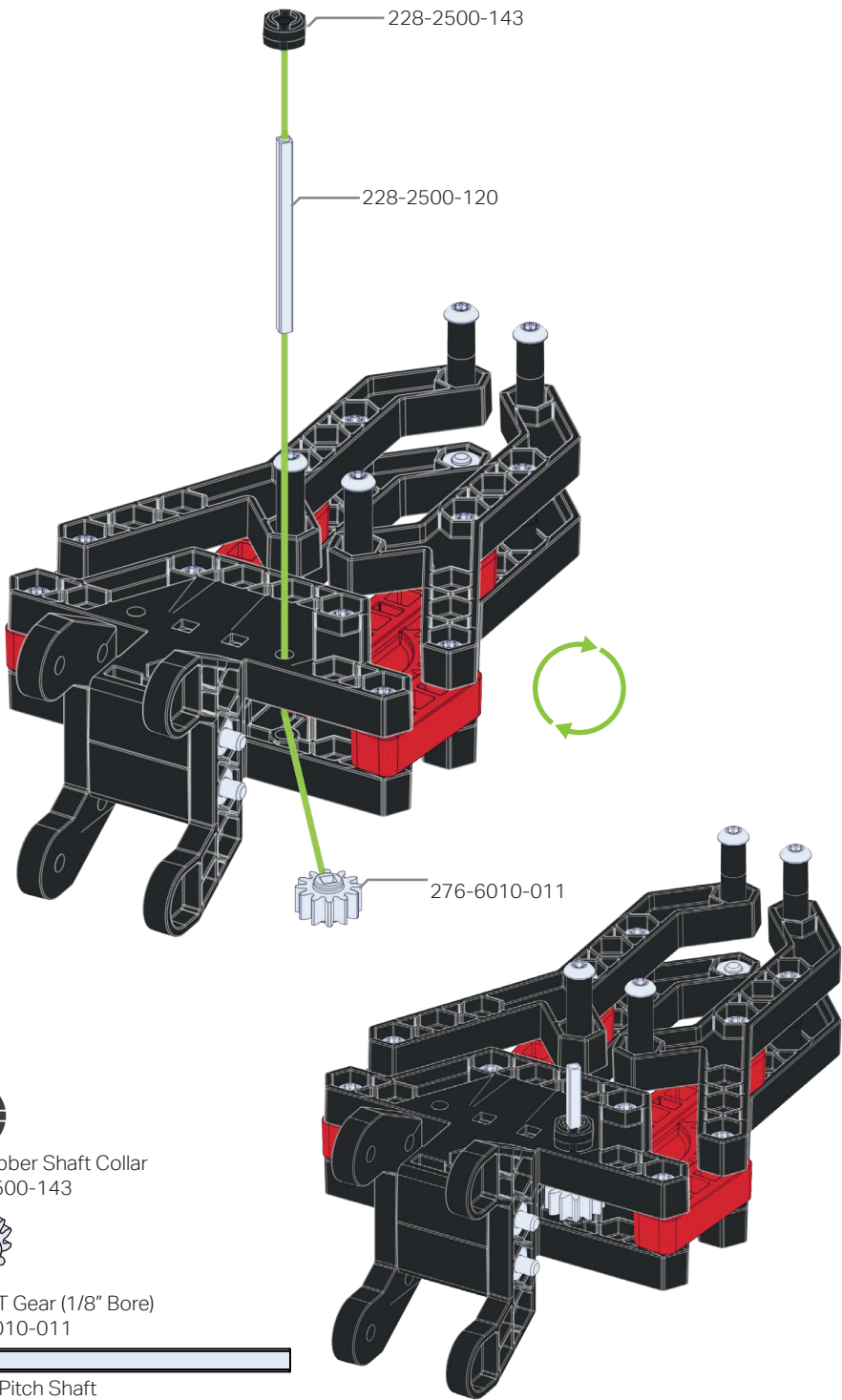

1x Rubber Shaft Collar
228-2500-143



1x 12T Gear (1/8" Bore)
276-6010-011



1x 4x Pitch Shaft
228-2500-120

38

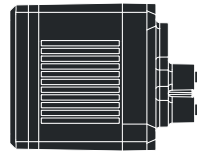
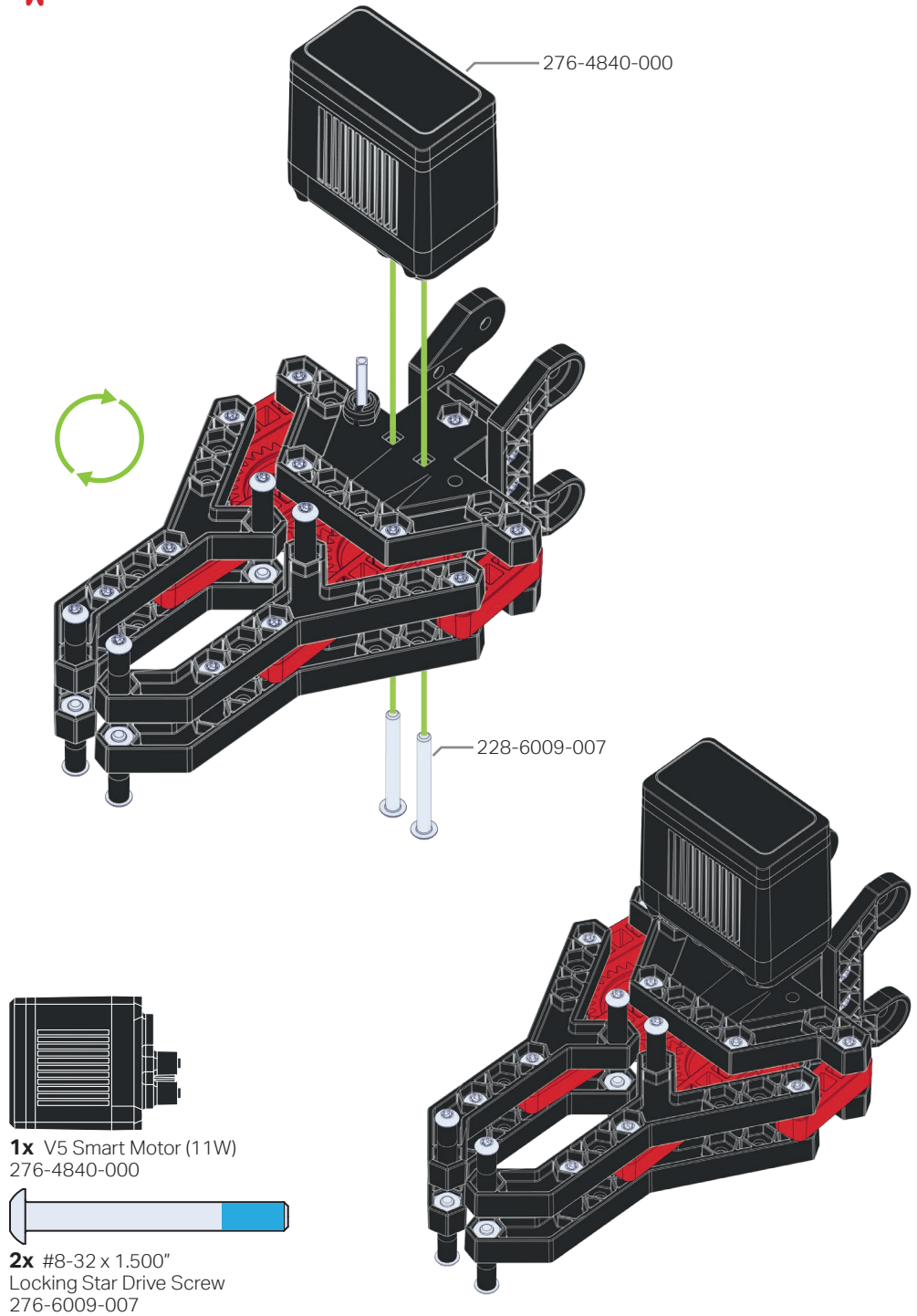

1x V5 Smart Motor (11W)
276-4840-000



2x #8-32 x 1.500"
Locking Star Drive Screw
228-6009-007

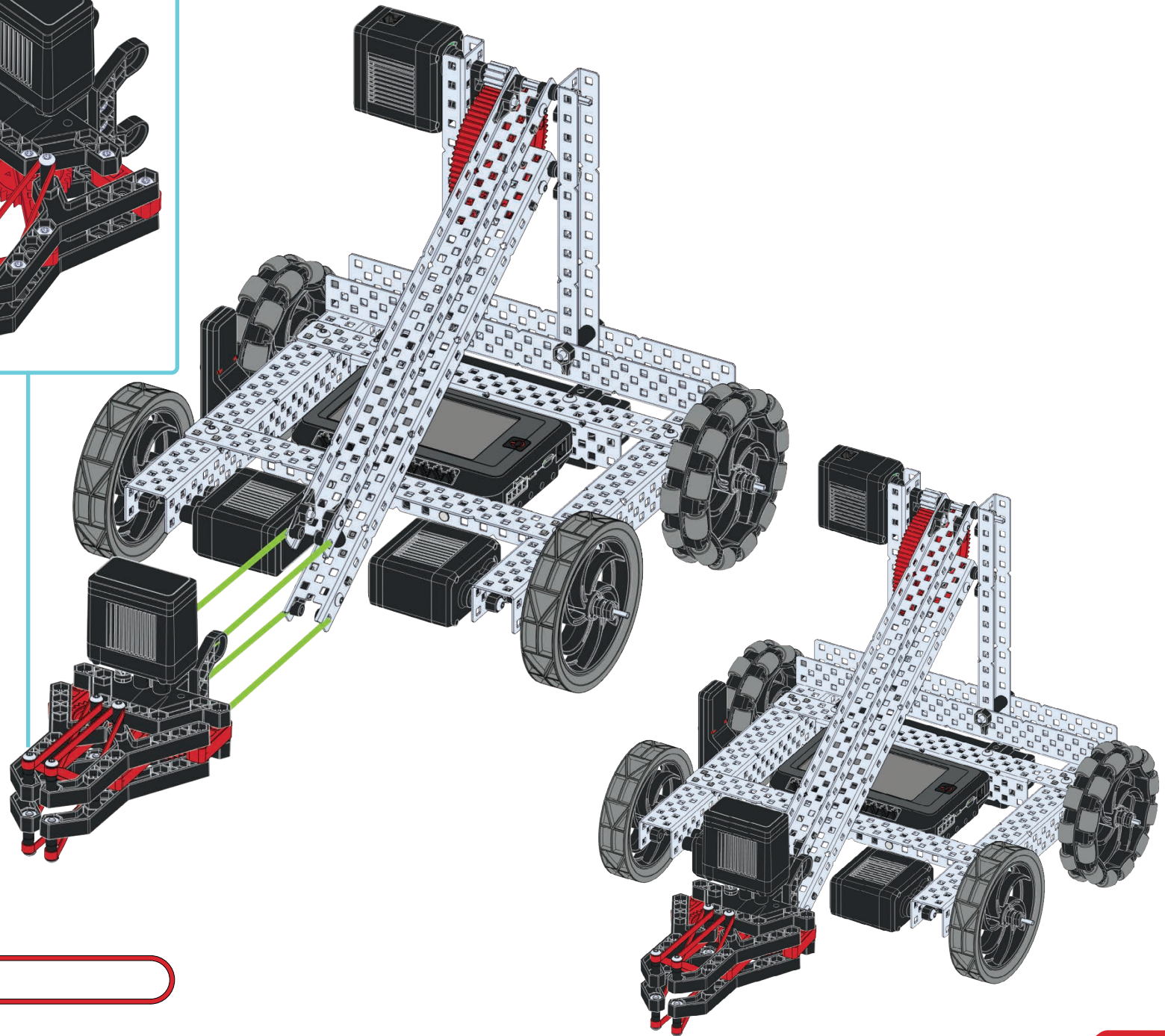
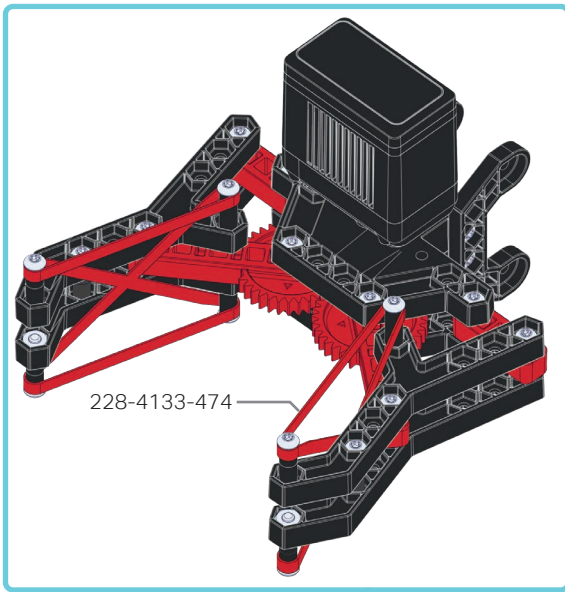

2x #32 Rubber Band
228-4133-474

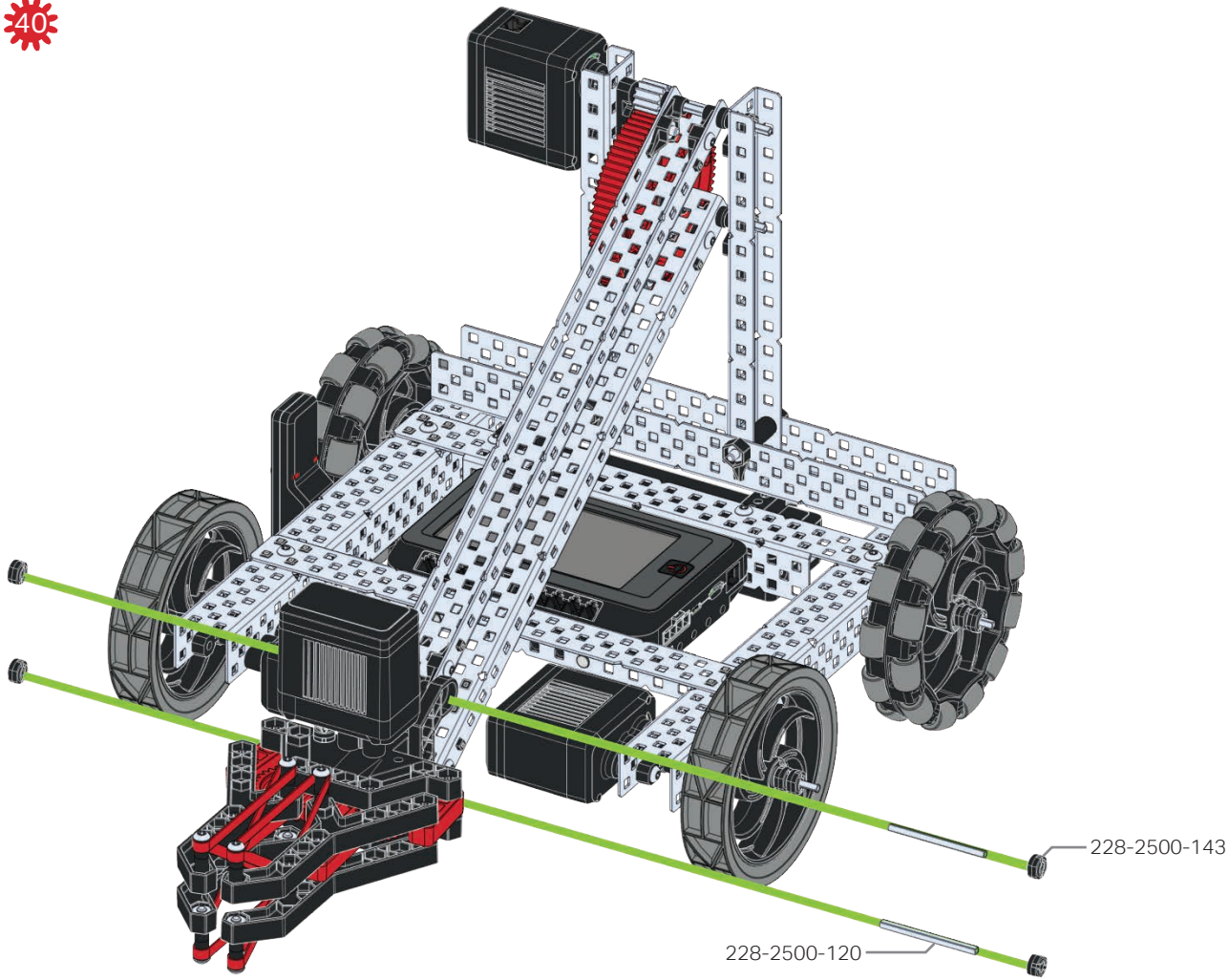

228-2500-143

228-2500-120

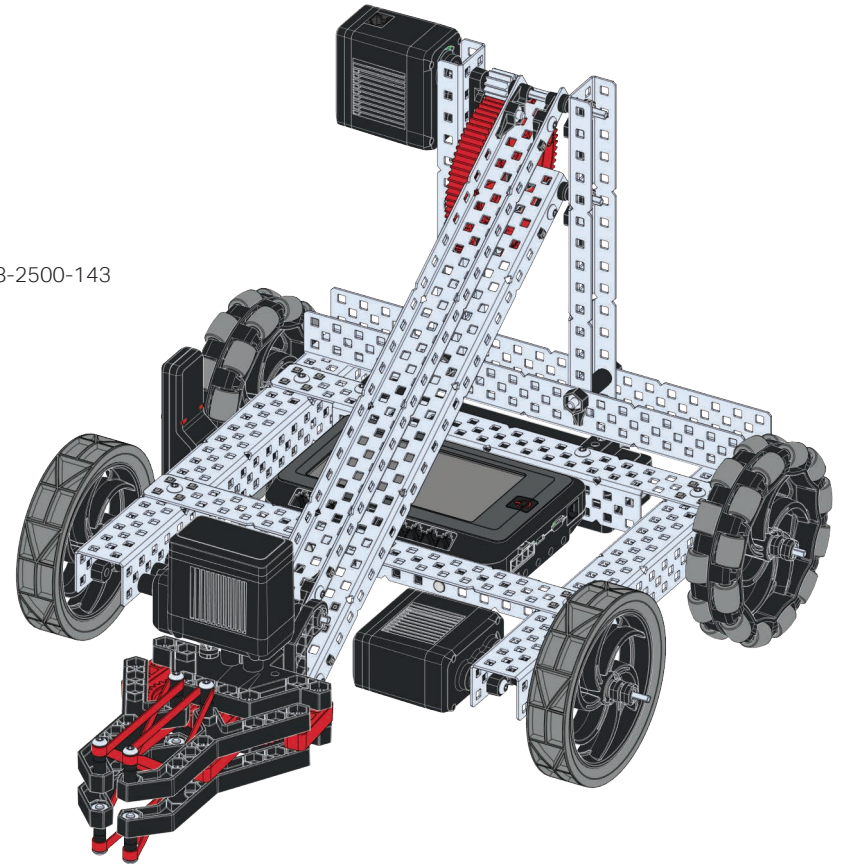

4x Rubber Shaft Collar
228-2500-143



2x 4x Pitch Shaft
228-2500-120

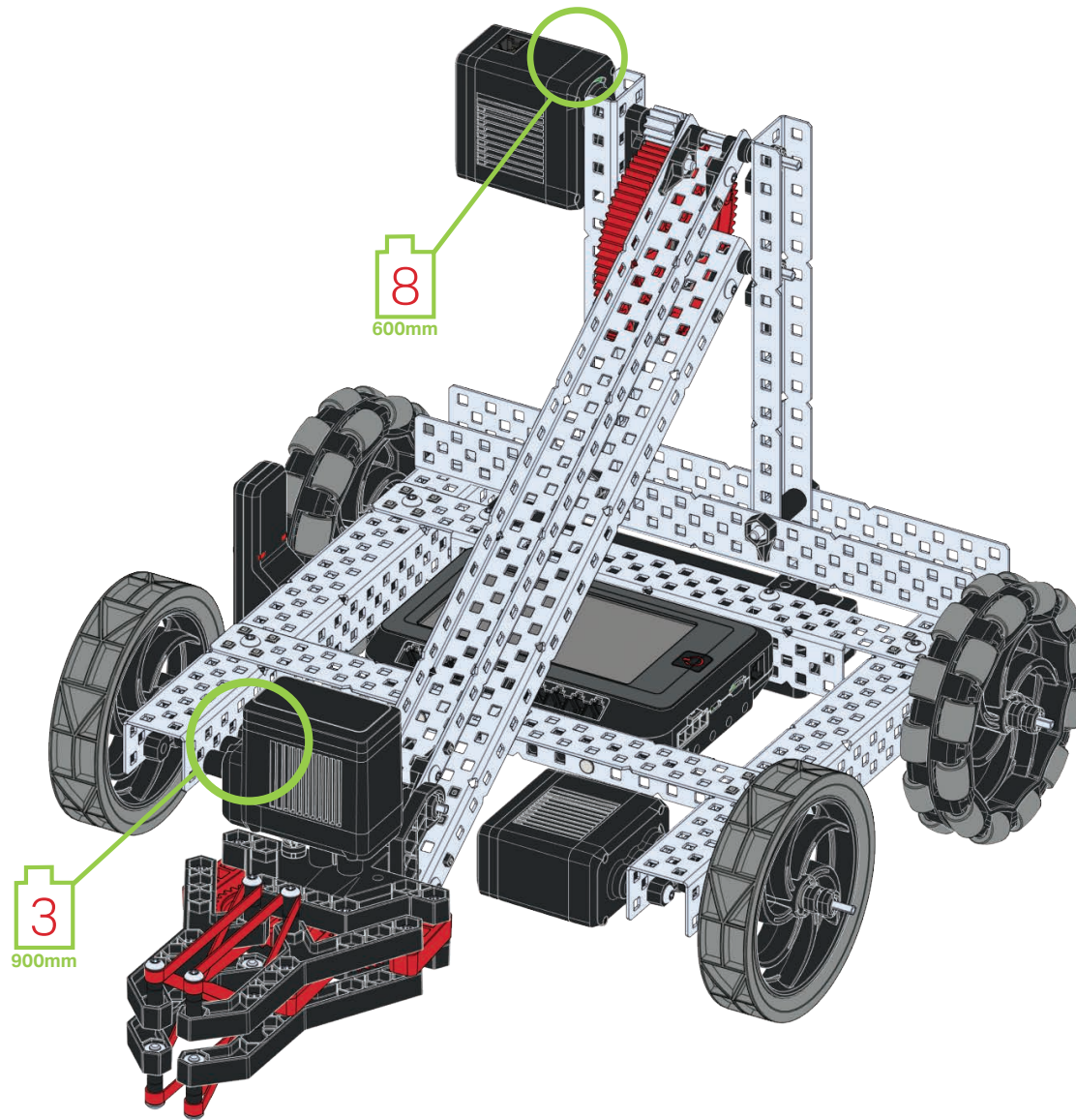

1x 900 mm V5 Smart Cable
276-4860-010



1x 600 mm V5 Smart Cable
276-4860-030

Clawbot Build Instructions

276-6009-750 Rev6



Custom manufactured in China for Innovation First Trading SARL. Distributed in the U.S.A, Mexico, Caribbean, Central & South America by VEX Robotics, Inc., 6725 W. FM 1570, Greenville, TX 75402, U.S.A. Distributed in China by Innovation First International (Shenzhen), Ltd., Suite 1205, Galaxy Development Center, 18 Zhongxin 5th Road, Futian, Shenzhen, Guangdong, China 518048. Distributed in other regions by Innovation First Trading SARL, Z.A.E. Wolser G, 315, 3434 – Dudelange, Luxembourg +352 27 86 04 87. Distributed in Canada by / Distribué au Canada par / Innovation First Trading, LLC, 6725 W. FM 1570, Greenville, TX 75402, U.S.A. ©2023 VEX Robotics, Inc. All rights reserved. Tous droits réservés.