

# PERRIN

## PERFORMANCE

### 2005-14 WRX/STI Steering Rack Lock Down

2014-05-20

Thank you for purchasing this PERRIN product for your car! Installation of this product should only be performed by persons experienced with installation of aftermarket performance parts and proper operation of high performance vehicles. If vehicle needs to be raised off the ground for installation, the installer must use proper jacks, jack-stands and/or a professional vehicle hoist for safety of the installer and to protect property. If the vehicle is lifted improperly, serious injury or death may occur! Please read through all instructions before performing any portion of installation. If you have any questions, please contact our tech department prior to starting installation. We can be reached in any of the following methods:

Email [Tech@PERRINperformance.com](mailto:Tech@PERRINperformance.com)

Instant Chat off the main page of [www.PERRINperformance.com](http://www.PERRINperformance.com)

Or simply call our tech team at 503-693-1702

#### SUSPENSION INSTALLATION NOTE

Installation of this product is a modification to the vehicle suspension. As a result, the vehicle may handle differently than that of factory-equipped vehicles. As with any vehicle extreme care must be used to prevent loss of control or roll-over during sharp turns or abrupt maneuvers. Always wear seat belts, and drive safely, recognizing that reduced speeds and specialized driving techniques may be required. Failure to drive this vehicle safely may result in serious injury or death. Do not drive this vehicle unless you are familiar with its unique handling characteristics and are confident of your ability to maintain control under all driving conditions. Some modifications (and combinations of modifications) are not recommended and may not be permitted in your state or country. Consult your owner's manual, service manual, instructions accompanying this product, and local laws before undertaking these modifications. You are responsible for the legality and safety of the vehicle you modify using these components.

#### Parts Included with Steering Rack Lock Down:

- (4) Urethane Bushings
- (2) Steel Sleeves
- (1) Bushing Removal Tool
- (1) M10x80 Bolt
- (1) M10 Nut
- (1) 3/8" Washer
- (1) Urethane Grease Packet

#### Installation

1. Raise front of vehicle off ground using proper jack and jack stands. Never work under a car solely supported by jack, death or injury may occur.
2. Remove lower splash guard from car. This step will vary greatly from car to car, please see service manual as to how to complete this step.
3. Locate and remove Jack plate on center of engine cross member. Remove 14mm bolts securing it to cross member. **Note: 2005-2007 has (8) bolts to remove and 2008+ has (10) bolts to remove.**

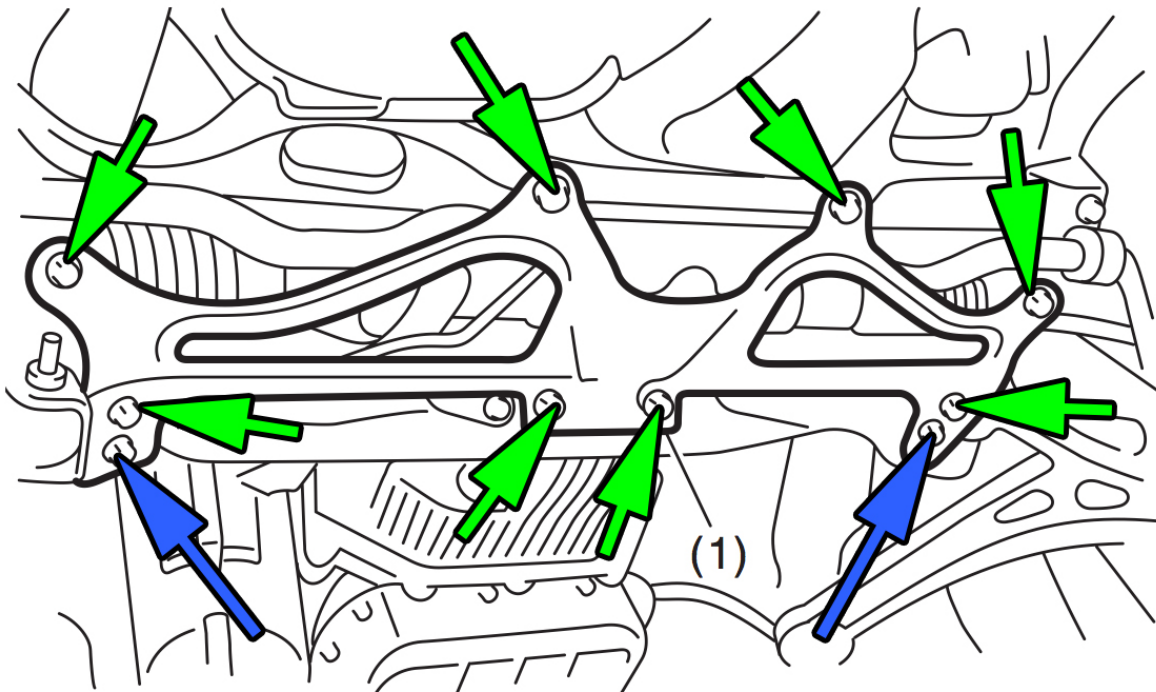

- Using a grease pen or paint pen, locate steering rack universal joint where it connects to steering rack. Make a mark across spline and joint as shown below. This indicates the correct orientation of the steering wheel to steering rack.
- Remove 12mm bolt holding steering rack universal joint to steering rack.



- Remove (4) 14mm bolts holding left side of steering rack to chassis. **Note: Take note of orientation of bracket removed during this step.**

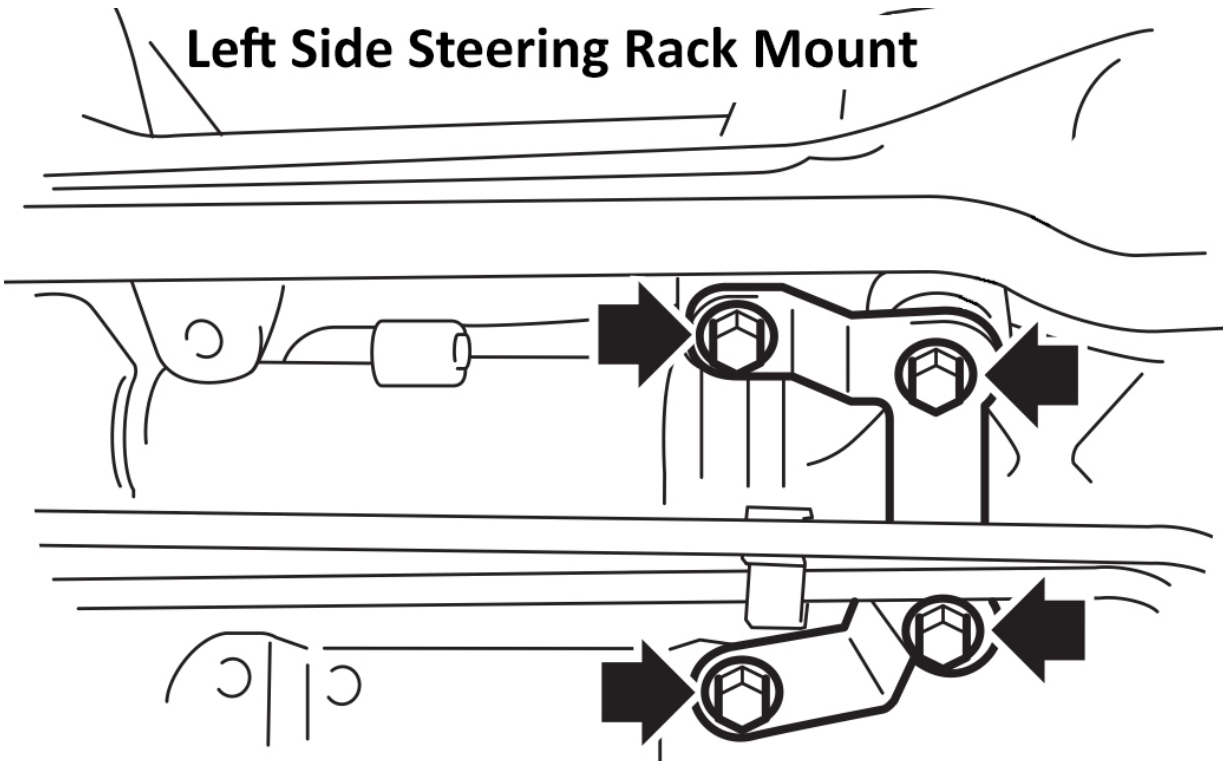

- Remove (2) 14mm bolts holding right side of steering rack to chassis.

## Right Side Steering Rack Mount

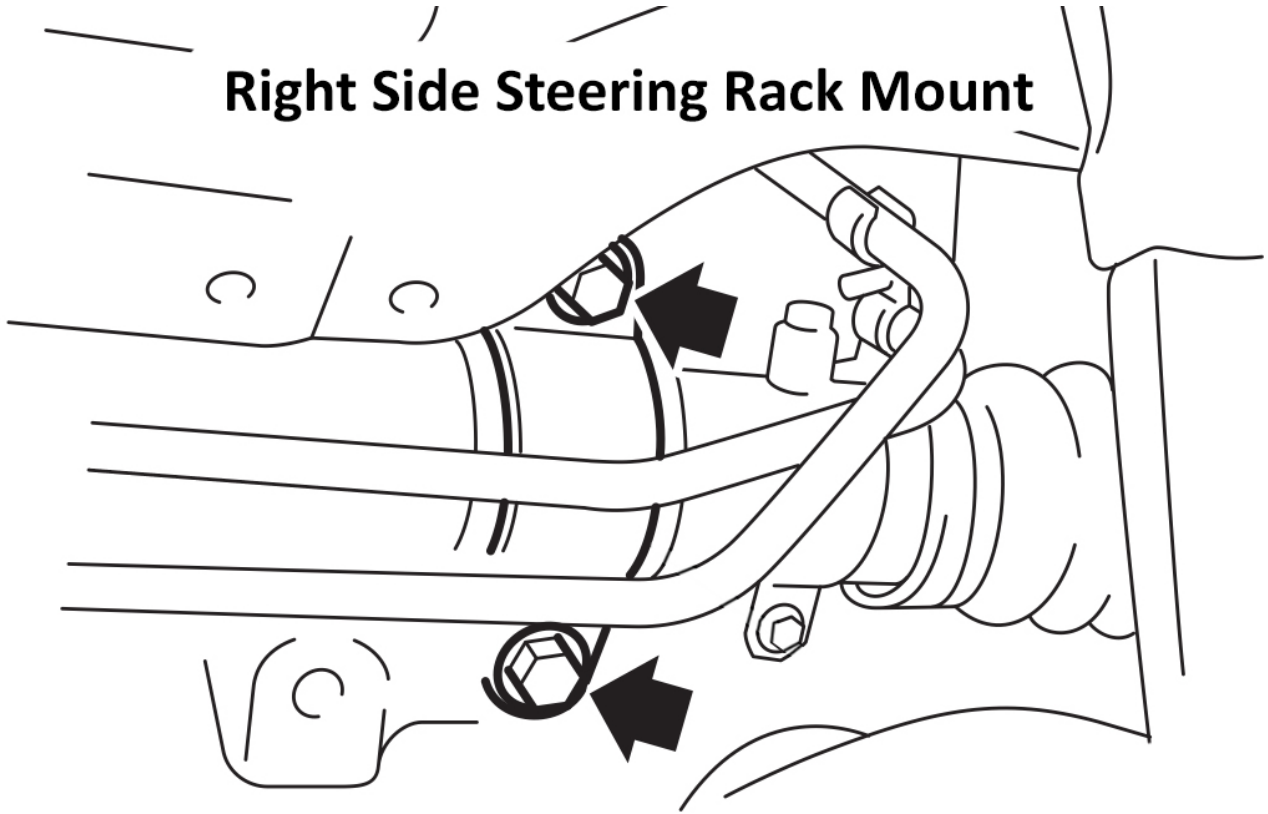

8. Carefully pull down on left side of steering rack, and wiggle the universal joint to free steering rack from chassis. **Note: DO NOT move the steering wheel after this is done. A small amount of movement is ok as this will be corrected by lining up the painted mark.**
9. Pull rack down roughly 2 inches. Place supplied M10 nut and wrench centered on top of bushing.
10. Install supplied bushing removal tool over bottom side of bushing, and thread supplied M10 bolt up through tool and into nut.
11. Using two 17mm wrenches, tighten bolt into nut until rubber bushing pops out of rack.
12. Do these same steps to remove remaining bushing.

**With Tool Installed Simply Tighten Nut and Bolt to Extract Bushing**

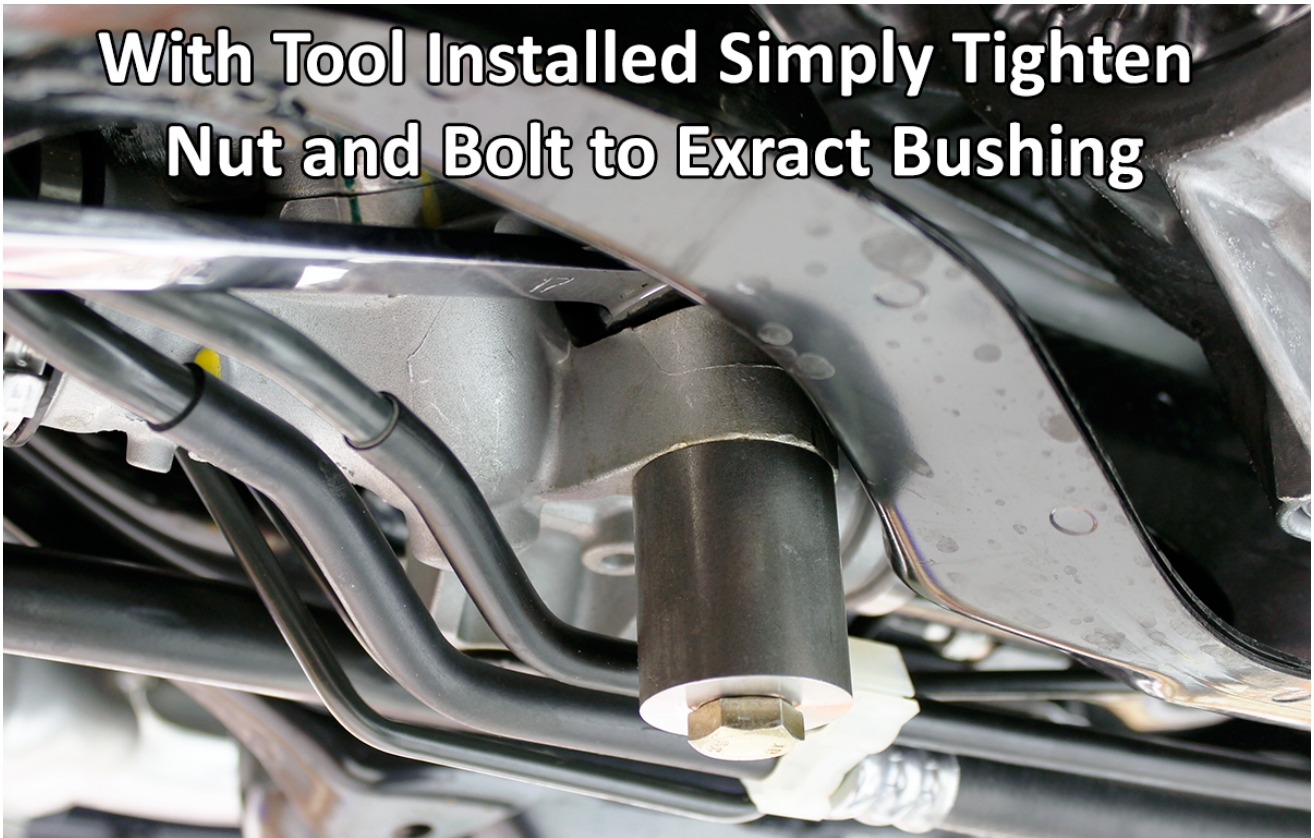

13. Apply a small amount of grease to outsides and insides of supplied urethane bushings.
14. Install bushings into upper and lower half of steering rack, making sure to press them in until the flanges bottom out.

15. Slide sleeves into bushings.



16. Slowly push steering rack back into engine cross member, making sure to align splines on the steering rack and universal joint. It helps to have a two people do this setup or a jack to help lift the rack up, while the splines are aligned.
17. Once rack is pushed all the way up to the chassis, install 12mm bolt into universal joint. **Note: If bolt doesn't thread in initially, some wiggling and pulling of universal joint may be necessary.**
18. Reinstall (2) 14mm bolts securing right side of steering rack to chassis and tighten bolts to 60 ft-lbs.
19. Install bracket and (4) 14mm bolts securing left side of steering rack to chassis and tighten bolts to 60 ft-lbs.
20. Reinstall jack plate and (8) or (10) 14mm bolts and tighten to 60ft-lbs.
21. Reinstall splash guard.
22. Take car for test drive and listen for any strange noise or clunking while steering. If any noises are found, recheck all hardware for being tight.

**FOR QUESTIONS & COMMENTS PLEASE CONTACT**

**[TECH@PERRINPERFORMANCE.COM](mailto:TECH@PERRINPERFORMANCE.COM)**

**503-693-1702**

**Live Chat with us on our website**