

Product Name: **Gen V IWG (BorgWarner EFR)**  
 Product Description: Gen V IWG  
 Product Number: TS-0620-1XXX  
 Document Version: V1.00 Rev A



**IMPORTANT NOTES ON YOUR INTERNAL WASTEGATE ACTUATOR**

- Turbosmart accepts no responsibility whatsoever for incorrect installation of this product which is potentially hazardous and can cause serious engine damage or personal injury.
- Consult your local specialist before setting your desired boost pressure, setting boost beyond your engines capability may result in engine damage.
- Use only high-quality fittings ensuring maximum sealing reliability. Optional Turbosmart fitting kit available.

**RECOMMENDATIONS**

- **Allow for adequate cool airflow around the diaphragm housing**
- **DO NOT Mount the wastegate so that the top diaphragm housing is less than 100mm from a heat source**
- **Turbosmart recommends that your wastegate is fitted by an appropriately qualified technician.**
- **Turbosmart recommends that the engines Air/Fuel ratio is checked while setting the desired boost pressure, as any increase in boost pressure can cause the engine to run "LEAN", resulting in possible engine damage.**
- Turbosmart recommends that boost pressure is set using a dynamometer and not on public roads.
- Turbosmart recommends that a boost gauge be permanently fitted to the vehicle.

**KIT CONTENTS**

Please check that the following items have been provided in your Gen V Wastegate kit.

Part	Description	Use
1	Turbosmart Gen V IWG	Main unit
2	Rod Kit	3x rods for fitment to BorgWarner EFR series turbos
3	Spring kit	3x springs: 2x inner, 1x middle, 1x outer (1x spring pre-installed)
4	Fitting kit	2x 1/8" NPT nipple, 4x 1/8" NPT blanking plugs (1x pre-installed)
5	Turbosmart Sticker	Turbosmart sticker
6	Turbosmart Position Sensor	Turbosmart HE Sensor (Sensor Cap Model Only)
7	IWG Actuator Collar Tool	Remove actuator collar to change spring

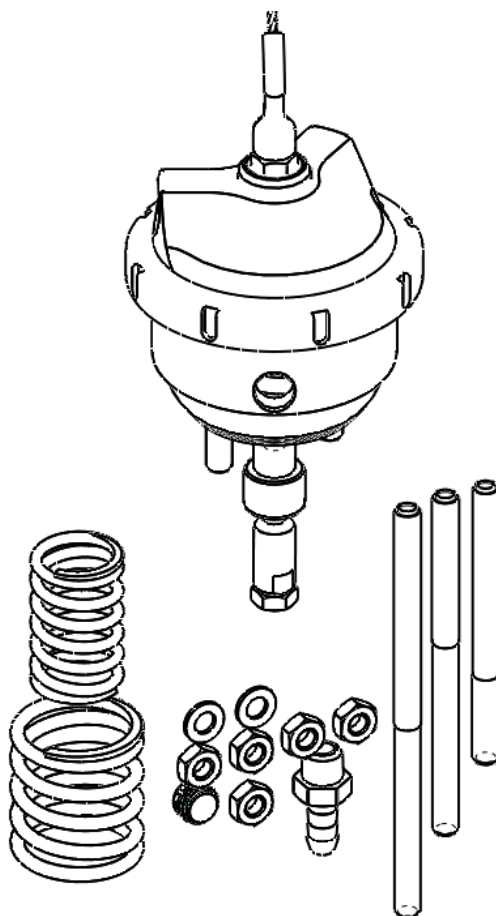

Figure 1 - Kit Contents

CONTENTS

KIT CONTENTS ..... 1

**TOOLS REQUIRED** ..... 2

**SUGGESTED SEALANTS** ..... 2

**GEN V WASTEGATE OVERVIEW**..... 3

**FITTING YOUR GEN V WASTEGATE**..... 4

**Applying Actuator Preload / Ensuring Wastegate Flap is Closed** ..... 5

**HOW TO CHANGE YOUR GEN V WASTEGATE SPRING** ..... 6

**ACHIEVING YOUR TARGET BOOST PRESSURE** ..... 7

**HOW TO USE A SENSOR CAP ON YOUR GEN V WASTEGATE** ..... 8

**TROUBLESHOOTING** ..... 8

**TOOLS REQUIRED**

- 10mm open end spanner
- Square drive ratchet wrench
- Torque wrench (3/8" drive)
- Non-marking spanners to tighten fittings
- 3/16" hex key
- Turbosmart IWG collar tool

**SUGGESTED SEALANTS**

- Loctite 243 Thread locker
- Loctite 567 Thread Sealant

# GEN V WASTEGATE OVERVIEW

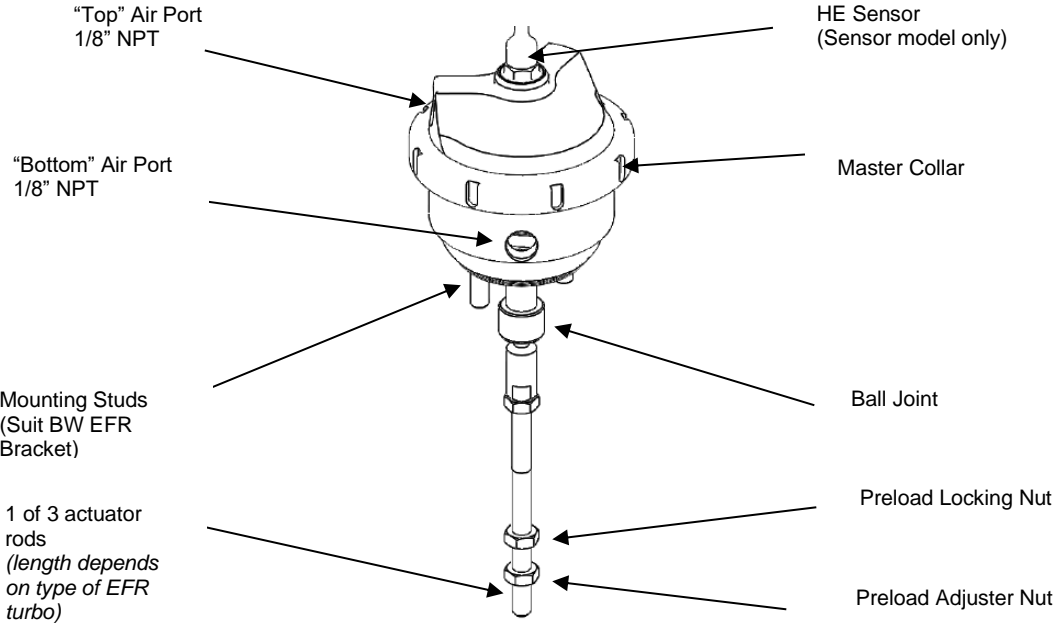

Figure 2 – Gen V Wastegate Overview

## FITTING YOUR GEN V WASTEGATE

### 1 Mounting your New Turbosmart Gen V IWG Wastegate

Slide the actuator head through the BorgWarner mounting bracket, be sure the balljoint assembly has been removed from the actuator canister otherwise the unit cannot be assembled onto the bracket. Once mounted on the bracket, secure nuts to hold actuator in place, be sure at this point to determine the orientation of the actuator as it can be flipped 180° on the actuator bracket to allow for fitting clearance, or aligning the actuator to your liking without need to disassemble the actuator.

**CAUTION!**  
Ensure nuts are tightened

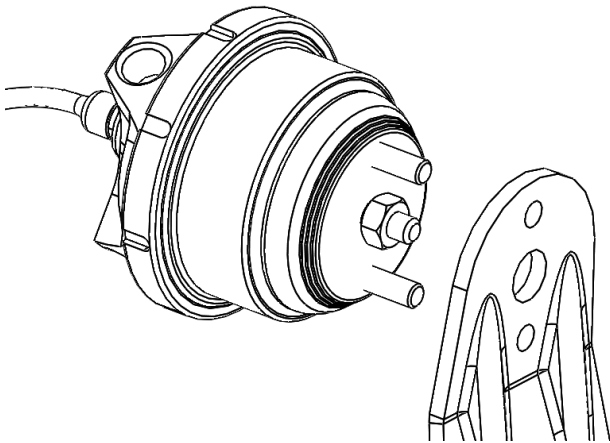

Figure 3 – Install Actuator through bracket

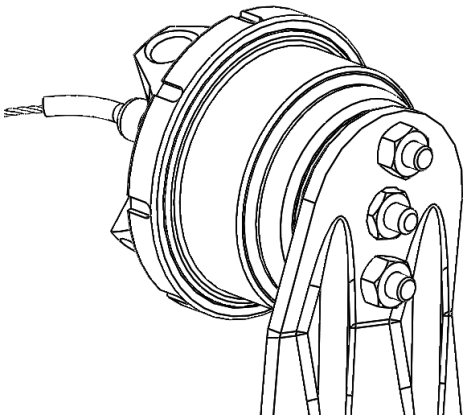
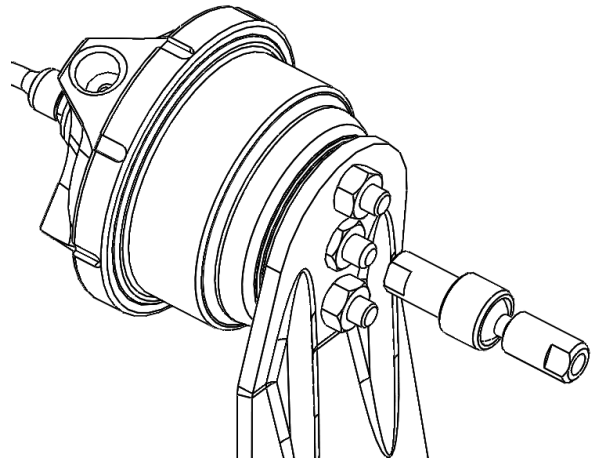

Figure 4 – Actuator secured onto bracket

### 2 Install the ball joint

Once the actuator has been mounted to the bracket, install the ball joint onto the main shaft out the actuator, orientation of the ball joint is not important. Use the flats machined into the ball joint to hold the ball joint in place as you tighten the nut on the main shaft to prevent unnecessary movement of the ball joint during operation.



### 3 Install Rod of Choice

Depending on the type of BorgWarner EFR turbocharger, they are available in different frame sizes, such as B1 and B2, and some are available in twin or single scroll configuration. As a result, we have provided all 3 rods that may be required for your turbocharger configuration. Simply select the rod length that allows for enough rod stick-out on the turbocharger actuator flap once installed. Generally, there is roughly ~5-10mm worth of stick-out on the wastegate clevis mount.

Select rod that will provide enough stick out on wastegate through hole mount in order to correctly tighten nuts either side of wastegate actuator flap mount.

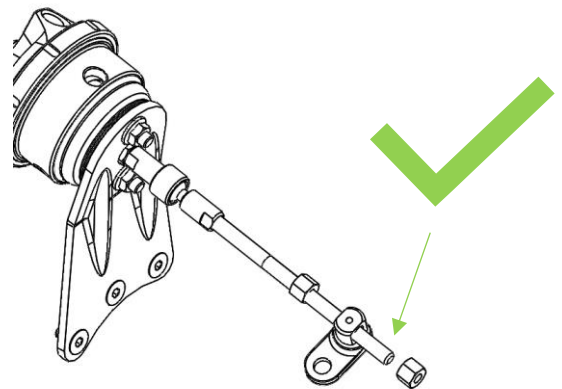
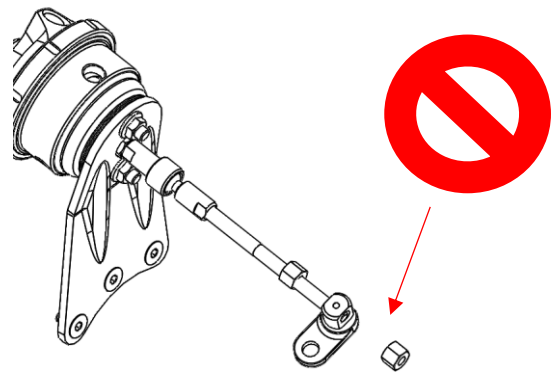

Once correct rod has been confirmed, install 1x nut onto each end of the rod, install rod through the wastegate actuator flap arm first, then slide up and screw into the ball joint until bottoms out, then tighten with backup nut firmly.

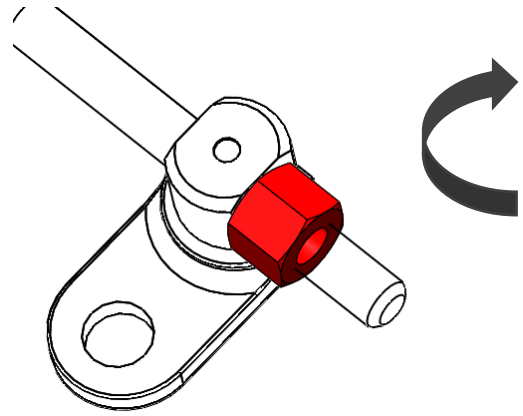
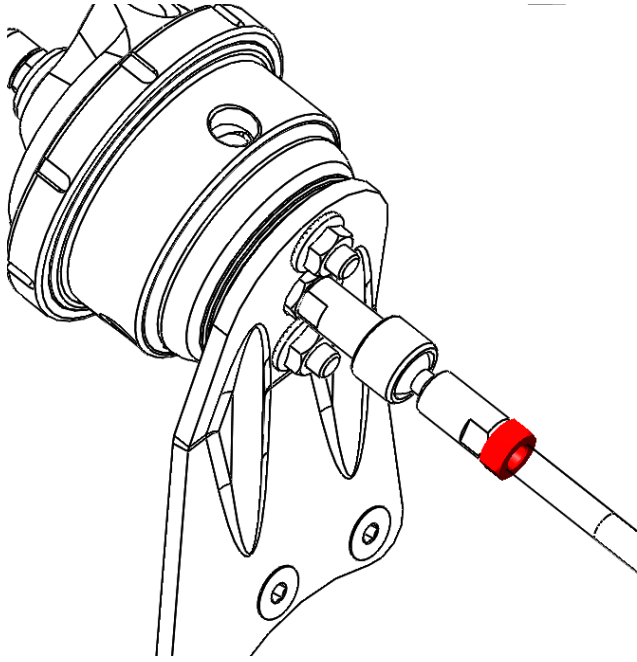

To apply 1mm/0.039" preload, simply turn the adjuster nut 1 full turn in the clockwise direction.

To lock the actuator in this position, turn the locking nut by hand until finger tight, then proceed to tighten nut firmly to secure actuator in place. (6.5Nm / 4.8 ftlb)

If a regulated air source is available on-hand, apply the air pressure of the spring installed to the actuator (5, 7 or 14psi) and observe the rod, the rod should begin to move slowly and freely over the range of travel as air pressure increases. If the rod does not move at all with increasing air pressure, proceed to troubleshooting.

#### **4** Applying Actuator Preload / Ensuring Wastegate Flap is Closed

**CAUTION!**  
This step is important

In order to ensure the actuator does not suffer any stiction/temperature creep issues or the wastegate flap does not stay slightly open, it is important to apply a small amount (1mm/0.039") of preload to the wastegate actuator.

To correctly preload the wastegate, ensure wastegate flap is in the full closed position by holding the actuator flap as far closed as possible, wind the adjuster nut onto the back face of the actuator flap as shown below (in red) until hand tight

#### **5** Start Engine and Check for Leaks

Congratulations, your Gen V wastegate is installed and ready for use. Double check all fittings, lines and mountings then proceed to start engine and check for leaks.

---

## HOW TO CHANGE YOUR GEN V WASTEGATE SPRING

The Gen V wastegate has a variety of springs to suit different boost levels. Turbosmart provides the Gen V wastegate pre-installed with a 14psi spring. With your wastegate 3 springs will be provided, 5psi inner, 7psi middle and 14psi outer. Different spring combinations may be required to suit different boost requirements and tuning.

### 1 Remove Wastegate From Turbocharger

Remove boost pressure source hose from the wastegate  
Remove preload from wastegate by undoing preload nuts  
Remove balljoint locking nut  
Remove rod from actuator and turbo assembly  
Remove ball joint assembly  
Remove wastegate actuator from bracket

#### CAUTION!

Allow engine to cool down before removing your Gen V wastegate

### 2 Remove Top Cap

Prior to removing the Gen V wastegate cap, remove all fittings from the ports. Press down with light to medium load on the cap in a press or vice. Unscrew locking collar with the large end of the provided collar tool in an anti-clockwise direction until completely disengaged and slowly remove tension from the press or vice allowing the spring to expand, finally remove cap when the spring has stopped expanding.

#### CAUTION!

Use soft jaws to prevent cosmetic damage

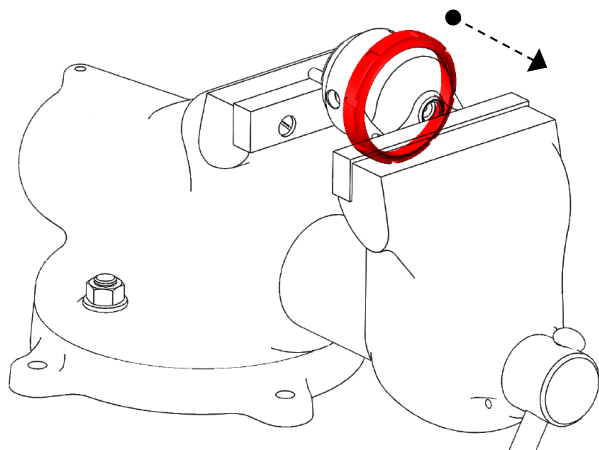

### 2 Remove Top Cap (cont.)

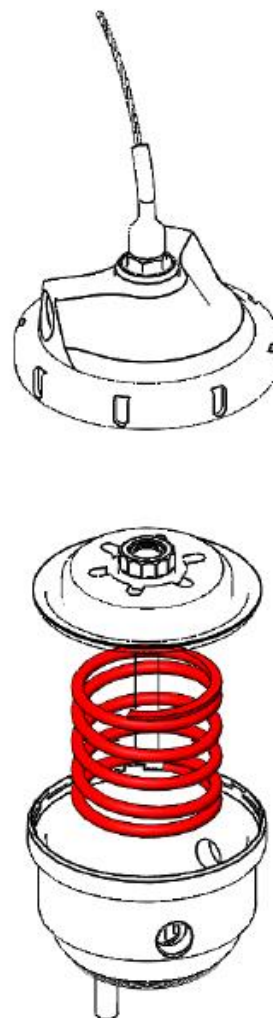

Configure wastegate with preferred spring combination of inner, middle and outer springs

### 3 Familiarise Yourself with Cap and Body Notches

Locate cap and body notches and grooves which dictate the alignment of the cap. These notches are used to locate the cap onto the body and must be aligned prior to compression of the cap onto the body

#### CAUTION!

Ensure notches are aligned and seated home correctly prior to exerting force to tighten collar, permanent damage will occur if these are not aligned correctly.

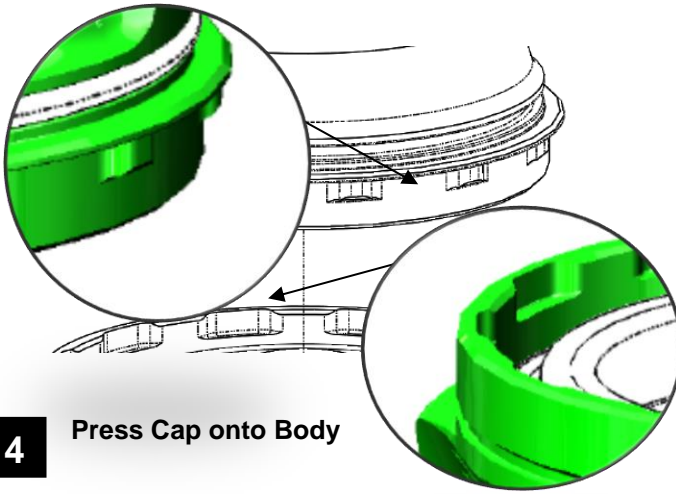

**4 Press Cap onto Body**

Using a press or vice, compress the cap onto the body ensuring the notches are remaining aligned. Once the cap has seated home onto the body, screw the collar down by hand in a clockwise direction. While still in the press or vice, Tighten the collar further with the collar tool until the collar will not turn.

**CAUTION!**  
 Maintain downward pressure on cap while tightening collar or non-repairable thread damage will occur.

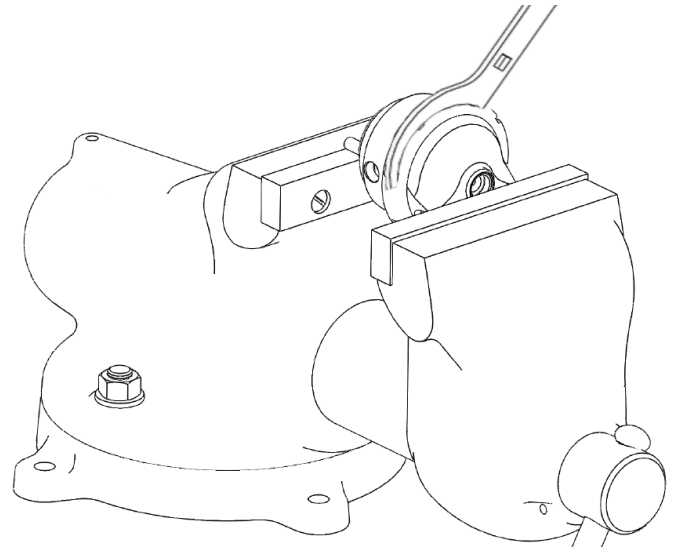

Reinstall fittings to the cap of the wastegate using fresh Loctite 567 thread sealant.

**5 Reinstall Gen V Wastegate**

- Install wastegate actuator assembly to bracket
- Install balljoint assembly
- Install balljoint lock nut
- Install rod to balljoint and turbocharger
- Apply wastegate preload
- Lock adjuster nuts
- Connect wastegate signal lines and check for leaks

If an adjustable air source is available, connect to signal ports and check for smooth free operation of wastegate, if wastegate does not move with increasing air pressure, proceed to troubleshooting.

aid in the identification of these springs they are supplied colour coded. If this colour coding is not clear please use the dimensions in the following table to identify the wastegate spring. Please see the following detailed instructions on setting your Gen V Wastegate's spring pressure. The springs chosen should be rated to the lowest boost level desired.

**ACHIEVING YOUR TARGET BOOST PRESSURE**

There are various factors involved in achieving your target boost pressure including.

- The size of the spring fitted in your wastegate i.e. the boost pressure achieved by the wastegate spring only.
- The desired level of boost pressure and the difference between this and your wastegate spring pressure.
- The size of your turbocharger and wastegate and the resulting exhaust manifold backpressure in your system.

Turbosmart recommends the ideal setup for achieving your target boost pressure is to use the Gen V Wastegate in conjunction with a Turbosmart e-Boost controller.

**IMPORTANT NOTES ON SETTING THE WASTEGATE SPRING PRESSURE**

A stiffer spring should only be used when necessary. The Gen V Wastegate allows for different combinations of spring pressures. All springs that are adaptable with the Gen V Wastegate are shown in the table below. The tuner can use combinations of up to 3 springs to achieve the following base boost pressures. To

Location	Inner	Middle	Outer
Pressure	5psi	7psi	14psi
5psi	•		
7psi		•	
12psi	•	•	
14psi			•
19psi	•		•
21psi		•	•
26psi	•	•	•

Table 1: Spring Chart

## HOW TO USE A SENSOR CAP ON YOUR GEN V WASTEGATE

### 7 Wiring

Your new Turbosmart sensor cap comes with sensor pre-installed into the cap with unterminated wires for you to fit the connector of your choice.

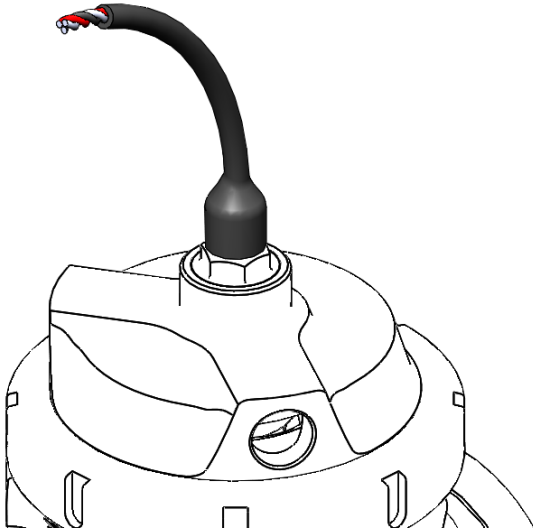

Wire	Note	Rating
Red	Sensor Supply ( $V_{sup}$ )	4.5-5.5 $V_{dc}$
Black	Sensor Ground ( $V_0$ )	0V
White	Sensor Output ( $V_{out}$ )	0- $V_{supply}$

Connect the wires to your data logger accordingly. Use a high-quality connection to reduce noise and calibration fluctuation.

Ensure that the wiring is properly shielded from external heat sources.

### CAUTION!

To ensure longevity from the sensor, ensure adequate airflow is supplied directly to the sensor to avoid overheating or sensor failure.

Turbosmart HE sensor has an operation temperature window of -40°C up to 170°C (340°F) junction temperature, for temperatures outside of this window the  $V_{OUT}$  will revert to less than 2.5V

Temperature exposure above 260°C (500°F) can cause permanent damage to the sensor.

### 8 Calibration\*

Rod Travel (mm)	$V_{OUT}$
0	0.439
2	1.21
4	1.58
6	1.84
8	2
10	2.13
12	2.21
14	2.27
16	2.32
18	2.36

**NOTE!** For best results, each wastegate should be calibrated to your setup.

## TROUBLESHOOTING

- Wastegate not actuating - Confirm signal hose is plumbed to a pressure only source, confirm preload during installation
- Poor wastegate actuation - Ensure signal hose is not shared and is sourced as close to the compressor as possible, check seal on fittings
- Poor wastegate actuation – Confirm no obstructions in actuator rod path
- Boost creeping at high rpm - Wastegate flow path is poor, wastegate is too small for the application, ensure balljoint is not seized
- Failing the above, submit a technical request to [tech@turbosmart.com.au](mailto:tech@turbosmart.com.au) with information of your engine configuration and photos of installation