

# Ecovector® II Smart Low Level



Ecovector II Low Level fan convectors provide warmth from a low level upwards and are more energy efficient and effective than radiators



## Features

- The Ecovector II can heat up a room more quickly than radiators, thereby reducing the amount of time your boiler or heat pump is running - making it extremely efficient and cost effective
- Compatible with most types of wet central heating systems, functioning equally efficiently with conventional boilers, biomass technology or ground or air source heat pumps
- Ideal for new and existing developments, due to ease of installation, the Ecovector is available in a range of models to suit varying room sizes and heat output requirements

## Applications

Education, healthcare, places of worship, leisure and sport, office, hospitality, retail, showroom, industrial and residential.

## Motor

AC only

## Finish

Front casing: zinc-coated steel.  
Polyester powder-coated RAL 9016.

## Installation

This heating appliance is intended for mounting on a wall at low level via the chassis mounting holes. The minimum recommended installation height is 100mm from the floor. There is no clearance required on either side of the heater.

Ecovector II is designed for use on standard two-pipe pumped central heating systems where the system hot water is generated from either a boiler or renewable sources.

## Commissioning

Check water is hot enough to activate the low temperature cut-out thermostat when in heating mode. Check functionality of thermostat and link to Hub if required.

## Control

Built-in smart control with manual/auto fan speed, time and temperature control.

Capable of being used with App when a Hub is used.

## Specification

To specify state:

Low level hydronic fan convector in white.

As Smith's Ecovector II Smart Low Level LL640/LL1030/LL1390.

# Ecovector® II Smart Low Level



Ecovector II Low Level fan convectors provide warmth from a low level upwards and are more energy efficient and effective than radiators

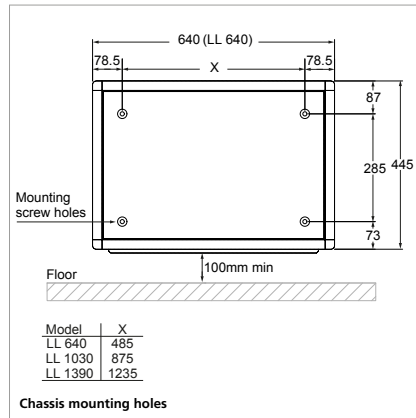
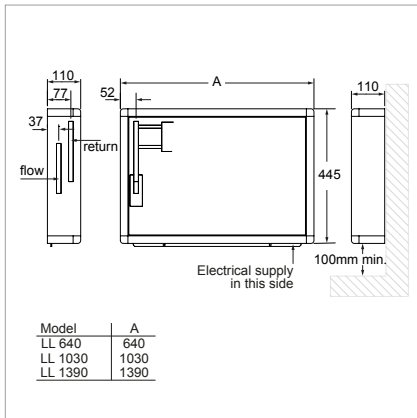

## Heat output

Model	Heat Output at 80°			Heat Output at 75°			Heat Output at 70°			Heat Output at 65°			Heat Output at 60°		
	Low (kW)	Normal (kW)	Boost (kW)	Low (kW)	Normal (kW)	Boost (kW)	Low (kW)	Normal (kW)	Boost (kW)	Low (kW)	Normal (kW)	Boost (kW)	Low (kW)	Normal (kW)	Boost (kW)
ECONVECTOR II SMART LL 640	1.2	1.6	2.0	1.1	1.4	1.7	1.0	1.3	1.6	0.9	1.1	1.3	0.8	1.0	1.2
ECONVECTOR II SMART LL 1030	2.0	2.6	3.2	1.9	2.4	2.9	1.6	2.2	2.8	1.5	1.9	2.3	1.3	1.7	2.1
ECONVECTOR II SMART LL 1390	2.8	3.5	4.2	2.6	3.2	3.8	2.3	2.9	3.5	2.0	2.6	3.2	1.9	2.4	2.9

Model	Heat Output at 55°			Heat Output at 50°			Heat Output at 45°			Heat Output at 40°		
	Low (kW)	Normal (kW)	Boost (kW)	Low (kW)	Normal (kW)	Boost (kW)	Low (kW)	Normal (kW)	Boost (kW)	Low (kW)	Normal (kW)	Boost (kW)
ECONVECTOR II SMART LL 640	0.7	0.8	0.9	0.6	0.7	0.8	0.5	0.6	0.7	0.4	0.5	0.6
ECONVECTOR II SMART LL 1030	1.2	1.6	1.9	1.0	1.3	1.6	0.9	1.1	1.3	0.7	0.8	0.9
ECONVECTOR II SMART LL 1390	1.9	2.1	2.3	1.3	1.8	2.2	1.2	1.5	1.8	1.0	1.2	1.4

Model	Flow & return connections	Mains cable	Transformer	Fused spur	Total Power Consumption			Water Capacity (Litres)	Sound Levels			Casting colour	Fan-only
					Low (Watts)	Normal (Watts)	Boost (Watts)		Low (dBA)	Medium (dBA)	High (dBA)		
ECONVECTOR II SMART LL 640	15mm	1.5m	n/a	3A	9	12	21	0.29	32	38	TBC	white	n/a
ECONVECTOR II SMART LL 1030	15mm	1.5m	n/a	3A	12	16	29	0.58	35	40	TBC	white	n/a
ECONVECTOR II SMART LL 1390	15mm	1.5m	n/a	3A	24	33	58	0.83	37	42	TBC	white	n/a

Heat outputs tested in accordance with BS4856 using entering water temperature and 340 l/h (75gph) flow rate. Sound levels measured at 1.5m.

## Ordering guide

Model	Packed Wt (kg)	Product Codes
ECONVECTOR II SMART LL 640	14	HPEV50022
ECONVECTOR II SMART LL 1030	19	HPEV50023
ECONVECTOR II SMART LL 1390	26	HPEV50024

As part our commitment to continuous improvement Smith's Environmental Products may change the specifications of its products without prior notification or public announcement. All descriptions, illustrations, drawings and specifications in this publication present only general particulars and shall not form part of any contract. All dimensions are in mm unless otherwise stated. Please visit our website for the most up to date information.

Issue 001 | July 2022