

Product Details

Dot self-test luminaire features our design protected, Halo effect bi-colour LED for easy fault detection. Ideal for office lighting, retail lighting and hospitality lighting, Dot features a bi-colour LED: green for 'charge healthy' and red for fault indication.

- Can be driven up to 700mA
- Up to 268 lumens Mymesh and EOS remote reporting systems



Product Specification

IP Rating (IP)	IP54
Ambient temperature (Ta)	50°
Charge power (W)	2
Battery	3.2V 3.8Ah LiFePO4

Electrical Specification

Voltage (V)	220-240
Frequency (Hz)	50-60
Electrical Protection	Class II

Lumen Performance

Product Code	Output	Colour	Wattage
DT LED1 6K W E3	156	760	3
DT LED2 6K W E3	224	760	3
DT LED3 6K W E3	268	760	3

Luminaire Options

Emergency	3hr	3hr Dali	Self-Test
Colour	White	Black	
Lens	Wide	Corridor	Flood
Battery	LiFePO4		

Accessories



Open Area Lens

Corridor Lens



Flood Lens

Dimensions

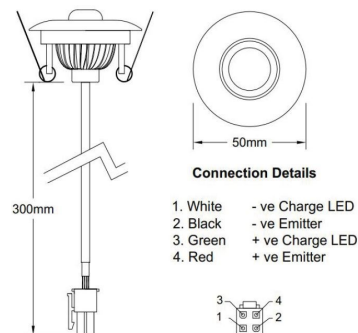

Diameter (mm) 50

Cut-out (mm) 43

Height (mm) 45

Weight (kg) 0.8