

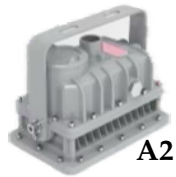

BPO LIGHTING
Hazardous Area Lighting

HLL A TUNABLE



Class 1 Division 2

Key Features

FEATURES: Tunable Wattage
Adjustable CCT

Compact Rugged Low-Bay/High-Bay Flood
High Lumen efficiency up to 175 lm/W
Impact Resistant

OPTIONS: 4 Body Sizes
8 Mounting Styles
T2, T3, T5, 30°, 40°, 60°, 90° or 120°
Lens: Clear or Frosted / Glass or PC
High Voltage
Emergency Back-Up

Compliance

UL 844 Hazardous Locations
Class I Division 2 Groups A, B, C, D
Class I, Zone 2, Group IIC
Class II Division 1 Groups E, F, G
Class II Division 2 Groups F, G
Class II, Zone 21, Group IIIC
Zone 2, 21,22
Class III
UL 1598 Suitable Locations
UL 1598A Marine Saltwater

IP66
IK08 (Without Wire Guard)
IK10 (With Wire Guard)
1000 Hours Salt Spray
ETL (ATM for Report 105342415DAL-001)
ABS
CB (Ref. Certif. No.: DE 2-038462-M1)
EX II 3G Ex ec IIC T6...T3 Gc
EX II 2D Ex tb IIIC T85°C...T103°C Db IP66
Ex ec IIC T6...T3 Gc
Ex tb IIIC T85°C...T100°C Dbn IP66
DLC qualification varies for product versions.

Applications

Oil and Gas

Petroleum production and refining
Petroleum loading, storage, transportation and retail
Confined spaces with vapor accumulation
LNG and LPG handling
Oil tankers and shipping vessels
Fuel system testing facilities

Power Plants

Coal-fired power plants, including coal handling and storage areas
Gas-fired power plants with fuel storage
Nuclear power facilities in hazardous auxiliary areas
Biomass or waste-to-energy plants with combustible dust risks

Industrial

Industrial storage facilities
Paper mills, sawmills and lumber yards
Loading dock platforms
Manufacturing plants for heavy industrial goods
Warehouses handling flammable materials

Waste Treatment

Wastewater treatment plants
Pumping stations
Solid waste processing and incineration facilities
Sewage treatment with methane gas risks
Hazardous waste recycling centers

Mining

Operations and service areas
Underground mining tunnels with gas accumulation

Chemical Industry

Chemical production, processing and storage facilities
Solvent handling and mixing areas
Chemical research labs with flammable substances

Ocean, Marine and Aerospace

Offshore platform operation facilities and structures
Marine and saltwater environments
Aerospace clean rooms and production areas
Ocean vessel operations
Shipyards and dry docks
Aircraft hangars with fuel vapors

Metal Treatment

Paint facilities
Steel and aluminum factories
Metal smelting, foundry and fabrication
Welding and cutting areas with gas risks

Military and Defense

Ammunition storage and handling
Fuel depots and refueling stations
Explosives manufacturing
Vehicle maintenance bays in hazardous zones

Food, Alcohol and Agriculture Industry

Flour and fine particle production and storage
Food and distilling production
Grain storage elevators and silos
Breweries and fermentation tanks
Feed mills with dust risks
Fertilizer production and storage

Pharmaceutical Industry

Drug manufacturing and solvent handling
Clean rooms with volatile compounds
Pill coating and drying areas
Research and development labs

Other high humidity, high dust, high temperature and vapor locations

Specifications

Wattage	20 W	25 W	30 W	35 W	40 W	50 W	60 W	70 W	20 W	40 W	60 W	80 W	100 W	120 W	150 W	60 W	80 W	100 W	120 W	150 W	180 W	200 W	240 W	150 W	180 W	200 W	250 W	300 W	350 W	400 W	500 W
Body	A2							A					A3					A4													

OPTICAL

Lumen Output	3300 lm	4125 lm	4950 lm	5775 lm	6600 lm	8250 lm	9900 lm	11550 lm	3300 lm	6600 lm	9900 lm	13200 lm	16500 lm	19800 lm	24750 lm	10500 lm	14000 lm	17500 lm	21000 lm	26250 lm	31500 lm	35000 lm	42000 lm	26250 lm	31500 lm	35000 lm	43750 lm	52500 lm	61250 lm	70000 lm	87500 lm	
Lumens Per Watt	165 lm/W															175 lm/W																
Color Temperature: CCT	SELECTABLE: Standard 5000K Options: 2000K/3000K/4000K/5000K/5700K/6000K/6500K/7500K																															
CRI (Color Rendering Index)	> 70																															
Beam Angle	Standard: 120° Options: 30°/40°/60°/90°/T2/T3/T5																															
Dimming	0-10V dimming																															

ENVIRONMENTAL

Ambient Operating Temperature	T4A: -40°C to +55°C (-40°F to +131°F)	T4A: -40°C to +50°C (-40°F to +122°F), T5: -40°C to +40°C (-40°F to +104°F)	300W/350W T5: -40°C to +55°C (-40°F to +131°F) 400W T4A: -40°C to +55°C (-40°F to +131°F) 500W T4A: -40°C to +50°C (-40°F to +122°F)
Temperature Code	T4A +55°C	T4A +50°C, T5 +40°C	T4A +50°C (500W) T4A +55°C (400W) T5 +55°C
Power Model (120-277VAC/347VAC)	FD-100T-054D	SS-150VA-56BHL	SS-200VA-56BHL SS-500VP (300W/350W) SS-600VP (400W/500W)

MECHANICAL

Housing Material	Die-cast aluminum
Lens Diffuser	Standard: Clear Flat Glass Options: Clear Flat Glass, Clear Flat PC, Frosted Flat Glass, Frosted Flat PC
Hardware	Stainless Steel
Fixture Color	Grey RAL7040 (Standard)
Mounting	Ceiling, Wall, Pole, Pendant
Cable Entry	Two 3/4" NPT thread on the side
LED Chip	2835
Warranty	5-Year Standard Warranty

ELECTRICAL

Lifespan	L70> 78,000 Operational Hours @ 55°C
Input Voltage	120-277VAC, 120-347VAC, 277-480VAC
Input Frequency	50/60Hz
Power Factor	> 0.95
LED Driver	Sosen/Fahold (120-270VAC/120-347): Meanwell (200-480VAC)

EMERGENCY

Emergency Time	1.5 Hour, 3 Hour
----------------	------------------

Ordering Logic

ORDER EXAMPLE: HLL A EX 200W A3 D 50 D120 T

(1) Product	(2) Product Category	(3) Rated Input Wattage	(4) Shape Series	(5) Dimming
HLL A	EX - Explosion Proof	150W: 150W/100W/80W [A] 200W: 200W/150W/120W [A3] Inquire About Additional Wattage Combinations: A2: 20W, 25W, 30W, 35W, 40W, 50W, 60W, 70W A: 20W, 40W, 60W, 80W, 100W, 120W, 150W A3: 60W, 80W, 100W, 120W, 150W, 180W, 200W, 240W A4: 150W, 180W, 200W, 250W, 300W, 350W, 400W, 500W	A2 A A3 A4	Blank - Non-Dimmable D - Dimmable (S)
(6) Kelvin	(7) Beam Angle	(8) Lens	(9) Tunable	(10) Backup Power Source
20 - 2000 K	D30 - 30°	CFG or Blank - Clear Flat Glass (S)	T - Tunable	Blank - Without Emergency Battery
30 - 3000 K	D40 - 40°	CFP - Clear Flat PC		EM - Emergency Battery
40 - 4000 K	D60 - 60°	FFG - Frosted Flat Glass		
50 - 5000 K (S)	D90 - 90°	FFP - Frosted Flat PC		
57 - 5700 K	D120 - 120° (S)			
60 - 6000 K	T2 - 60°			
65 - 6500 K	T3 - 90°			
75 - 7500 K	T5 - 120°			

Accessories



45° Bracket



Bracket



Lifting Hook



EX Junction Box



Wall Mounted Stanchion Arm



25° Stanchion Pole Mount



Threaded Pipe



Bent Threaded Pipe



Chain



90° Stanchion Junction Box



25° Stanchion Junction Box

Photometric

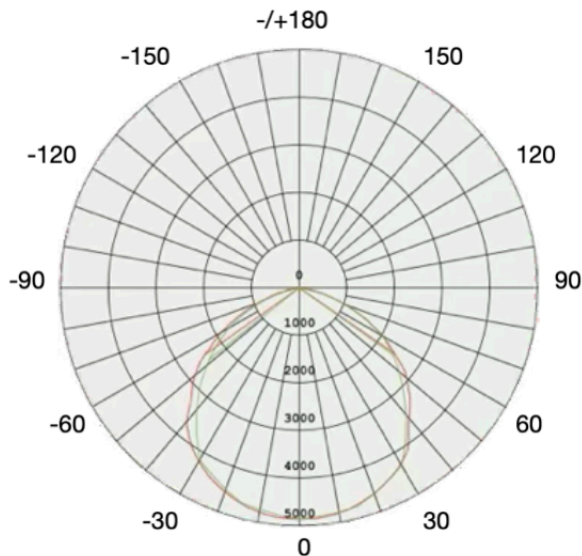

120 Degree

Average Beam Angle (50%): 107.8 Degree

UNIT: cd
 — V 0.0DEG PLAN, 109.9°
 — H 0.0DEG PLAN, 105.8°

Product Dimensions

A2

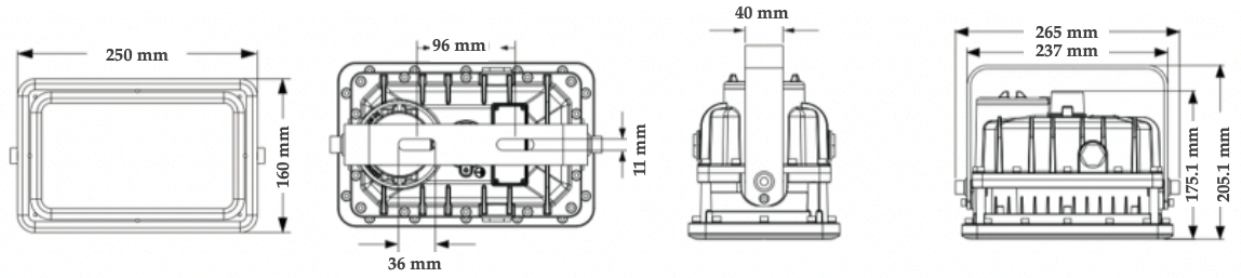

A

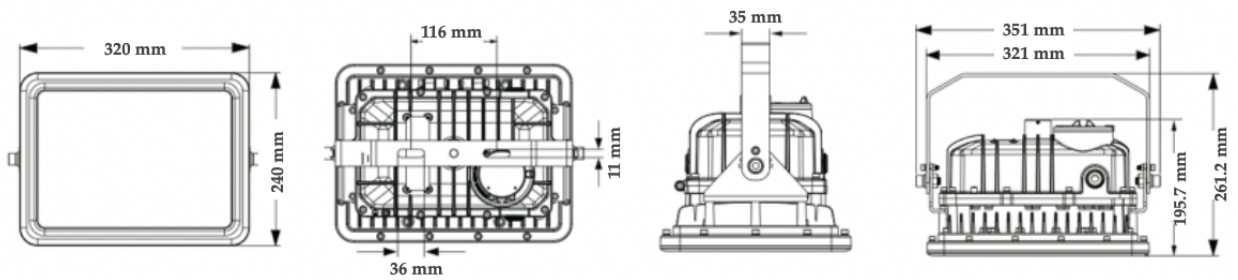

A3

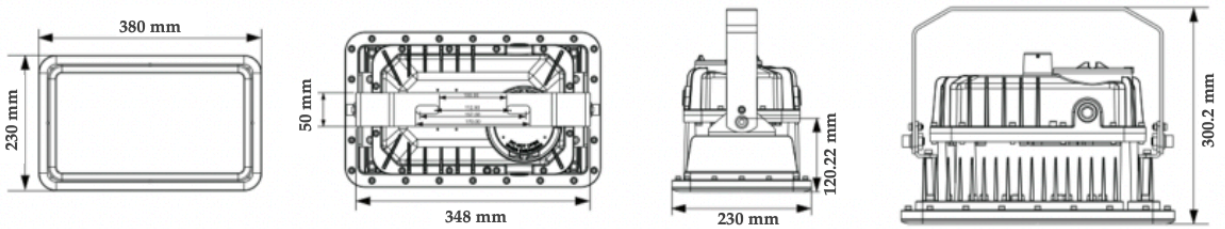

A4

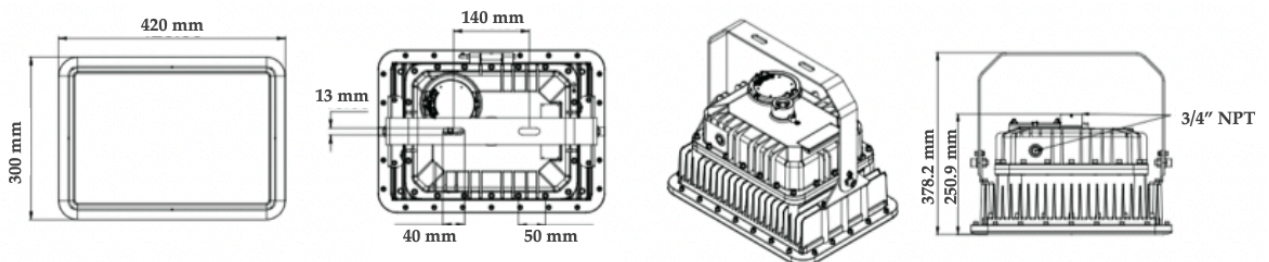

Packaging Information

	A2	A	A3	A4
Pieces	1	1	1	1
Fixture Dimensions	See Product Dimensions Drawing	See Product Dimensions Drawing	See Product Dimensions Drawing	See Product Dimensions Drawing
Package Dimensions	14.37 x 10.63 x 12.01 in (365 x 270 x 305 mm)	16.93 x 12.60 x 13.78 in (430 x 320 x 350 mm)	18.11 x 14.25 x 11.61 in (460 x 362 x 295 mm)	19.57 x 18.31 x 13.78 in (497 x 465 x 350 mm)
Net Fixture Weight	10.08 lb (8.2 kg)	9.15 lb (4.15 kg)	23.15 lb (10.5 kg)	33.29 lb (15.1 kg)
Gross Weight	19.84 lb (9 kg)	11.68 lb (5.30 kg)	25.35 lb (11.5 kg)	40.90 lb (18.55 kg)

Mounting Methods

Option 1: Ceiling Mount

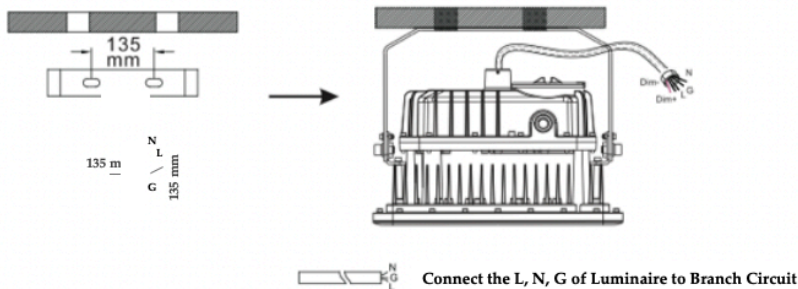

Accessory



Bracket

Option 2: Wall Mount

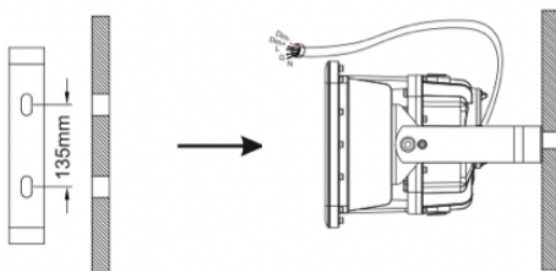

Accessory



Bracket

Option 3: Pendant Mount

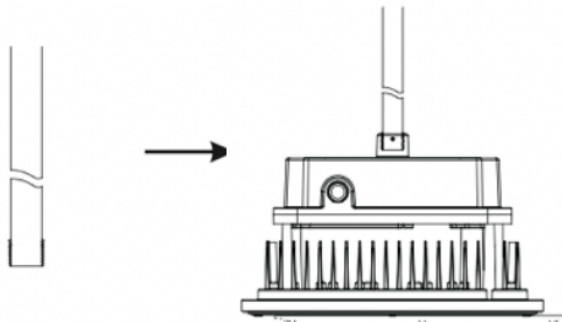

Accessory



EX Junction Box



Threaded Pipe

Option 4: 45° Pole Mount

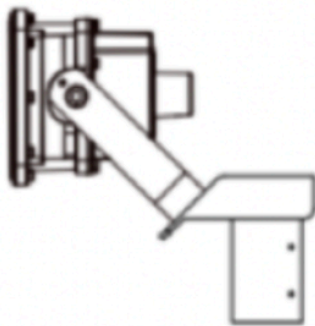

Accessory



45° Bracket

Option 5: Hook & Chain Mount

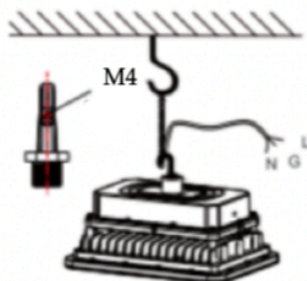

Accessory



Lifting Hook



Chain

Option 6: Wall Mount Wall Mounted Stanchion Arm 90°

Accessory

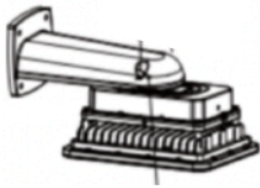

**Wall Mounted
Stanchion Arm**

Option 7: Stanchion Pole Mount

Accessory

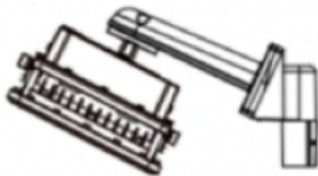

**25° Stanchion
Pole Mount**

**90° Stanchion
Pole Mount
(Not Shown)**

Option 8: Wall Stanchion Mount With Junction Box

Accessory

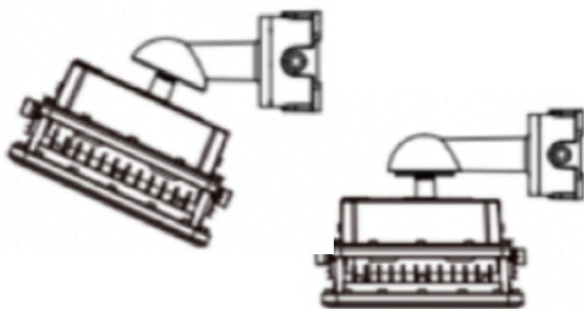

**90° Stanchion
Junction Box**



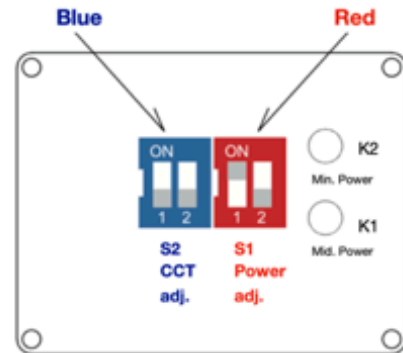
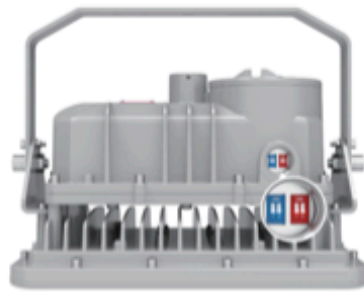

**25° Stanchion
Junction Box**



OPERATING INSTRUCTIONS



S1 DIP SWITCH - RED (S1 Power adj.)

The power adjustment dial switch can be set to three power levels, and the factory default setting can be defined according to order requirements.

-  First gear (Max. power), 100% full power.
Operation instructions: Dial 1 and 2 are both in the OFF position;
Example: 100W
-  Second gear (Mid. power), 70%-80% power, can be set according to the required power.
Operation instructions: Dial 1 is in the ON position, Dial 2 is in the OFF position;
Example: 80W
-  Third gear (Min. power), 50%-60% power, can be set according to the required power.
Operation instructions: Dial 1 is in the OFF position, Dial 2 is in the ON position;
Example: 60W

S2 DIP SWITCH - BLUE (S2 CCT adj.)

The color temperature dial switch can be set to three levels of color temperature, and the factory default setting can be defined according to order requirements.

-  First gear, the cold white temperature gear, for example, 6000K.
Operation instructions: Dial 1 and 2 are both in the OFF position;
Example: 6000K
-  Second gear, the neutral temperature gear, for example, 5000K.
Operation instructions: Dial 1 is in the ON position, and Dial 2 is in the OFF position;
Example: 5000K
-  Third gear, the warm white temperature gear, for example, 4000K.
Operation instructions: Dial 1 and 2 are both in the ON position;
Example: 4000K

(1) Power Adjuster:

Connect to the 0/1-10V dimming port of the LED driver.

(2) CCT Adjuster:

Connect the output voltage of the LED driver:

DC20 - 60V LED driver maximum no - load output voltage: 68V max

(3) The three - gear power setting principle is as follows:

The first gear is 100%, the second gear is 70 - 80%, and the third gear is 50 - 60%.
The minimum setting cannot be lower than 50%.