

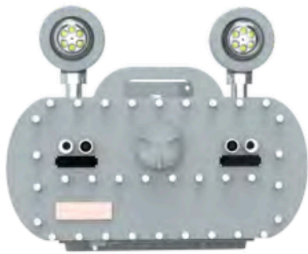

BPO LIGHTING
Hazardous Area Lighting

ES 03



ES03 A1
Emergency Light



ES03 C1
Emergency Light



ES03 A2
Emergency Light
+Exit Sign



ES03 A3
Exit Sign



Class 1 Division 1

Key Features

FEATURES:

- Emergency Light (Rugged)
- Push to test
- ES03A1/A2/A3 use hinge and screws
- ES03C1 is constructed with screws to tighten the cover plate
- Cost Effective
- 3 Hr Emergency Back-Up

OPTIONS:

- A1/C1/A2** Red, Green or White
- A2/A3** Red or Green Sign
11 Sign Markings

Compliance

UL 844 Hazardous Locations
Class I Division 1 Groups C, D
Class I Division 2 Groups A, B, C, D
Class I Zone 1 IIB
Class II Division 1 Groups E, F, G
Class II Division 2 Groups F, G
Class III

UL 1598 Suitable for Wet Locations
UL 1598A Marine Saltwater
UL 924 Emergency Lighting
IP66 / Wet Locations
IK08 (Glass)
IK10 (Enclosure)
ETL
NEMA 4X

Applications

Oil and Gas

Petroleum production and refining
Petroleum loading, storage, transportation and retail
Confined spaces with vapor accumulation
LNG and LPG handling
Oil tankers and shipping vessels
Fuel system testing facilities

Power Plants

Coal-fired power plants, including coal handling and storage areas
Gas-fired power plants with fuel storage
Nuclear power facilities in hazardous auxiliary areas
Biomass or waste-to-energy plants with combustible dust risks

Industrial

Industrial storage facilities
Paper mills, sawmills and lumber yards
Loading dock platforms
Manufacturing plants for heavy industrial goods
Warehouses handling flammable materials

Waste Treatment

Wastewater treatment plants
Pumping stations
Solid waste processing and incineration facilities
Sewage treatment with methane gas risks
Hazardous waste recycling centers

Mining

Operations and service areas
Underground mining tunnels with gas accumulation

Chemical Industry

Chemical production, processing and storage facilities
Solvent handling and mixing areas
Chemical research labs with flammable substances

Ocean, Marine and Aerospace

Offshore platform operation facilities and structures
Marine and saltwater environments
Aerospace clean rooms and production areas
Ocean vessel operations
Shipyards and dry docks
Aircraft hangars with fuel vapors

Metal Treatment

Paint facilities
Steel and aluminum factories
Metal smelting, foundry and fabrication
Welding and cutting areas with gas risks

Military and Defense

Ammunition storage and handling
Fuel depots and refueling stations
Explosives manufacturing
Vehicle maintenance bays in hazardous zones

Food, Alcohol and Agriculture Industry

Flour and fine particle production and storage
Food and distilling production
Grain storage elevators and silos
Breweries and fermentation tanks
Feed mills with dust risks
Fertilizer production and storage

Pharmaceutical Industry

Drug manufacturing and solvent handling
Clean rooms with volatile compounds
Pill coating and drying areas
Research and development labs

Other high humidity, high dust, high temperature and vapor locations

Specifications

	ES O3A1			ES O3C1			ES O3A2			ES O3A3	
Wattage	10W	15W	17W	10W	11W	12W	10W	15W	17W	3W	5W
Body	A1 Emergency Light			C1 Emergency Light			A2 Emergency Light +Exit Sign			A3 Exit Sign	

OPTICAL

Lumen Output	1100 lm	1650 lm	1870 lm	1100 lm	1210 lm	1320 lm	1100 lm	1650 lm	1870 lm		
Lumens Per Watt	110 lm/w										
Color Temperature: CCT	5000K (standard), 3000-6500K optional										
Beam Angle	120° Standard, 90°option										
LED Lamp	White, Red or Green										
Color of Exit Sign							Red or Green				

ENVIRONMENTAL

Ambient Operating Temperature	-0°C to +45°C (32°F to +113°F); Discharging -20°C to +60°C (-4°F to +140°F)
-------------------------------	---

MECHANICAL

Housing Material	Die-cast Aluminum, Hinge & Screws	Die-cast Aluminum. Screws to tighten plate	Die-cast Aluminum, Hinge & Screws
Lens Diffuser	Tempered Glass		
Sign Panel Material			Tempered Glass
Lamp Adjustable Angle	0°-180°		
Spot Light	Can Be adjusted in horizontal and vertical directions		
Hardware	Stainless Steel		
Mounting	Wall		
Cable Entry	3/4" NPT		
Warranty	5 Year Standard Warranty		











ELECTRICAL

Lifespan	L70> 50,000 Operational Hours @ 40°C		
Input Voltage	100-277V		100-277VAC, 12-48VDC
Input Frequency	50/60Hz		

EMERGENCY				
Emergency Time	3 Hour	3 Hour	3 Hour	3 Hour
Independent Battery Backup	Spot Light	Spot Light	Emergency Sign & Spot Light	Emergency Sign
Power of Two Spot Lights @120V, 50-60Hz	7W @ Fully Charged; 10W @ During Charge			
Power of Two Spot Lights @277V, 50-60Hz	9W @ Fully Charged; 12W @ During Charge			
Power of Exit Sign			3W to 5W	
Lamp Adjustable Angle	0°-180°			
Glass EXIT Sign Plate	Tempered Glass		Tempered Glass	
EXIT Sign Color			Red or Green	
Spot Light	Can be adjusted in horizontal and vertical directions			

Ordering Logic

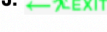
ORDER EXAMPLE: ESO3 EX 15W A1 D 5K
 ESO3 EX 12W C1 D 5K
 ESO3 EX 15W A2 D 5K R A
 ESO3 EX 5W A3 D 5K R A

(1) Product	(2) Product Category	(3) Wattage	(4) Product Type	(5) Dimming	(6) Kelvin	(7) Sign Color	(8) Sign Type
ESO3	EX - Explosion Proof Product	A1: 10W	A1 - Emergency Light	D - Dimmable	3K - 3000 K	A2/A3	A2/A3
		15W	C1 - Emergency Light	N - Non-Dimmable	4K - 4000 K	R - Red	A:  B: 
		17W	A2 - Emergency Light + Exit Sign		5K - 5000 K (S)	G - Green	C:  D: 
		C1: 10W	A3 - Exit Sign		6.5K - 6500 K		E:  F: 
		11W			A1/C1/A2: R - Red		G:  H: 
		12W			G - Green		I:  J: 
		A2: 10W					K: 
		15W					
		17W					
		A3: 3W					
		5W					

(S) Standard

Product Dimensions

ESO3 A1

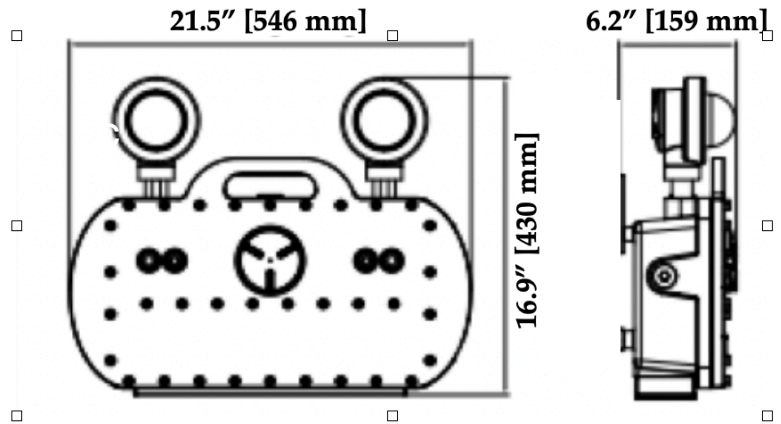
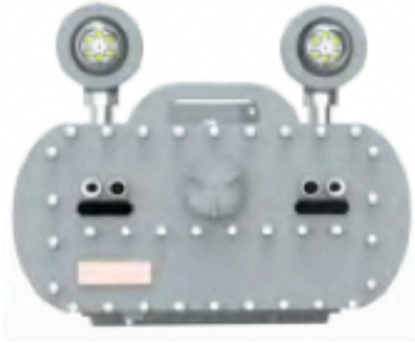

ESO3 C1

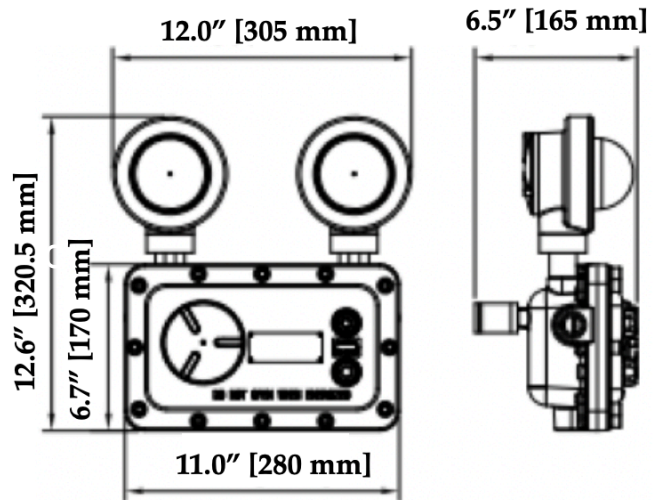

ESO3 A2

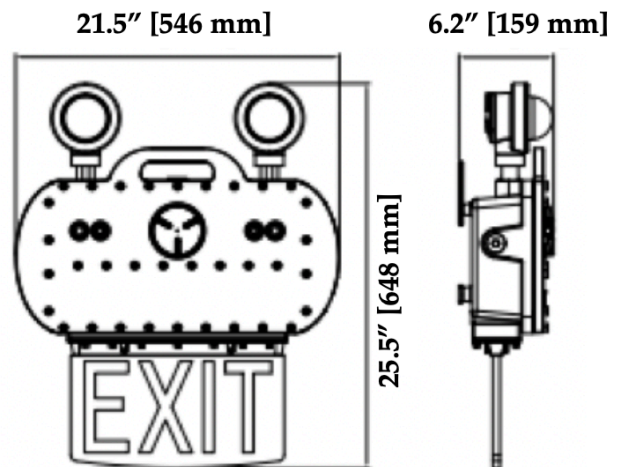

ESO3 A3

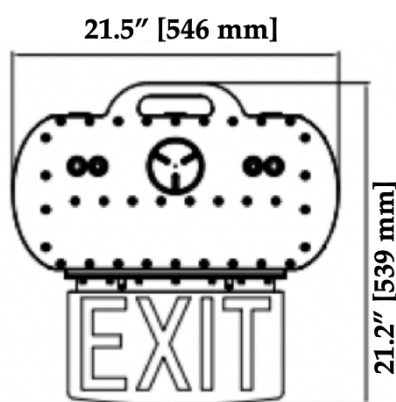

6.2" [159 mm]

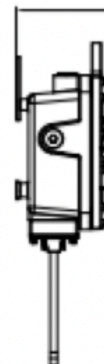

Packaging Information

	ES 03A1	ES 03C1	ES 03A2	ES 03A3
	A1 Emergency Light	C1 Emergency Light	A2 Emergency Light +Exit Sign	A3 Exit Sign
Pieces	1			
Fixture Dimensions	See Product Dimensions Drawing			
Package Dimensions	22.28 x 20.67 x 11.45 IN (566 x 525 x 290 MM)	17.32 x 17.72 x 12.20 IN (440 x 450 x 310 MM)	29.92 x 25.59 x 14.17 IN (760 x 650 x 360 MM)	29.13 x 22.28 x 11.45 IN (740 x 566 x 290 MM)
Net Fixture Weight	44.09 lb (20.0 kg)	17.64 lb (8.0 kg)	55.12 lb (25.0 kg)	55.12 lb (25.0 kg)
Gross Weight	48.50 lb (22.0 kg)	21.61 lb (9.8 kg)	66.14 lb (30.0 kg)	59.52 lb (27.0 kg)

Wiring Diagram

ESO3 A1 / ES03 C1 (Emergency Light)

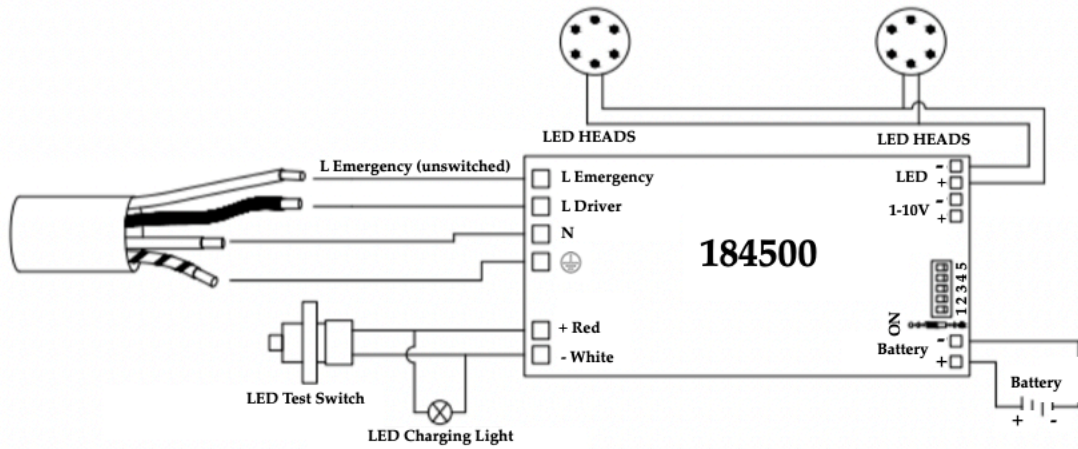

ESO3 A2 (Emergency Light + Exit Sign)

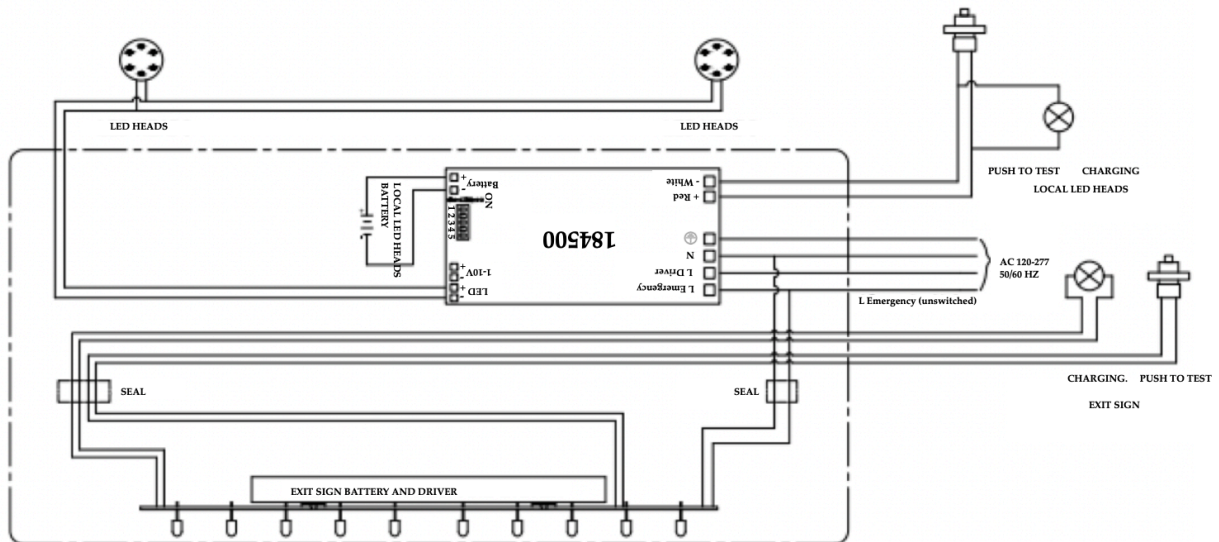

ESO3 A1 Wall Mounting

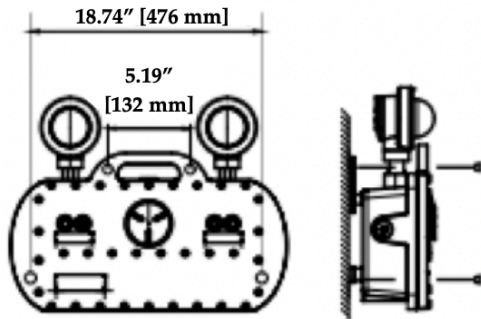

1. Drill four holes as fig. 1
The distance as per
18.74" [476 mm] and 5.19" [132 mm]

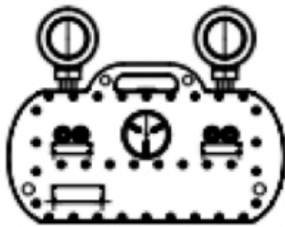

2. Fix with four 5/16" expansion screws

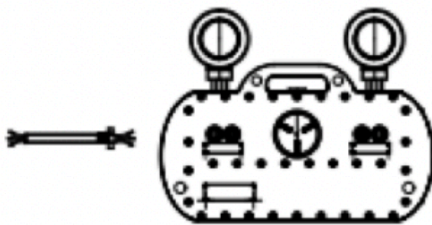

3. Install pipe to 3/4" NPT entry
and fix 0.63" [16mm] chemical filler

Then connect the AC cable:

Black joins to L

White joins to N

Green joined to grounding

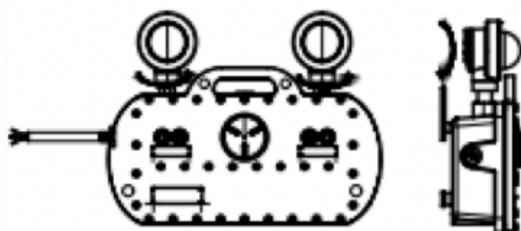

4. After installation, adjust the direction
of the headlights as needed

ESO3 C1 Wall Mounting

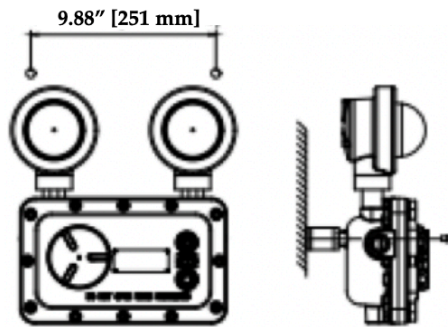

1. Drill four holes as fig. 1
The distance as per
9.88" [251 mm] and 5.19" [132 mm]

Then install the lamp to the wall using 7/16" bolts
(bolts are not provided)

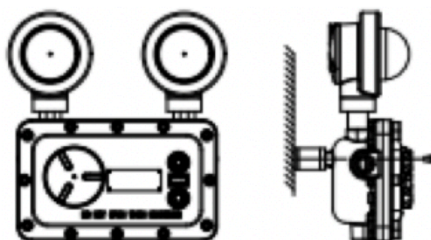

2. Select any one of the three 3/4" NPT plugs
as the interface for the cable input line

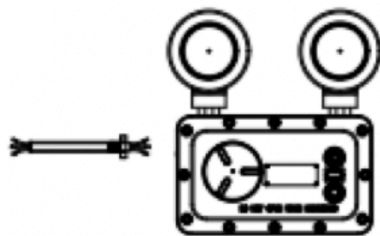

3. Remove the junction box cover (spiral cover) and insert
the power cable into the junction box

Then connect the AC cable:

Black joins to L

White joins to N

Green joined to grounding

Fill 0.63" [16mm] of chemical filler into the conduit
and fix the conduit to the lamp body

-It must be confirmed whether there are suitable gaskets
before installation

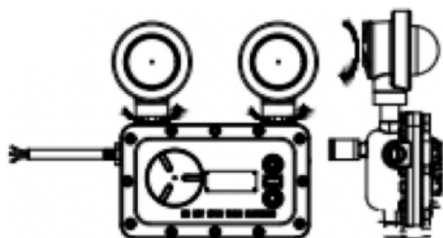

4. After installation, adjust the direction
of the headlights as needed

ESO3 A2 Wall Mounting

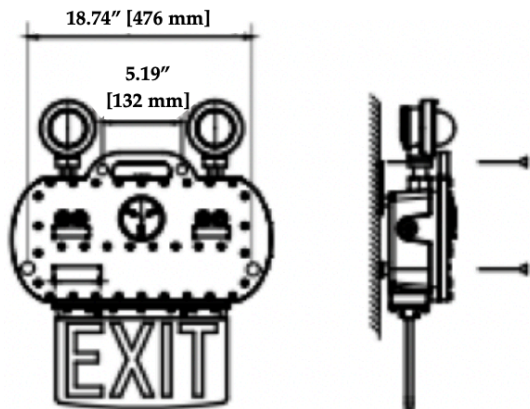

1. Drill four holes as fig. 1
The distance as per
18.74" [476 mm] and 5.19" [132 mm]



2. Fix with four 5/16" expansion screws

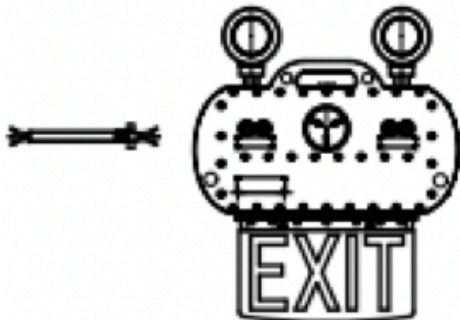

3. Install pipe to 3/4" NPT entry
and fix 0.63" [16mm] chemical filler
Then connect the AC cable:
Black joins to L
White joins to N
Green joined to grounding



4. After installation, adjust the direction
of the headlights as needed

ESO3 A3 Wall Mounting

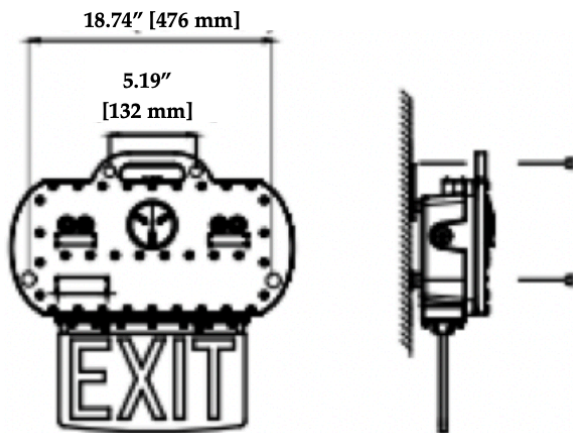

1. Drill four holes as fig. 1
The distance as per
18.74" [476 mm] and 5.19" [132 mm]



2. Fix with four 5/16" expansion screws

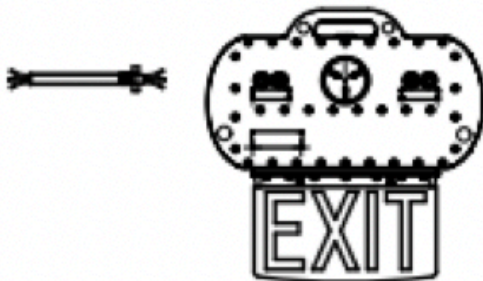

3. Install pipe to 3/4" NPT entry
and fix 0.63" [16mm] chemical filler

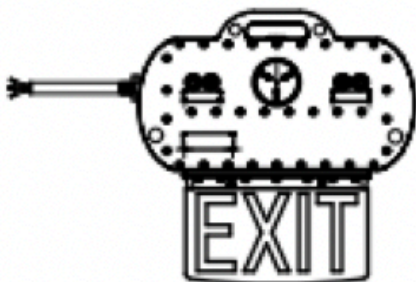

4. Connect the AC cable:
Black joins to L
White joins to N
Green joined to grounding



CAUTION: Before installation, make sure the AC power is off.

- Any installation and maintenance needs to be operated by a licensed electrician.
- Check and confirm all the data and usage surrounding before installation.
- Product is rated to be install the product in damp or wet location.
- Charge the battery consistently for more than 24 hours for the first time usage so as to activate the whole battery cells of discharging/charging duration.
- Do not dismount, change or replace any inside parts. Any difficulties in the process of installation, contact our local distributors or us directly.
- Explosion proof cable introduction devise or explosion proof metal conduit should be used in the process of installation and maintenance, its IP rating and explosive-proof grading should not be lower than the standard indicated on this product label.
- Do not install this product on an incomplete or easy-to-damage surface.
- Overload is strictly prohibited in use.
- For installation or maintenance, cut off power supply and don't open the enclosure in the explosive atmosphere. Before operation, confirm the light source and electrical installation are correctly connected.
- DO NOT COVER LED Luminaires by thermal insulation material, or similar materials.
- In the event of an accident, please turn off the power and contact your local distributor.

Maintenance

- Check the emergency function with the push test button.
- Battery capacity is more than 60% when delivered, so it could be consistently stocked for maximum 12 months.
- The LED circuit board and driver are not replaceable on site.
- Users are not suggested to replace the batteries by themselves. If needed, please use the recommended battery pack by the manufacturer and contact with us for the instructions of maintenance.