

Class 1 Division 2



Key Features

FEATURES: Tunable Wattage
Adjustable CCT

Rugged Linear
High Lumen Efficiency up to 180 lm/W

OPTIONS: 2' & 4' Body Lengths
3 Mounting Styles
T2, T3, T4, 25°, 55°, 90° or 120°
Lens: Clear or Frosted - Flat PC
High Voltage
Emergency Back-Up

Compliance

UL 844 Hazardous Locations
Class I Division 2 Groups A, B, C, D
1598A Marine Outside Type

IP66
IK10
500 Hours Salt Spray
ATEX
IECEX

Applications

Oil and Gas

Petroleum production and refining
Petroleum loading, storage, transportation and retail
Confined spaces with vapor accumulation
LNG and LPG handling
Oil tankers and shipping vessels
Fuel system testing facilities

Power Plants

Coal-fired power plants, including coal handling and storage areas
Gas-fired power plants with fuel storage
Nuclear power facilities in hazardous auxiliary areas
Biomass or waste-to-energy plants with combustible dust risks

Industrial

Industrial storage facilities
Paper mills, sawmills and lumber yards
Loading dock platforms
Manufacturing plants for heavy industrial goods
Warehouses handling flammable materials

Waste Treatment

Wastewater treatment plants
Pumping stations
Solid waste processing and incineration facilities
Sewage treatment with methane gas risks
Hazardous waste recycling centers

Mining

Operations and service areas
Underground mining tunnels with gas accumulation

Chemical Industry

Chemical production, processing and storage facilities
Solvent handling and mixing areas
Chemical research labs with flammable substances

Ocean, Marine and Aerospace

Offshore platform operation facilities and structures
Marine and saltwater environments
Aerospace clean rooms and production areas
Ocean vessel operations
Shipyards and dry docks
Aircraft hangars with fuel vapors

Metal Treatment

Paint facilities
Steel and aluminum factories
Metal smelting, foundry and fabrication
Welding and cutting areas with gas risks

Military and Defense

Ammunition storage and handling
Fuel depots and refueling stations
Explosives manufacturing
Vehicle maintenance bays in hazardous zones

Food, Alcohol and Agriculture Industry

Flour and fine particle production and storage
Food and distilling production
Grain storage elevators and silos
Breweries and fermentation tanks
Feed mills with dust risks
Fertilizer production and storage

Pharmaceutical Industry

Drug manufacturing and solvent handling
Clean rooms with volatile compounds
Pill coating and drying areas
Research and development labs

Other high humidity, high dust, high temperature and vapor locations

Specifications

Wattage	30 W	35 W	40 W	50 W	55 W	60 W	70 W	75 W	35 W	40 W	50 W	55 W	60 W	70 W	80 W	100 W	120 W	140 W
Body	FLGB2								FLGB4									

OPTICAL

Lumen Output	5400 lm	6300 lm	7200 lm	9000 lm	9900 lm	10800 lm	12600 lm	13500 lm	6300 lm	7200 lm	9000 lm	9900 lm	10800 lm	12600 lm	14400 lm	18000 lm	21600 lm	25200 lm
Lumens Per Watt	180 lm/W																	
Color Temperature: CCT	SELECTABLE: Standard 5000K Options: 2000K- 7500K																	
CRI (Color Rendering Index)	>70																	
Beam Angle	Standard: 120° Options: 25°/55°/90°/T2/T3/T4																	
Dimming	0-10V dimming																	

ENVIRONMENTAL

Ambient Operating Temperature	T5: -40°C to +65°C (-40°F to 149°F)	T5: -40°C to +55°C (-40°F to 131°F)
Temperature Code	T5: +65°C (60W)	T5: +55°C (120W)
Power Model (120-277VAC/347VAC)	SS-75VP-56BH	SS-150VP-56BH
Power Model (277-480 VAC)	HVG-100-48AB	HVG-150-48AB
Power Model (120-347 VAC)	SS-75EP-M54BH	2*SS-100EP-M54BH

MECHANICAL

Housing Material	Aluminum
Lens Diffuser	Standard: Clear Flat PC Options: Clear Flat PC, Frosted Flat PC
Hardware	SUS 304
Finish	Corrosion Resistant
Fixture Color	Grey
Mounting	Ceiling, Pole, Guide Rail
Cable Entry	3/4" NPT
Outlet	One wiring access cover with captive screws on both sides. Wiring is not included, It can be customized if required
Chip Lens	Polycarbonate (PC)
Warranty	5-Year Standard Warranty

ELECTRICAL	
Lifespan	L70> 71,000 Operational Hours @ 25°C
Input Voltage	AC100-277VAC; AC100-347VAC; AC200-480VAC
Input Frequency	50/60Hz
Power Factor	> 0.95

EMERGENCY	
Emergency Time	1.5 Hour, 3 Hour
Rated Power in Emergency Mode	8W (A Series)

Ordering Logic

ORDER EXAMPLE: HLL T EX 60W FLGB2 D 50 D120 T

(1) Product (2) Product Category (3) Wattage (4) Shape Series (5) Dimming

HLL T	EX - Explosion Proof	60W: 60W/40W/30W [FLGB2] 120W: 120W/100W/80W [FLGB4] Inquire About Additional Wattage Combinations: FLGB2: 30W/35W/40W/50W/55W/60W/70W/75W FLGB4: 35W/40W/50W/55W/60W/70W/80W/100W/120W/140W	FLGB2 FLGB4	Blank - Non-Dimmable D - Dimmable (S)
-------	----------------------	--	----------------	--

(6) Kelvin (7) Beam Angle (8) Lens (9) Tunable (10) Backup Power Source

20 - 2000 K	D25 - 25°	CFP or Blank - Clear Flat PC (S)	T - Tunable	Blank - Without Emergency Function (S)
30 - 3000 K	D55 - 55°	FFP - Frosted Flat PC		EM - Emergency Back Up
40 - 4000 K	D90 - 90°			
50 - 5000 K (S)	D120 - 120° (S)			
57 - 5700 K	T2 - 60°			
65 - 6500 K	T3 - 90°			
75 - 7500 K	T5 - 120°			

(S) Standard

Accessories



Regular Bracket



Pole Mounting



Guide Rail

Product Dimensions

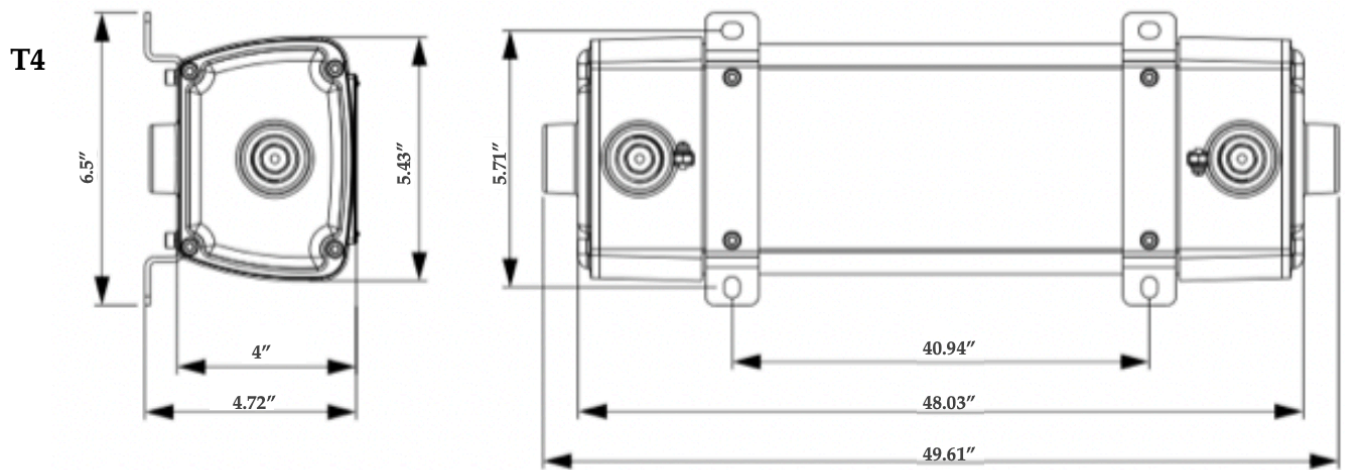
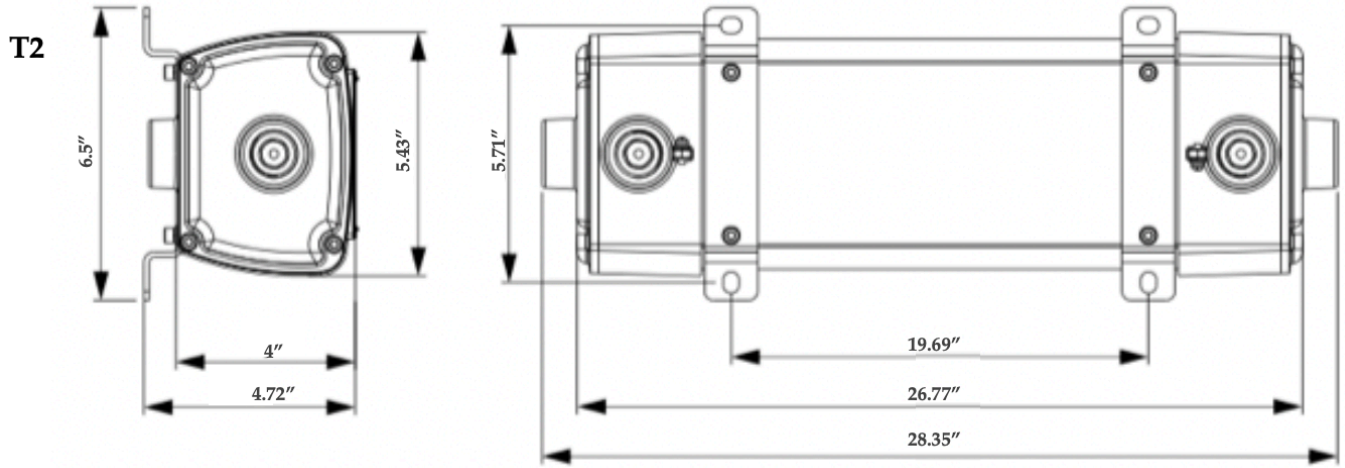

Packaging Information

	FLGB2	FLGB4
Pieces	1	1
Fixture Dimensions	See Product Dimensions Drawing	See Product Dimensions Drawing
Package Dimensions	33.27" x 8.90" x 8.46" (845mm x 226mm x 215mm)	54.53" x 8.90" x 8.46" (1385mm x 226mm x 215mm)
Net Fixture Weight	12.79 lb (5.8kg)	19.29 lb (8.75 kg)
Gross Weight	14.15 lb (6.42 kg)	20.93 lb (9.54kg)

Mounting Methods

Option 1: Ceiling Mount

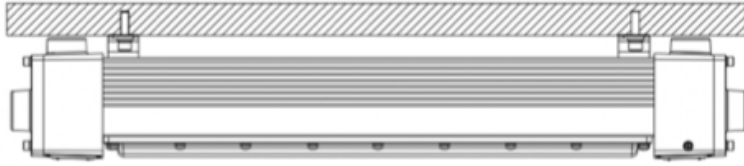

Accessory



Regular Bracket

Option 2: Pole Mount

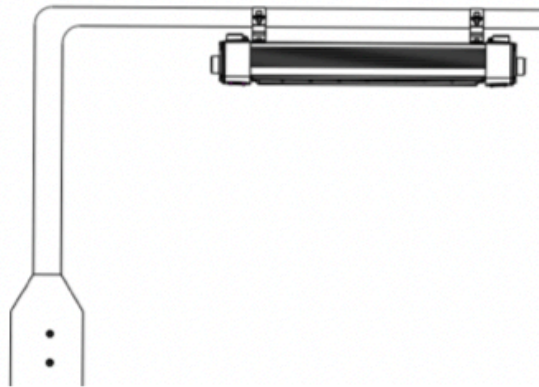

Accessory



Pole Mount

Option 3: Guide Rail Mount

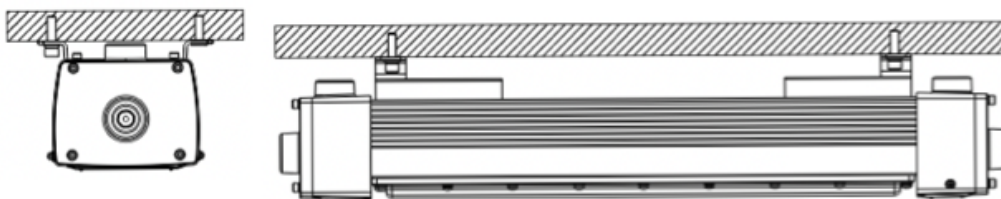

Accessory



Guide Rail

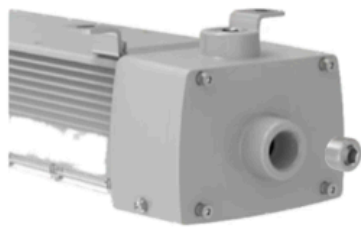



OPERATING INSTRUCTIONS

S1 DIP SWITCH - RED (S1 Power adj.)

The power adjustment dial switch can be set to three power levels, and the factory default setting can be defined according to order requirements.

- 

1. First gear (Max. power), 100% full power.
 Operation instructions: Dial 1 and 2 are both in the OFF position;
 Example: 100W
- 

2. Second gear (Mid. power), 70%-80% power, can be set according to the required power.
 Operation instructions: Dial 1 is in the ON position, Dial 2 is in the OFF position;
 Example: 80W
- 

3. Third gear (Min. power), 50%-60% power, can be set according to the required power.
 Operation instructions: Dial 1 is in the OFF position, Dial 2 is in the ON position;
 Example: 60W

S2 DIP SWITCH - BLUE (S2 CCT adj.)

The color temperature dial switch can be set to three levels of color temperature, and the factory default setting can be defined according to order requirements.

- 

1. First gear, the cold white temperature gear, for example, 6500K.
 Operation instructions: Dial 1 and 2 are both in the OFF position;
 Example: 6500K
- 

2. Second gear, the neutral temperature gear, for example, 5000K.
 Operation instructions: Dial 1 is in the ON position, and Dial 2 is in the OFF position;
 Example: 5000K
- 

3. Third gear, the warm white temperature gear, for example, 4000K.
 Operation instructions: Dial 1 and 2 are both in the ON position;
 Example: 4000K

(1) Power Adjuster:

Connect to the 0/1-10V dimming port of the LED driver.

(2) CCT Adjuster:

Connect the output voltage of the LED driver:

DC20 - 60V LED driver maximum no - load output voltage: 68V max

(3) The three - gear power setting principle is as follows:

The first gear is 100%, the second gear is 70 - 80%, and the third gear is 50 - 60%.

The minimum setting cannot be lower than 50%.