



STEM

**CATALOGO** ■

**SISTEMI LEGNO-ALLUMINIO** ■



OLTRE  
CIO' CHE VEDI!







SYSTEM

**ALL**

OLTRE  
CIO' CHE VEDI!

Misura interno telaio

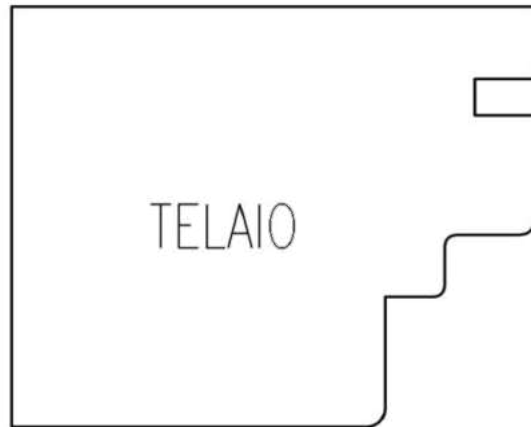

TELAIO

Misura esterno telaio

Misura interno anta

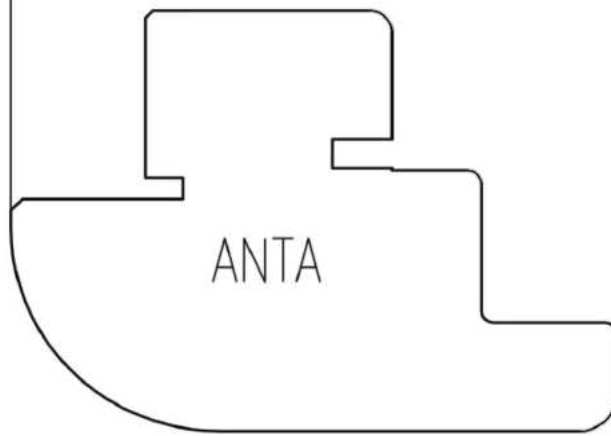

ANTA

Misura esterno anta

			Sistema <b>ASTRO 6</b> 06S
Cliente Standard	REV. 05		Scala Disegno 1:1
Descrizione: <b>SCHEMA SEMPLIFICATIVO DI RILEVAMENTO MISURE</b>			Tolleranze Generali ± 0,5 mm
Mod_35_REV01			PAGINA <b>006</b>

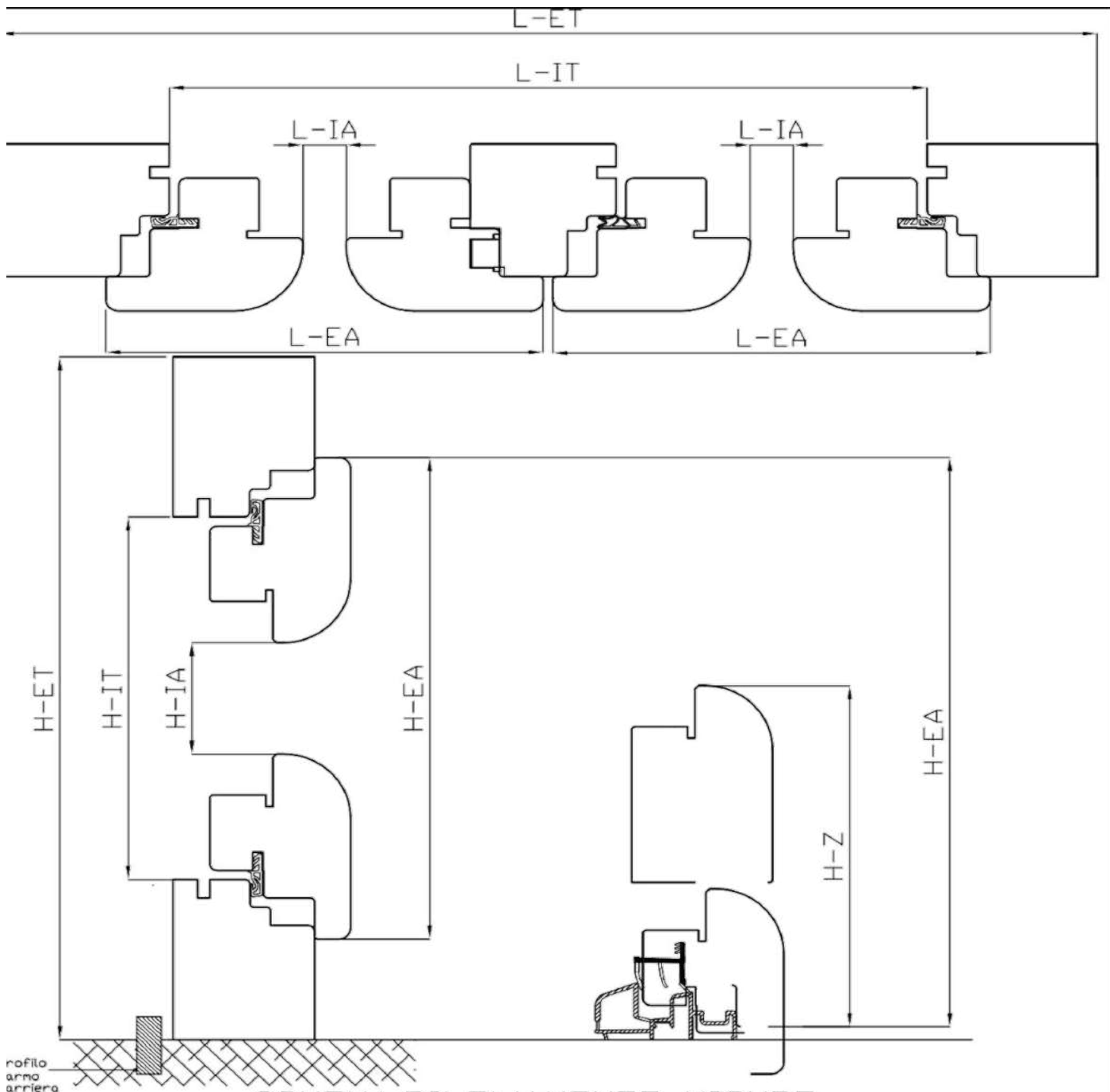

SCHEMA RILEVAMENTO MISURE

- L-ET LARGHEZZA ESTERNA TELAIO
- L-EA LARGHEZZA ESTERNA ANTA
- L-IT LARGHEZZA INTERNA TELAIO
- L-IA LARGHEZZA INTERNA ANTA
- H-ET ALTEZZA ESTERNA TELAIO
- H-IT ALTEZZA INTERNA TELAIO
- H-IA ALTEZZA INTERNA ANTA
- H-EA ALTEZZA ESTERNO ANTA
- H-Z ALTEZZA ANTA + ZOCCOLI

NEL CASO DI PORTAFINESTRE EVIDENZIARE SE SI TRATTA DI TRAVERSO INFERIORE CON SOGLIA O PARAFREDDO

			Sistema <b>ASTRO 6</b> 06S
	Cliente Standard		Scala Disegno Fuori Scala
			Tolleranze Generali ---
Descrizione:	<b>SCHEMA SEMPLIFICATIVO DI RILEVAMENTO MISURE</b>		PAGINA <b>007</b>

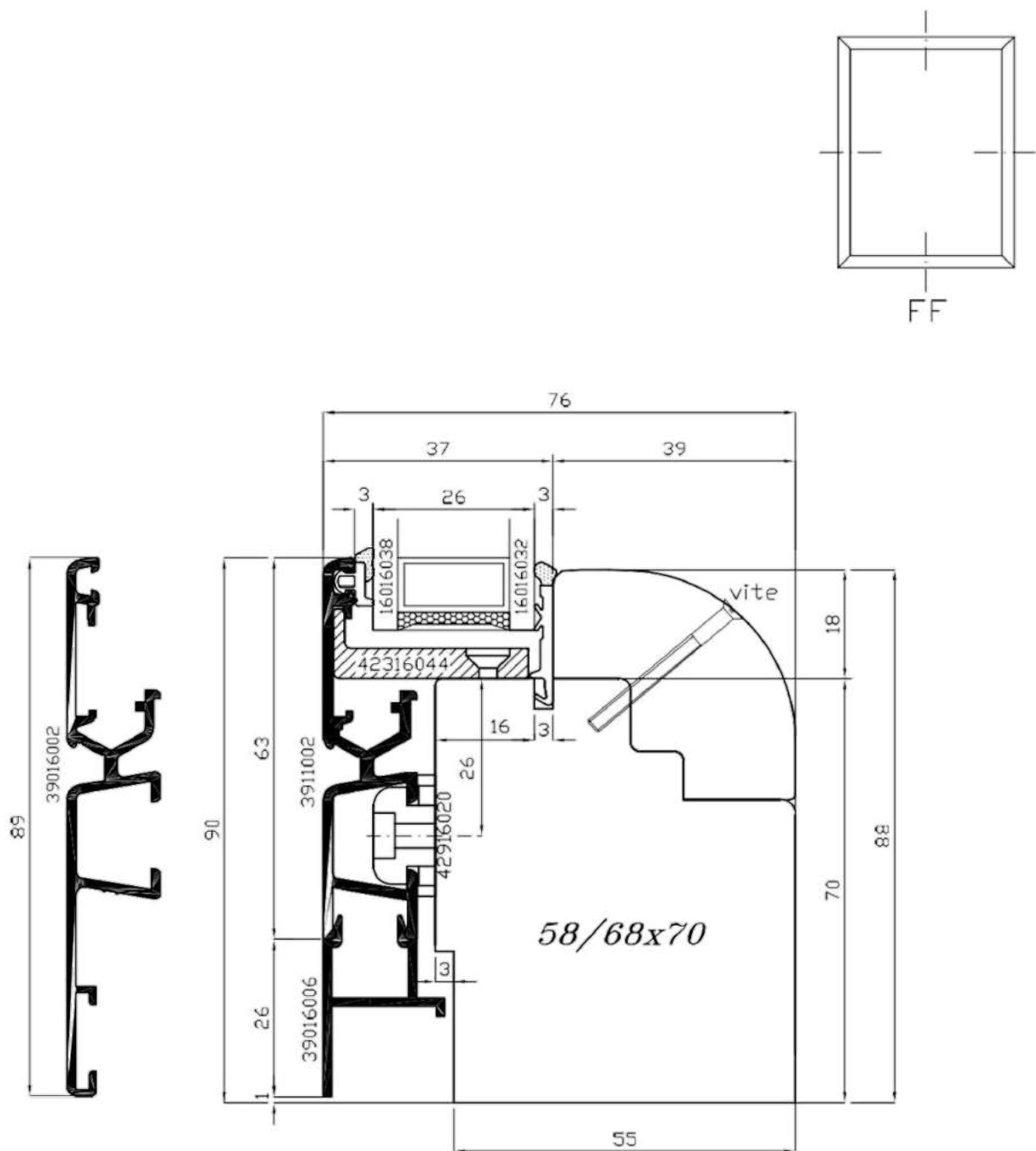

Attenzione: finestra fissa. Fissare con vite su telaio accessorio cod. 42316044 come supporto per profilo 3911002 con interasse 150mm

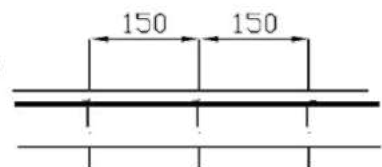

			Sistema <b>ASTRO 6</b> 06S
	Cliente Standard		Scala Disegno 1:1
			Tolleranze Generali ± 0,5 mm
Descrizione:	<b>SEZIONE VERTICALE INFERIORE VETRO FISSO</b>		PAGINA
Mod_35_REV01			<b>03</b>

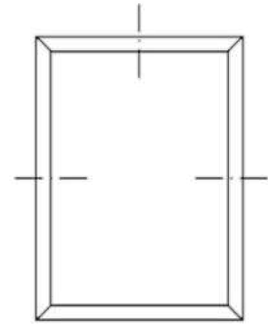

FF

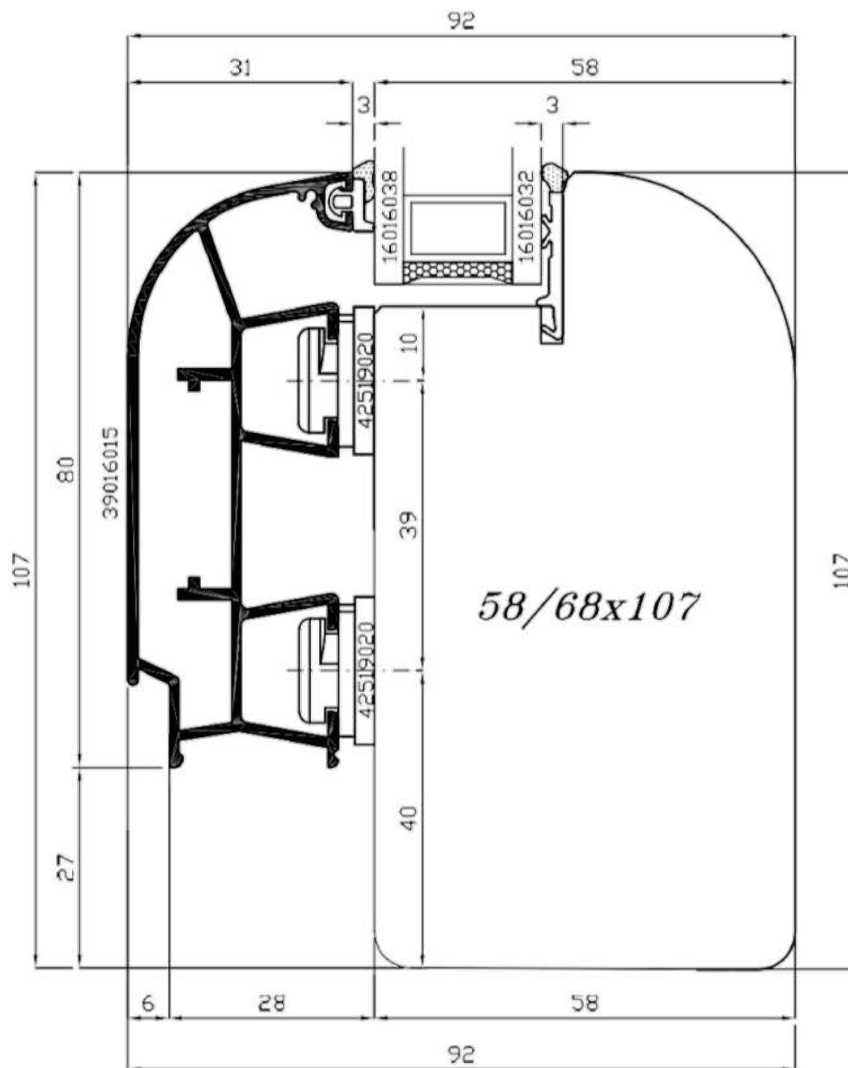

			Sistema <b>ASTRO 6</b> 06S
Approvato da : G.N.	Cliente Standard		Scala Disegno 1:1
			Tolleranze Generali ± 0,5 mm
Descrizione: <b>SEZIONE VERTICALE E ORIZZONTALE VETRO FISSO</b>			PAGINA <b>04</b>
Mod_35_REV01			

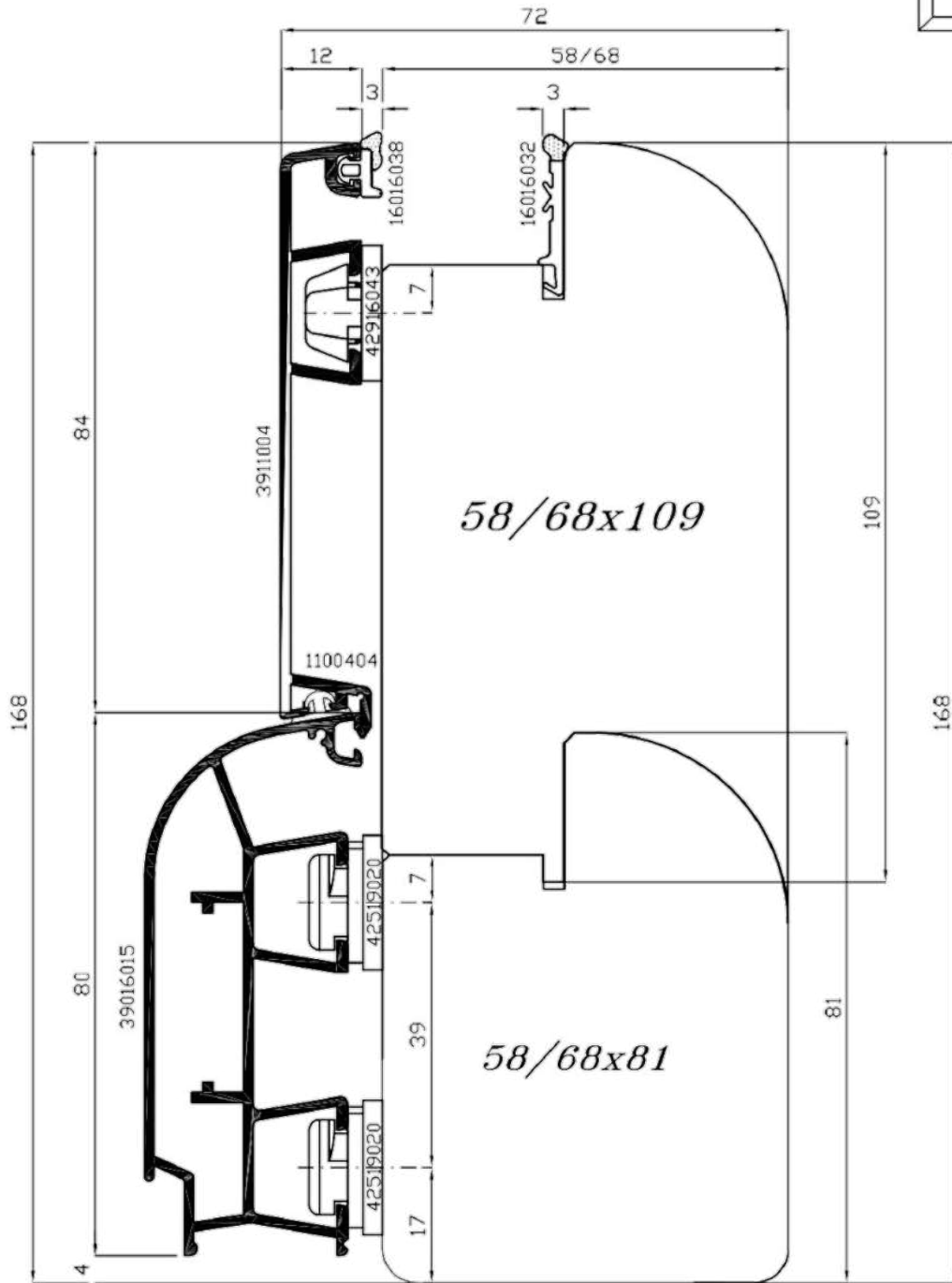

				Sistema <b>ASTRO 6</b> 06S
Cliente Standard			REV. 04	Scala Disegno 1:1
				Tolleranze Generali ± 0,5 mm
Descrizione: <b>SEZIONE VERTICALE E ORIZZONTALE INFERIORE VETRO FISSO</b> Mod_35_REV01				PAGINA <b>05</b>

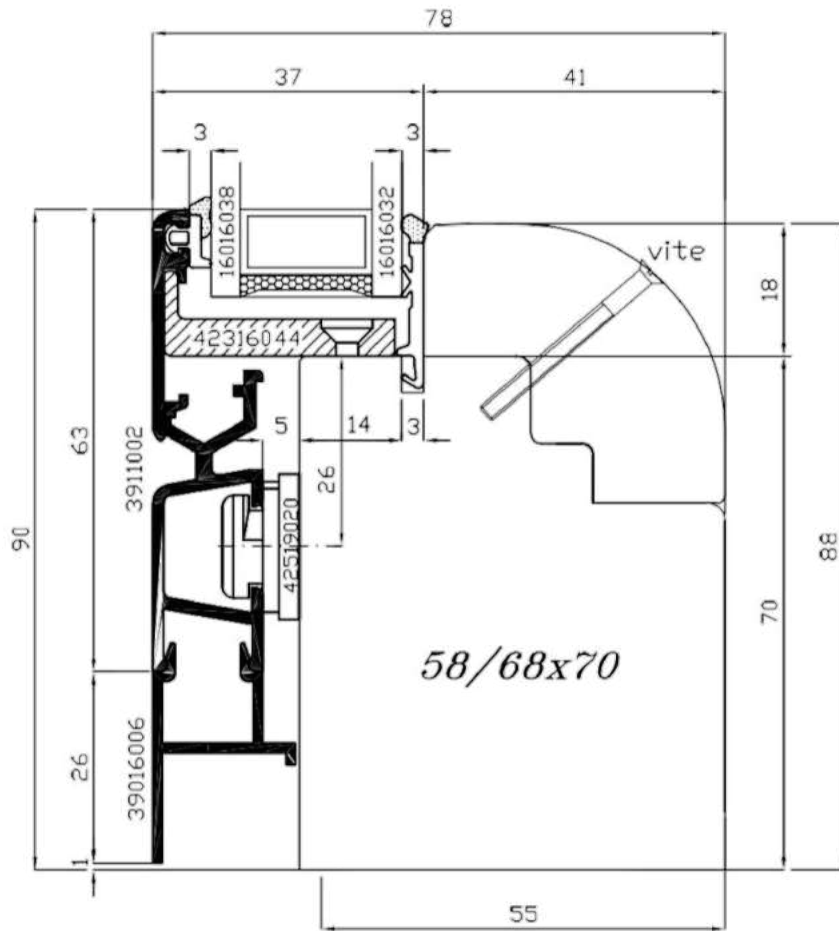
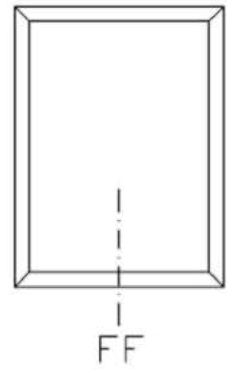

58/68x70

vite

Attenzione: finestra fissa. Fissare con vite su telaio accessorio cod. 42316044 come supporto per profilo 3911002 con interasse 150mm

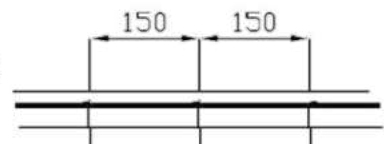

			Sistema <b>ASTRO 6</b> 06S
	Cliente Standard		Scala Disegno 1:1
			Tolleranze Generali ± 0,5 mm
Descrizione:	<b>SEZIONE VERTICALE INFERIORE VETRO FISSO</b>		FACINA
Mod_35_REV01			<b>06</b>



Attenzione: finestra fissa. Fissare con vite su telaio  
 accessorio cod. 42316044 come supporto per profilo  
 3911002 con interasse 150mm

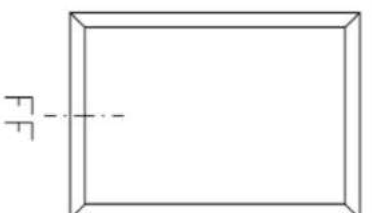
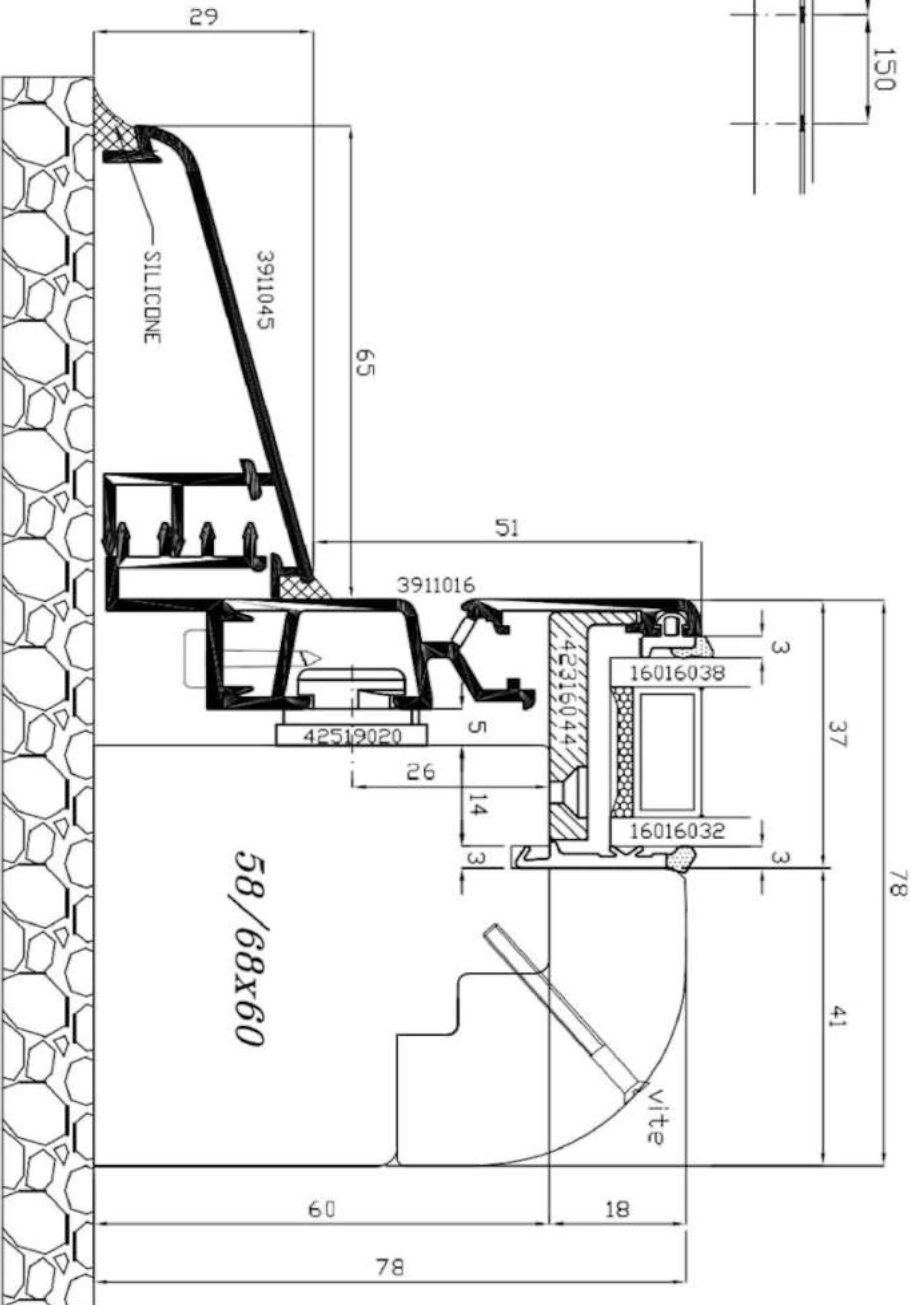
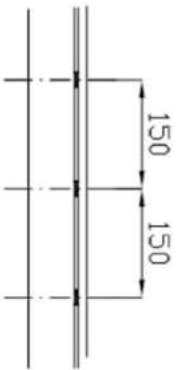

Disegnatore : L.F.	Data Emissione 14/04/2006		File:06s301v4_060414	Sistema <b>ASTRO 6</b>	06S
Approvato da : C.N.	Cliente Standard		REV. 00	Scala Disegno	1:1
Descrizione: <b>SEZIONE VERTICALE          INFERIORE VETRO FISSO</b>			Tolleranze Generali	± 0,5 mm	
Mod_35_REV01			PAGINA	<b>301v4</b>	



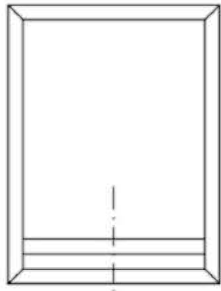

FF

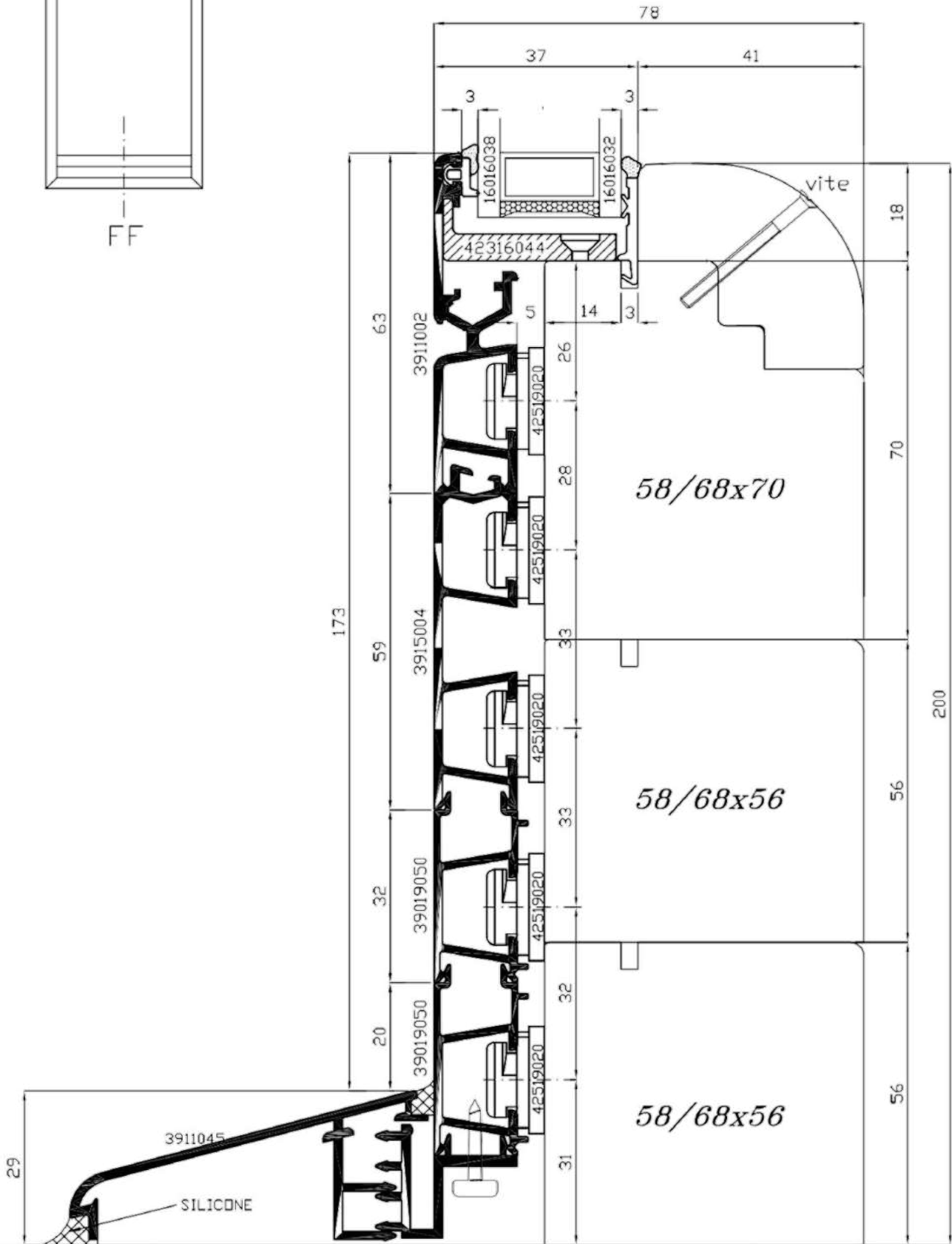

Approvato da : G.N. Cliente Standard			Sistema <b>ASTRO 6</b> 06S
			Scala Disegno 1:1
			Tolleranze Generali ± 0,5 mm
Descrizione: <b>SEZIONE VERTICALE INFERIORE VETRO FISSO</b>		PAGINA <b>08</b>	
Mod_35_REV01			

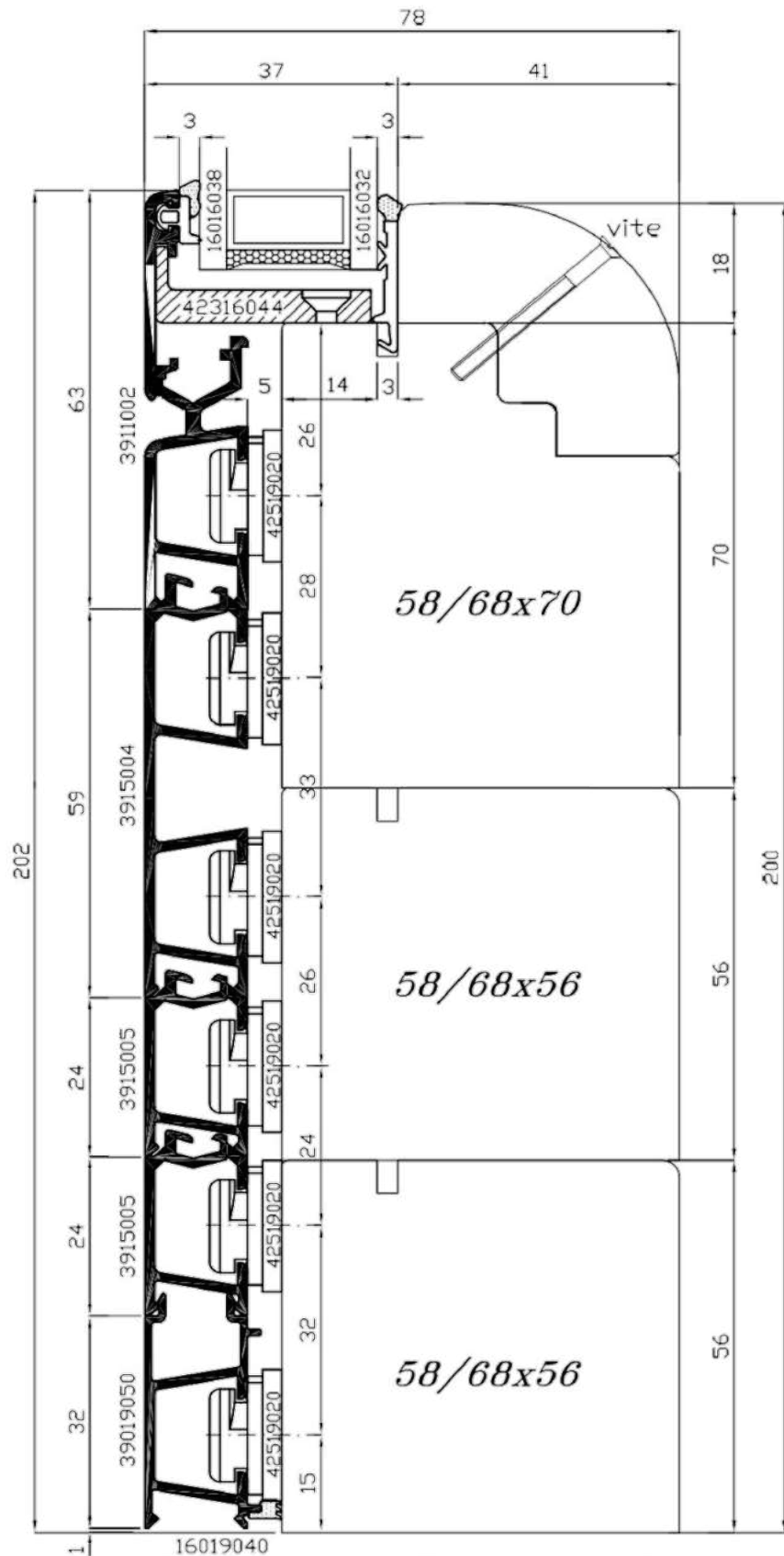
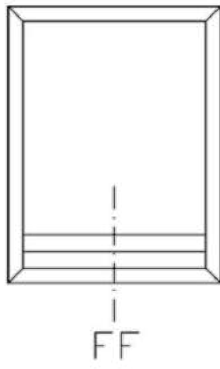

			File:06s301v7_060413	Sistema <b>ASTRO 6</b> 06S
Cliente Standard			REV. 00	Scala Disegno 1:1 Tolleranze Generali ± 0,5 mm
Descrizione: <b>SEZIONE VERTICALE INFERIORE VETRO FISSO</b>			FACINA <b>301v7</b>	

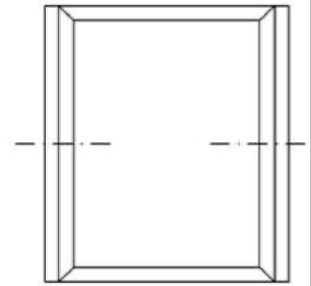

FF\_gp

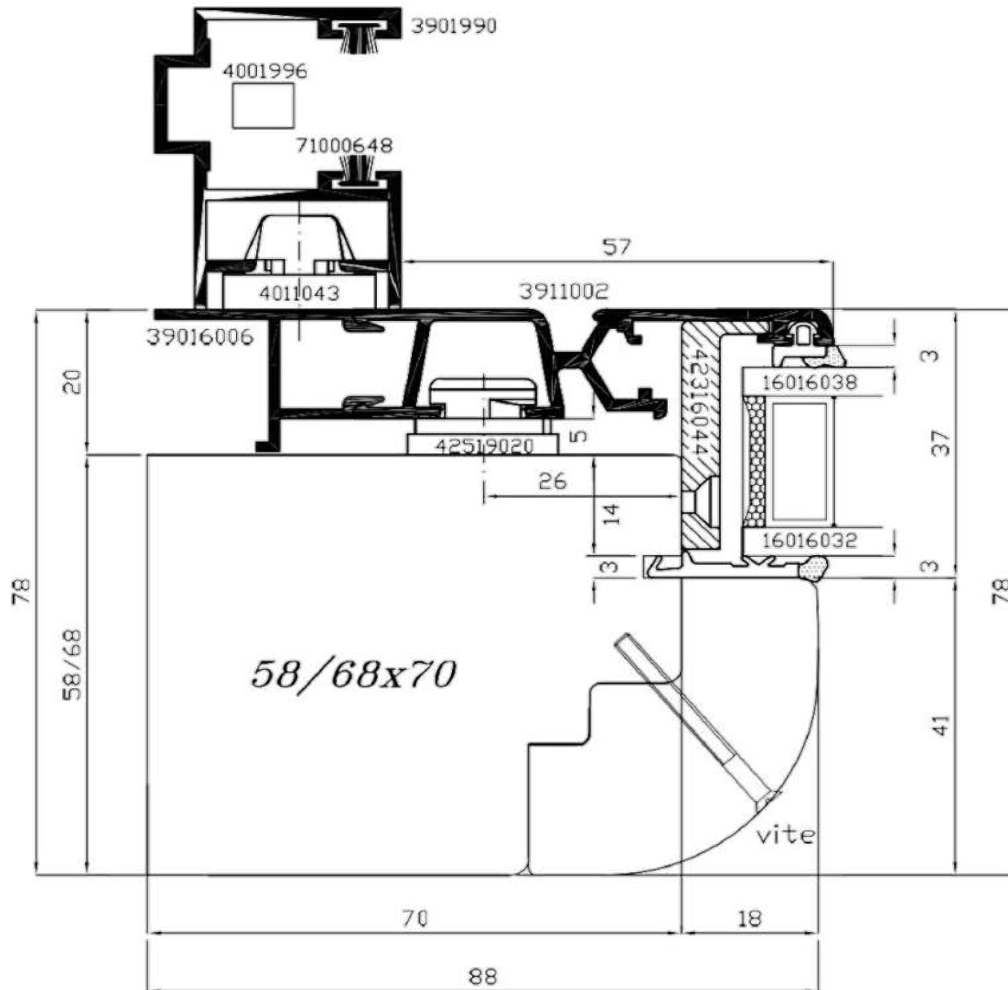

Attenzione: finestra fissa. Fissare con vite su telaio accessorio cod. 42316044 come supporto per profilo 3911002 con interasse 150mm

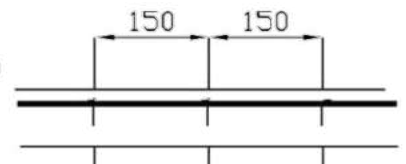

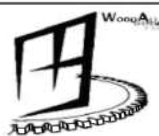
			Sistema <b>ASTRO 6</b> 06S
	Cliente Standard		Scala Disegno 1:1
Descrizione: <b>SEZIONE VERTICALE MONTANTI CON GUIDA PERSIANA</b>			Tolleranze Generali ± 0,5 mm
Mod_35_REV01			FACINA <b>09</b>

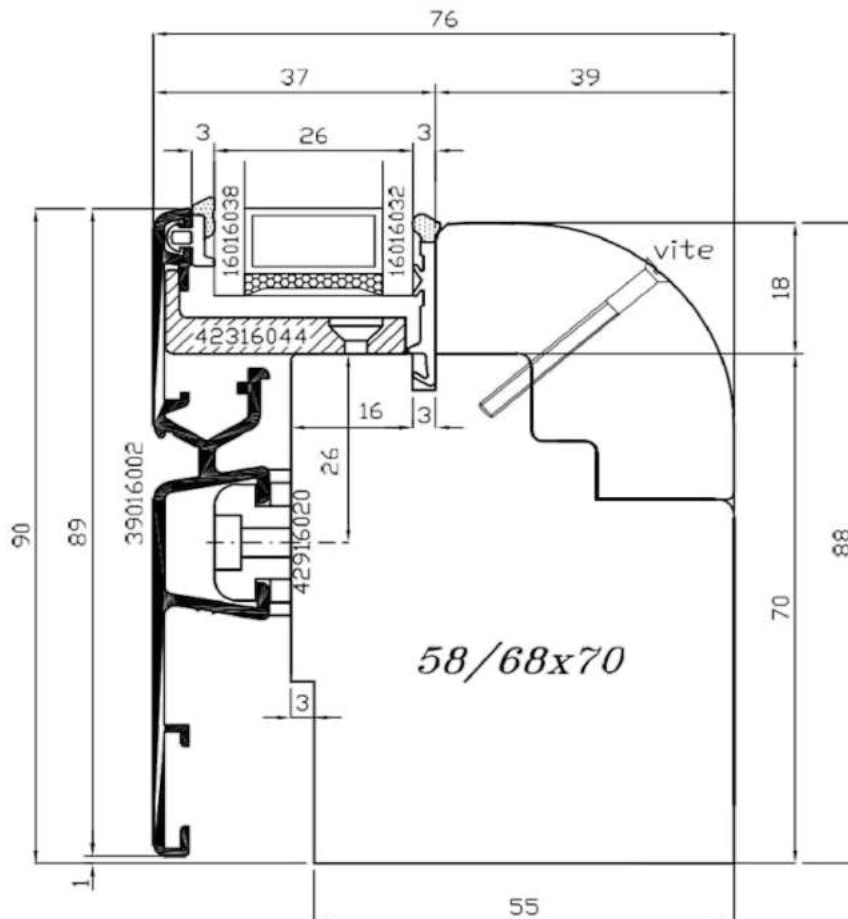
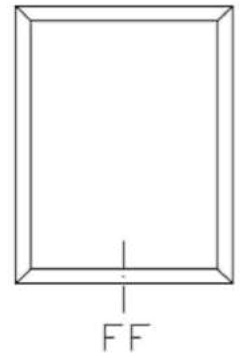

Attenzione: finestra fissa. Fissare con vite su telaio accessorio cod. 42316044 come supporto per profilo 3911002 con interasse 150mm

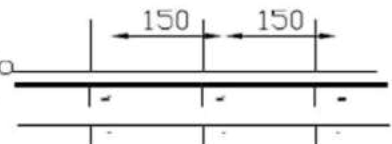

Disegnatore : L.F. Data Emissione 10/10/2006  
 Approvato da : G.N. Cliente Standard



File:06s301v9\_061010  
 REV. 00

Sistema **ASTRO 6** 06S

Scala Disegno 1:1

Tolleranze Generali ± 0,5 mm

Descrizione:

**SEZIONE VERTICALE  
 INFERIORE VETRO FISSO**

PAGINA

**301v9**

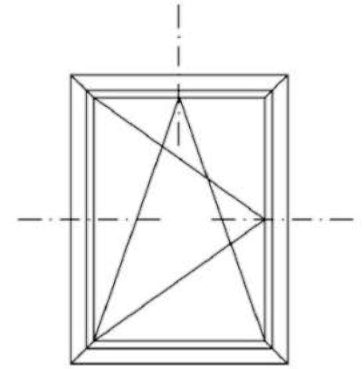
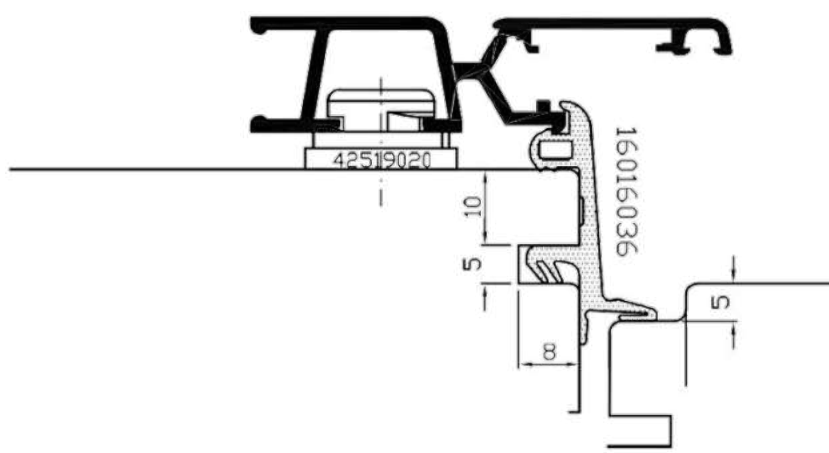

F1A

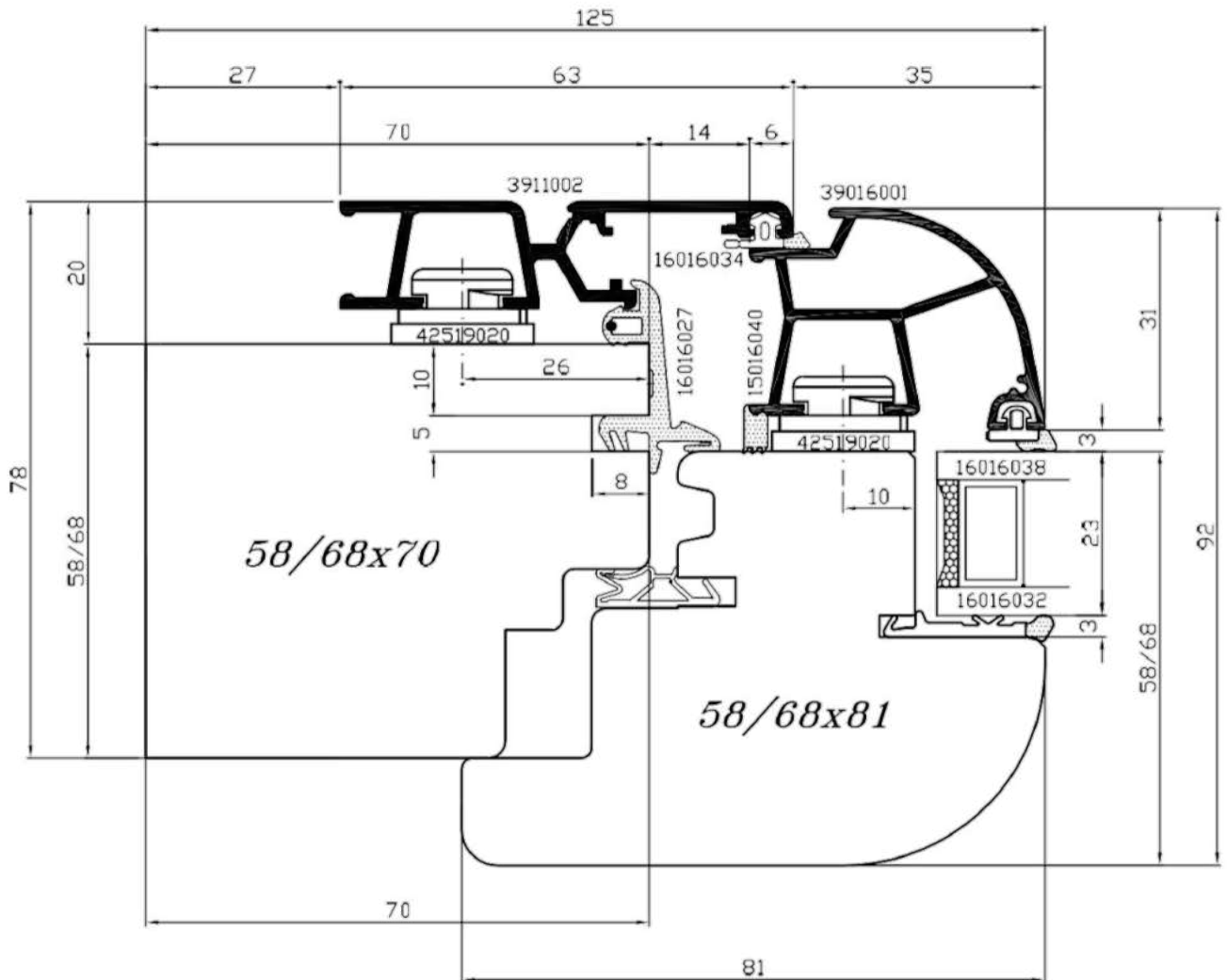

			Sistema <b>ASTRO 6</b> 06S
	Cliente Standard		Scala Disegno 1:1
			Tolleranze Generali ± 0,5mm
Descrizione: <b>SEZIONE VERTICALE E ORIZZONTALE</b>			PAGINA
Mod_35_REV01			

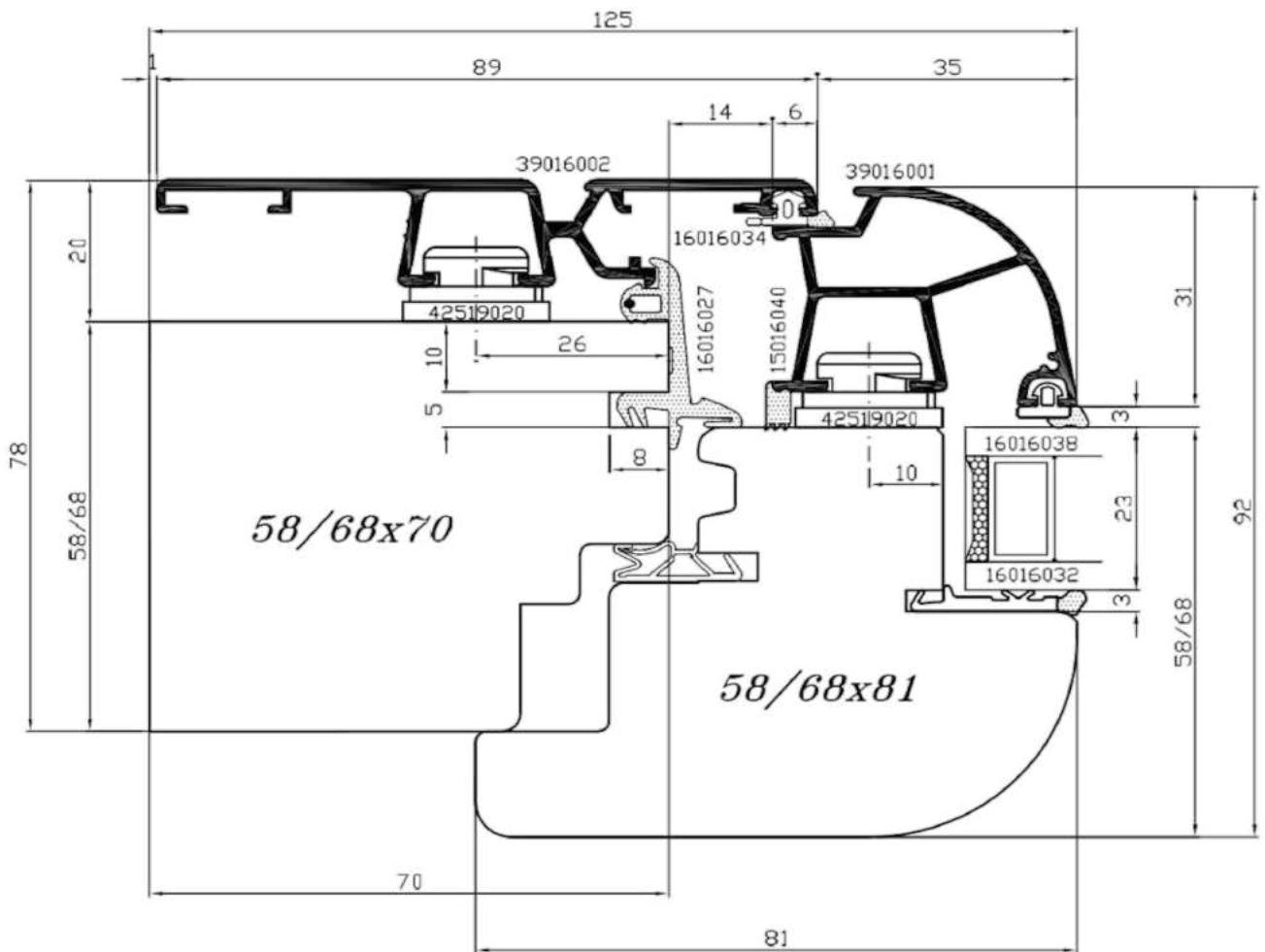
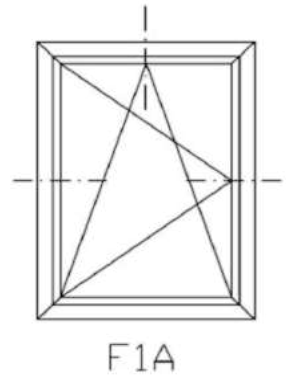
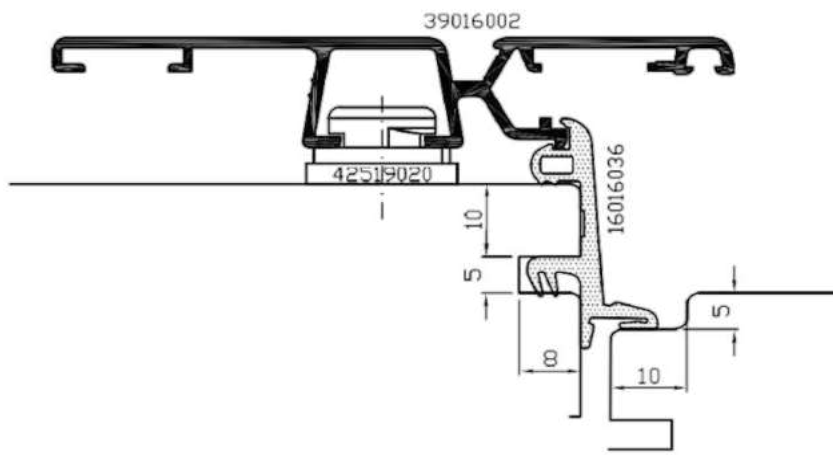

Disegnatore : L.F. Data Emissione 09/02/2006

Approvato da : G.N. Cliente Standard



File:06s302v1\_060209

REV. 04

Sistema **ASTRO 6** 06S

Scala Disegno 1:1

Tolleranze Generali  $\pm 0,5\text{mm}$

Descrizione:

**SEZIONE VERTICALE  
E ORIZZONTALE**

PAGINA

**302v1**



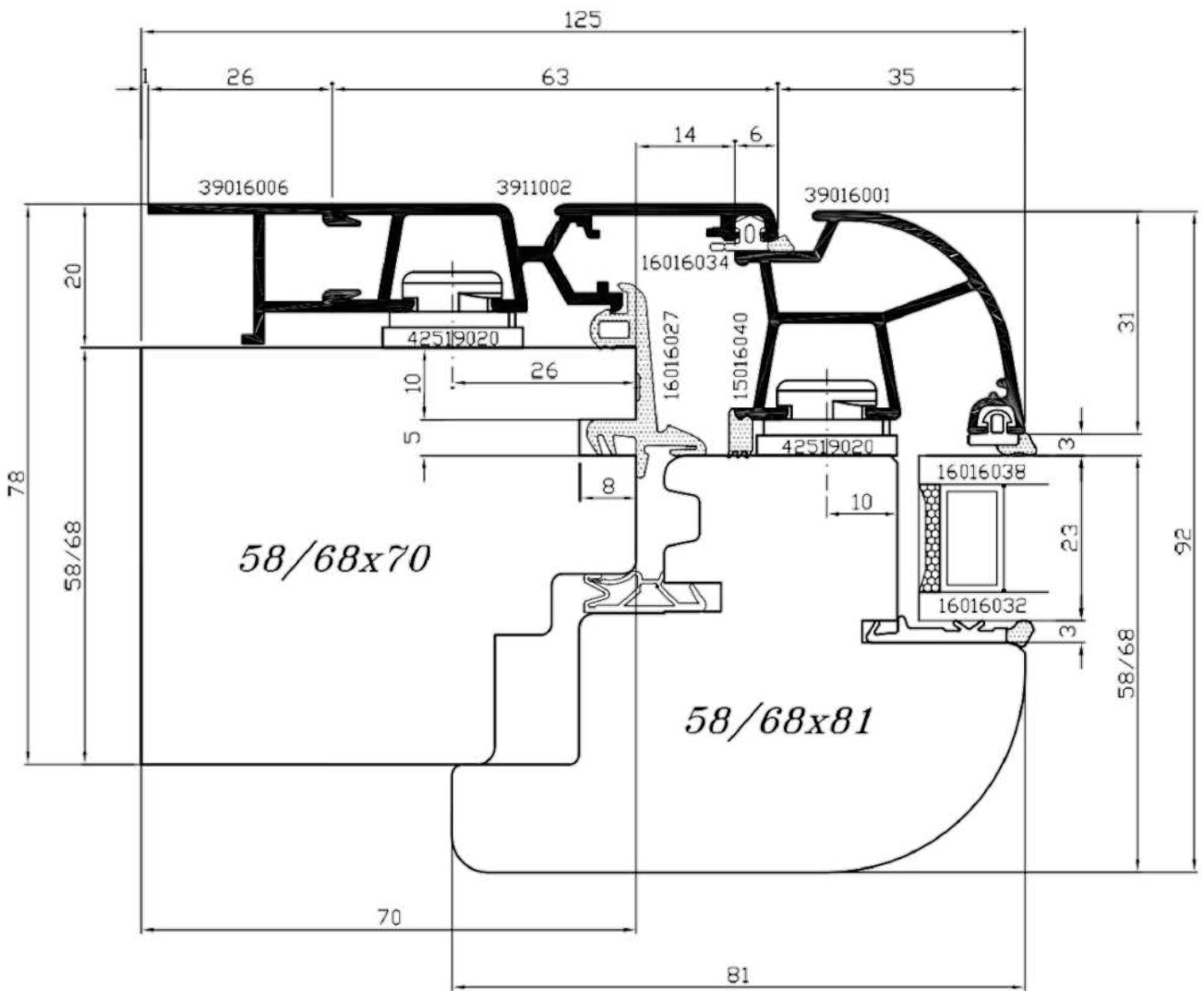
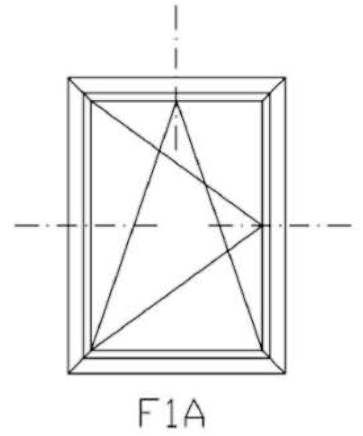

			Sistema <b>ASTRO 6</b> 06S
	Cliente Standard		Scala Disegno 1:1
			Tolleranze Generali ± 0,5mm
Descrizione: <b>SEZIONE VERTICALE E ORIZZONTALE</b>			PAGINA <b>10</b>
Mod_35_REV01			

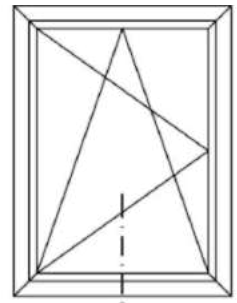

F1A

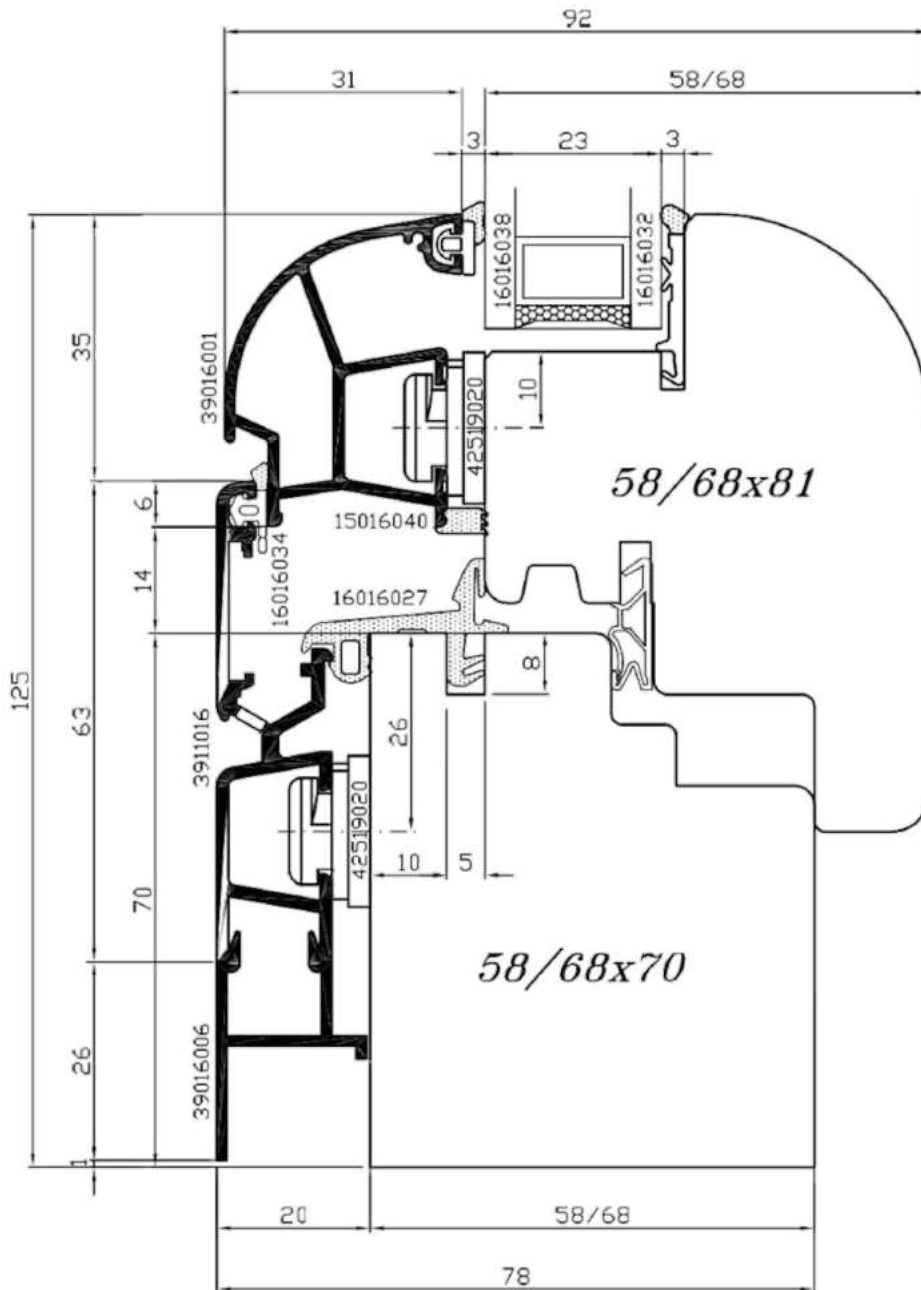



Approvato da : G.N. Cliente Standard			Sistema <b>ASTRO 6</b> 06S
			Scala Disegno 1:1
			Tolleranze Generali ± 0,5 mm
Descrizione: <b>SEZIONE VERTICALE TRAVERSO INFERIORE FINESTRA</b>			PAGINA 11
Mod_35_REV01			

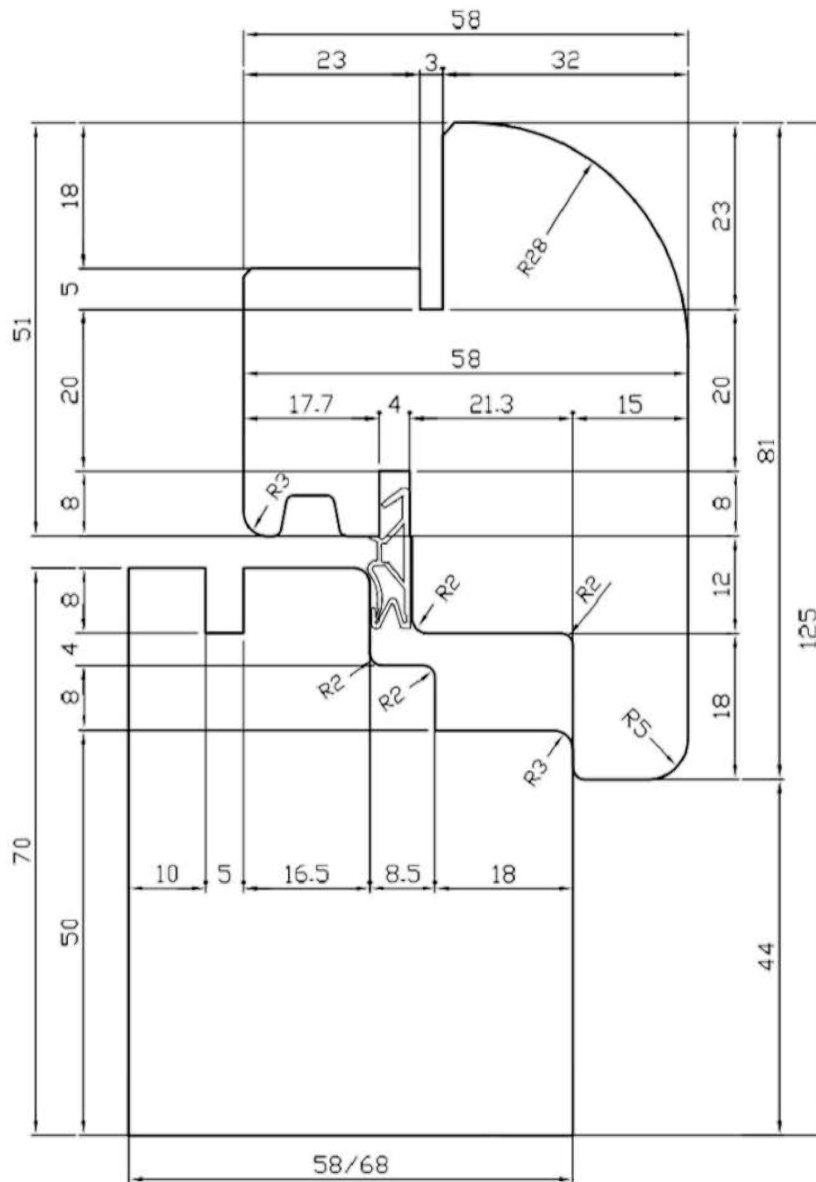
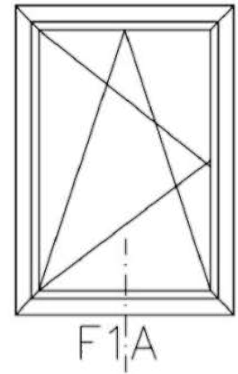

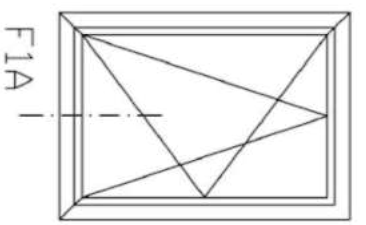
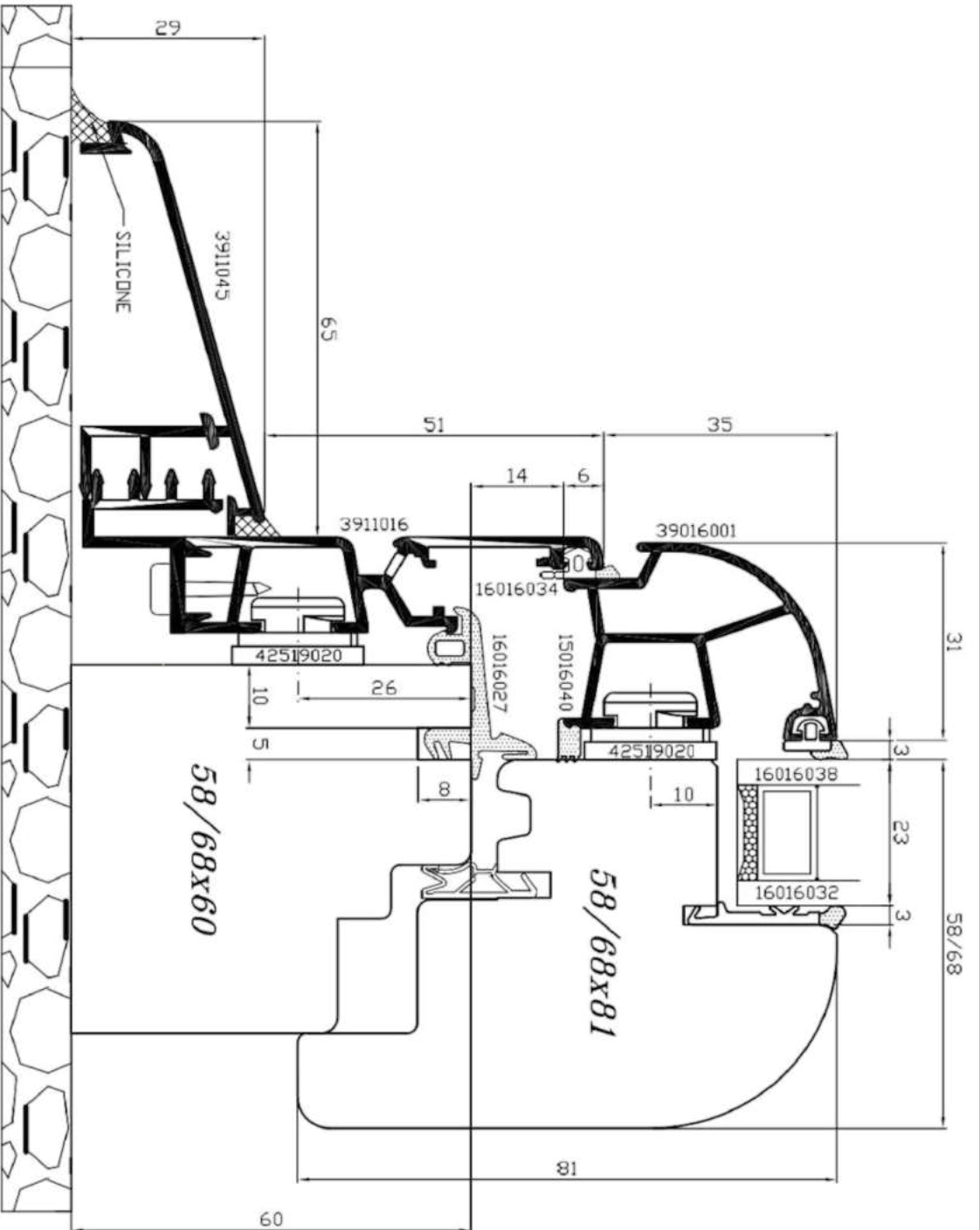

	Cliente Standard		Sistema <b>ASTRO 6</b> 06S
			Scala Disegno 1:1
			Tolleranze Generali ± 0,5 mm
Descrizione: <b>SEZIONE VERTICALE TRAVERSO INFERIORE FINESTRA</b>			PAGINA
Mod_35_REV01			<b>12</b>



Disegnatore :	L.F.	Data Emissione	16/02/2005		File:06s303v1_050216	Sistema	<b>ASTRO 6</b>	06S
Approvato da :	G.N.	Cliente	Standard		REV. 04	Scala Disegno		1:1
Descrizione: <b>SEZIONE VERTICALE</b> <b>TRAVERSO INFERIORE FINESTRA</b>				Tolleranze Generali		± 0,5 mm		
Mod.:35_RP001				PAGINA		<b>303v1</b>		

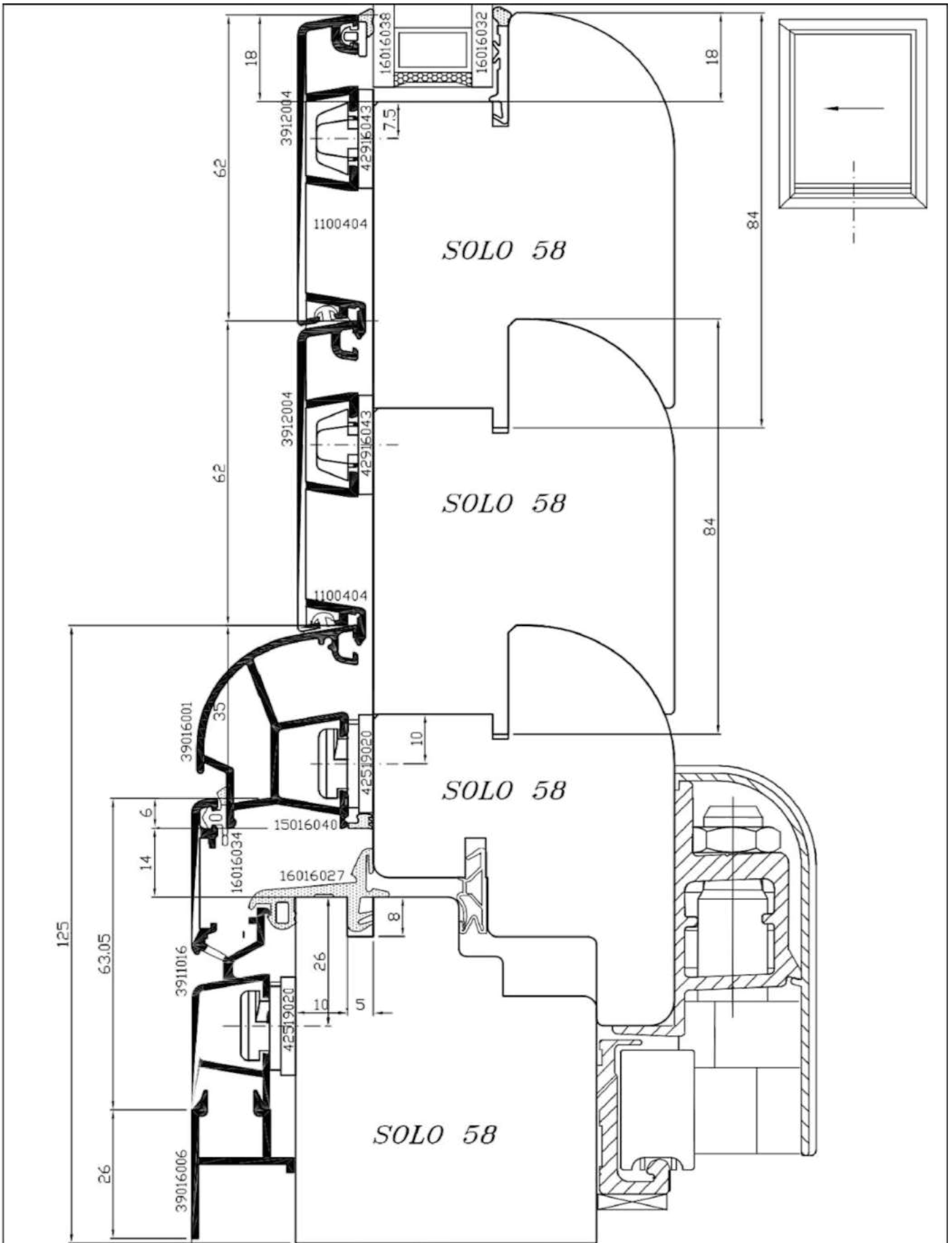

Disegnatore : L.F. Data Emissione 17/02/2005

Approvato da : G.N. Cliente Standard



File:09s303v2\_050217

REV. 04

Sistema **ASTRO 6** 09S

Scala Disegno 1:1

Tolleranze Generali  $\pm 0,5$  mm

Descrizione: **SEZIONE VERTICALE TRAVERSO INFERIORE  
CON GUIDA INFERIORE PER SCORREVOLE TRASLANTE**

PAGINA

**303v3**

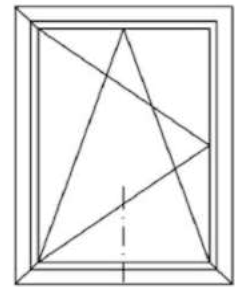

F1A

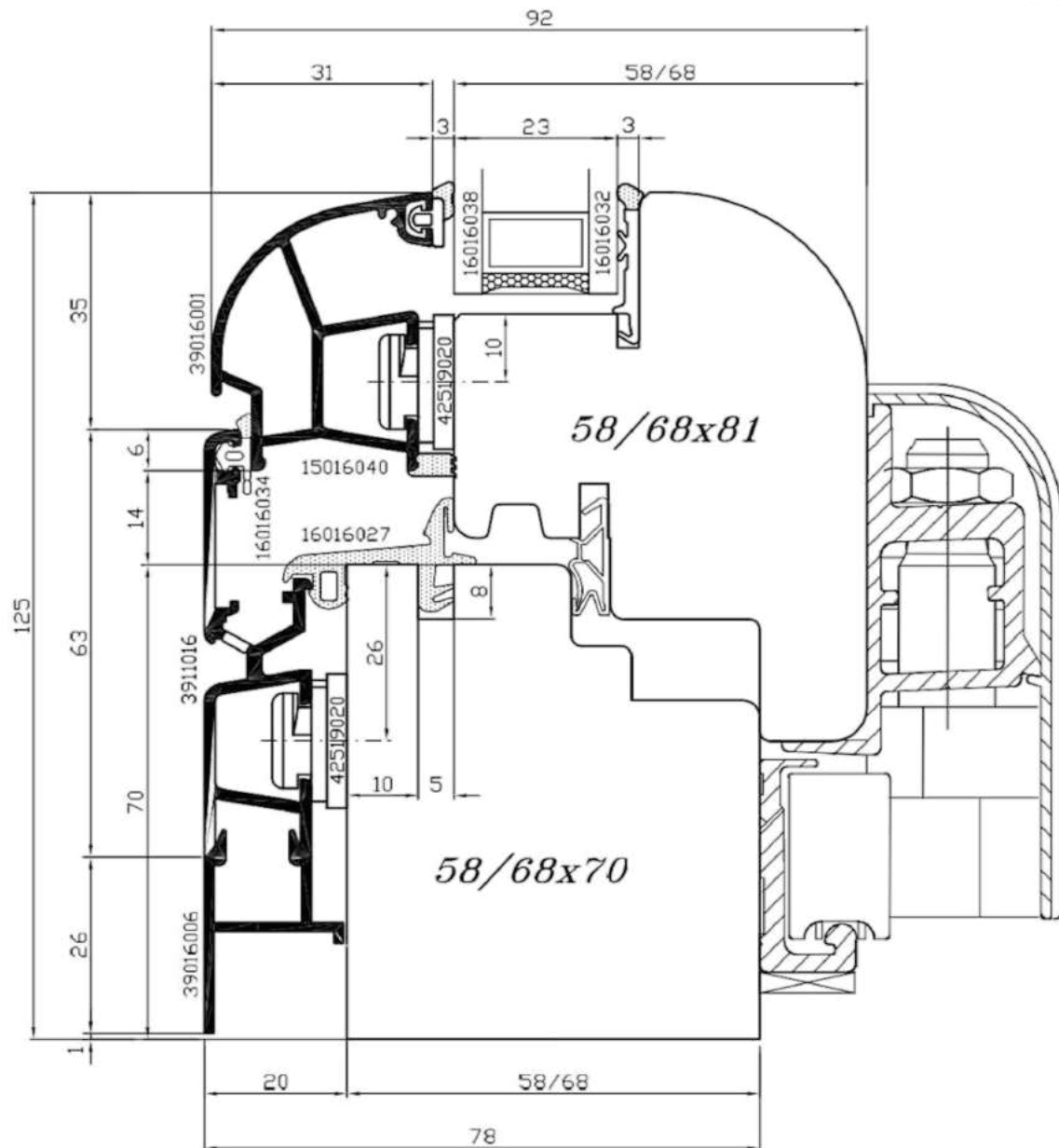

SOLUZIONE STUDIATA SOLO NEL CASO DI ANTA CHE SCORRA SU TELAIO (es. F1A)  
NON DI ANTA CHE SCORRA SU ANTA (es. F2A)

Disegnatore : L.F.	Data Emissione 16/02/2005		File:06s303v5_070402	Sistema <b>ASTRO 6</b>	06S
Approvato da : G.N.	Cliente Standard		REV. 05	Scala Disegno	1:1
Descrizione: <b>SEZIONE VERTICALE TRAVERSO INFERIORE          CON GUIDA BASSA SCORREVOLE PARALLELO</b>				Tolleranze Generali	± 0,5 mm
Mod_35_REV01				PAGINA	<b>303v5</b>

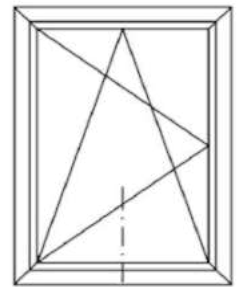

F1A

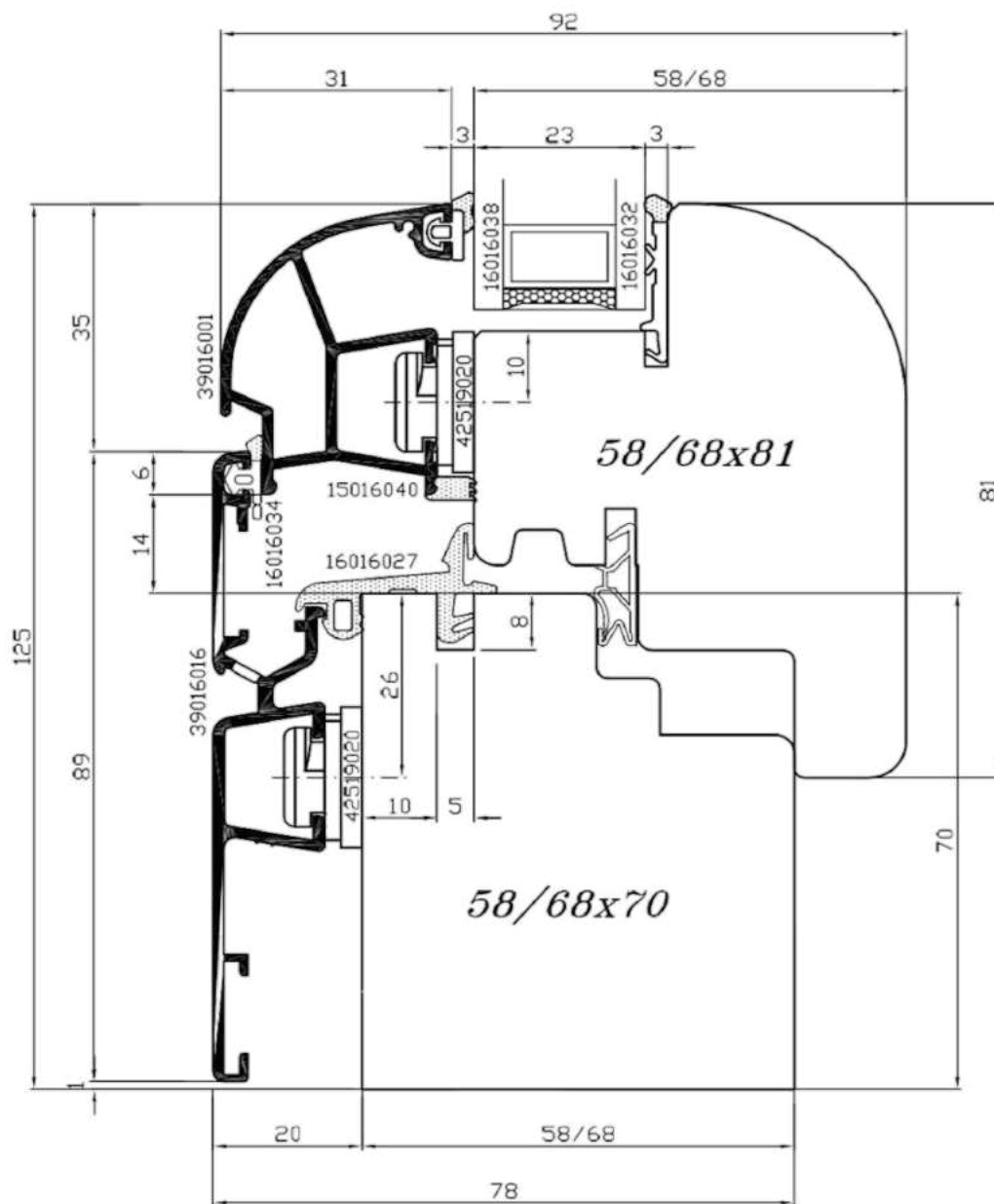

Disegnatore : L.F. Data Emissione 09/02/2006

Approvato da : G.N. Cliente Standard



File:06s303v6\_060209

REV. 04

Sistema **ASTRO 6** 06S

Scala Disegno 1:1

Tolleranze Generali  $\pm 0,5$  mm

Descrizione: **SEZIONE VERTICALE TRAVERSO  
INFERIORE FINESTRA**

PAGINA

**303v6**

Mod\_35\_REV01

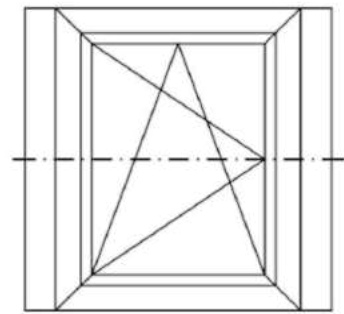

F1A\_gp

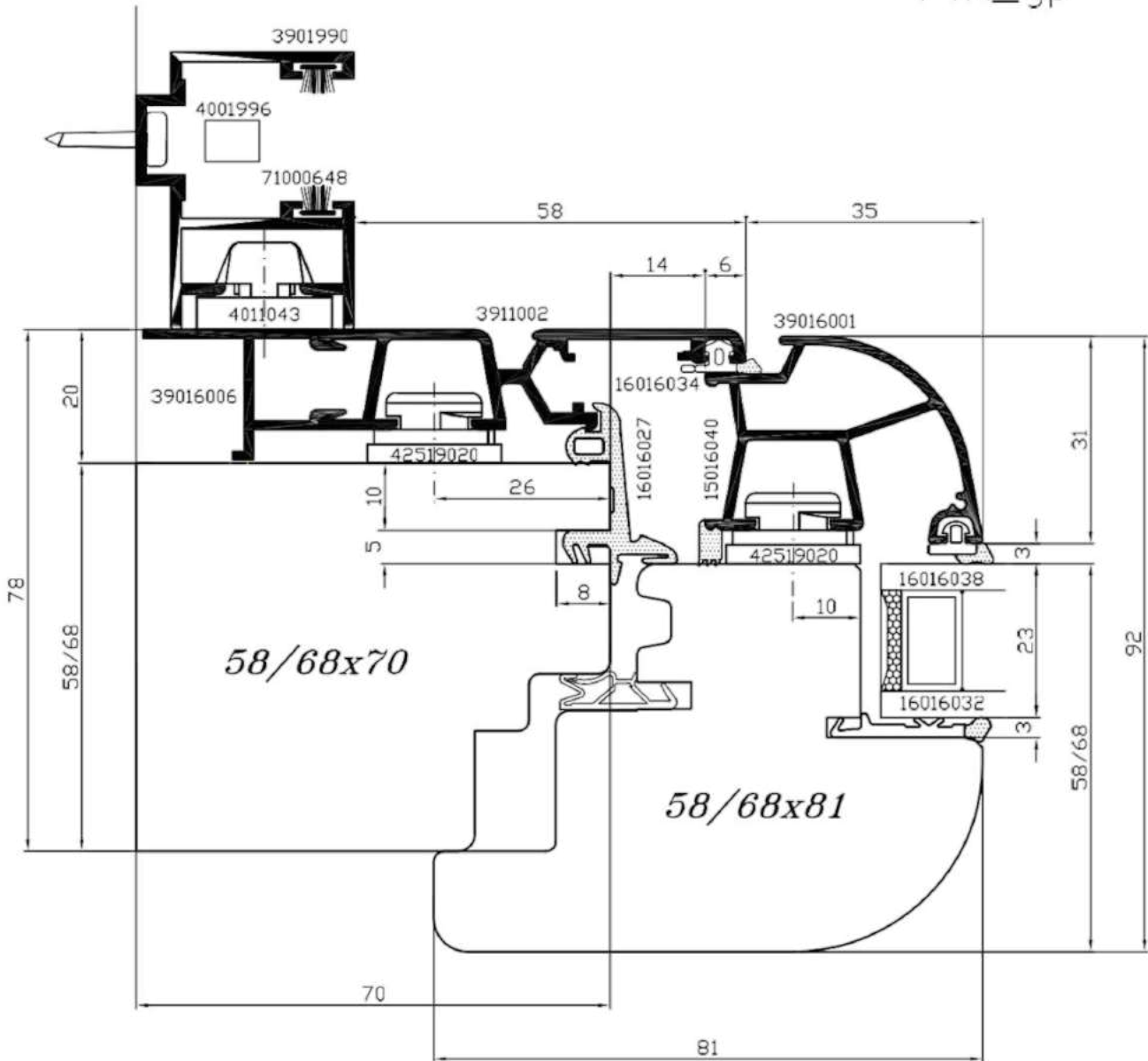

			Sistema <b>ASTRO 6</b>	06S
	Cliente Standard		Scala Disegno	1:1
			Tolleranze Generali	± 0,5mm
Descrizione:	<b>SEZIONE ORIZZONTALE CON GUIDA PERSIANA</b>			PAGINA
Mod_35_REV01				<b>12</b>



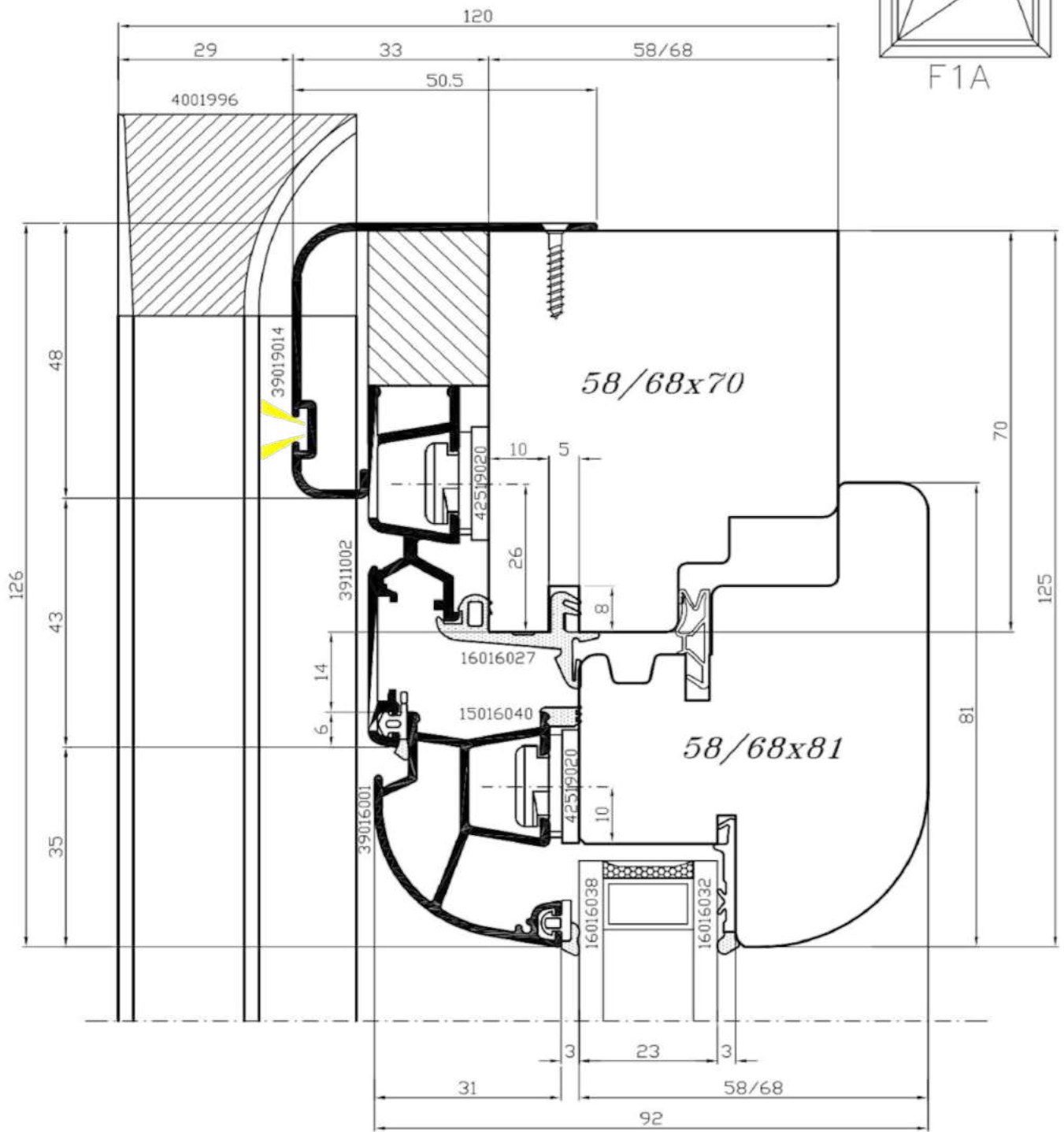
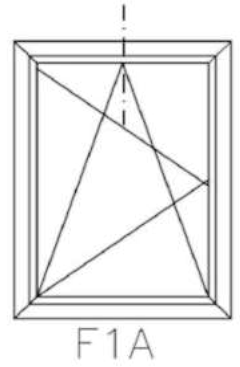

Disegnatore : L.F. Data Emissione 03/03/2007

Approvato da : G.N. Cliente Standard



File:06S9s305\_070303

REV. 00

Sistema **ASTRO 6** 06S

Scala Disegno 1:1

Tolleranze Generali ± 0,5 mm

Descrizione: **SEZIONE VERTICALE TRAVERSO SUPERIORE FINESTRA**

PAGINA

**305**

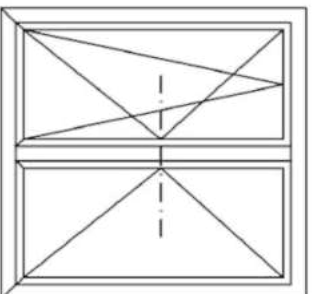
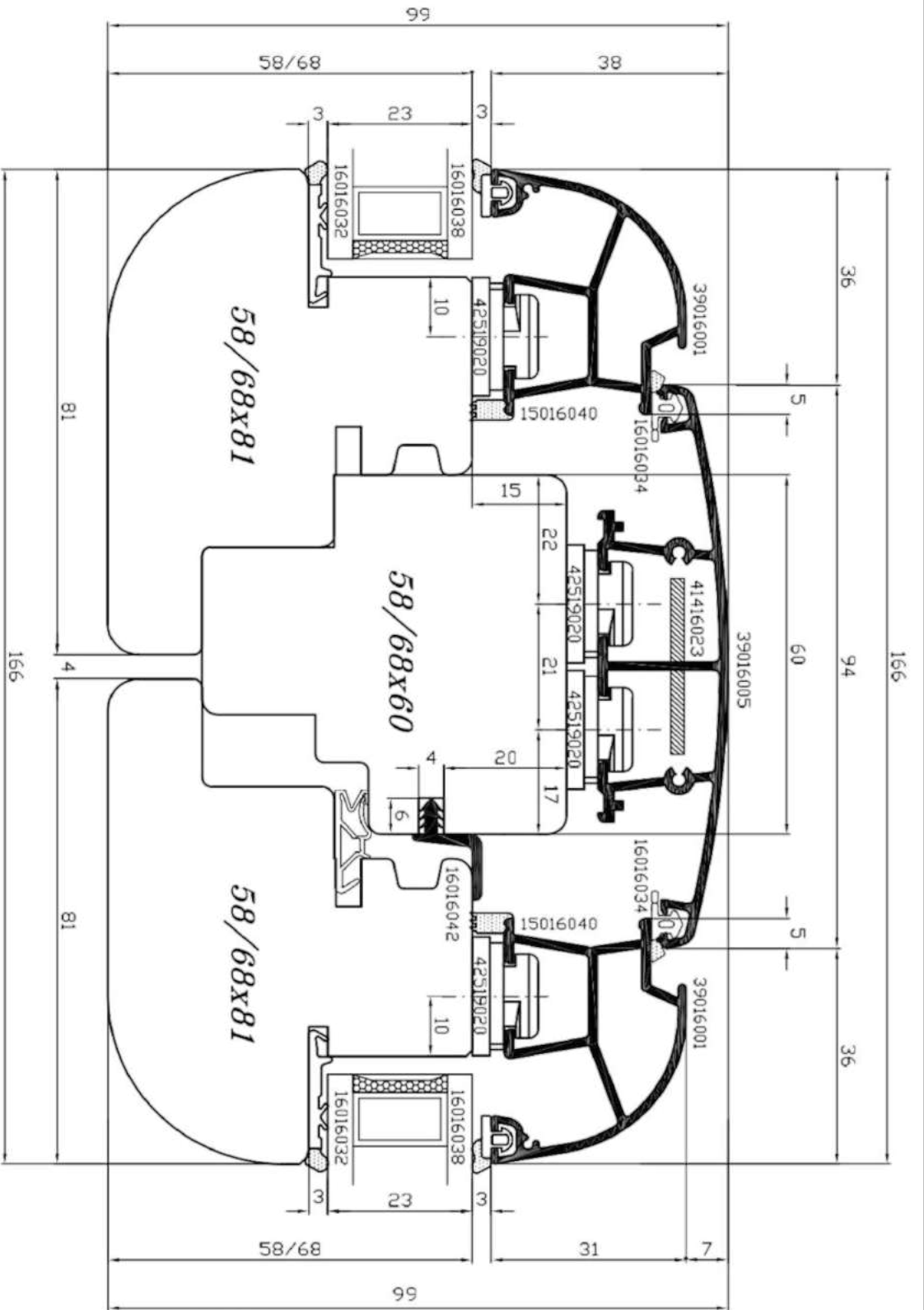

F2A

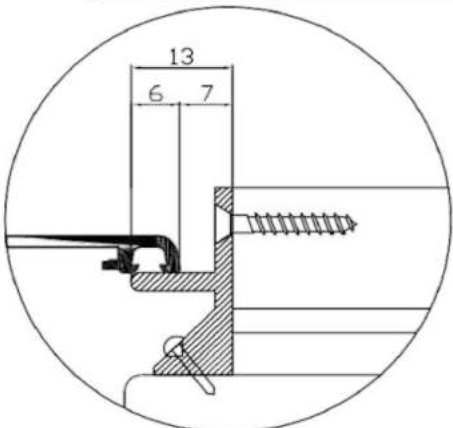

Disegnatore : L.F.	Data Emissione 29/03/2006		File:06s307_060329	Sistema <b>ASTRO 6</b>	06S
Approvato da : G.N.	Cliente Standard		REV. 05	Scala Disegno	1:1
Descrizione: <b>SEZIONE ORIZZONTALE</b> <b>SNODO CENTRALE</b>			Tolleranze Generali	± 0,5 mm	
Mod_35_REV01			PAGINA	<b>307</b>	



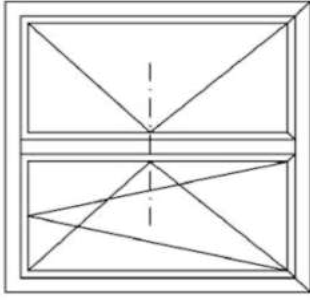

F2A

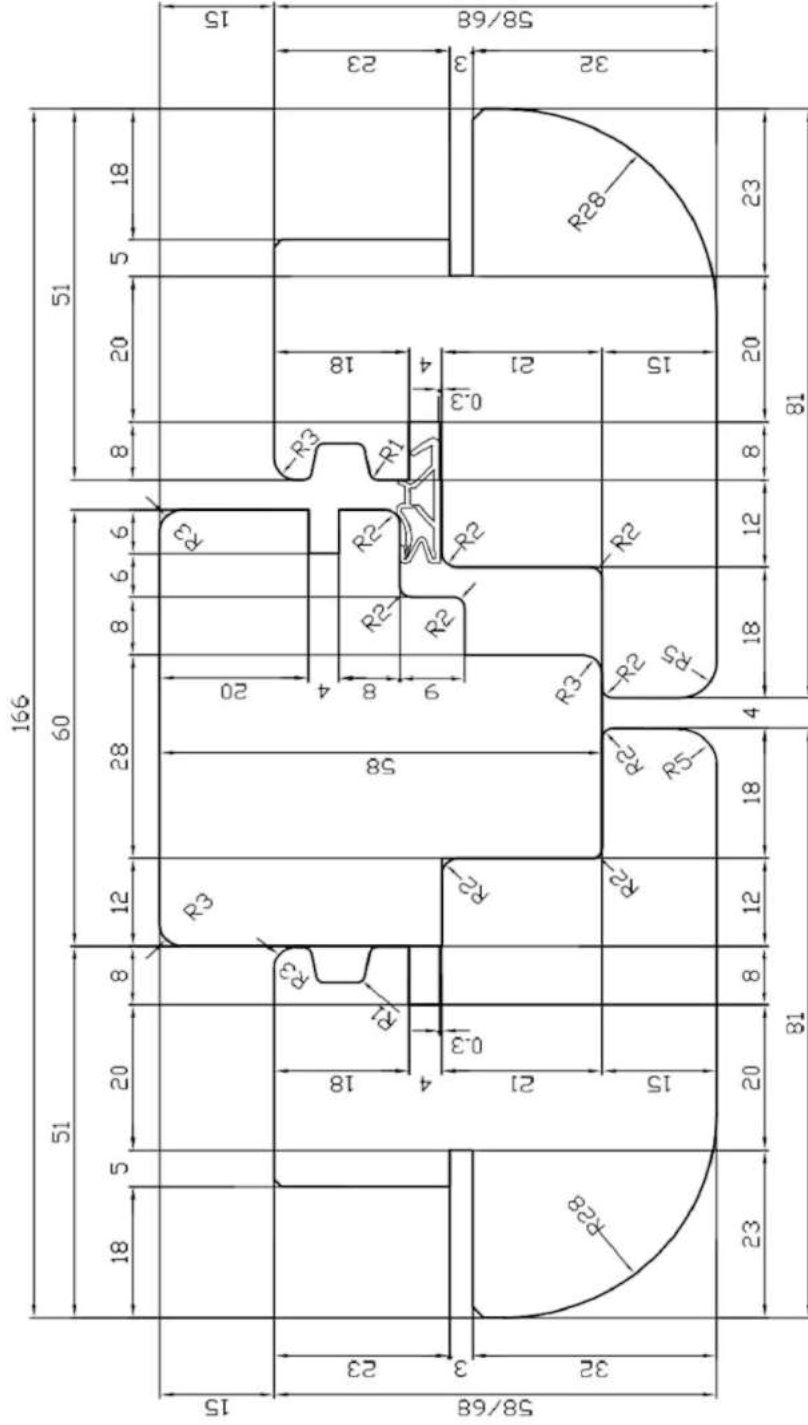

Disegnatore : L.F.	Data Emissione 29/03/2006		File:06s307_060329	Sistema <b>ASTRO 6</b>	06S
Approvato da : G.N.	Cliente Standard		REV. 05	Scala Disegno 1:1	
Descrizione: <b>SEZIONE ORIZZONTALE SNODO CENTRALE</b>			Tolleranze Generali ± 0,5 mm	PAGINA	
Mod_35_REV01			<b>307L</b>		

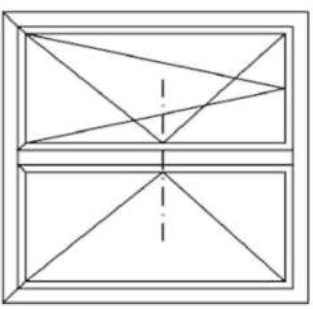
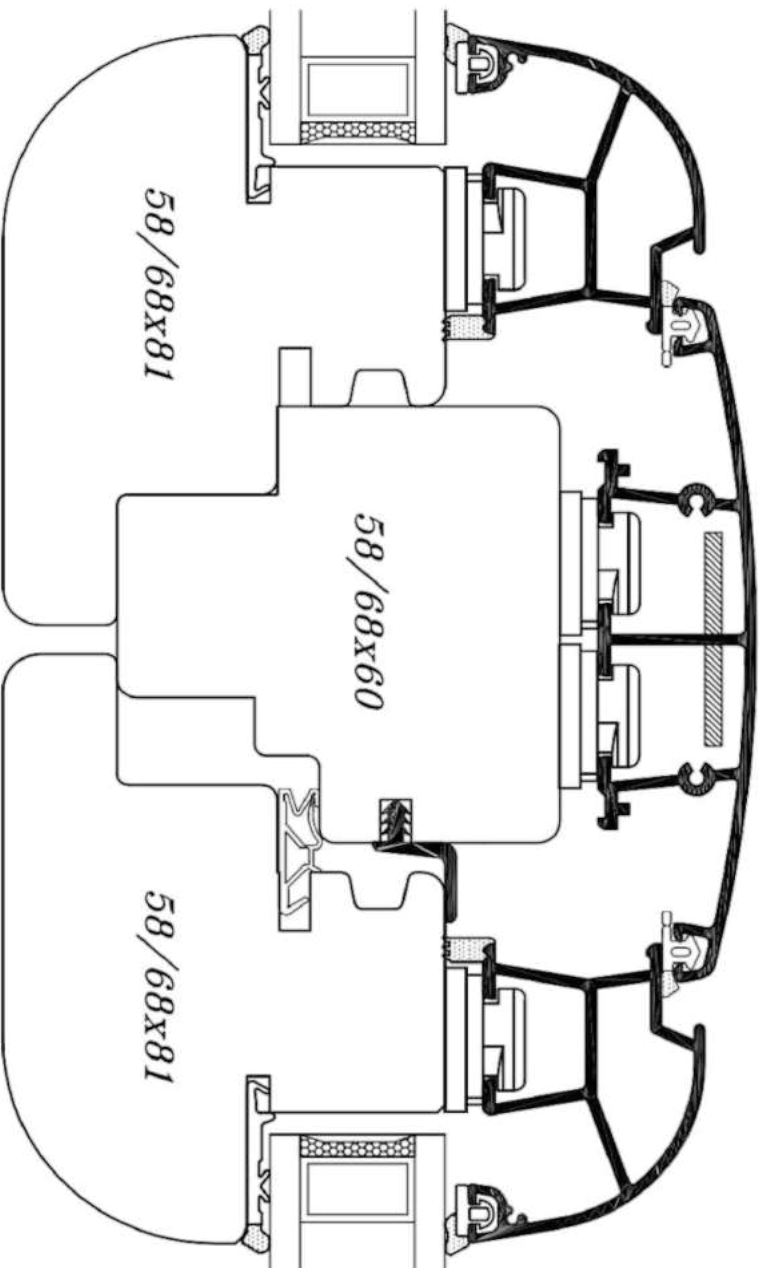

F2A

MONTANTINO  
CENTRALE  
CDD.39016005

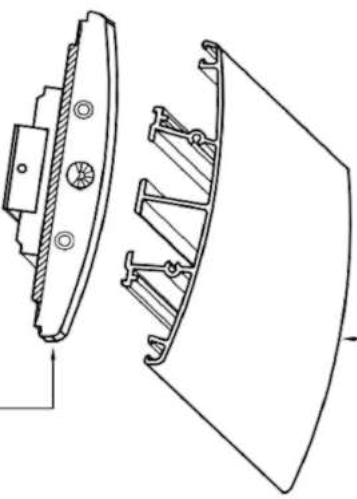

TERMINALE 41416023

Disegnatore : L.F.	Data Emissione 29/03/2006
Approvato da : G.N.	Cliente Standard



File:06s307\_060329  
REV. 05

Descrizione:

**MOTAGGIO DEL TERMINALE**  
**COD.41416023**

Sistema <b>ASTRO 6</b>	06S
Scala Disegno 1:1-Fuori Scala	
Tolleranze Generali ± 0,5 mm	

PAGINA

**307m**

Mod\_35\_REV01

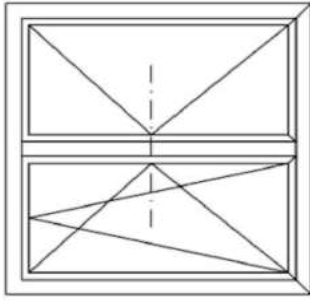

F2A

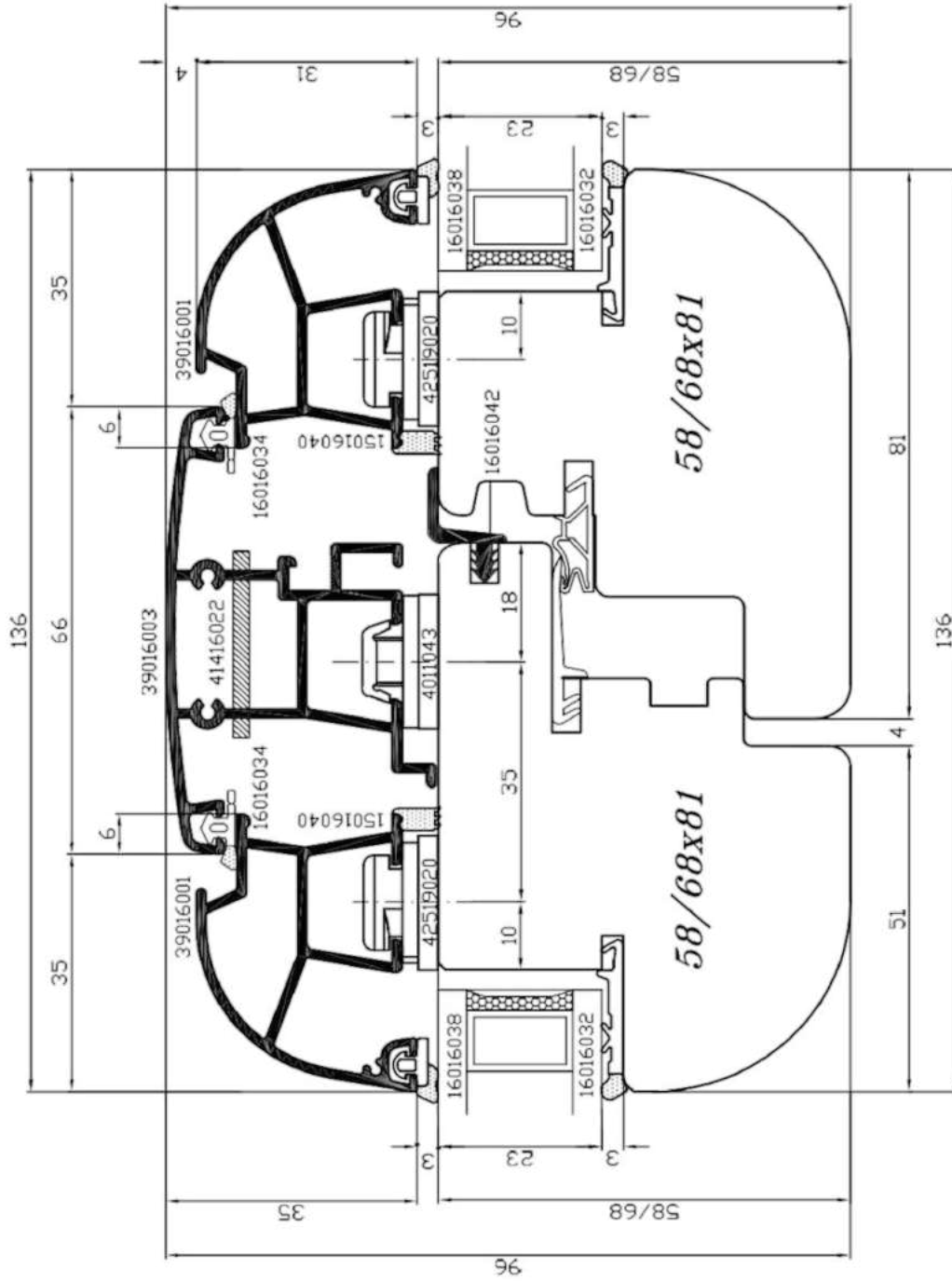
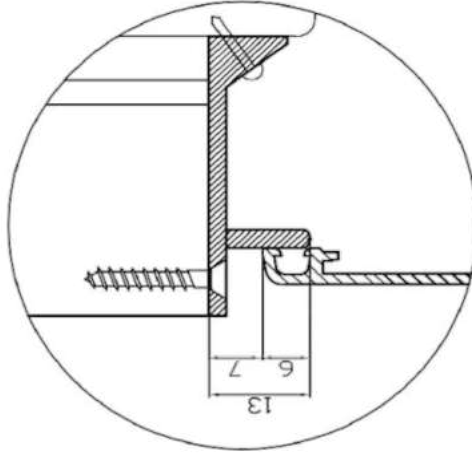

Disegnatore : L.F. Data Emissione 16/02/2005

Approvato da : G.N. Cliente Standard

Descrizione:

**SEZIONE ORIZZONTALE  
SNODO CENTRALE**

Mod\_35\_REV01

File:06s307v1\_050216

REV. 04

Sistema **ASTRO 6** 06S

Scala Disegno 1:1

Tolleranze Generali ± 0,5 mm

PAGINA

**307v1**

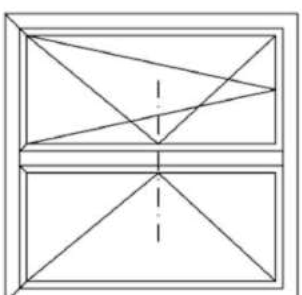

F2A

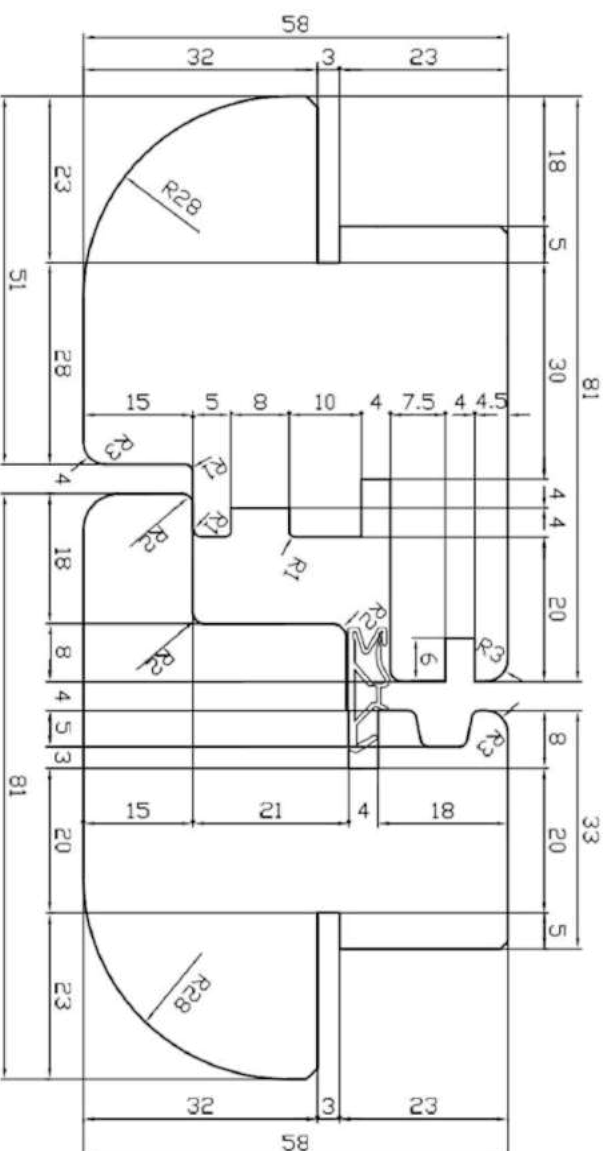

Disegnatore :	L.F.	Data Emissione	16/02/2005
Approvato da :	G.N.	Cliente	Standard
		File:	06s307v1_050216
		REV.	04

Descrizione:

**SEZIONE ORIZZONTALE  
SNODO CENTRALE**

Mod\_35\_REV01

Sistema	<b>ASTRO 6</b>	065
Scala Disegno		1:1
Tolleranze Generali	± 0,5 mm	

PAGINA

**307V1L**

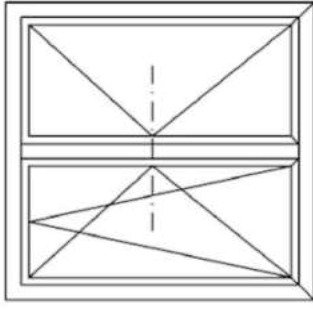

F2A

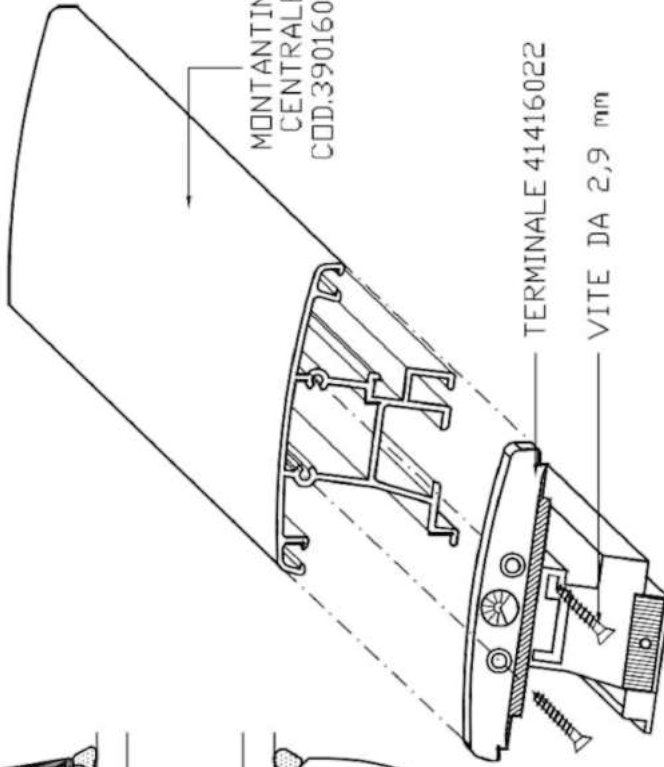
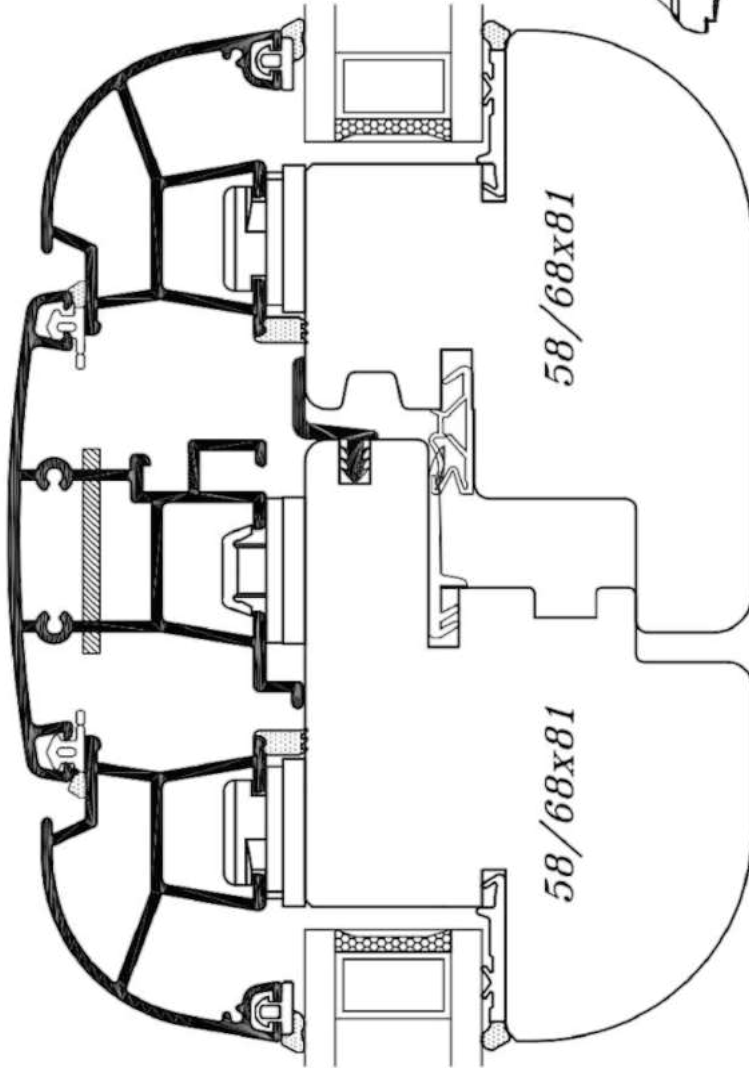

Disegnatore : L.F.	Data Emissione 16/02/2005		File:06s307v1m_050216	Sistema <b>ASTRO 6</b>	06:
Approvato da : G.N.	Cliente Standard		REV. 04	Scala Disegno 1:1 - Fuori Scal	
Descrizione: <b>MONTAGGIO DEL TERMINALE</b> <b>COD. 41416022</b>		Tolleranze Generali ± 0,5 mm PAGINA		<b>307v1m</b>	
Mod_35_REV01					



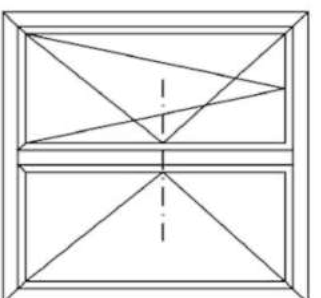
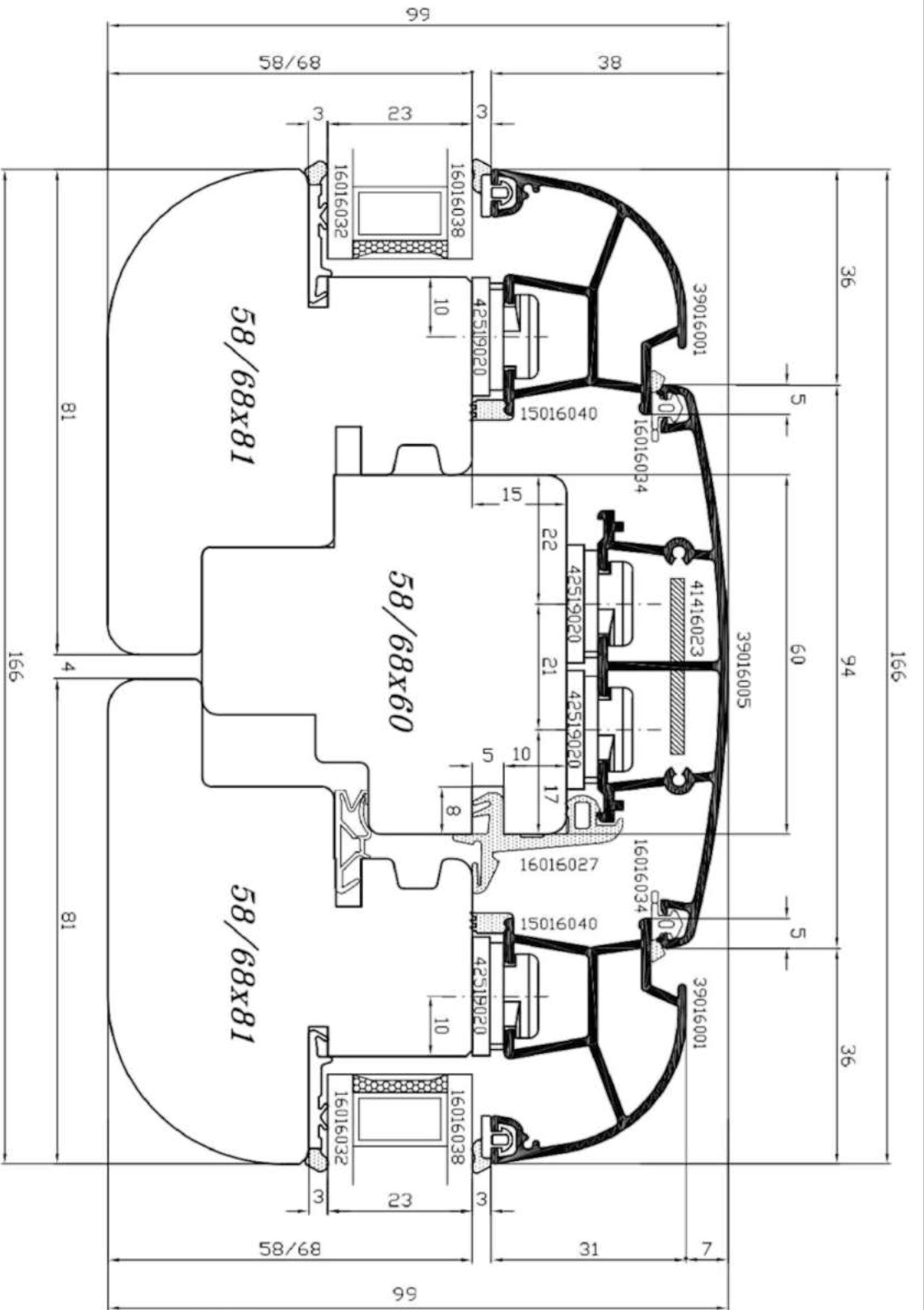

F2A

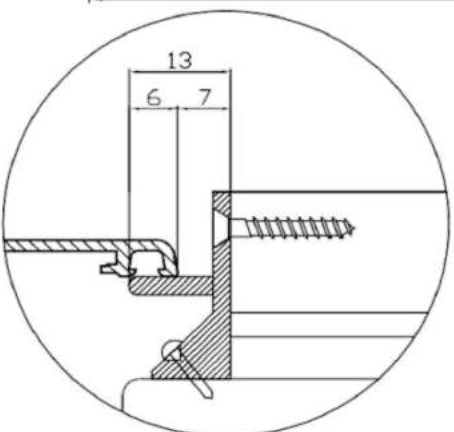

Disegnatore : L.F.	Data Emissione 29/03/2006		File:06s307v2_060329	Sistema <b>ASTRO 6</b>	06S
Approvato da : G.N.	Cliente Standard		REV. 05	Scala Disegno	1:1
Descrizione: <b>SEZIONE ORIZZONTALE</b> <b>SNODO CENTRALE</b>			Tolleranze Generali	± 0,5 mm	
Mod_35_REV01			PAGINA <b>307V2</b>		

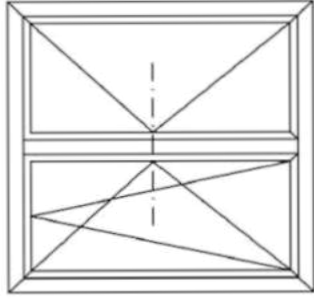

F2A

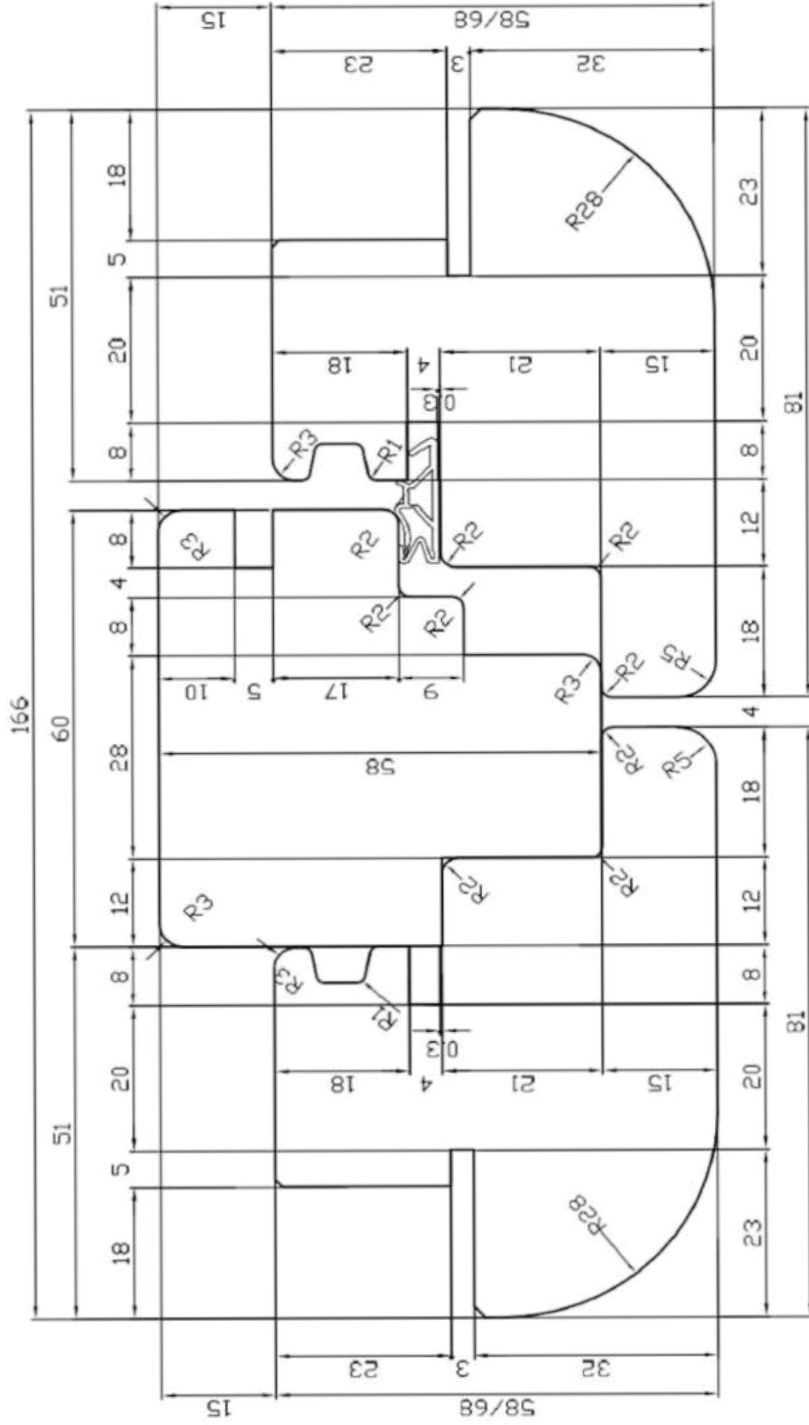

Disegnatore : L.F.	Data Emissione 29/03/2006		File:06s307v2_060329	Sistema <b>ASTRO 6</b>	06S
Approvato da : G.N.	Cliente Standard		REV. 05	Scala Disegno 1:1	
Descrizione: <b>SEZIONE ORIZZONTALE SNODO CENTRALE</b>				Tolleranze Generali ± 0,5 mm	
Mod_35_REV01				PAGINA	<b>307v2L</b>

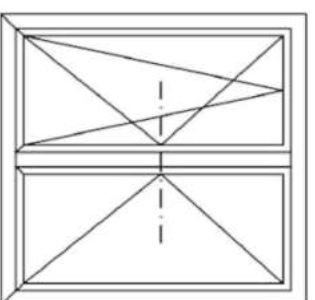
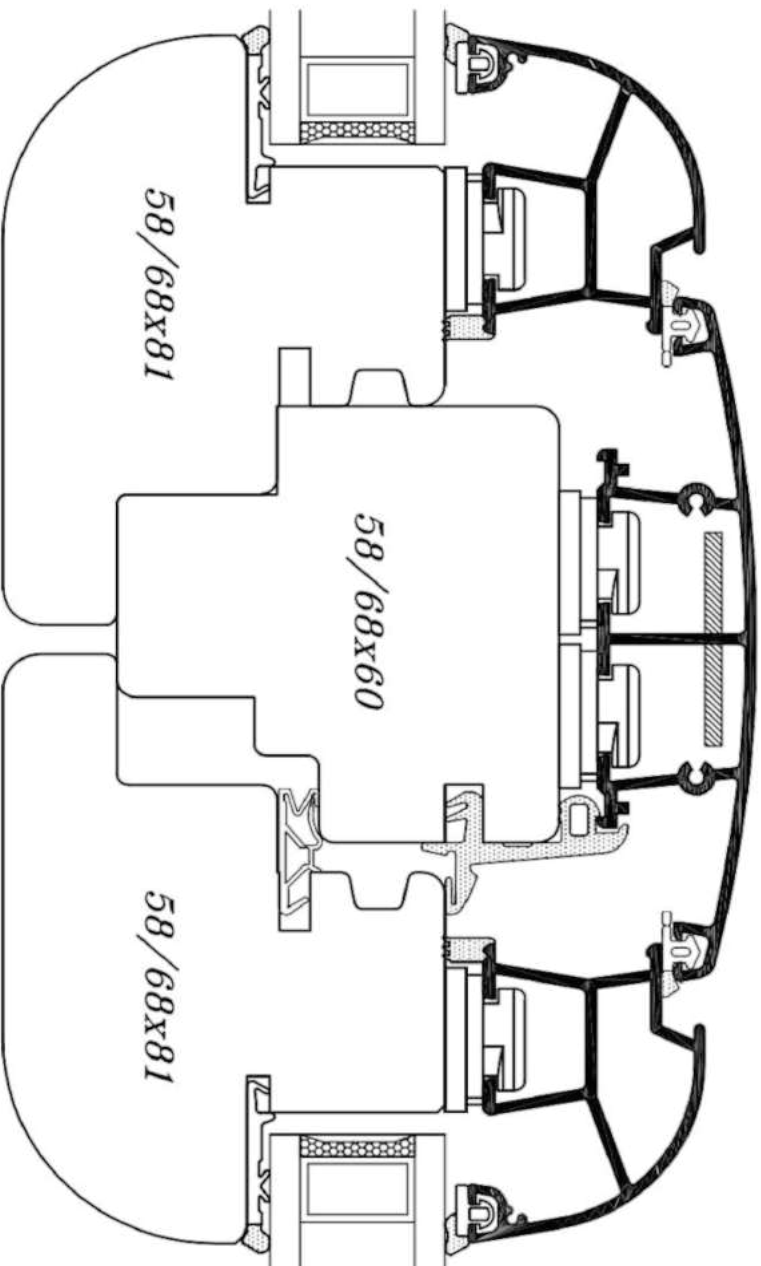

F2A

MONTANTINO  
CENTRALE  
CDD.39016005

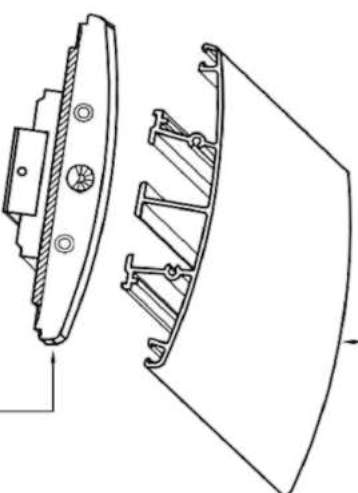

TERMINALE 41416023

Disegnatore :	L.F.	Data Emissione	29/03/2006
Approvato da :	G.N.	Cliente	Standard



File:06s307v2m\_060329  
REV. 05

Sistema **ASTRO 6** 06S

Scala Disegno 1:1-Fuori Scala

Tolleranze Generali ± 0,5 mm

Descrizione:

**MOTAGGIO DEL TERMINALE**  
**COD.41416023**

PAGINA

**307v2m**

Mod\_35\_REV01



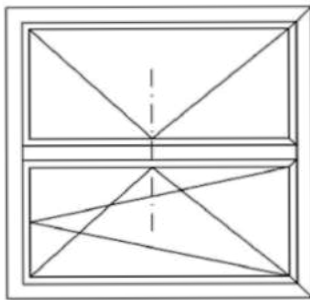

F2A

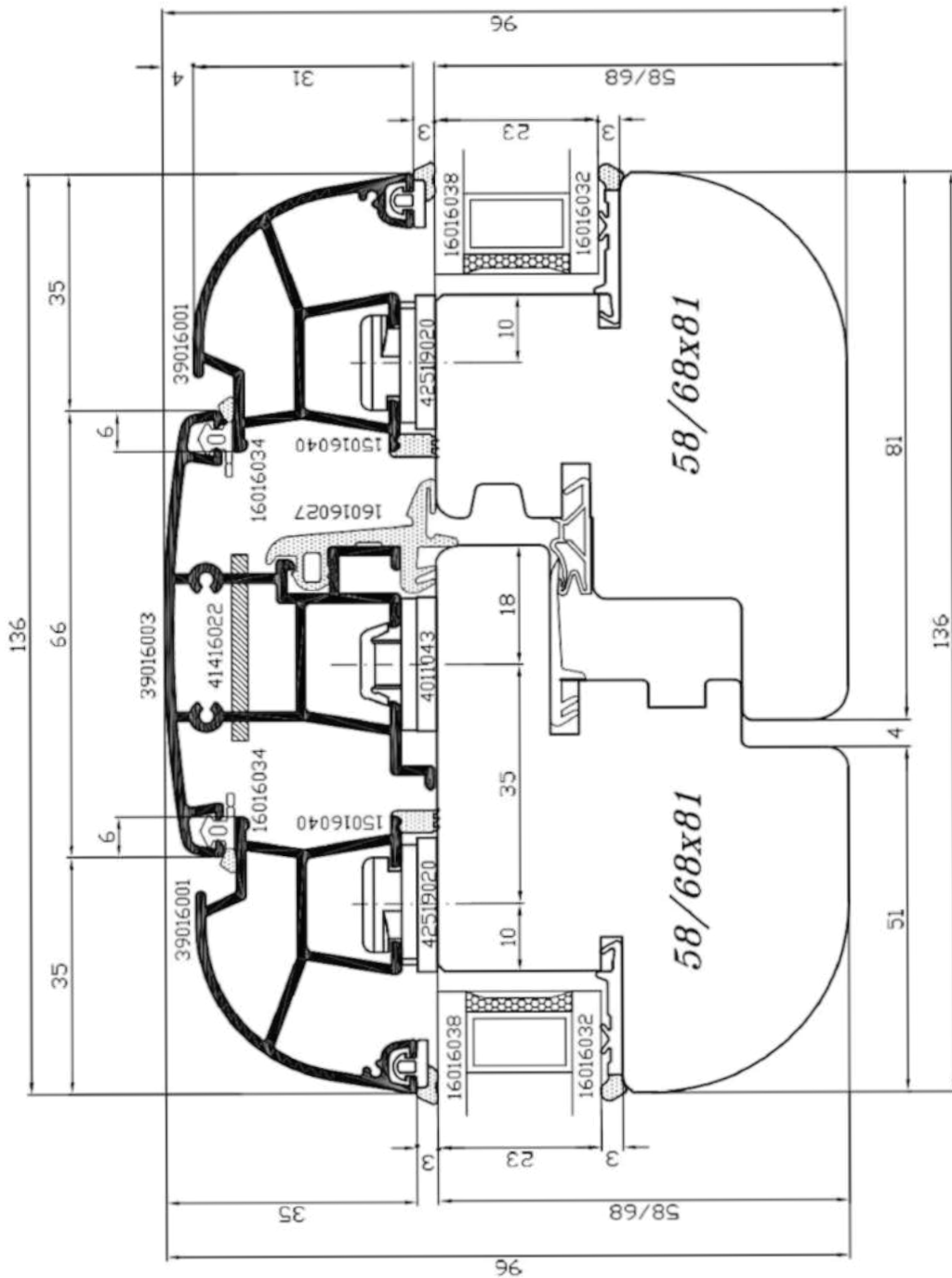
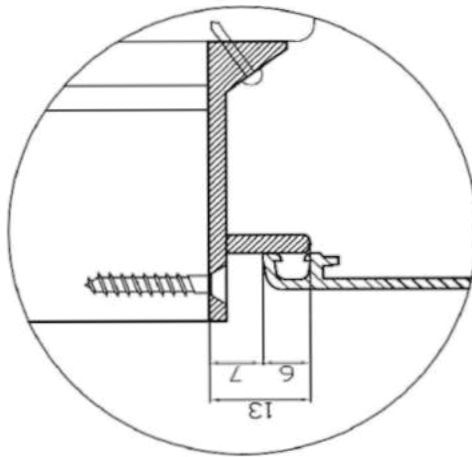

Disegnatore : L.F. Data Emissione 29/03/2006

Approvato da : G.N. Cliente Standard

Descrizione:

**SEZIONE ORIZZONTALE  
SNODO CENTRALE**

Mod\_35\_REV01

File:06s307v4\_060329

REV. 05

Sistema **ASTRO 6** 06S

Scala Disegno 1:1

Tolleranze Generali ± 0,5 mm

PAGINA

**307v4**

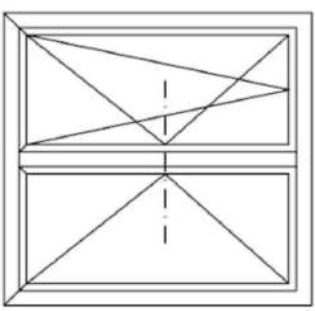

F2A

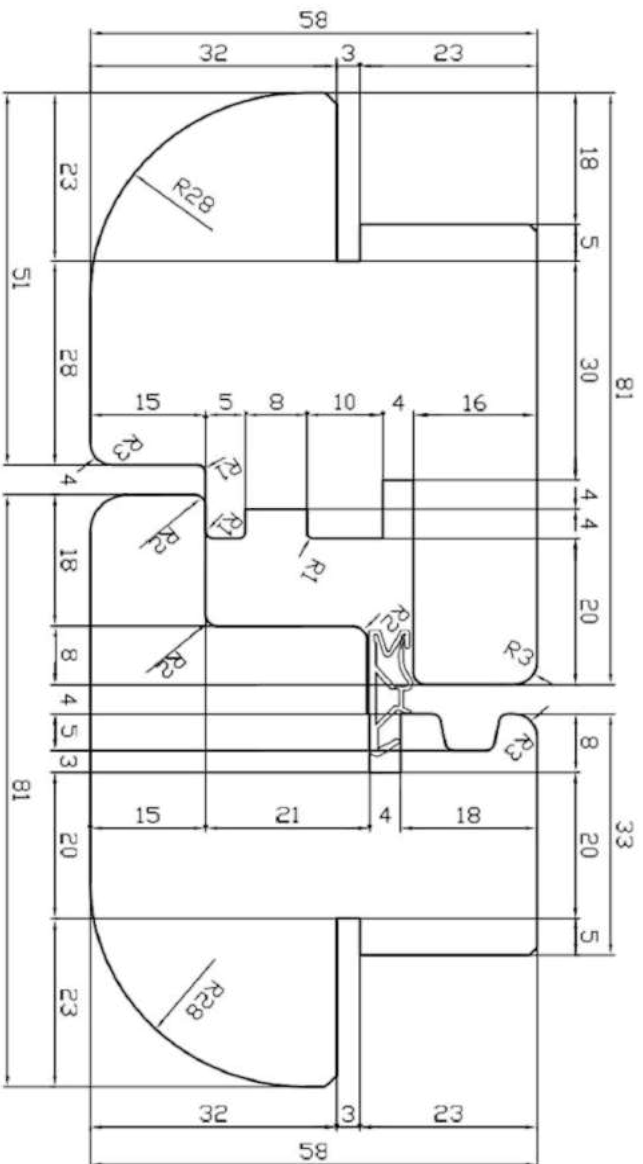

Disegnatore : L.F.	Data Emissione 29/03/2006		File:06s307v4_060329	Sistema <b>ASTRO 6</b>	06S
Approvato da : G.N.	Cliente Standard		REV. 05	Scala Disegno 1:1	Tolleranze Generali ± 0,5 mm
Descrizione: <b>SEZIONE ORIZZONTALE SNODO CENTRALE</b>			PAGINA	<b>307v4L</b>	
Mod. 35_REV01					

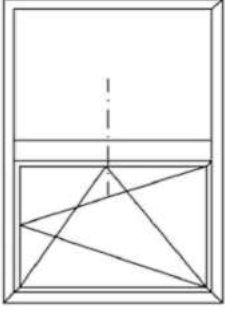

F2A\_cma

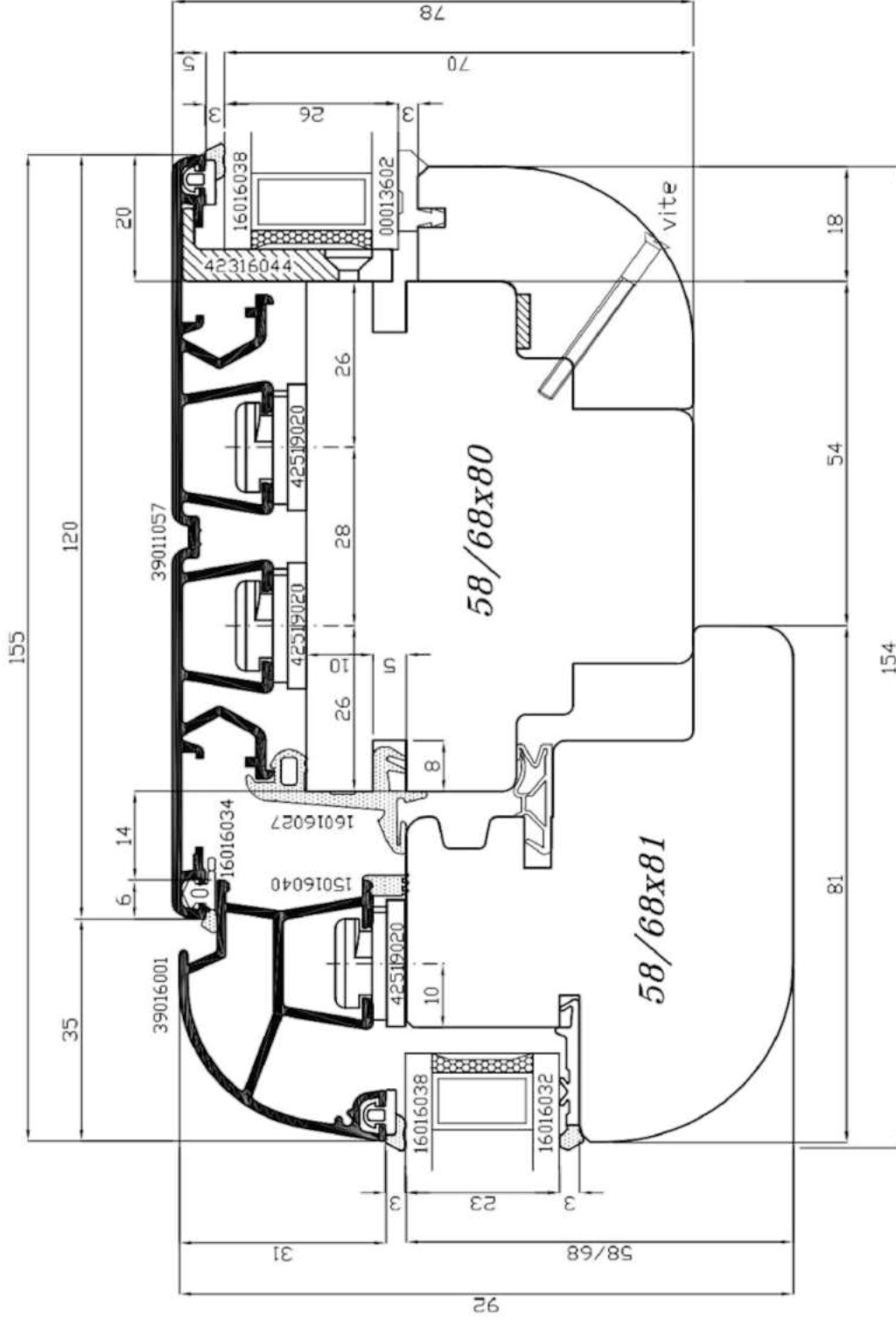

Disegnatore :	L.F.	Data Emissione 10/06/2005	File:06s311_050610	Sistema <b>ASTRO 6</b>	06S
Approvato da :	G.N.	Cliente Standard	REV. 05	Scala Disegno	1:1
Descrizione: <b>SEZIONE ORIZZONTALE MONTANTE FINESTRA APRIBILE-FISSO</b>			Tolleranze Generali ± 0,5mm		
Mod_35_REV01			PAGINA		

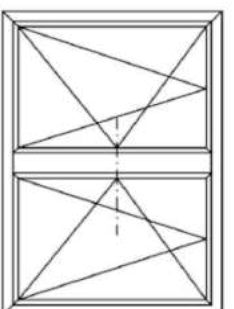

F2A\_cmt

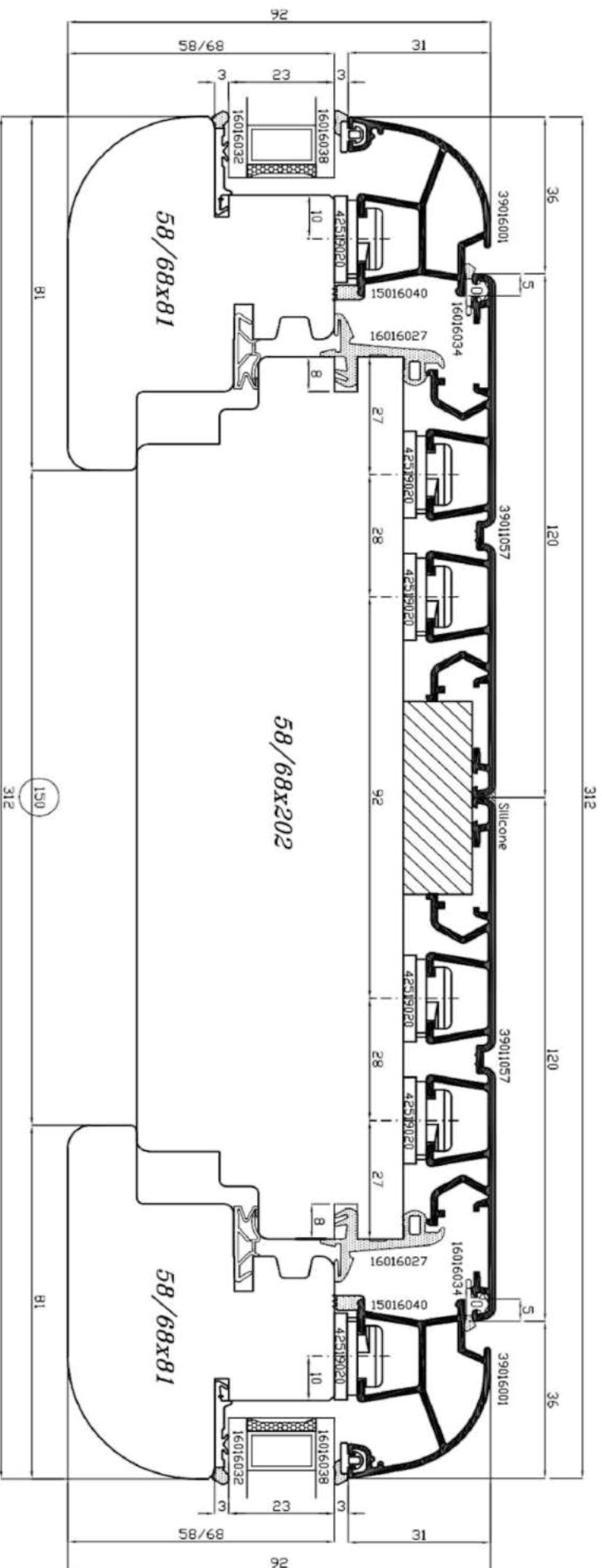

Disegnatore :	L.F.	Data Emisione	10/07/2008
Cliente	Standard		



File:	06s311v2_050926
REV.	00

Sistema	ASTRO 6	06S
Scalo Disegno		1:1
Tolleranze Generali	± 0,5mm	

Descrizione: **SEZIONE ORIZZONTALE MONTANTE**  
**FISSO SU TELAIO**

Mod\_35\_REV01

PAGINA  
**311v12**





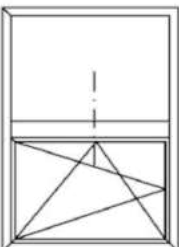
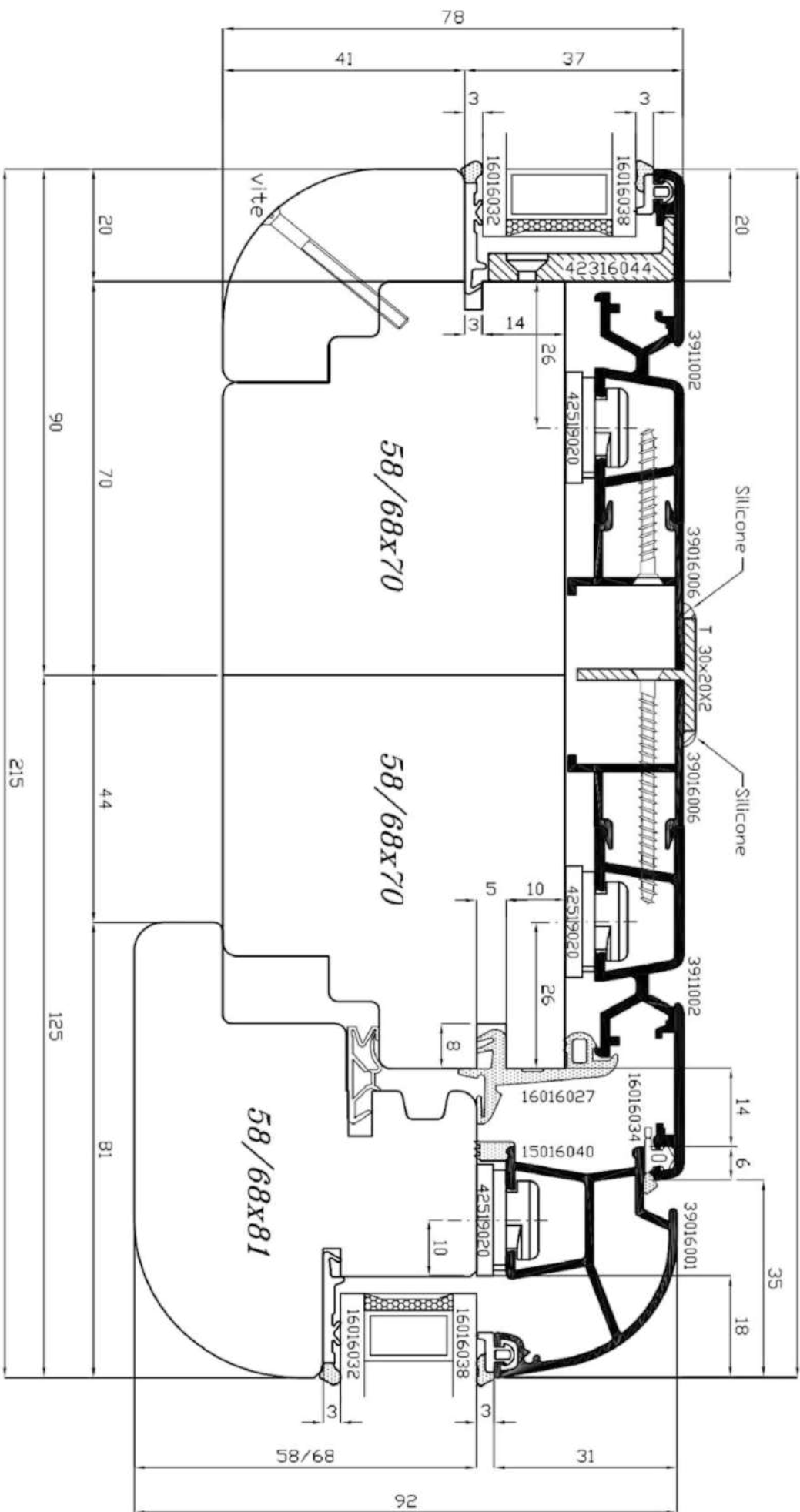

F2A\_mt

Attenzioni: finestra fissa.  
 Fissare con vite su telaio  
 l'accessorio cod.42316044  
 come supportoper il profilo  
 39016002 con interasse 150mm

Disegnatore :	L.F.	Data Emissione	13/04/2006
Approvato da :	G.N.	Cliente	Standard



File:	06s311v5_060413
REV.	00

Descrizione: **SEZIONE ORIZZONTALE MONTANTE  
 FINESTRA FISSO-APRIBILE**

Sistema	<b>ASTRO 6</b>	06S
Scala Disegno		1:1
Tolleranze Generali		± 0,5mm

PAGINA

311v5



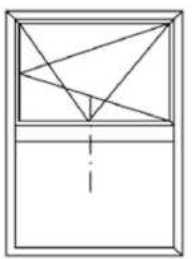
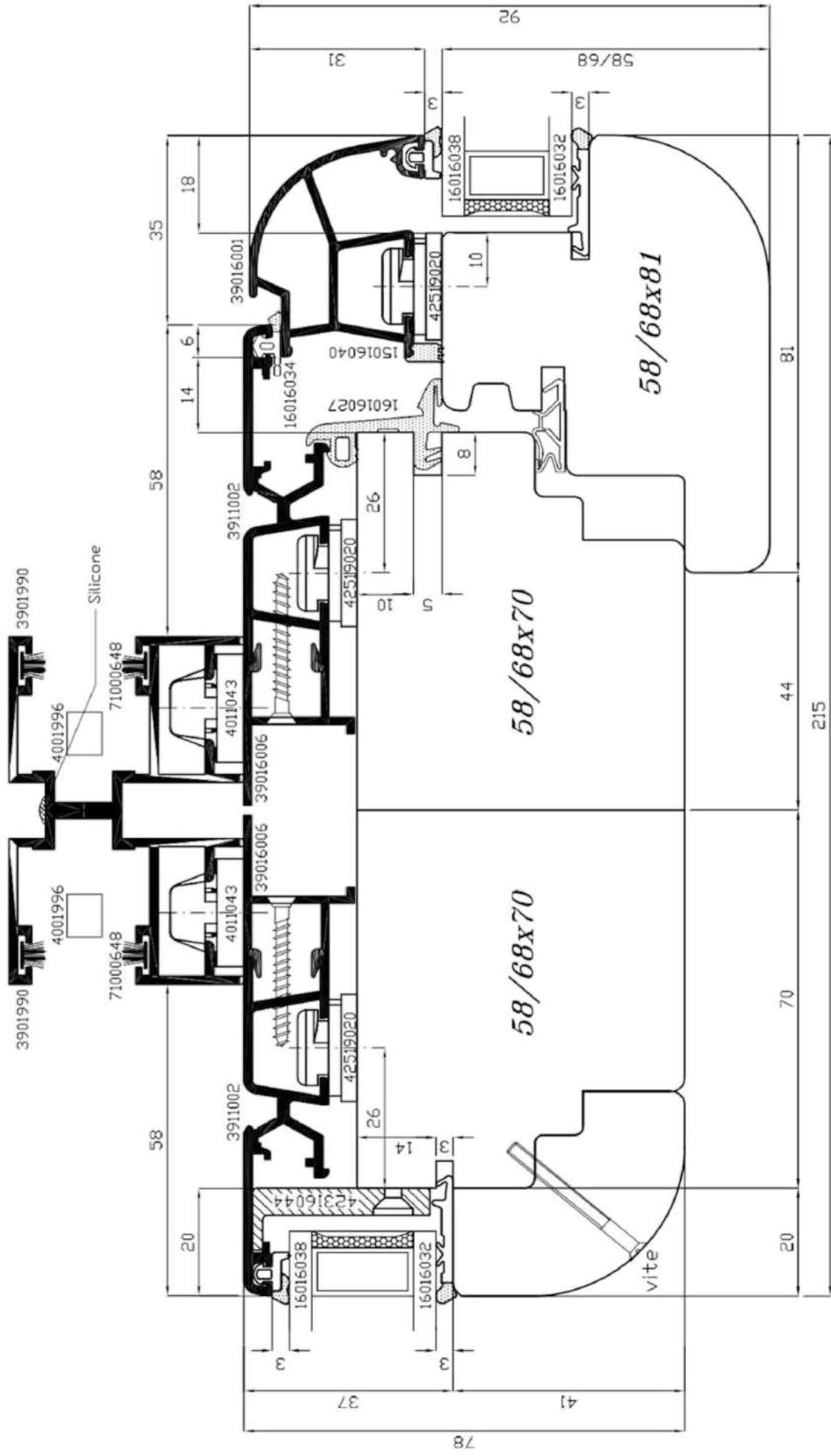

F2A\_mt

Attenzione: finestra fissa.  
 Fissare con vite su telaio  
 l'accessorio cod.42316044  
 come supporter il profilo  
 39016002 con interasse 150mm

Disegnatore : L.F. Data Emissione 13/04/2006

Approvato da : G.N. Cliente Standard



File:06s311v6\_060413

REV. 00

Sistema **ASTRO 6** 06S

Scala Disegno 1:1

Tolleranze Generali ± 0,5mm

Descrizione: **SEZIONE ORIZZONTALE MONTANTE  
 FINESTRA FISSO-APRIBILE**

**311V6**

Mod\_35\_REV01

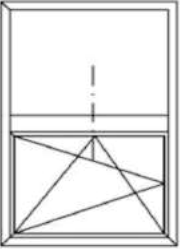
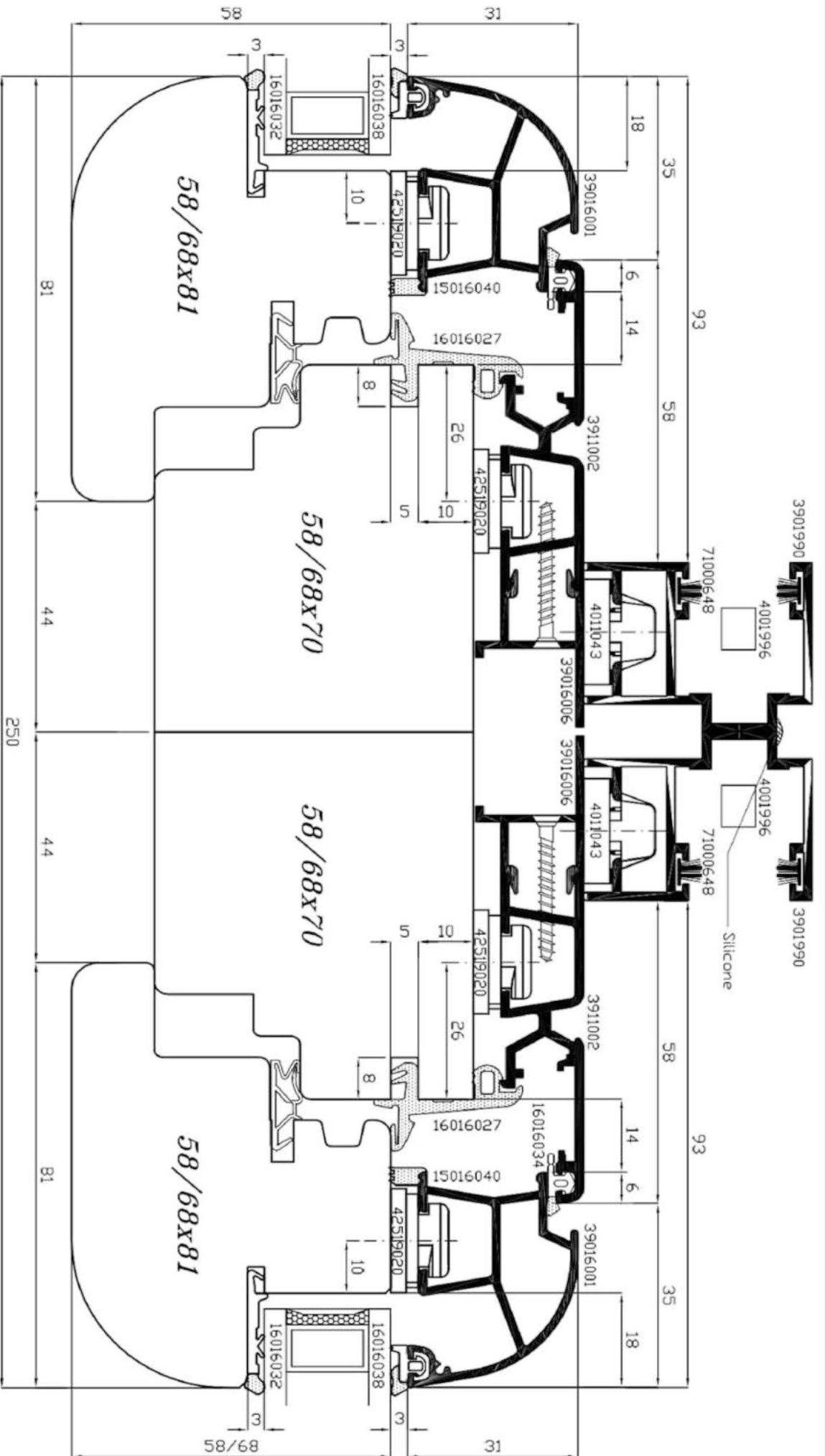

F2A\_mt

Attenzioni: finestra fissa.  
 Fissare con vite su telaio  
 l'accessorio cod.42316044  
 come supportoper il profilo  
 39016002 con interasse 150mm

Disegnatore :	L.F.	Data Emissione	13/04/2006		File:	06s311v7_060413
Approvato da :	G.N.	Cliente	Standard		REV.	00
Descrizione: <b>SEZIONE ORIZZONTALE MONTANTE          FINESTRA FISSO-APRIBILE</b>				Sistema <b>ASTRO 6</b> 06S Scala Disegno 1:1 Tolleranze Generali ± 0,5mm PAGINA		
Mod. 35_RR01				<b>311v7</b>		

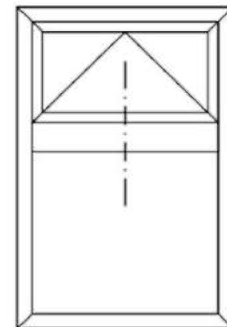
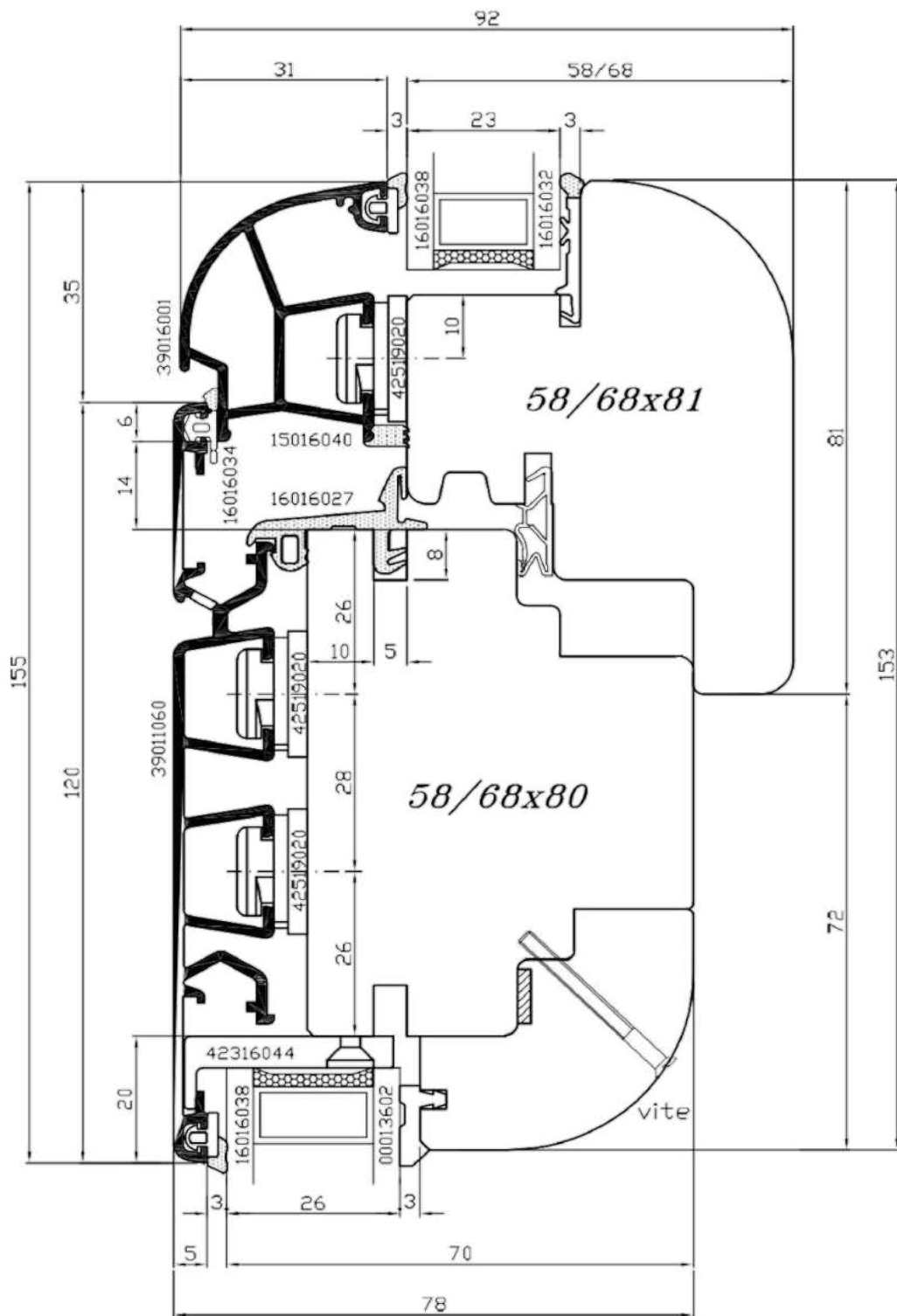

F1A\_sta

			Sistema <b>ASTRO 6</b> 06S
Cliente Standard			Scala Disegno 1:1
			Tolleranze Generali ± 0,5mm
Descrizione: <b>SEZIONE VERTICALE TRAVERSO FINESTRA SOPRALUCE APRIBILE</b>			PAGINA
Mod_35_REV01			

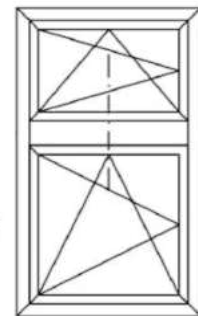
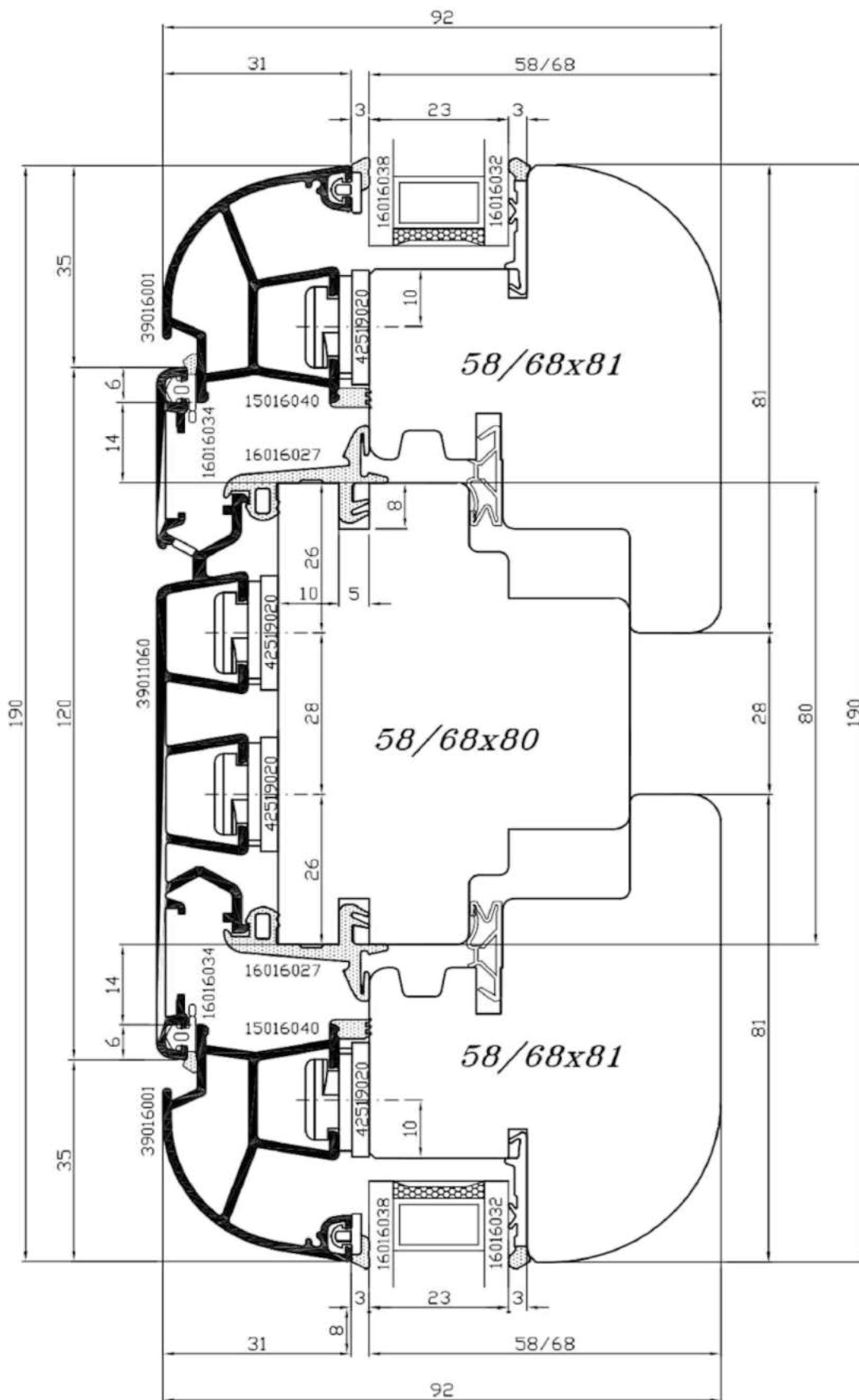

PF2A\_sta

Disegnatore : L.F. Data Emissione 01/04/2005

Approvato da : G.N. Cliente Standard



File:06s313v2\_050401

REV. 04

Sistema **ASTRO 6** 06S

Scala Disegno 1:1

Tolleranze Generali ± 0,5mm

Descrizione: **SEZIONE VERTICALE TRAVERSO  
PORTAFINESTRA APRIBILE-APRIBILE**

PAGINA

**313v2**

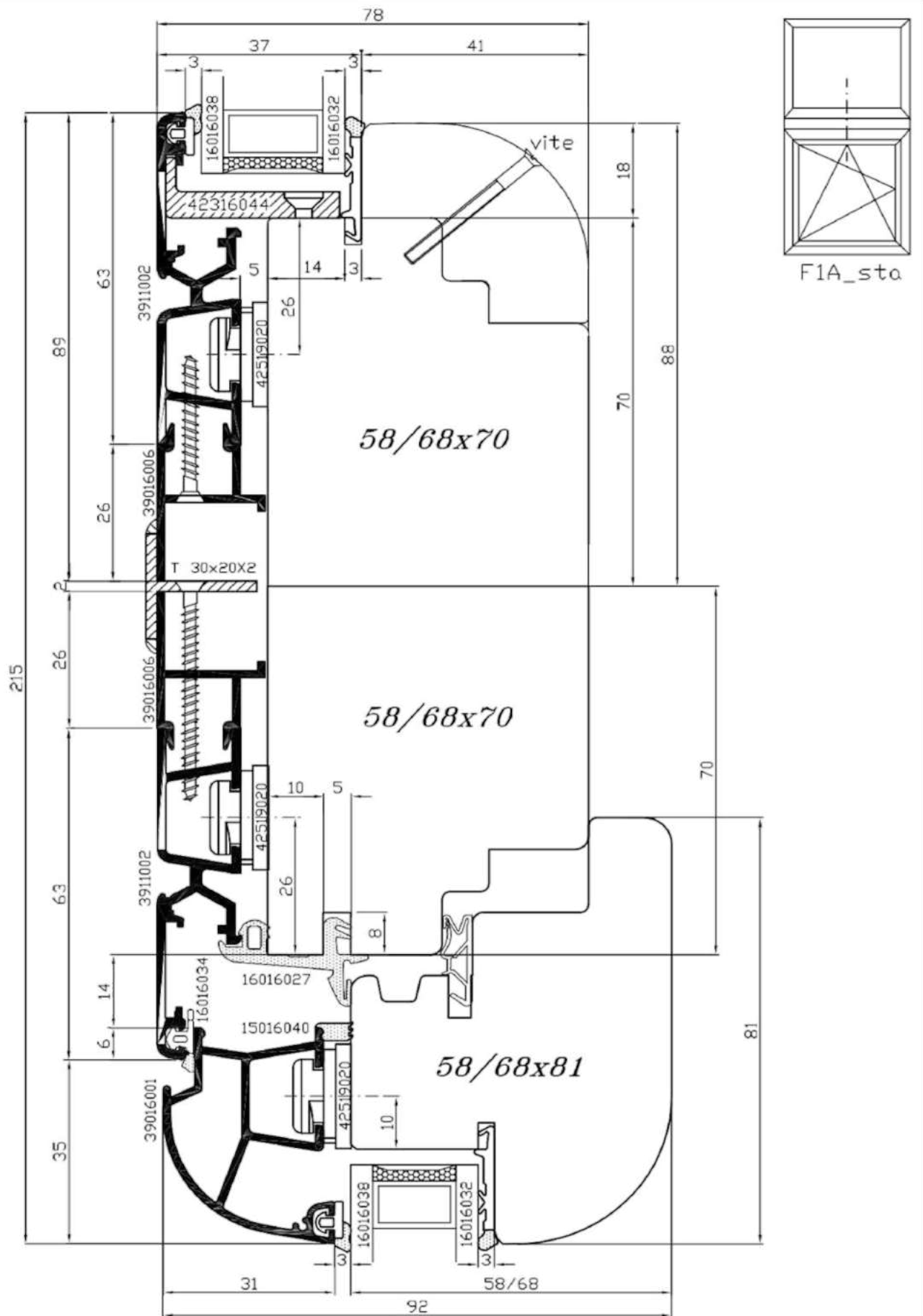

Disegnatore : L.F. Data Emissione 13/04/2006

Approvato da : G.N. Cliente Standard



File:06s314v4\_060413

REV. 00

Sistema Astro 6 06S

Scala Disegno 1:1

Tolleranze Generali ± 0,5mm

Descrizione: **SEZIONE VERTICALE TRAVERSO  
CON SOTTOLUCE APRIBILE**

PAGINA

**314v4**



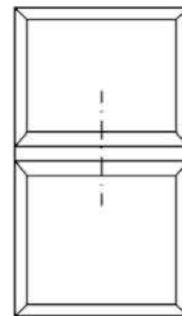

F1A\_sta

			Sistema Astro 6	06S
	Cliente Standard		Scala Disegno	1:1
			Tolleranze Generali	± 0,5mm
Descrizione: <b>SEZIONE VERTICALE TRAVERSO CON SOTTOLUCE APRIBILE</b>			PAGINA <b>314v5</b>	
Mod_35_REV01				



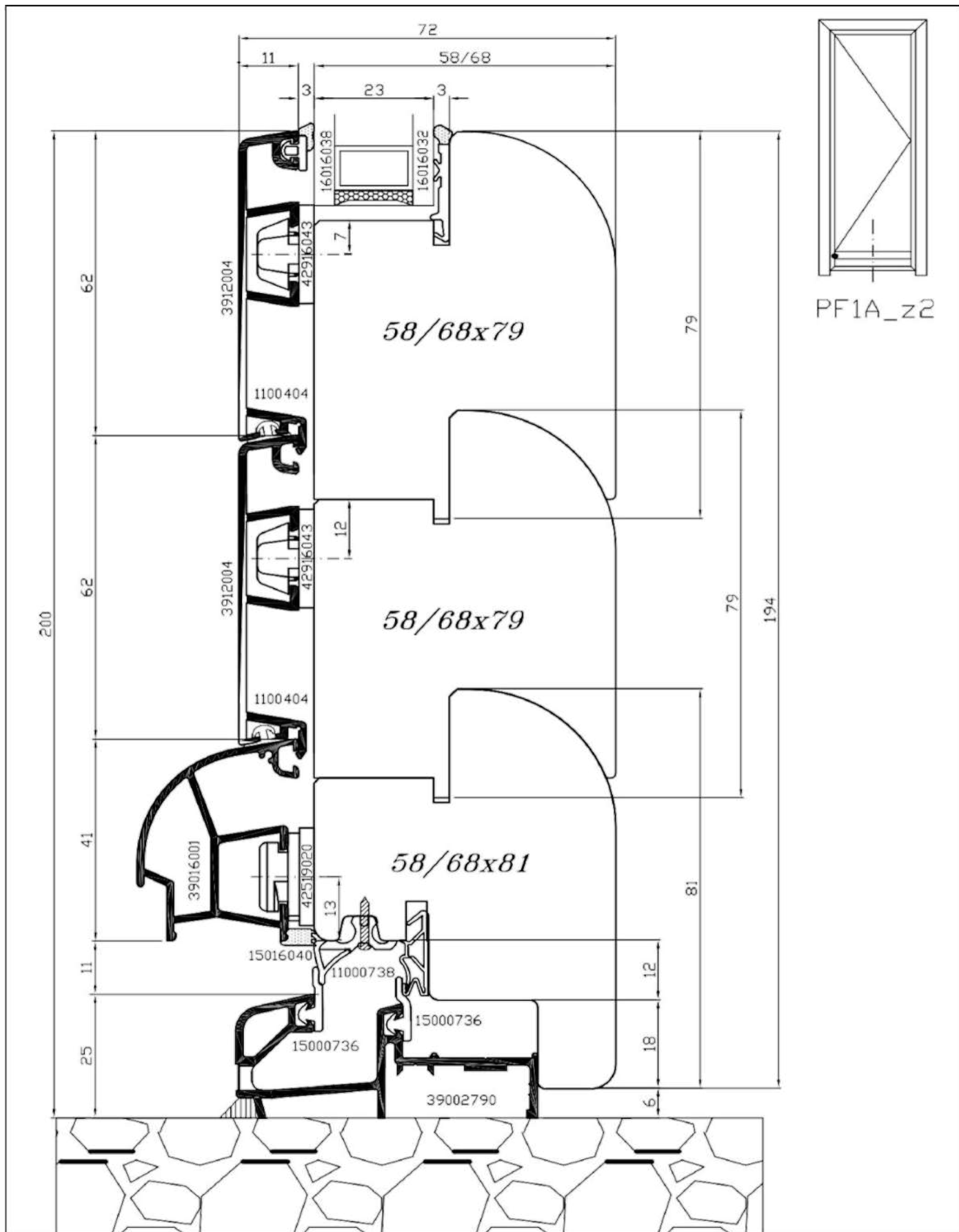

	Cliente Standard		File:06s316_050216	Sistema <b>ASTRO 6</b> 06S
			REV. 04	Scala Disegno Fuori Scala
				Tolleranze Generali ± 0,5 mm
Descrizione: <b>SEZIONE VERTICALE TRAVERSO INFERIORE PORTAFINESTRA</b>				PAGINA <b>316</b>

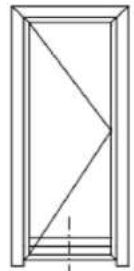
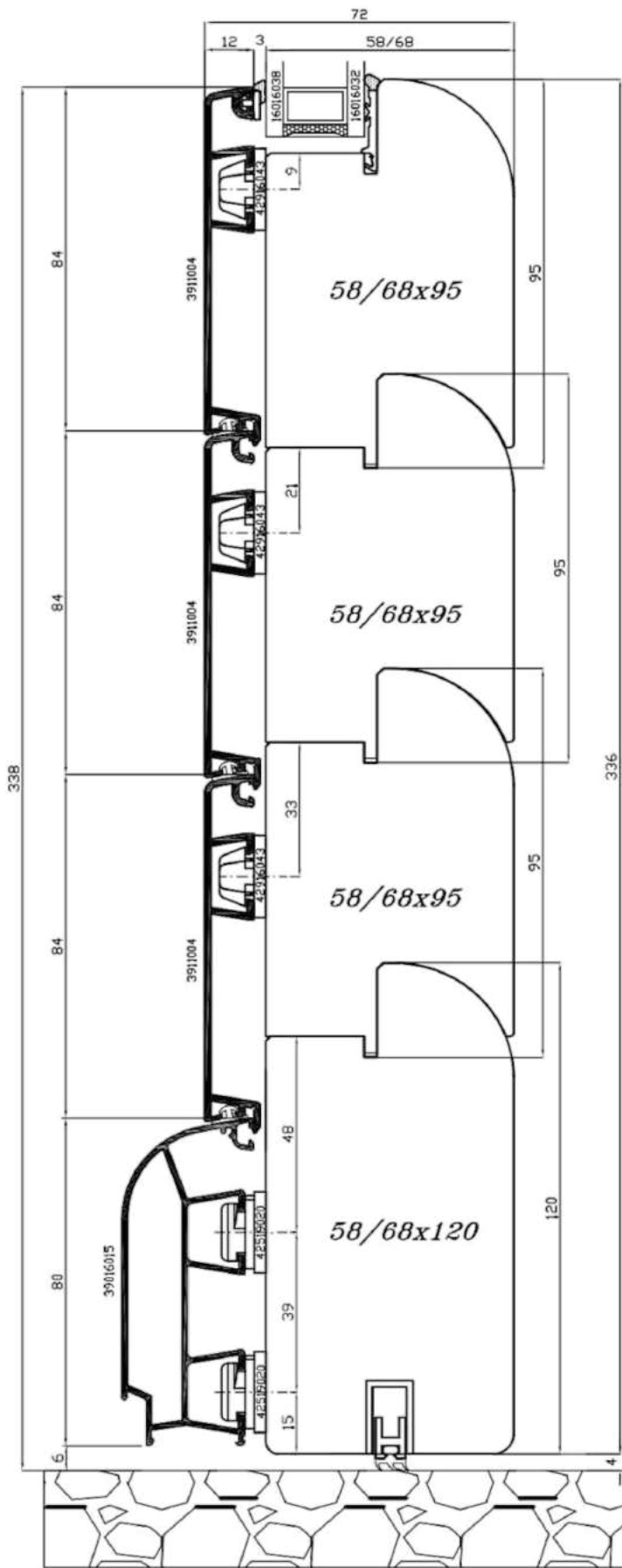

PF1A\_23

Disegnatore : L.F. Data Emissione 17/02/2005

Approvato da : G.N. Cliente Standard



File:06s316v15\_050516

REV. 04

Sistema **ASTRO 6** 06S

Scala Disegno Fuori Scala

Tolleranze Generali  $\pm 0,5\text{mm}$

Descrizione: **SEZIONE VERTICALE TRAVERSO  
INFERIORE PORTAFINESTRA**

PAGINA

**316v15**

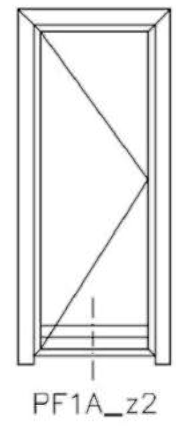
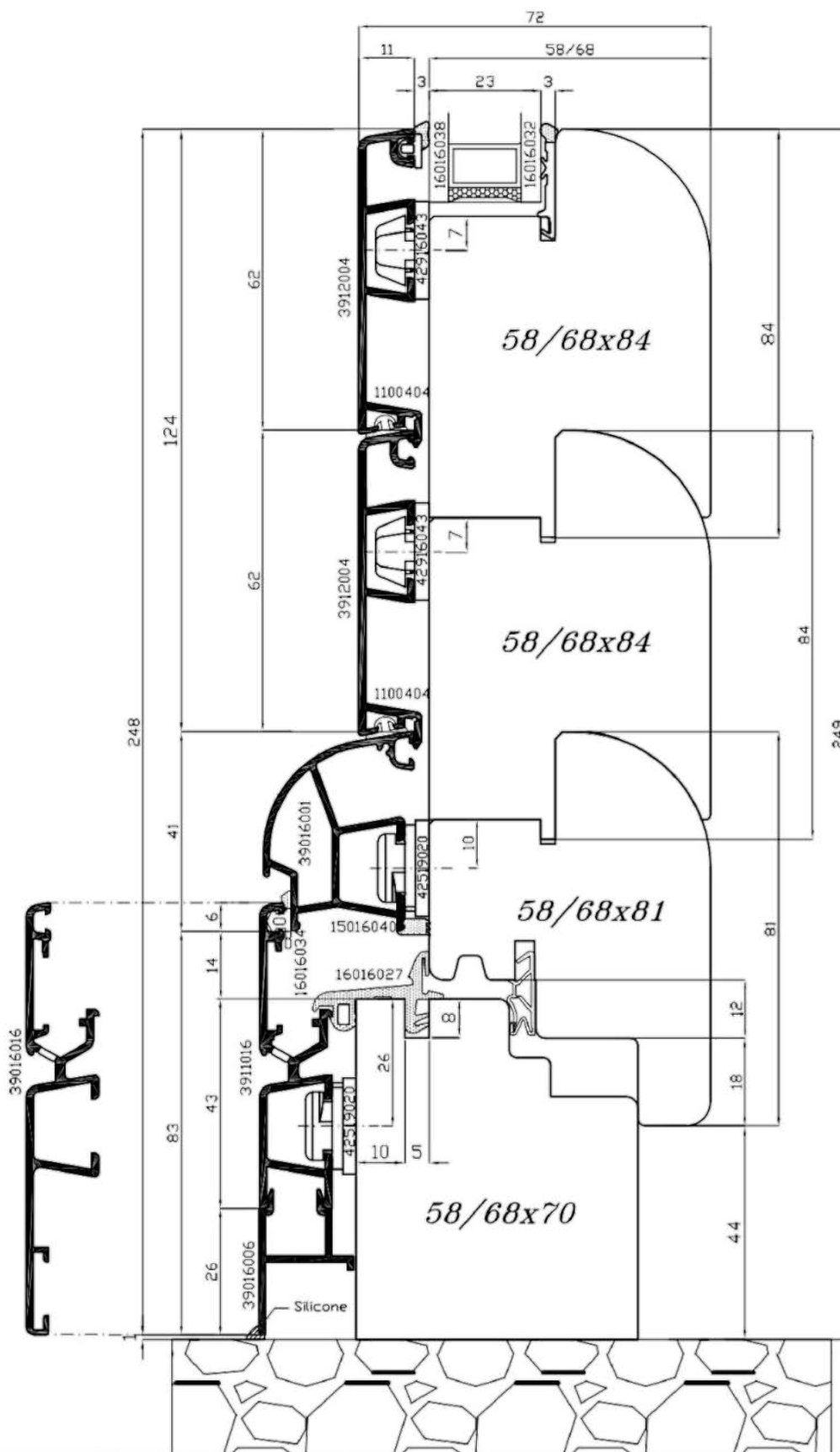

			Sistema <b>ASTRO 6</b> 06S
Cliente Standard			Scala Disegno Fuori Scala
			Tolleranze Generali ± 0,5mm
Descrizione: <b>SEZIONE VERTICALE TRAVERSO INFERIORE PORTAFINESTRA</b>			PAGINA <b>316v16</b>
Mod_35_REV01			

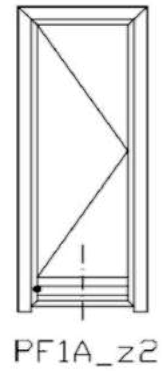
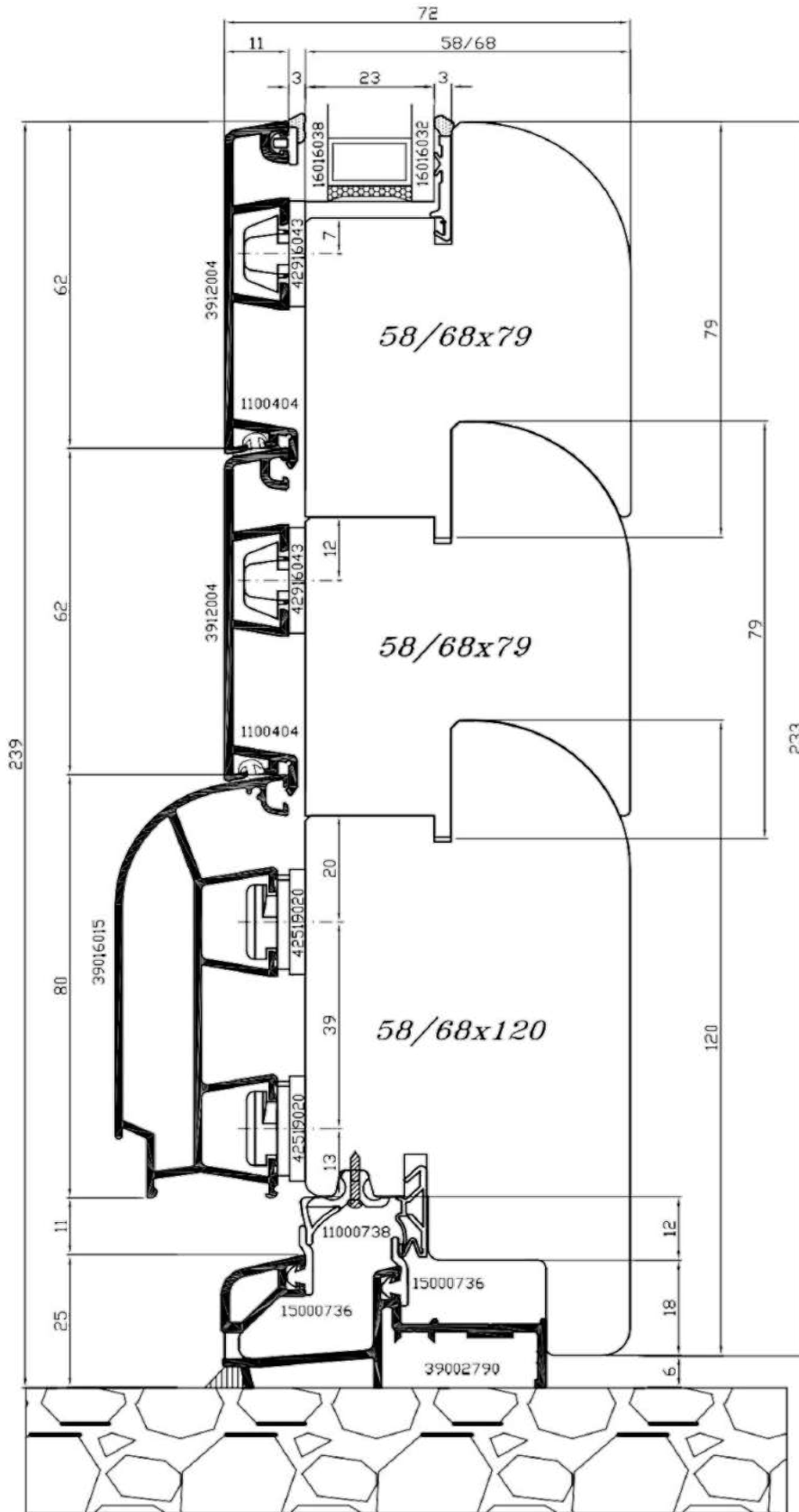

Disegnatore :	L.F.	Data Emissione 17/02/2005		File:06s316v2_050217	Sistema <b>ASTRO 6</b> 06S
Approvato da :	G.N.	Cliente Standard		REV. 04	Scala Disegno Fuori Scala
Descrizione: <b>SEZIONE VERTICALE TRAVERSO INFERIORE PORTAFINESTRA</b>					FACINA <b>316v2</b>
Mod_35_REV01					

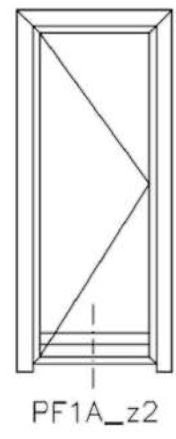
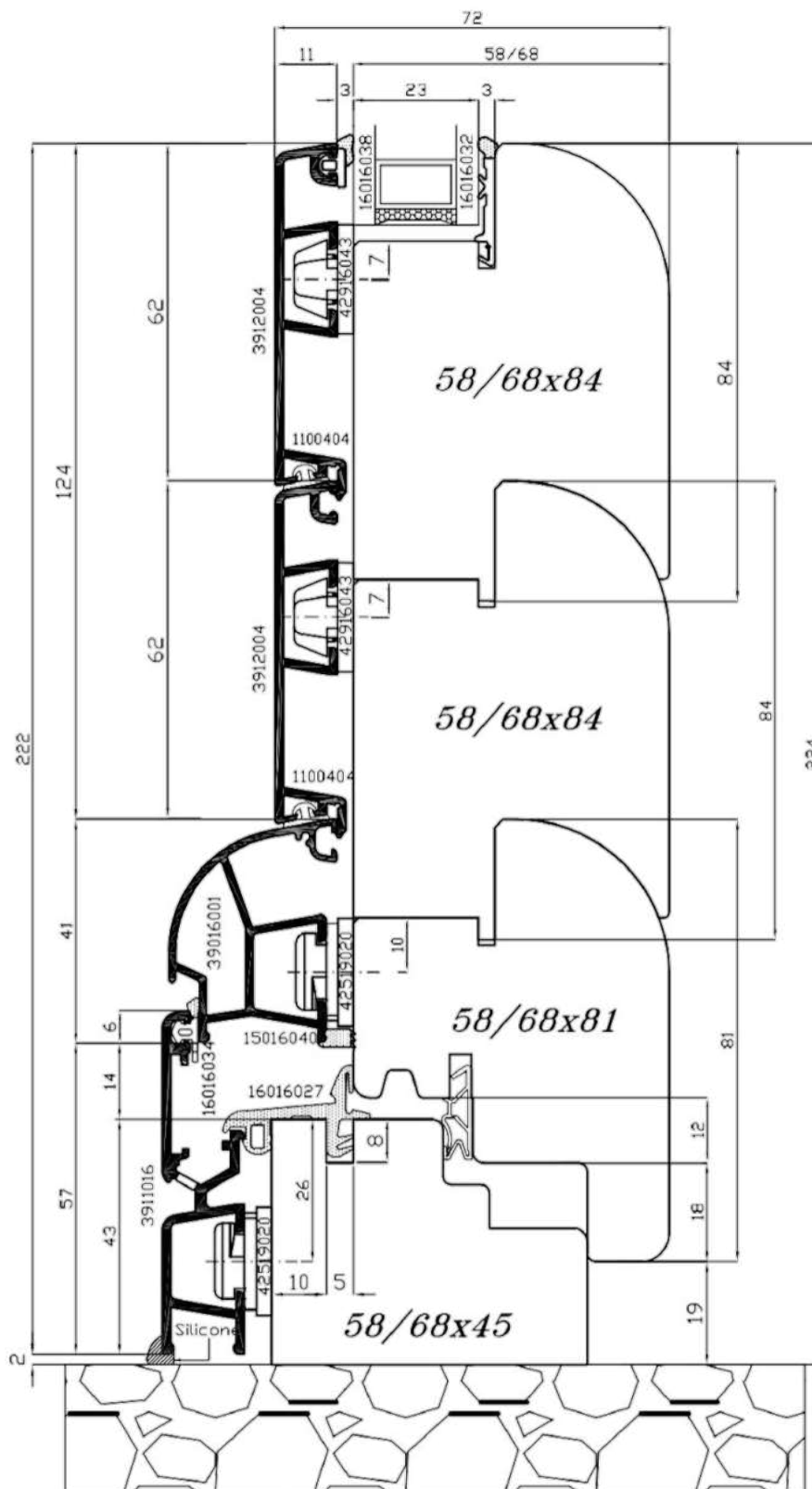

			Sistema <b>ASTRO 6</b> 065
Cliente Standard			Scala Disegno Fuori Scala
			Tolleranze Generali ± 0,5mm
Descrizione: <b>SEZIONE VERTICALE TRAVERSO INFERIORE PORTAFINESTRA</b>			PAGINA
Mod_35_REV01			



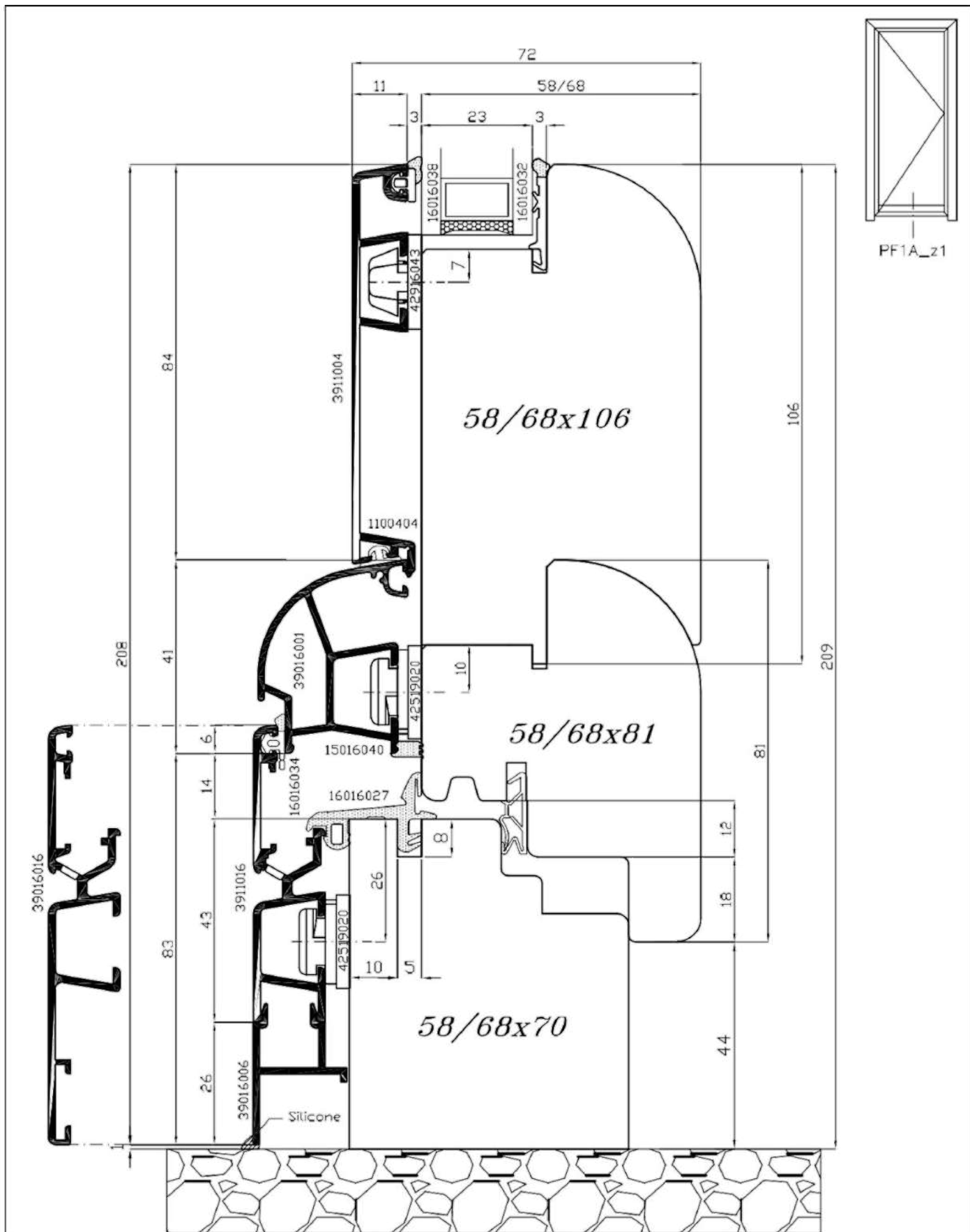

Approvato da : G.N.    Cliente Standard			Sistema <b>ASTRO 6</b> 06S
			Scala Disegno    Fuori Scala Tolleranze Generali    ± 0,5mm
Descrizione: <b>SEZIONE VERTICALE TRAVERSO INFERIORE PORTAFINESTRA</b>			PAGINA <b>316v23</b>
Mod_35_REV01			



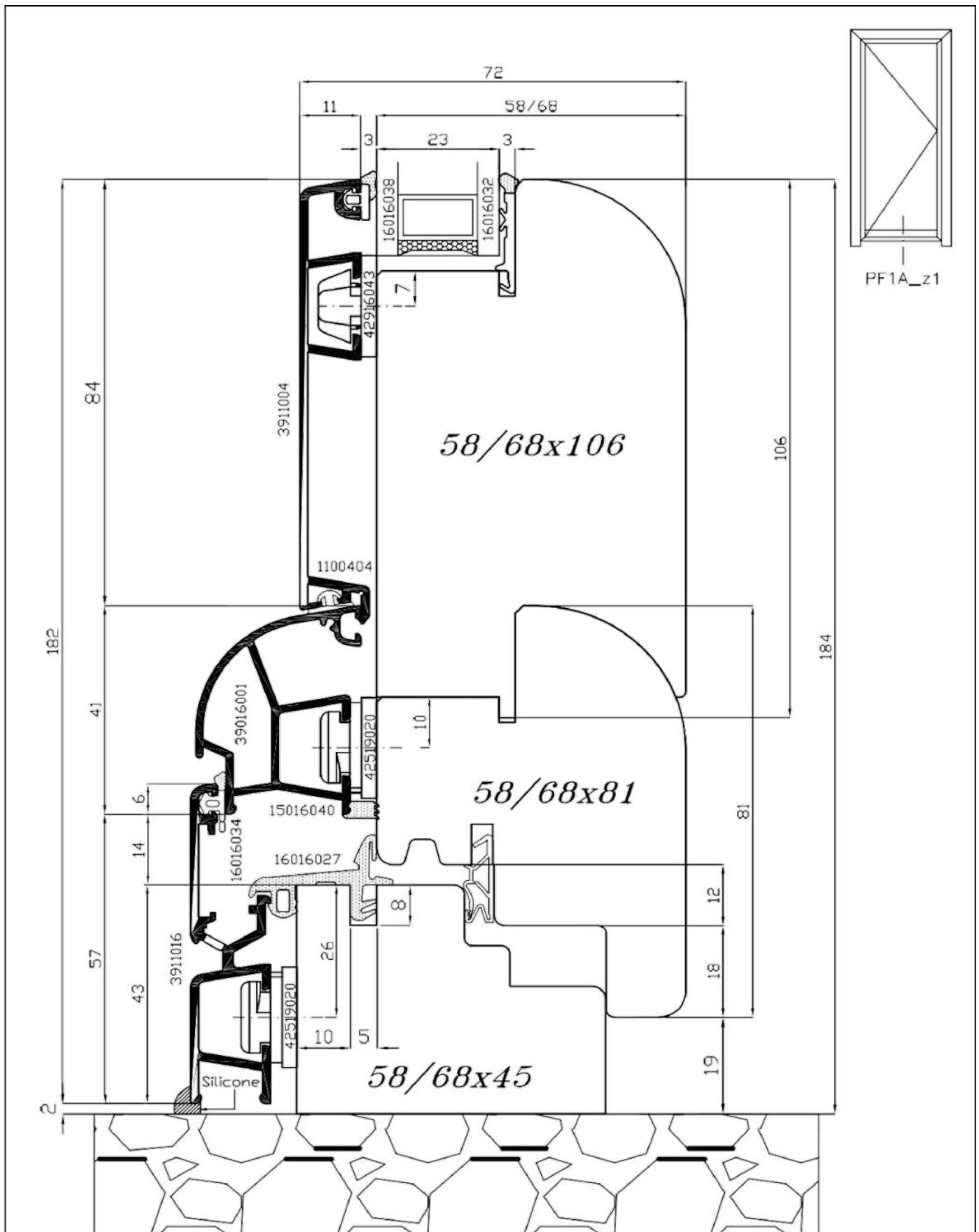

			Sistema Astro 6	06S
	Cliente Standard		Scala Disegno	1:1
			Tolleranze Generali	± 0,5mm
Descrizione: <b>SEZIONE VERTICALE TRAVERSO INFERIORE PORTAFINESTRA</b>			PAGINA <b>316v24</b>	

Mod\_35\_REV01

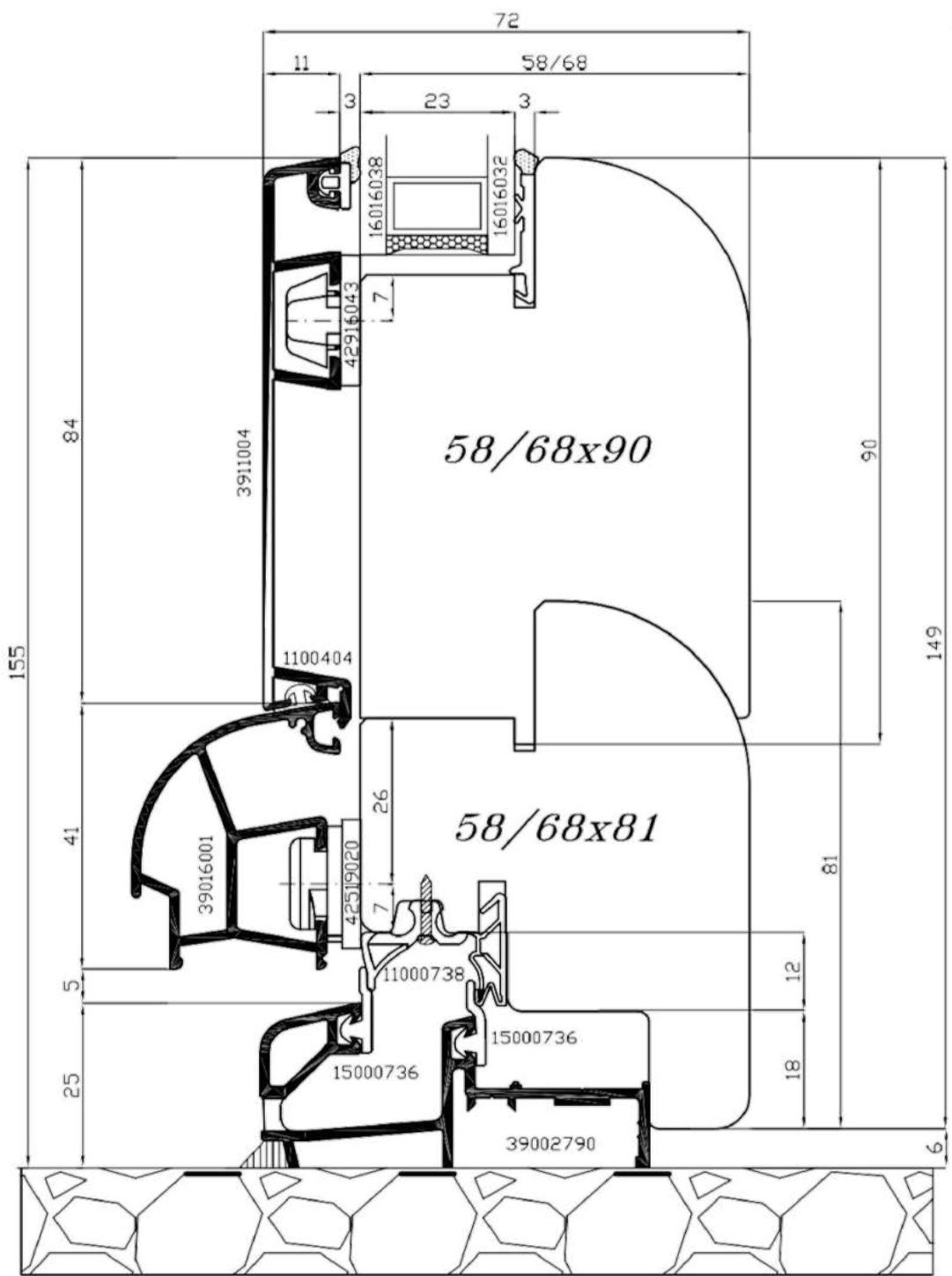

				Sistema <b>ASTRO 6</b> 06S
	Cliente Standard			Scala Disegno 1:1
				Tolleranze Generali ± 0,5mm
Descrizione:	<b>SEZIONE VERTICALE TRAVERSO INFERIORE PORTAFINESTRA</b>			PAGINA <b>316v25</b>

Mod\_35\_REV01

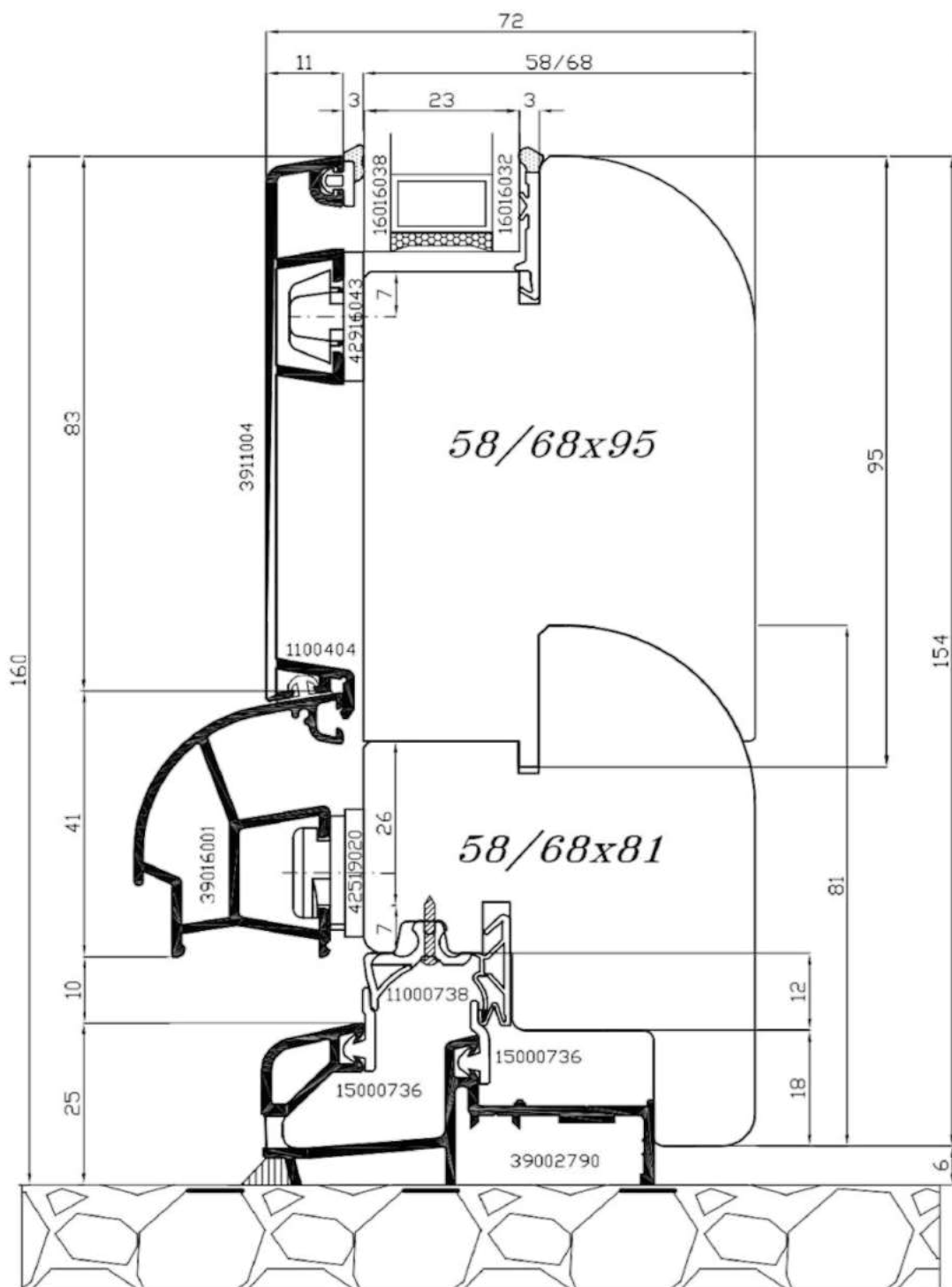

Disegnatore : L.F. Data Emissione 10/02/2006

Approvato da : G.N. Cliente Standard



File:06s316v25\_060210

REV. 00

Sistema **ASTRO 6** 06S

Scala Disegno 1:1

Tolleranze Generali ± 0,5mm

Descrizione: **SEZIONE VERTICALE TRAVERSO  
INFERIORE PORTAFINESTRA**

PAGINA

**316v25A**



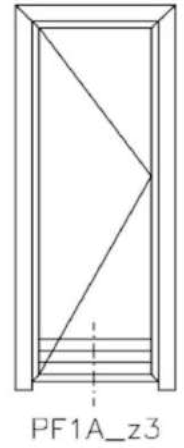
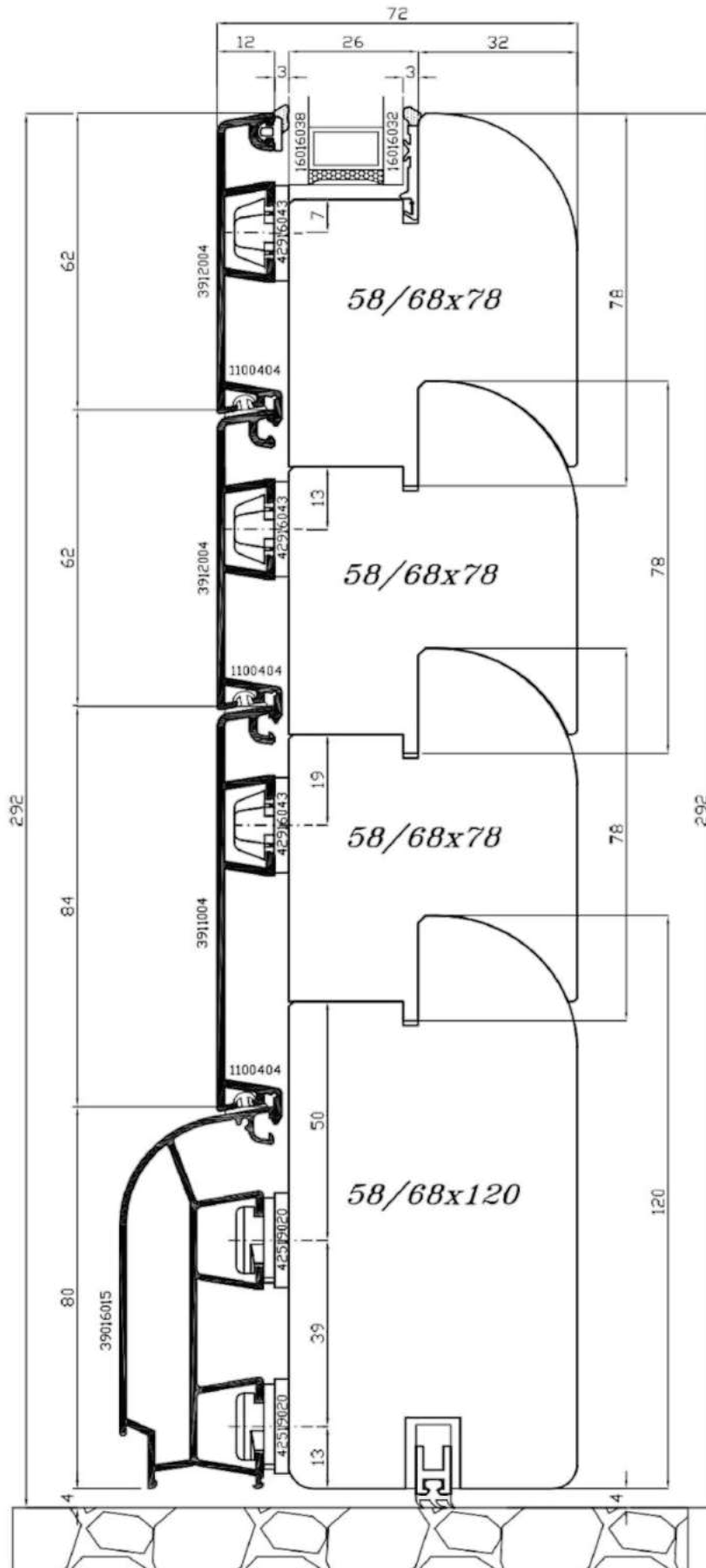

Disegnatore : L.F.	Data Emissione 22/06/2006		File:06s316v26A_060622	Sistema <b>ASTRO 6</b> 06S
Approvato da : G.N.	Cliente Standard		REV. 00	Scala Disegno Fuori Scala
Descrizione: <b>SEZIONE VERTICALE TRAVERSO INFERIORE PORTAFINESTRA</b>			Tolleranze Generali ± 0,5mm	PAGINA
Mod_35_REV01			<b>316v26A</b>	



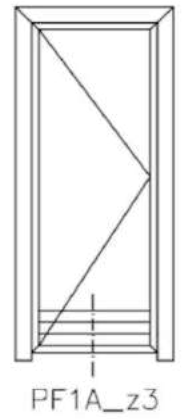
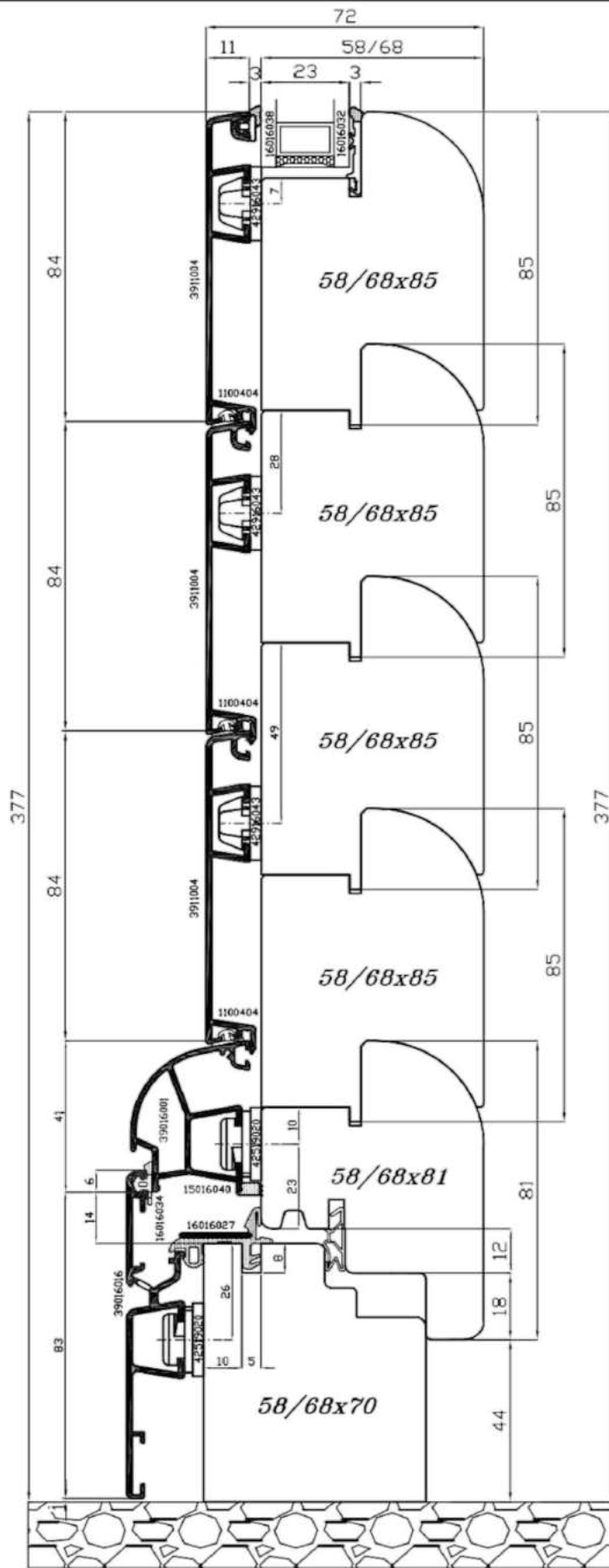

Disegnatore : L.F. Data Emissione 17/10/2006

Approvato da : G.N. Cliente Standard



File:06s316v28\_061017

REV. 00

Sistema **ASTRO 6** 06S

Scala Disegno Fuori Scala

Tolleranze Generali  $\pm 0,5\text{mm}$

Descrizione: **SEZIONE VERTICALE TRAVERSO  
INFERIORE PORTAFINESTRA**

PAGINA

**316v28**

Mod\_35\_REV01



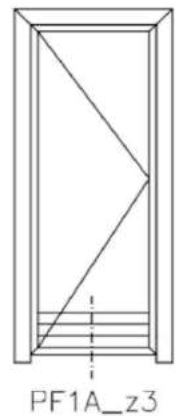
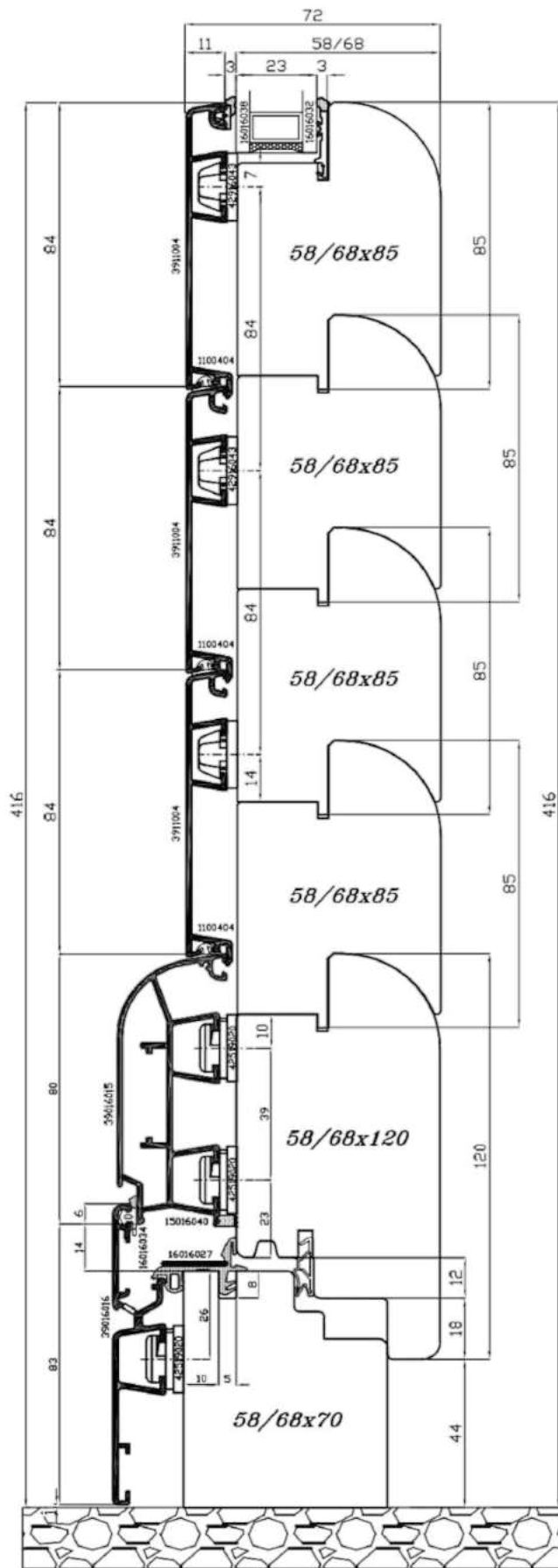

Disegnatore : L.F.	Data Emissione 17/10/2006		File:06s316v29_061017	Sistema <b>ASTRO 6</b> 06S
Approvato da : G.N.	Cliente Standard		REV. 00	Scala Disegno Fuori Scala
Descrizione: <b>SEZIONE VERTICALE TRAVERSO INFERIORE PORTAFINESTRA</b>				Tolleranze Generali ± 0,5mm
Mod_35_REV01				PAGINA <b>316v29</b>

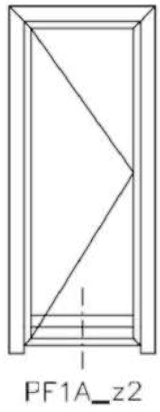
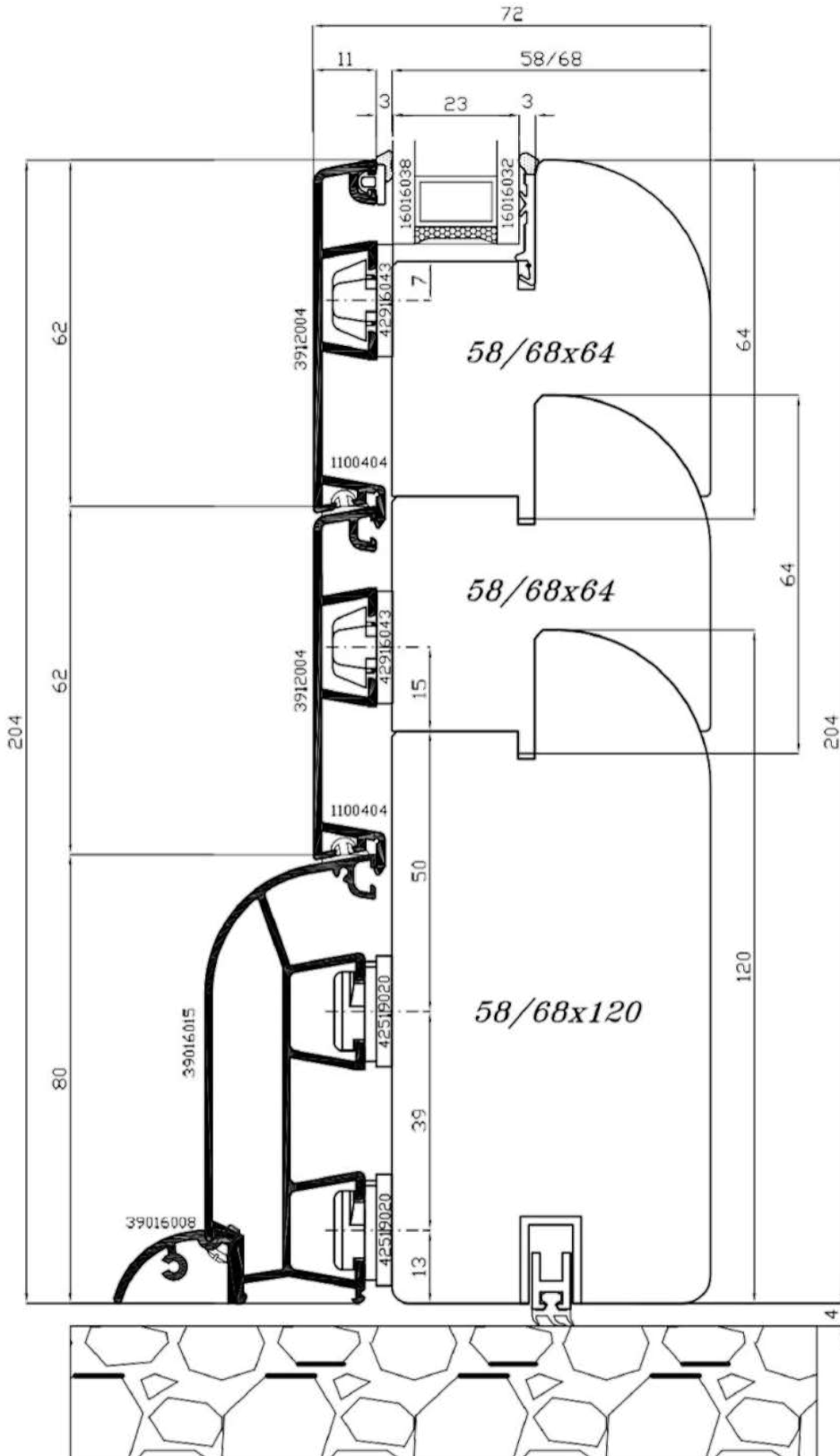

			Sistema <b>ASTRO 6</b> 06S
	Cliente Standard		Scala Disegno Fuori Scala
			Tolleranze Generali ± 0,5mm
Descrizione:	<b>SEZIONE VERTICALE TRAVERSO INFERIORE PORTAFINESTRA</b>		FACINA
Mod_35_REV01			

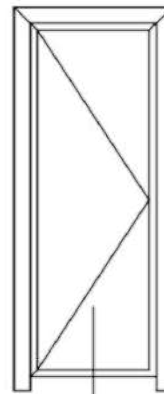
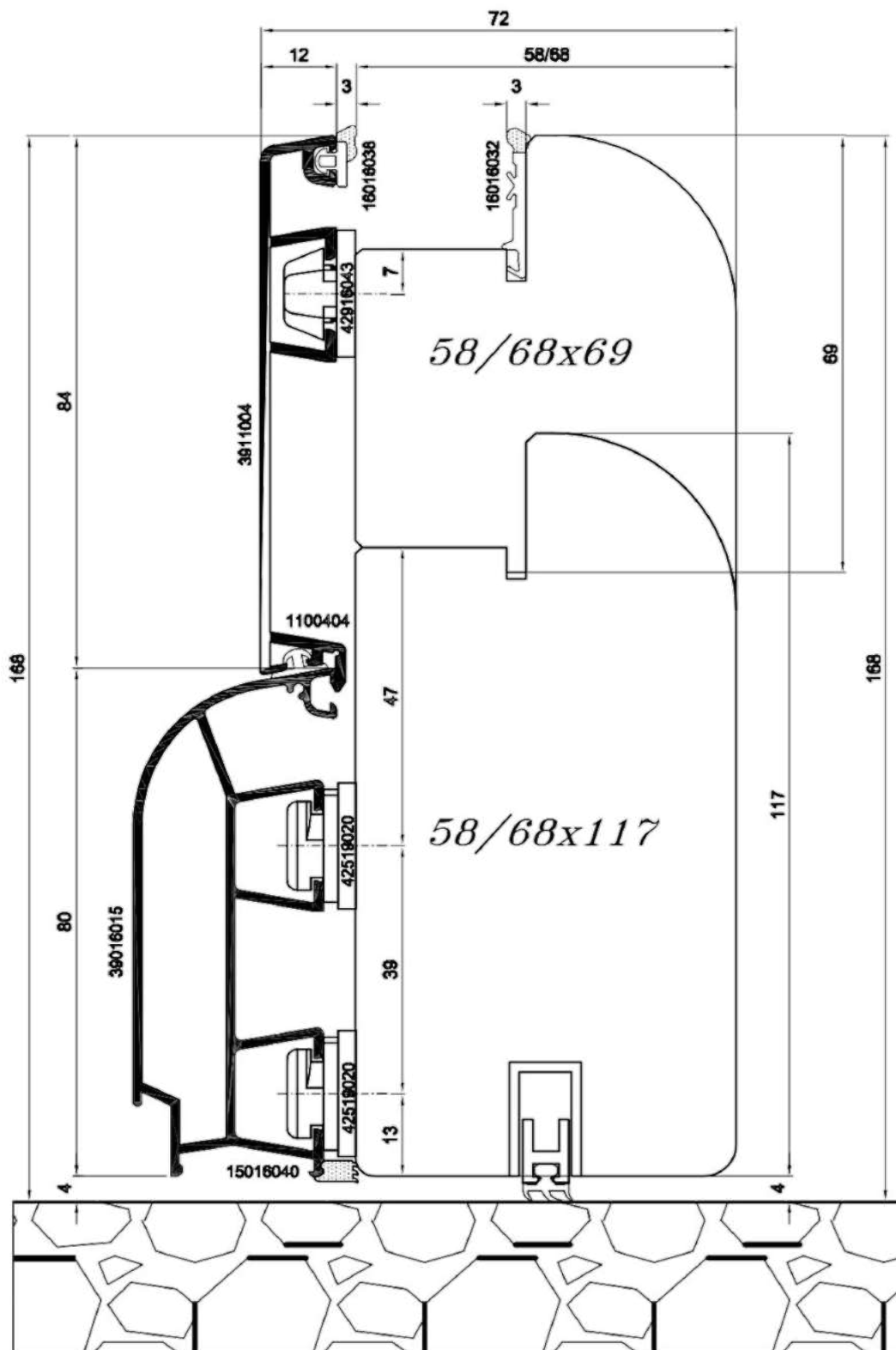

PF1A

	Cliente Standard		Sistema <b>ASTRO 6</b> 06S
			Scala Disegno 1:1
			Tolleranze Generali ± 0,5 mm
Descrizione: <b>SEZIONE VERTICALE TRAVERSO INFERIORE PORTAFINESTRA</b>			PAGINA

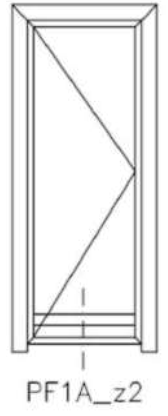
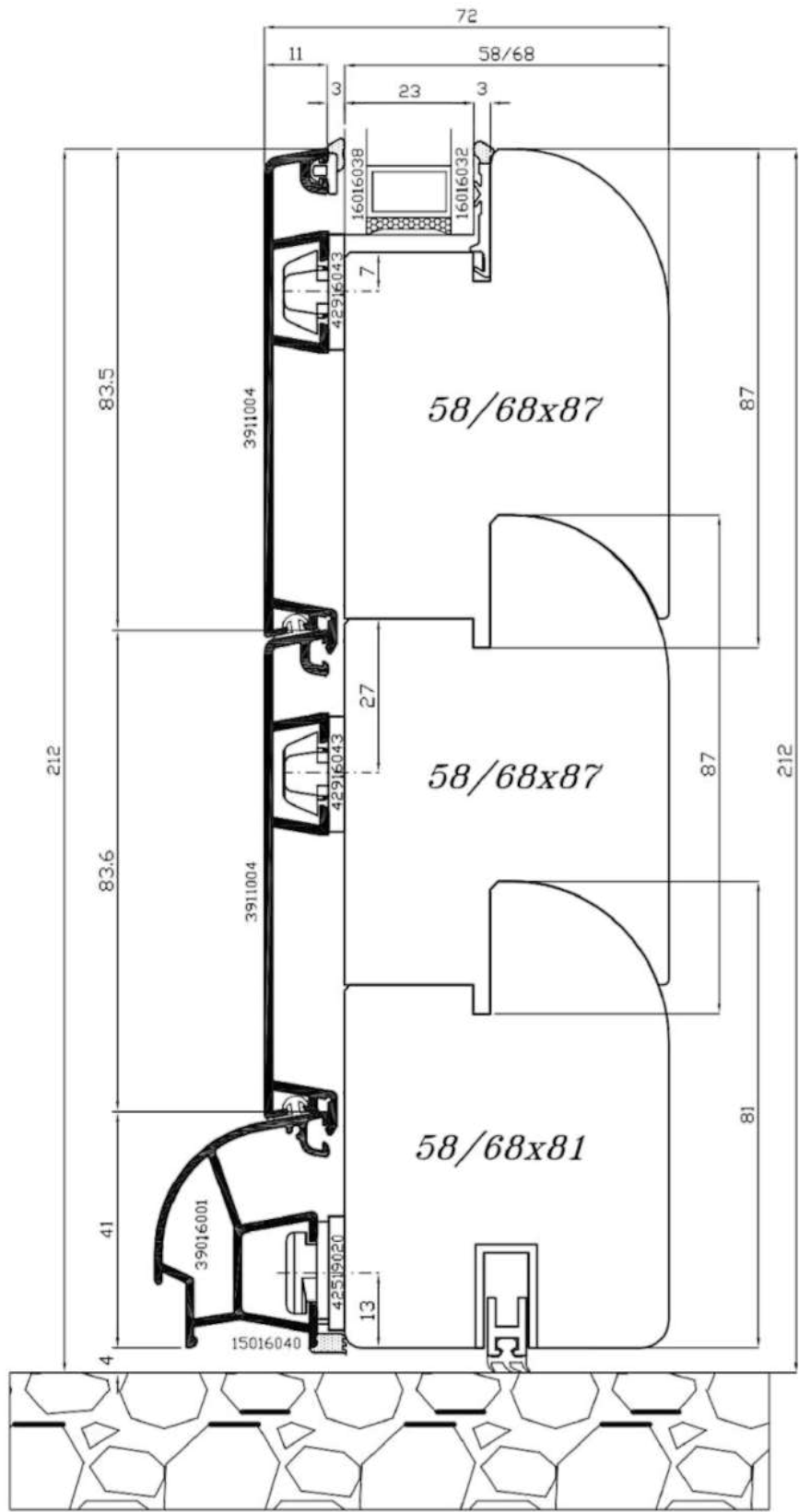

Disegnatore : L.F.	Data Emissione 23/05/2007		File:06s316v37_070523	Sistema <b>ASTRO 6</b> 06S
Approvato da : G.N.	Cliente Standard		REV. 00	Scala Disegno Fuori Scala
Descrizione: <b>SEZIONE VERTICALE TRAVERSO INFERIORE PORTAFINESTRA</b>			Tolleranze Generali ± 0,5mm	PAGINA
Mod_35_REV01			<b>316v37</b>	

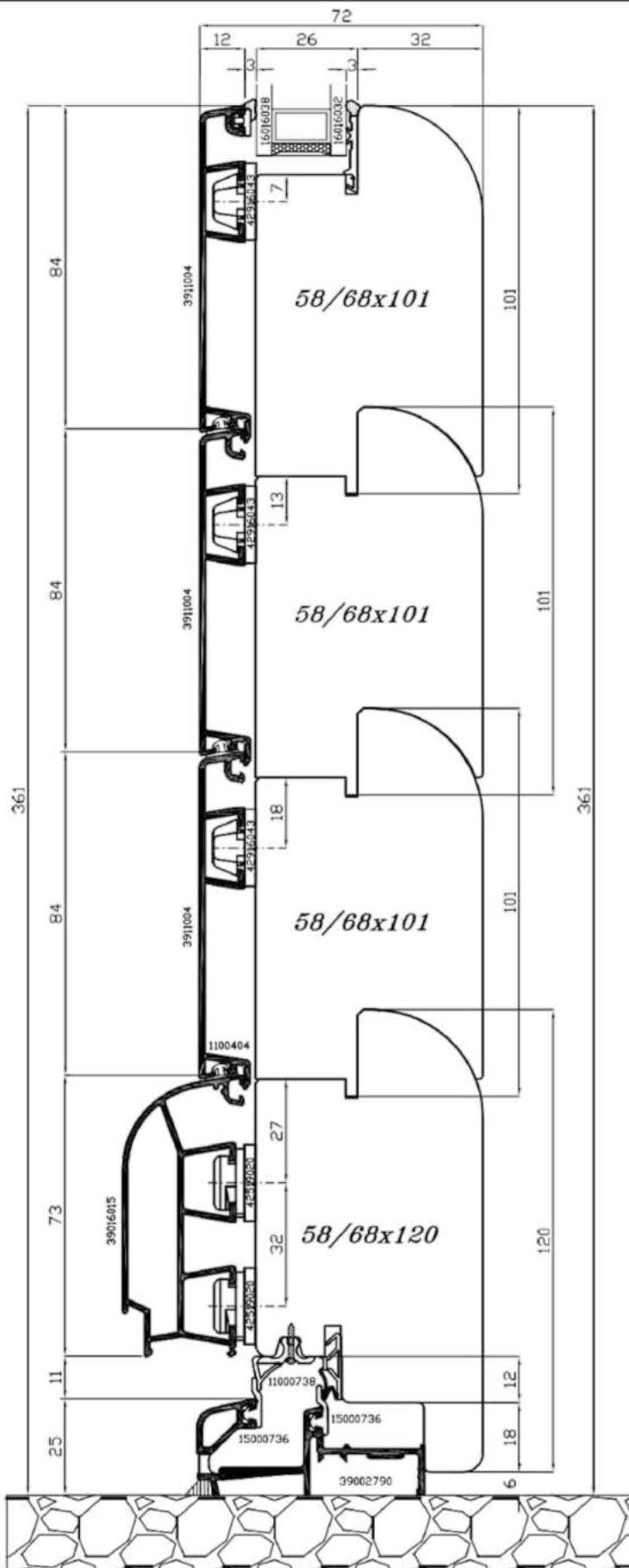

Disegnatore : L.F.      Data Emissione 04/12/2007

Approvato da : L.F.      Cliente Standard



File:06s316v38\_071204

REV. 00

Sistema **ASTRO 6**      06S

Scala Disegno      Fuori Scala

Tolleranze Generali      ± 0,5mm

Descrizione:

**SEZIONE VERTICALE TRAVERSO  
INFERIORE PORTAFINESTRA**

PAGINA

**316v38**

Mod\_35\_REV01

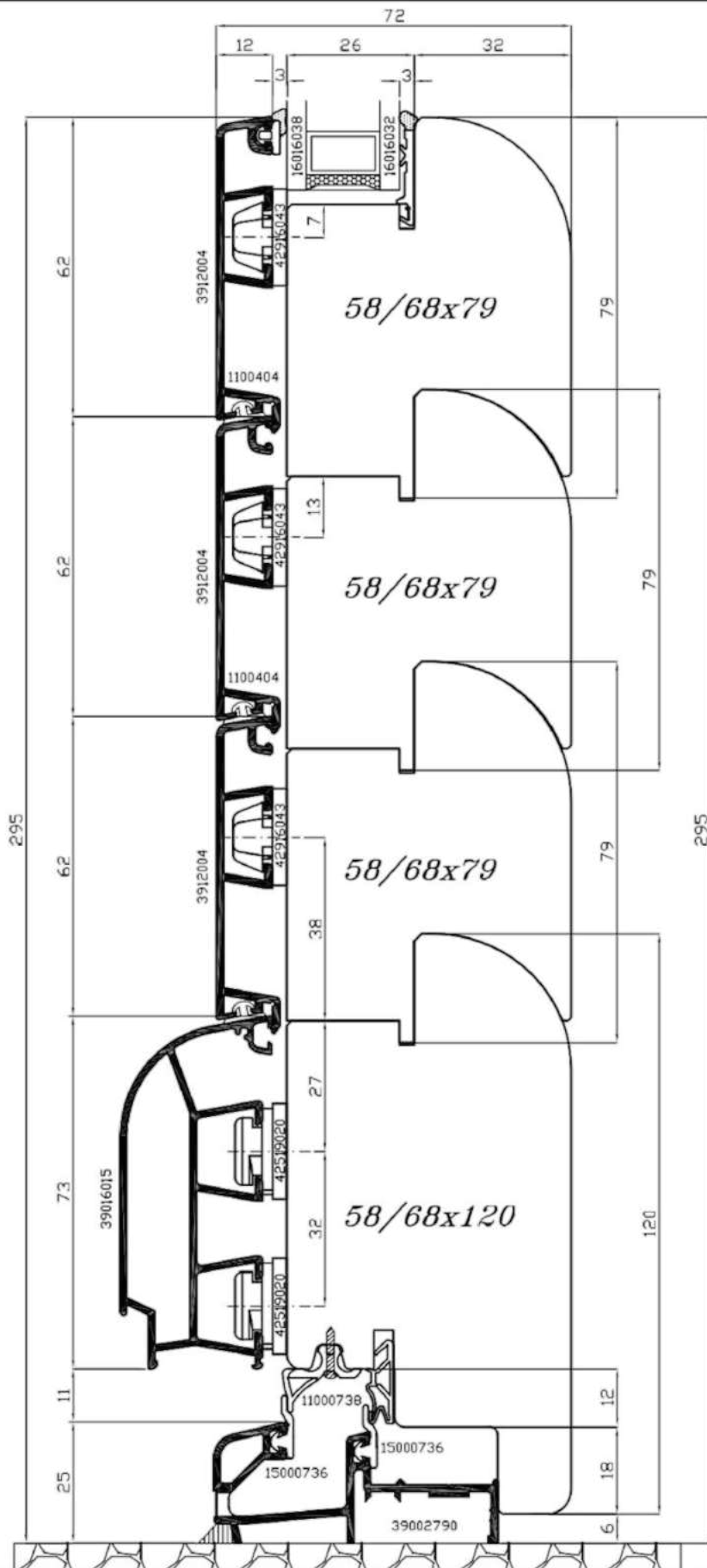

Disegnatore : L.F.      Data Emissione 04/12/2007

Approvato da : L.F.      Cliente Standard



File:06s316v39\_071204

REV. 00

Sistema **ASTRO 6**      06S

Scala Disegno      Fuori Scala

Tolleranze Generali      ± 0,5mm

Descrizione:

**SEZIONE VERTICALE TRAVERSO  
INFERIORE PORTAFINESTRA**

PAGINA

**316v39**



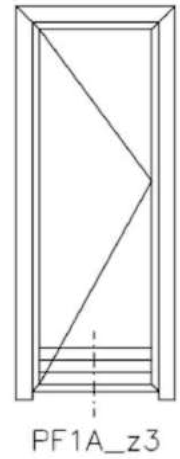
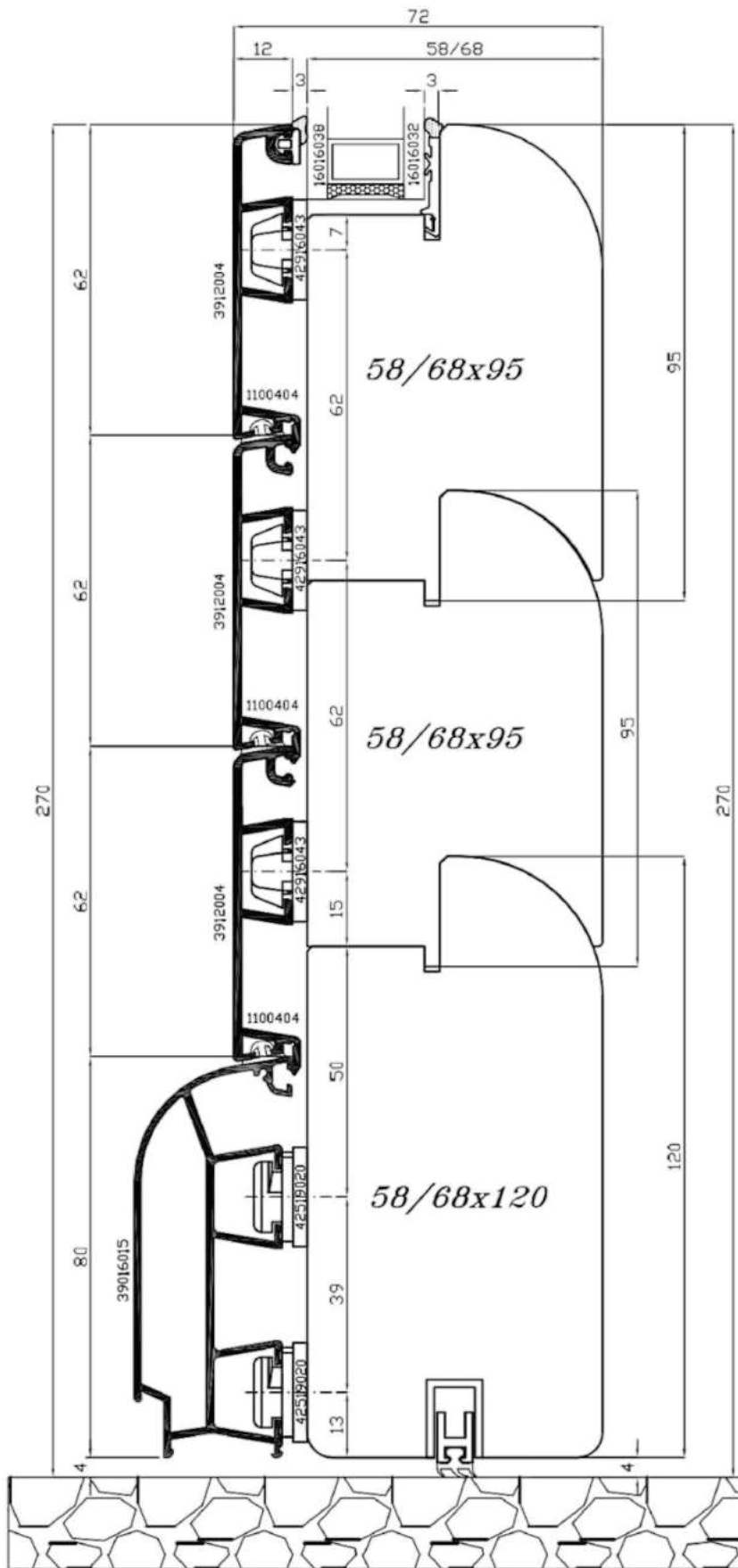

Disegnatore : L.F.	Data Emissione 06/12/2007		File:06s316v40_071206	Sistema <b>ASTRO 6</b> 06S
Approvato da : L.F.	Cliente Standard		REV. 00	Scala Disegno Fuori Scala
Descrizione: <b>SEZIONE VERTICALE TRAVERSO INFERIORE PORTAFINESTRA</b>				Tolleranze Generali ± 0,5mm
Mod_35_REV01				PAGINA <b>316v40</b>



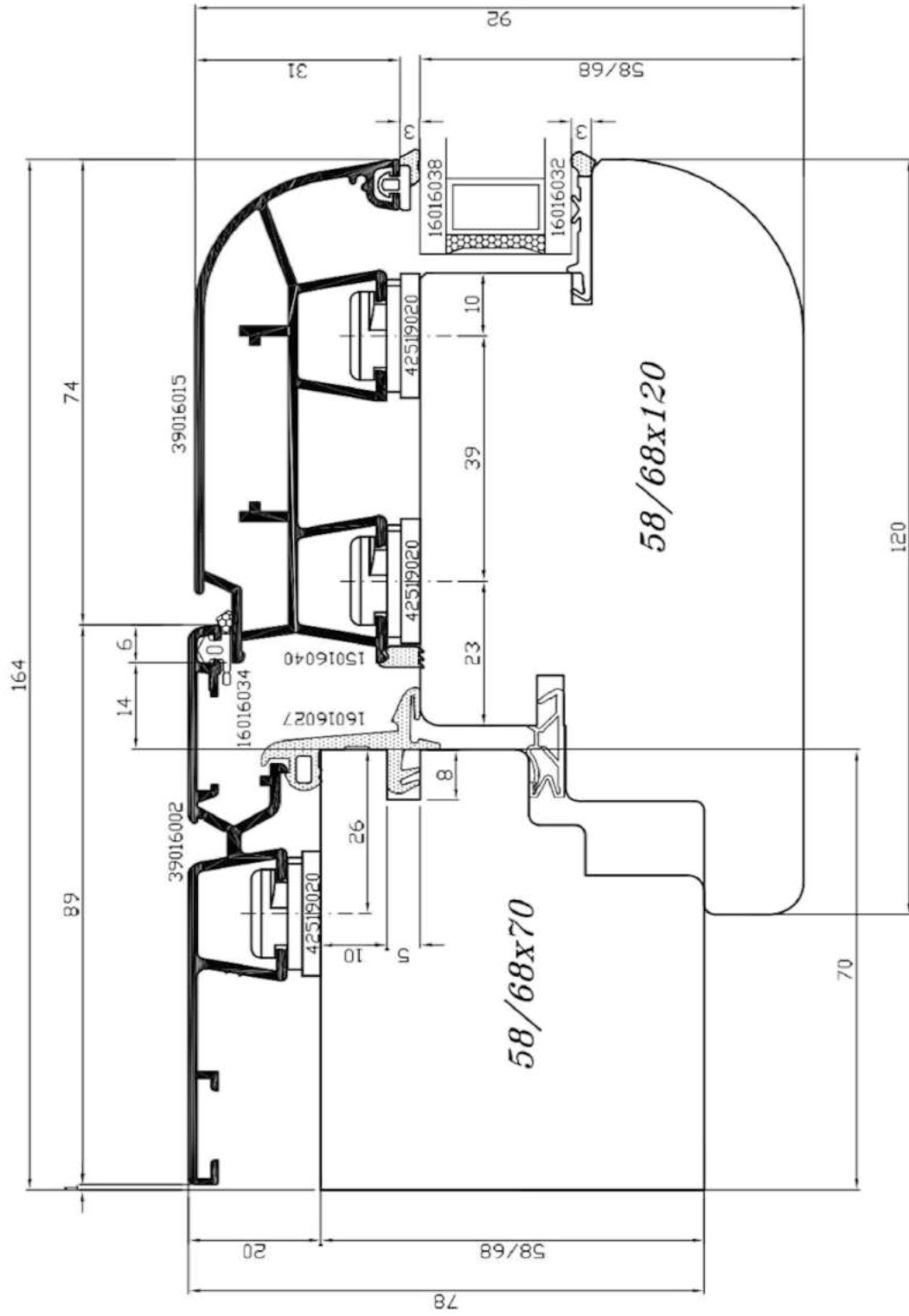
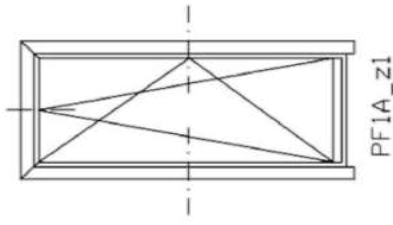

Disegnatore : L.F.	Data Emissione 17/10/2006	File:06s317v2_061017	Sistema <b>ASTRO 6</b>	D6S
Approvato da : G.N.	Cliente Standard	REV. 00	Scala Disegno	1:1
Descrizione: <b>SEZIONE ORIZZONTALE E VERTICALE ANTA LARGA</b>		Tolleranze Generali ± 0,5mm		
Mod_35_REV01		PAGINA <b>317v2</b>		

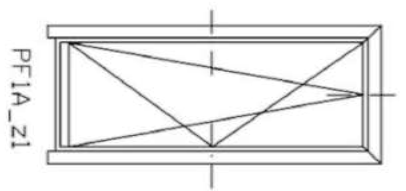
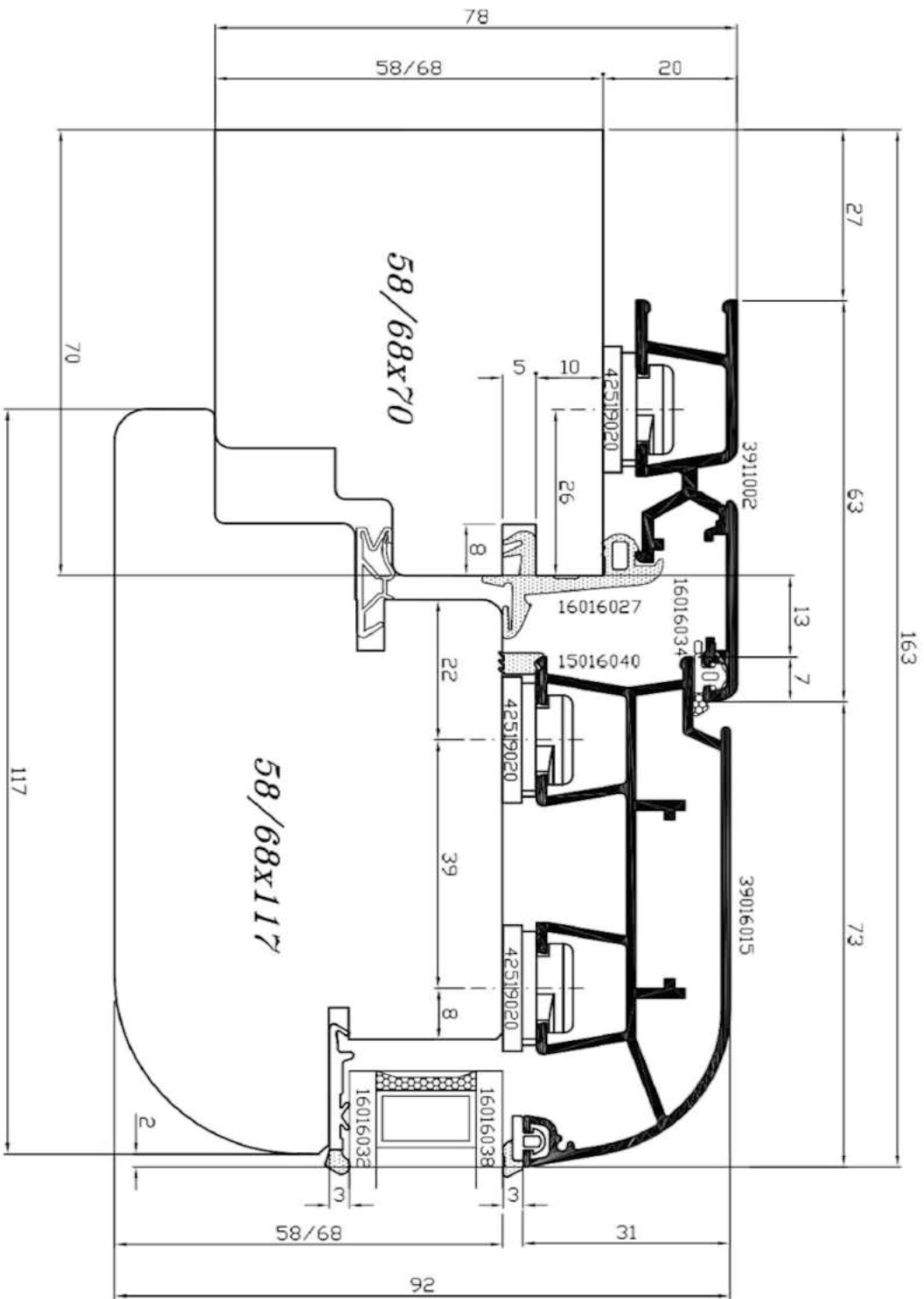

Disegnatore : L.F.	Data Emissione 17/02/2005		File:065317_050217	Sistema <b>ASTRO 6</b>	065
Approvato da : G.N.	Cliente Standard		REV. 04	Scala Disegno	1:1
Descrizione: <b>SEZIONE ORIZZONTALE E</b> <b>VERTICALE ANTA LARGA</b>			Tolleranze Generali	± 0.5mm	
Mod. 35_REV01			<b>PAGINA</b> <b>317v3</b>		





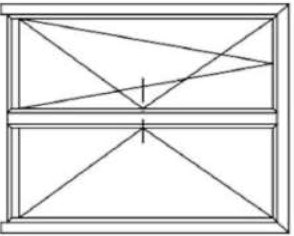
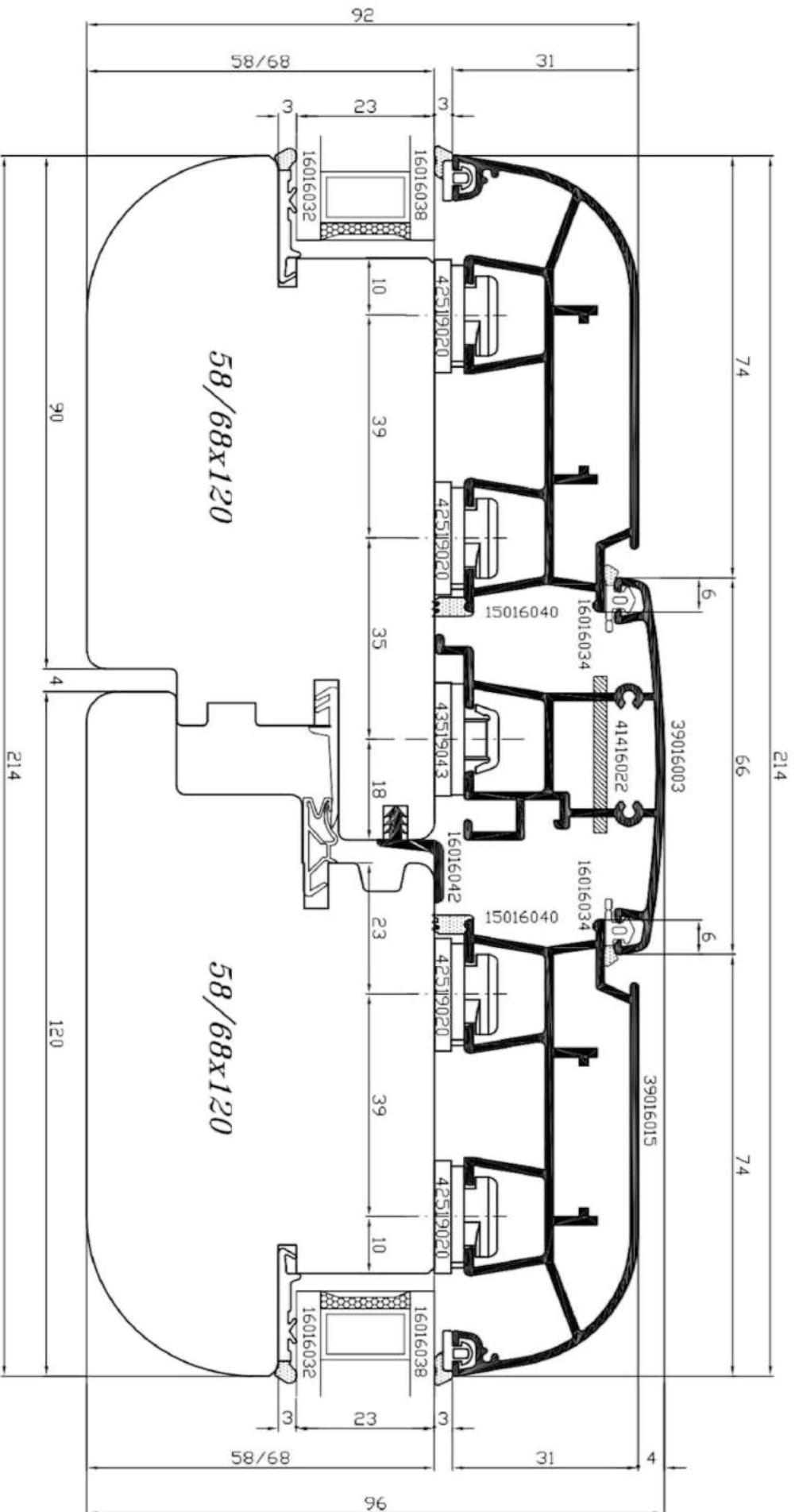

PF2A\_z1

Disegnatore : L.F.	Data Emisione 20/11/2006		File:06s318v1_061120	Sistema astro 6	06S
Approvato da : G.N.	Ciente Standard		REV. 00	Scala Disegno	1:1
Descrizione: <b>SEZIONE ORIZZONTALE</b> <b>SNODO CENTRALE</b>			Tolleranze Generali	± 0,5mm	
Mod. 35_REV01			<b>PAGINA</b> <b>318V1</b>		



PARTE TELAIO FISSO

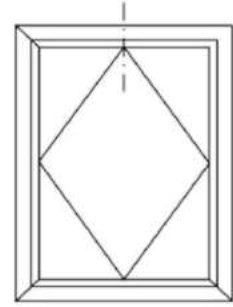

BILICO

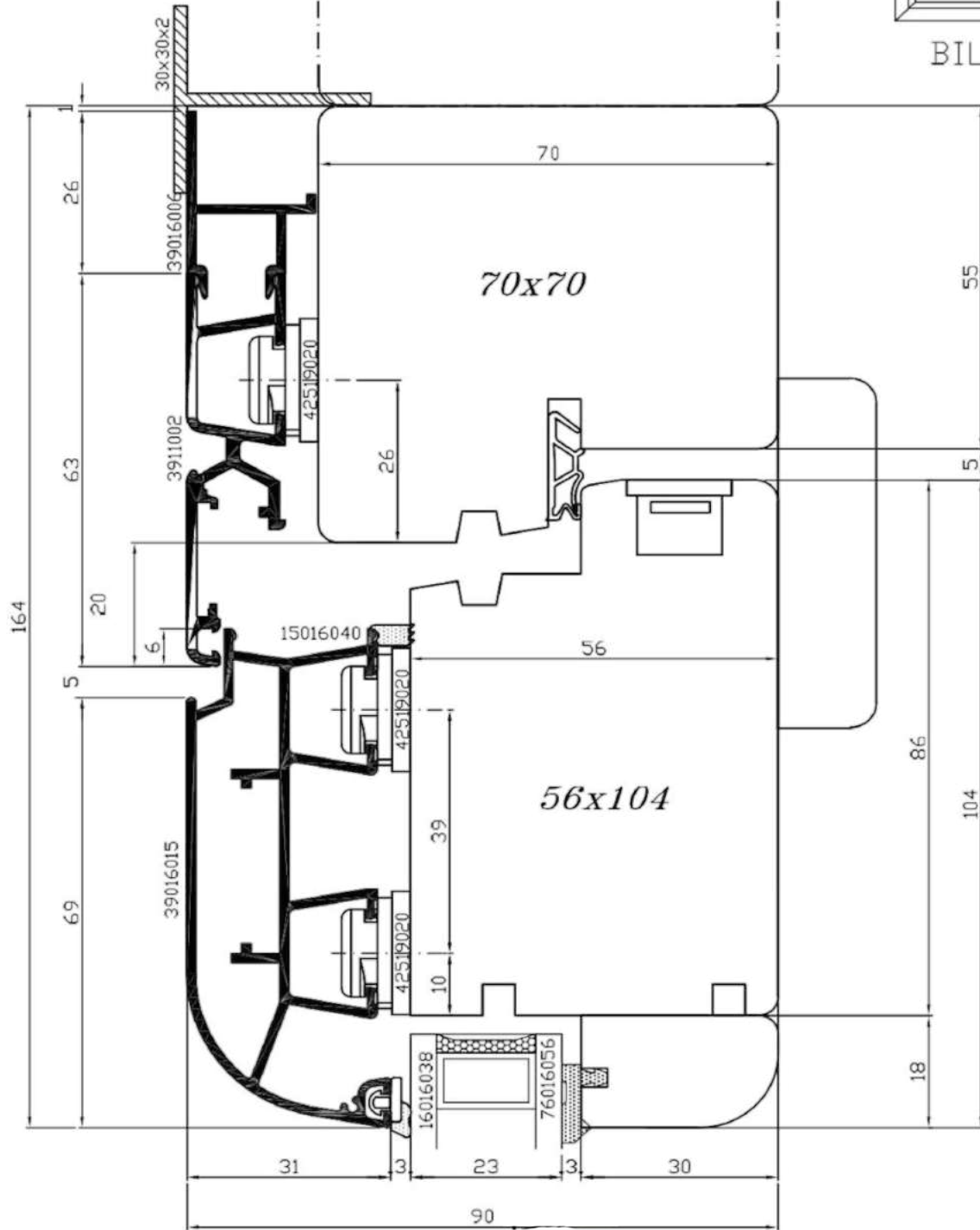

Disegnatore : M.B. Data Emissione 04/03/2005

Approvato da : M.B. Cliente Standard



File:06s319\_050304

REV. 04

Sistema **ASTRO 6** 06S

Scala Disegno 1:1

Tolleranze Generali ± 0,5 mm

Descrizione: **SEZIONE VERTICALE TRAVERSO SUPERIORE BILICO**

PAGINA

**319**

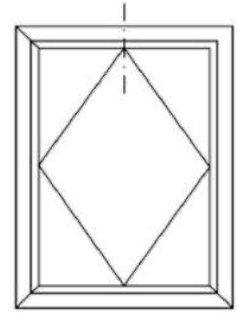
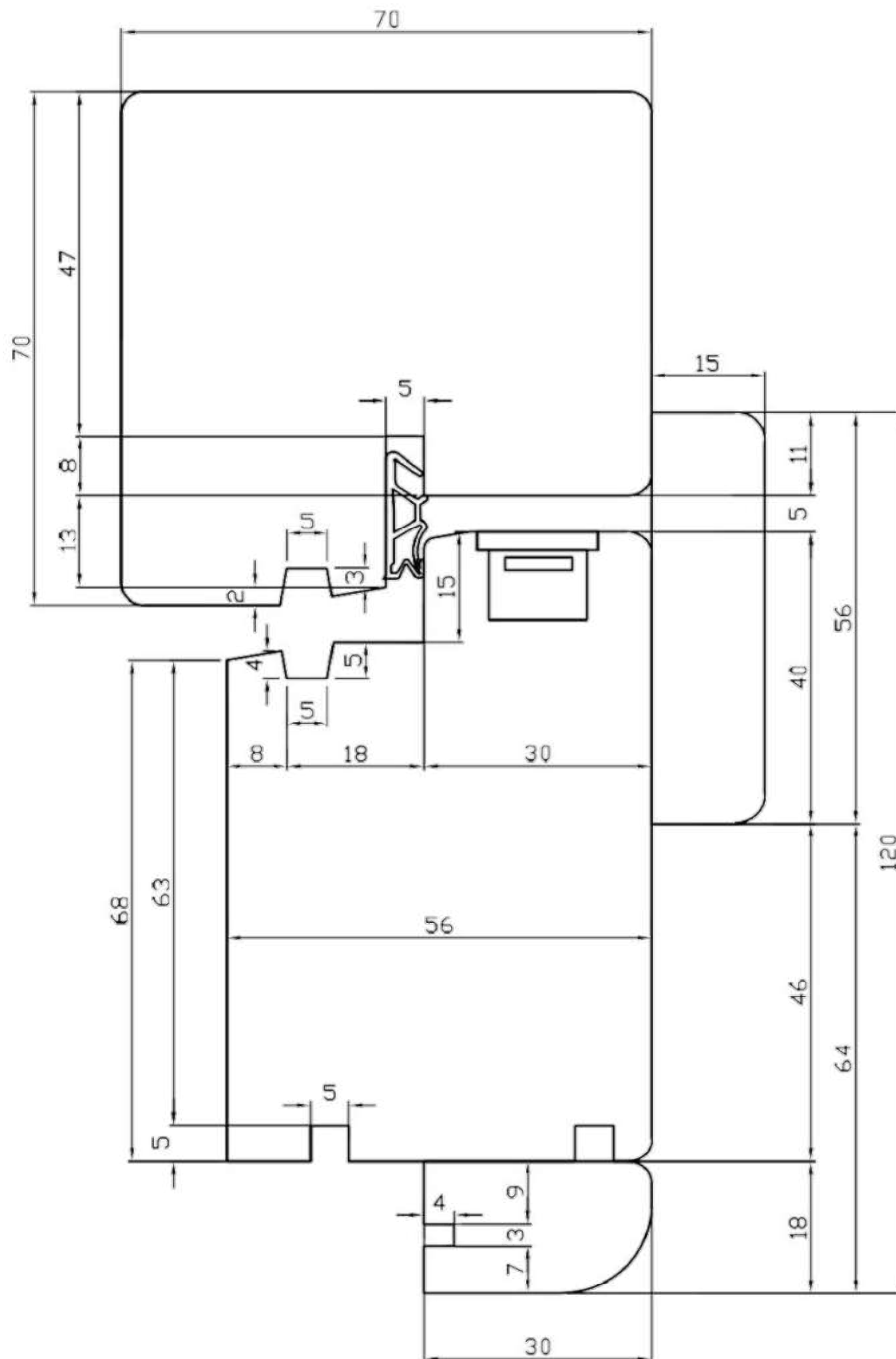

BILICO

SOLO PARTE LEGNO

			Sistema <b>ASTRO 6</b> 06S
	Cliente Standard		Scala Disegno 1:1
			Tolleranze Generali $\pm 0,5$ mm
Descrizione: <b>SEZIONE VERTICALE TRAVERSO SUPERIORE BILICO</b>			PAGINA
Mod_35_REV01			

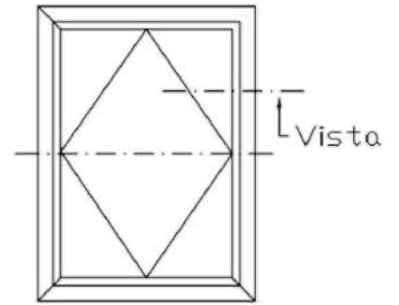

BILICO

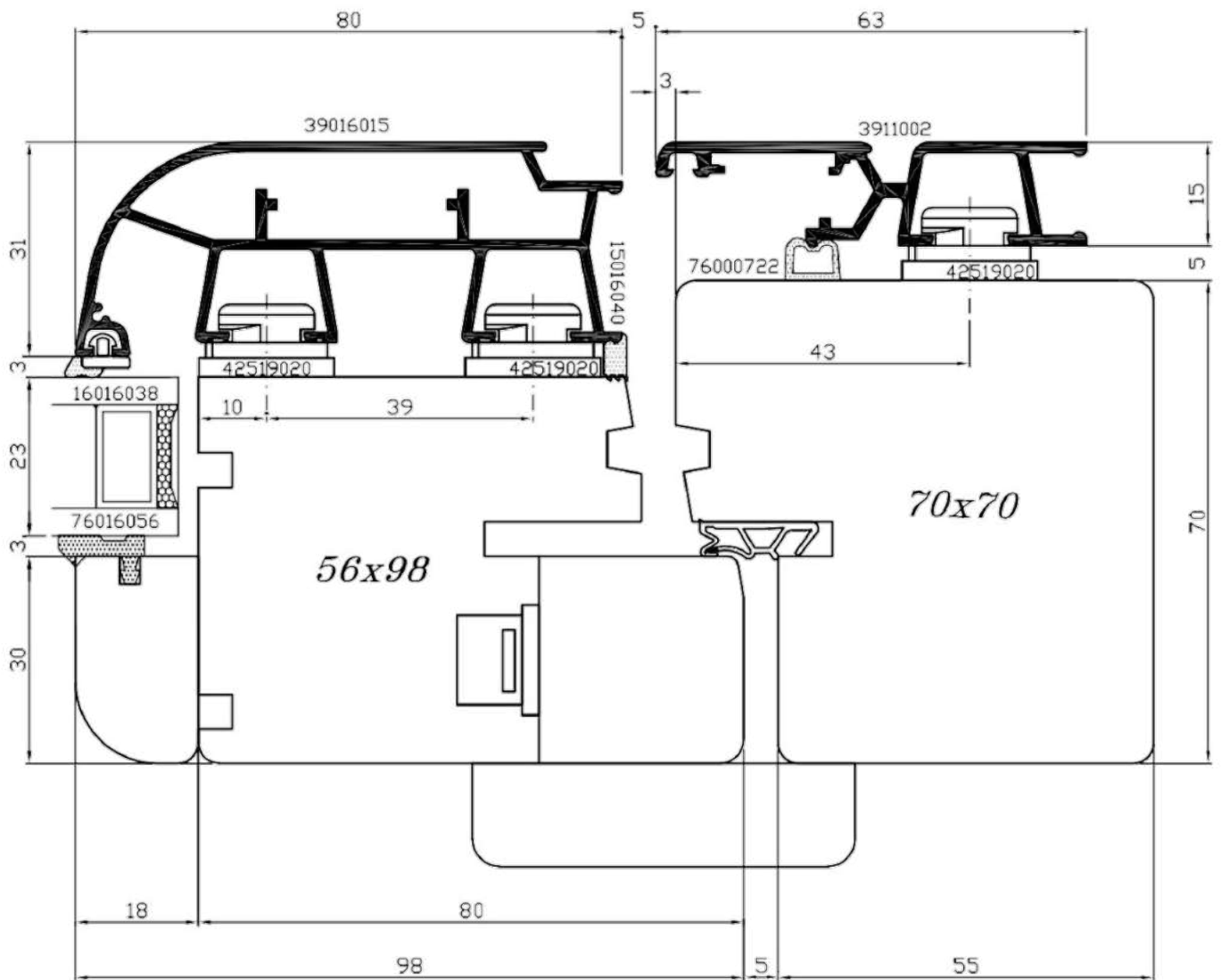

			Sistema <b>ASTRO 6</b> 06S
	Cliente Standard		Scala Disegno 1:1
			Tolleranze Generali ± 0,5 mm
Descrizione: <b>SEZIONE ORIZZONTALE MONTANTE BILICO ORIZZONTALE SOPRA CERNIERA</b>			PAGINA

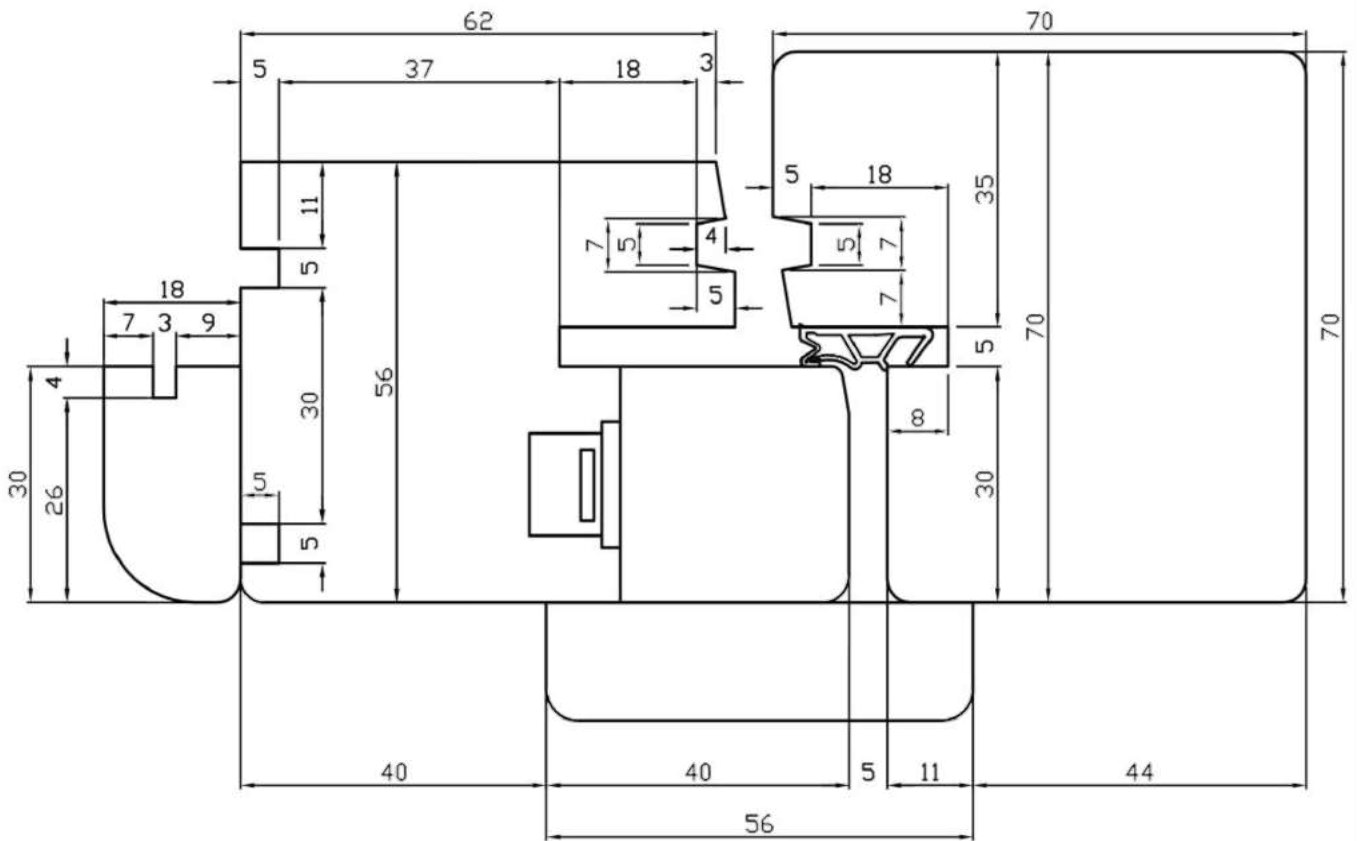
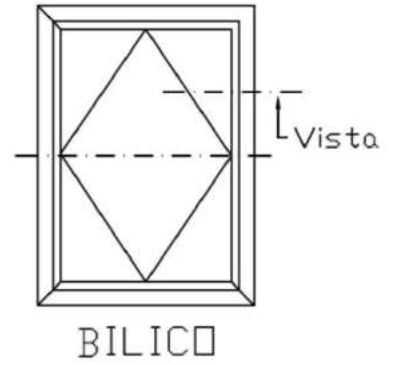

SOLO PARTE LEGNO

			Sistema <b>ASTRO 6</b> 06S
	Cliente Standard		Scala Disegno 1:1
			Tolleranze Generali $\pm 0,5$ mm
Descrizione: <b>SEZIONE ORIZZONTALE MONTANTE BILICO ORIZZONTALE SOPRA CERNIERA</b>			PAGINA
Mod_35_REV01			

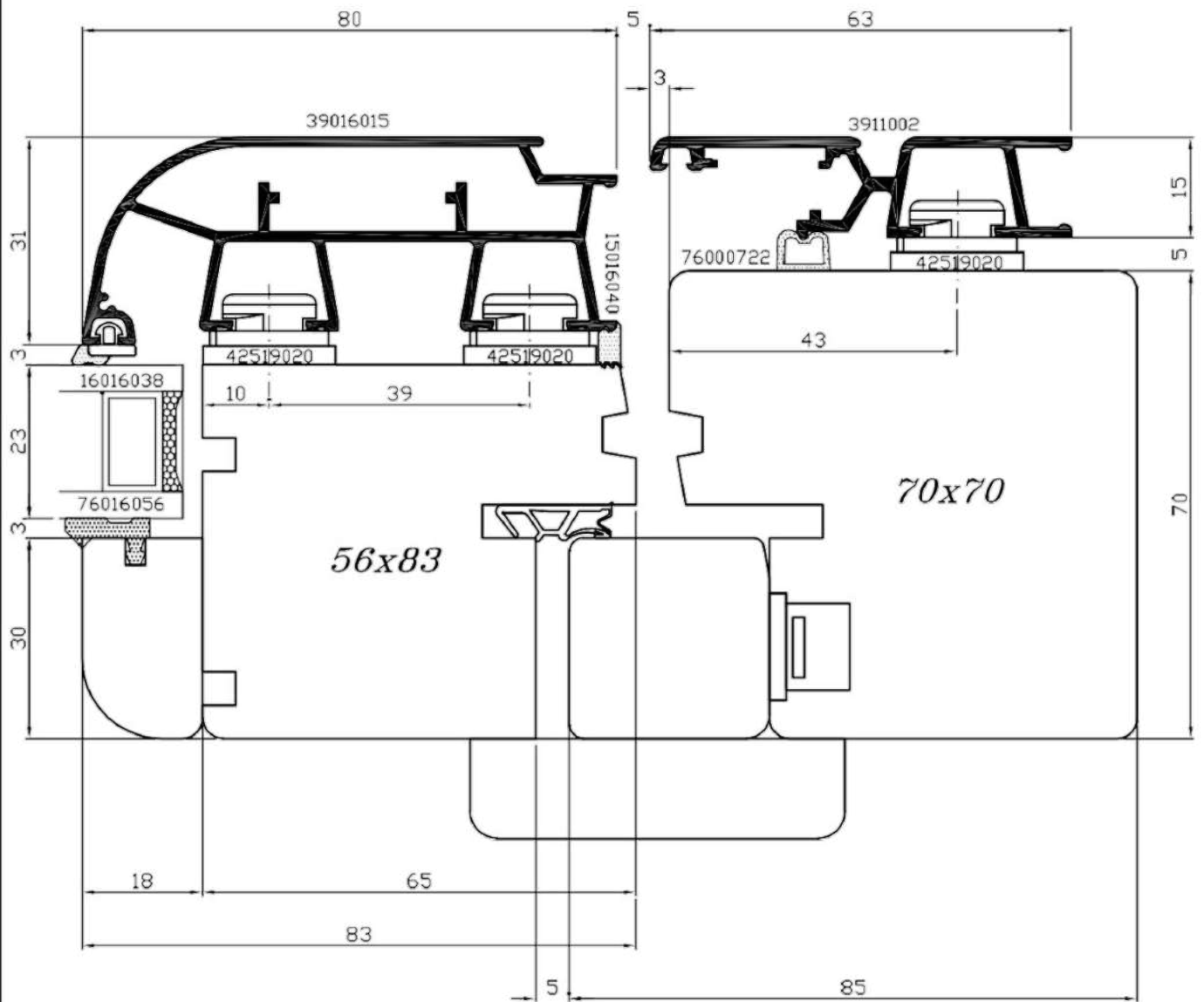
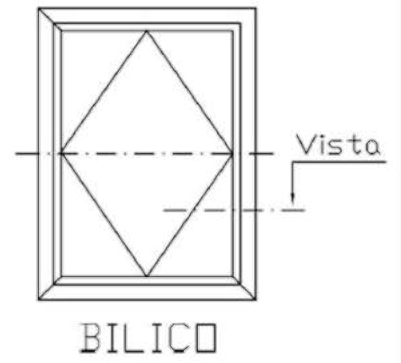

			Sistema <b>ASTRO 6</b> 06S
	Cliente Standard		Scala Disegno 1:1
			Tolleranze Generali ± 0,5 mm
Descrizione: <b>SEZIONE ORIZZONTALE MONTANTE BILICO ORIZZONTALE SOTTO CERNIERA</b>			PAGNIA
Mod_35_REV01			

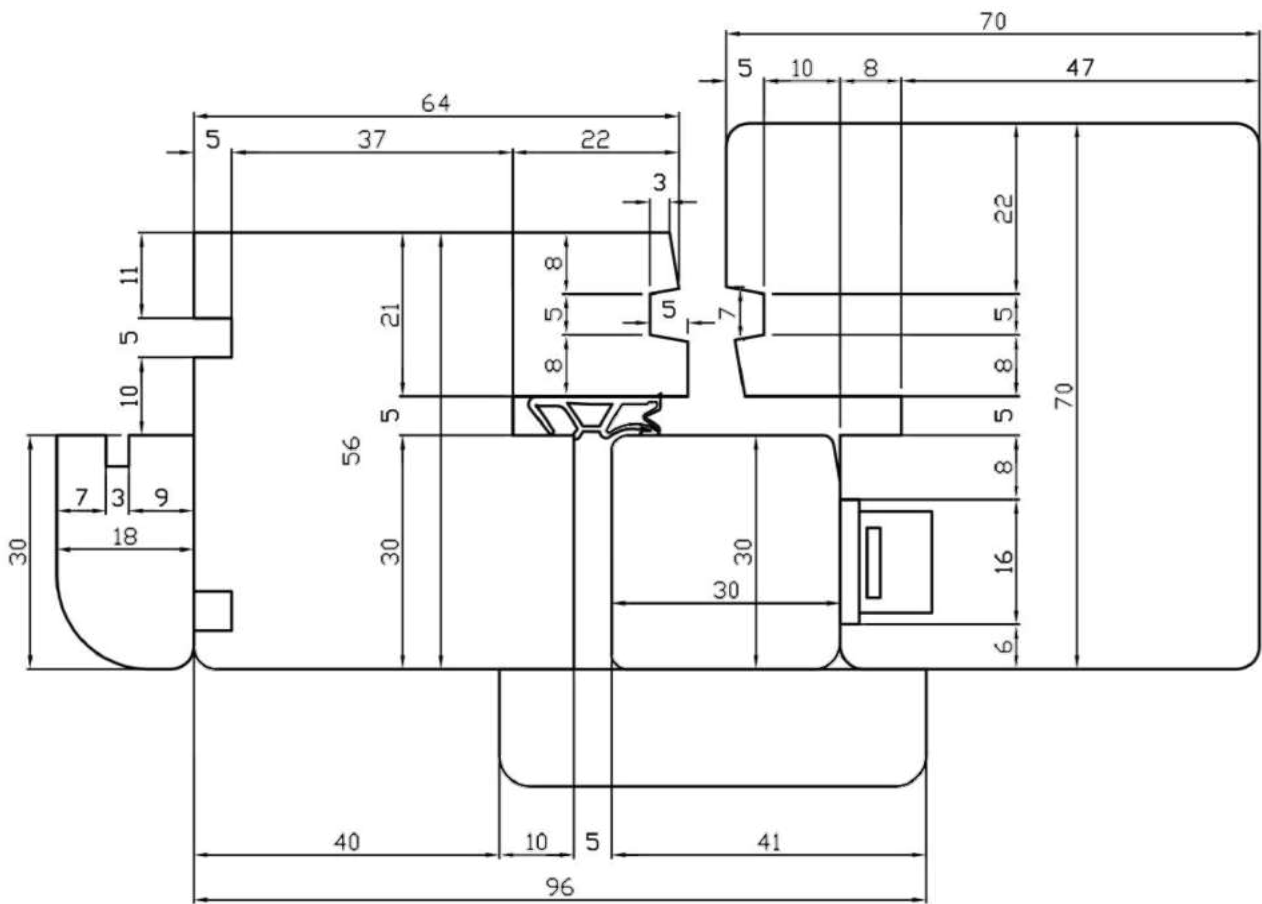
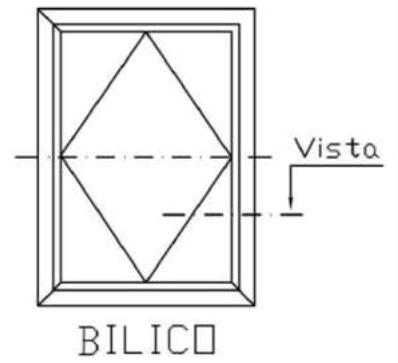

SOLO PARTE LEGNO

			Sistema <b>ASTRO 6</b>	06S
	Cliente Standard		Scala Disegno	1:1
			Tolleranze Generali	± 0,5 mm
Descrizione: <b>SEZIONE ORIZZONTALE MONTANTE BILICO ORIZZONTALE SOTTO CERNIERA</b>			PAGINA	
Mod_35_REV01				



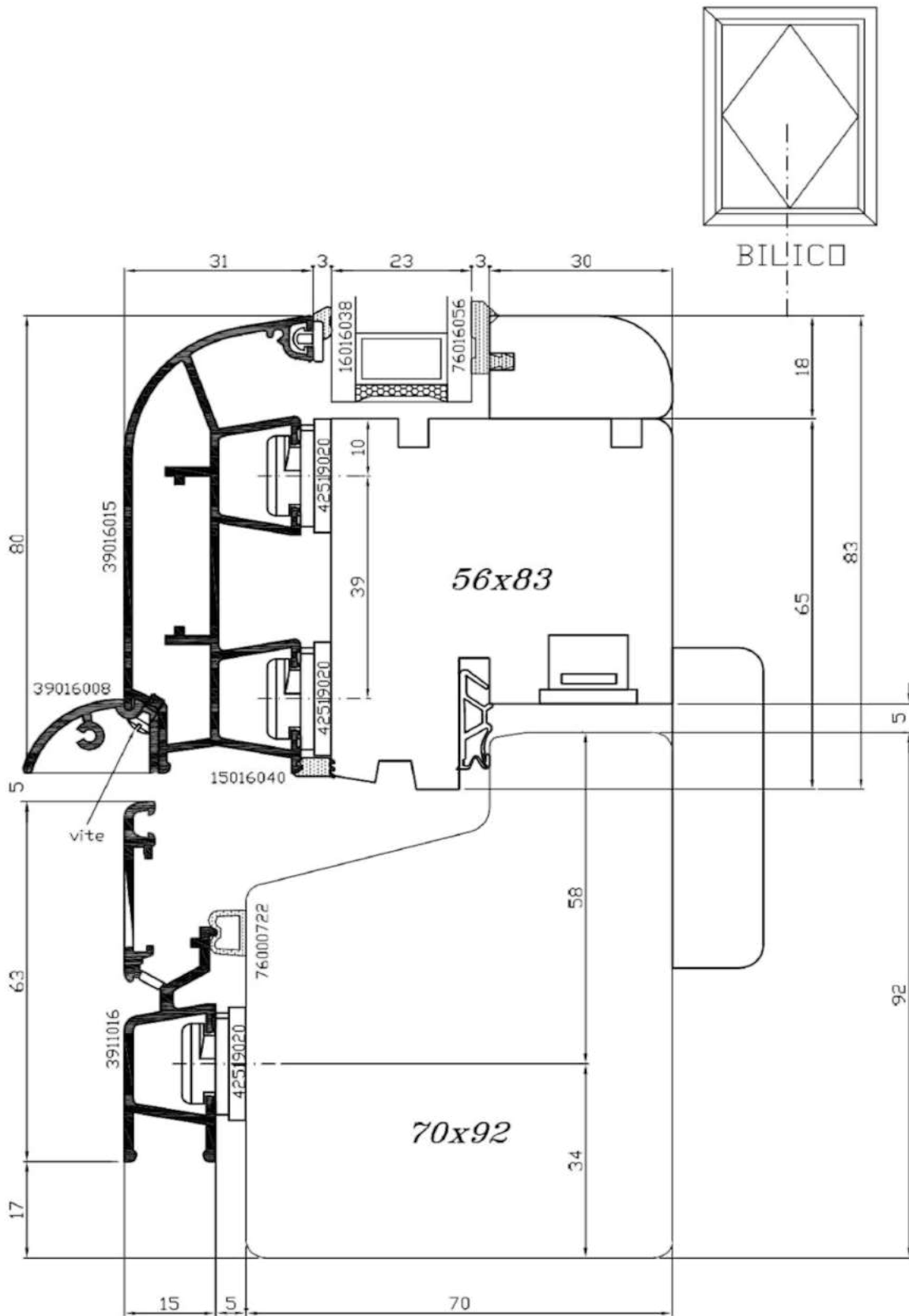

Disegnatore : M.B. Data Emissione 04/03/2005

Approvato da : M.B. Cliente Standard



File:06s319\_050304

REV. 04

Sistema **ASTRO 6** 06S

Scala Disegno 1:1

Tolleranze Generali  $\pm 0,5$  mm

Descrizione: **SEZIONE VERTICALE TRAVERSO  
BILICO ORIZZONTALE INFERIORE**

PAGINA

**322**

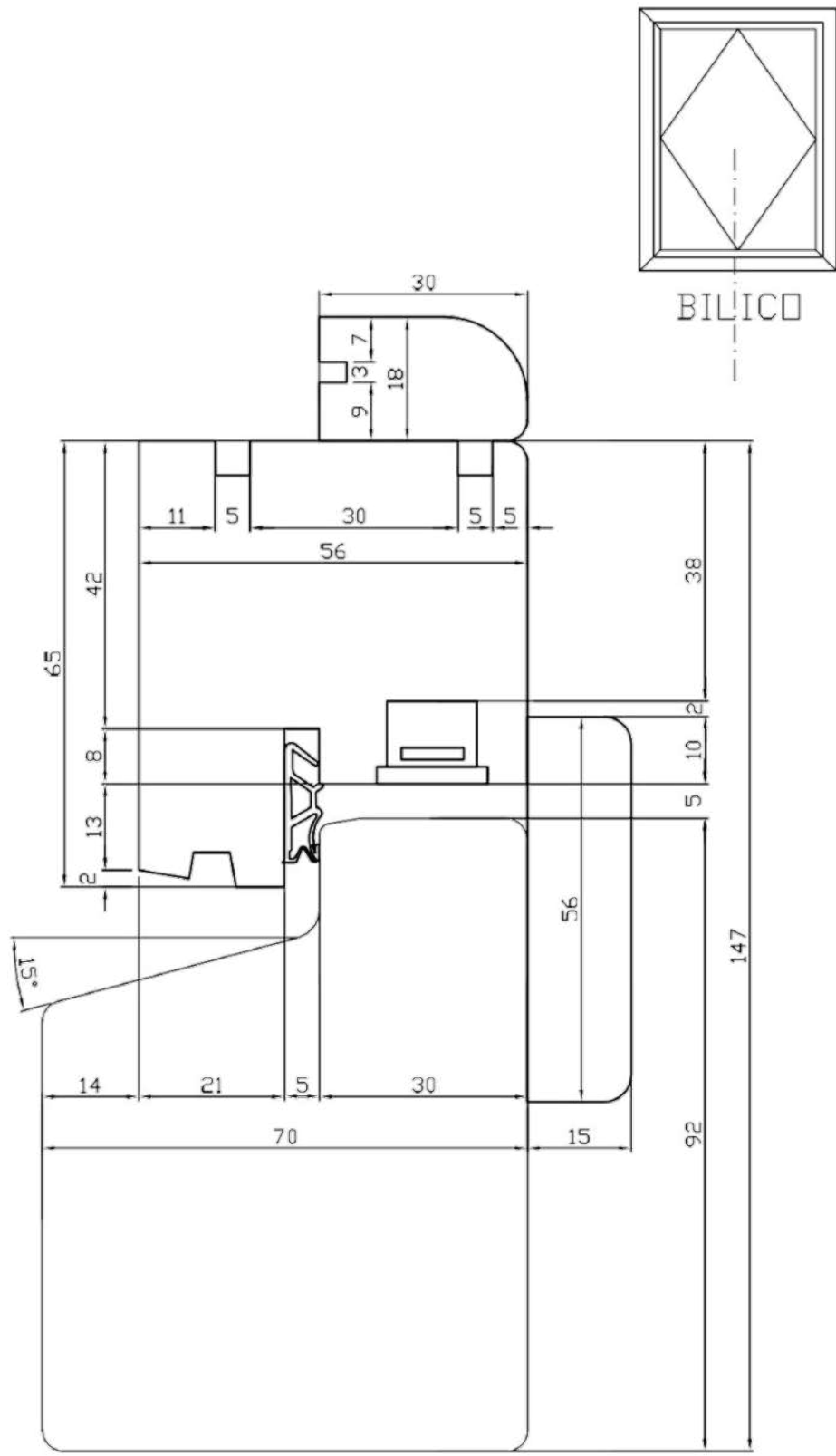

SOLO PARTE LEGNO

			Sistema <b>ASTRO 6</b> 06S
	Cliente Standard		Scala Disegno 1:1
			Tolleranze Generali ± 0,5 mm
Descrizione: <b>SEZIONE VERTICALE TRAVERSO BILICO ORIZZONTALE INFERIORE</b>			PAGINA <b>322L</b>
Mod_35_REV01			

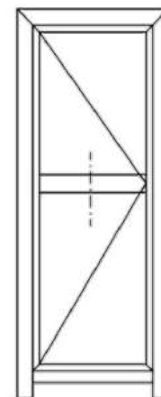

PF1A\_ta

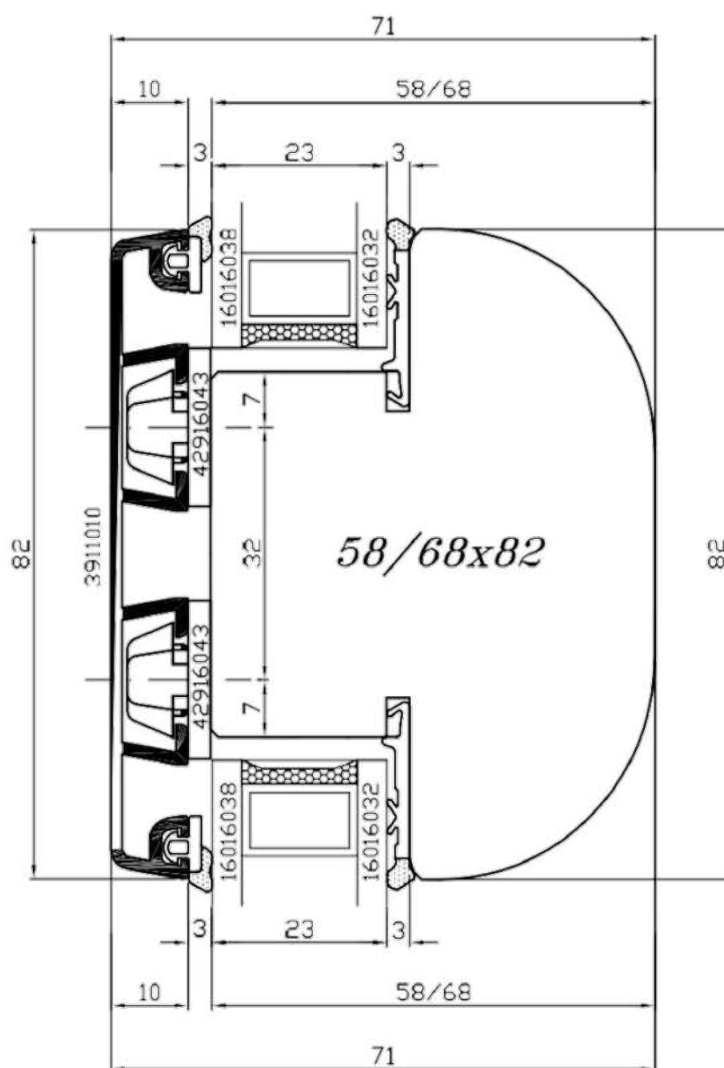
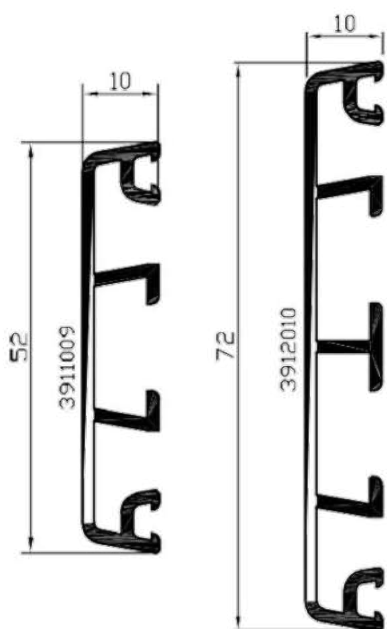

			Sistema <b>ASTRO 6</b> 06S
	Cliente Standard		Scala Disegno 1:1
			Tolleranze Generali ± 0,5 mm
Descrizione: <b>SEZIONE VERTICALE TRAVERSO CENTRALE PORTAFINESTRA</b>			
Mod_35_REV01			

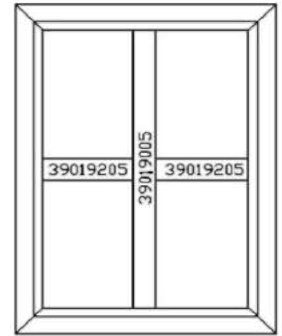
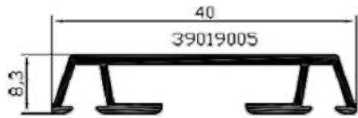

F1A

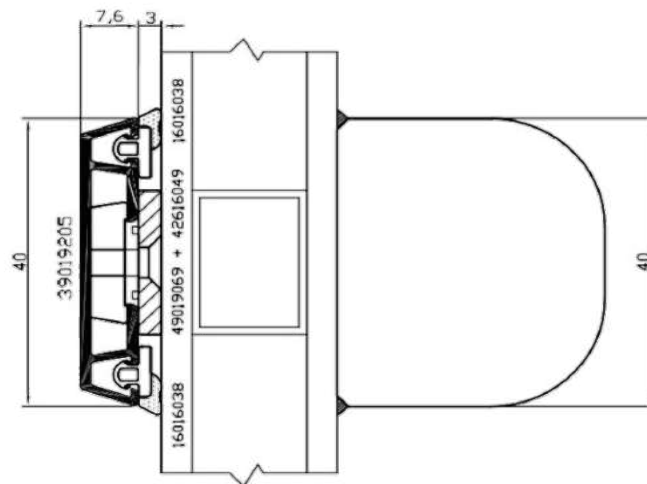
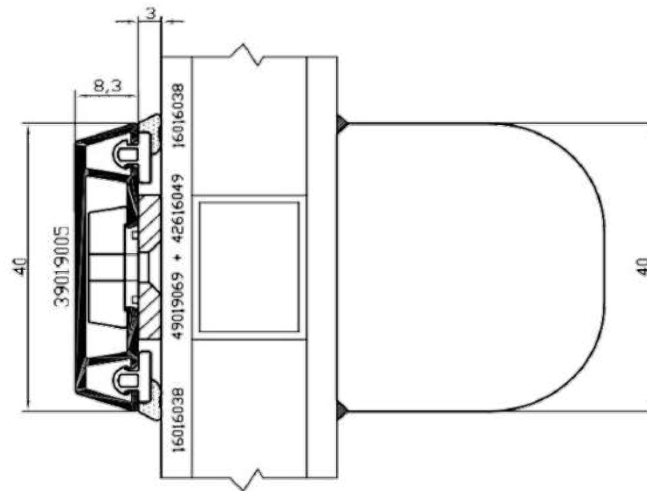

ATTENZIONE: I profile inglesina possono essere applicate solate sul profile ante astro 6

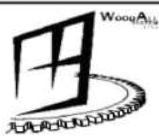
			Sistema <b>ASTRO 6</b>	09S
	Cliente Standard		Scala Disegno	1:1
			Tolleranze Generali	± 0,5 mm
Descrizione: <b>SEZIONE VERTICALE INGLESINA</b>			<b>PAGINA</b>	
Mod_35_REV01				

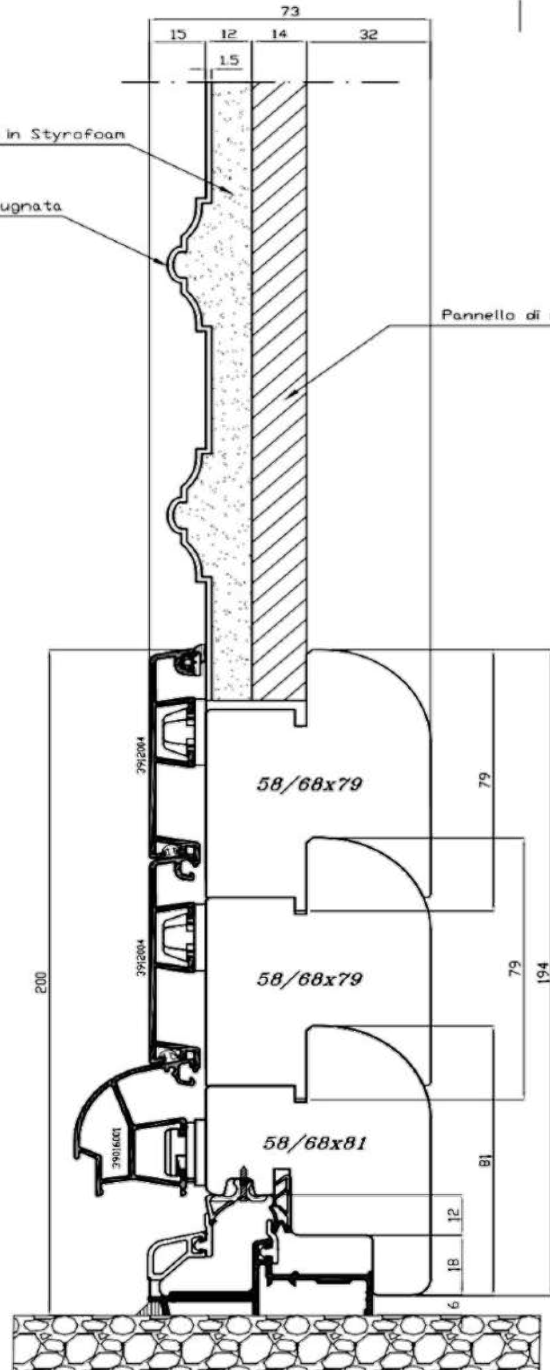
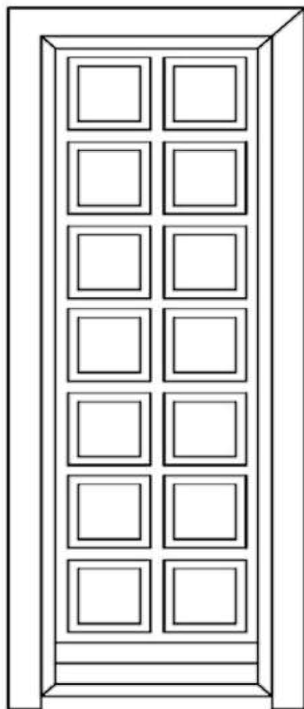
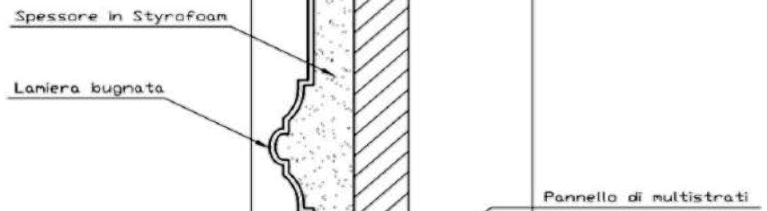
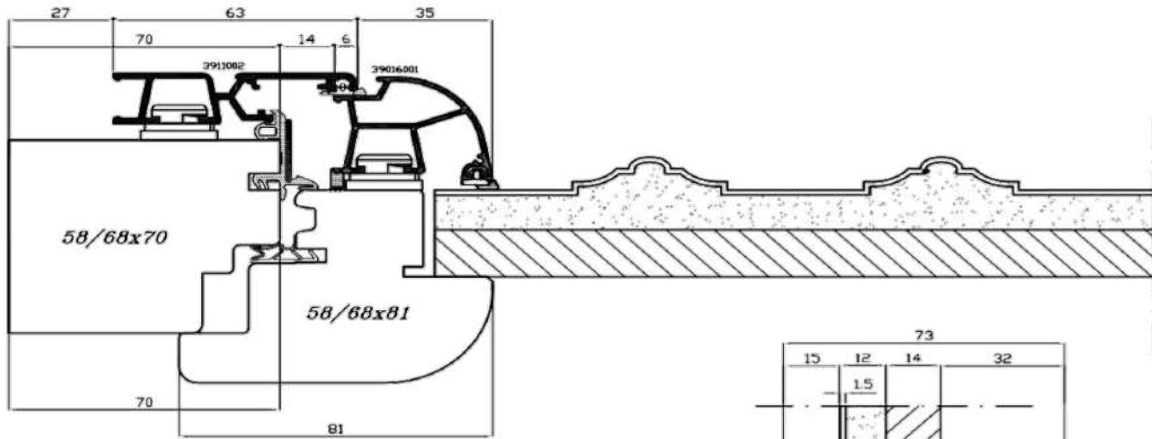

			Sistema <b>ASTRO 6</b> 06S
	Cliente Standard		Scala Disegno Fuori Scala
			Tolleranze Generali $\pm 0,5$ mm
Descrizione:	<b>MONTAGGIO PANNELLO BUGNATO</b>		PAGINA
Mod_35_REV01			

Profilo guida persiana

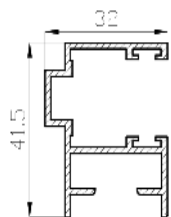

39001990

Profilo montante centrale

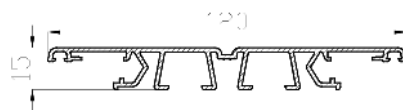

39011057

Profilo telaio corto



39011002

Profilo zoccolo

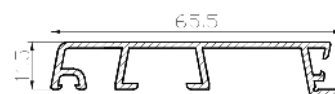

39012004

Profilo zoccolo largo

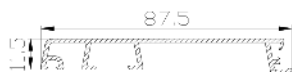

39011004

Profilo anta

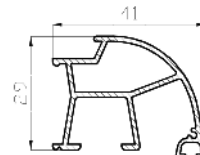

39016001

Profilo trasverso centrale

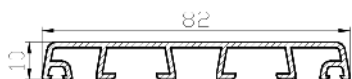

39011010

Profilo telaio

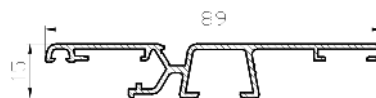

39016002

Cliente Standard



Sistema Astro 6 06S

Scala Disegno 1:1

Tolleranze Generali  $\pm 0,5$  mm

Descrizione:

**PROFILI DI ALLUMINIO**

PAGINA



Profilo Montantino

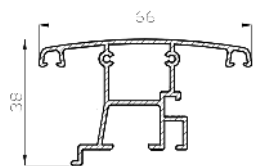

39016003

Profilo Montantino

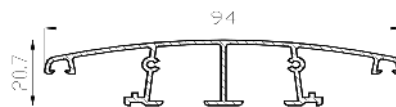

39016005

Profilo Anta Larga

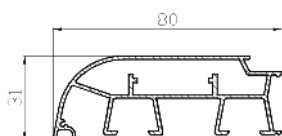

39016015

Profilo Telaio Forato

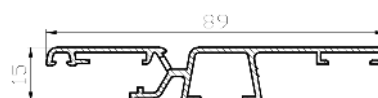

39016016

Profilo Anta Maggiorata

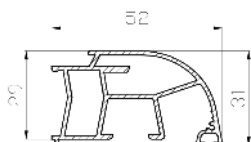

39016311

			Sistema Astro 6	06S
	Cliente Standard		Scala Disegno	1:1
			Tolleranze Generali	---
Descrizione: <b>PROFILI DI ALLUMINIO</b>			PAGINA	
Mod_35_REV01				

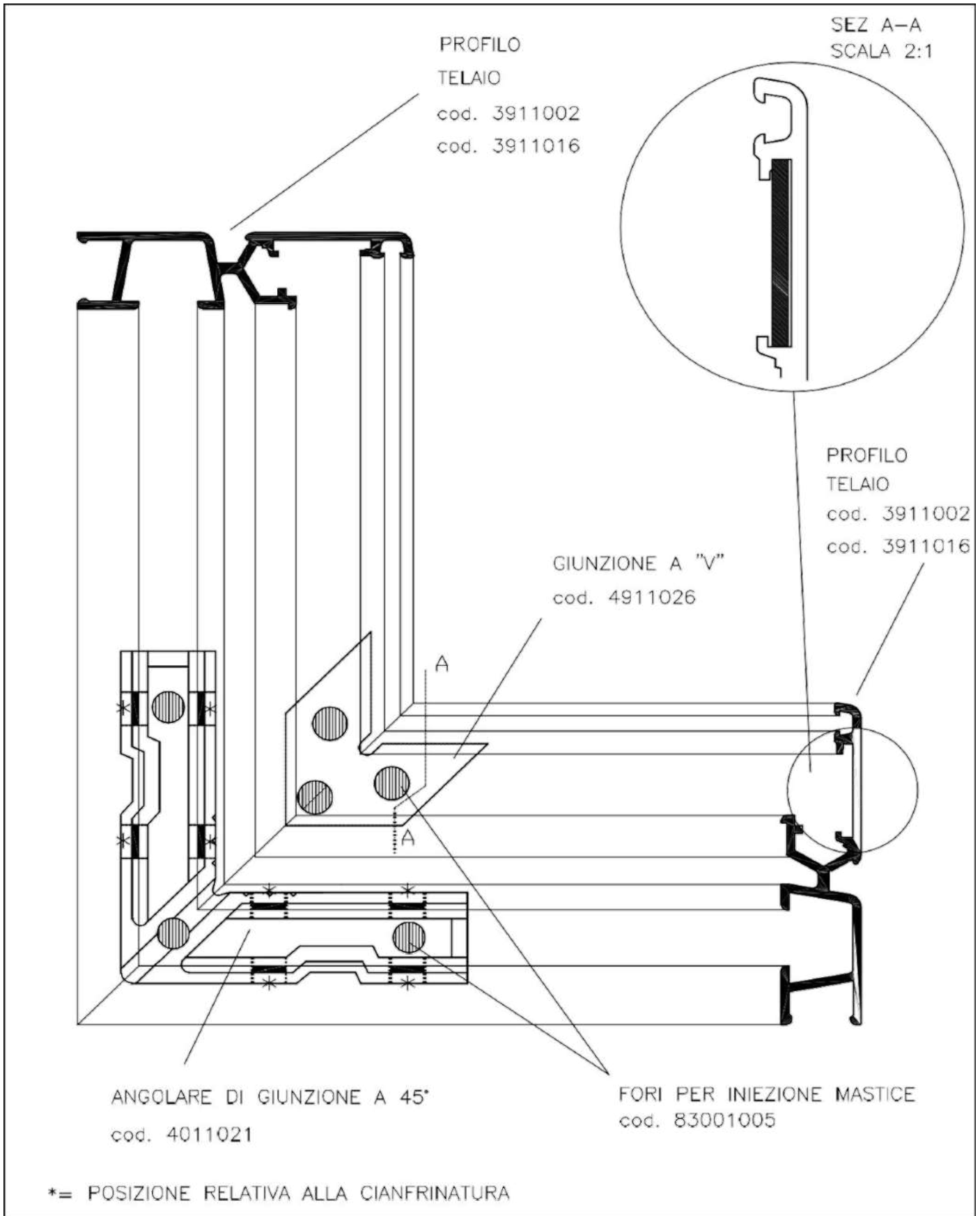

			Sistema Astro 6	06S
	Cliente Standard		Scala Disegno	1:1
			Tolleranze Generali	---
Descrizione: <b>UNIONE PROFILO TELAIO</b>			PAGINA <b>800</b>	
Mod_35_REV01				

PROFILO  
TELAIO  
cod. 3911002  
cod. 3911016

SEZ A-A  
SCALA 2:1

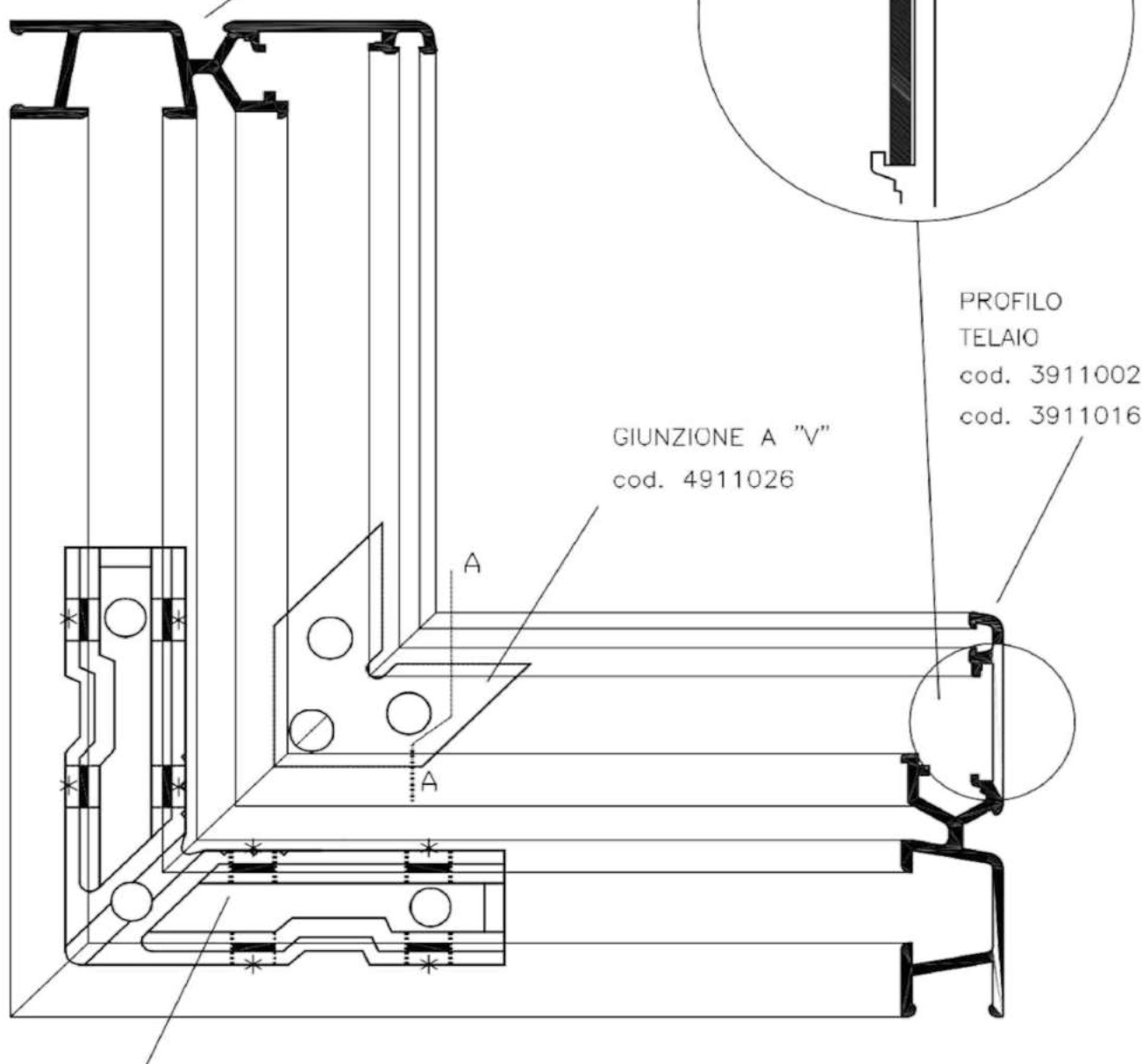

GIUNZIONE A "V"  
cod. 4911026

PROFILO  
TELAIO  
cod. 3911002  
cod. 3911016

ANGOLARE DI GIUNZIONE A 45°  
cod. 4011021

\*= POSIZIONE RELATIVA ALLA CIANFRINATURA

Disegnatore : L.F.	Data Emissione 08/04/2006		File:06s800_060408	Sistema Astro 6	06S
Approvato da : G.N.	Cliente Standard		REV. 05	Scala Disegno	1:1
Descrizione:				Tolleranze Generali	± 0,5 mm
<b>UNIONE PROFILI TELAIO</b>				<b>PAGINA</b>	<b>800</b>

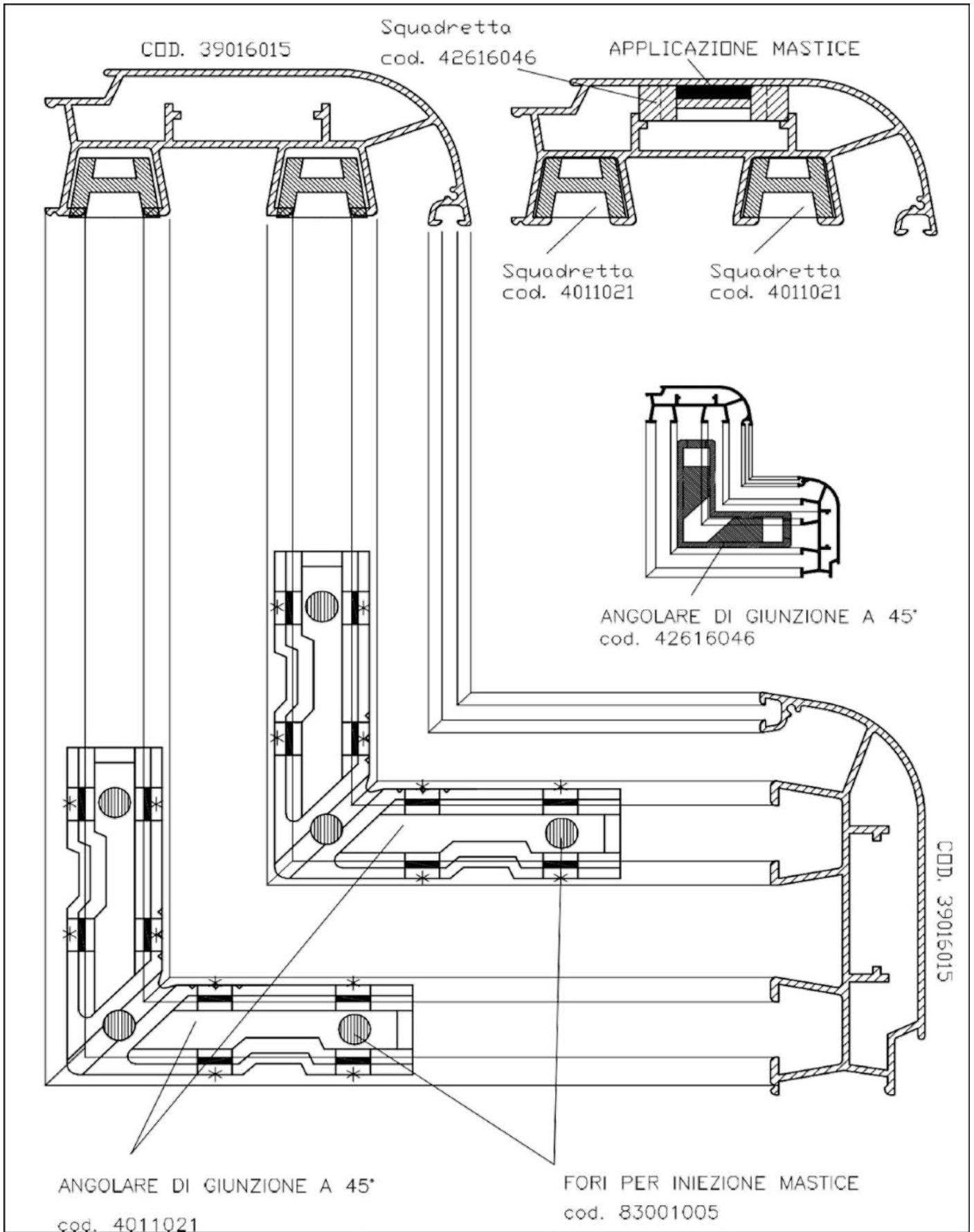

Disegnatore : L.F.		File:06s801_041227	Sistema Astro 6	06S
Approvato da : G.N. Cliente Standard		REV. 01	Scala Disegno	1:1
Descrizione: <b>UNIONE PROFILO TELAIO</b>			Tolleranze Generali	---
			FACINA	<b>801</b>
Mod_35_REV01				

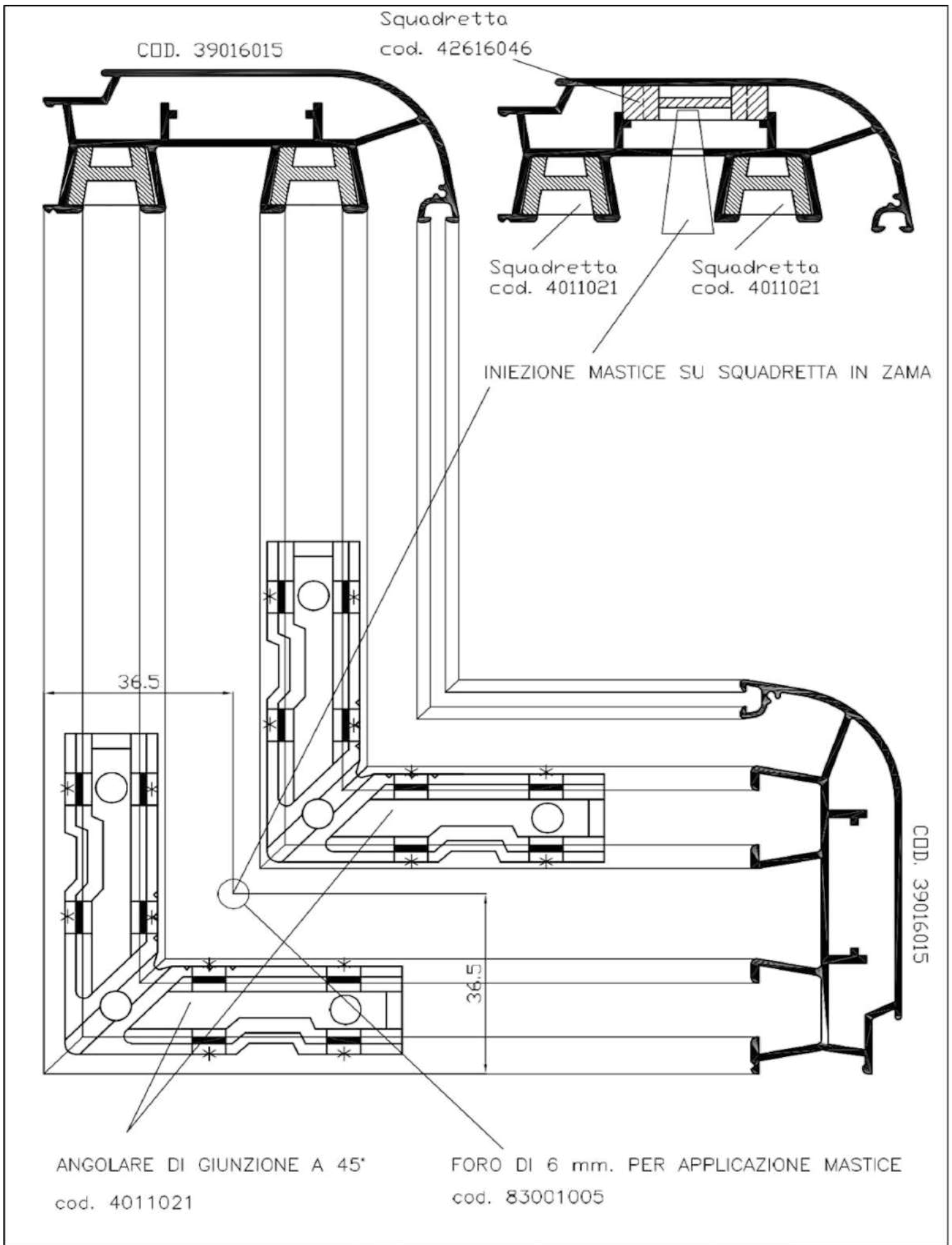

Disegnatore : L.F.	Data Emissione 08/04/2006		File:06s801_060408	Sistema Astro 6	06S
Approvato da : G.N.	Cliente Standard		REV. 05	Scala Disegno	1:1
Descrizione: <b>UNIONE PROFILI ANTA LARGA</b>				Tolleranze Generali	± 0,5 mm
				PAGINA	<b>801</b>



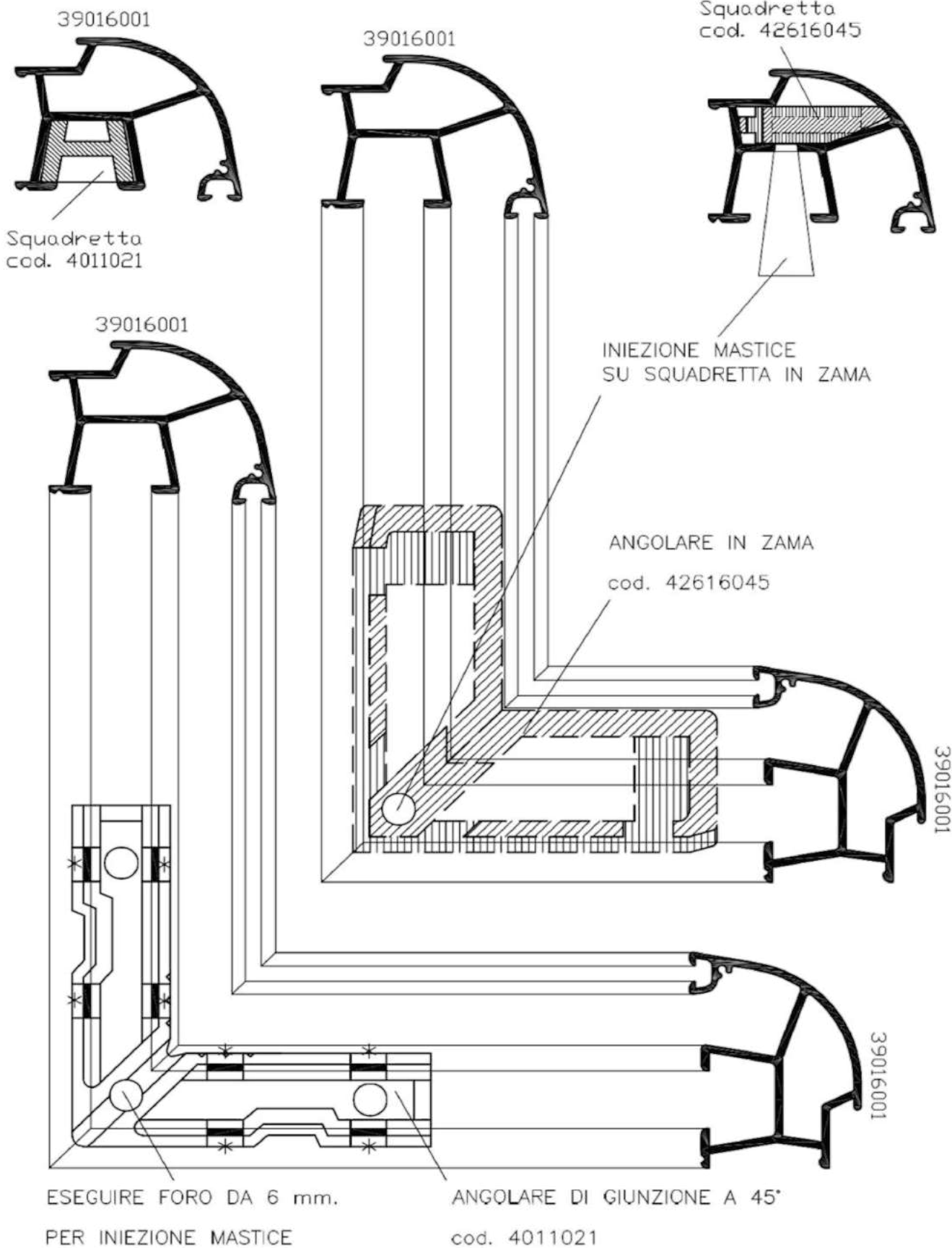

Disegnatore : L.F.	Data Emissione 27/12/2004		File:06s802_041227	Sistema Astro 6	06S
Approvato da : G.N.	Cliente Standard		REV. 01	Scala Disegno	1:1
Descrizione: <h2 style="text-align: center;">UNIONE PROFILO ANTA</h2>				Tolleranze Generali	---
				PAGINA	802



39016001

TASSELLI  
cod. 4011025

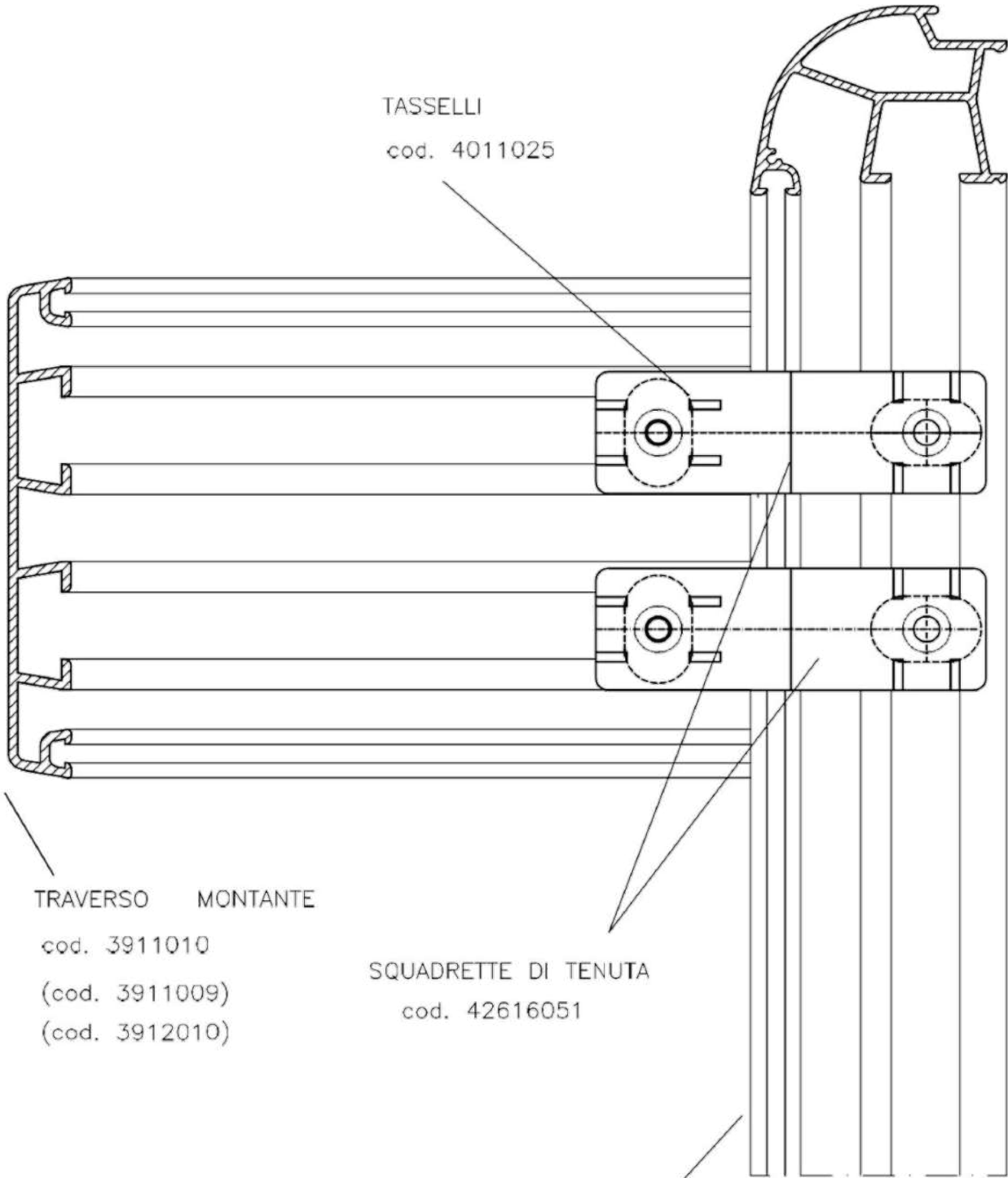

TRAVERSO MONTANTE  
cod. 3911010  
(cod. 3911009)  
(cod. 3912010)

SQUADRETTE DI TENUTA  
cod. 42616051

PROFILO ANTA  
cod. 39016001 o 39016015

			Sistema Astro 6	06S	
	Cliente Standard			Scala Disegno	1:1
				Tolleranze Generali	---
Descrizione:			FACINA		
<b>MONTAGGIO</b>			<b>803</b>		
Mod_35_REV01					

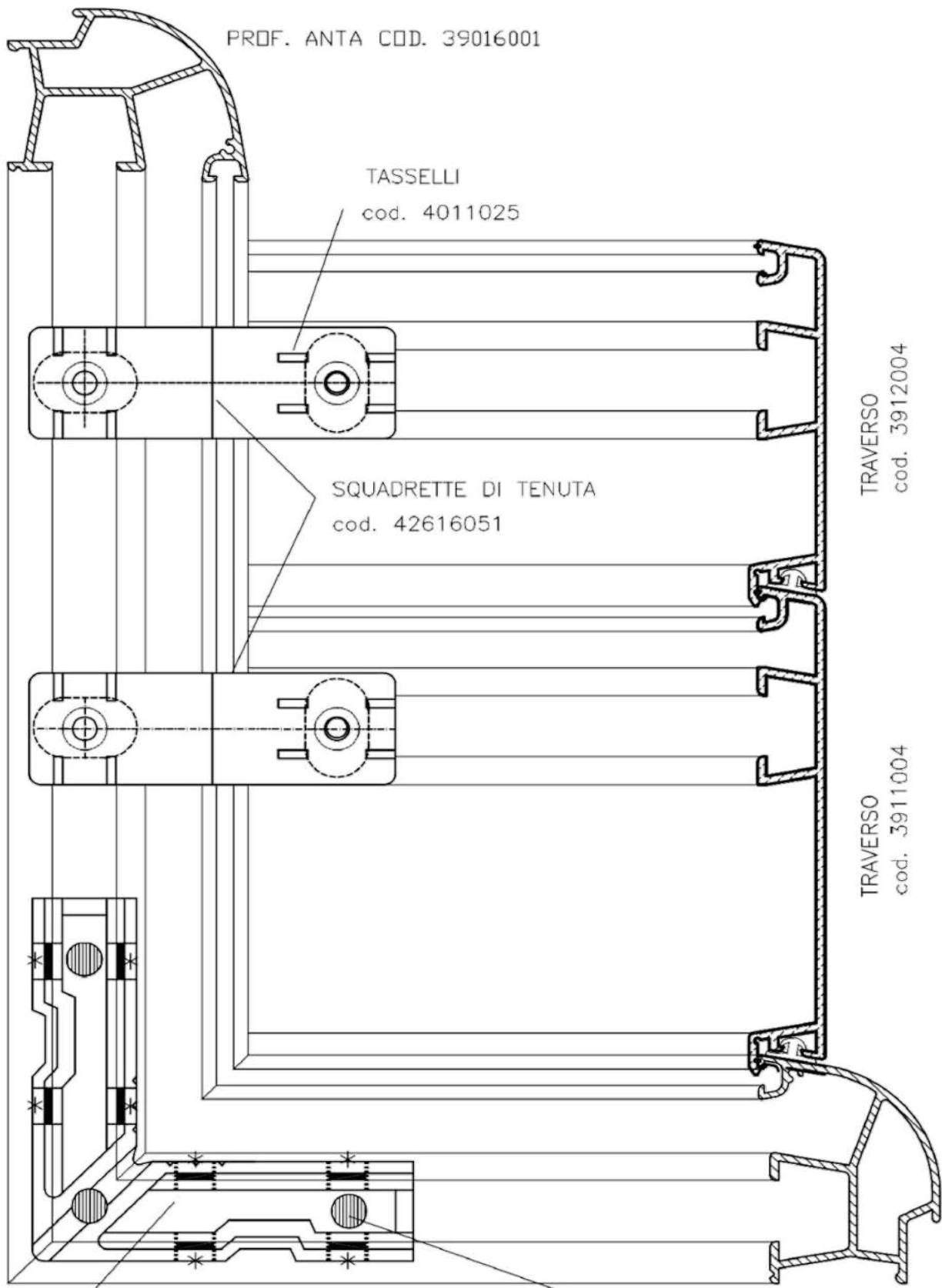

PROF. ANTA COD. 39016001

TASSELLI  
cod. 4011025

SQUADRETTE DI TENUTA  
cod. 42616051

TRAVERSO  
cod. 3912004

TRAVERSO  
cod. 3911004

PROF. ANTA COD. 39016001

ANGOLARE DI GIUNZIONE A  
cod. 4011021

FORI PER INIEZIONE MASTICE  
cod. 83001005

	Cliente Standard		Sistema Astro 6	06S	
				Scala Disegno	1:1
				Tolleranze Generali	---
Descrizione: <b>UNIONE PROFILO ZOCCOLO SU ANTA</b>			PAGINA <b>804</b>		

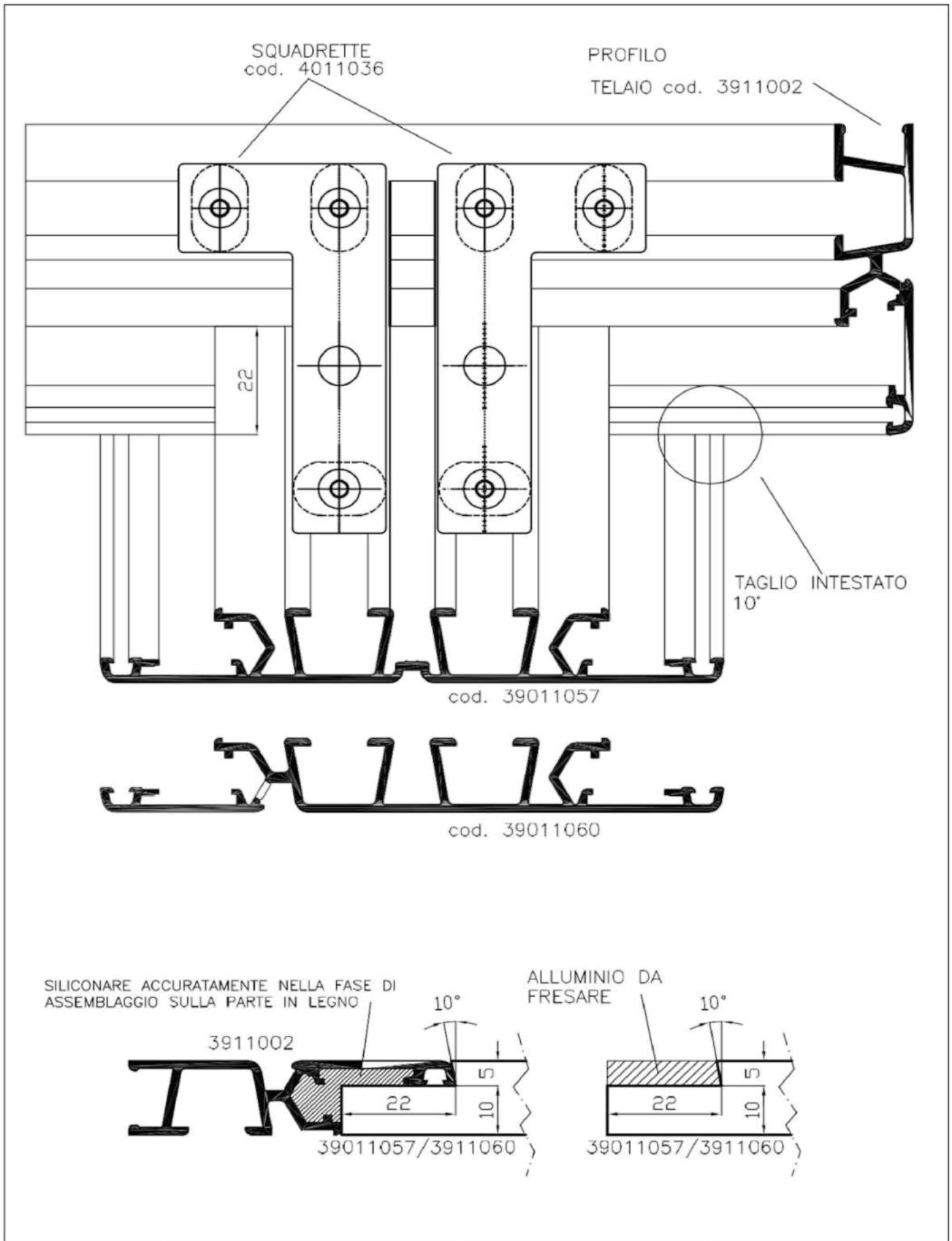



Disegnatore : L.F.	Data Emissione 08/04/2006		File:06s805_060408	Sistema Astro 6	06S
Approvato da : G.N.	Cliente Standard		REV. 05	Scala Disegno	1:1
Descrizione:				Tolleranze Generali	± 0,5 mm
<p align="center"><b>ESEMPIO DI MONTAGGIO</b></p>				PAGINA	<b>805</b>
Mod_35_REV01					

# MONTAGGIO IN LUCE

## FASI DI MONTAGGIO

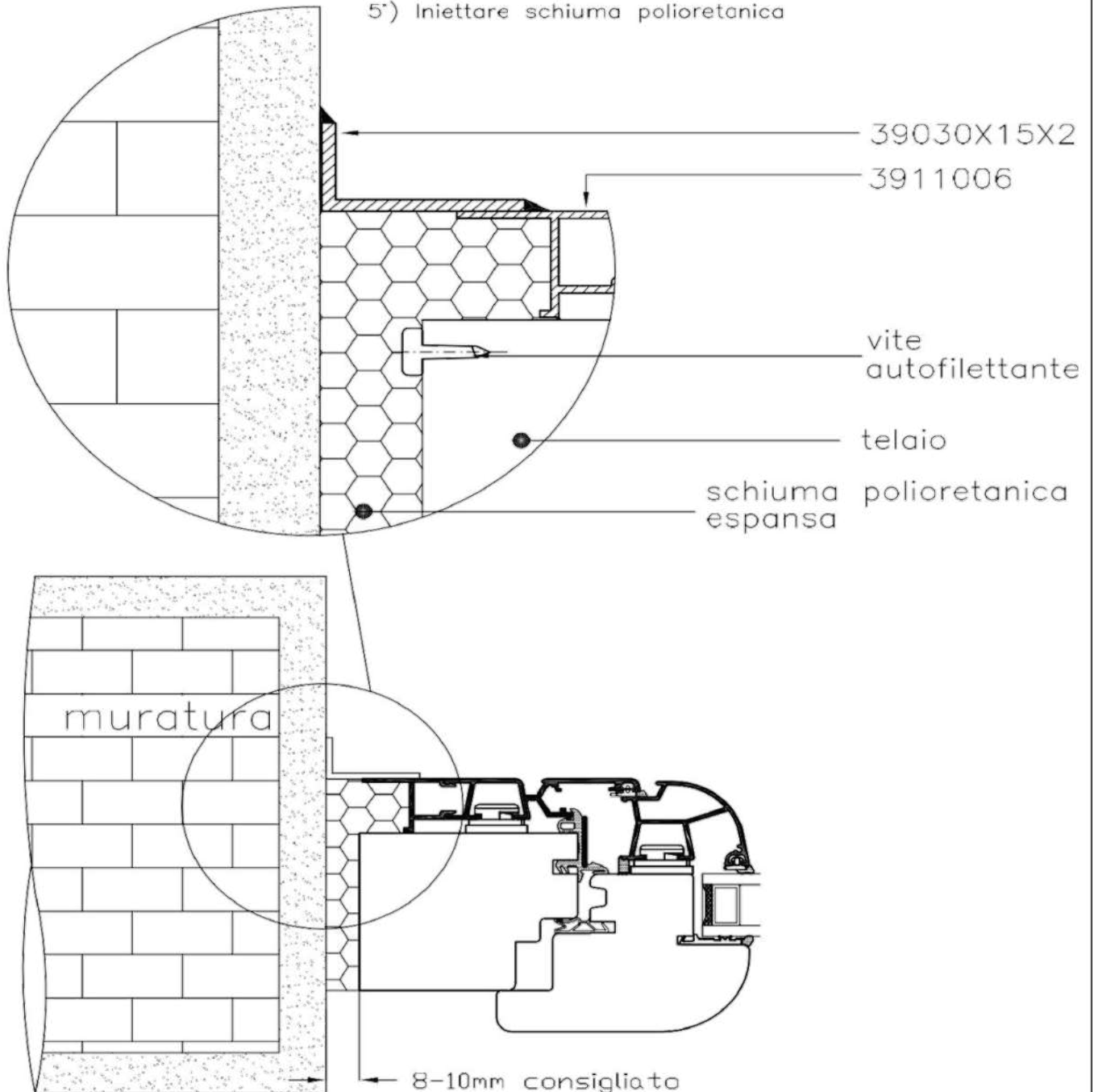
- 1') Pulizia sia della parte in muratura sia dell'infisso
- 2') Eseguire un filo di silicone sul davanzale
- 3') Fissare la finestra
- 4') fissare angolare e siliconare
- 5') Iniettare schiuma poliuretanic



			Sistema Astro 6	06S
	Cliente Standard		Scala Disegno	---
			Tolleranze Generali	---
Descrizione:	<b>ESEMPI DI MONTAGGIO</b>			PAGINA

# MONTAGGIO IN MAZZETTA

## FASI DI MONTAGGIO

- 1\*) Pulizia sia del controtelaio sia dell'infisso
- 2\*) Eseguire un filo di silicone su 4 lati
- 3\*) Fissare la finestra
- 4\*) Iniettare schiuma poliuretanicca

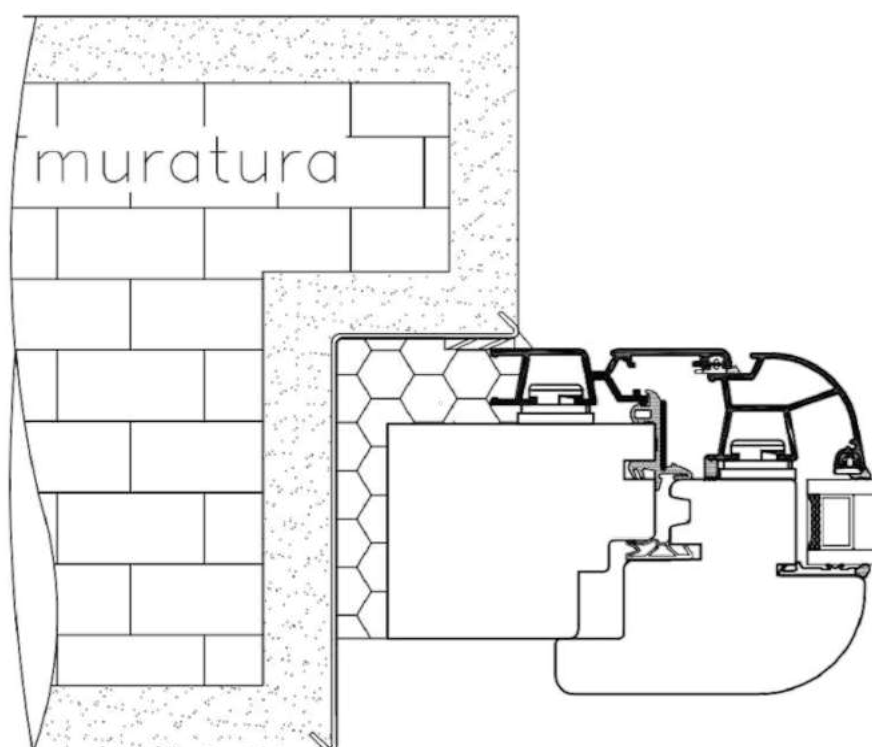
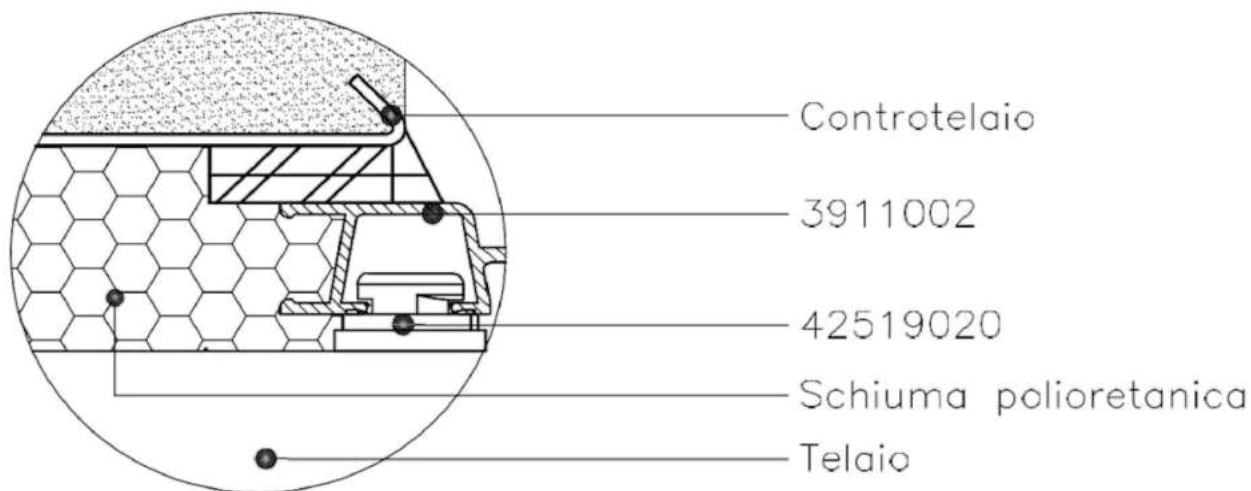

			Sistema Astro 6	06S
			Scala Disegno	---
			Tolleranze Generali	---
Descrizione:	<b>ESEMPI DI MONTAGGIO</b>			PAGINA

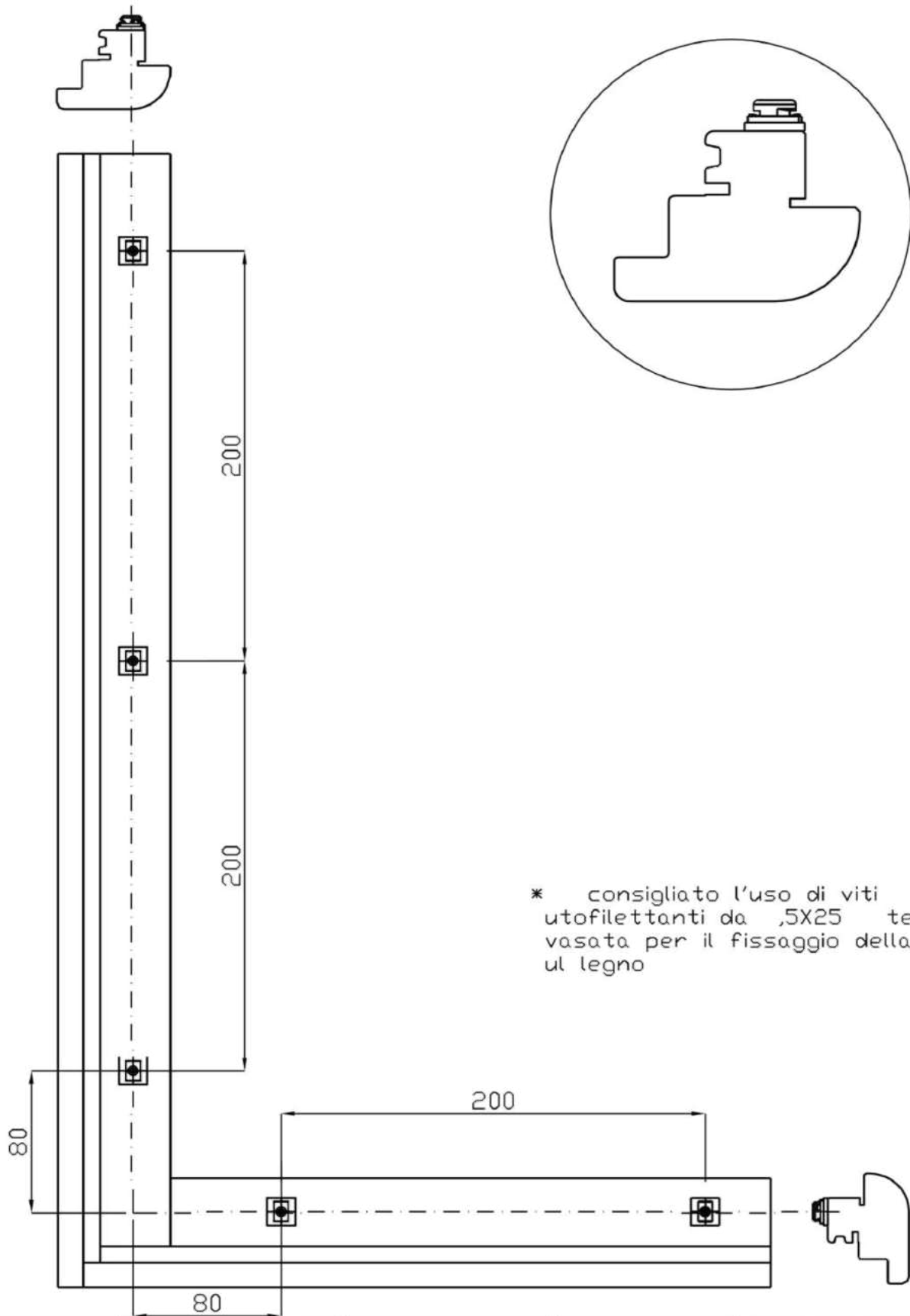

Disegnatore : L.F.	Data Emissione 17/02/2005		File:06s812_050217	Sistema Astro G	06S
Approvato da : G.N.	Cliente Standard		REV. 04	Scala Disegno	Fuori Scala
				Tolleranze Generali	---
Descrizione: <b>DISPOSIZIONE MONTAGGIO CLIPS COD.42519020</b>				PAGINA	<b>812</b>
Mod_35_REV01					



ATTENZIONE:  
 FISSARE TRAMITE CLIPS  
 COD.4011020 IL PROF. COD.  
 39016003  
 DOPO AVER FISSATO IL  
 PROF. ANTA  
 COD. 39016001

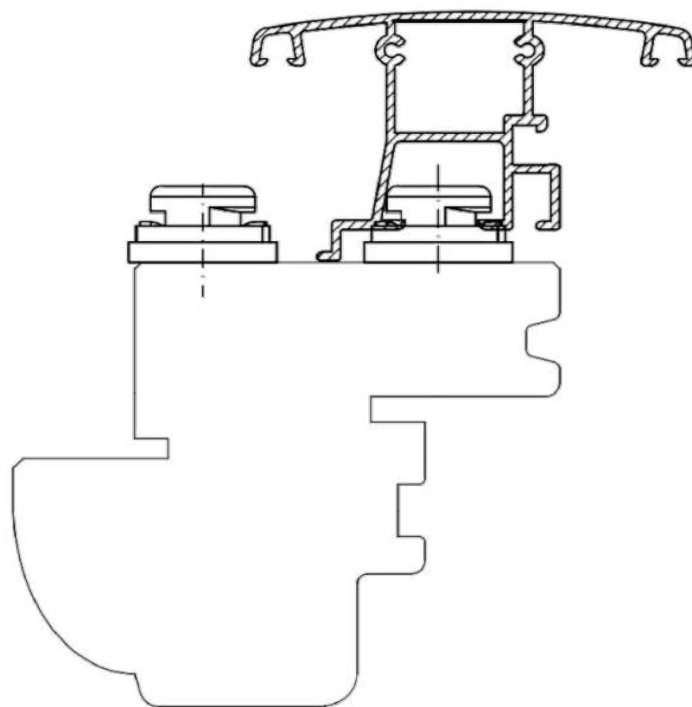
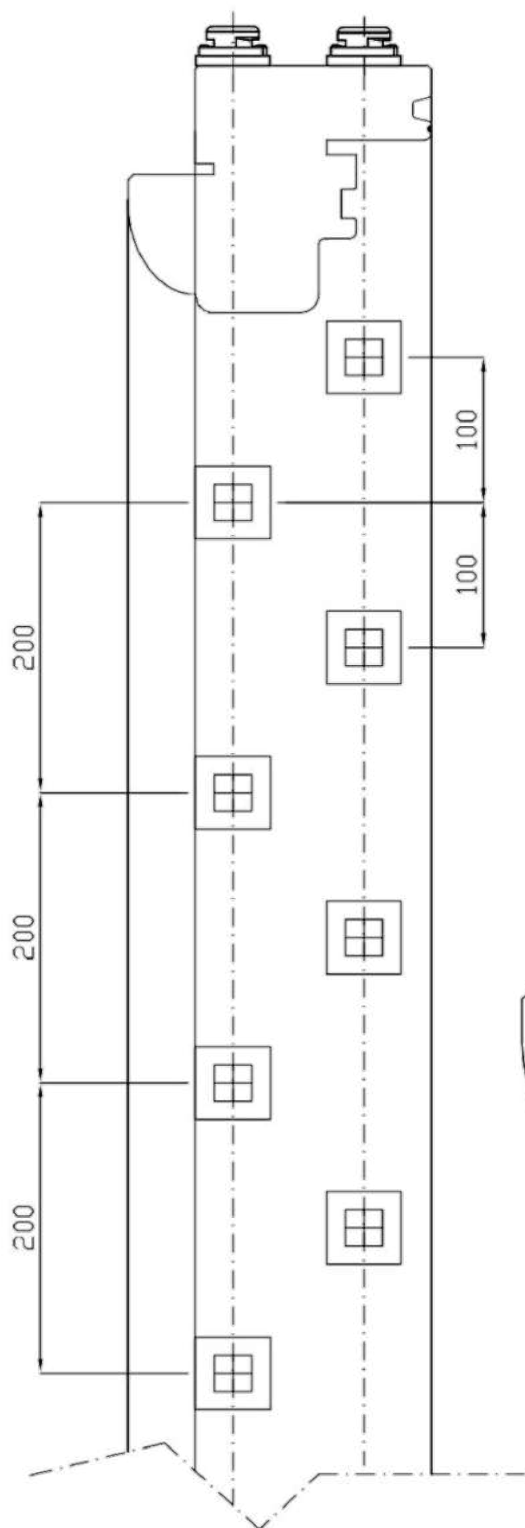

\* consigliato l'uso di viti  
 autofilettanti da 3,5X25 a testa  
 svasata per il fissaggio della clips  
 sul legno

			Sistema Astro 6	06S
	Cliente Standard		Scala Disegno	Fuori Scala
			Tolleranze Generali	---
Descrizione: <b>DISPOSIZIONE MONTAGGIO                  CLIPS SU MONTANTE</b>			PAGINA	<b>813</b>
Mod_35_REV01				

ATTENZIONE:  
 FISSARE TRAMITE CLIPS  
 COD.4011020 IL PROF. COD.  
 39016003  
 DOPO AVER FISSATO IL  
 PROF. ANTA LARGA COD.  
 39016015

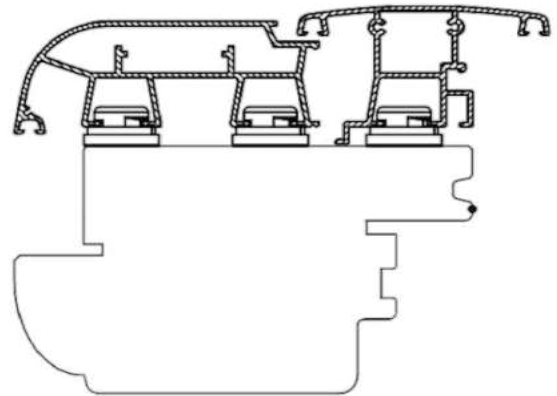
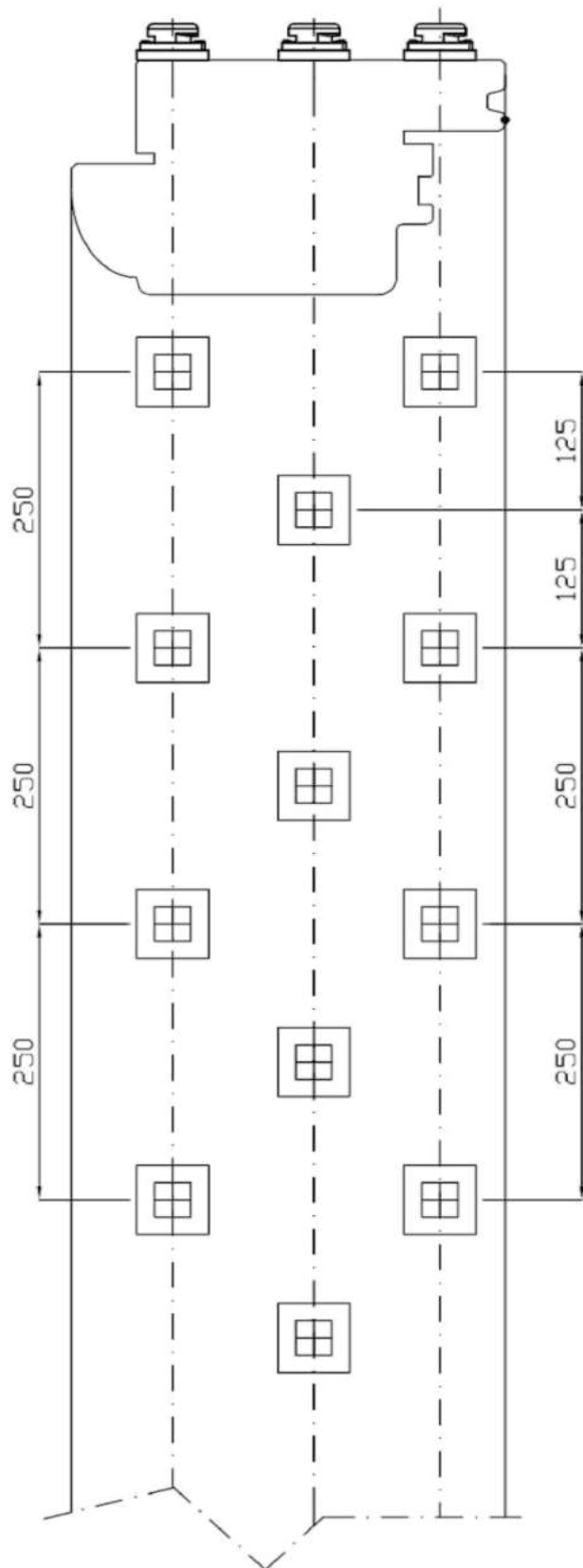

\* è consigliato l'uso di viti  
 autofilettanti da 3,5X25 a testa  
 svasata per il fissaggio della clips  
 sul legno

Disegnatore : L.F. Data Emissione 27/12/2004  
 Approvato da : G.N. Cliente Standard



File:06s813\_041227  
 REV. 01

Sistema Astro 6 06S  
 Scala Disegno Fuori Scala  
 Tolleranze Generali ---

Descrizione: **DISPOSIZIOE MONTAGGIO CLIPS  
 CLIPS SU MONTANTE**

Mod\_35\_REV01

PACINA

**814**



OLTRE  
CIO' CHE VEDI!

# ASTRO 6 - sezioni

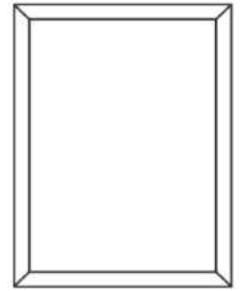

FF

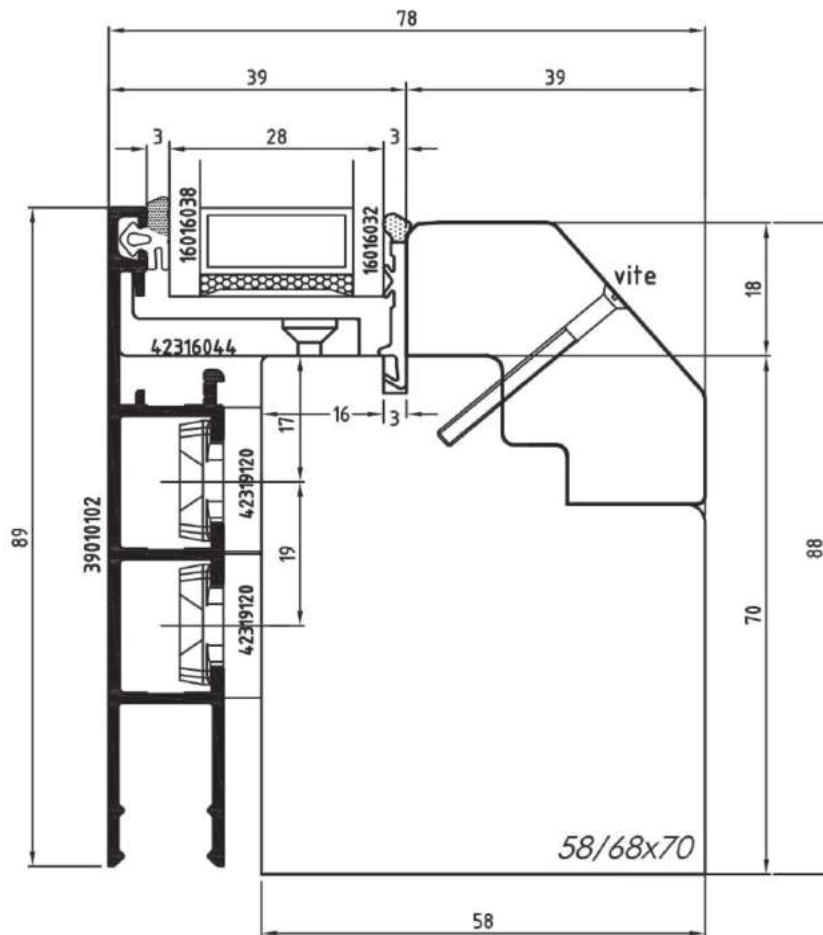

Attenzione: finestra fissa. Fissare con vite su telaio accessorio cod. 42316044 come supporto per profilo 39011002 con interasse 150mm

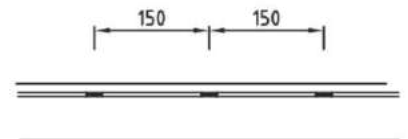

Sistema:  
**ASTRO 6 DIAMANTE**

Scala:  
1:1

Tavola:  
301

Descrizione :  
SEZIONE VERTICALE VETRO FISSO

Nome File:  
ASTRO 6\_Diamante rev.01

n° Pagina

# ASTRO 6 - sezioni

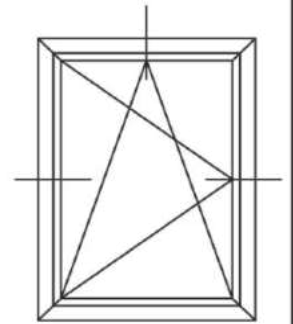

F1A

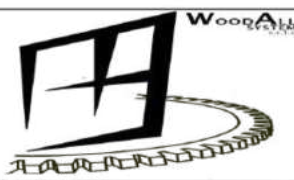
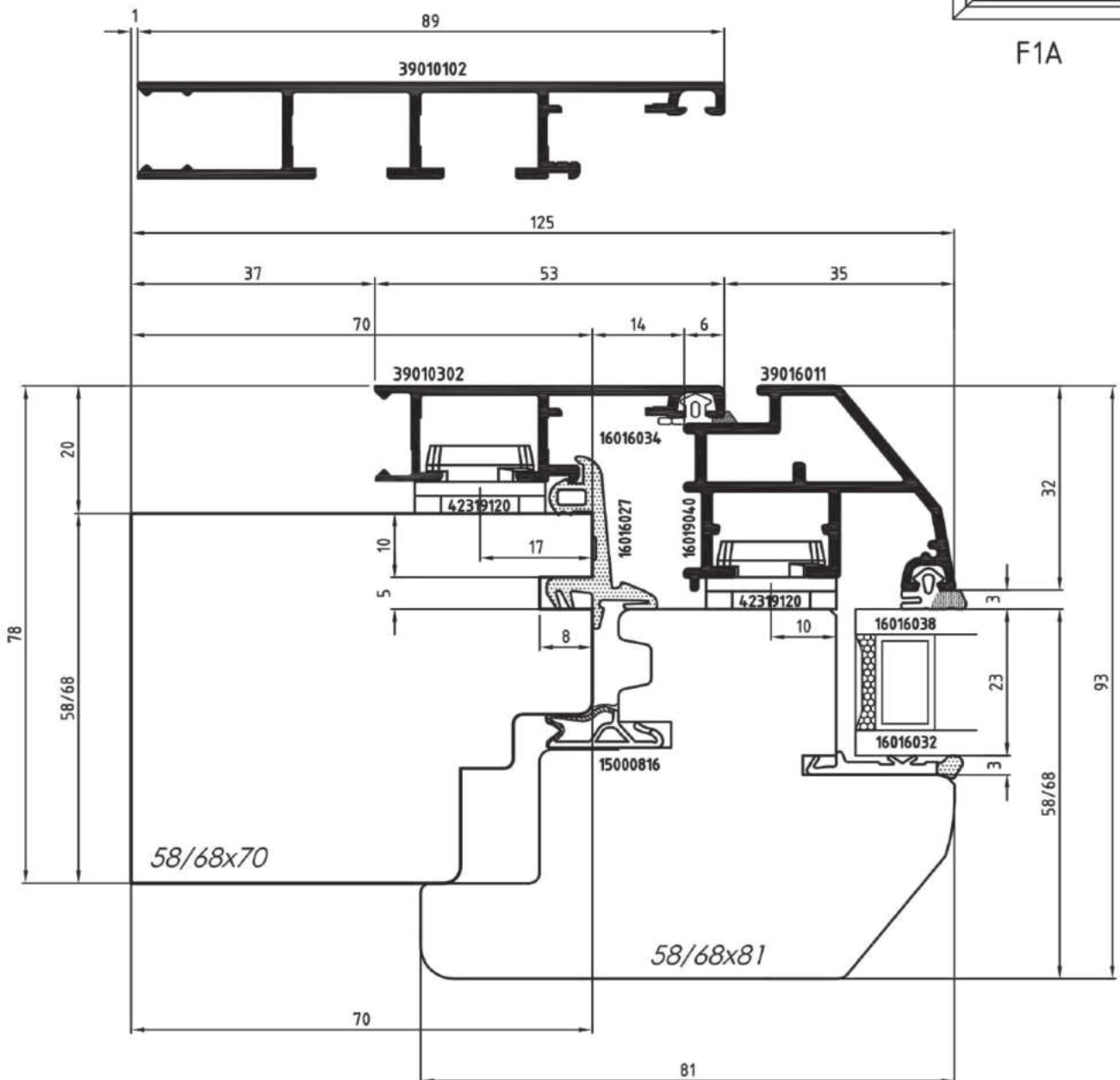

Sistema:	Scala:	Tavola:
ASTRO 6 DIAMANTE	1:1	302
Descrizione : SEZIONE VERTICALE ED ORIZZONTALE		
Nome File:		n° Pagina
ASTRO 6_Diamante rev.01		

# ASTRO 6 - sezioni

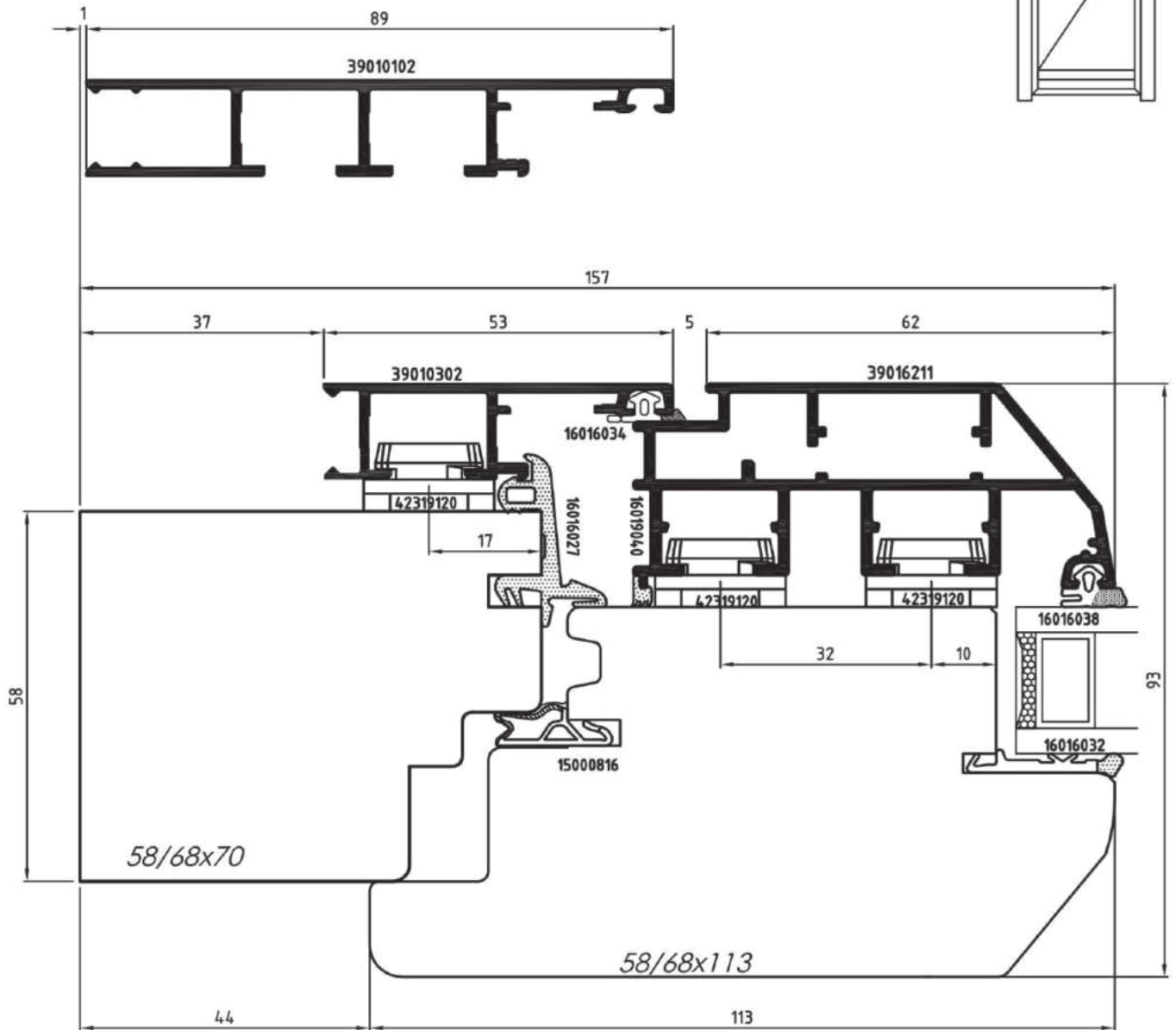
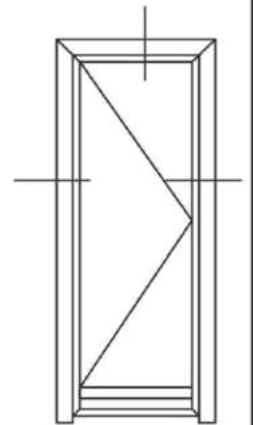

Sistema:	Scala:	Revisione e data :	Tavola:
ASTRO 6 DIAMANTE	1:1		302-V01
Descrizione :	Nome File:		
SEZIONE VERTICALE ED ORIZZONTALE	ASTRO 6_Diamante rev.01		
	n° Pagina		







# ASTRO 6 - sezioni

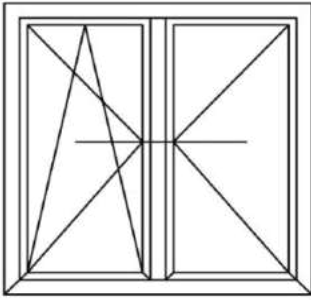

F2A

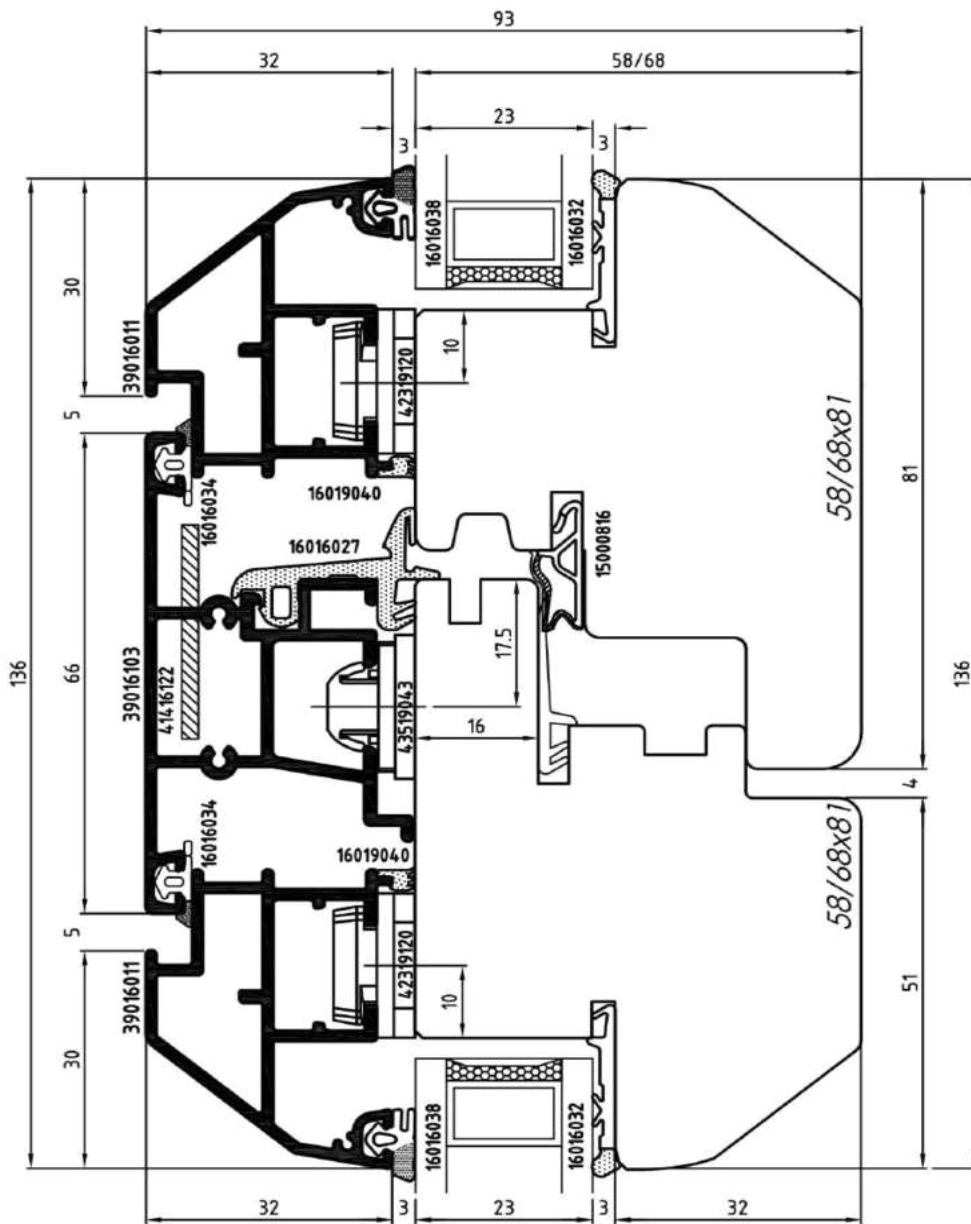
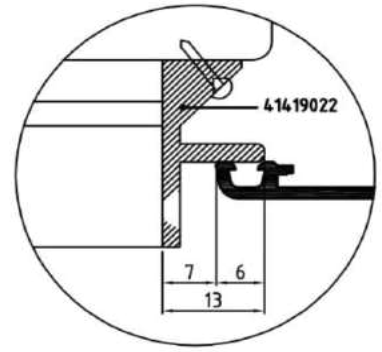

Sistema:	ASTRO 6 DIAMANTE	Scala:	1:1	Tavola:	307 V01
Descrizione:	SEZIONE ORIZZONTALE SNODO CENTRALE	Nome File:	ASTRO 6_Diamante rev.01	n° Pagina	



ASTRO 6 - sezioni

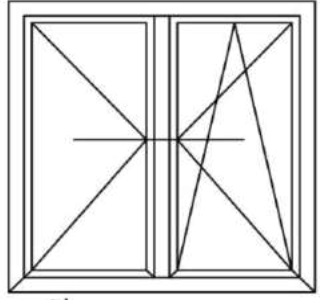

F2A

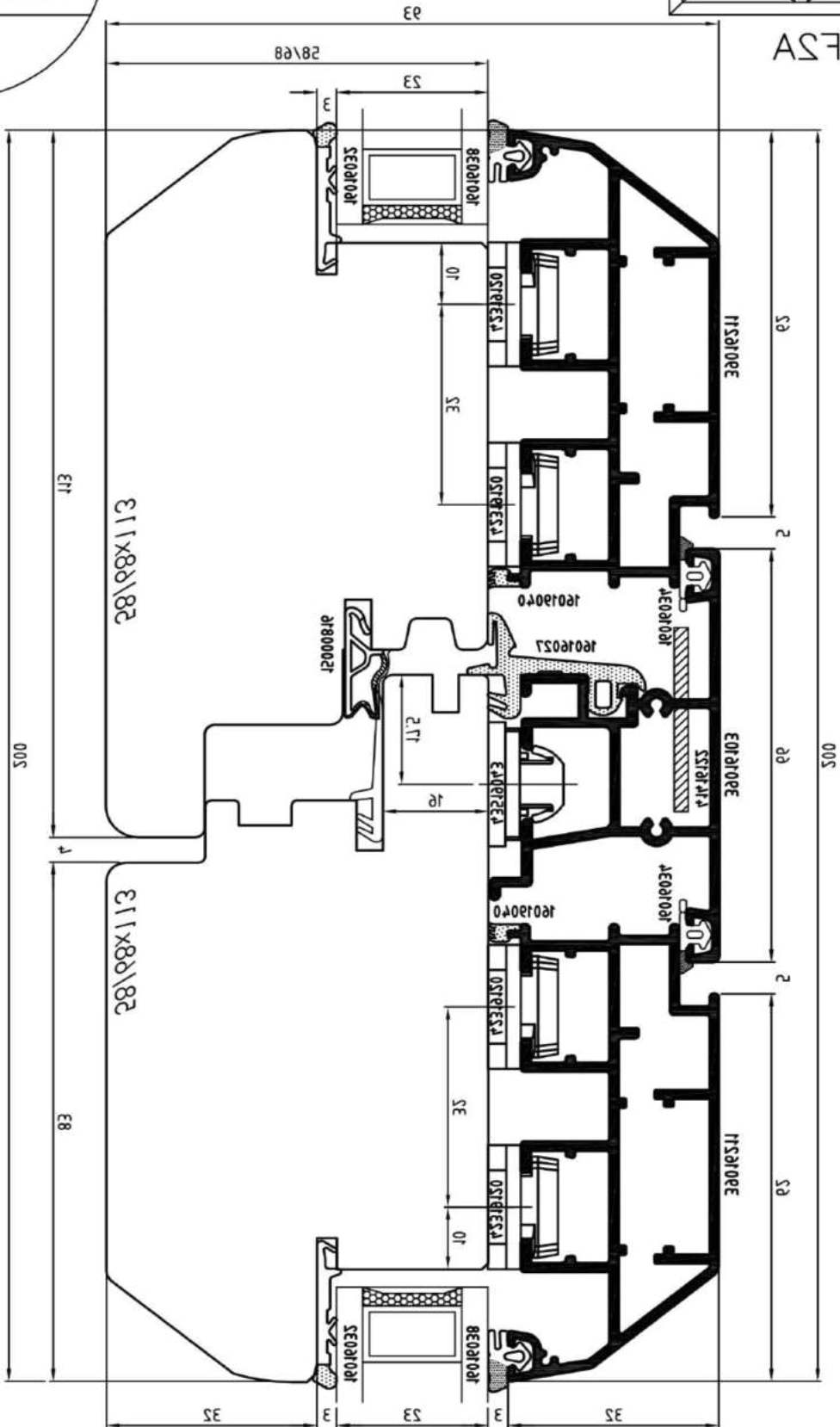
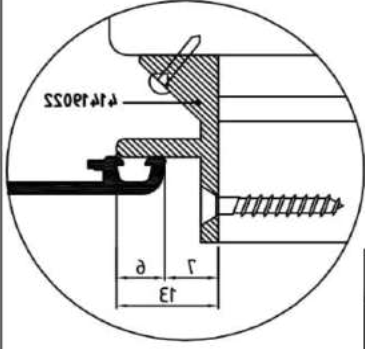

10. ver. dinamite 6x01 u. loggia n.	300-V05 al. 10001
SEZIONE ORIZZONTALE 2 MODO CENTRARE Descrizione :	1:1 scala:
ASTRO 6 DINAMITE 2000081R	28\98\113 28\98\113



ASTRO 6 - sezioni

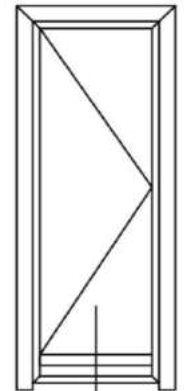
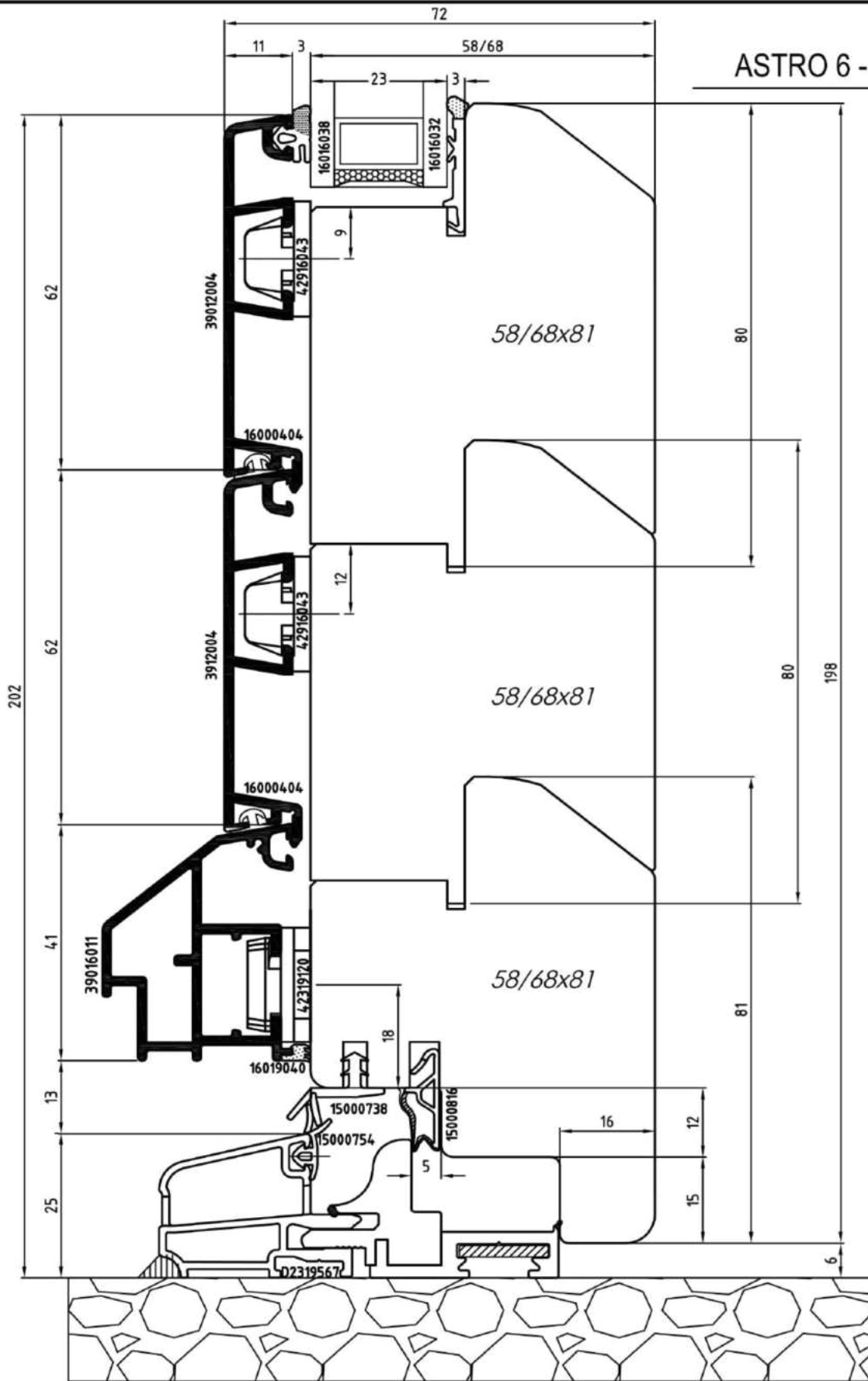

PF1A\_z2



Sistema:  
ASTRO 6 DIAMANTE

Scala:  
1:1

Tavola:  
316

Descrizione :  
SEZIONE VERTICALE TRAVERSO INFERIORE PORTAFINESTRA

Nome File:  
ASTRO 6\_Diamante Rev.01

n° Pagina



ASTRO 6 - sezioni

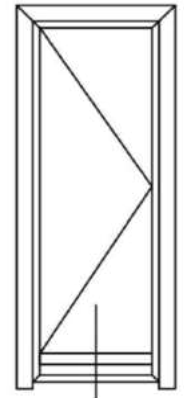
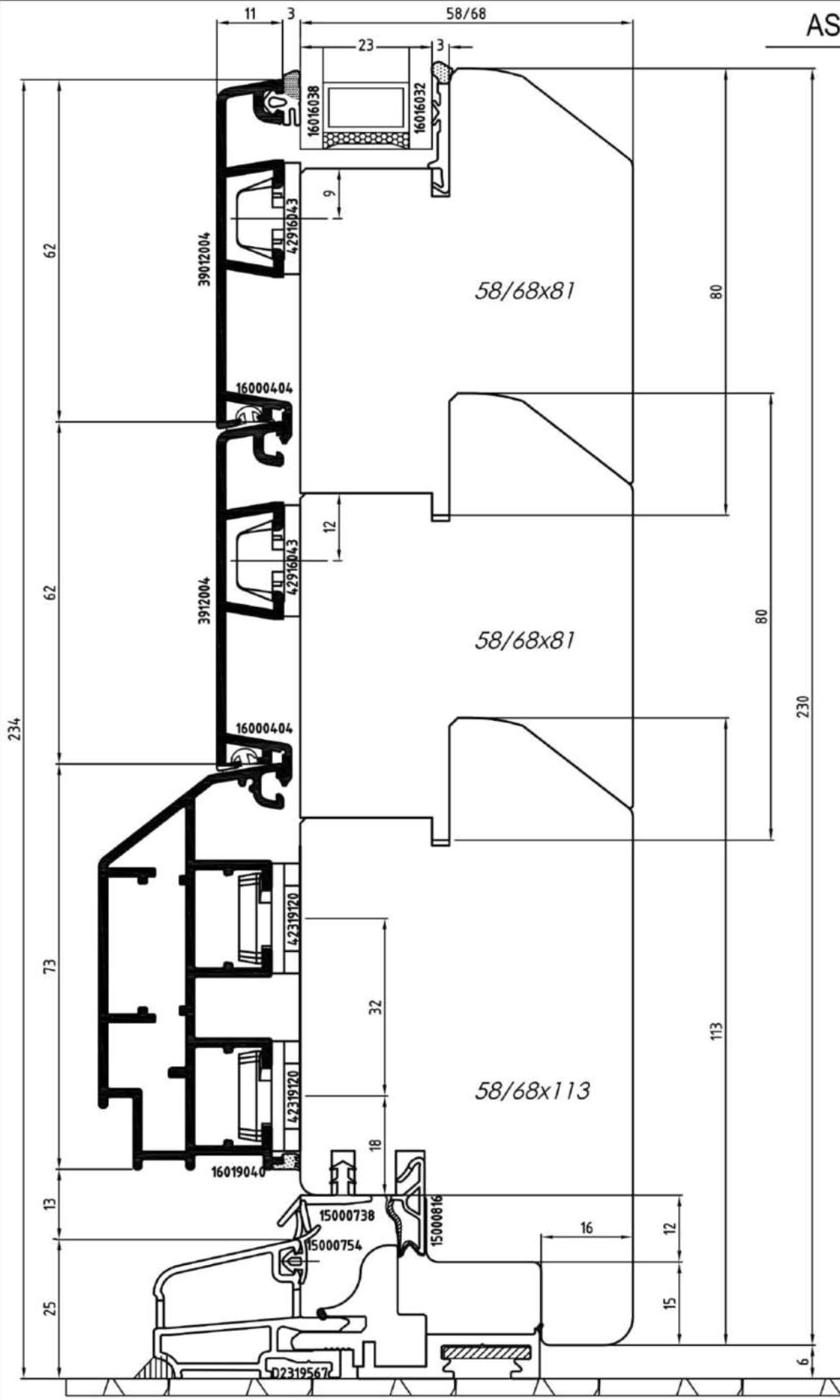

PF1A\_z2

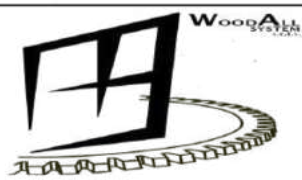

Sistema:	ASTRO 6 DIAMANTE	Scala:	1:1	Tavola:	316V01
Descrizione :	SEZIONE VERTICALE TRAVERSO INFERIORE PORTAFINESTRA				
	Nome File:	ASTRO 6_Diamante Rev.01			
		n° Pagina			



# ASTRO 6 - sezioni

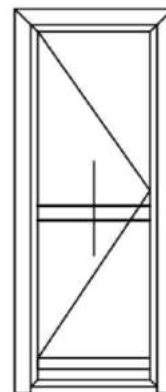
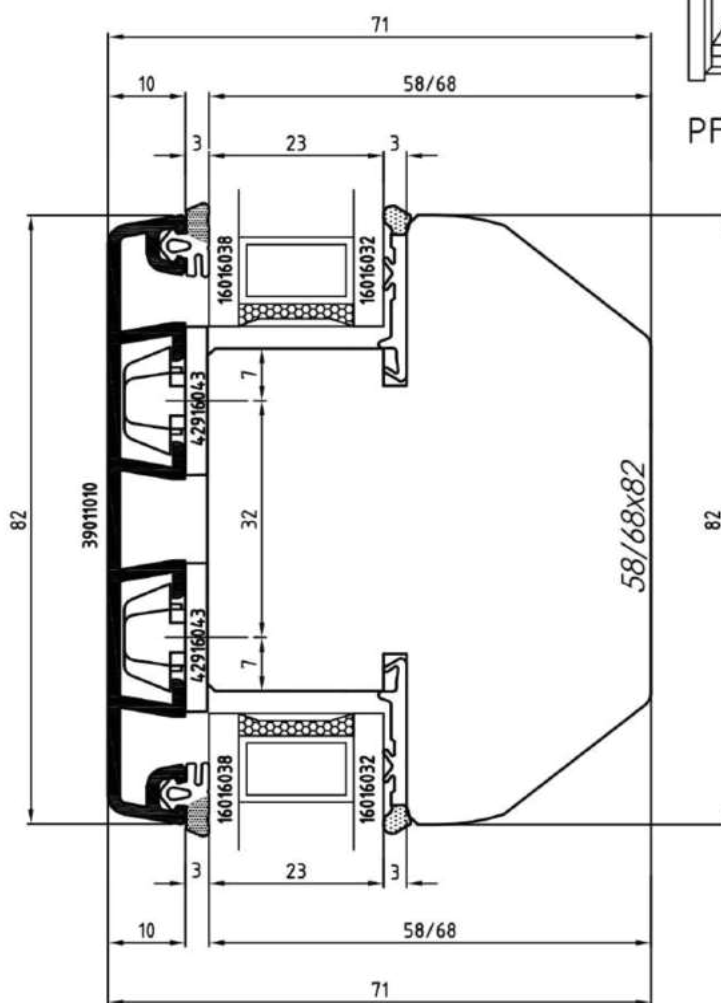
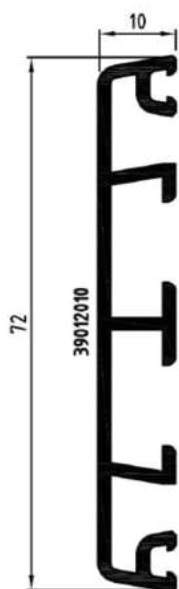

PF1A\_z2

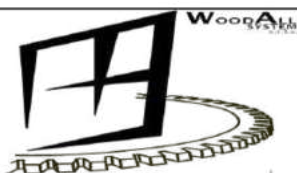

Sistema:	Scala:	Tavola:
ASTRO 6 DIAMANTE	1:1	326
Descrizione : SEZIONE VERTICALE TRAVERSO SU ANTA		
Nome File:		n° Pagina
ASTRO 6_Diamante Rev.01		

Profilo Montantino

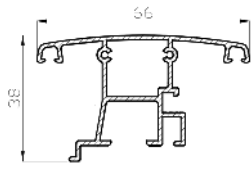

39016003

Profilo zoccolo

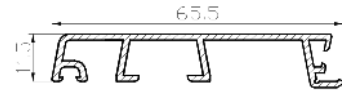

39012004

Profilo Anta Diamante

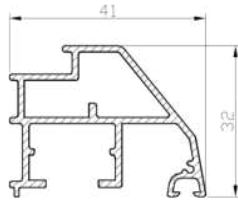

39016011

Profilo Anta Diamante

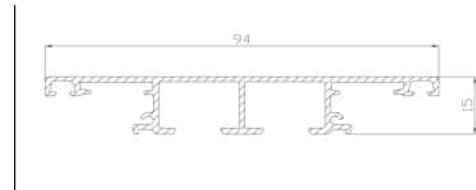

39016113

Profilo Anta Diamante

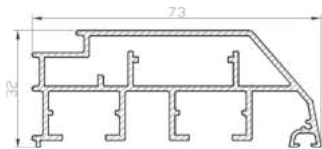

39016211

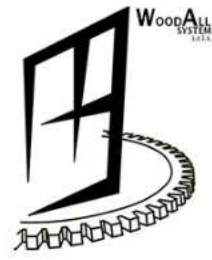

ASTRO 6

SYSTEM

W  
O  
O  
D

QUADRA

**ALL**

OLTRE  
CIO' CHE VEDI!

ASTRO 6 - sezioni

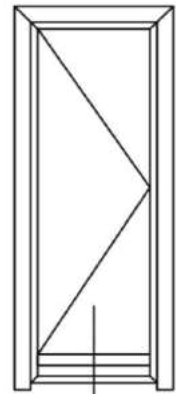
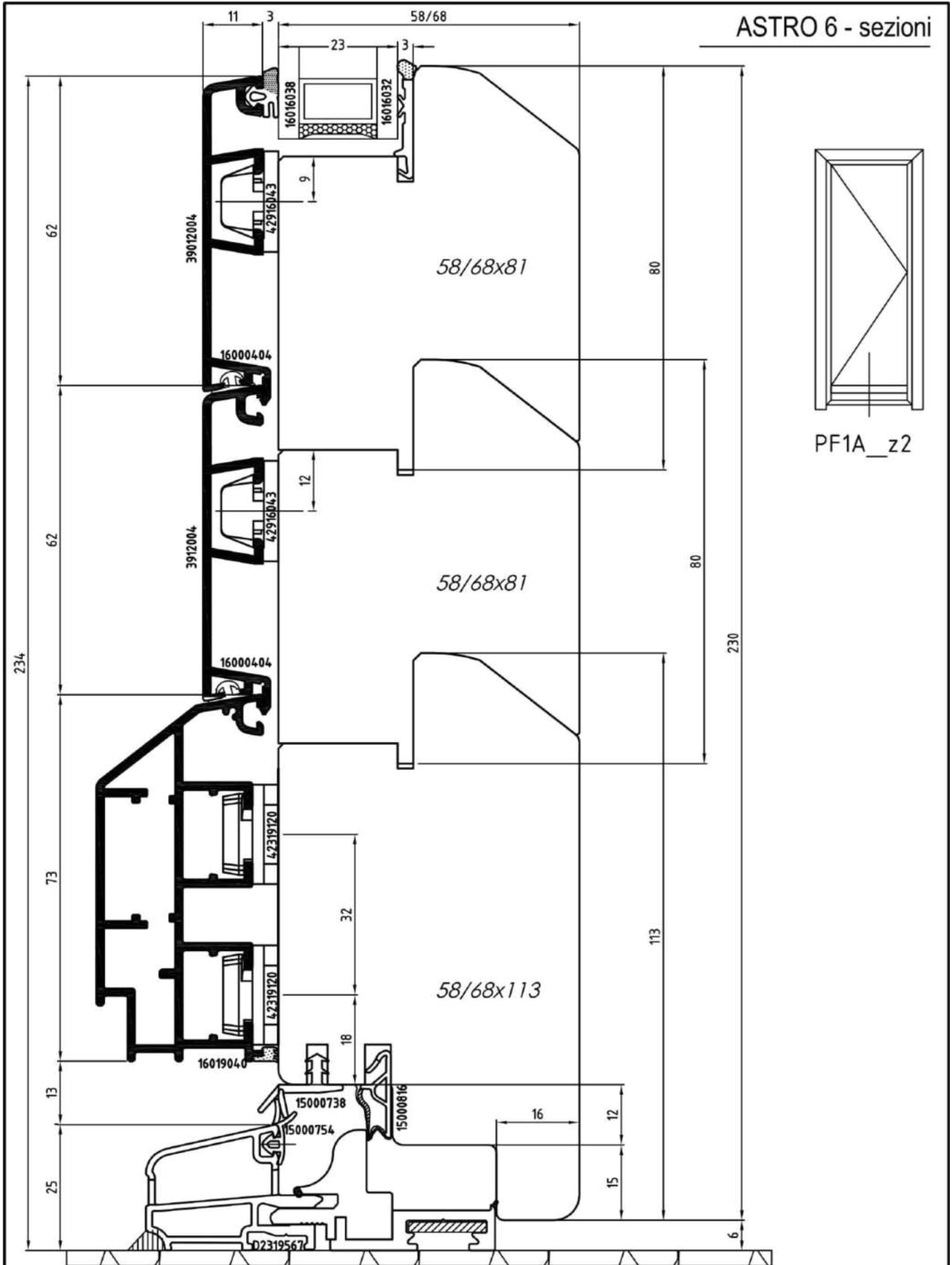

PF1A\_z2



Sistema:	ASTRO 6 DIAMANTE	Scala:	1:1	Tavola:	316V01
Descrizione :	SEZIONE VERTICALE TRAVERSO INFERIORE PORTAFINESTRA				
Nome File:	ASTRO 6_Diamante Rev.01				n° Pagina

# ASTRO 6 QUADRA - sezioni

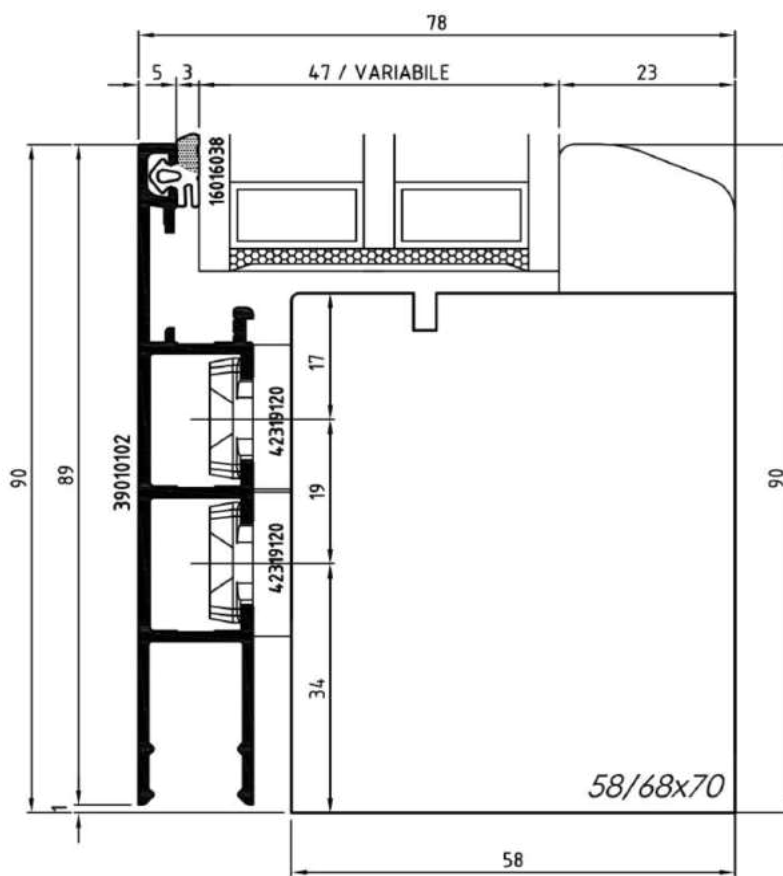
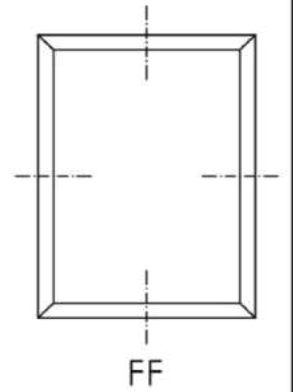

Sistema: <b>ASTRO 6 QUADRA</b>	Scala: 1:1	Revisione e data : Rev.00	Tavola: 301
Descrizione : <b>SEZIONE VERTICALE VETRO FISSO</b>			
Nome File: ASTRO 6_Quadra rev.00			n° Pagina

# ASTRO 6 QUADRA - sezioni

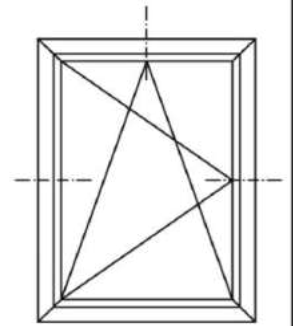

F1A

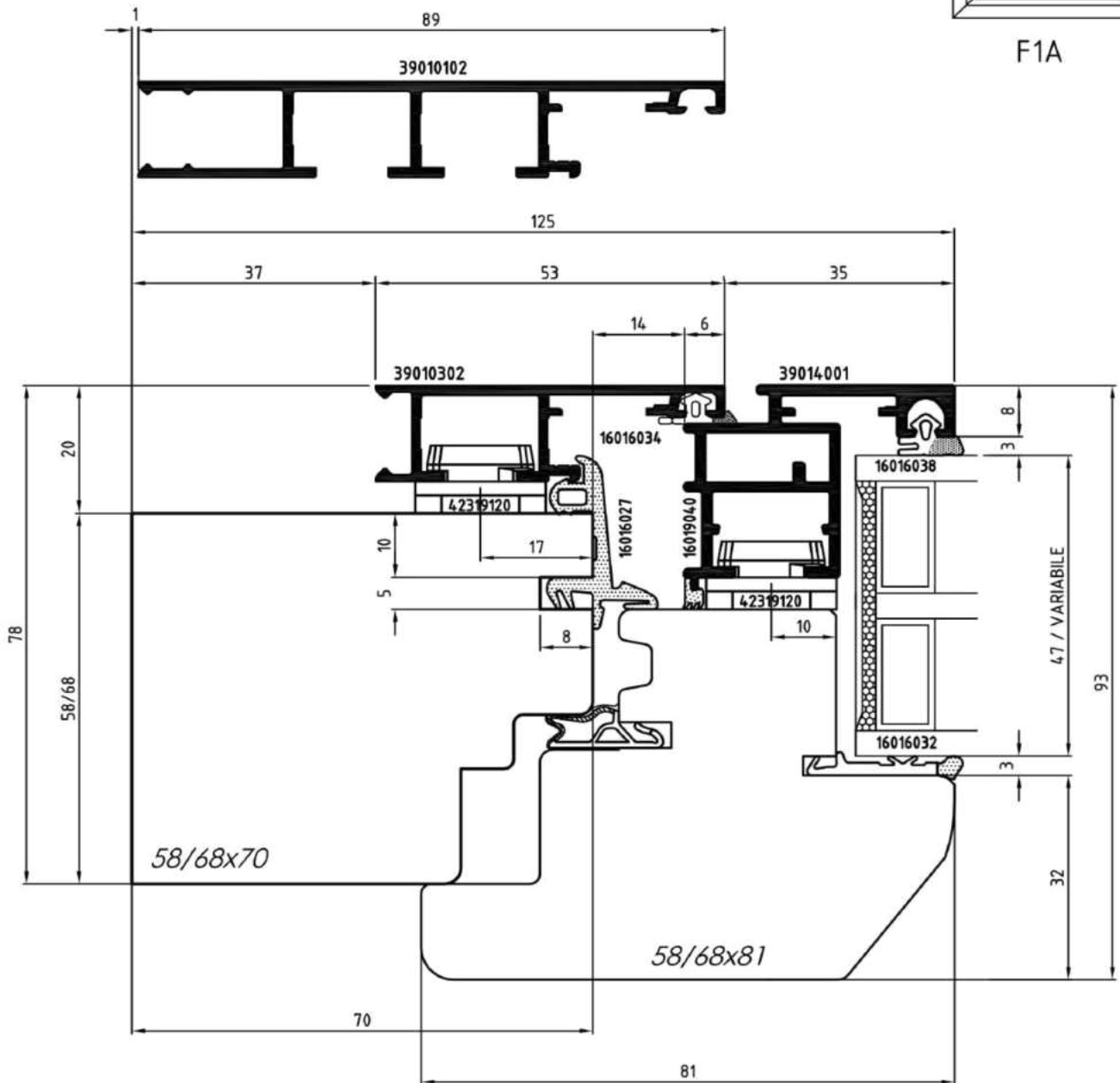

Sistema: <b>ASTRO 6 QUADRA</b>	Scala: 1:1	Revisione e data : Rev.00	Tavola: 302
Descrizione : SEZIONE VERTICALE ED ORIZZONTALE			
Nome File: ASTRO 6_Quadra rev.00			n° Pagina



# ASTRO 6 QUADRA - sezioni

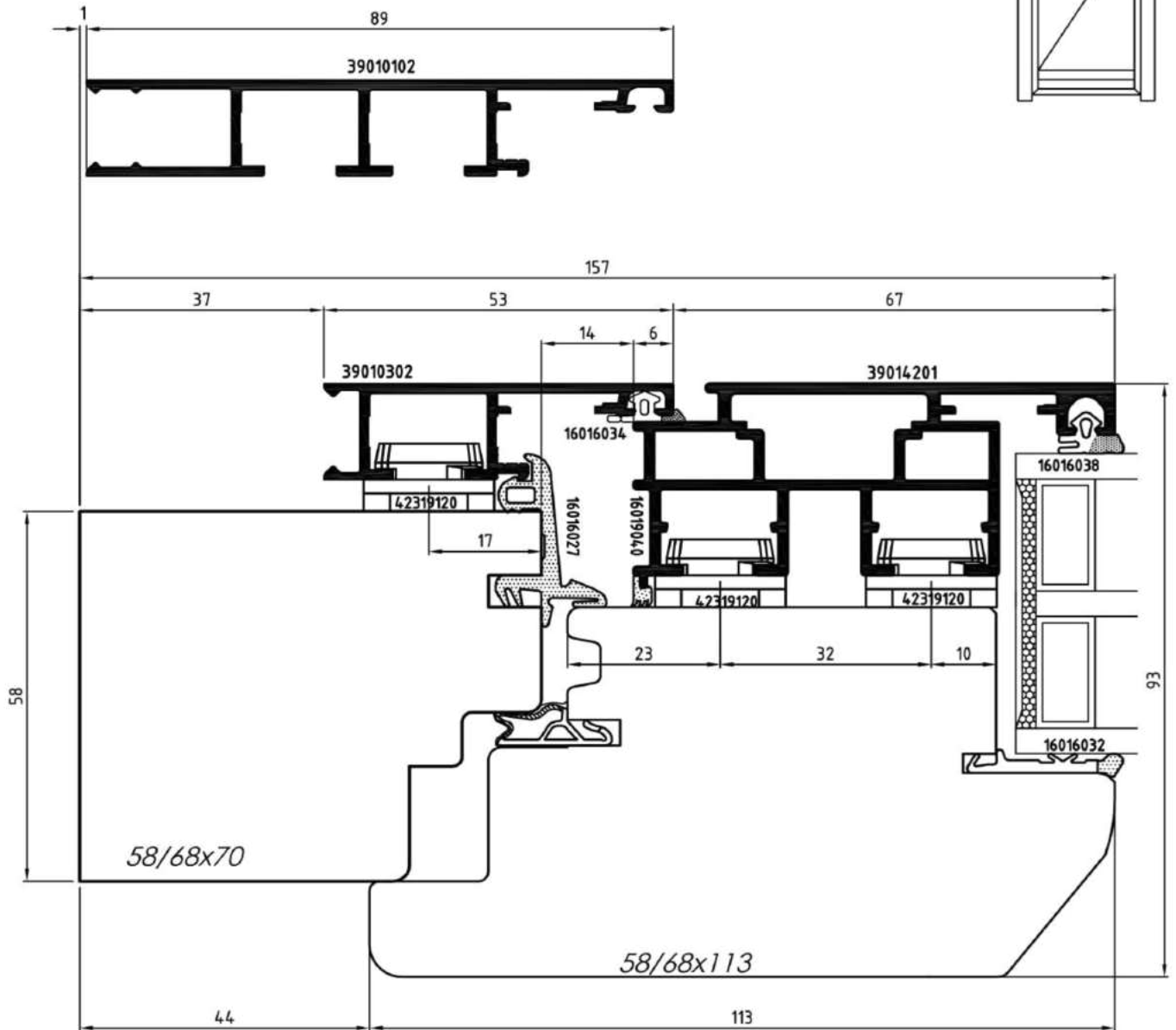
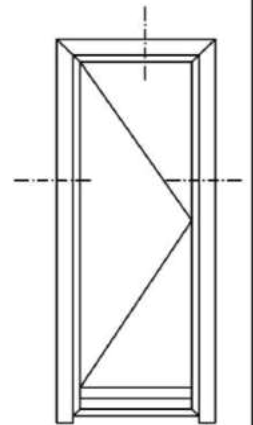

Sistema: <b>ASTRO 6 QUADRA</b>	Scala: 1:1	Revisione e data : Rev.00	Tavola: 317
Descrizione : SEZIONE VERTICALE ED ORIZZONTALE			
Nome File: ASTRO_6_Quadra rev.00			n° Pagina

# ASTRO 6 QUADRA - sezioni

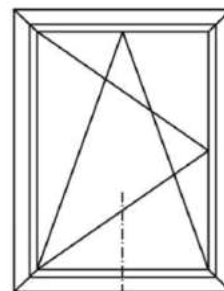

F1A

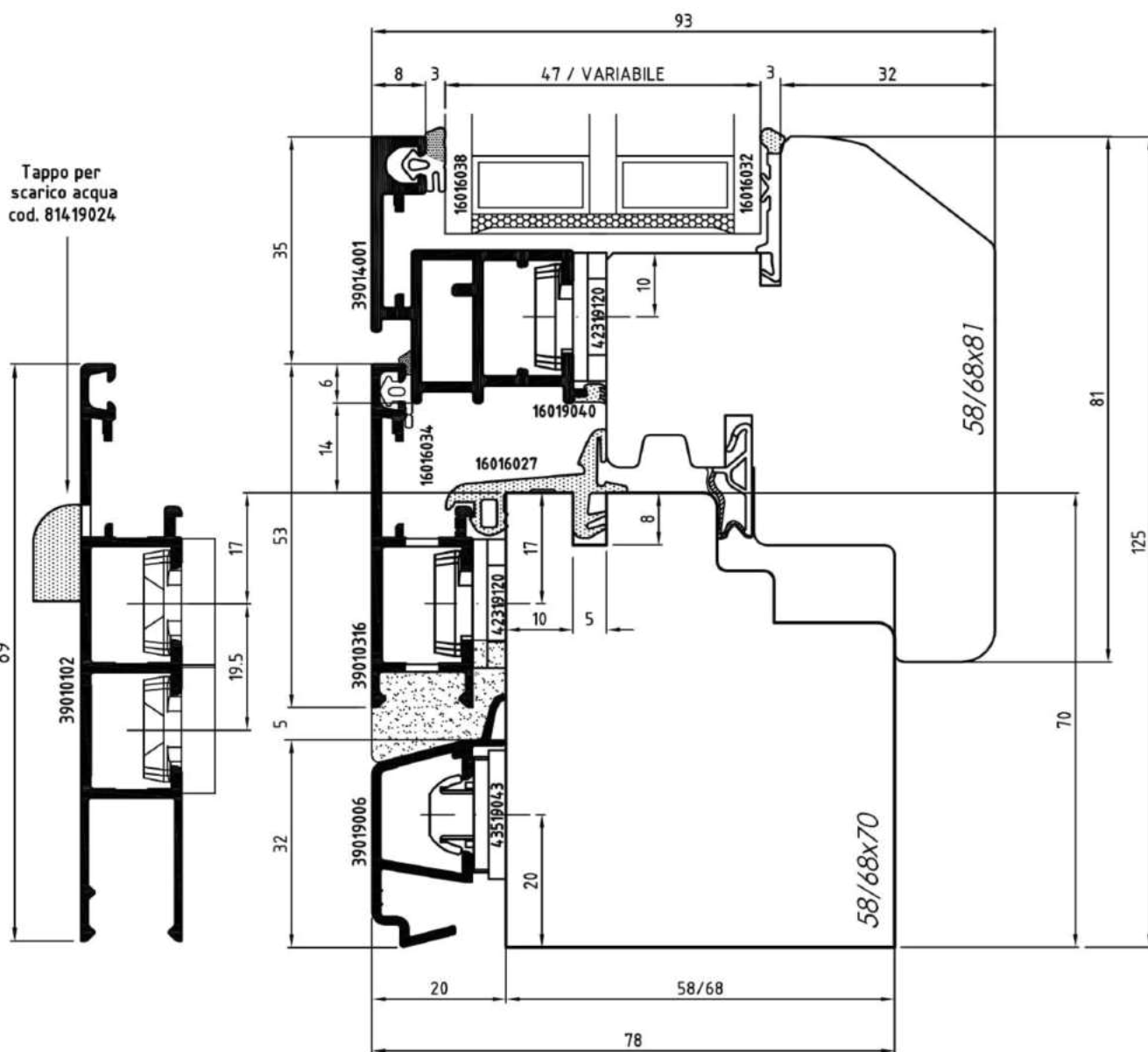

Sistema: <b>ASTRO 6 QUADRA</b>	Scala: 1:1	Revisione e data : Rev.00	Tavola: 303
Descrizione : SEZIONE VERTICALE TRAVERSO INFERIORE FINESTRA			
Nome File: ASTRO_6_Quadra rev.00			n° Pagina







# ASTRO 6 QUADRA - sezioni

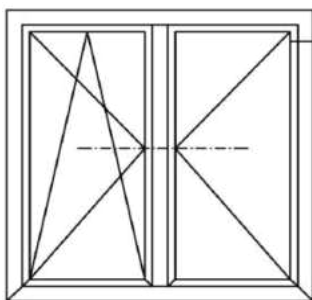

F2A

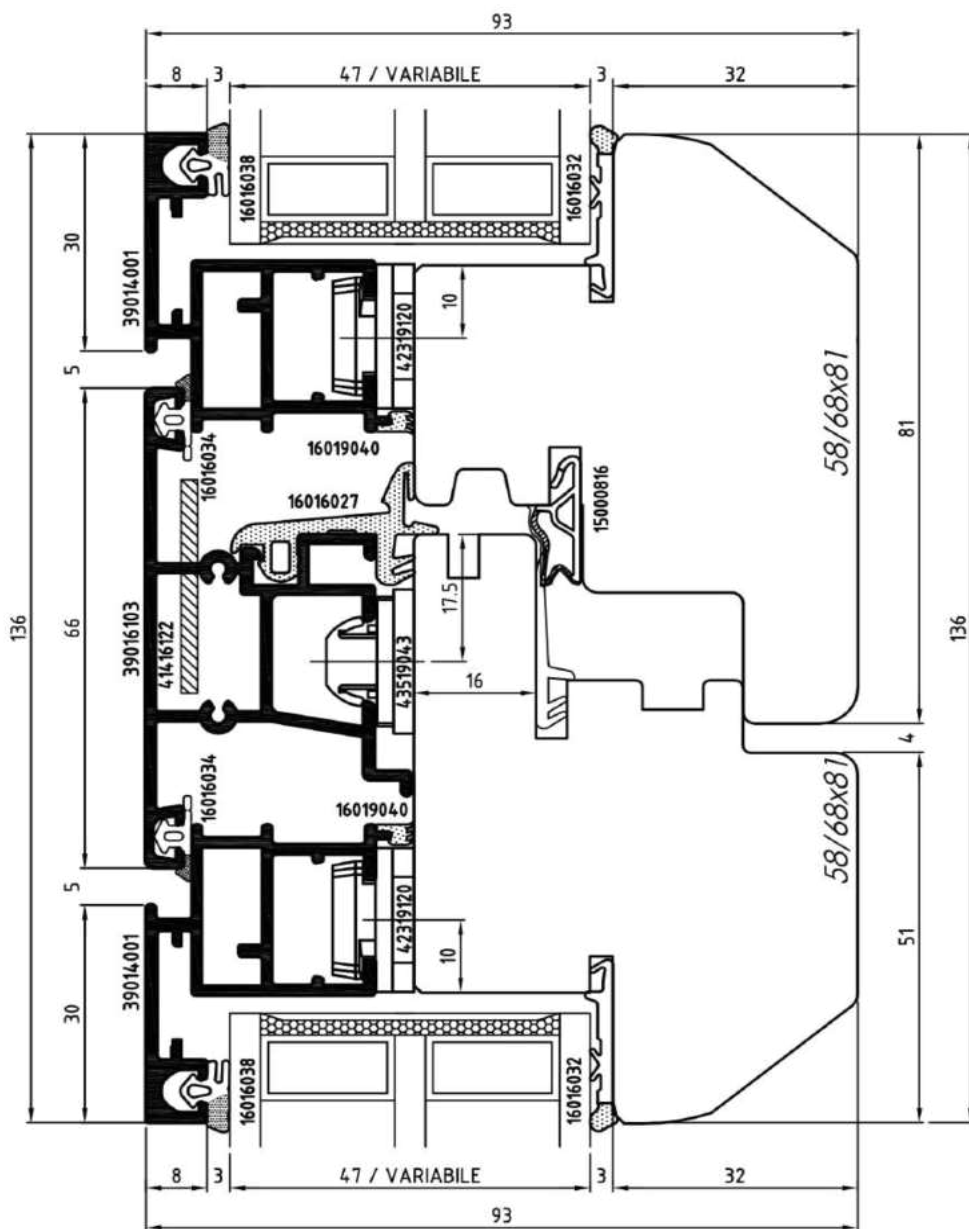
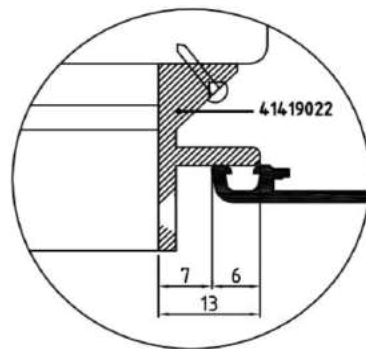

Sistema:	ASTRO 6 QUADRA	Scala:	1:1	Revisione e data:	Rev.00	Tavola:	307v1
Descrizione:	SEZIONE ORIZZONTALE SNODO CENTRALE						
Nome File:	ASTRO 6_Quadra rev.00						
							n° Pagina





# ASTRO 6 QUADRA - sezioni

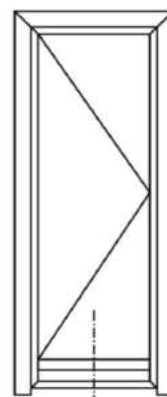
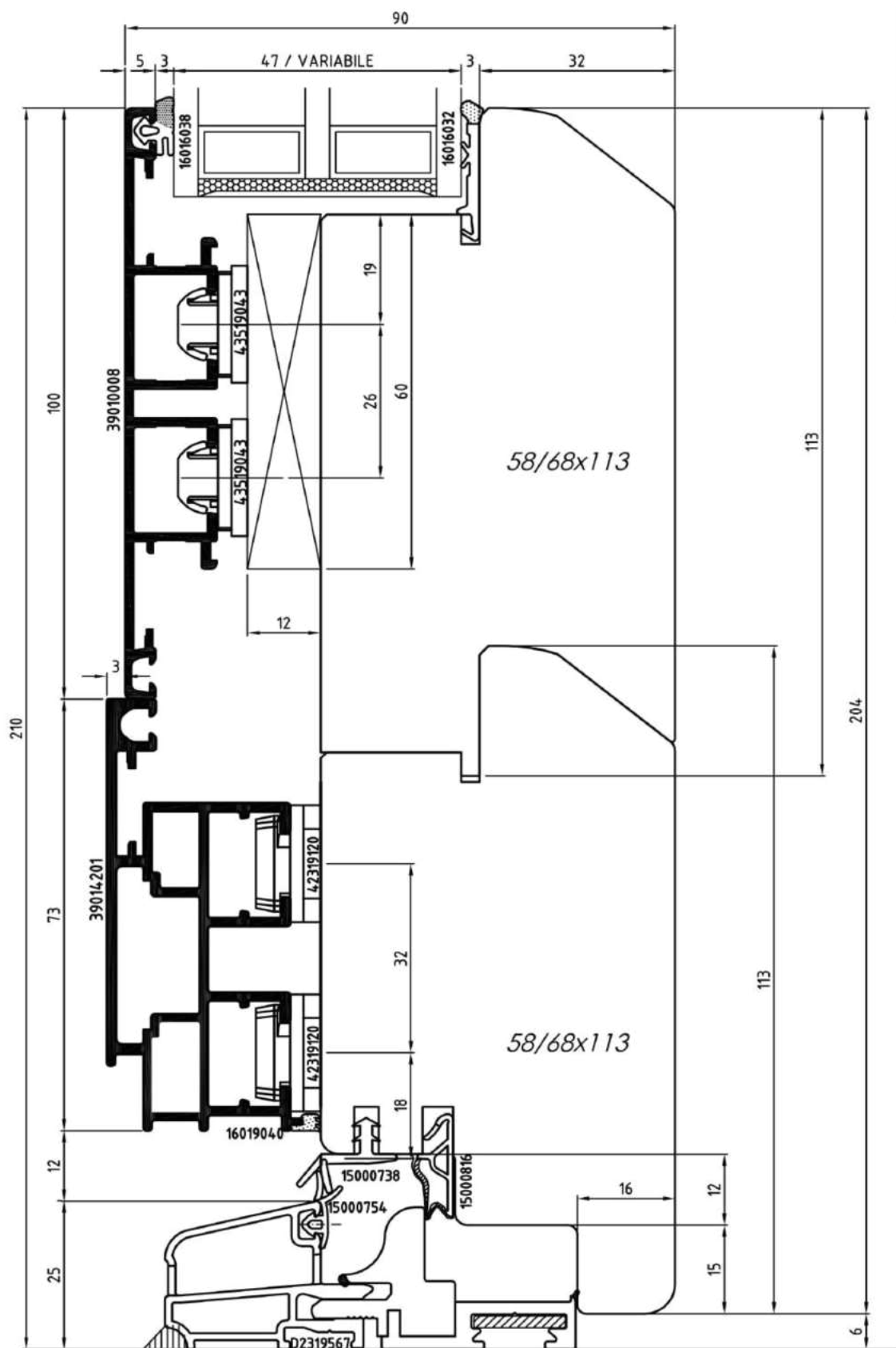

PF1A\_z2



Sistema:  
**ASTRO 6 QUADRA**

Scala:  
**1:1**

Revisione e data :  
**Rev.00**

Tavola:  
**316v1**

Descrizione :  
**SEZIONE VERTICALE TRAVERSO INFERIORE PORTAFINESTRA**

Nome File:

n° Pagina

**ASTRO\_6\_Quadra rev.00**

ATTENZIONE:  
 FISSARE TRAMITE CLIPS  
 COD.42319043 IL PROF. COD.  
 39019003  
 DOPO AVER FISSATO IL PROF.  
 ANTA LARGA COD. 39019201

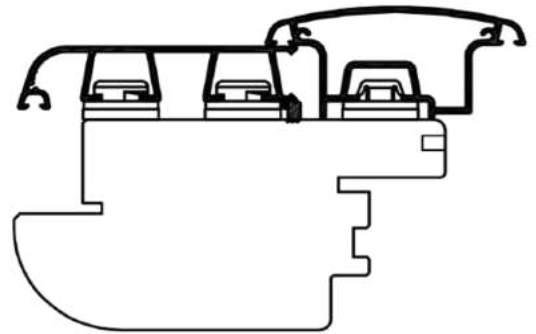
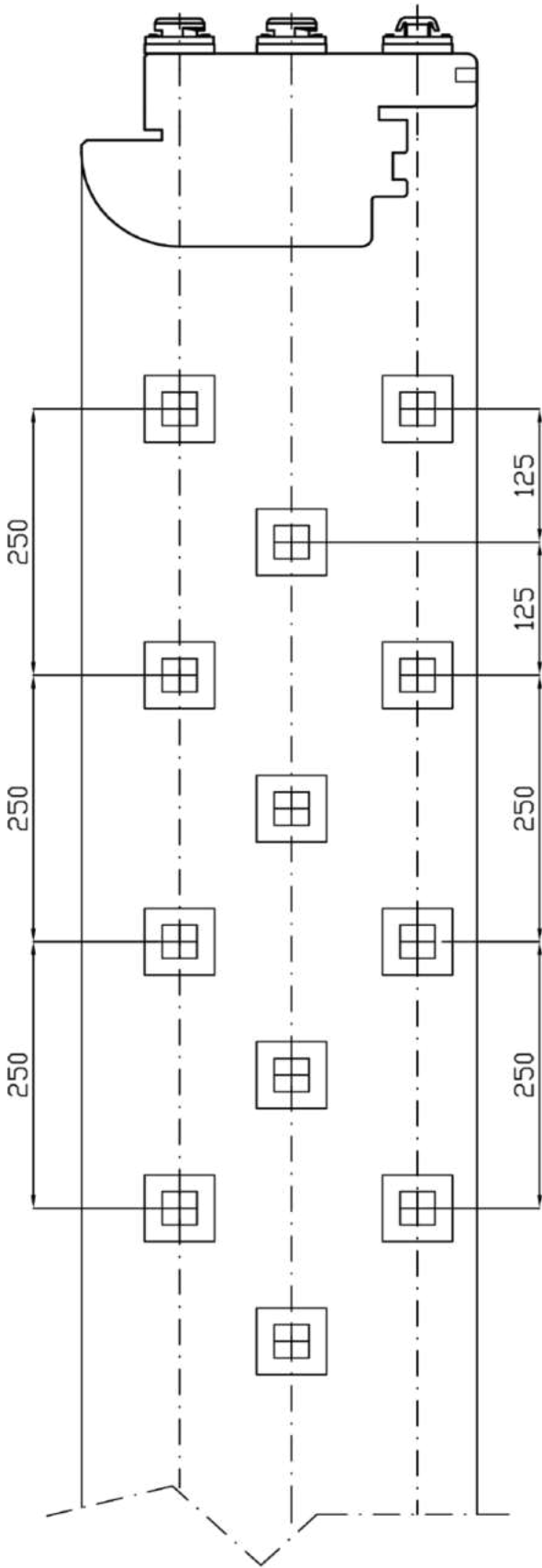

\* è consigliato l'uso di viti autofilettanti da 3,5X25 a testa svasata per il fissaggio della clips sul legno

			Sistema Astro 9	09S
	Cliente Standard		REV. 05	Scala Disegno
Descrizione: <b>DISPOSIZIONE MONTAGGIO CLIPS SU MONTANTE</b>			Tolleranze Generali	± 0,5 mm
Mod_35_REV01			PAGINA	

Chiave a 90° per gli agganci

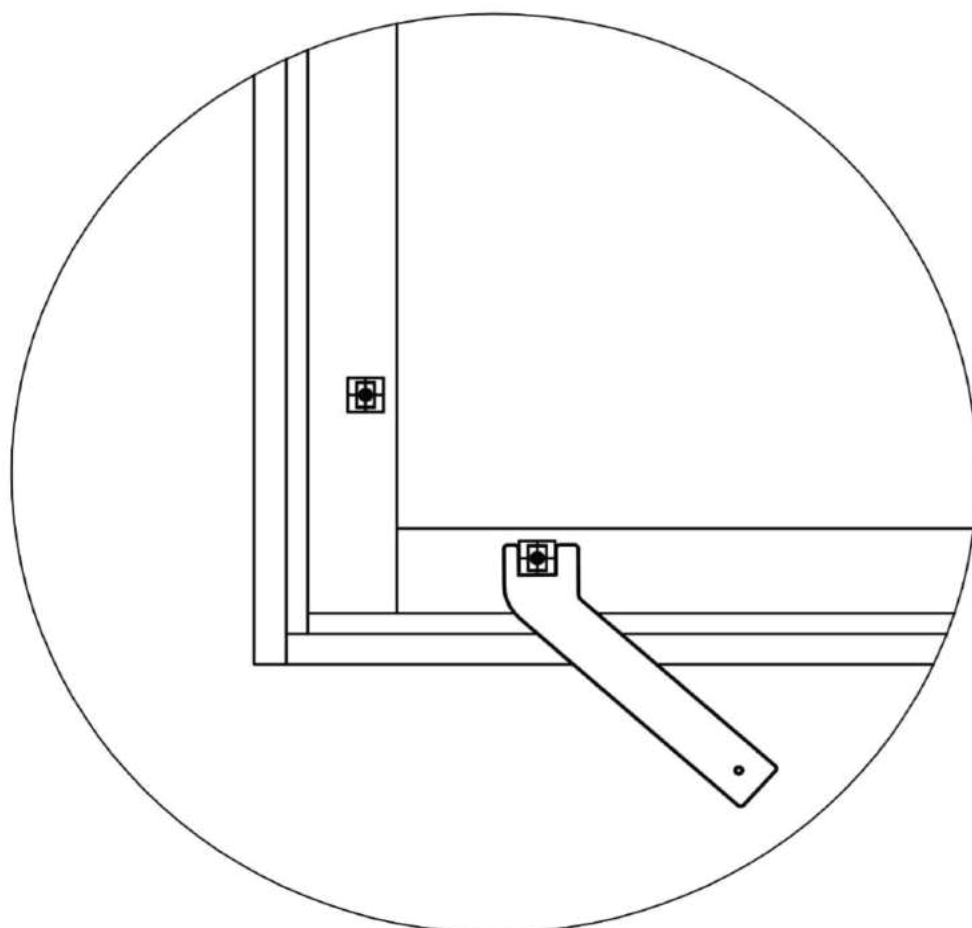
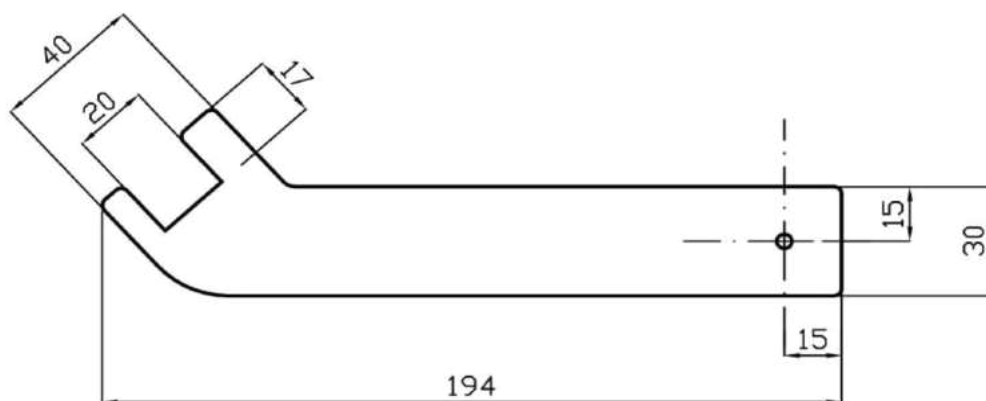

				Sistema Astro 9	06S
	Cliente Standard		REV. 05	Scala Disegno	Fuori Scala
Descrizione: <b>CHIAVE FISSAGGIO CLIP</b>			Tolleranze Generali --- PAGINA		
Mod_35_REV01					

# ESEMPIO DI UTILIZZO DIME

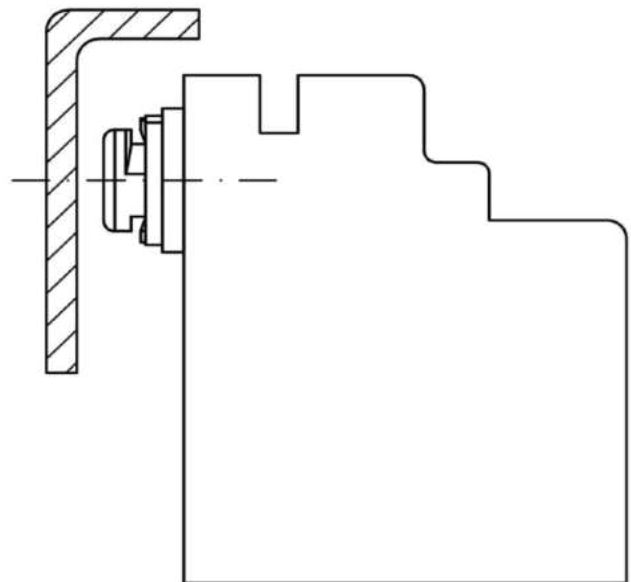
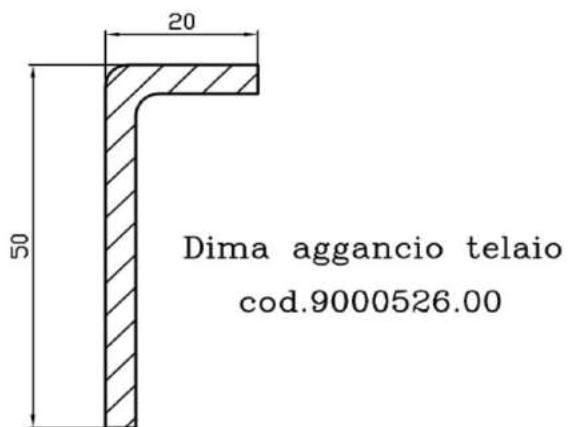
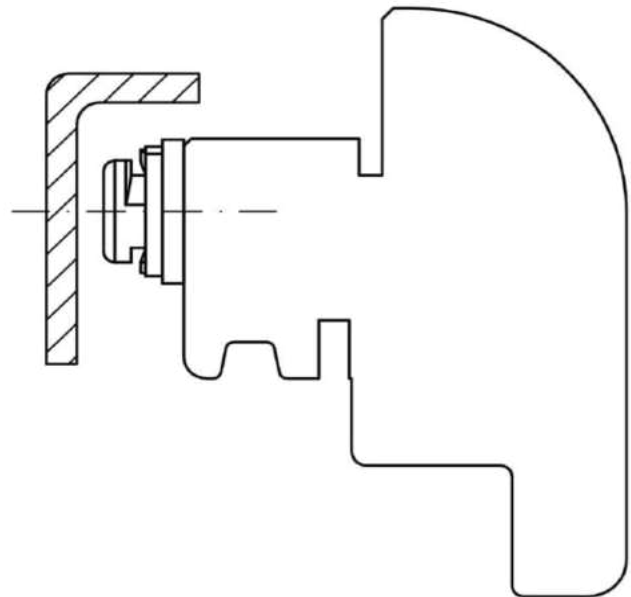
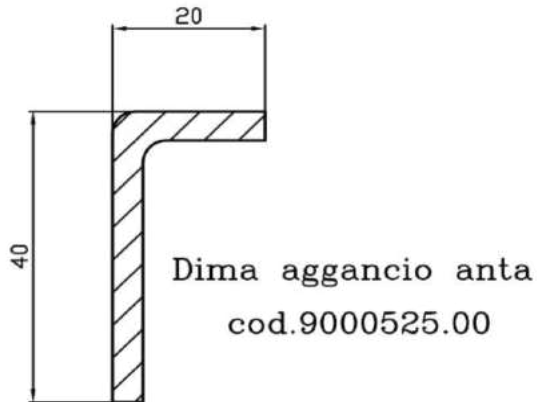

				Sistema <b>ASTRO 9</b> 06S
	Cliente Standard		REV. 05	Scala Disegno 1:1
Descrizione: <b>ESEMPIO DI UTILIZZO DIME</b>				Tolleranze Generali $\pm 0,5\text{mm}$
Mod_35_REV01				PAGINA

Profilo Zoccolo

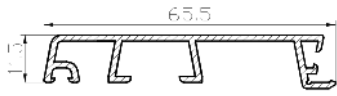

39012004

Profilo Anta Larga Diamante

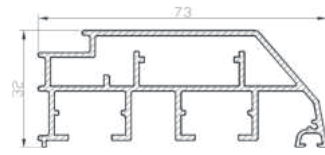

39016211

Profilo Montantino

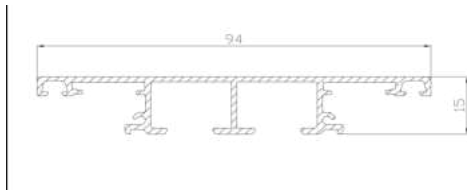

39016113

Profilo Anta Triplo vetro

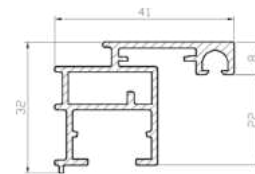

39014001

Profilo Montantino

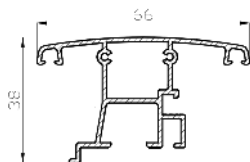

39016005

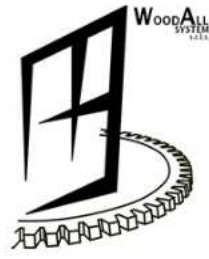

OLTRE  
CIO' CHE VEDI!



Misura interno telaio

TELAIO

Misura esterno telaio

Misura interno anta

ANTA

Misura esterno anta

				Sistema <b>ASTRO 9</b>	09S
	Ciente Standard			REV. 05	Scala Disegno
Descrizione: <b>SCHEMA SEMPLIFICATIVO DI COME PRENDERE LE MISURE</b>				Tolleranze Generali	$\pm 0,5$ mm
Mod_35_REV01				PAGINA	

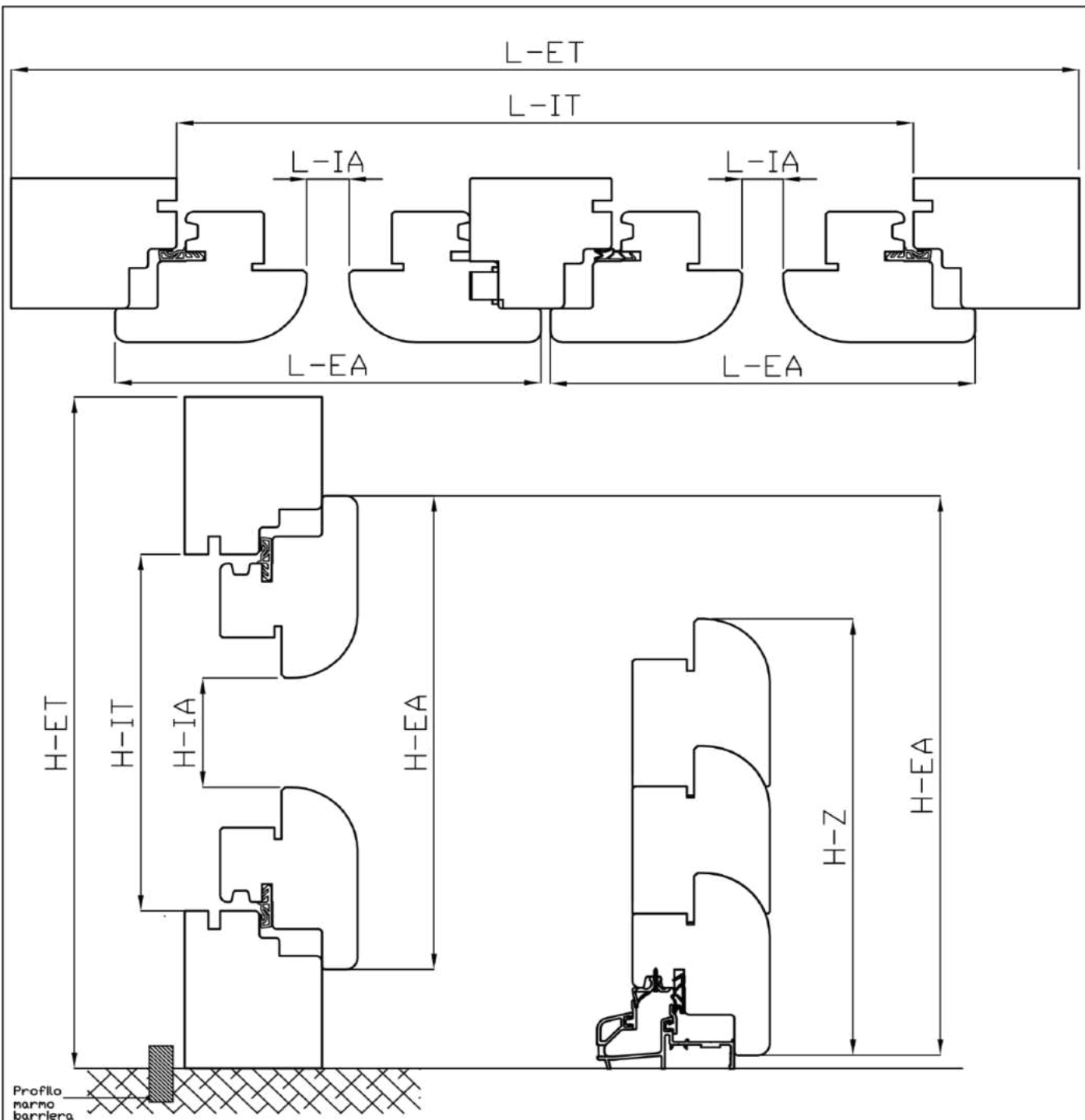

### SCHEMA RILEVAMENTO MISURE

- L-ET LARGHEZZA ESTERNA TELAIO
- L-EA LARGHEZZA ESTERNA ANTA
- L-IT LARGHEZZA INTERNA TELAIO
- L-IA LARGHEZZA INTERNA ANTA
- H-ET ALTEZZA ESTERNA TELAIO
- H-IT ALTEZZA INTERNA TELAIO
- H-IA ALTEZZA INTERNA ANTA
- H-EA ALTEZZA ESTERNO ANTA
- H-Z ALTEZZA ANTA + ZOCCOLI

NEL CASO DI PORTAFINESTRE EVIDENZIARE SE SI TRATTA DI TRAVERSO INFERIORE CON SOGLIA O PARAFREDDO

			Sistema <b>ASTRO 9</b>	09S
	Cliente Standard		REV. 05	Scala Disegno
Descrizione: <b>SCHEMA SEMPLIFICATIVO DI COME PRENDERE LE MISURE</b>			Tolleranze Generali	---
			PAGINA	

## ELENCO TIPOLOGIE SPECIALI

Finestra Fuori Squadro "A"

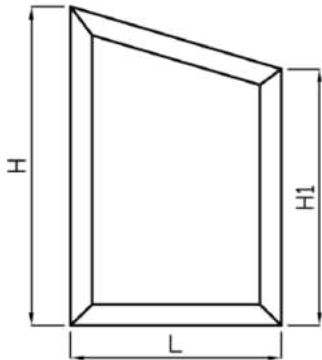

Finestra Fuori Squadro Triangolare "B"

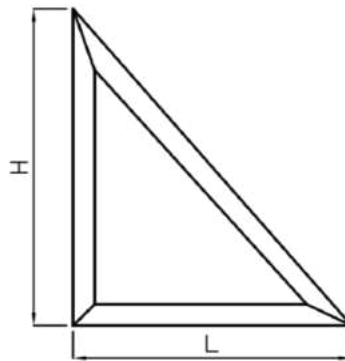

Finestra ad arco tutto sesto "C"

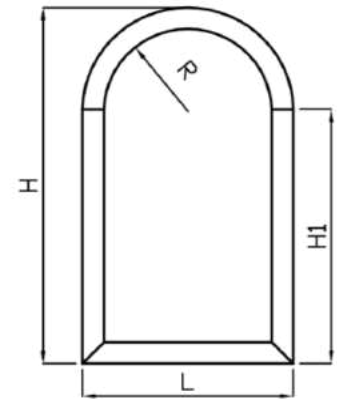

Finestra ad arco sesto ribassato "D"

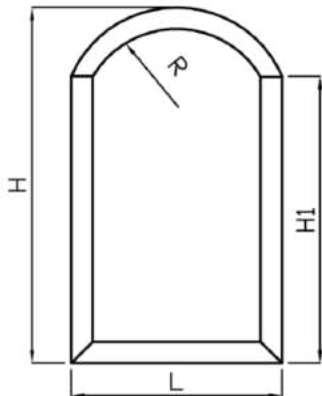

Finestra ad arco a tre raggi "E"

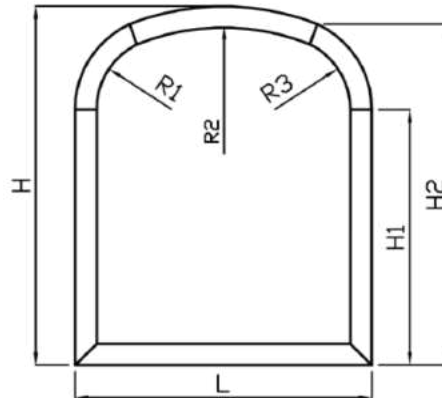

Finestra ad oblò "F"

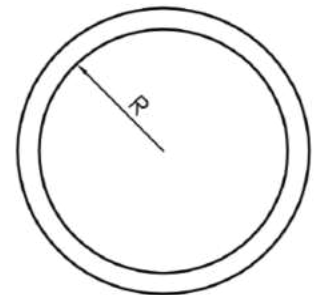

### NOTE:

- Per la perfetta realizzazione delle tipologie ad arco, è consigliabile non scendere sotto i raggi minimi di piegatura "VEDERE ELENCO RAGGI MINIMI".
- Si veda pagina 009 per lo schema di rilevamento quote.
- La vista delle tipologie è sempre intesa interna con apertura a tirare.
- L'angolo minimo di taglio garantito delle tipologie fuori squadra è di 22,5°. Tipologia tipo "B".

### TIPOLOGIE AD ARCO:

RAGGIO ESTERNO TELAIO LEGNO MINIMO REALIZZABILE:

ASTRO 6 -----> 500 mm.  
 ASTRO 9 -----> 500 mm.  
 ASTRO 5 -----> 800 mm.

		REV. 00	<b>TIPOLOGIE SPECIALI: ARCHI &amp; FUORI SQUADRO</b>
Descrizione: <h2 style="text-align: center;">TIPOLOGIE DI SERRAMENTI SPECIALI</h2>			PAGINA
Mod_35_REV01			

# SCHEMA RILEVAMENTO QUOTE

**SISTEMA ASTRO 6**

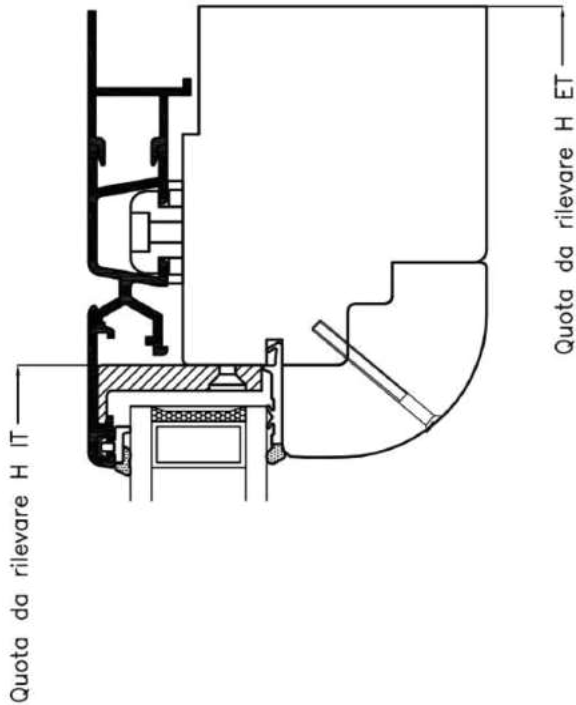

**SISTEMA ASTRO 9**

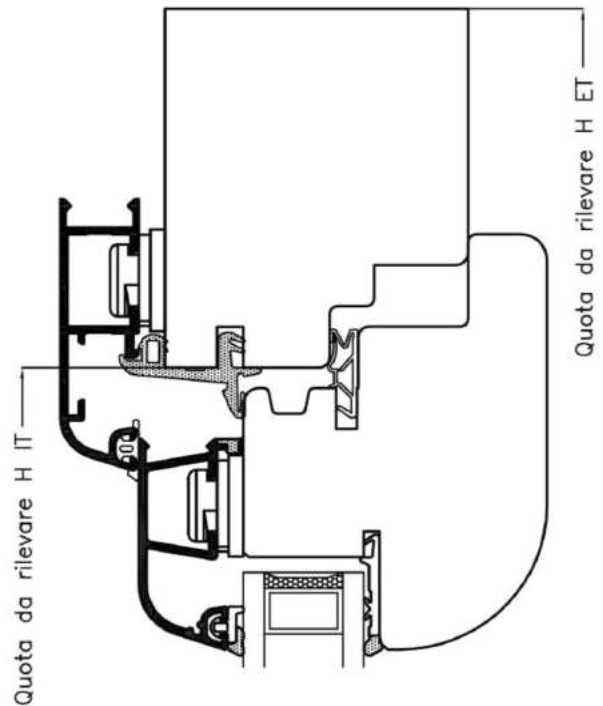
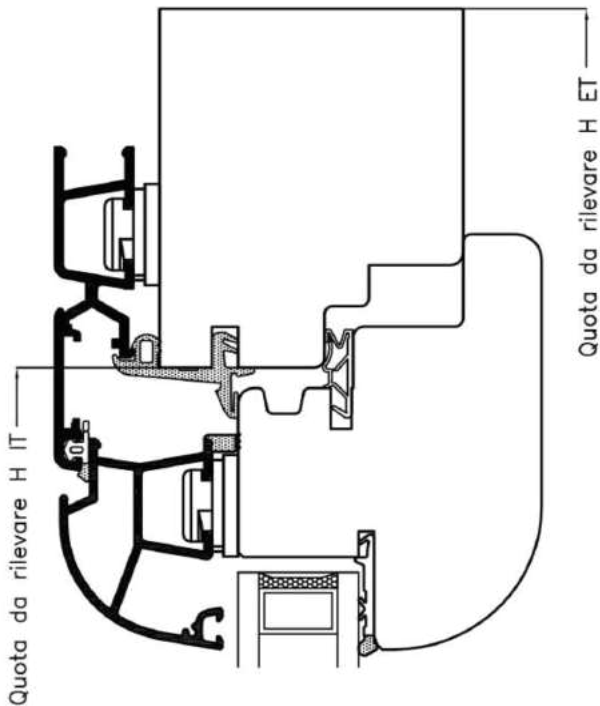
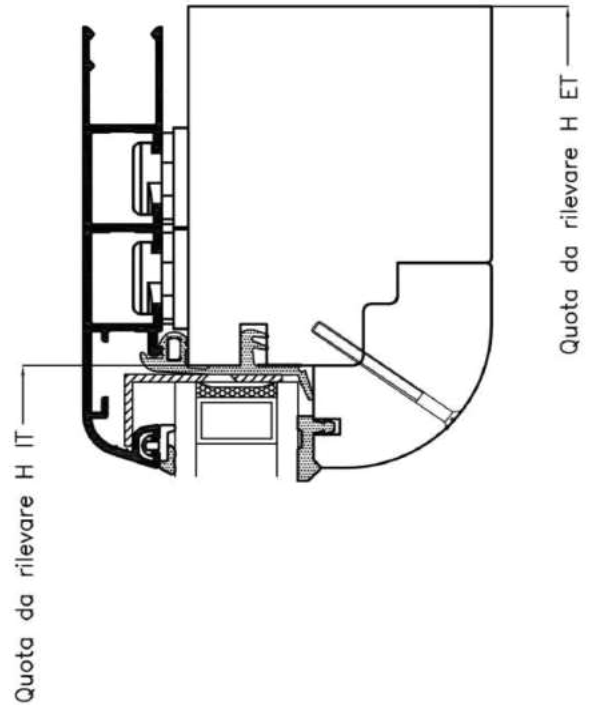

Cliente Standard



REV. 00

**TIPOLOGIE SPECIALI:  
ARCHI & FUORI SQUADRO**

Descrizione: **SCHEMA SEMPLIFICATIVO DI RILEVAMENTO  
MISURE TIPOLOGIE SPECIALI**

PAGINA

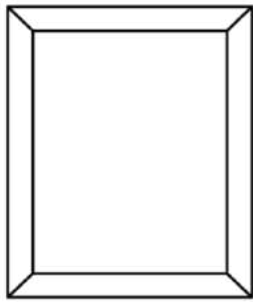

FF

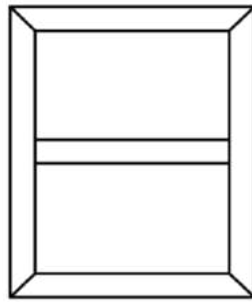

FF\_tt

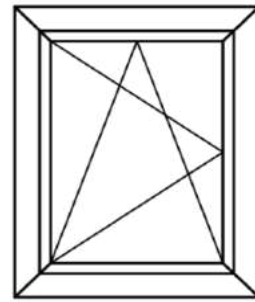

F1A

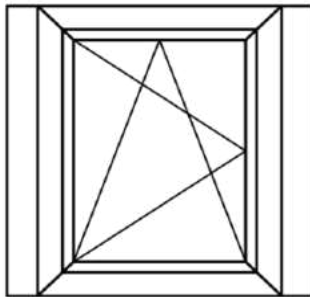

F1A\_gp  
Guida persiana

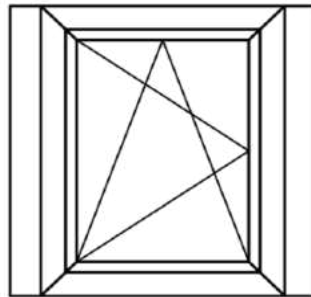

F1A\_gp  
Guida persiana  
Guida zanzariera

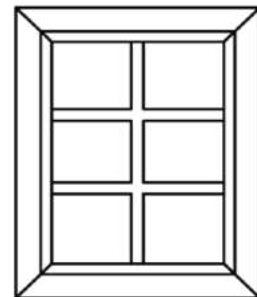

F1A\_ig  
con inglesina

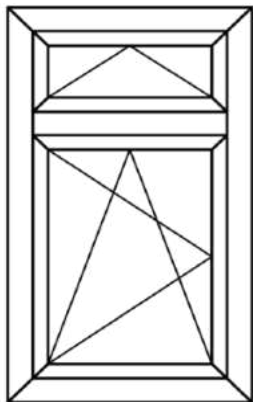

F1A\_soa

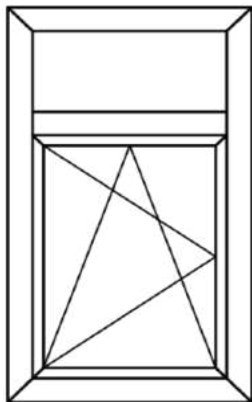

F1A\_sof

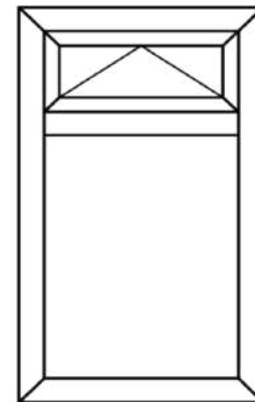

FF\_soa

			File:09s010_060408	Sistema <b>ASTRO 9</b>	09S
	Cliente Standard		REV. 05	Scala Disegno	1:1
Descrizione:			Tolleranze Generali		± 0,5mm
<b>TIPOLOGIE DI SERRAMENTI</b>			PAGINA		
Mod_35_REV01					

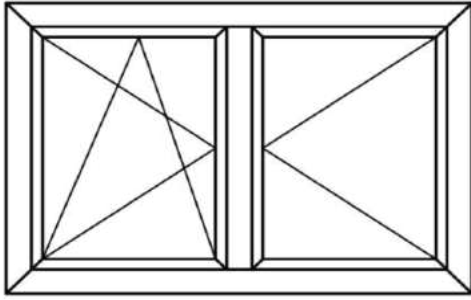

F2A

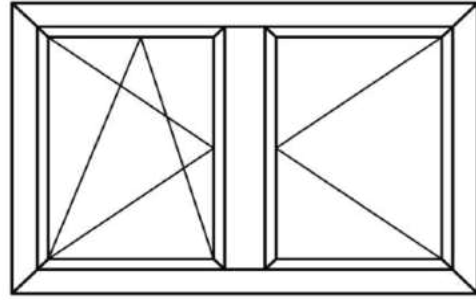

F2A\_mt

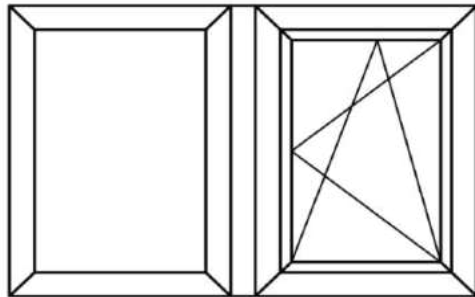

F2A\_aaf

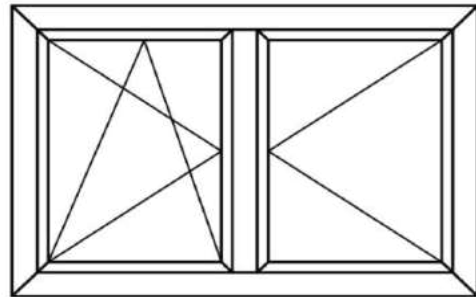

F2A  
Scorrevole parallelo

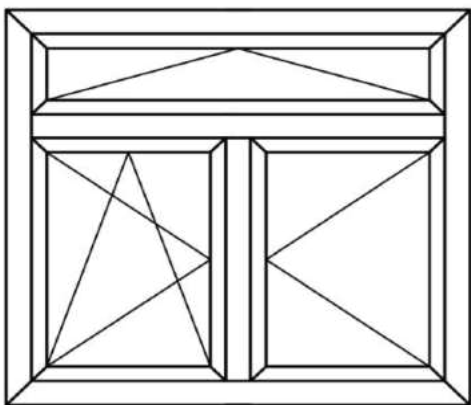

F2A\_soa

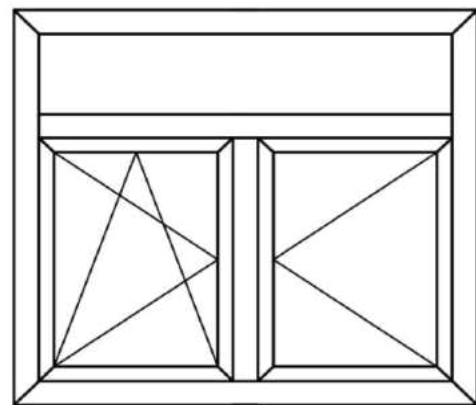

F2A\_sof

			Sistema <b>ASTRO 9</b>	09S
	Cliente Standard		REV. 05	Scala Disegno
Descrizione: <b>TIPOLOGIE DI SERRAMENTI</b>			Tolleranze Generali	± 0,5mm
			PAGINA	
Mod_35_REV01				



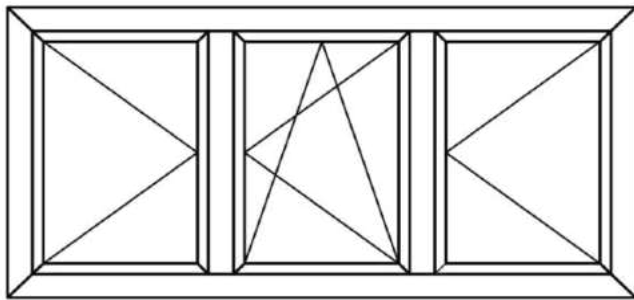

F3A

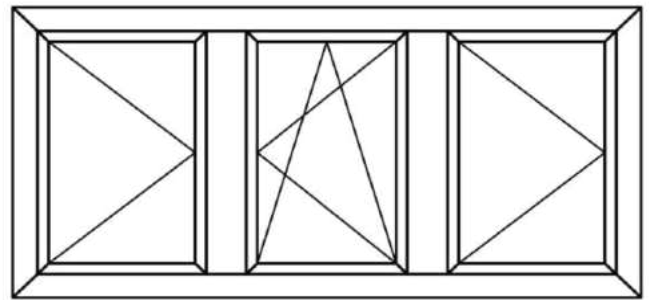

F3A\_mt

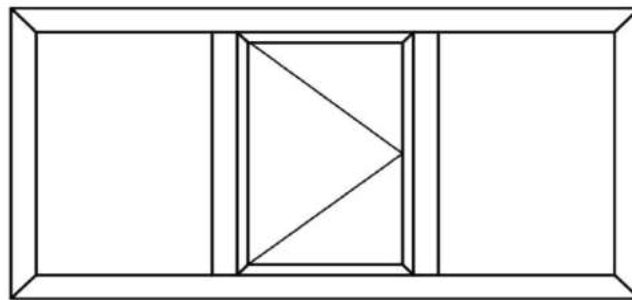

F3A\_aaf

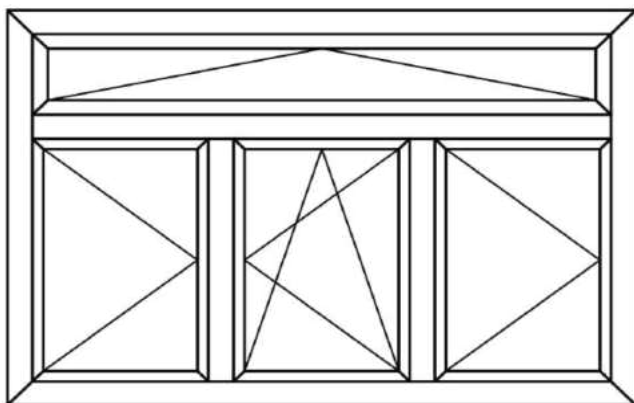

F3A\_soa

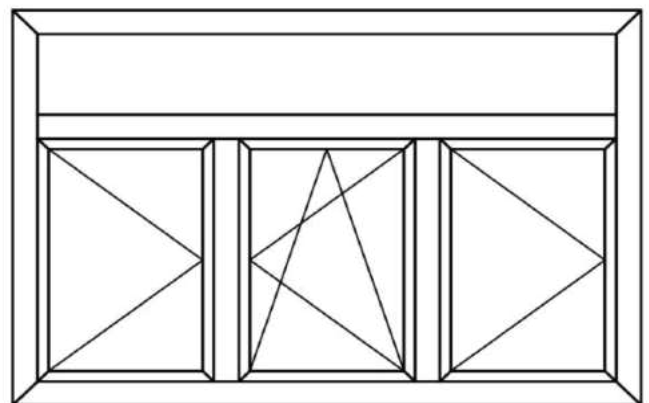

F3A\_sof

				Sistema <b>ASTRO 9</b> 09S
	Cliente Standard		REV. 05	Scala Disegno 1:1
Descrizione: <b>TIPOLOGIE DI SERRAMENTI</b>				Tolleranze Generali ± 0,5mm
Mod_35_REV01				PAGINA

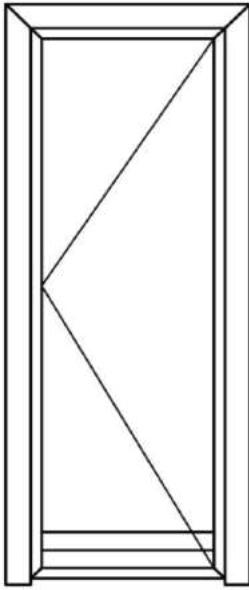

PF1A\_z2

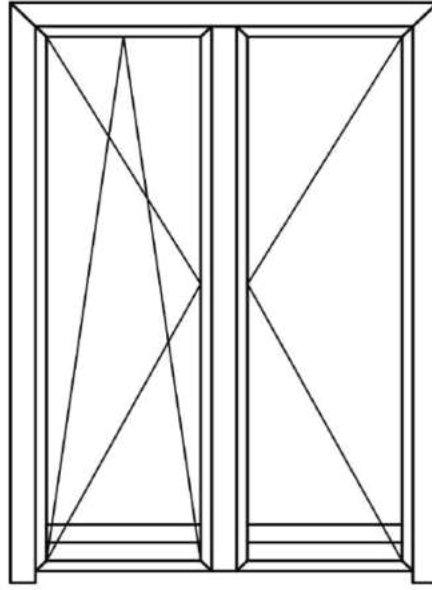

PF2A\_z2

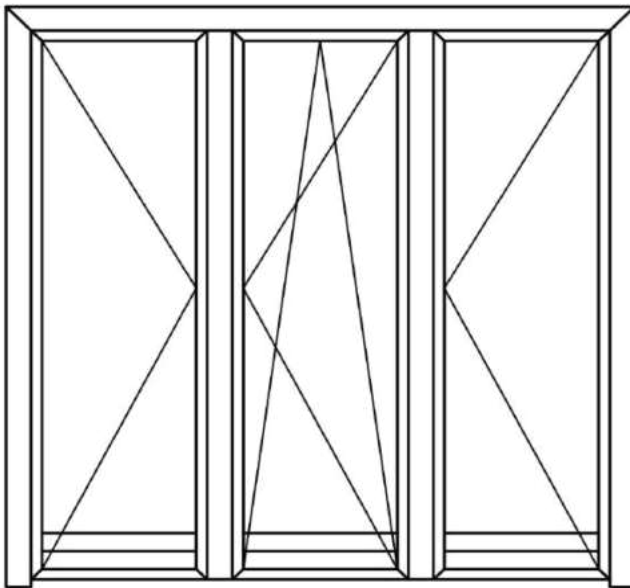

PF3A\_z2

Porta finestra  
variante parafreddo

				Sistema <b>ASTRO 9</b> 09S
	Cliente Standard		REV. 05	Scala Disegno 1:1
Descrizione:				Tolleranze Generali ± 0,5mm
<b>TIPOLOGIE DI SERRAMENTI</b>				PAGINA
Mod_35_REV01				

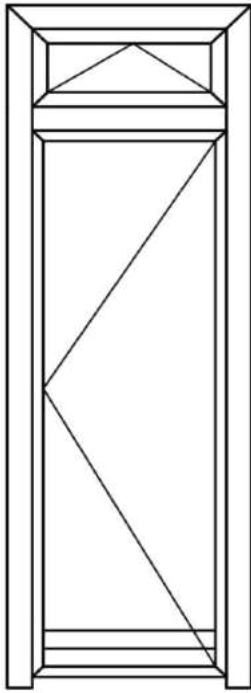

PF1A\_soa\_z2

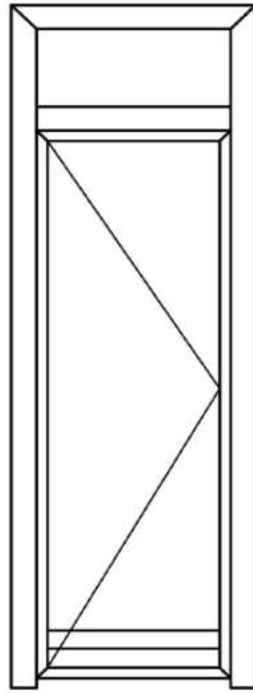

PF1A\_sof\_z2

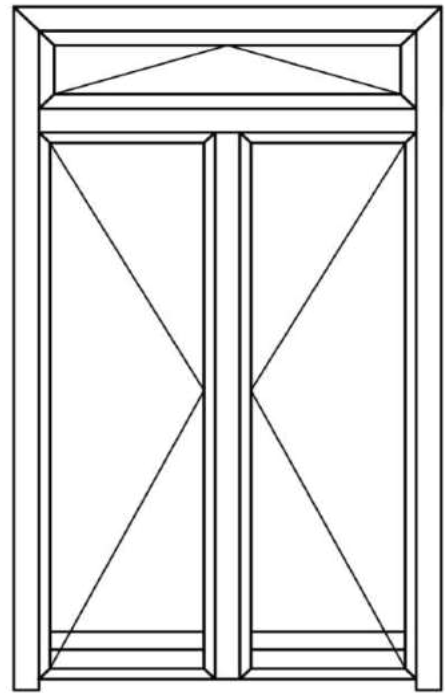

PF2A\_soa\_z2

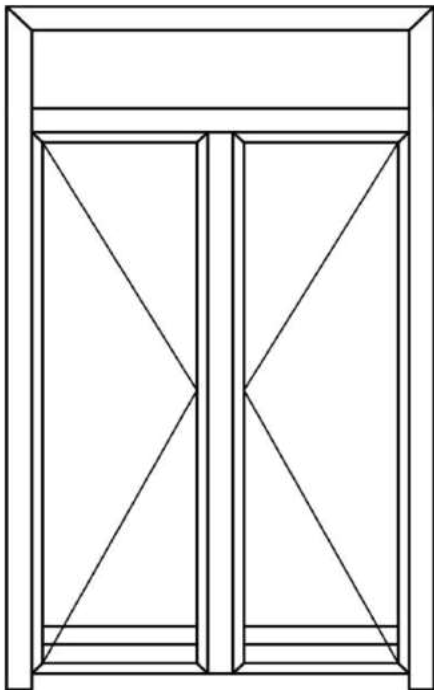

PF2A\_sof\_z2

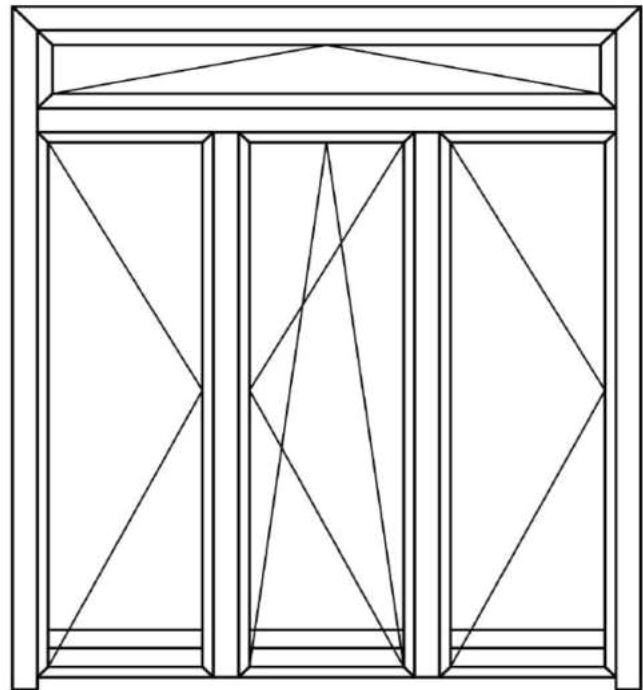

PF3A\_soa\_z2

			Sistema <b>ASTRO 9</b>	09S
	Cliente Standard		REV. 05	Scala Disegno
Descrizione: <b>TIPOLOGIE DI SERRAMENTI</b>			Tolleranze Generali	± 0,5mm
			PAGINA	—
Mod_35_REV01				

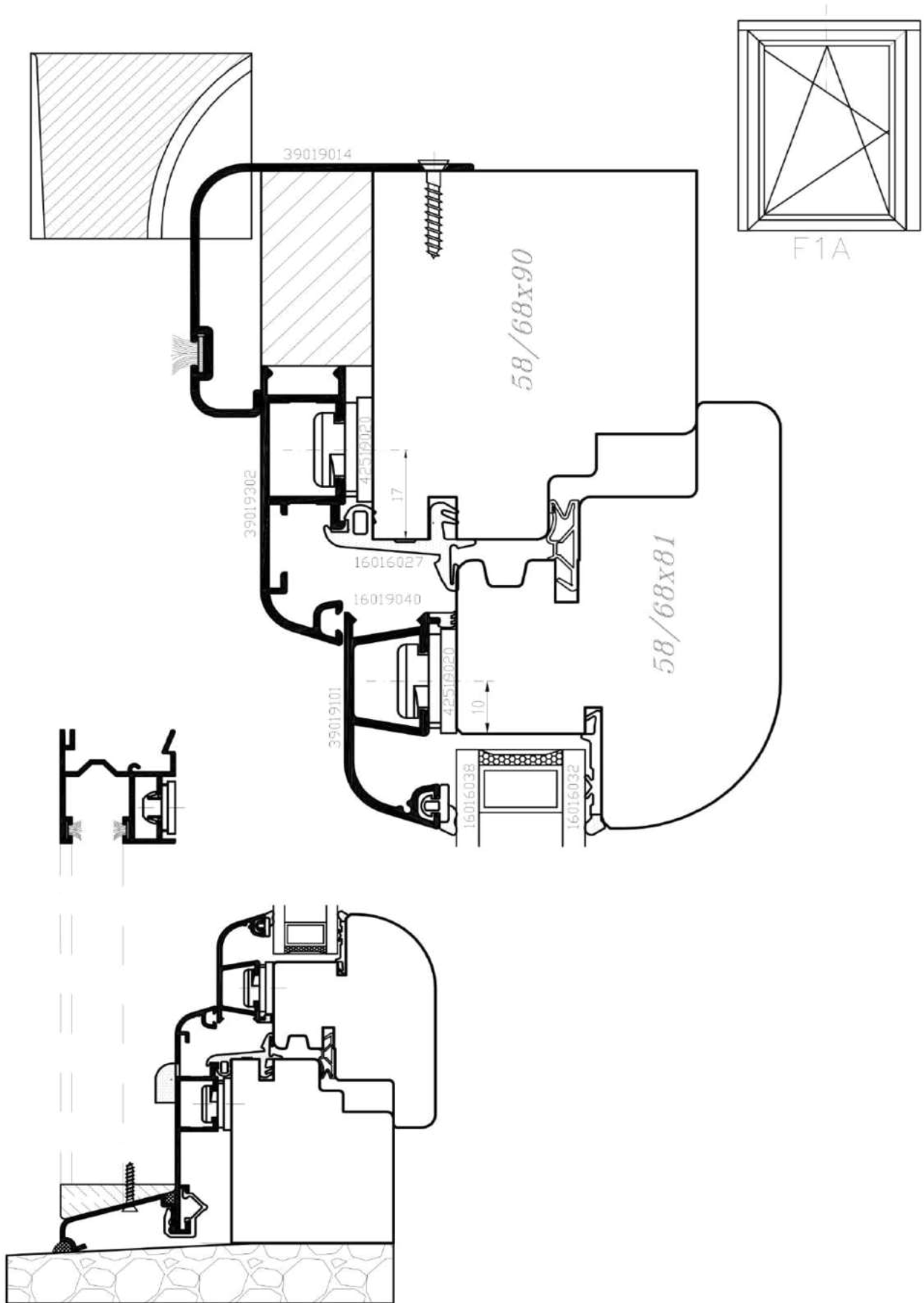

	Cliente Standard		REV. 00	Sistema <b>ASTRO 9</b> 09S
Descrizione: <b>SEZIONE VERTICALE TRAVERSO SUPERIORE FINESTRA</b>				Scala Disegno 1:1
Mod_35_REV01				Tolleranze Generali ± 0,5 mm
				PAGINA

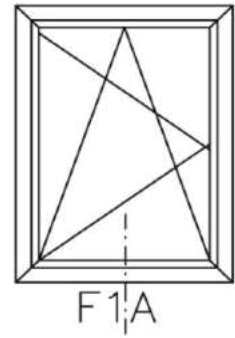

Tappo per scarico acqua  
cod. 81419024

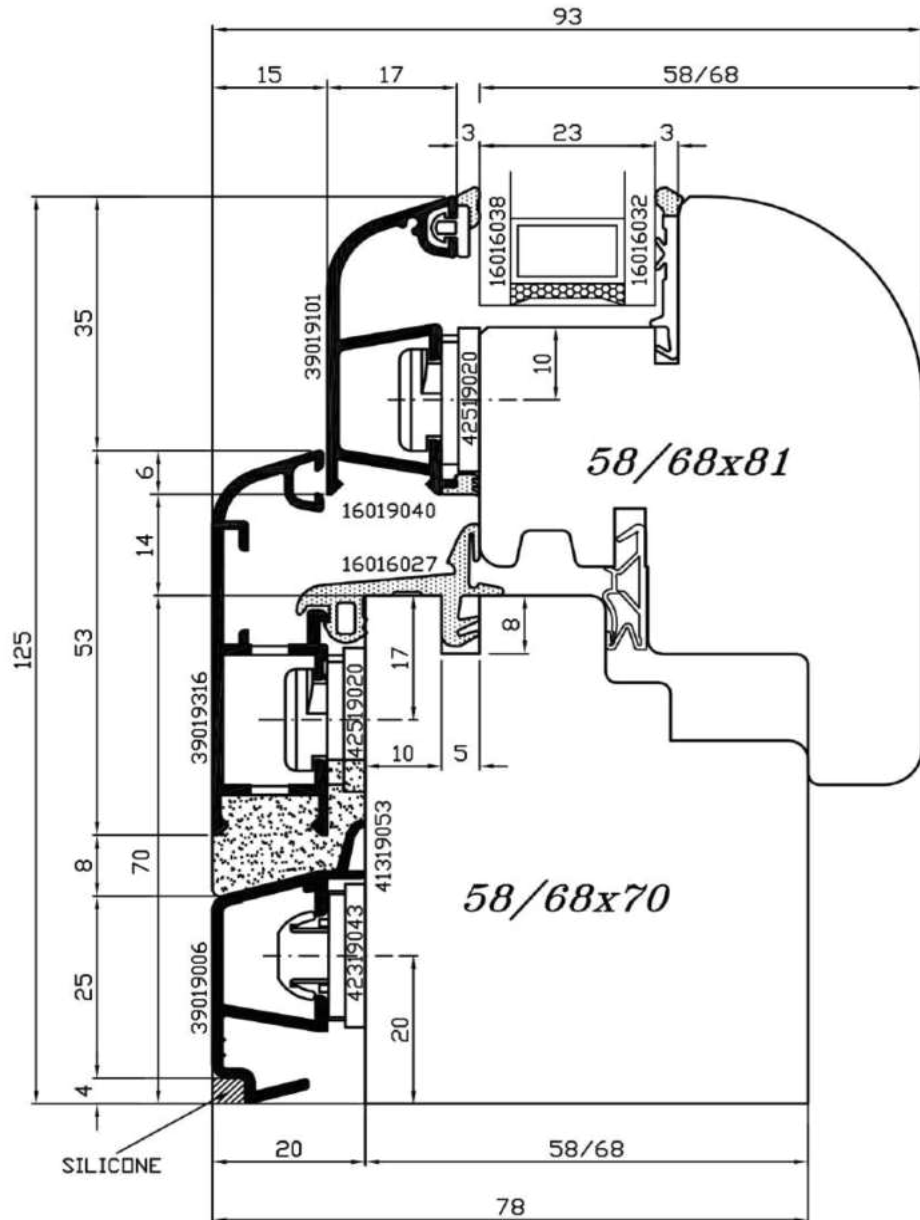
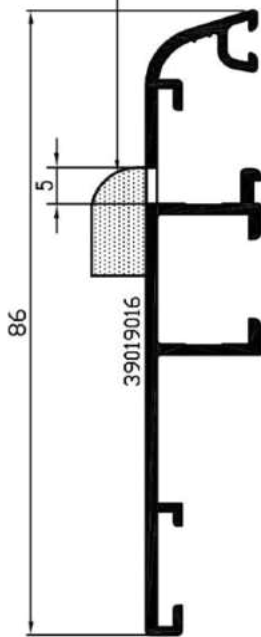

			Sistema <b>ASTRO 9</b>	09S
Ciente Standard			REV. 04	Scala Disegno
Descrizione: <b>SEZIONE VERTICALE TRAVERSO INFERIORE FINESTRA</b>			Tolleranze Generali	± 0,5 mm
			PAGINA	

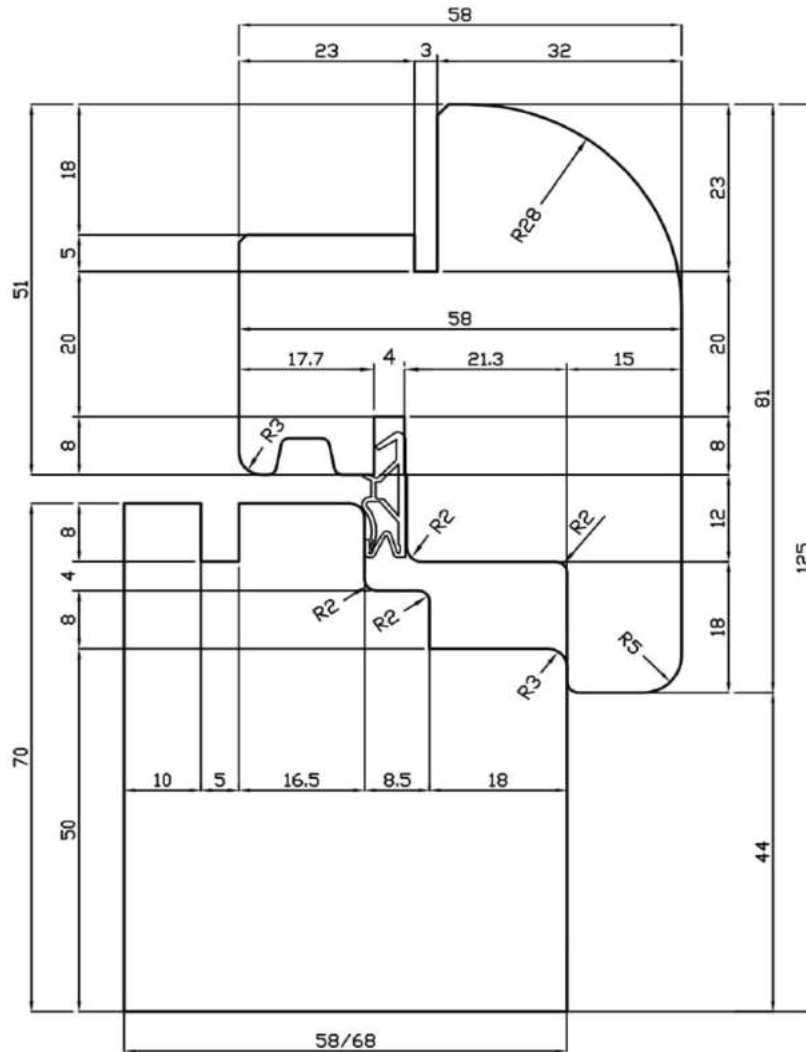
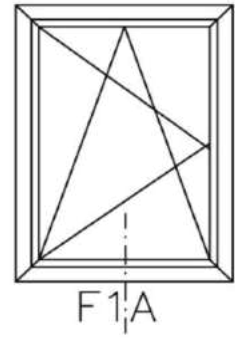

			Sistema <b>ASTRO 9</b>	09S
	Ciente Standard		REV. 04	Scala Disegno
Descrizione: <b>SEZIONE VERTICALE TRAVERSO INFERIORE FINESTRA</b>			Tolleranze Generali	± 0,5 mm
			PAGINA	

Mod\_35\_REV01





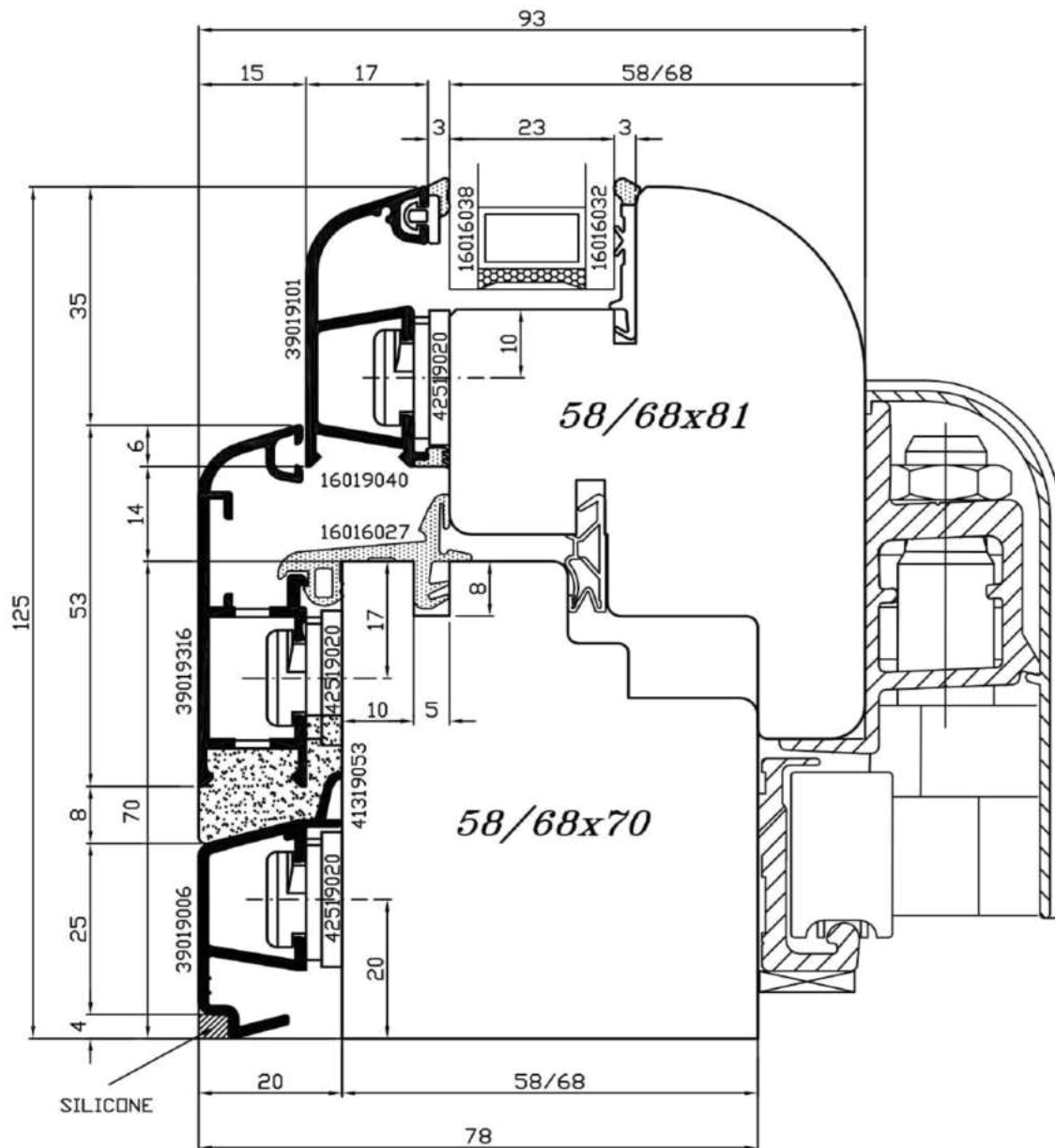
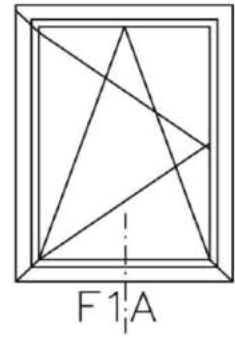

			Sistema <b>ASTRO 9</b>	09S
	Cliente Standard		REV. 04	Scala Disegno
Descrizione: <b>SEZIONE VERTICALE TRAVERSO INFERIORE CON GUIDA INFERIORE PER SCORREVOLE PARALLELO</b>			Tolleranze Generali	± 0,5 mm
			PAGINA	

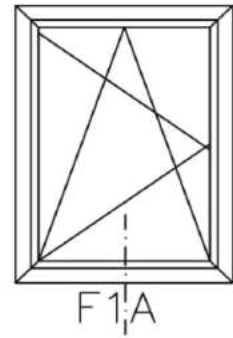

Tappo per scarico acqua  
cod. 81419024

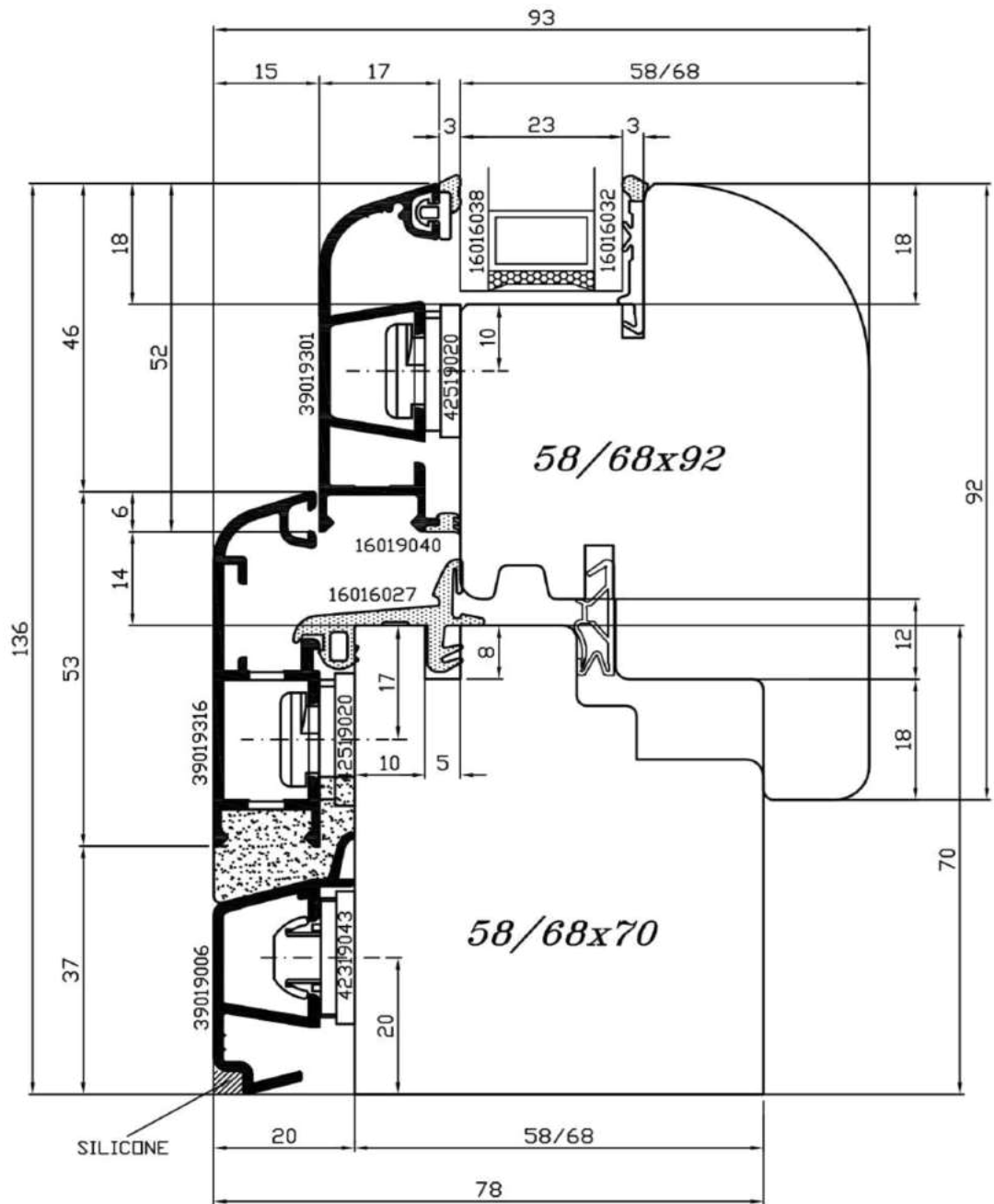
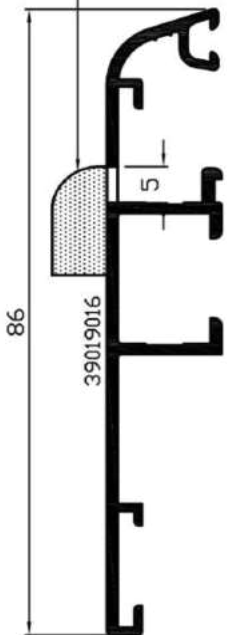

			Sistema <b>ASTRO 9</b>	09S
	Cliente Standard		REV. 00	Scala Disegno 1:1
Descrizione: <b>SEZIONE VERTICALE TRAVERSO INFERIORE FINESTRA</b>			Tolleranze Generali	± 0,5 mm
Mod_35_REV01			PAGINA	

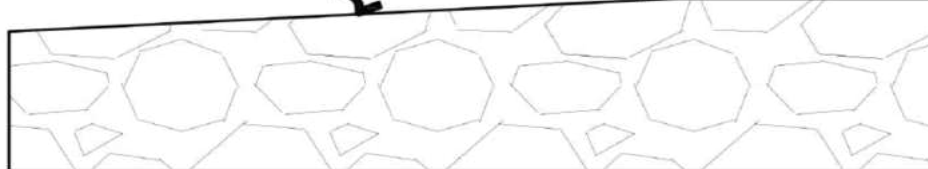
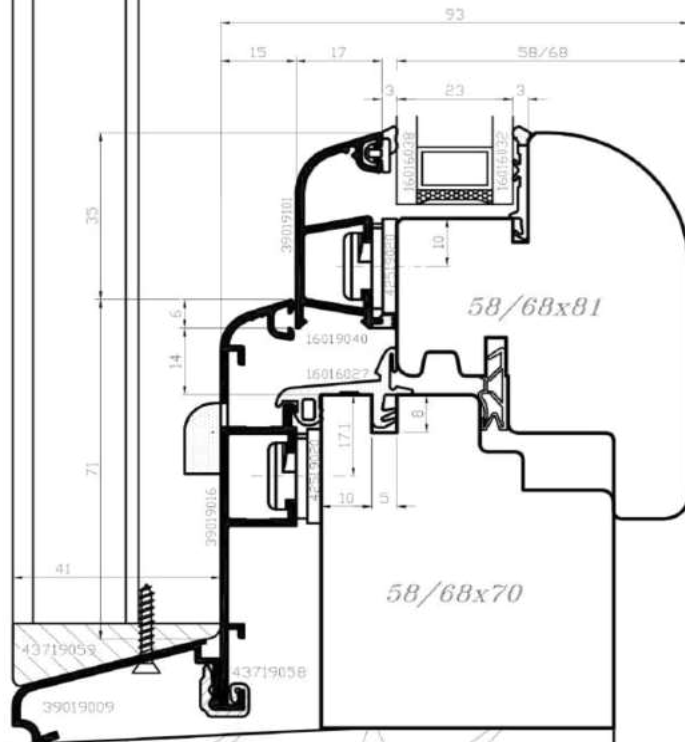
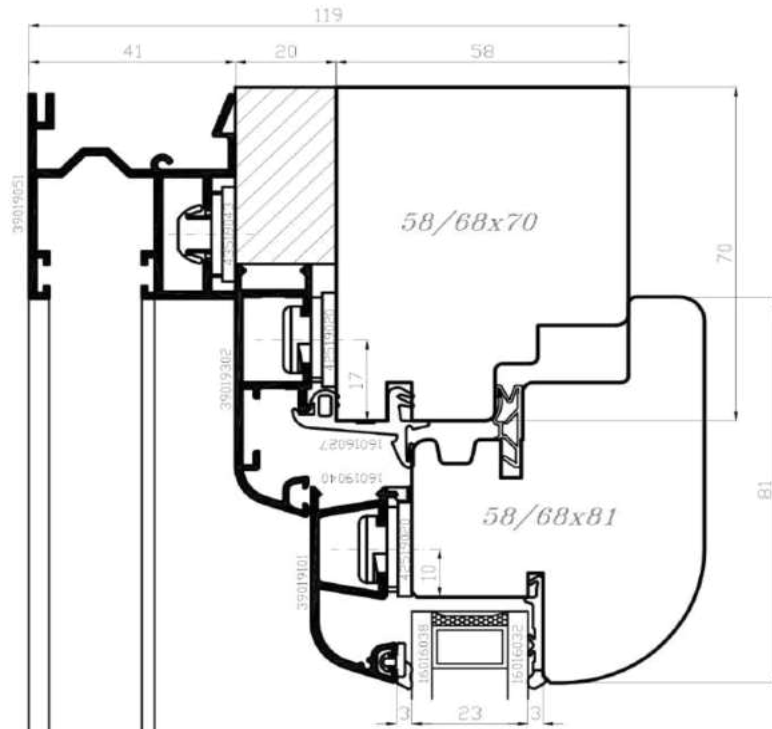
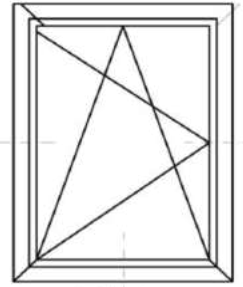

	Cliente Standard		REV. 00	Sistema <b>ASTRO 9</b> 09S
Descrizione:	<b>SEZIONE VERTICALE GUIDA PERSIANA E BANCALINO</b>			Scala Disegno Fuori Scala
				Tolleranze Generali ± 0,5 mm
Mod_35_REV01				PAGINA



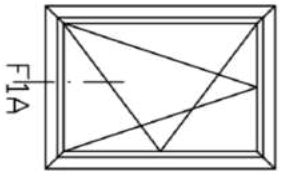

DISEGNO FUORI SCALA

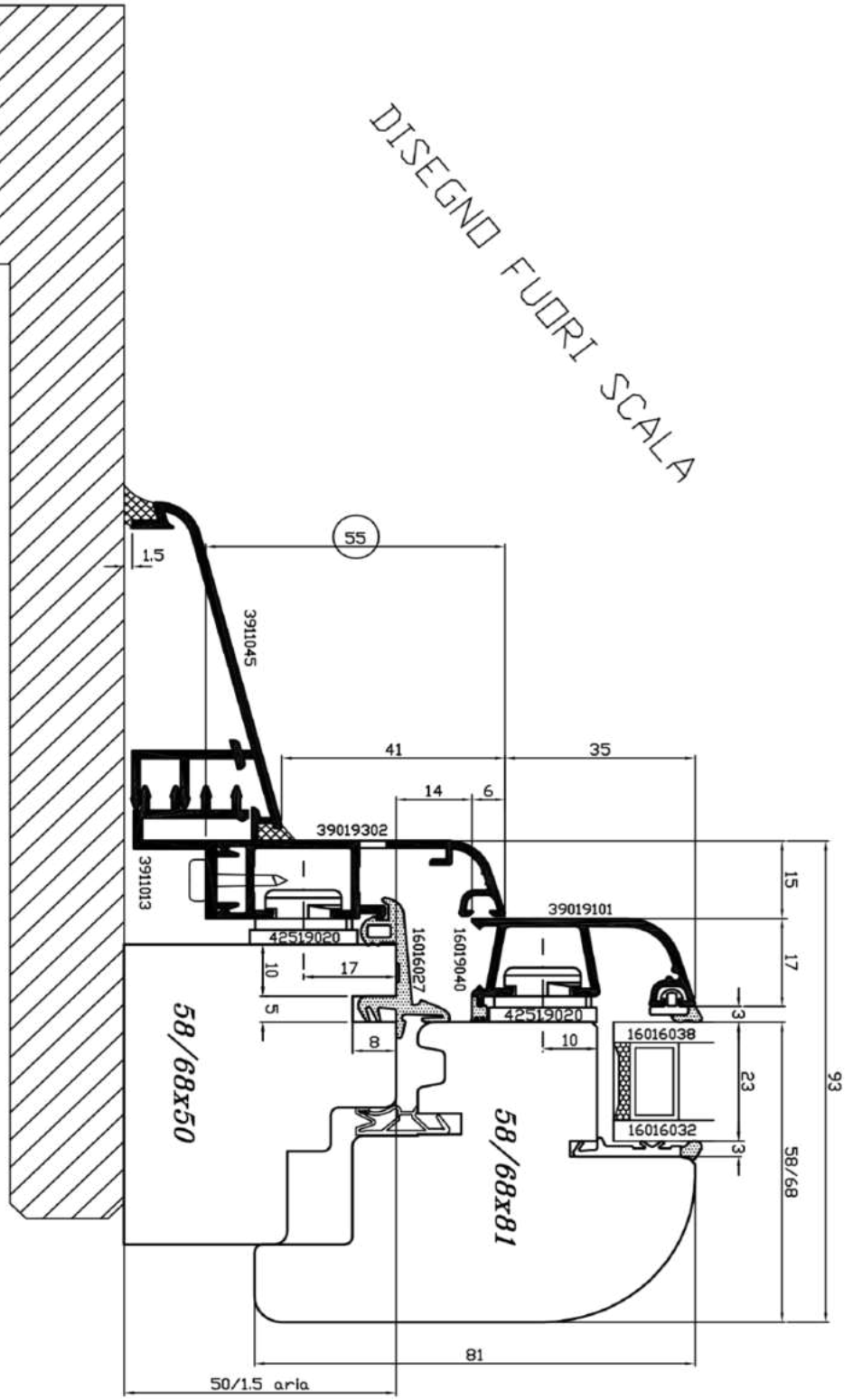

Descrizione: <b>SEZIONE VERTICALE SNODO          INFERIORE CON BANCALINO</b>			
Cliente Standard	REV. 04	Sistema <b>ASTRO 9</b>	095
Mod. 35_REV01	Tolleranze Generali ± 0,5 mm	Scala Disegno	Fuori Scala
PAGINA			



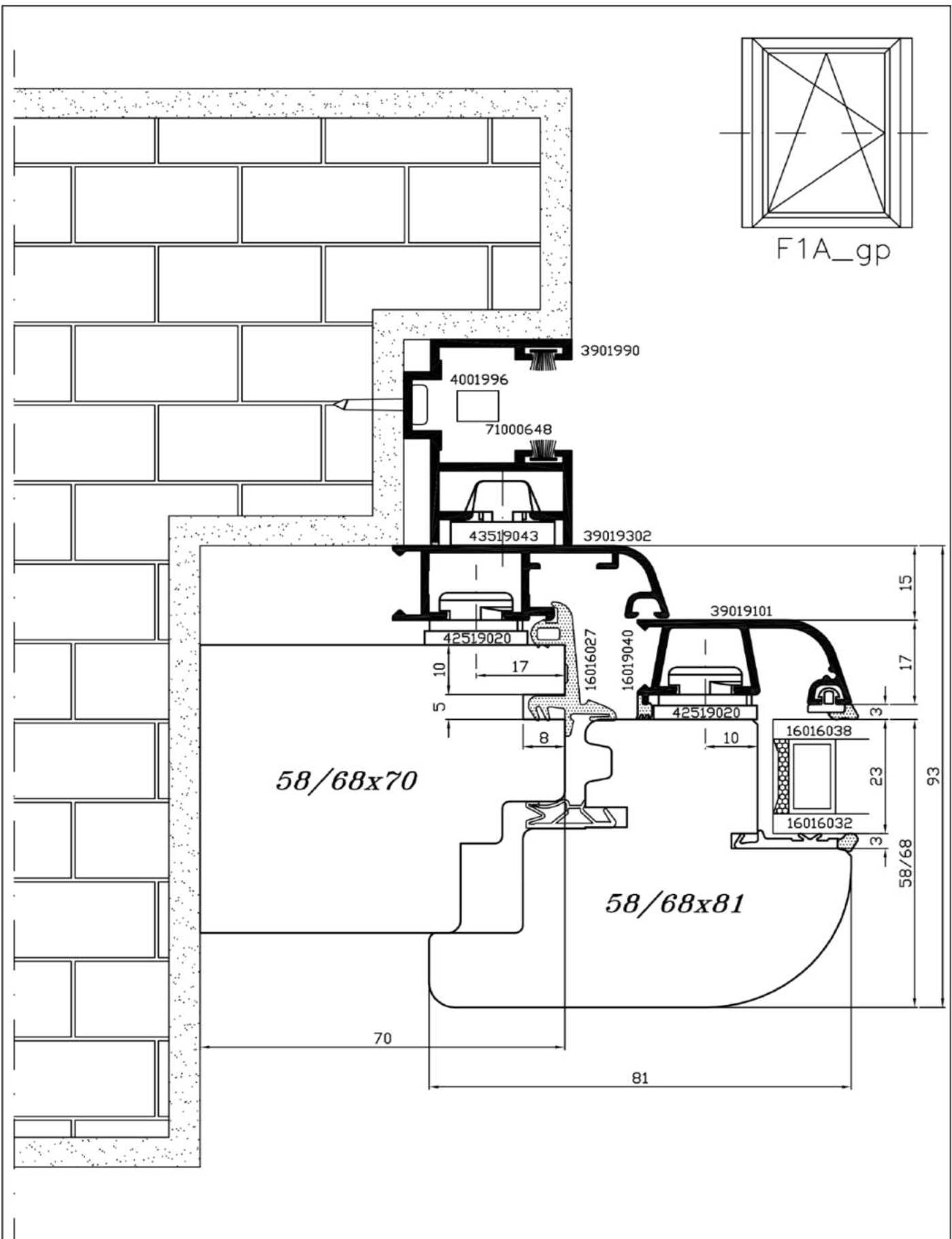
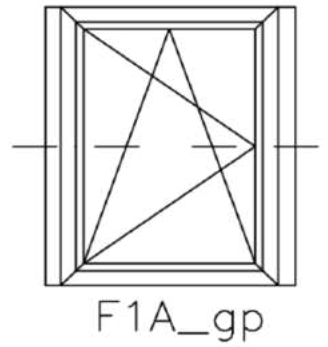

Cliente Standard		REV. 00	Sistema <b>ASTRO 9</b> 09S
Descrizione:			Scala Disegno 1:1
<b>SEZIONE ORIZZONTALE CON GUIDA PERSIANA</b>			Tolleranze Generali ± 0,5 mm
Mod_35_REV01			PAGINA <b>304v7</b>



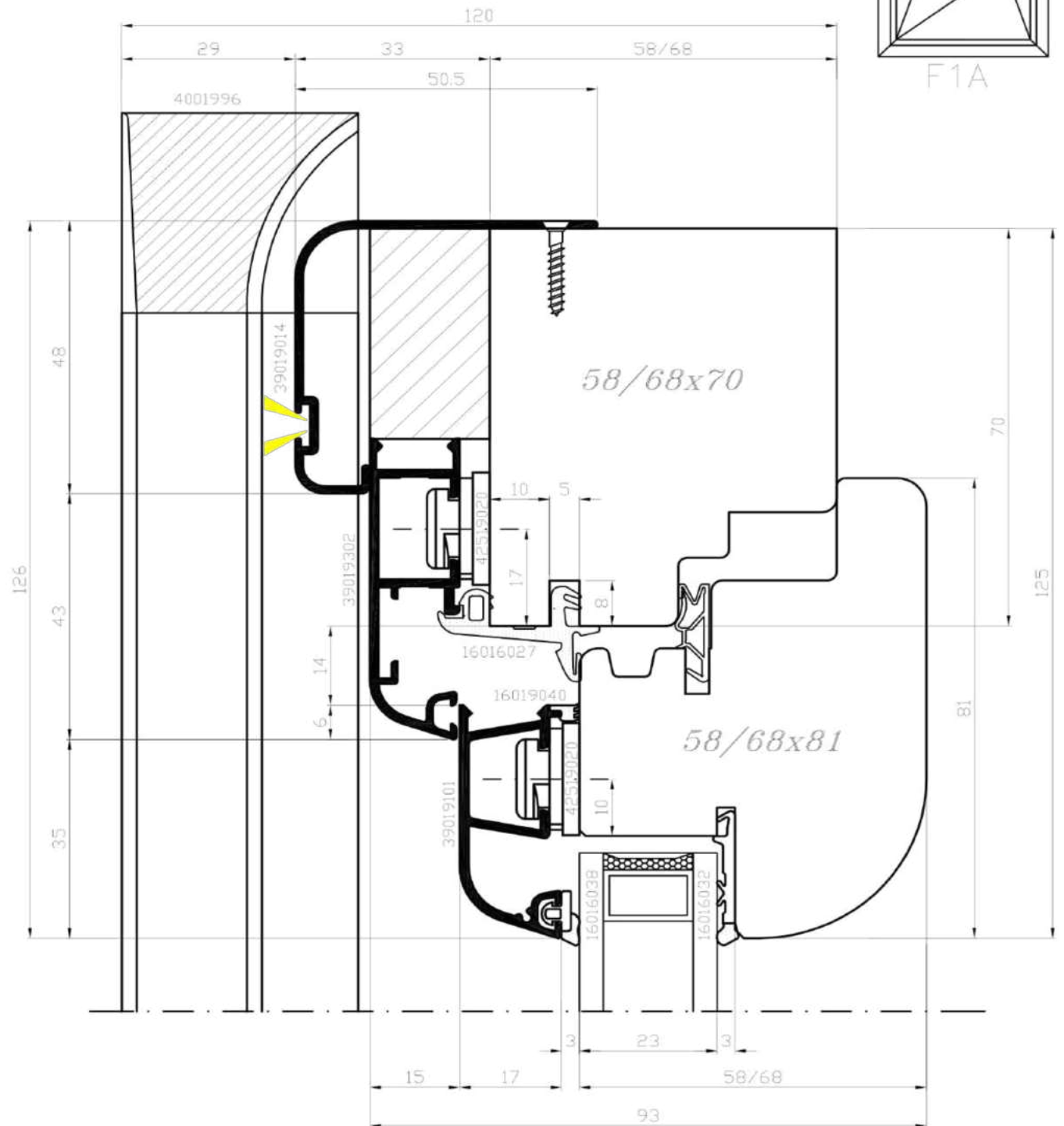
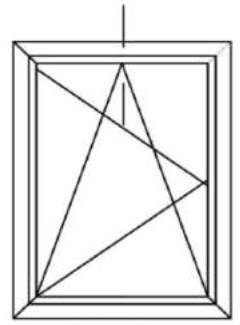

			Sistema <b>ASTRO 9</b>	09S
	Cliente Standard		REV. 00	Scala Disegno
Descrizione: <b>SEZIONE VERTICALE TRAVERSO SUPERIORE FINESTRA</b>			Tolleranze Generali	± 0,5 mm
			PAGINA	
Mod_35_REV01				

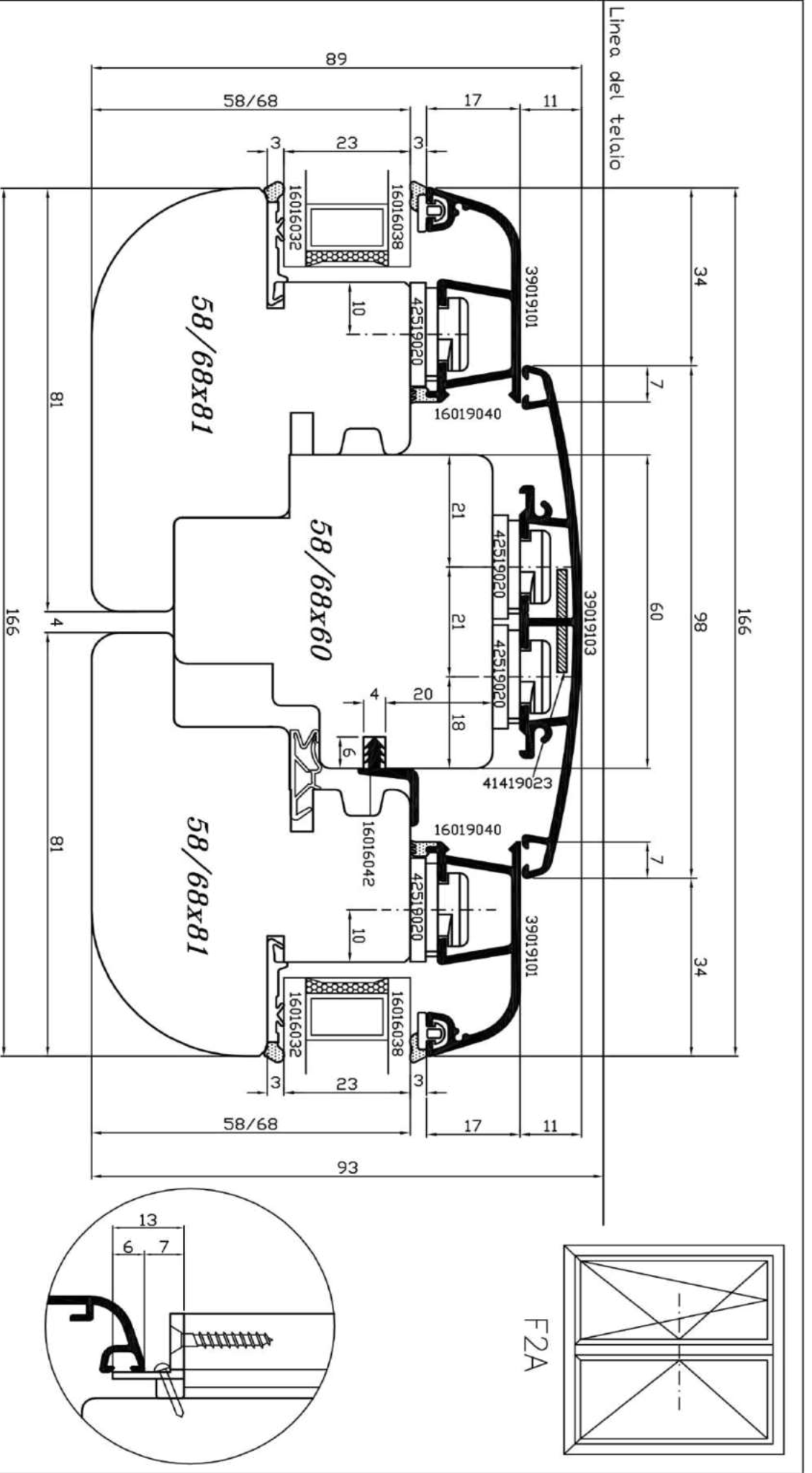

Linea del telaio

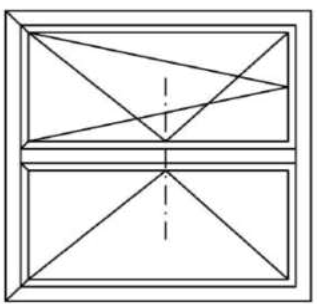

F2A

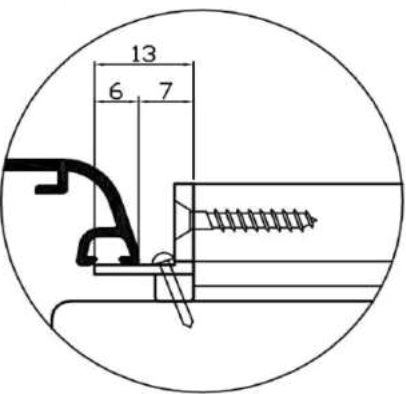

Descrizione: <b>SEZIONE ORIZZONTALE          SNODO CENTRALE</b>			
Cliente Standard	REV. 04	Sistema <b>ASTRO 9</b>	09S
Mod. 35_REV01	Tolleranze Generali ± 0,5 mm	Scala Disegno 1:1	PAGINA

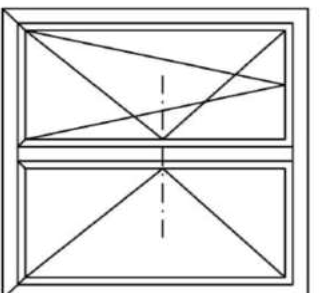
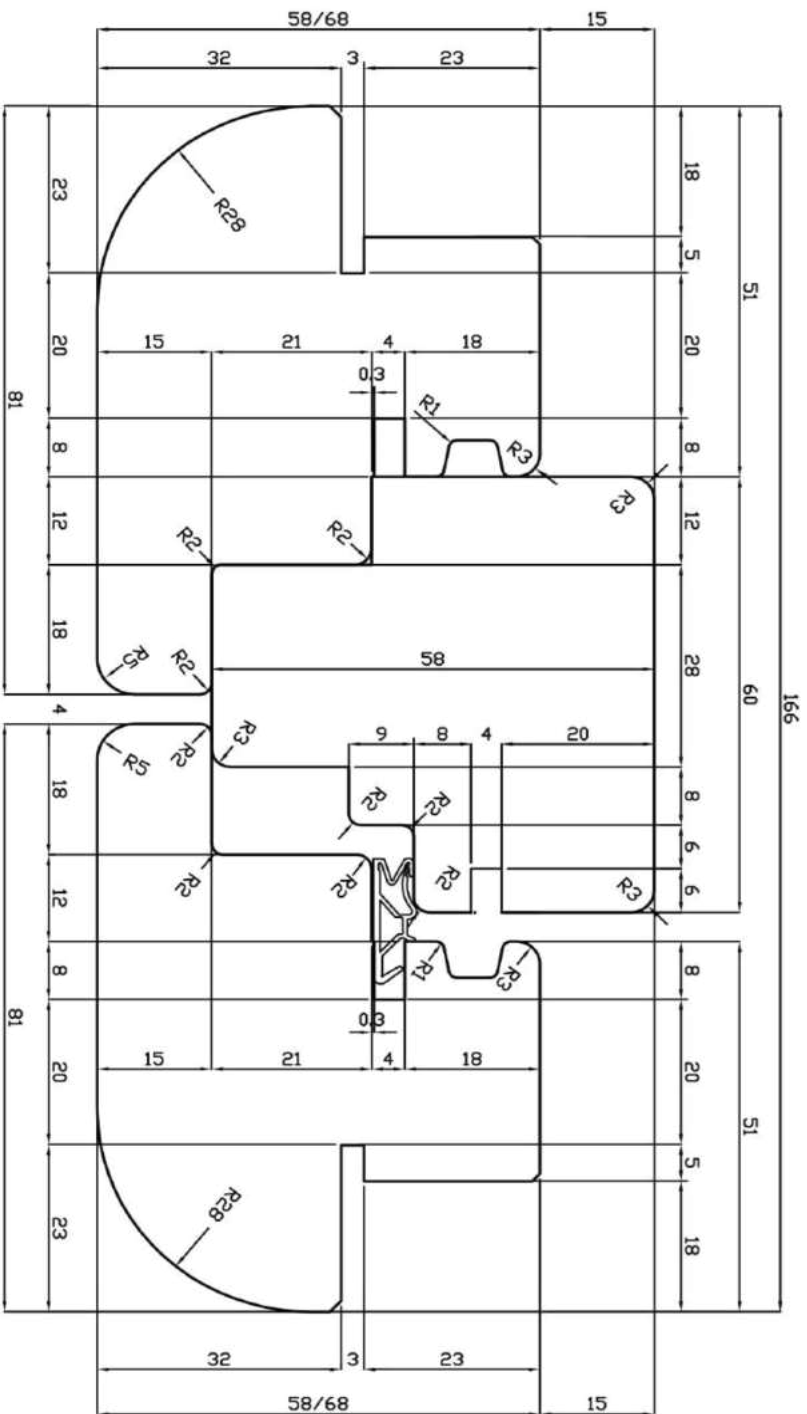

F2A

Descrizione: <b>SEZIONE ORIZZONTALE          SNODO CENTRALE</b>			
Cliente Standard	REV. 04	Sistema <b>ASTRO 9</b>	09S
Mod. 35_REV01	Tolleranze Generali ± 0,5 mm	Scala Disegno 1:1	09S
PAGINA		09S	

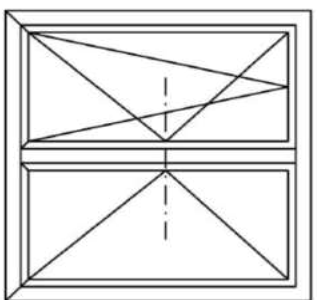
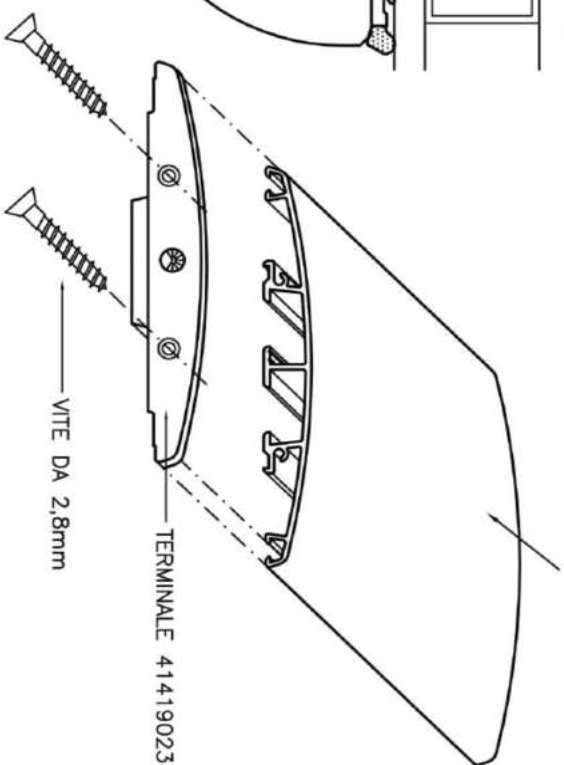
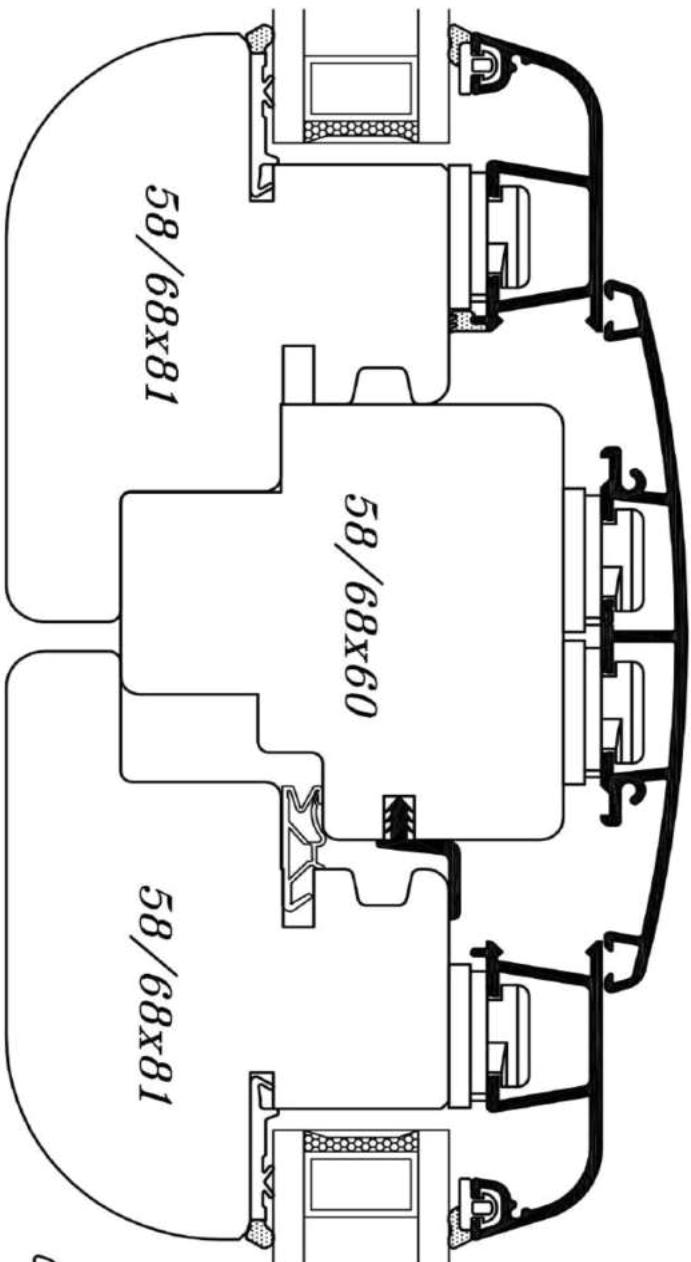

MONTANTINO  
CENTRALE  
COD. 39019103

F2A

Descrizione: <b>MONTAGGIO DEL TERMINALE</b> <b>COD. 41419023</b>				Cliente Standard	REV. 04	Sistema <b>ASTRO 9</b> 09S	Scala Disegno 1:1
Mod. 35_REV01		Tolleranze Generali ± 0,5 mm		PAGINA		PAGINA	



Linea del telaio

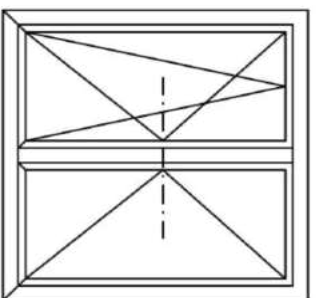
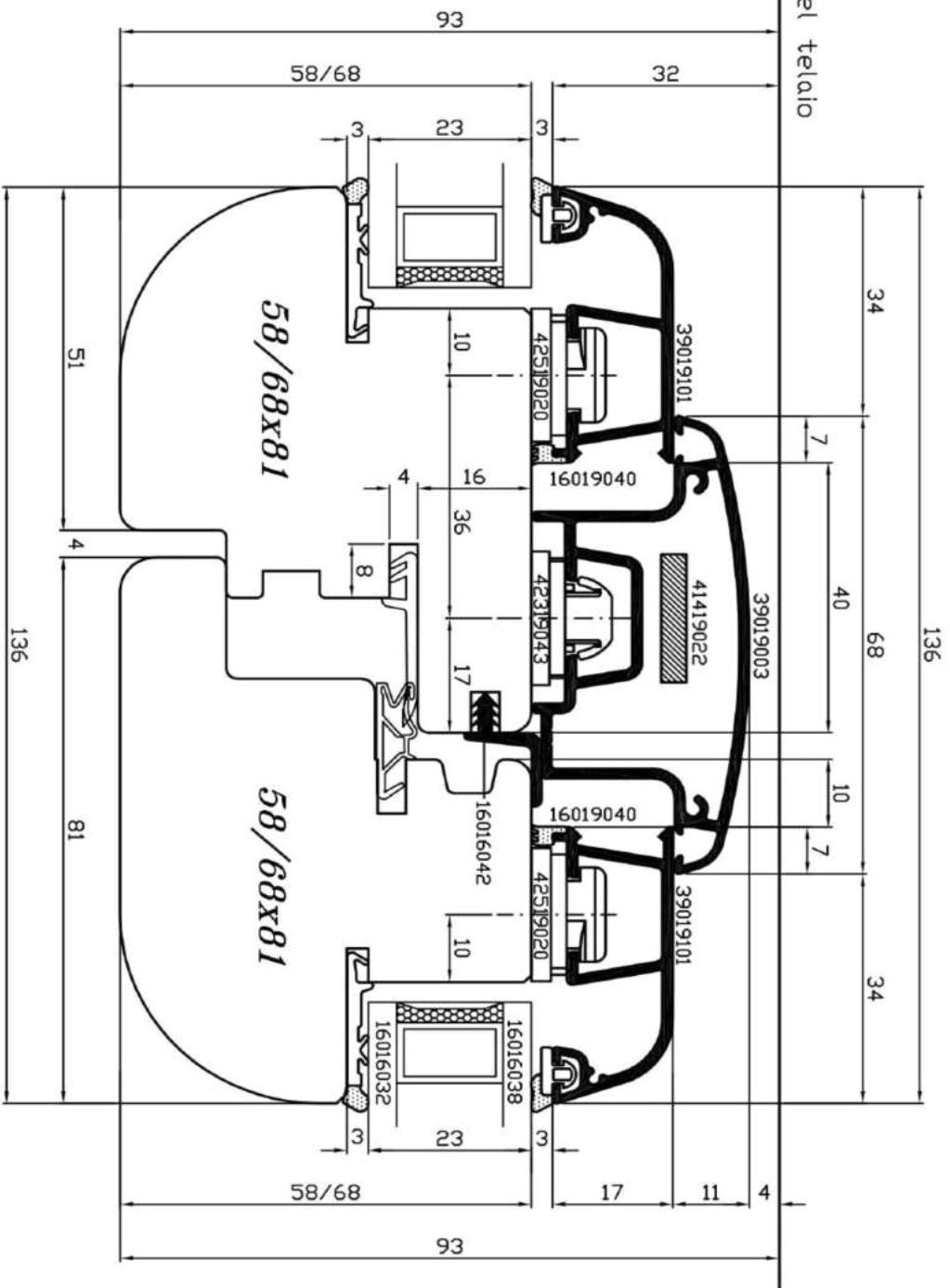

F2A

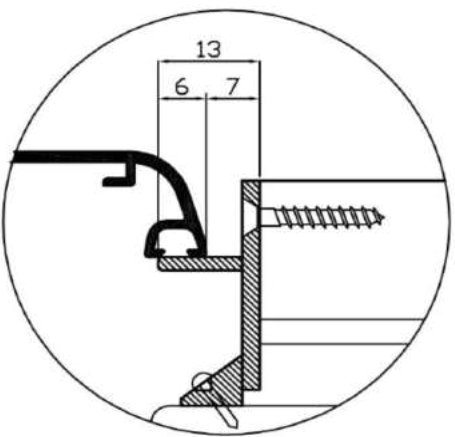

Sistema <b>ASTRO 9</b>		09S
Scala Disegno		1:1
Tolleranze Generali		± 0,5 mm
PAGINA		
REV. 04		

Cliente Standard



Descrizione:

**SEZIONE ORIZZONTALE  
SNODO CENTRALE**

Mod. 35\_REV01

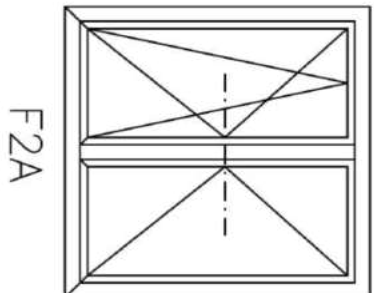
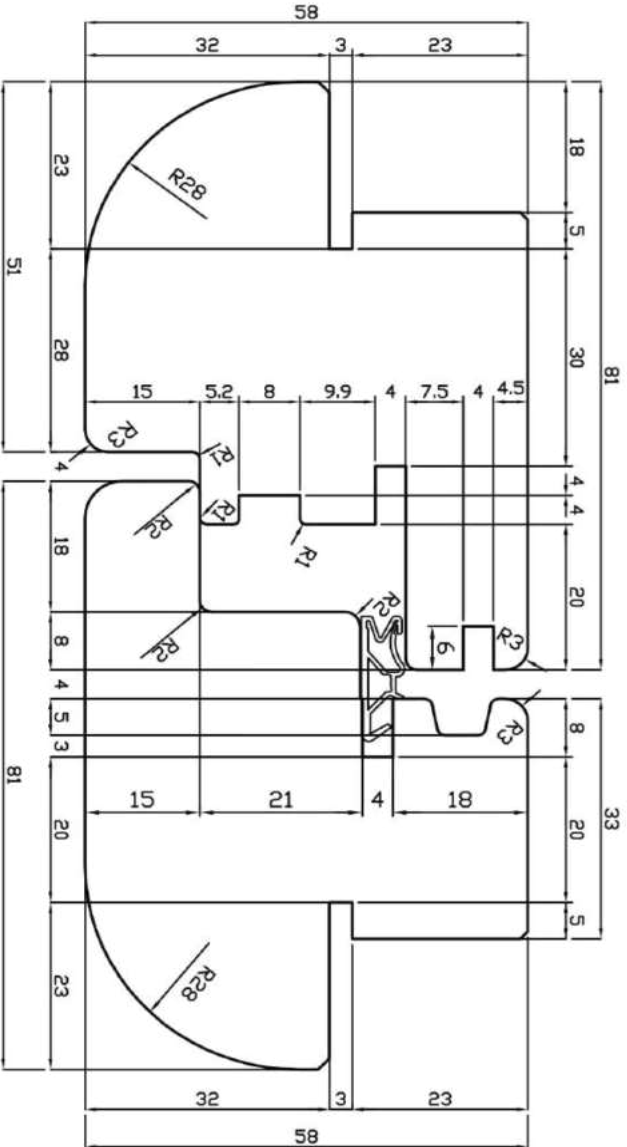

Descrizione: <b>SEZIONE ORIZZONTALE          SNODO CENTRALE</b>			
Cliente	Standard	REV.	04
Sistema <b>ASTRO 9</b>		09S	
Scala Disegno	1:1	Tolleranze Generali	± 0,5 mm
PAGINA			
Mod. 35_REV01			

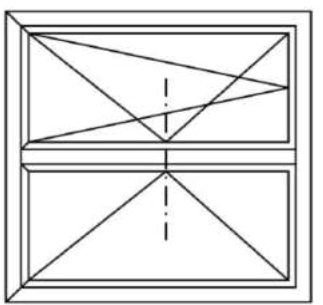
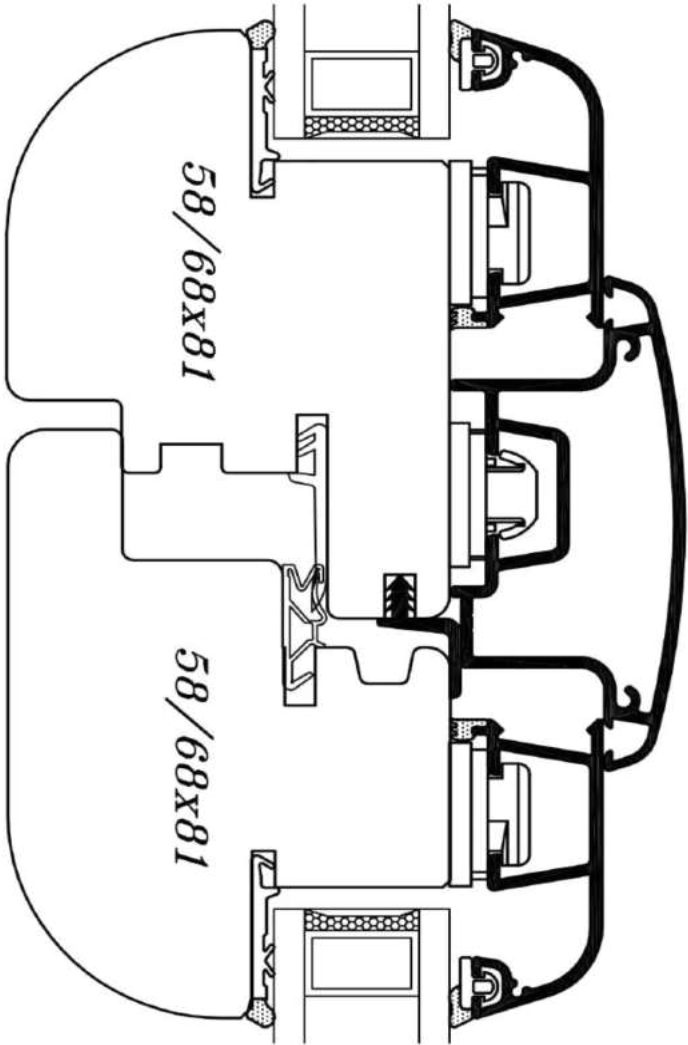

F2A

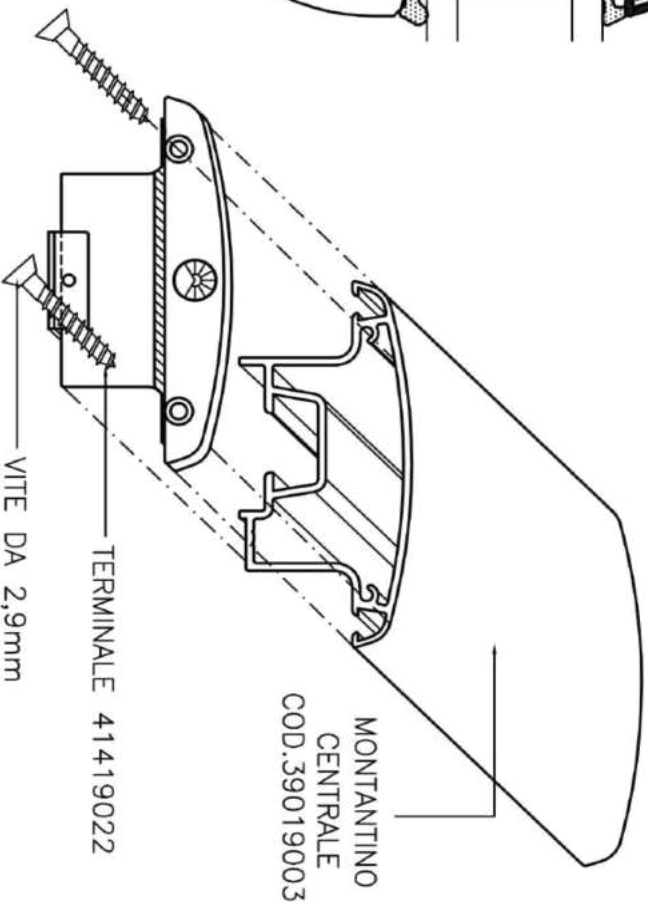

MONTANTINO  
CENTRALE  
COD.39019003

TERMINALE 41419022

VITE DA 2,9mm

<p>Descrizione:</p> <p><b>MONTAGGIO DEL TERMINALE</b></p> <p><b>COD. 41419022</b></p>		<p>Mod. 35_REV01</p>	
<p>Cliente Standard</p>		<p>REV. 04</p>	<p>Sistema <b>ASTRO 9</b> 09S</p>
<p>Scala Disegno 1:1</p>	<p>Tolleranze Generali ± 0,5 mm</p>	<p>PAGINA</p>	<p>09S</p>

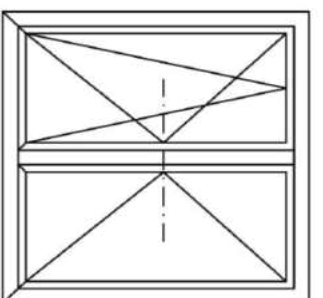
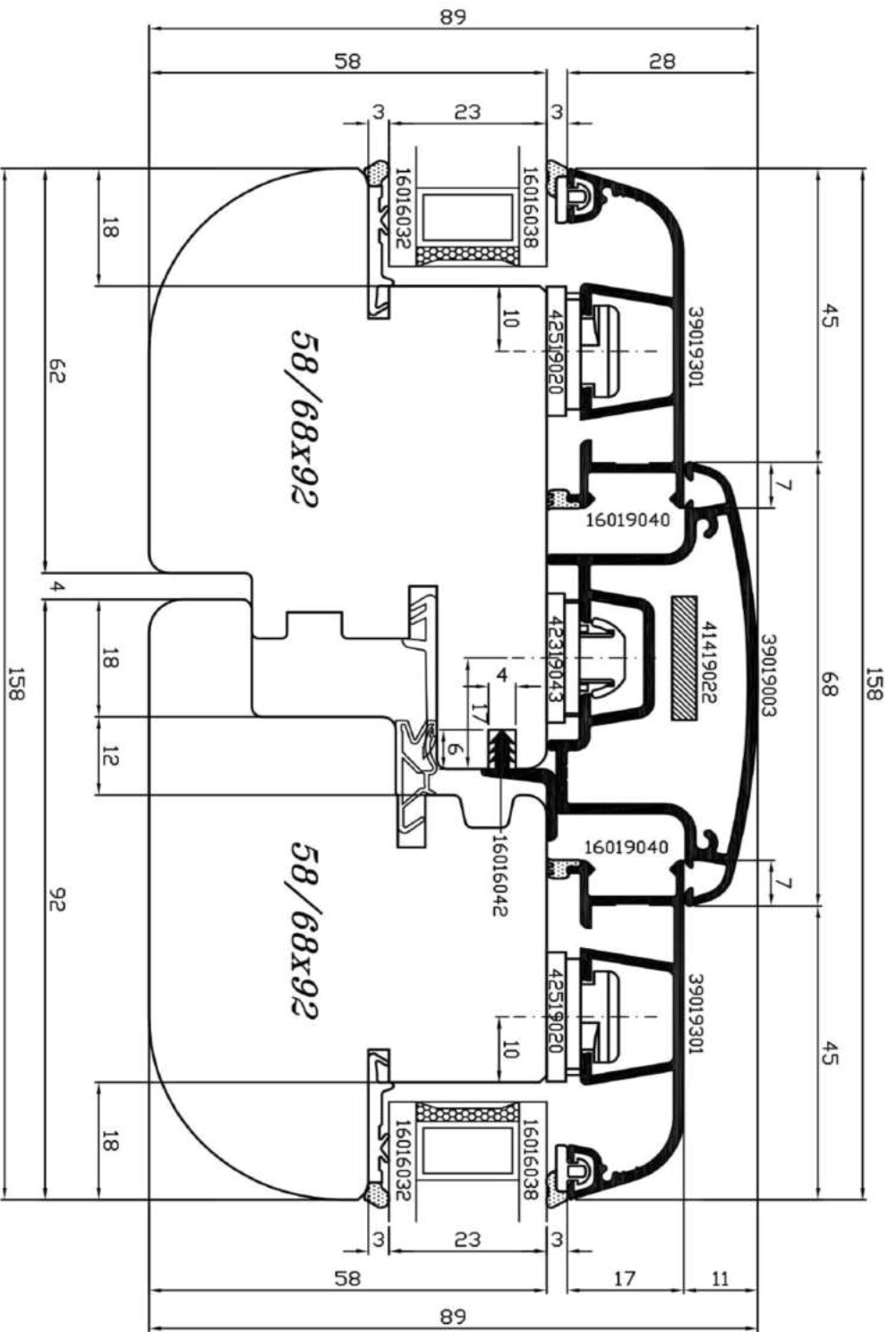

F2A

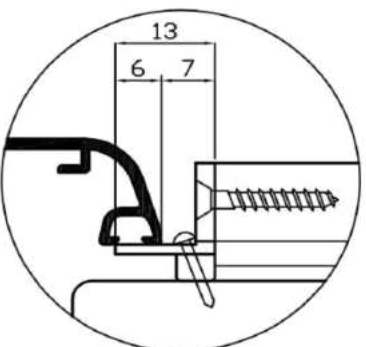

Descrizione: <b>SEZIONE ORIZZONTALE SNODO CENTRALE</b>			
Cliente Standard		REV. 00	
Sistema <b>ASTRO 9</b> 095		Scala Disegno	1:1
Tolleranze Generali ± 0,5 mm		PAGINA	
Mod. 35_RE01			

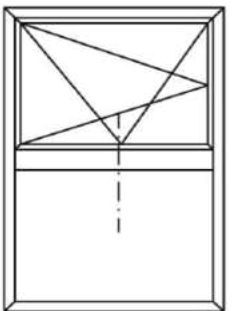
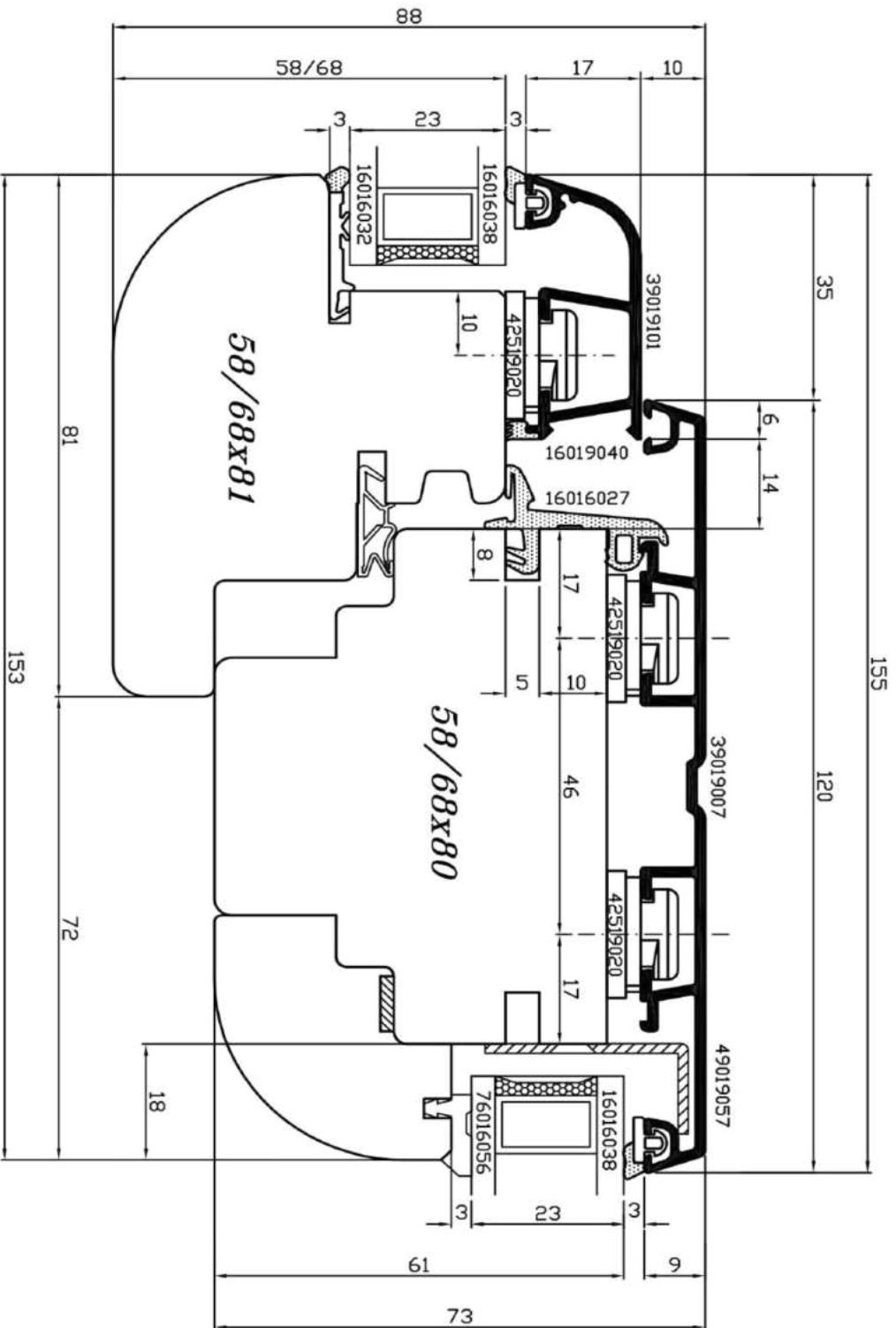

F2A\_af\_mt

Descrizione: <b>SEZIONE ORIZZONTALE MONTANTE FINESTRA APRIBILE-FISSO</b>			
Cliente Standard		REV. 05	
Sistema <b>ASTRO 9</b>		095	
Scala Disegno		1:1	
Tolleranze Generali		± 0,5 mm	
PAGINA			

Mod. 35\_REV01

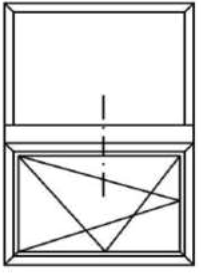
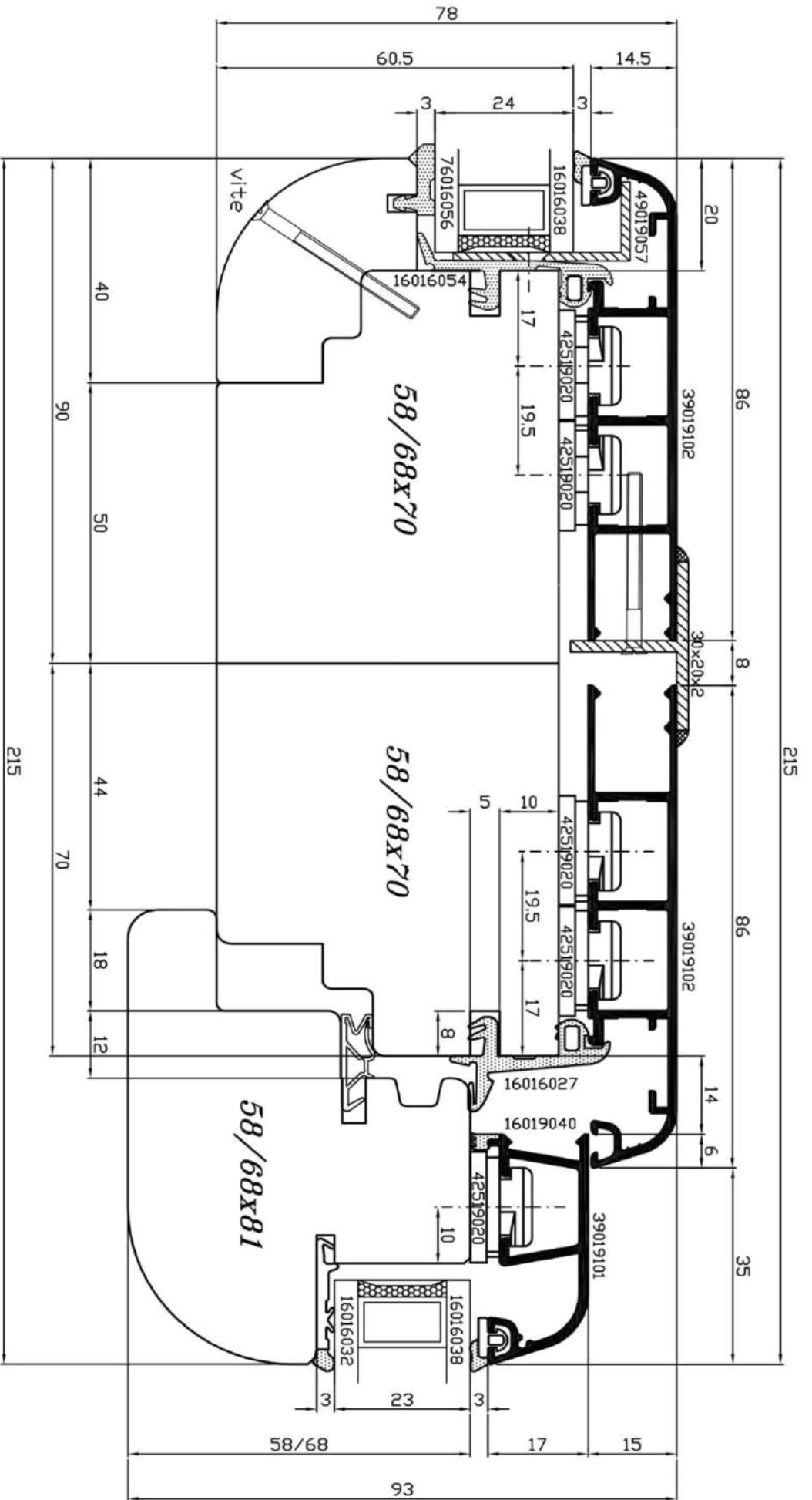

F2A\_tq

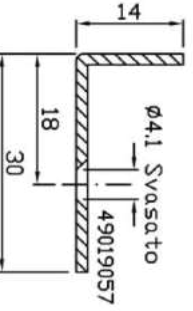

Cliente Standard



REV. 04

Sistema **ASTRO 9**

09S

Scala Disegno

1:1

Tolleranze Generali  $\pm 0,5$  mm

PAGINA

Descrizione: **SEZIONE ORIZZONTALE MONTANTE  
FINESTRA APRIBILE-FISSO**

Mod. 35\_RR01



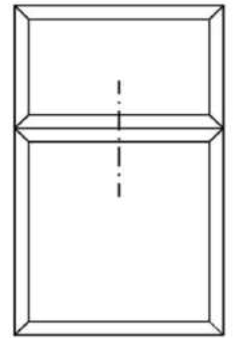

FF\_sof

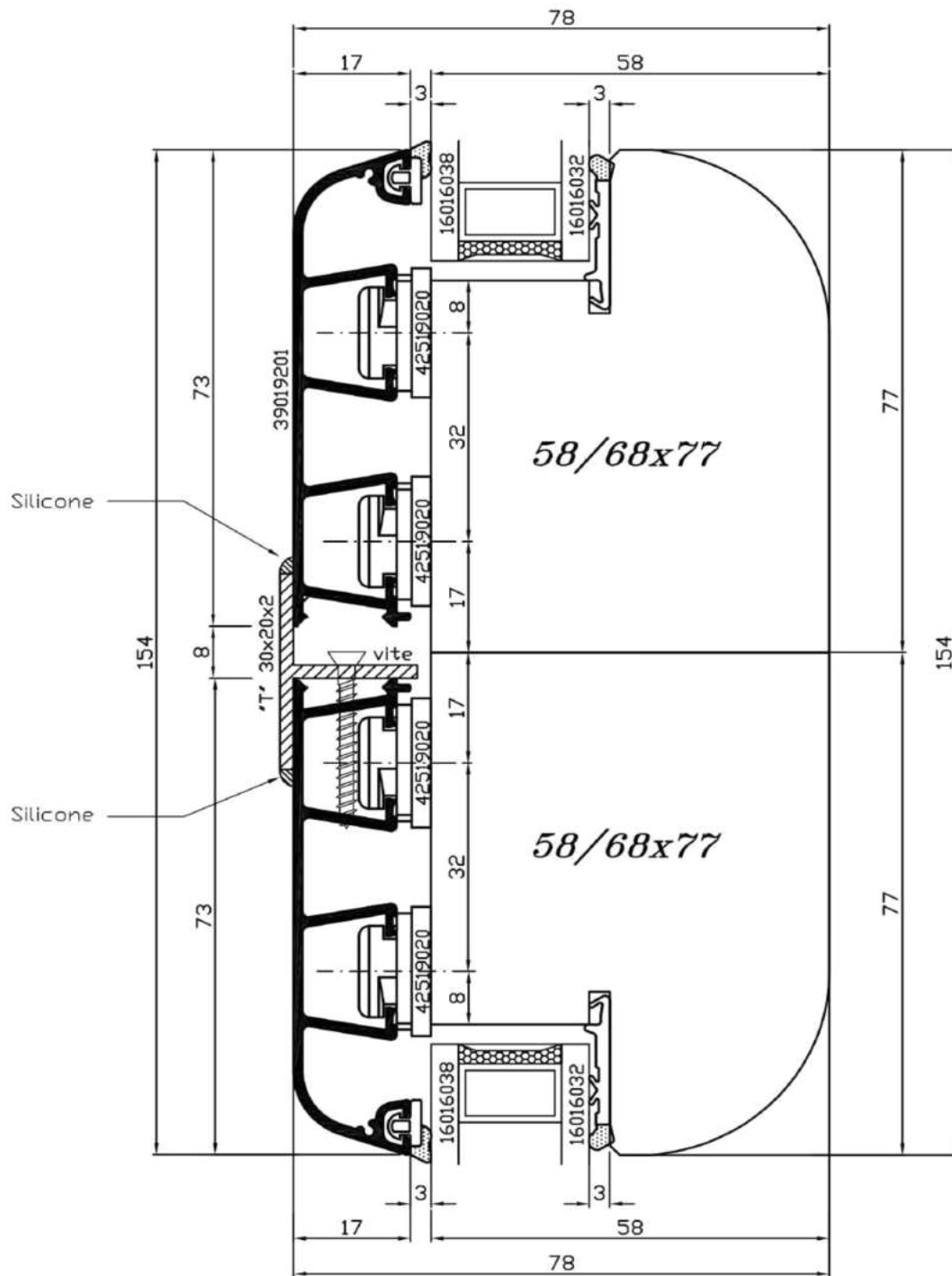

			Sistema <b>ASTRO 9</b>	09S
	Cliente Standard		REV. 00	Scala Disegno
Descrizione: <b>SEZIONE VERTICALE TRAVERSO CENTRALE</b>			Tolleranze Generali	± 0,5 mm
Mod_35_REV01			PAGINA	

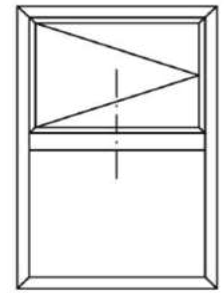
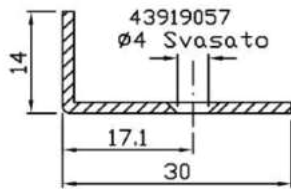

F1A\_soa

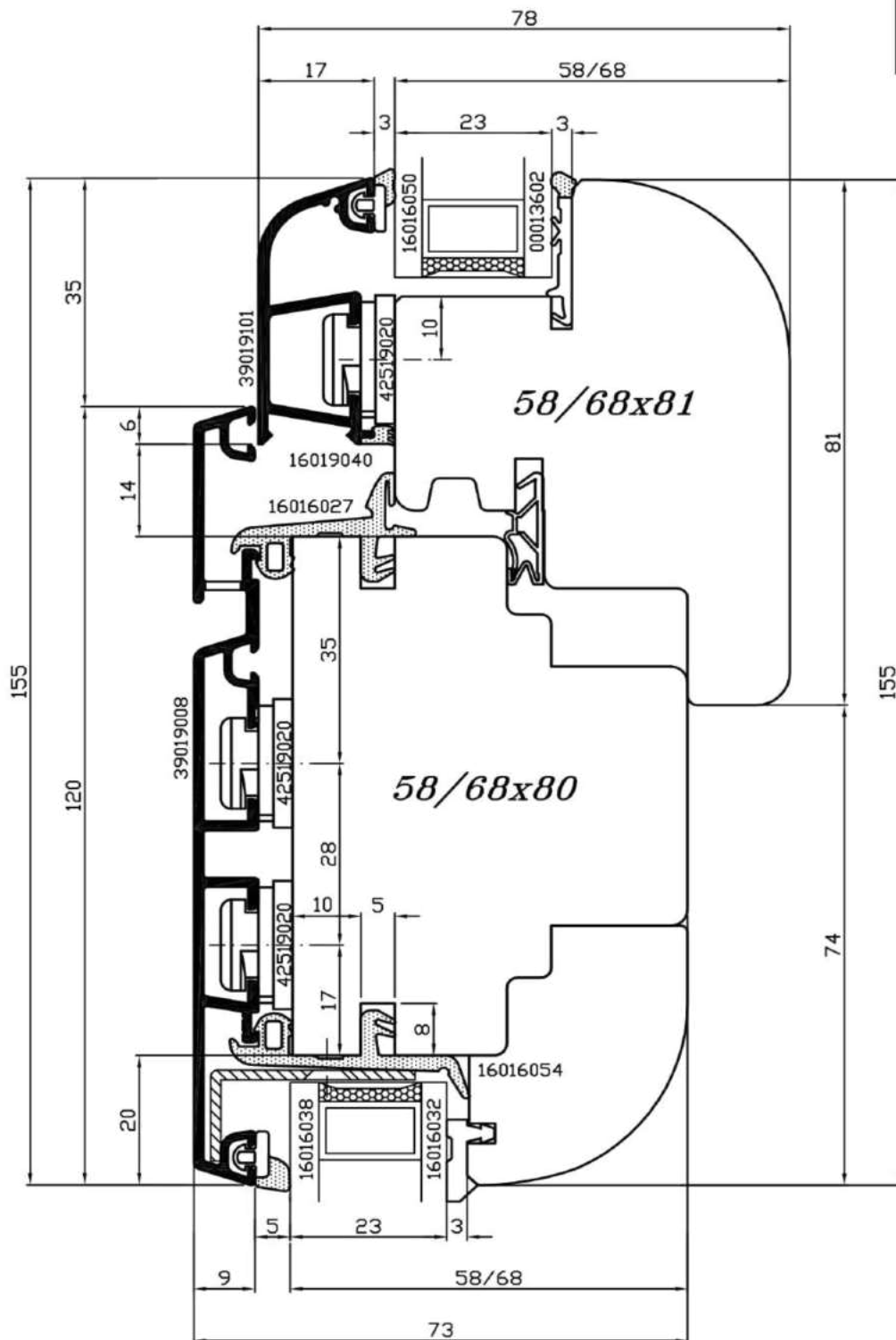

			Sistema <b>ASTRO 9</b>	09S
Cliente Standard			REV. 00	Scala Disegno
Descrizione: <b>SEZIONE VERTICALE TRAVERSO FISSO-APRIBILE</b>			Tolleranze Generali	± 0,5 mm
			PAGINA	

Mod\_35\_REV01

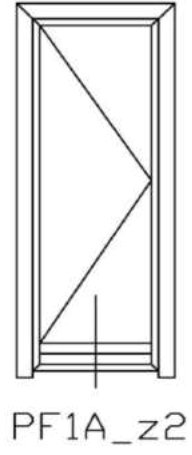
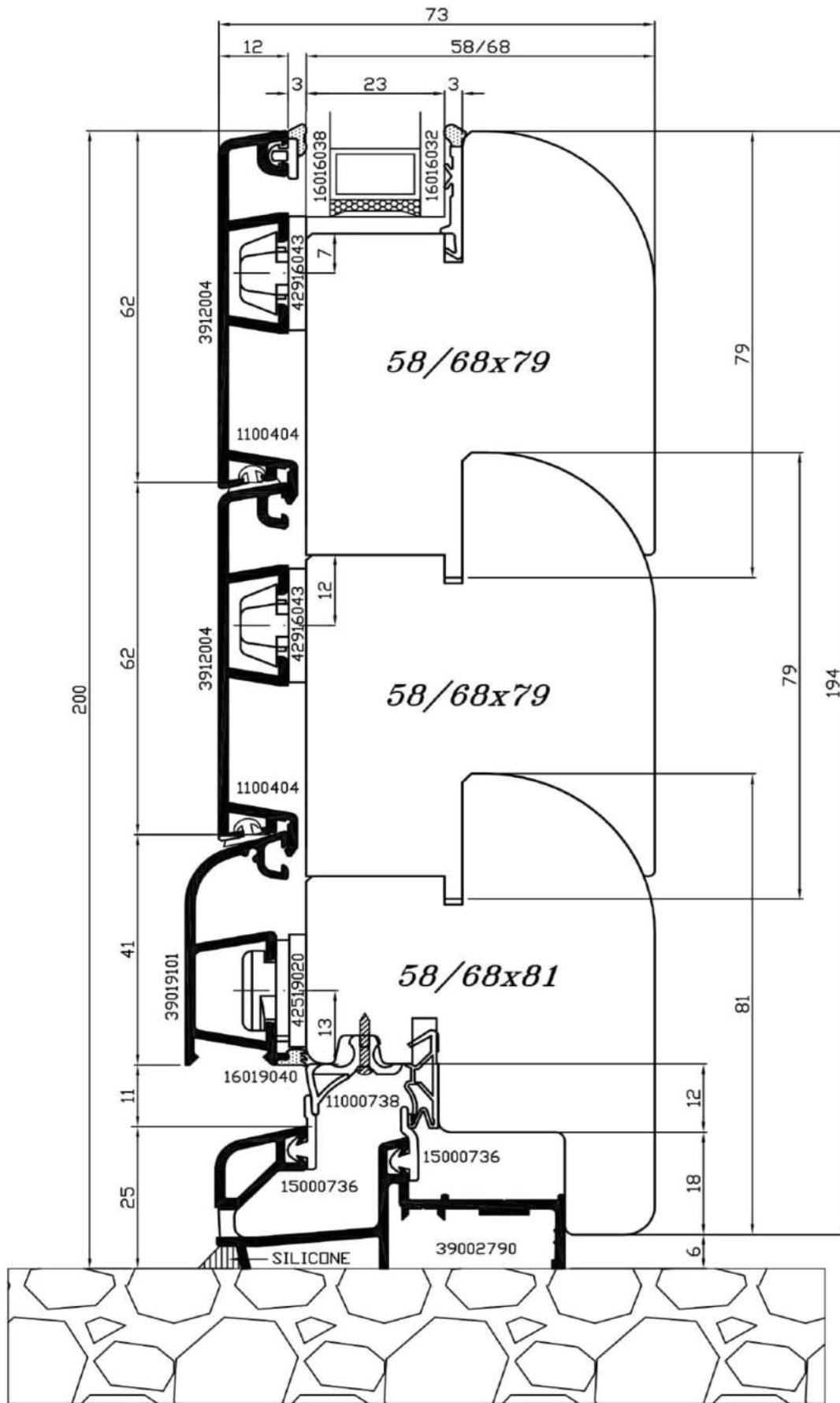

			Sistema <b>ASTRO 9</b>	09S
Cliente Standard	REV. 04		Scala Disegno	Fuori Scala
Descrizione: <b>SEZIONE VERTICALE TRAVERSO INFERIORE PORTAFINESTRA</b>			Tolleranze Generali	± 0,5 mm
			PAGINA	

Mod\_35\_REV01

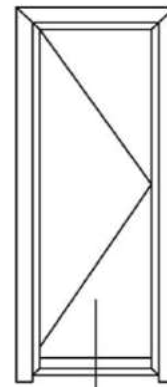

PF1A\_z1

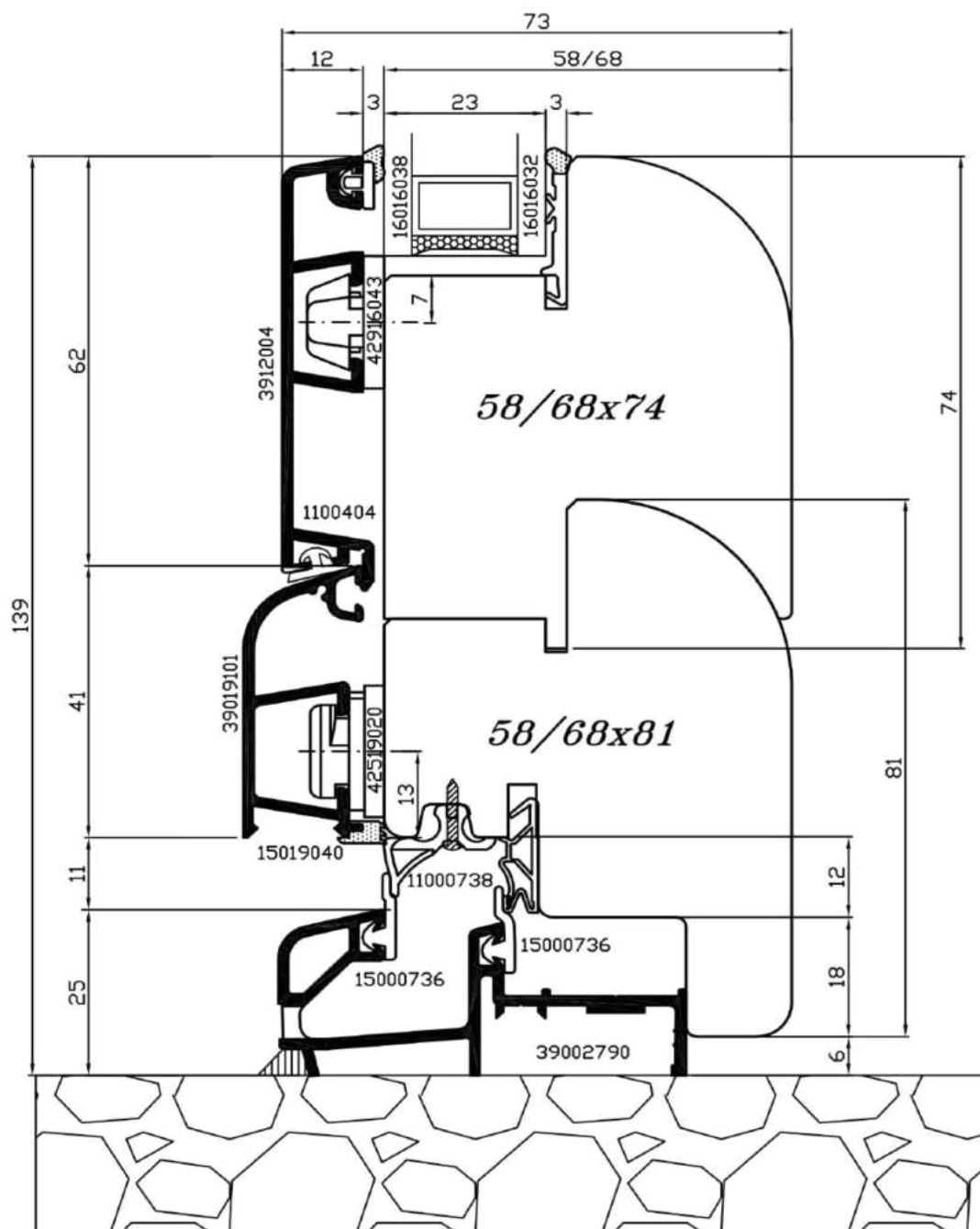

			Sistema <b>ASTRO 9</b>	06S
	Cliente Standard		REV. 04	Scala Disegno
Descrizione: <b>SEZIONE VERTICALE TRAVERSO INFERIORE PORTAFINESTRA</b>			Tolleranze Generali	± 0,5 mm
Mod_35_REV01			PAGINA	

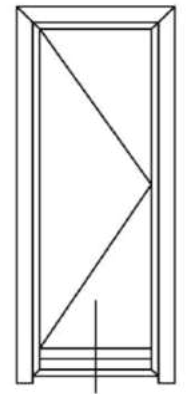
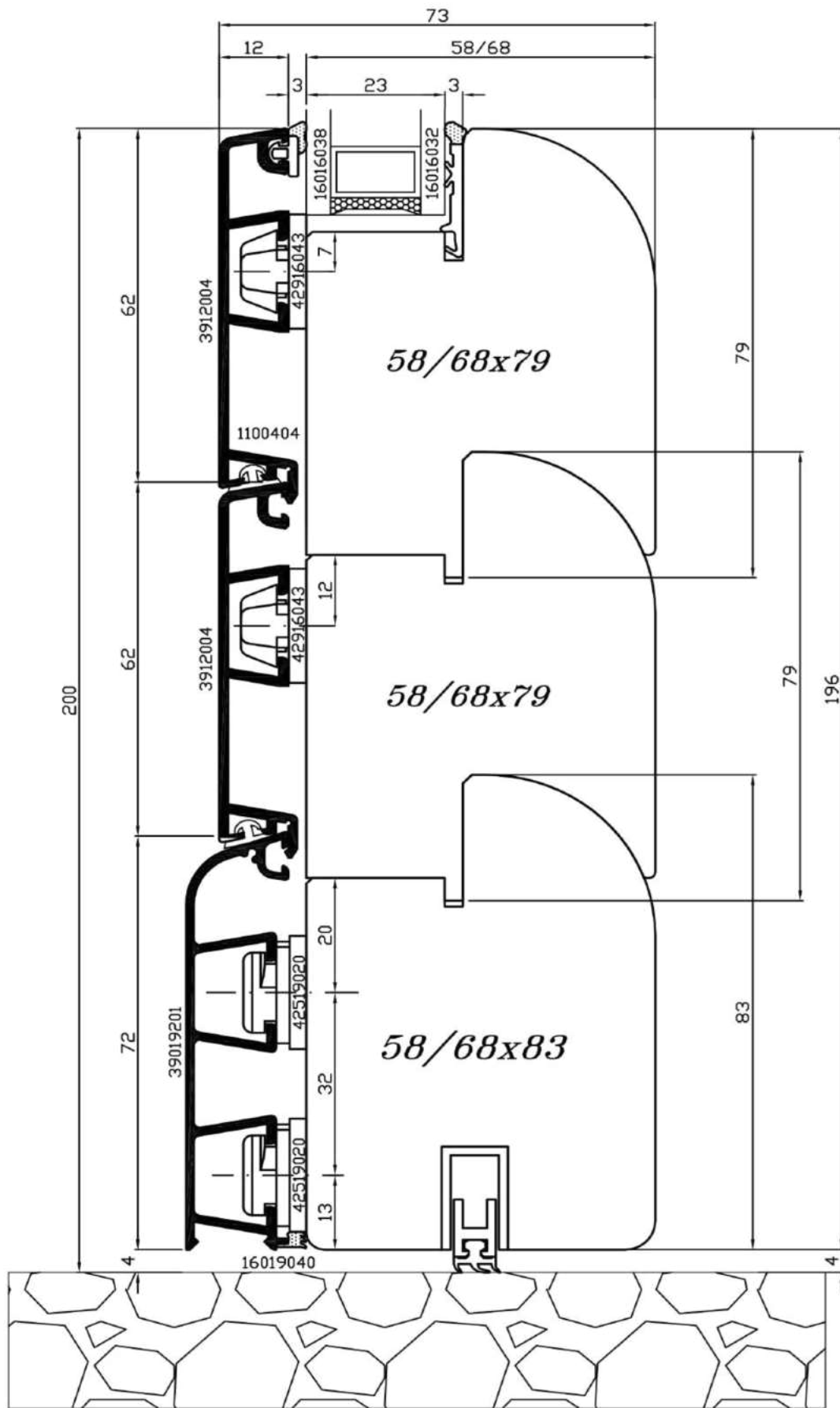

PF1A\_z2

	Cliente Standard		REV. 00	Sistema <b>ASTRO 9</b> 09S
Descrizione: <b>SEZIONE VERTICALE TRAVERSO INFERIORE PORTAFINESTRA</b>				Scala Disegno 1:1
Mod_35_REV01				Tolleranze Generali ± 0,5 mm
				PAGINA

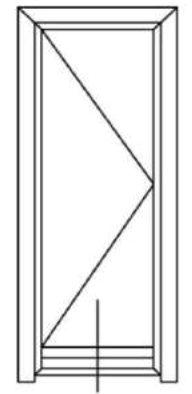
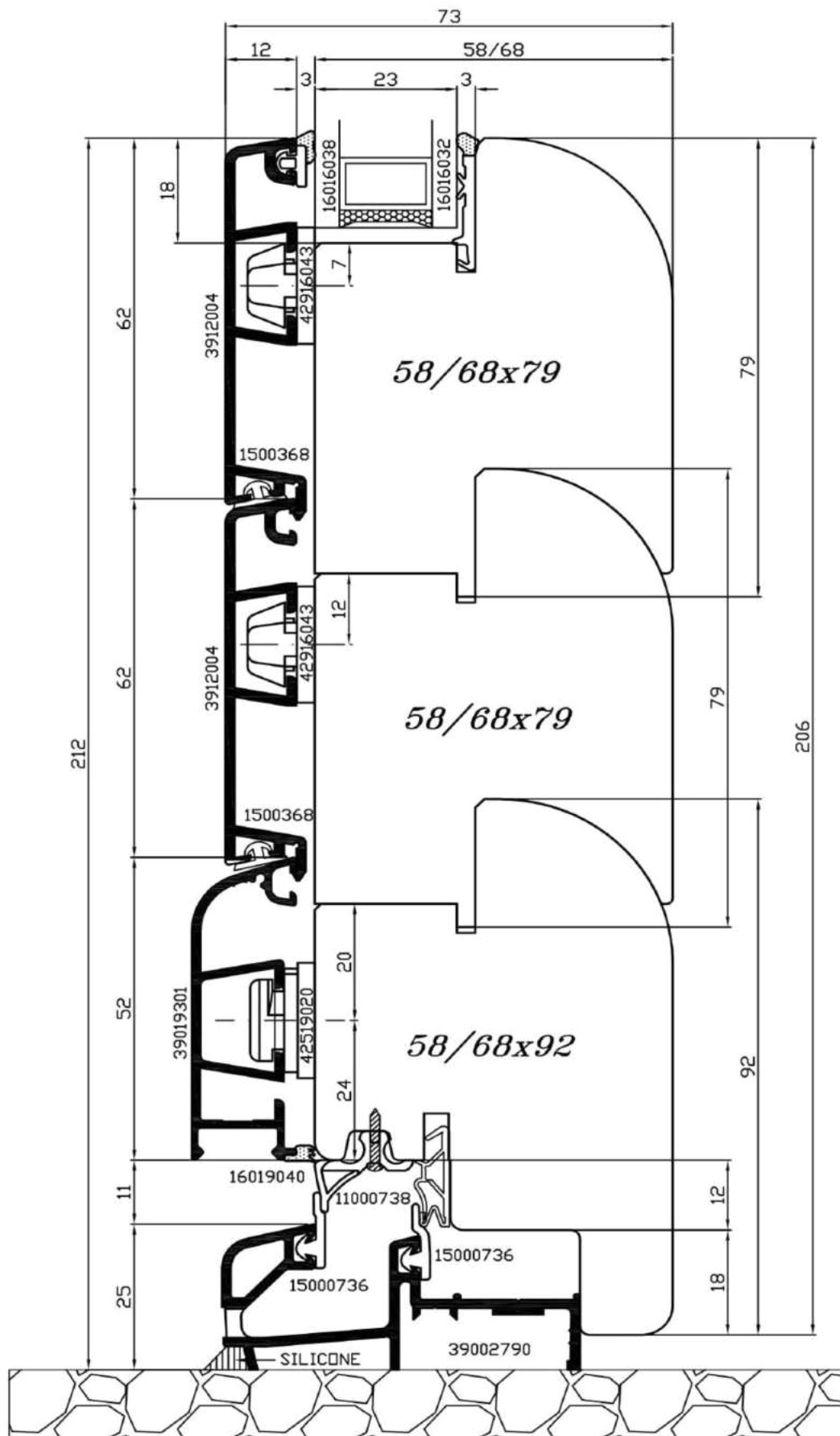

PF1A\_z2

			Sistema <b>ASTRO 9</b> 09S	
Cliente Standard			REV. 00	Scala Disegno Fuori Scala
Descrizione: <b>SEZIONE VERTICALE TRAVERSO INFERIORE PORTAFINESTRA</b>			Tolleranze Generali ± 0,5 mm	
			PAGINA	
Mod_35_REV01				



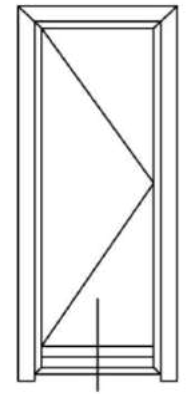
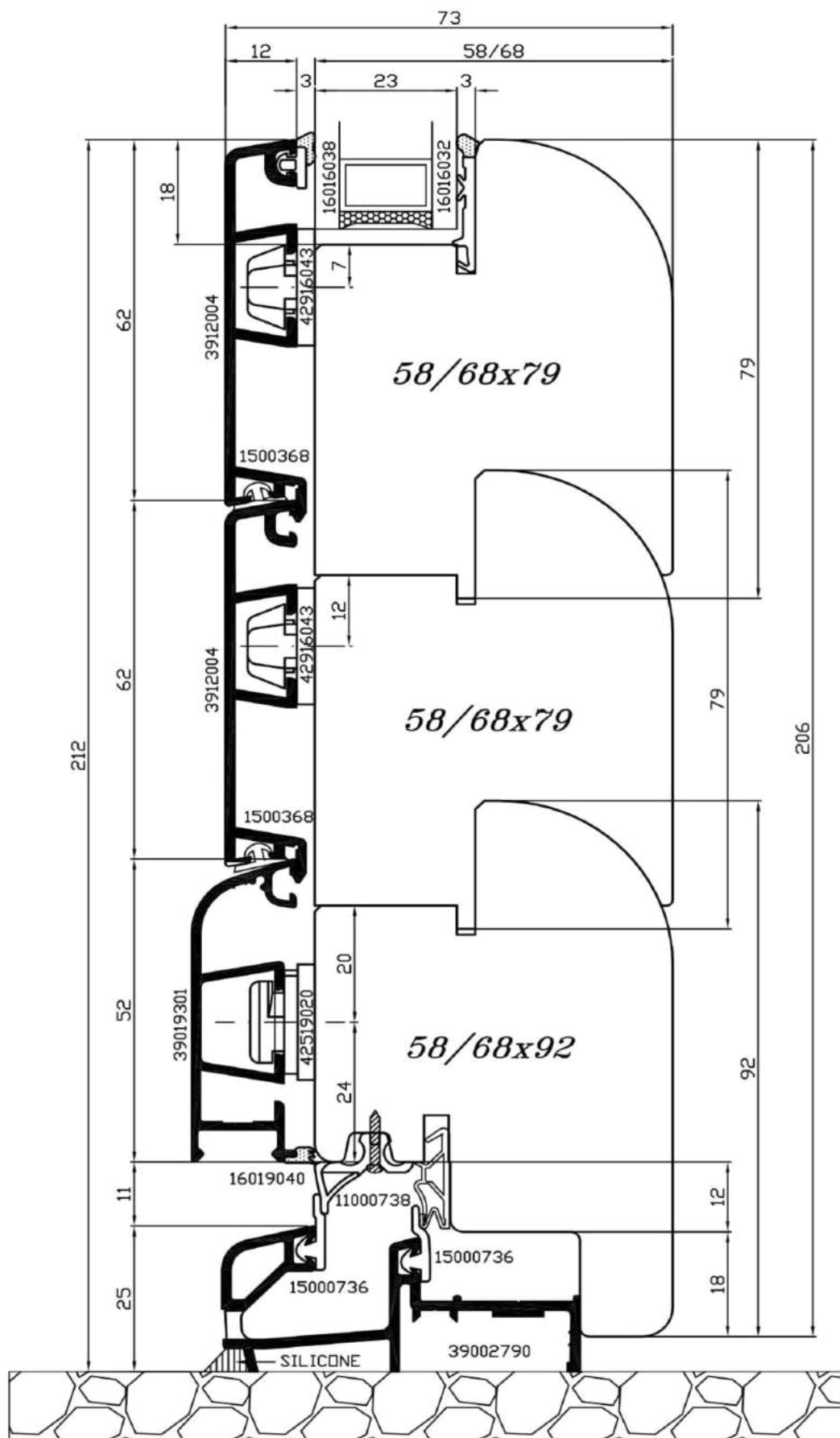

PF1A\_z2

<p>Descrizione:</p>	<p>Cliente Standard</p>		<p>REV. 00</p>	<p>Sistema <b>ASTRO 9</b> 09S</p>
<p><b>SEZIONE VERTICALE TRAVERSO INFERIORE PORTAFINESTRA</b></p>				<p>Scala Disegno Fuori Scala</p>
<p>Mod_35_REV01</p>				<p>Tolleranze Generali ± 0,5 mm</p> <p>PAGINA</p>



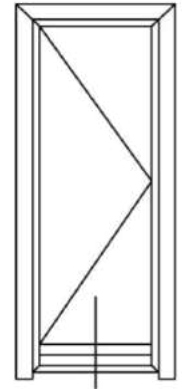
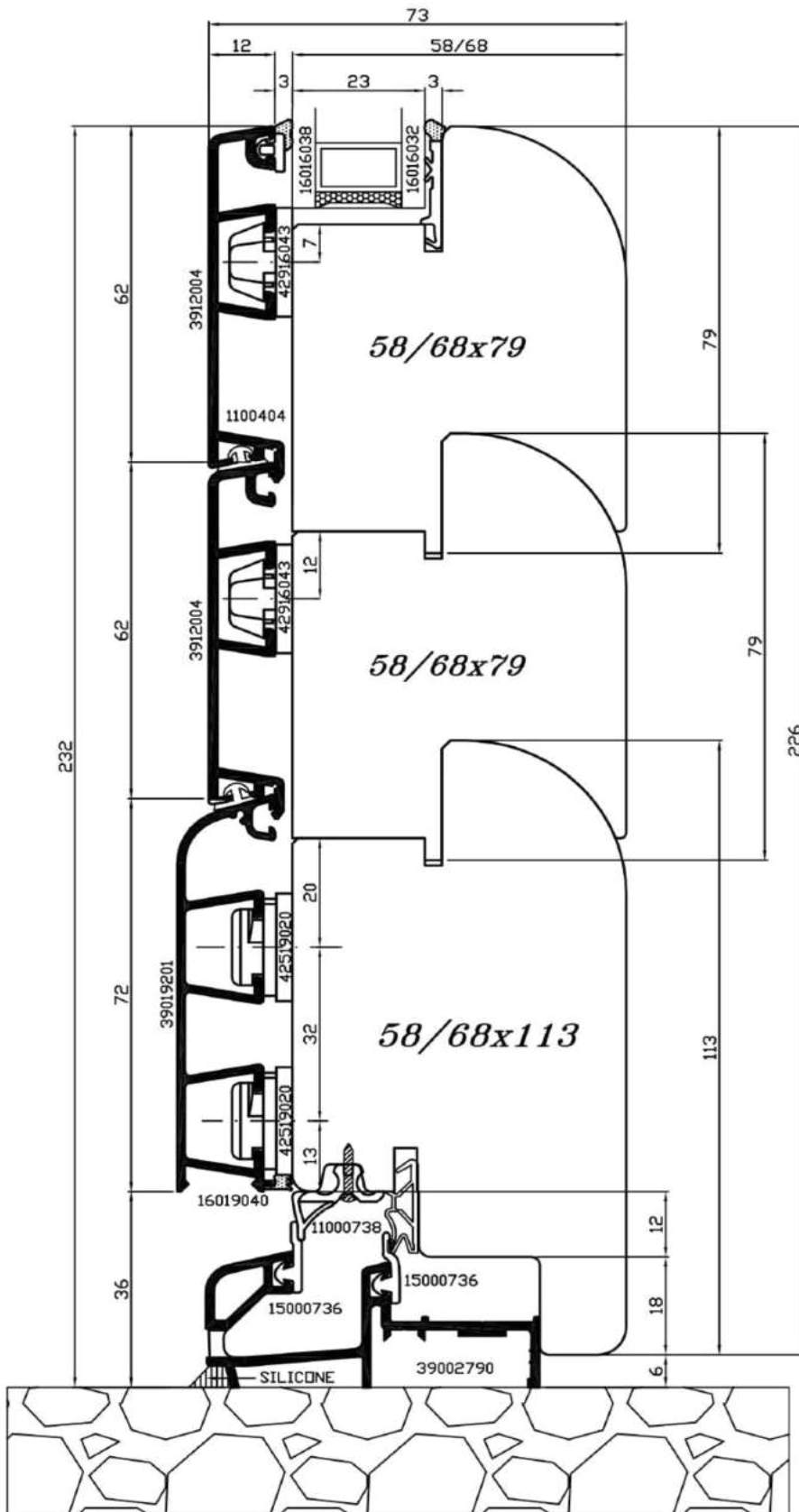

PF1A\_z2

	Cliente Standard		REV. 04	Sistema <b>ASTRO 9</b> 09S
Descrizione: <b>SEZIONE VERTICALE TRAVERSO INFERIORE PORTAFINESTRA</b>				Scala Disegno Fuori Scala
Mod_35_REV01				Tolleranze Generali ± 0,5 mm <b>PAGINA</b>

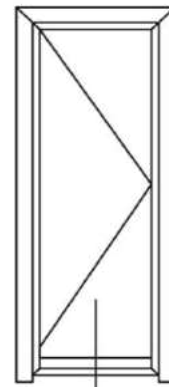
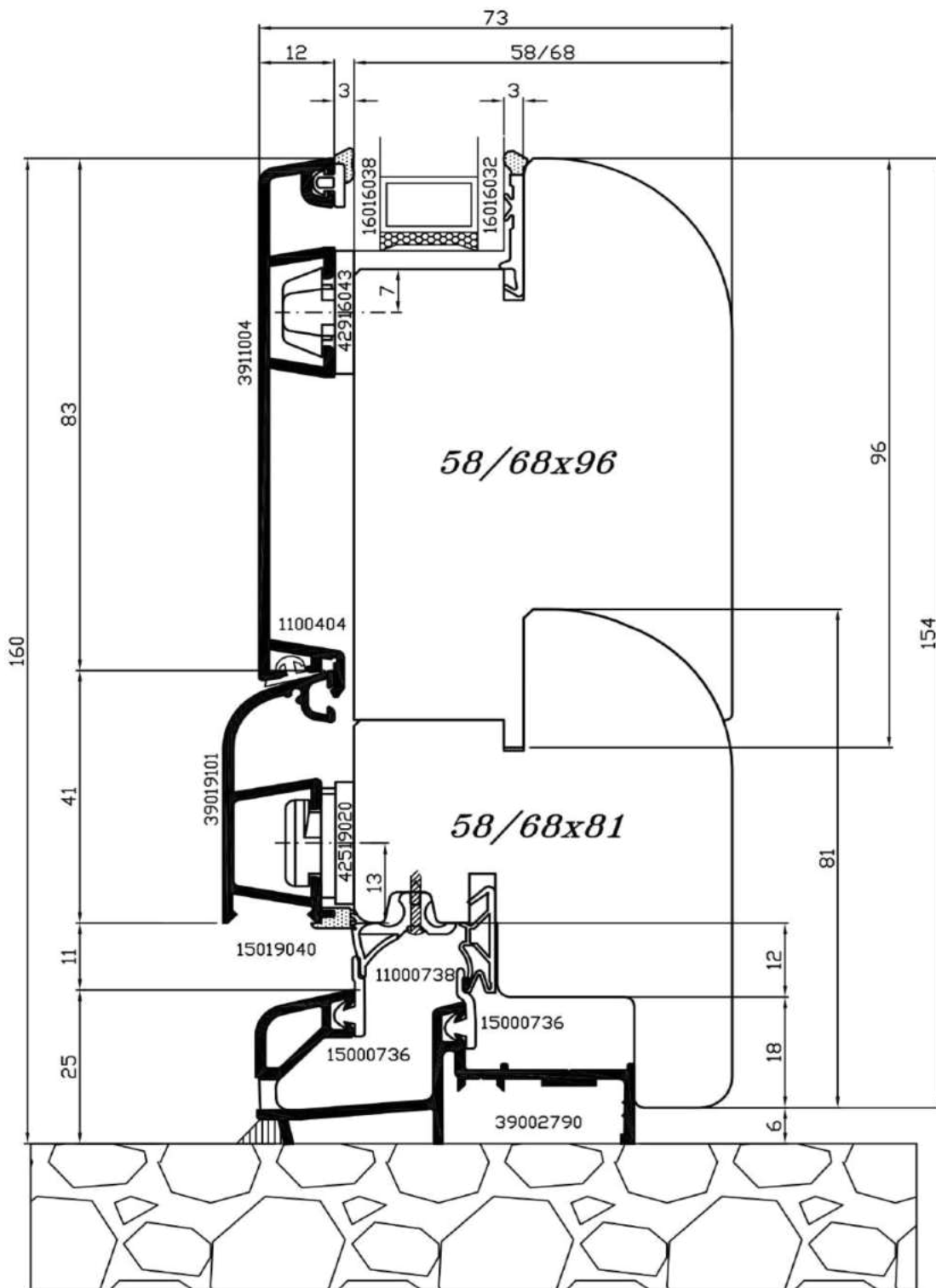

PF1A\_z1

<p>Descrizione:</p>	<p>Cliente Standard</p>		<p>Sistema <b>ASTRO 9</b></p>	<p>06S</p>
<p><b>SEZIONE VERTICALE TRAVERSO INFERIORE PORTAFINESTRA</b></p>			<p>Scala Disegno</p>	<p>1:1</p>
			<p>Tolleranze Generali</p>	<p>± 0,5 mm</p>

Mod\_35\_REV01

PAGINA

# PORTAFINESTRA MANIGLIA PASSANTE

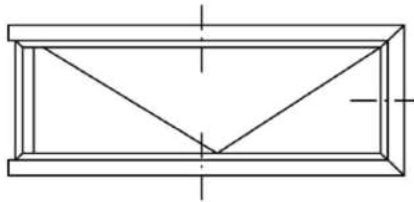
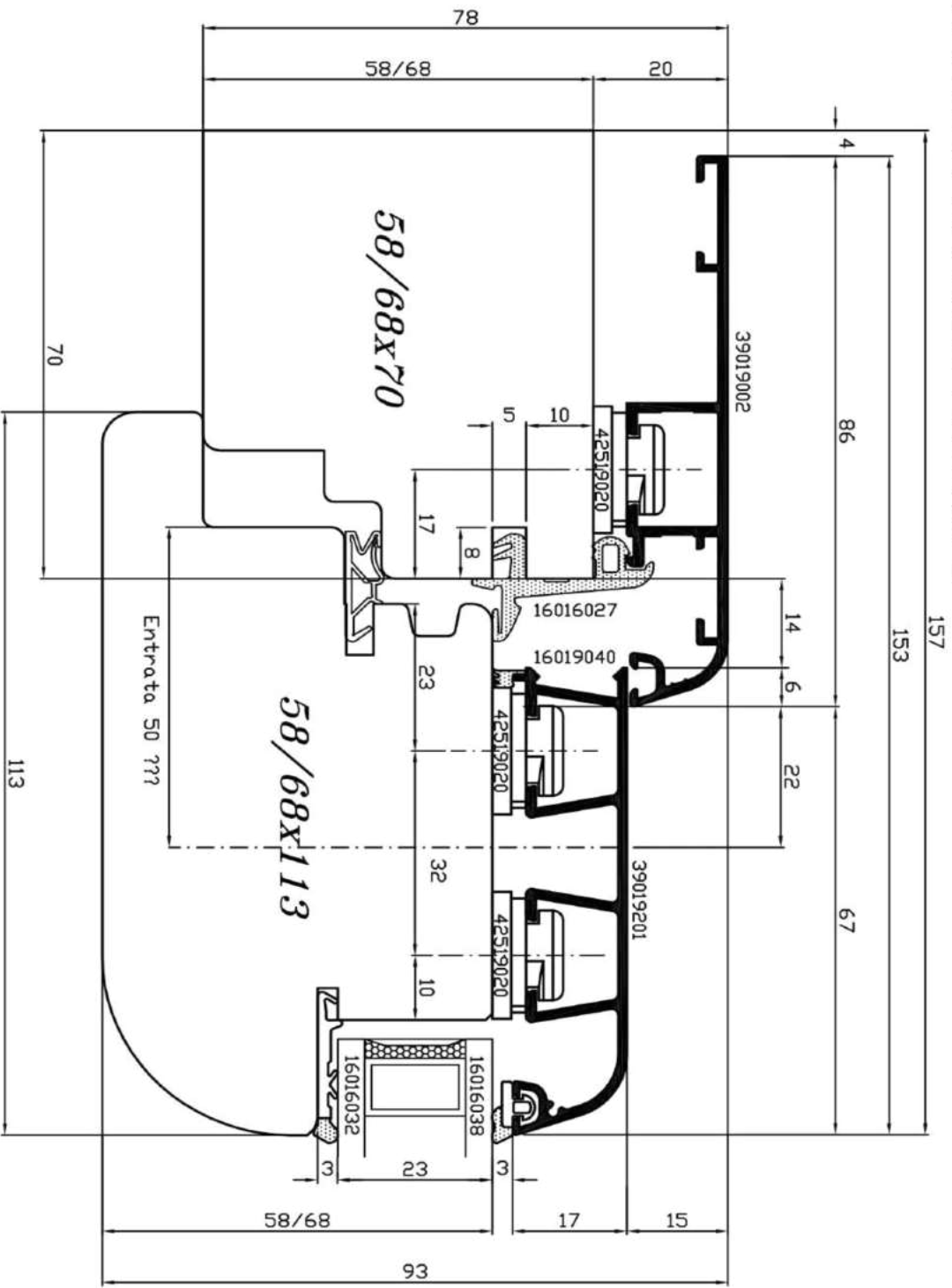

PF1A\_z1

Descrizione: <b>SEZIONE VERTICALE                  E ORIZZONTALE PORTAFINESTRA</b>				Sistema <b>ASTRO 9</b> 09S	
Cliente Standard		REV. 04		Scala Disegno    1:1	
Mod. 35_REV01		Tolleranze Generali    ± 0,5 mm		PAGINA	

# PORTAFINESTRA MANIGLIA PASSANTE

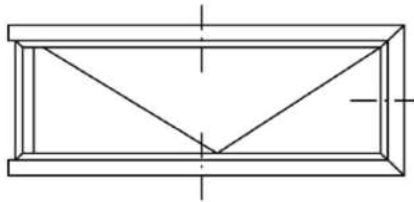
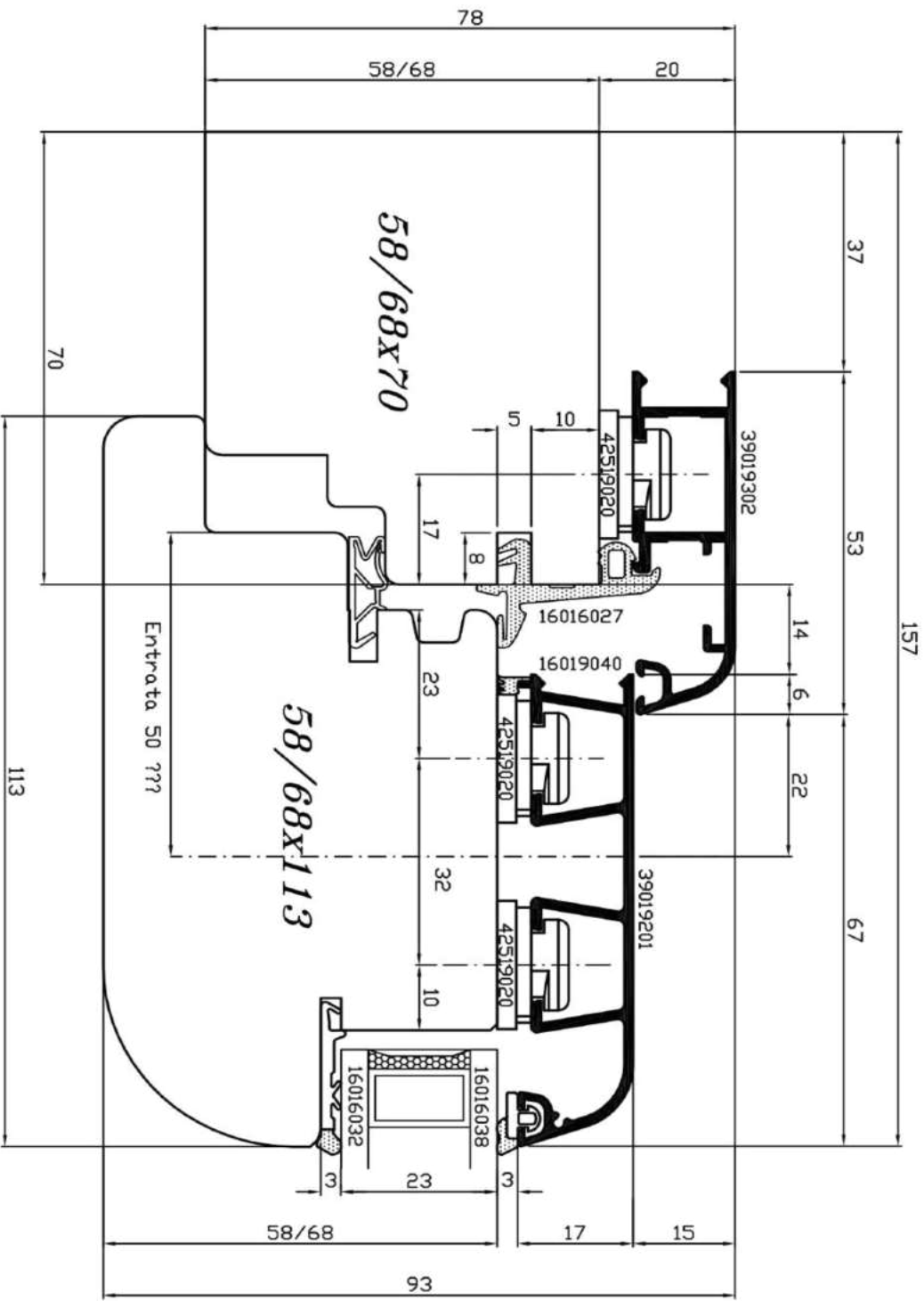

PF1A\_z1

Descrizione:		<b>SEZIONE VERTICALE</b> <b>E ORIZZONTALE PORTAFINESTRA</b>	
Cliente Standard			REV. 00
Sistema <b>ASTRO 9</b>		09S	
Scala Disegno		1:1	
Tolleranze Generali		± 0,5 mm	
PAGINA			

Mod. 35\_REV01



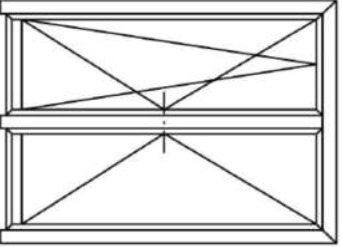
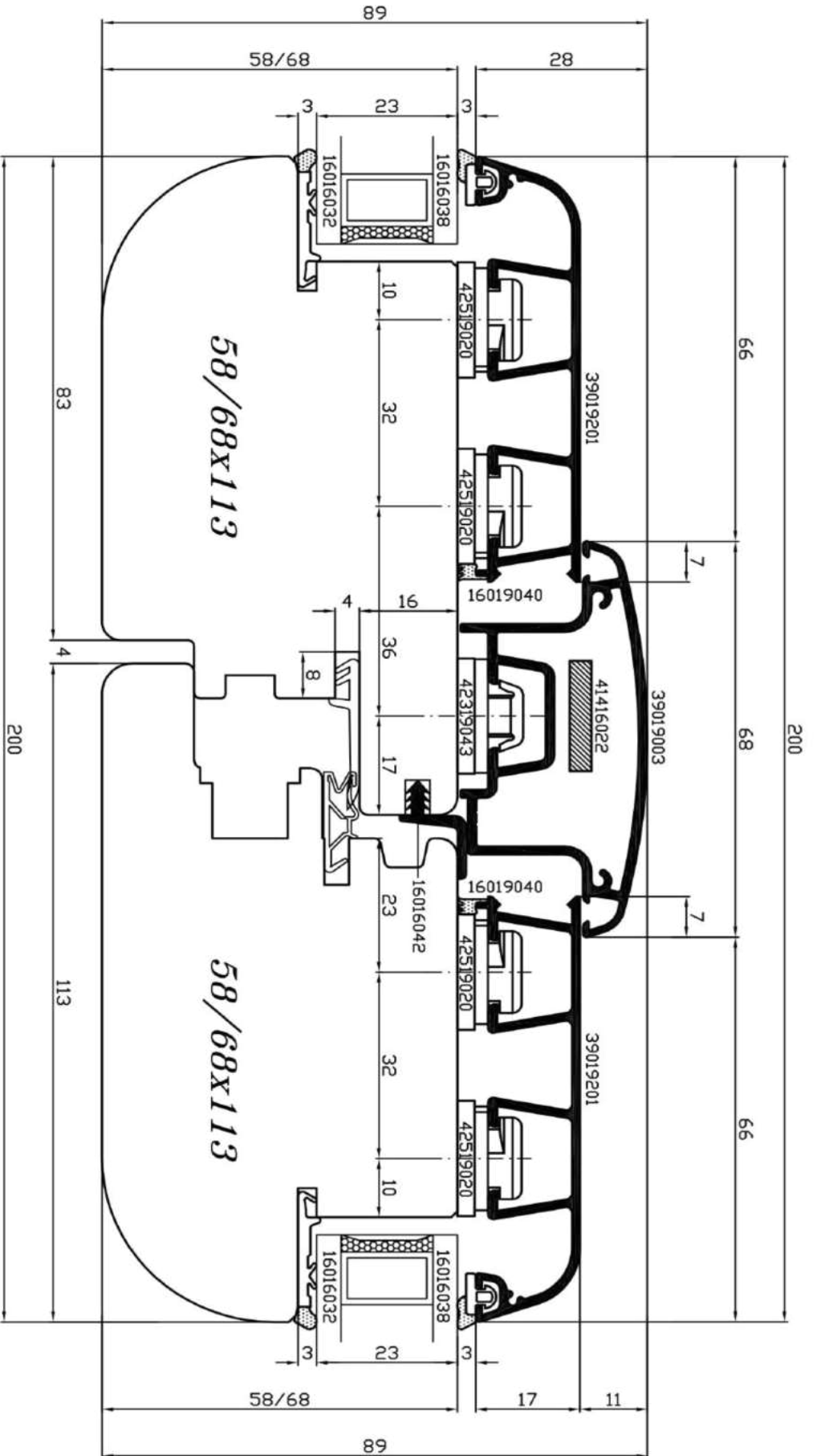



PF2A\_z1

Descrizione:		Sistema <b>ASTRO 9</b>		09S
Cliente Standard		Scala Disegno		1:1
REV. 04		Tolleranze Generali		± 0,5 mm
Mod. 35_REV01		PAGINA		

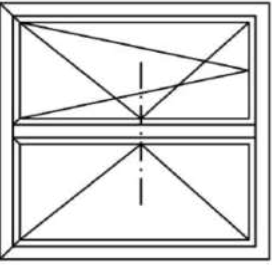
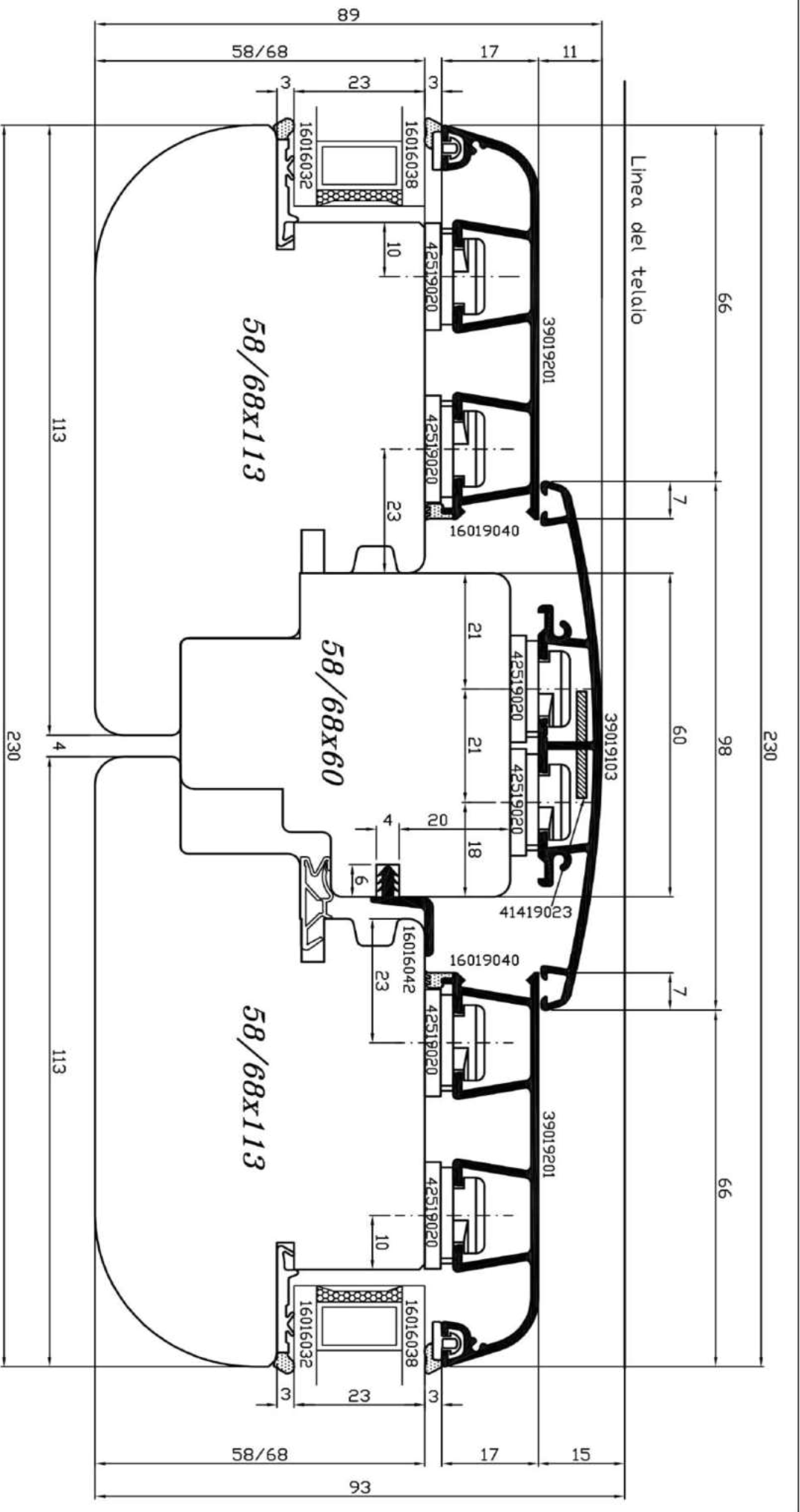
**SEZIONE ORIZZONTALE CENTRALE**



F2A

Descrizione:		<p style="text-align: center;"><b>SEZIONE ORIZZONTALE</b> <b>SNODO CENTRALE ANTA LARGA</b></p>	
Cliente	Standard		
Mod.	35_RR01		
REV.	04	Sistema	<b>ASTRO 9</b>
		Scala Disegno	09S
		Tolleranze Generali	± 0,5 mm
		<b>PAGINA</b>	

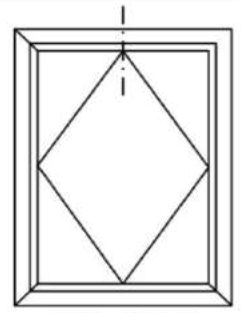

BILICO

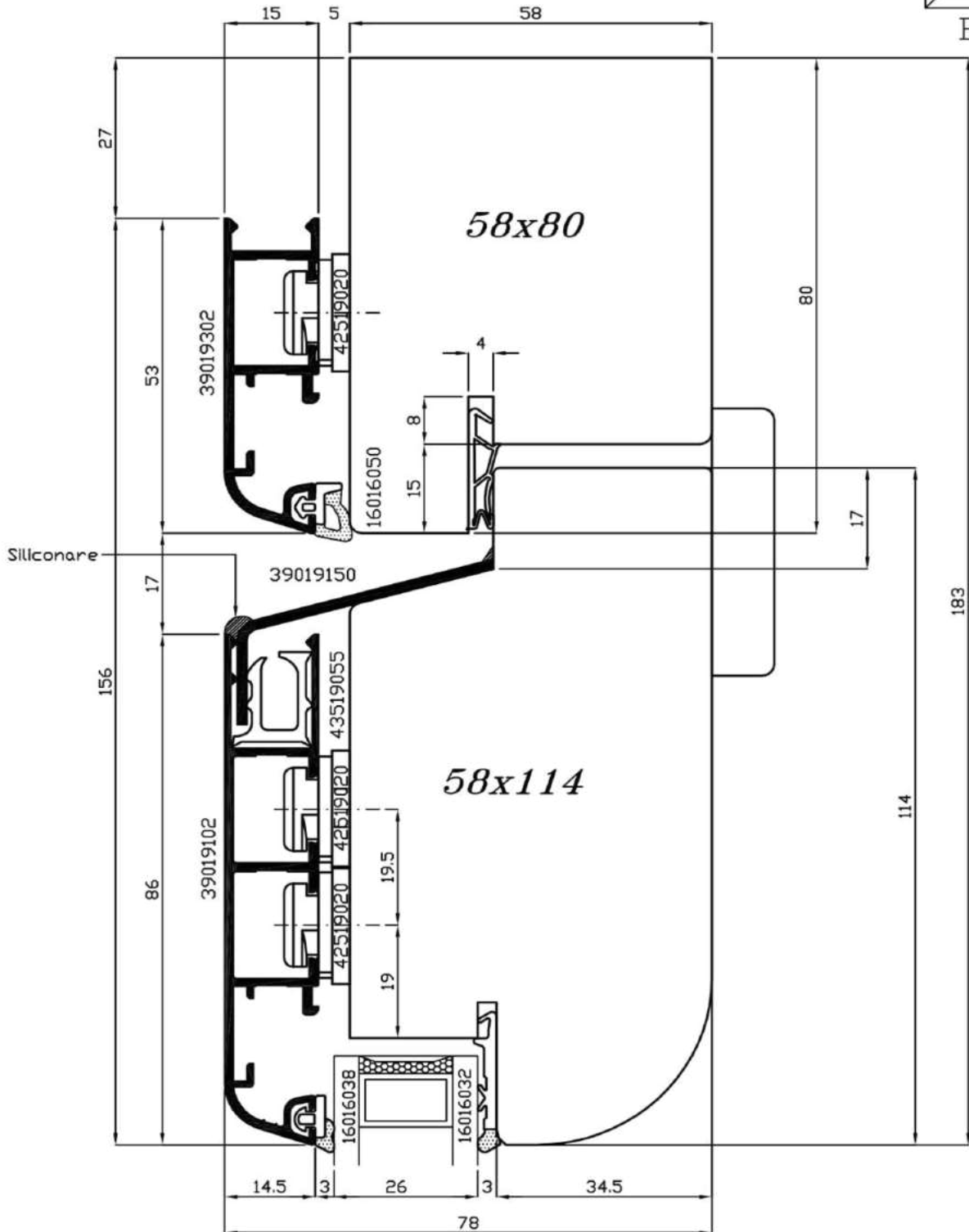

			Sistema Astro 6	09S
Cliente			REV. 01	Scala Disegno 1:1
Descrizione: <b>SEZIONE VERTICALE TRAVERSO SUPERIORE</b>			Tolleranze Generali	+/-0,5mm
			PAGINA	
Mod_35_REV01				

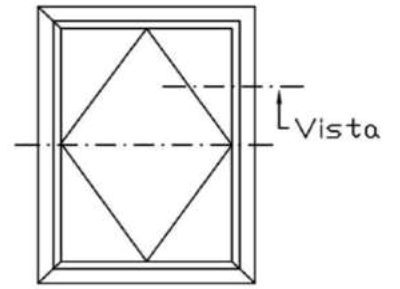

BILICO

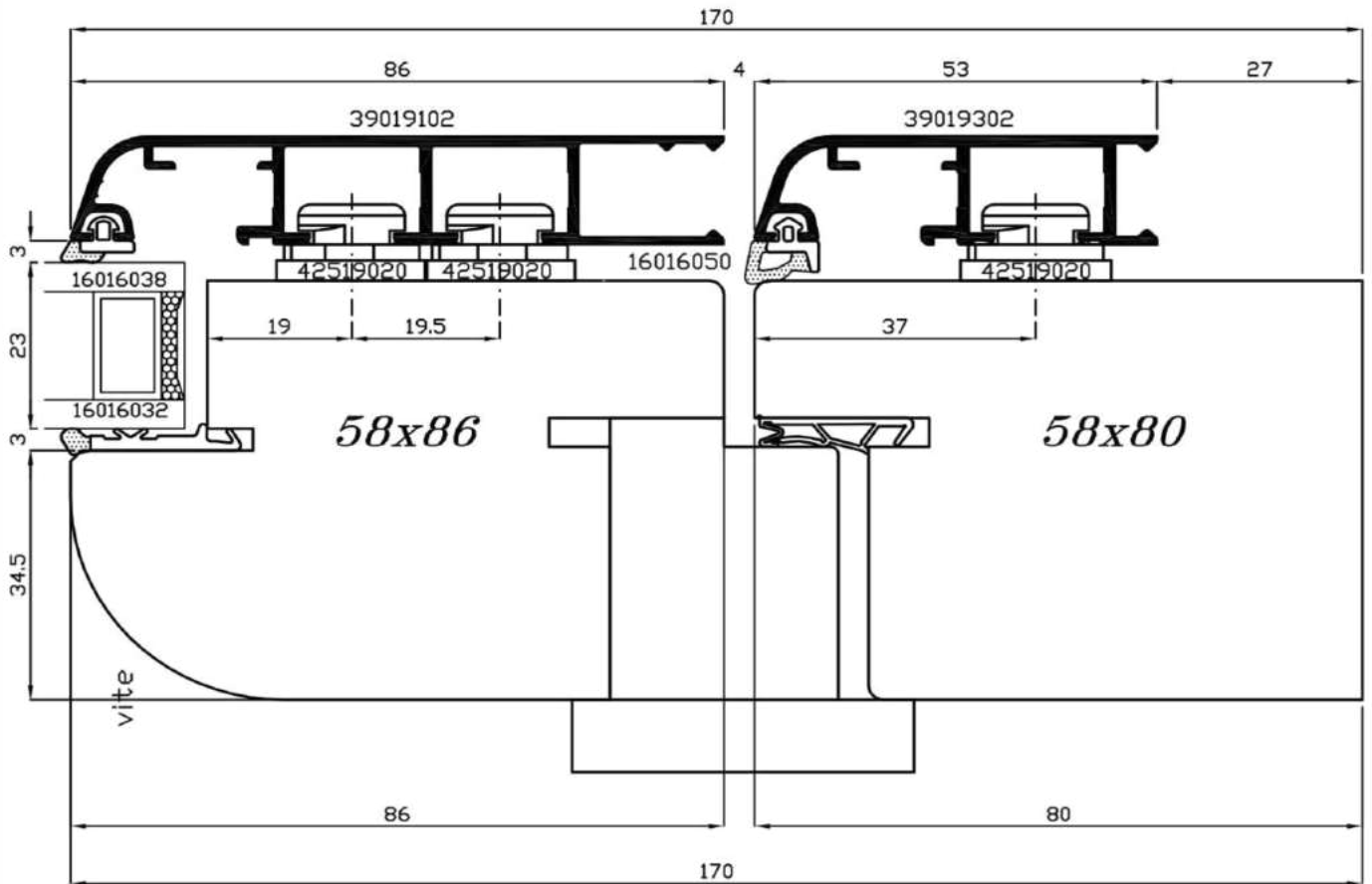

			Sistema Astro 9	09S
	Cliente		REV. 01	Scala Disegno
Descrizione: <b>SEZIONE ORIZZONTALE MONTANTE VISTA SUPERIORE</b>			Tolleranze Generali	+/-0,5mm
			PAGINA	
Mod_35_REV01				

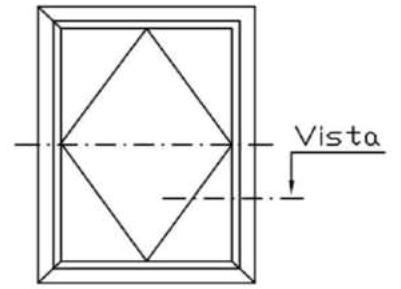

BILICO

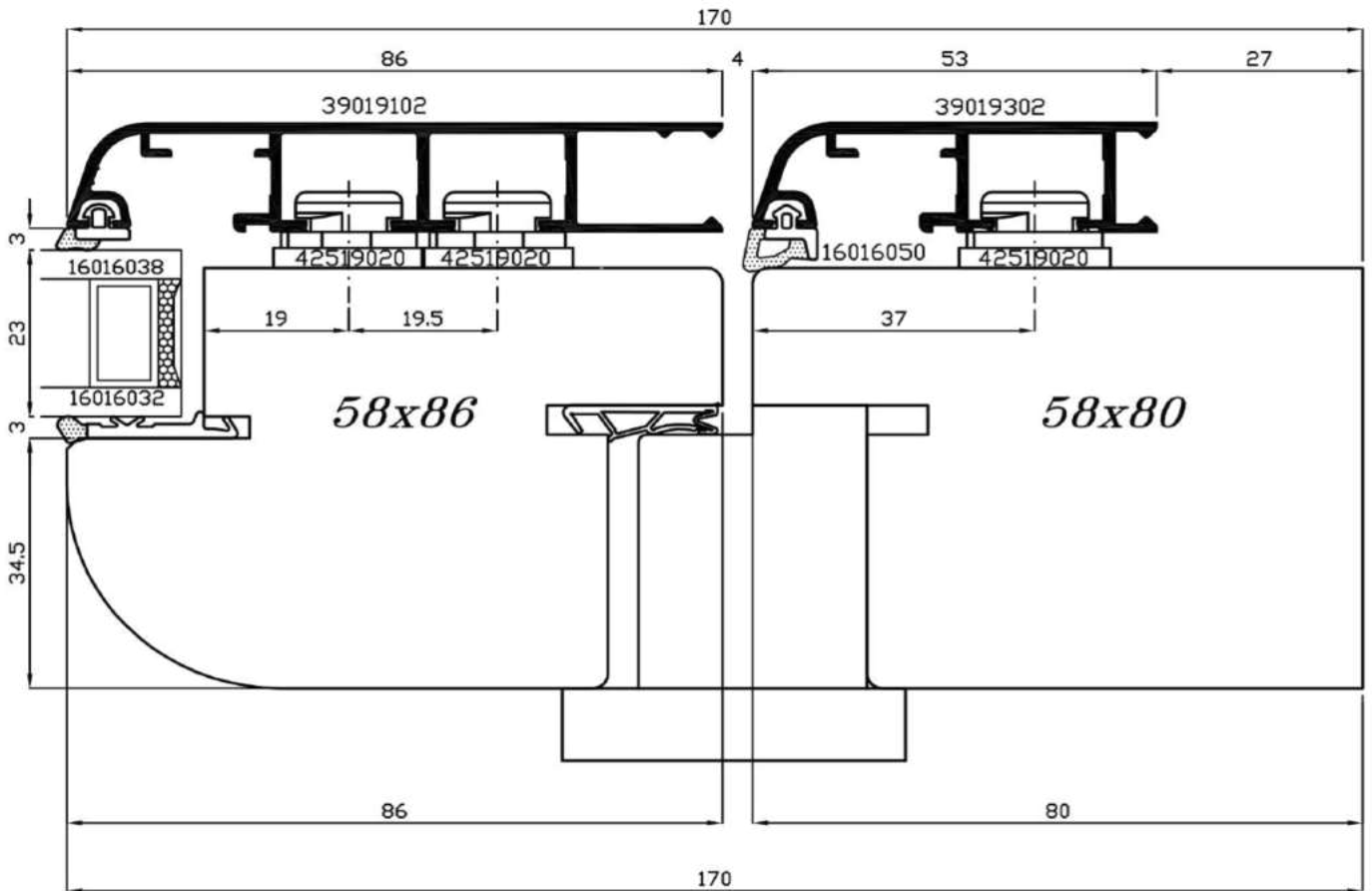

				Sistema Astro 9	09S
	Ciente		REV. 01	Scala Disegno	1:1
Descrizione:	<b>SEZIONE ORIZZONTALE MONTANTE VISTA INFERIORE</b>			Tolleranze Generali	+/-0,5mm
Mod_35_REV01				PAGINA	

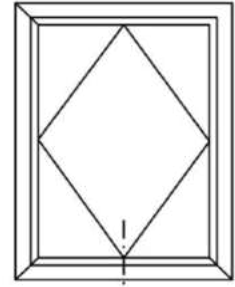

BILICO

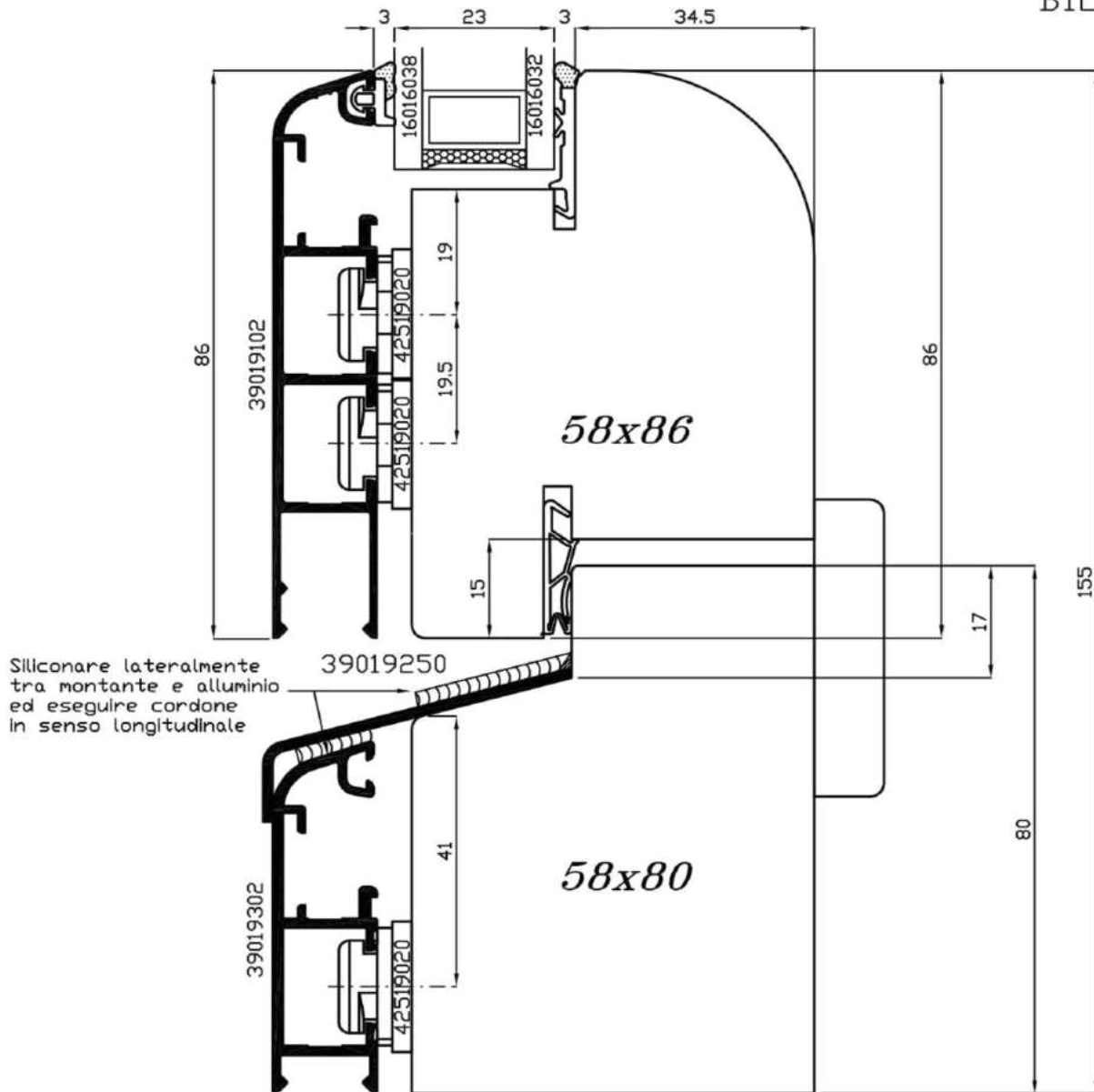

			Sistema Astro 9	09S
	Cliente		REV. 01	Scala Disegno
Descrizione: <b>SEZIONE VERTICALE TRAVERSO INFERIORE</b>			Tolleranze Generali	+/-0,5mm
			PAGINA	

Mod\_35\_REV01



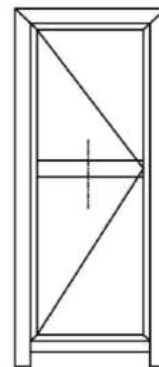

PF1A\_ta

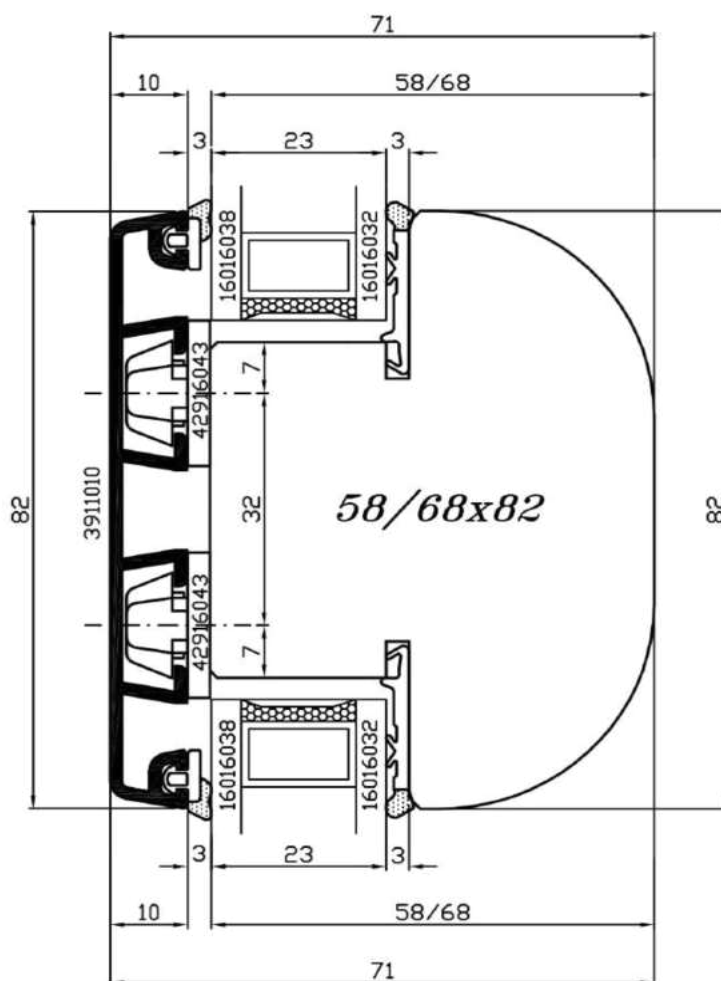
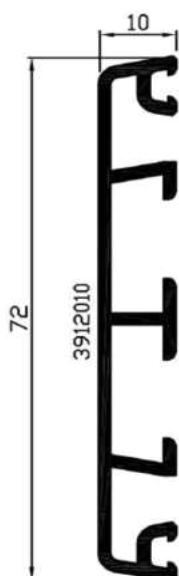
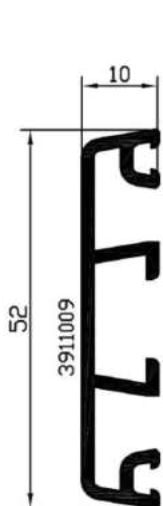

			File:09s326_050217	Sistema <b>ASTRO 9</b>	09S
	Cliente Standard		REV. 04	Scala Disegno	1:1
Descrizione: <b>SEZIONE VERTICALE TRAVERSO CENTRALE PORTAFINESTRA</b>			Tolleranze Generali ± 0,5 mm		
Mod_35_REV01			<b>PAGINA</b>		

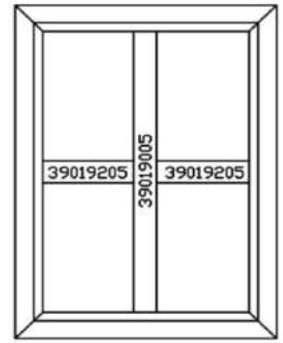
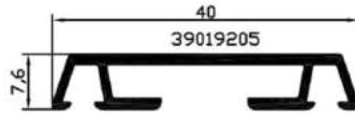
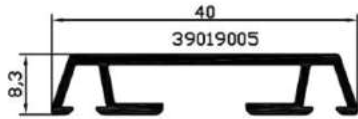

F1A

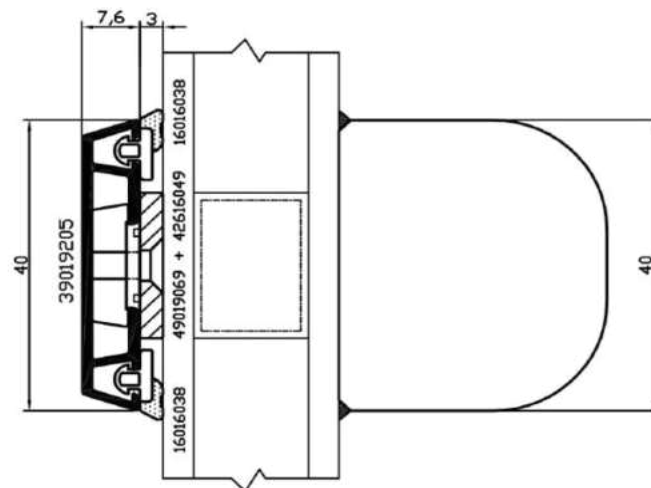
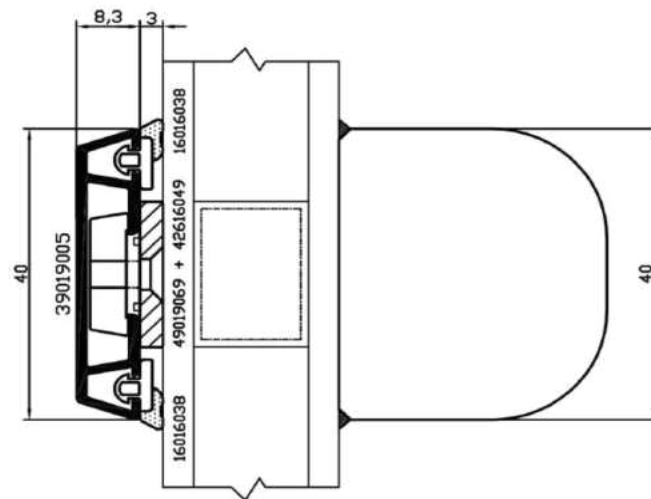

				Sistema <b>ASTRO 9</b>	09S
	Cliente Standard		REV. 00	Scala Disegno	1:1
Descrizione: <b>SEZIONE VERTICALE INGLESINA</b>			Tolleranze Generali		± 0,5 mm
			PAGINA		
Mod_35_REV01					

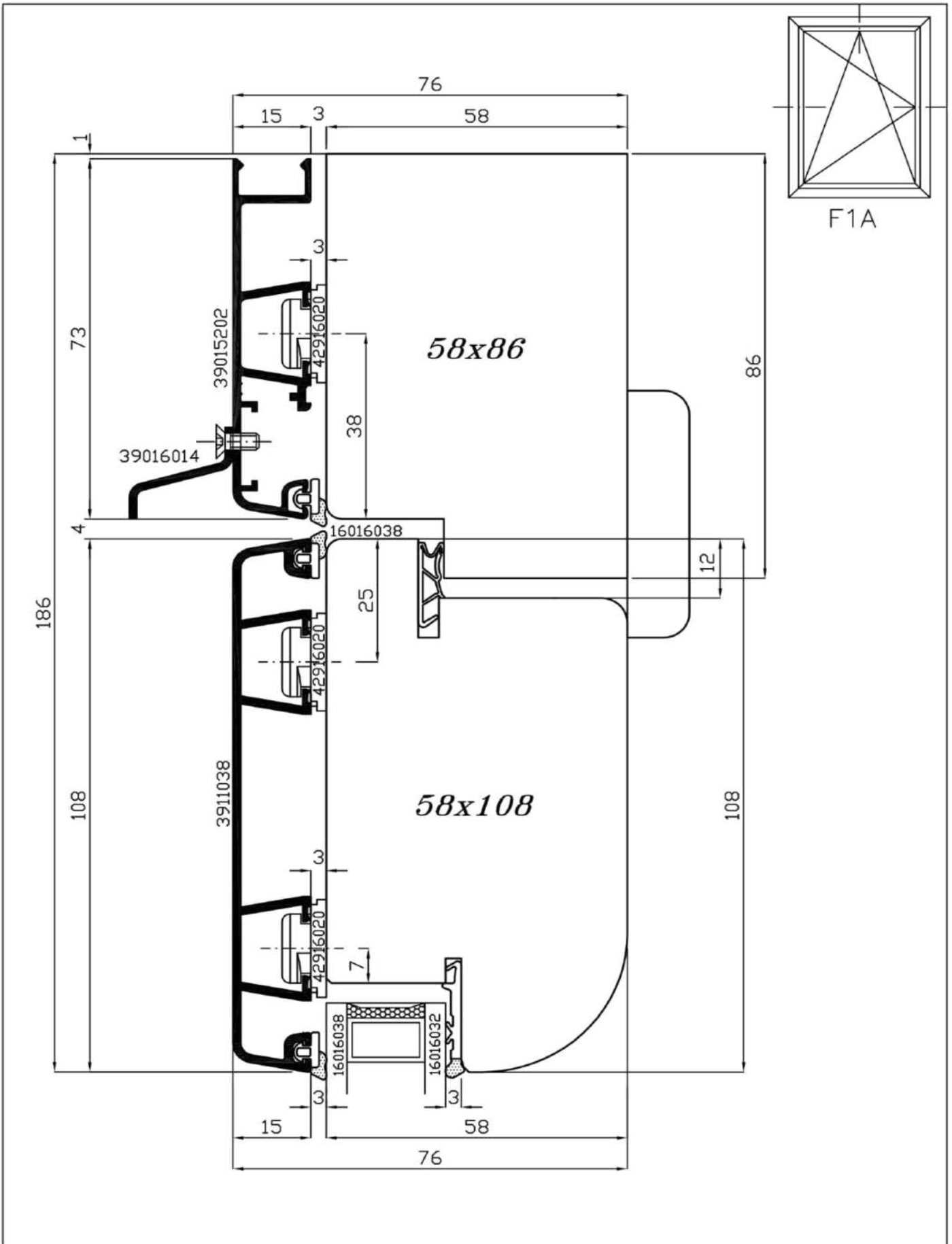

				Sistema <b>ASTRO 9</b> 09S
	Cliente Standard		REV. 00	Scala Disegno 1:1
Descrizione: <b>SEZIONE VERTICALE E ORIZZONTALE</b>				Tolleranze Generali ± 0,5 mm
Mod_35_REV01				PAGINA

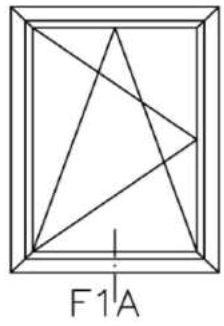
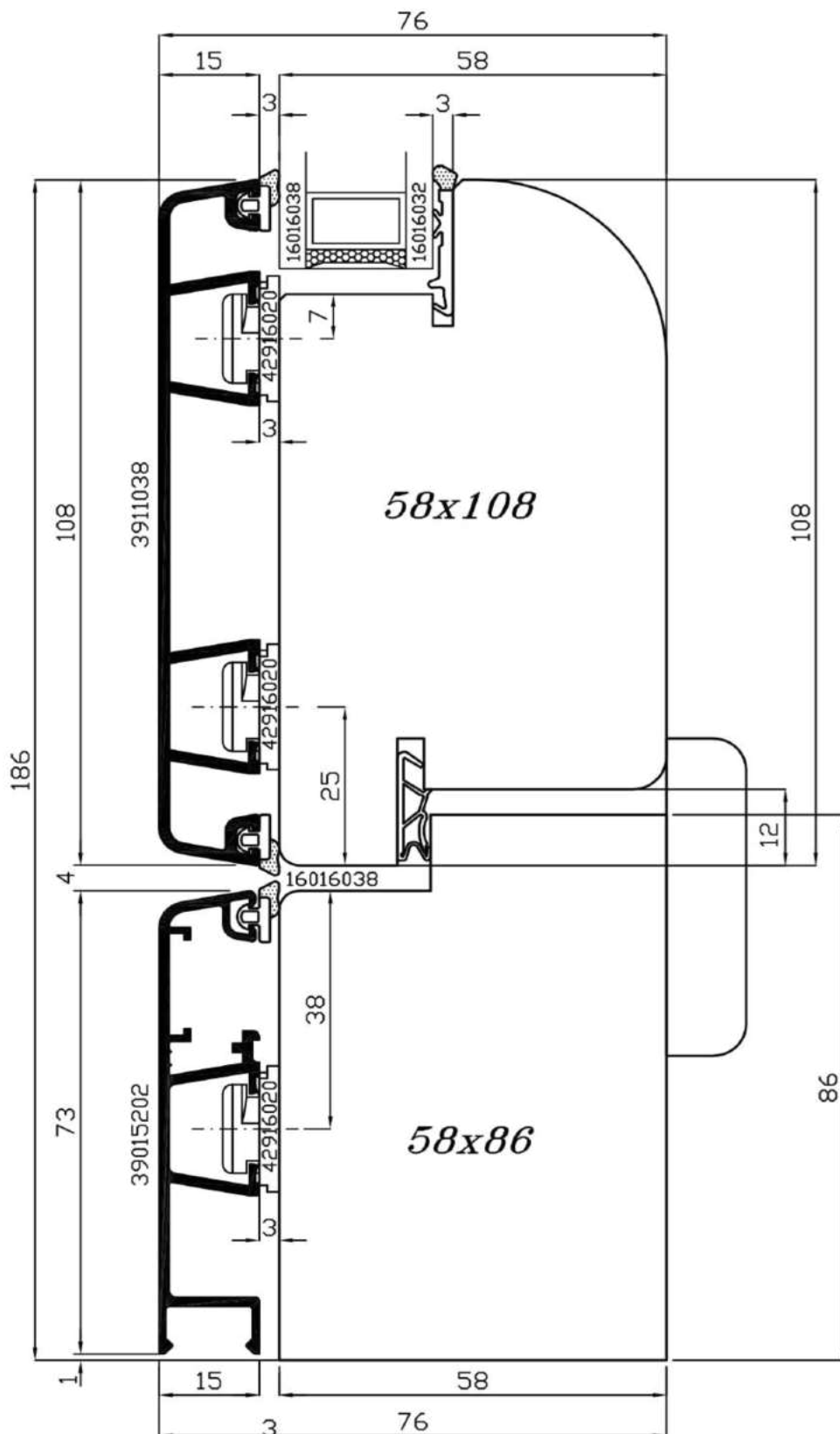

			Sistema <b>ASTRO 9</b>	09S
Ciente Standard			REV. 00	Scala Disegno 1:1
Descrizione: <b>SEZIONE VERTICALE TRAVERSO INFERIORE</b> Mod_35_REV01			Tolleranze Generali	± 0,5 mm
			PAGINA	

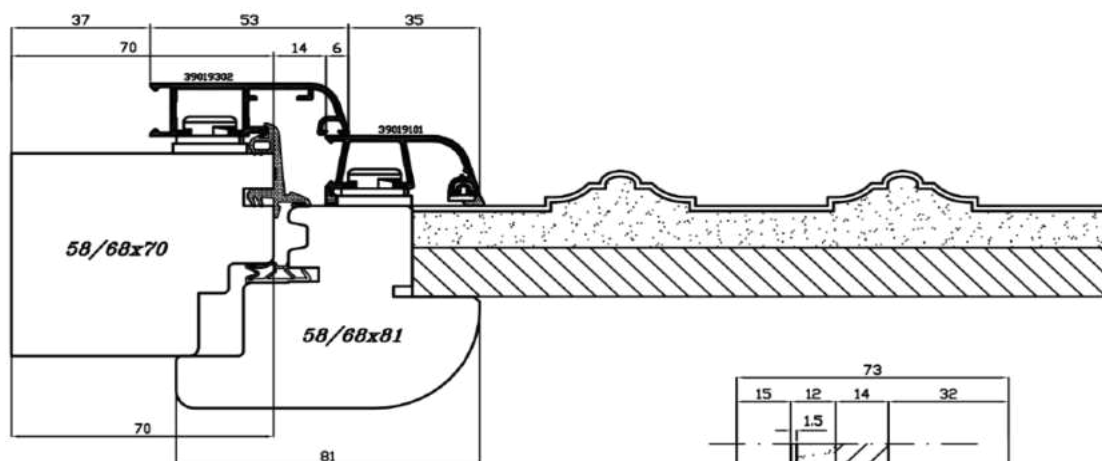

Spessore In Styrafoam

Laniera bugnata

Pannello di multistrati

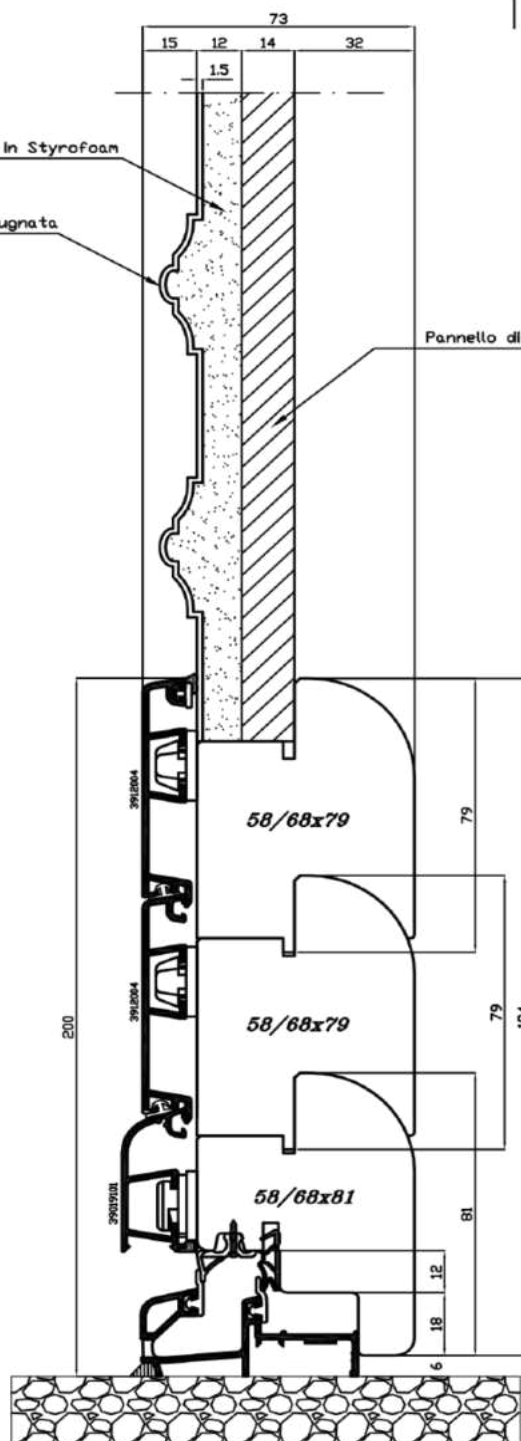
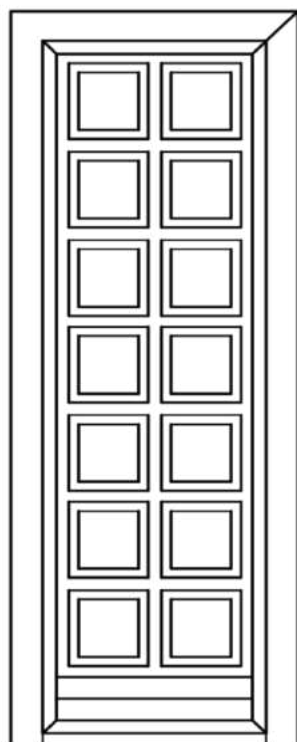

			Sistema <b>ASTRO 9</b>	09S
	Cliente Standard		REV. 00	Scala Disegno
Descrizione: <b>MONTAGGIO PANNELLO BUGNATO</b>			Tolleranze Generali	± 0,5 mm
Mod_35_REV01			PAGINA	

Terminale cod. 41419022  
 Terminale Dx+Sx per 39019003

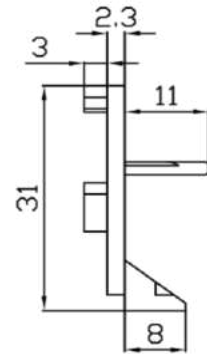
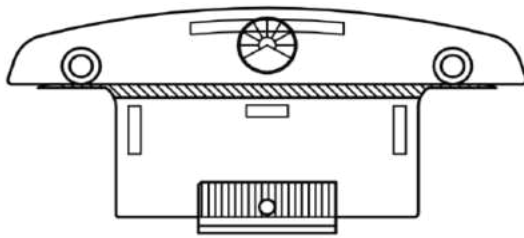

Terminale cod. 41419023  
 Terminale Dx+Sx per 39019103

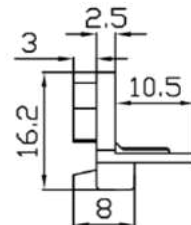
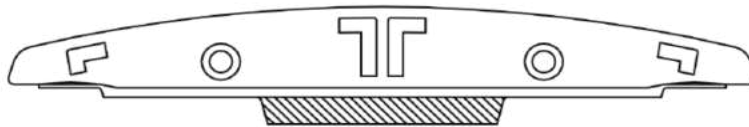

				Sistema Astro 9	09S
	Cliente Standard		REV. 05	Scala Disegno	1:1
Descrizione: <p style="text-align: center;"><b>ACCESSORI</b></p>				Tolleranze Generali	± 0,5 mm
Mod_35_REV01				PAGINA	



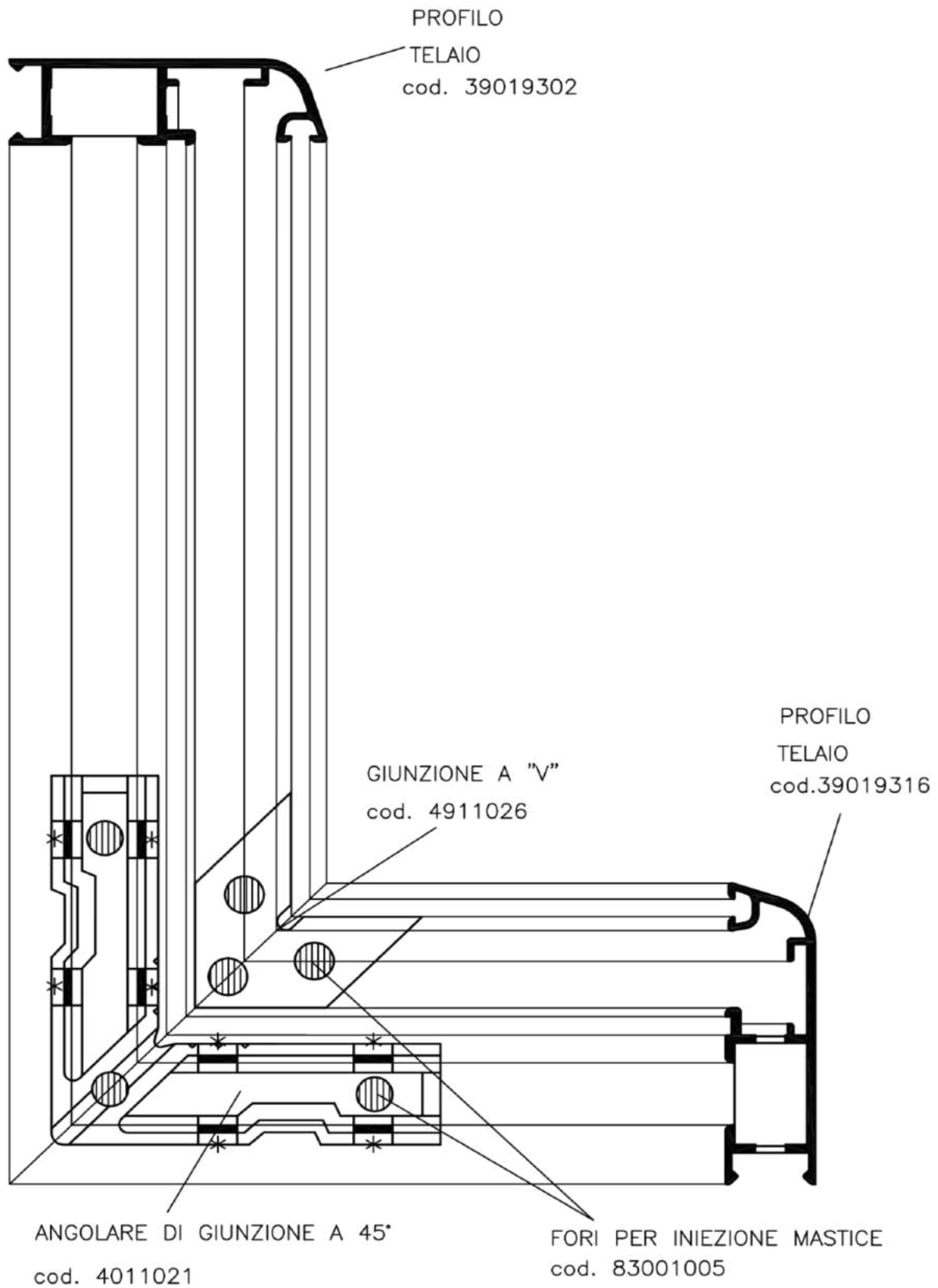

				Sistema Astro 9	09S
	Cliente Standard		REV. 05	Scala Disegno	1:1
Descrizione:				Tolleranze Generali	± 0,5 mm
<b>UNIONE PROFILO TELAIO</b>				<b>PAGINA</b>	

Mod\_35\_REV01

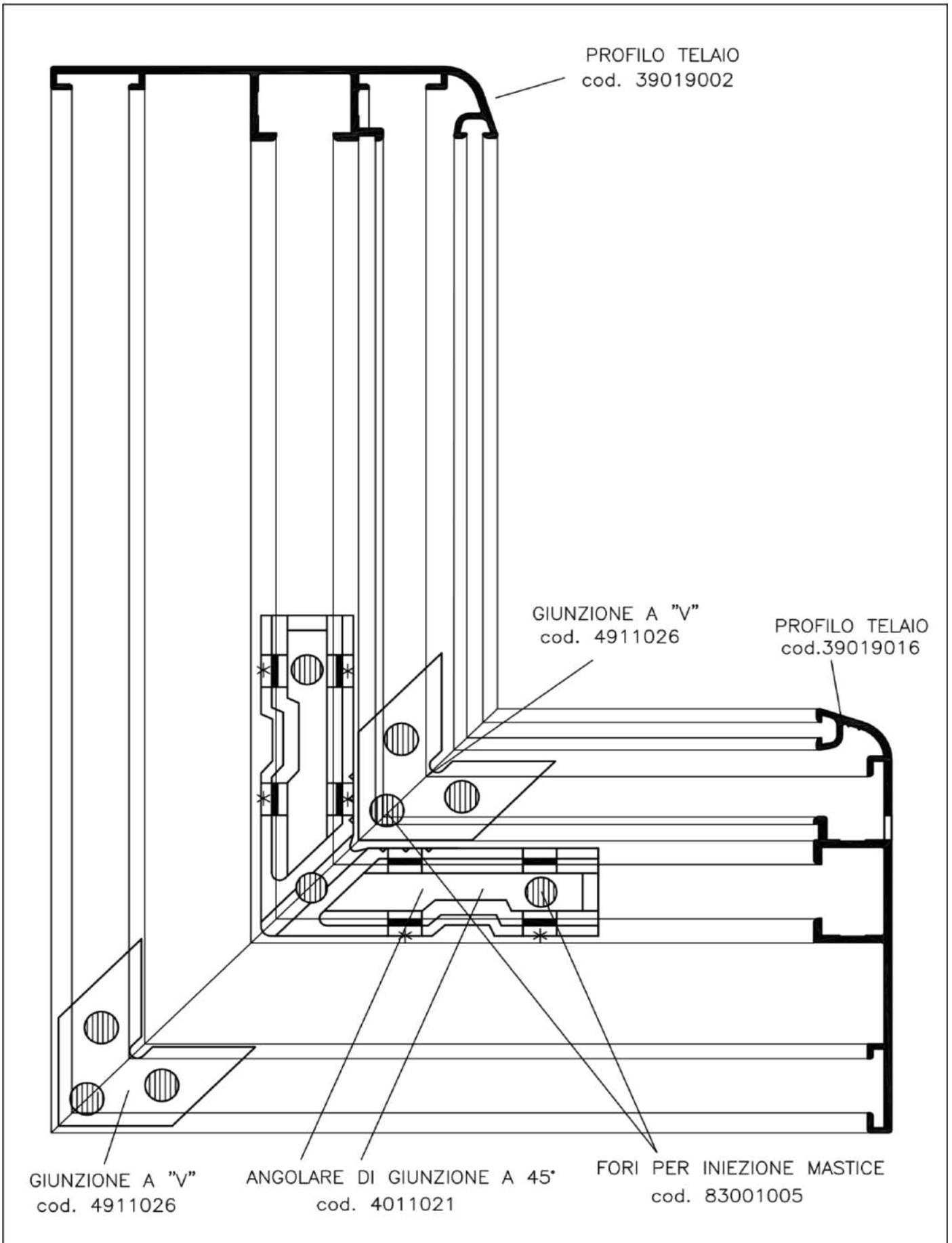

			Sistema Astro 9	09S
	Cliente Standard		REV. 05	Scala Disegno
Descrizione:			Tolleranze Generali	± 0,5 mm
<p align="center"><b>UNIONE PROFILO TELAIO</b></p>			<b>PAGINA</b>	

\*= POSIZIONE RELATIVA ALLA CIANFRINATURA

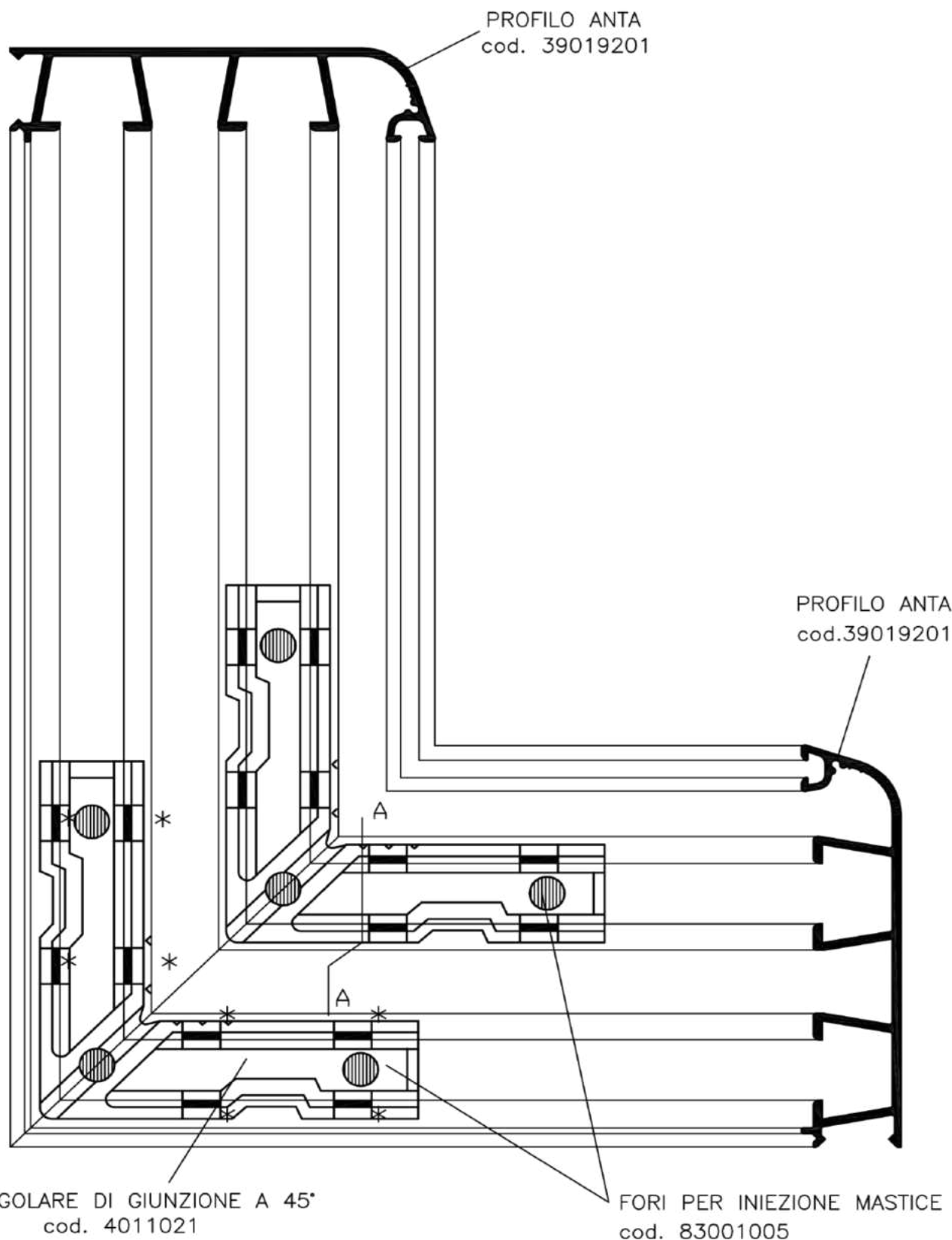

	Cliente Standard		REV. 05	Sistema Astro 9 09S
Descrizione: <b>UNIONE PROFILO TELAIO</b>				Scala Disegno 1:1
Mod_35_REV01				Tolleranze Generali ± 0,5 mm
				PAGINA

\*= POSIZIONE RELATIVA ALLA CIANFRINATURA

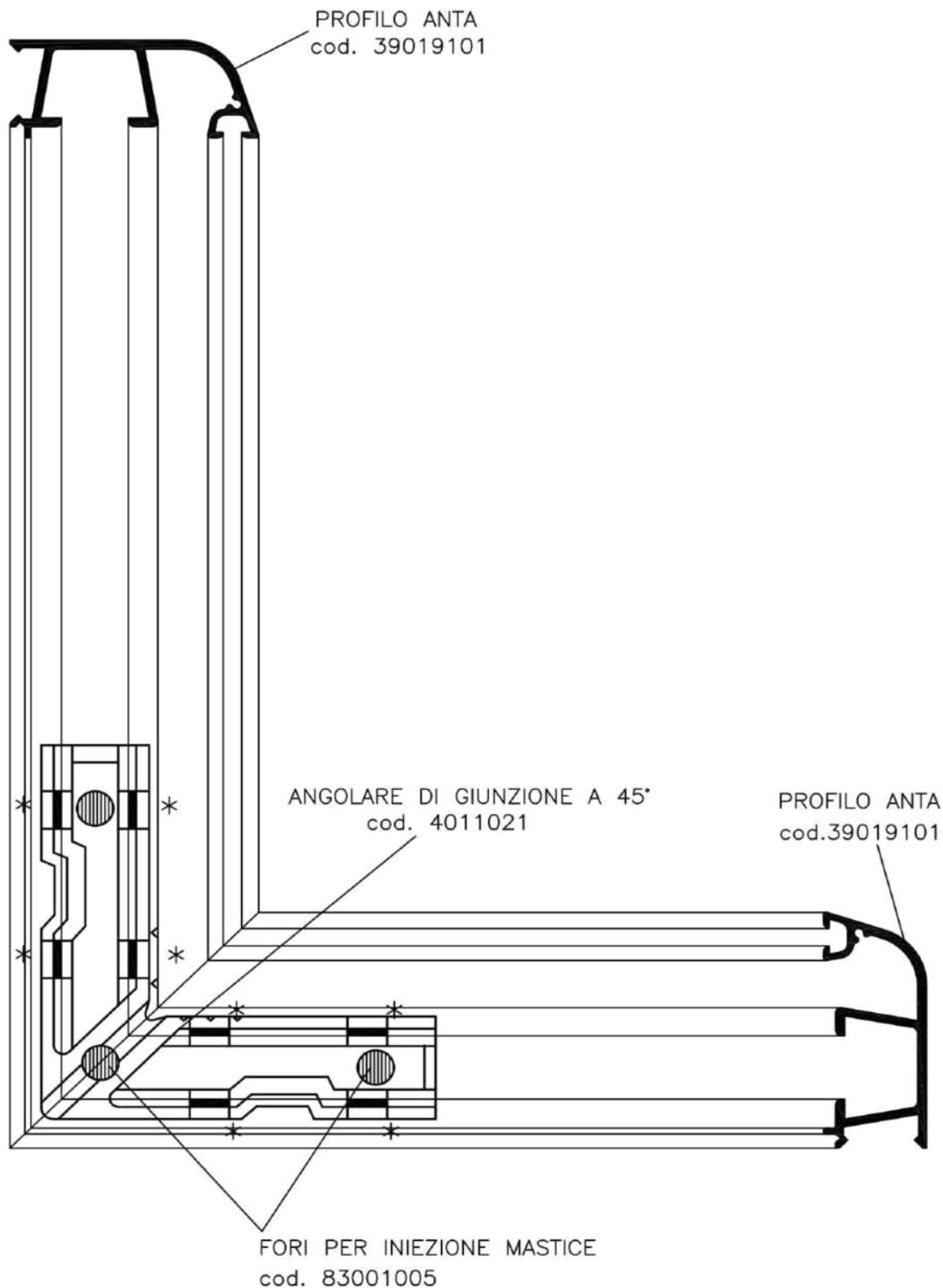

			Sistema Astro 9	09S
	Cliente Standard		REV. 05	Scala Disegno
Descrizione:			Tolleranze Generali	± 0,5 mm
<p style="text-align: center;"><b>UNIONE PROFILO ANTA</b></p>			<b>PAGINA</b>	

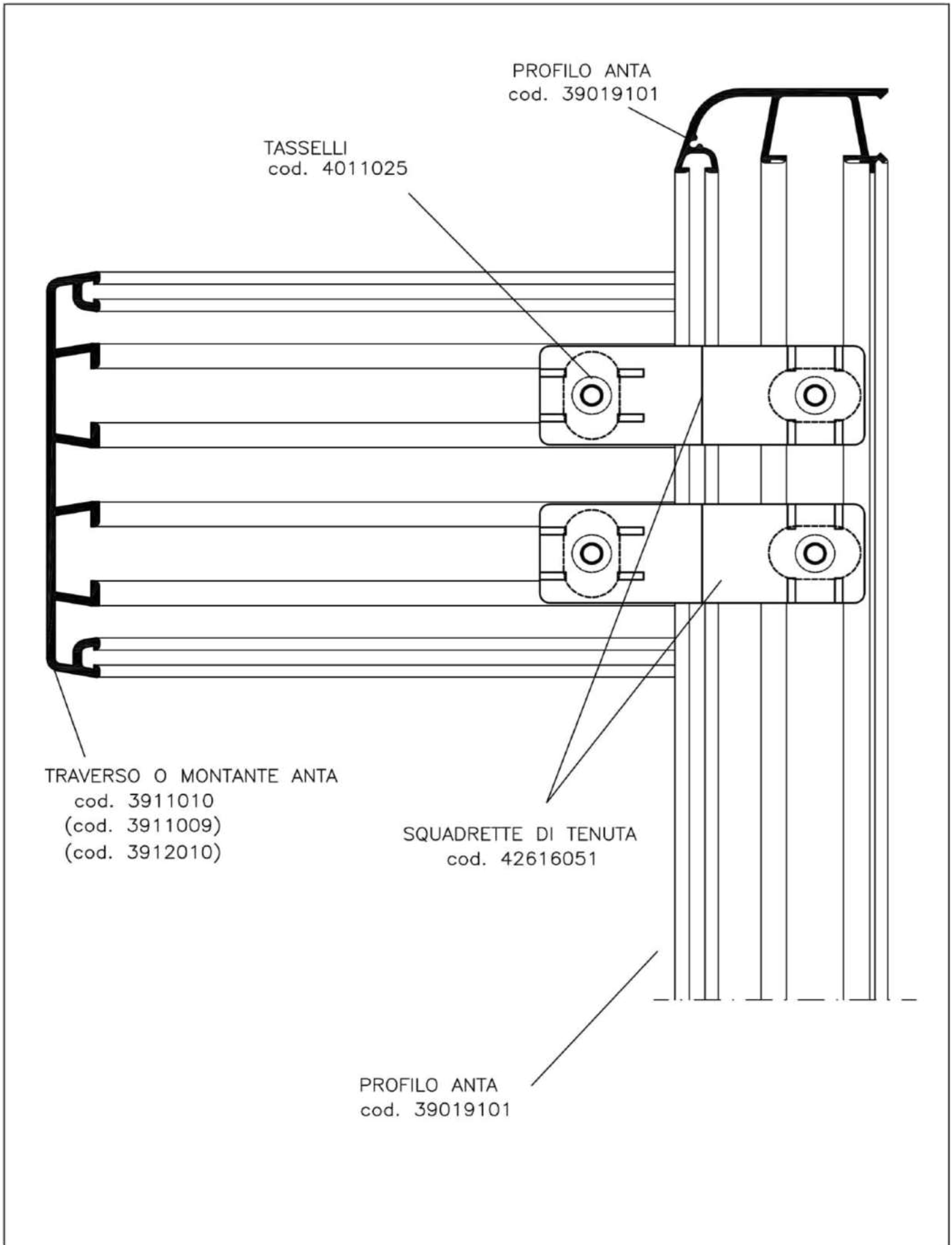

				Sistema Astro 9	09S
	Cliente Standard		REV. 05	Scala Disegno	1:1
Descrizione: <p style="text-align: center;"><b>ESEMPIO DI MONTAGGIO</b></p>				Tolleranze Generali	± 0,5 mm
Mod_35_REV01				PAGINA	-

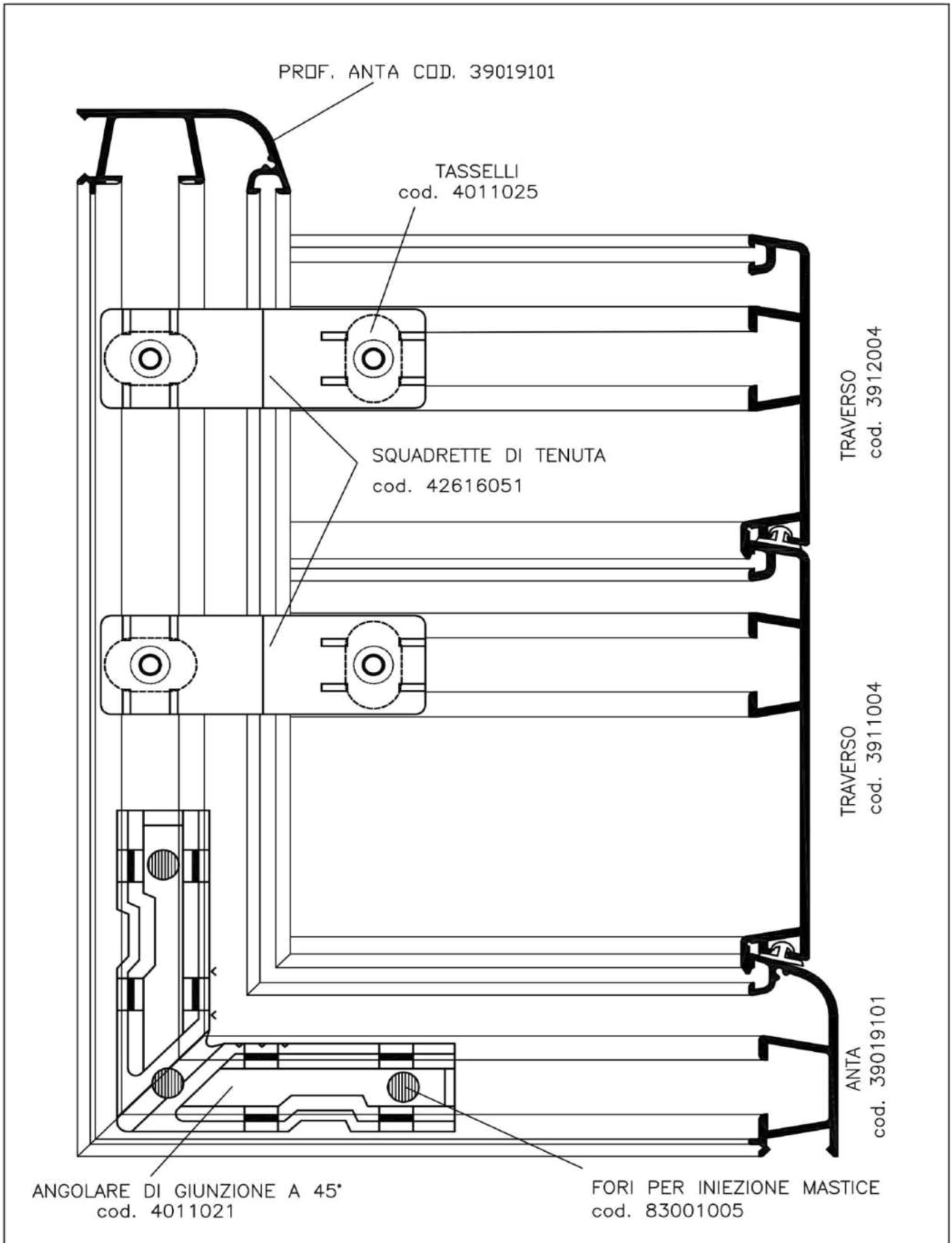

			Sistema Astro 9	09S
	Cliente Standard		REV. 05	Scala Disegno
Descrizione: <b>UNIONE PROFILO ZOCCOLO SU ANTA</b>			Tolleranze Generali	± 0,5 mm
			PAGINA	

Mod\_35\_REV01



39019007

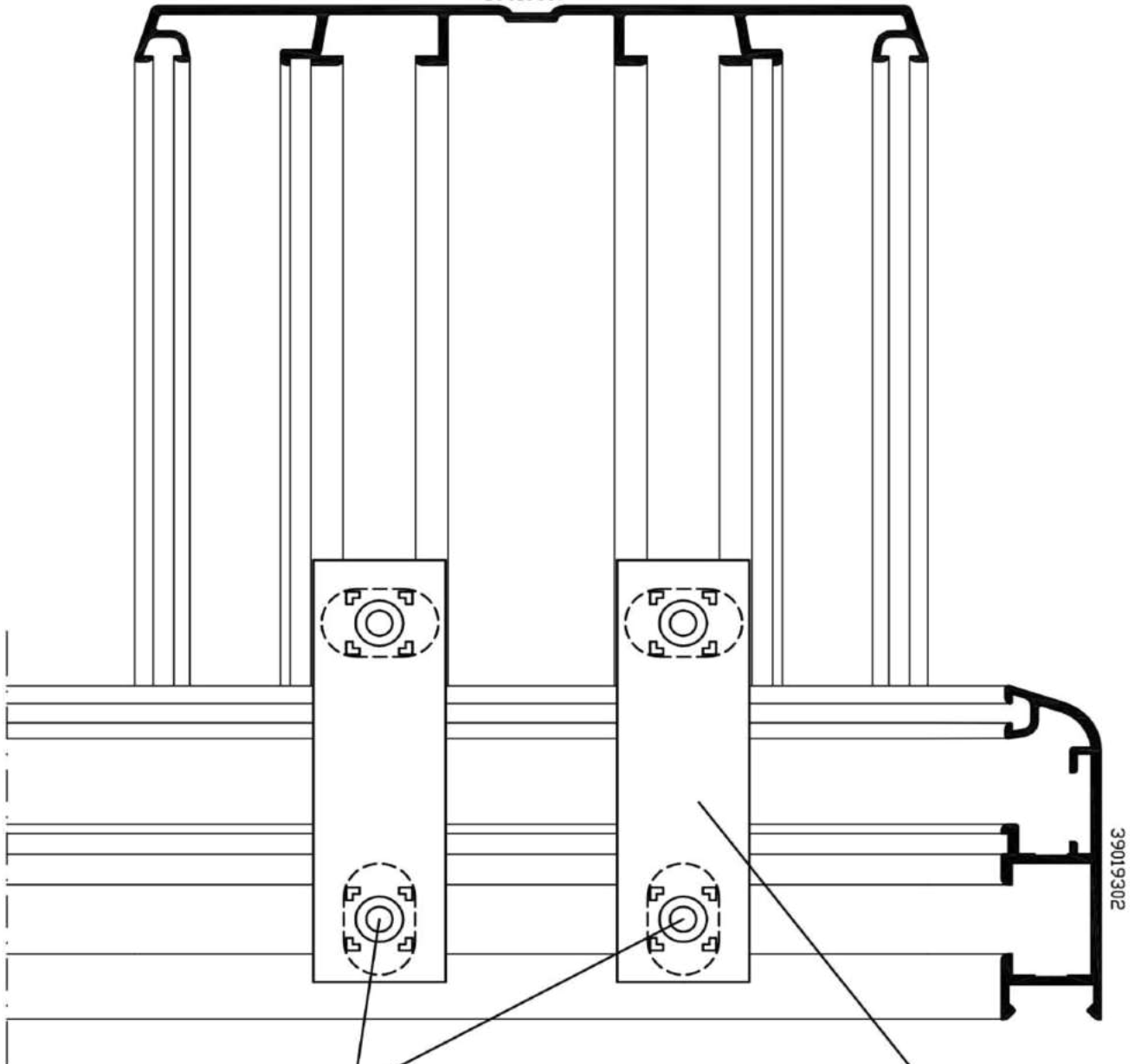

TASSELLI  
cod. 4011025

SQUADRETTA DI TENUTA  
cod. 42616051-1

			Sistema Astro 9	09S
	Cliente Standard		REV. 05	Scala Disegno
Descrizione: <b>UNIONE PROFILO PER INGLESINA</b>			Tolleranze Generali	---
			PAGINA	

Mod\_35\_REV01

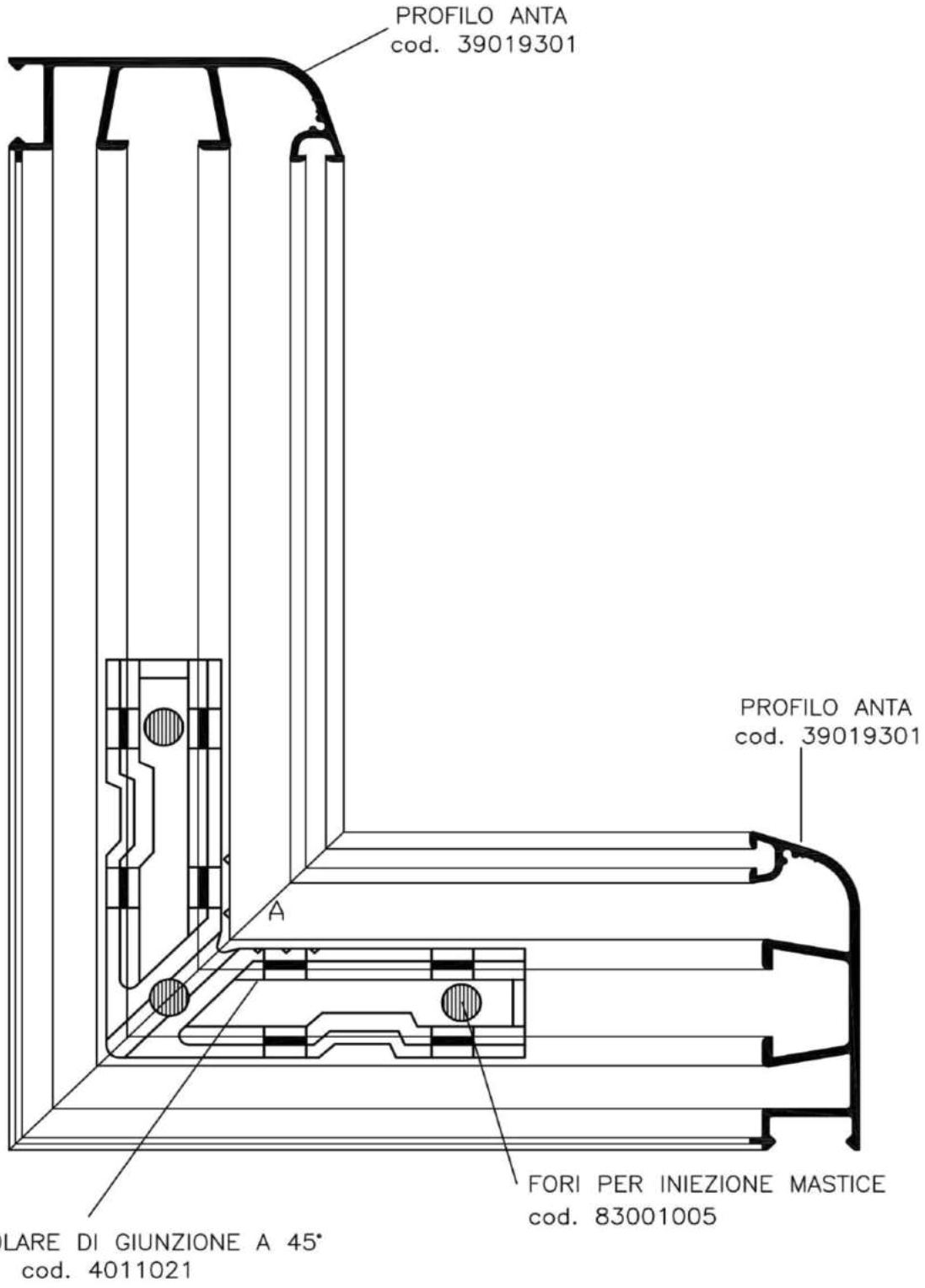

			Sistema Astro 9	09S
	Cliente Standard		REV. 05	Scala Disegno
Descrizione: <p style="text-align: center;"><b>ESEMPIO DI MONTAGGIO</b></p>			Tolleranze Generali	± 0,5 mm
			PAGINA	

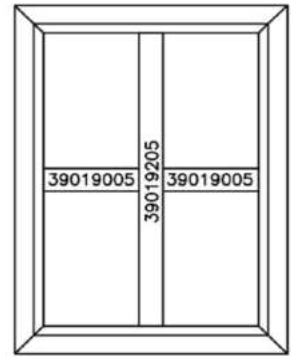
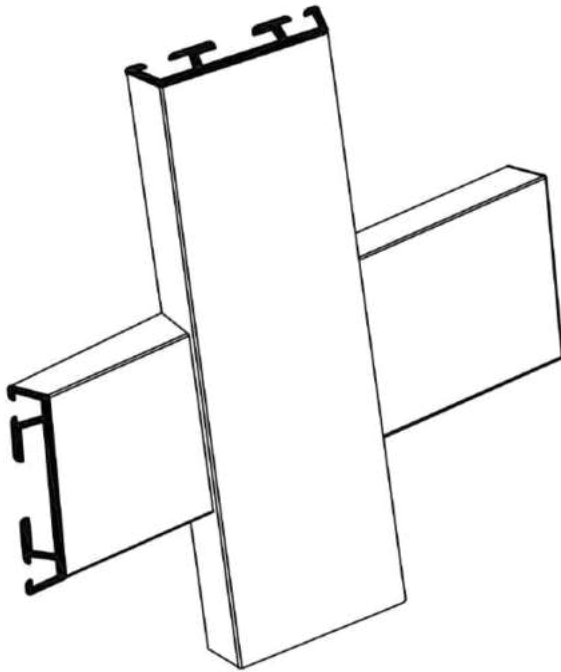

F1A

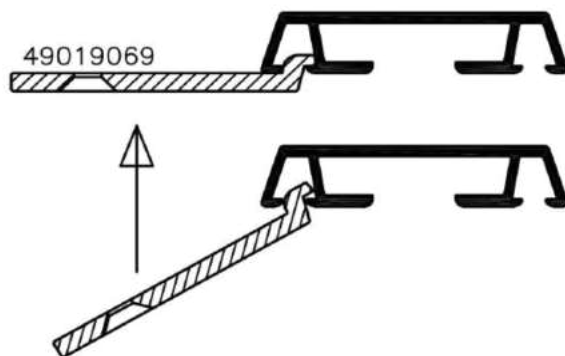
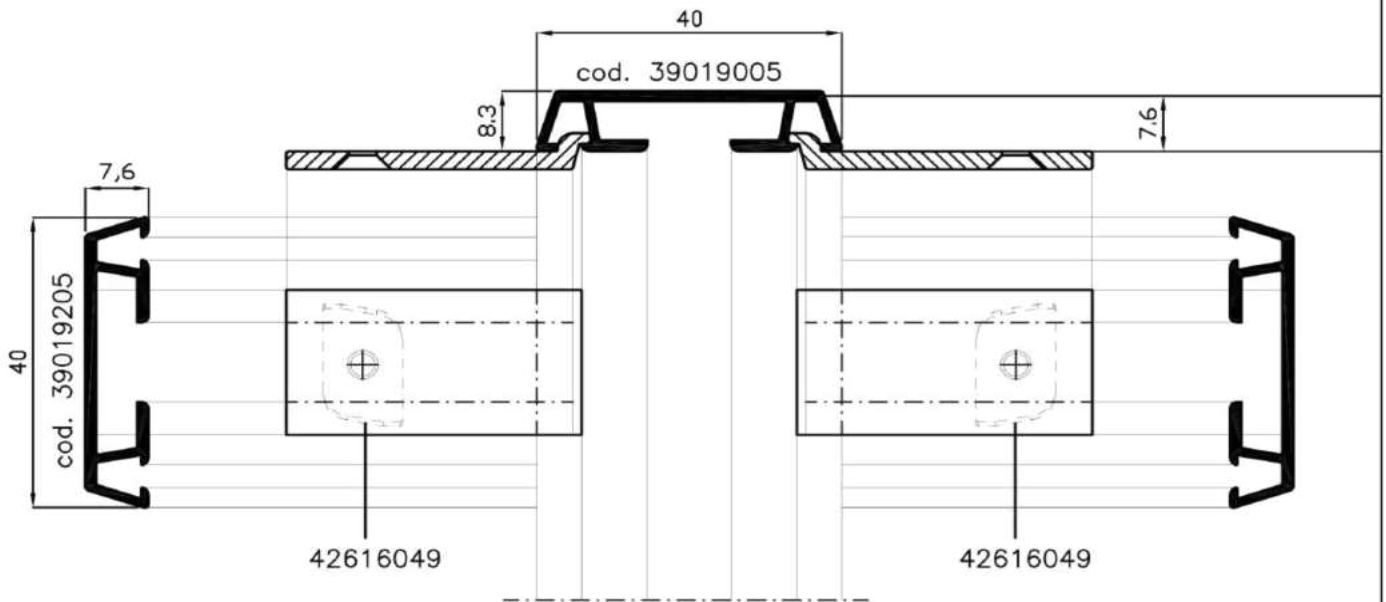

*Per l'aggancio utilizzare vite passo metrico esagono incassato M5x6*

			Sistema Astro 9	09S
	Cliente Standard		REV. 05	Scala Disegno
Descrizione: <b>UNIONE CENTRALE CROCE INGLESINA</b>			Tolleranze Generali	± 0,5 mm
Mod_35_REV01			PAGINA	

39019007

39019302

TASSELLI  
cod. 4011025

SQUADRETTA DI TENUTA  
cod. 42616051

			---	Sistema Astro 9	09S
	Cliente Standard		REV. 05	Scala Disegno	1:1
Descrizione:				Tolleranze Generali	---
<b>UNIONE PROFILO MONT. CENTRALE</b>				<b>PAGINA</b>	

Mod\_35\_REV01

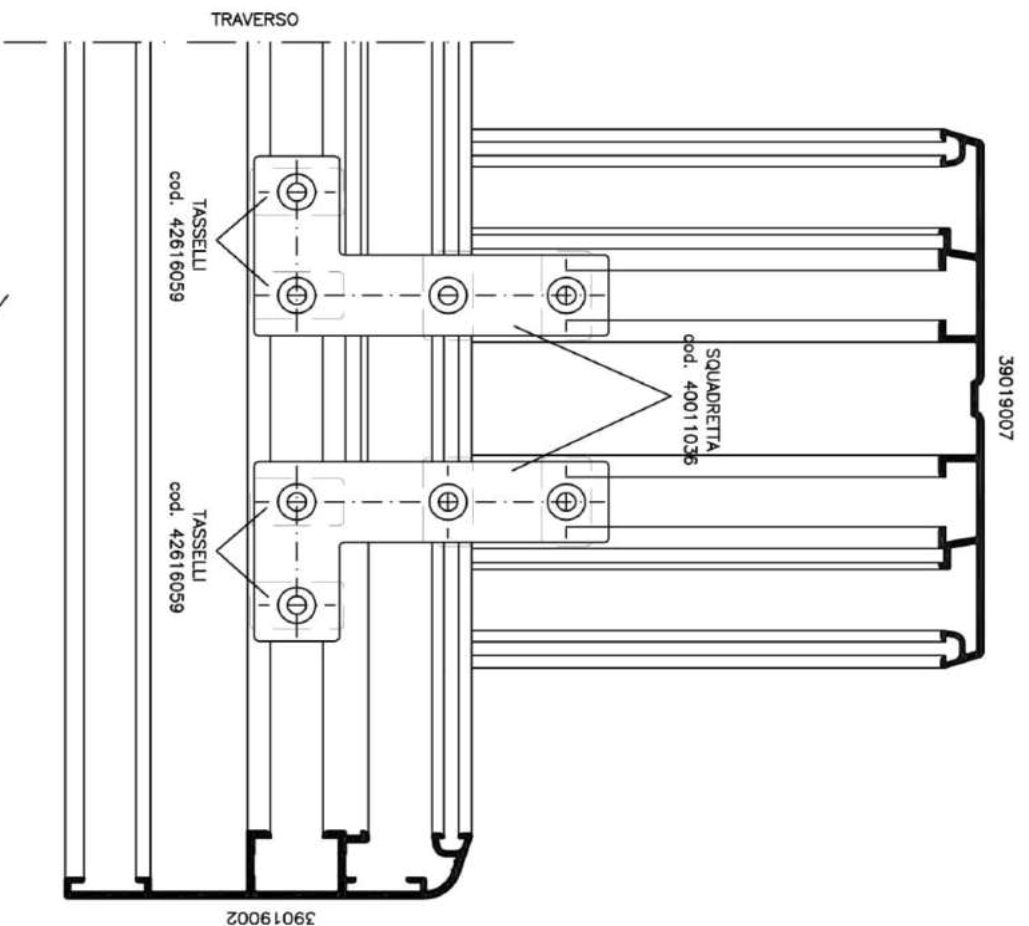
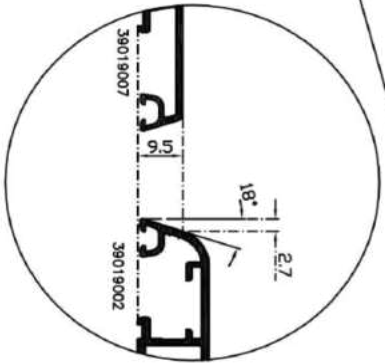
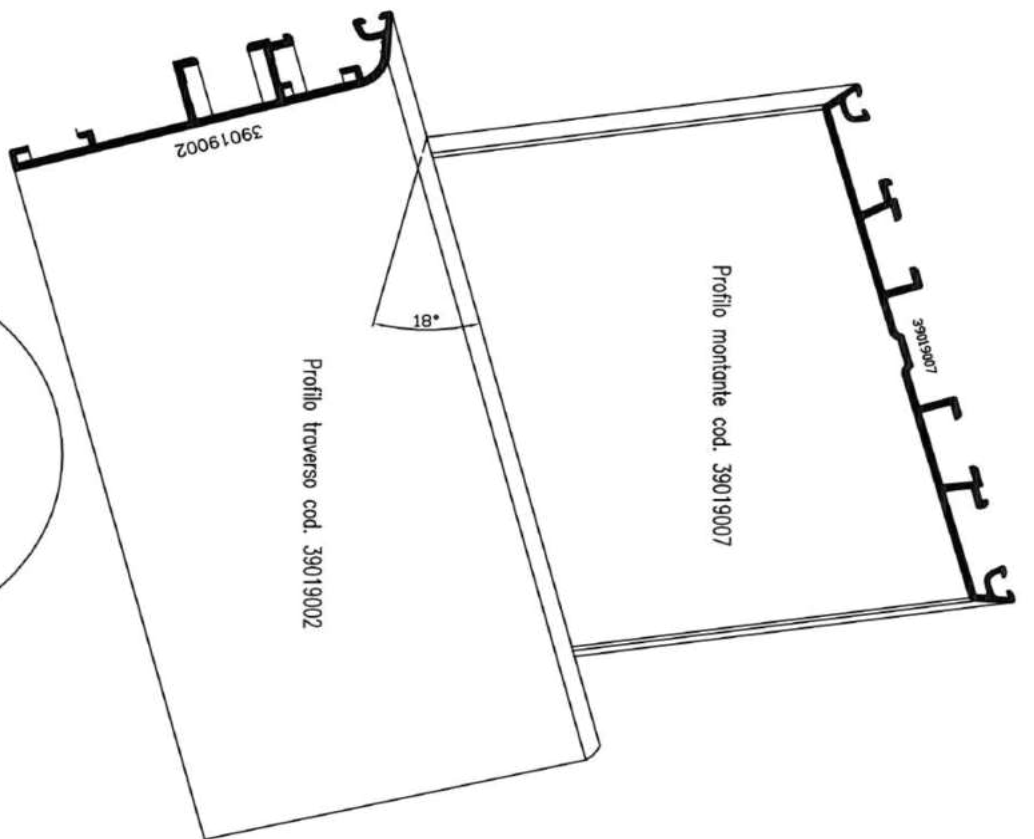

	Cliente Standard		REV. 05	Sistema Astro 9	095
				Scala Disegno	Fuori Scala
				Tolleranze Generali	---

Descrizione:  
**UNIONE PROFILO TELAIO - MONT. CENTRALE**  
 PAGINA

# MONTAGGIO IN LUCE

## FASI DI MONTAGGIO

- 1\*) Pulizia sia della parte in muratura sia dell'infisso
- 2\*) Eseguire un filo di silicone sul davanzale
- 3\*) Fissare la finestra
- 4\*) fissare angolare e siliconare
- 5\*) Iniettare schiuma poliuretamica

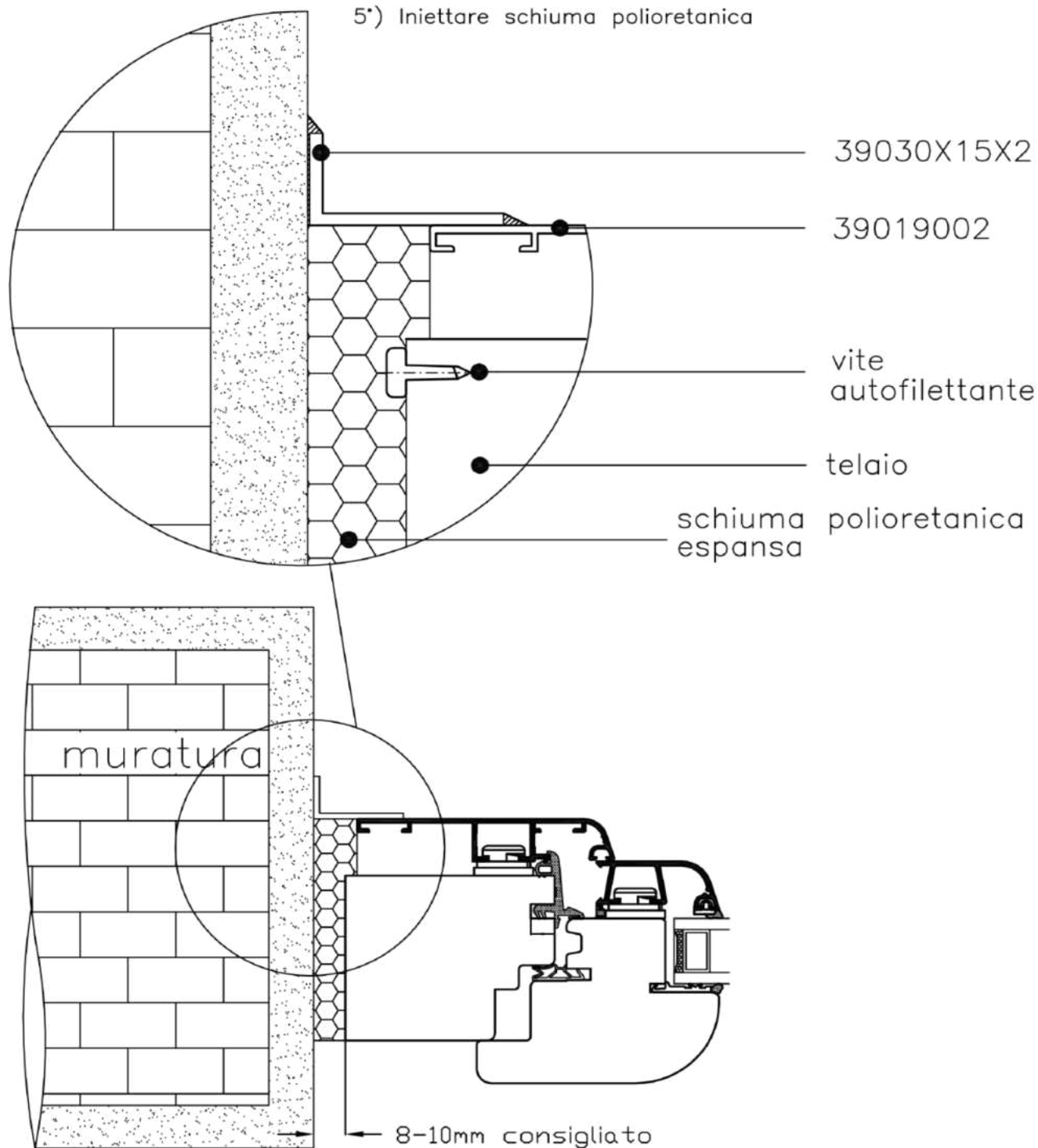

			Sistema <b>ASTRO 9</b>	09S
	Cliente Standard		REV. 05	Scala Disegno
Descrizione: <h2 style="text-align: center;">ESEMPI DI MONTAGGIO</h2>			Tolleranze Generali	---
			PAGINA	



# MONTAGGIO IN MAZZETTA

## FASI DI MONTAGGIO

- 1\*) Pulizia sia del controtelaio sia dell'infisso
- 2\*) Eseguire un filo di silicone su 4 lati
- 3\*) Fissare la finestra
- 4\*) Iniettare schiuma poliuretamica

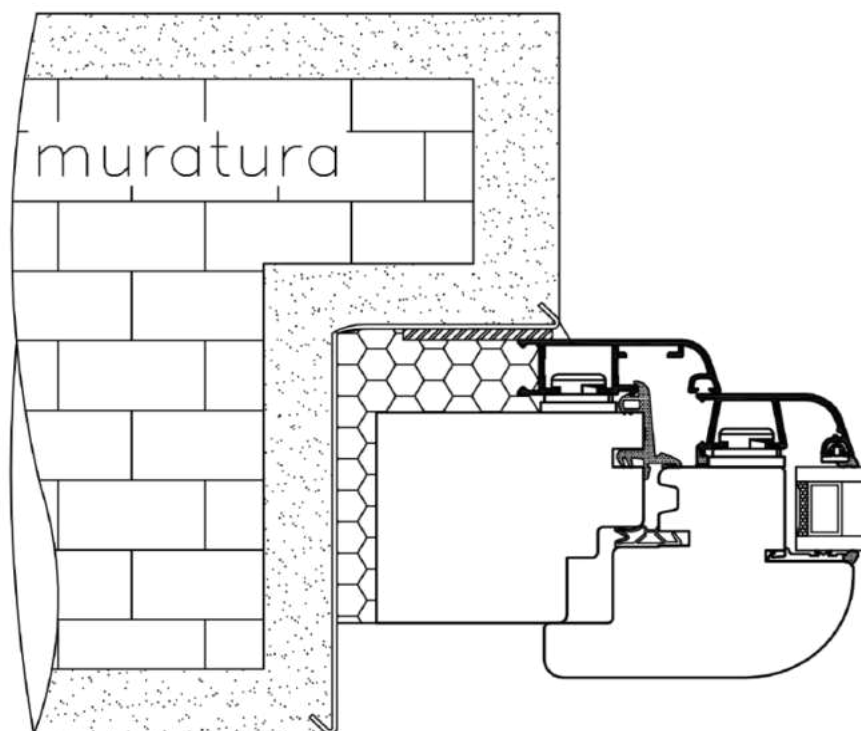
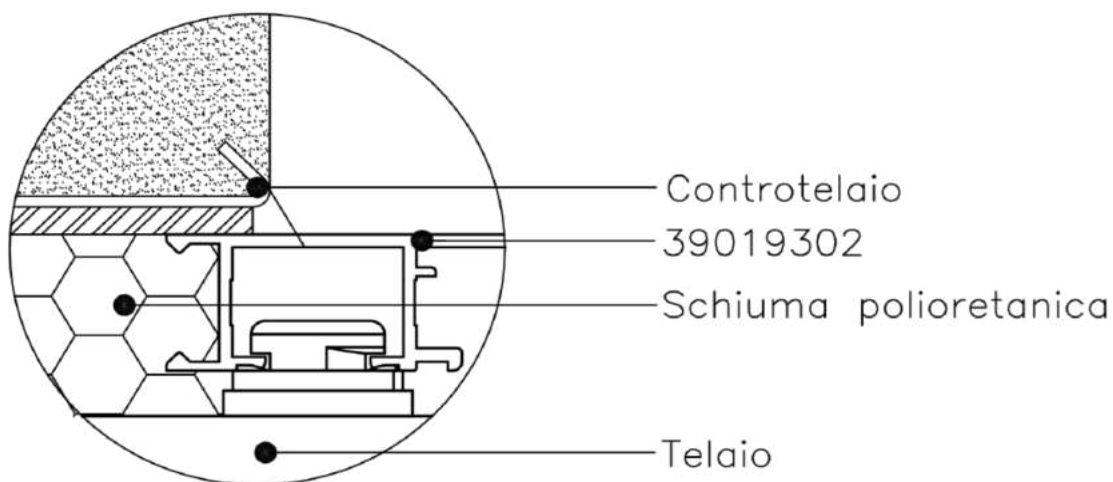

				Sistema Astro 9	09S
	Cliente Standard			REV. 05	Scala Disegno
Descrizione:				Tolleranze Generali	---
<b>ESEMPI DI MONTAGGIO</b>				PAGINA	

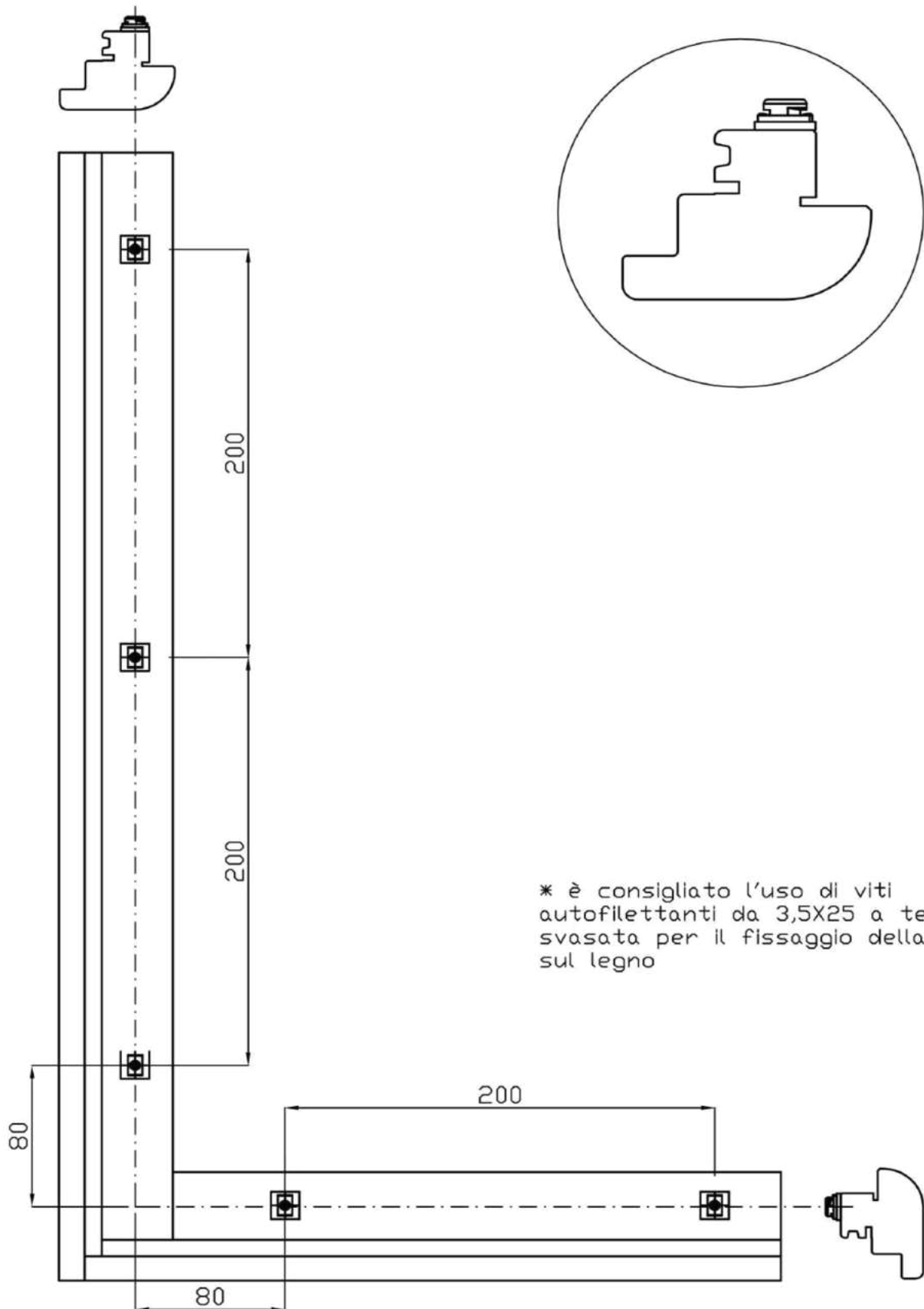

				Sistema Astro 9	09S
	Cliente Standard		REV. 05	Scala Disegno	Fuori Scala
Descrizione: <b>DISPOSIZIONE MONTAGGIO CLIPS COD.42519020</b>			Tolleranze Generali ---		
Mod_35_REV01			PAGINA		

ATTENZIONE:  
 FISSARE TRAMITE  
 CLIPS COD.42319043  
 IL PROF. COD.  
 39019003  
 DOPO AVER FISSATO  
 IL PROF. ANTA  
 COD. 39019101

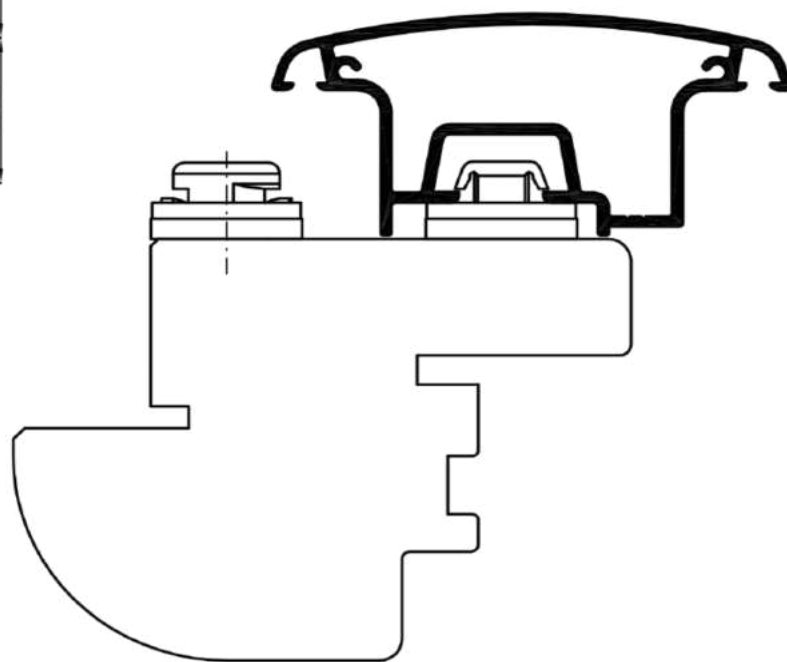
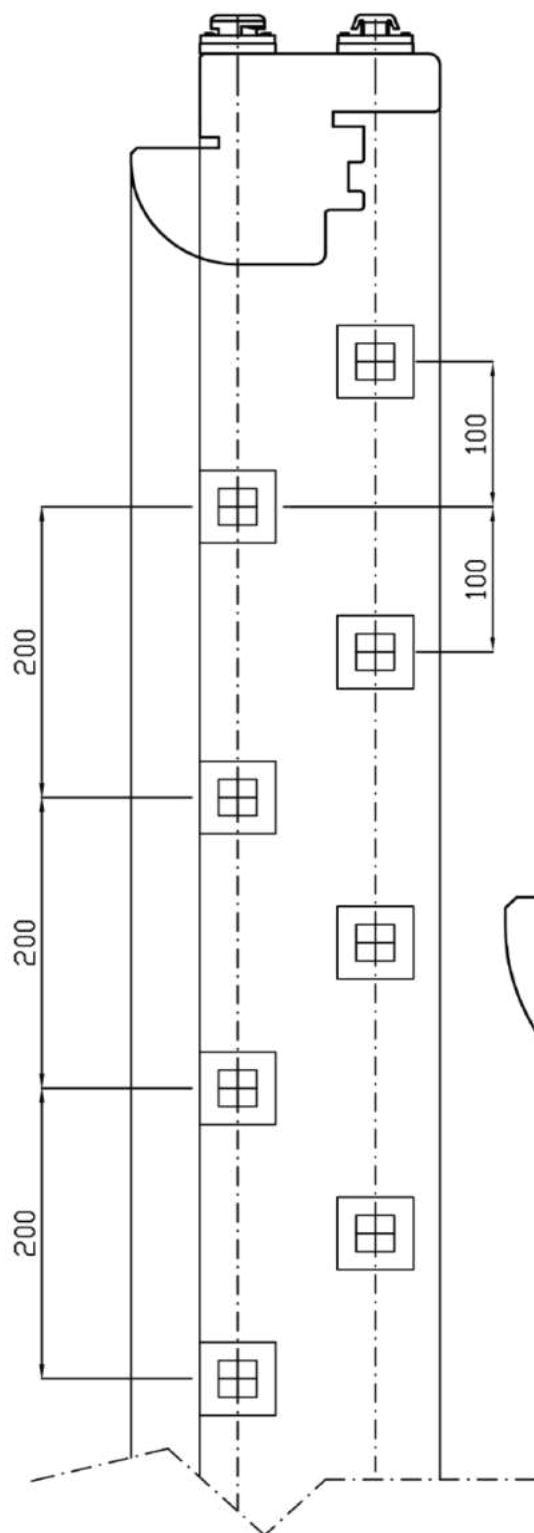

\* è consigliato l'uso di viti autofilettanti da 3,5X25 a testa svasata per il fissaggio della clips sul legno

			Sistema Astro 9	09S
	Cliente Standard		REV. 05	Scala Disegno
Descrizione: <b>DISPOSIZIONE MONTAGGIO CLIPS SU MONTANTE</b>			Tolleranze Generali	± 0,5 mm
			PAGINA	

Profilo Telaio

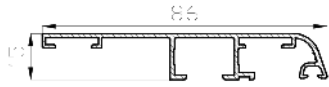

39019002

Profilo Montantino

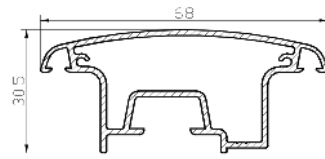

39019003

Profilo Traverso inferiore

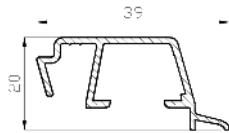

39019006

Profilo Traverso inferiore

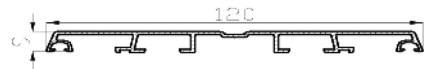

39019007

Profilo Telaio forato

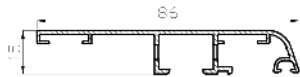

39019016

Profilo Pannello bugnato

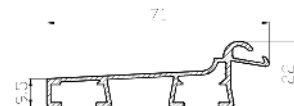

39019070

Profilo Anta

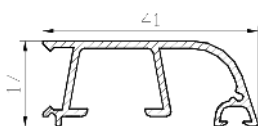

39019101

Profilo Telaio Monoclip

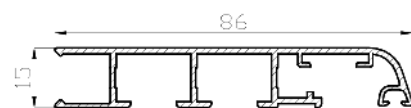

39019102

Profilo Montantino



39019103

Profilo Anta Larga

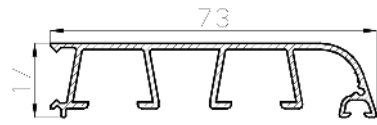

39019201



# ALZANTE SCORREVOLE

H 12

W  
O  
O  
D

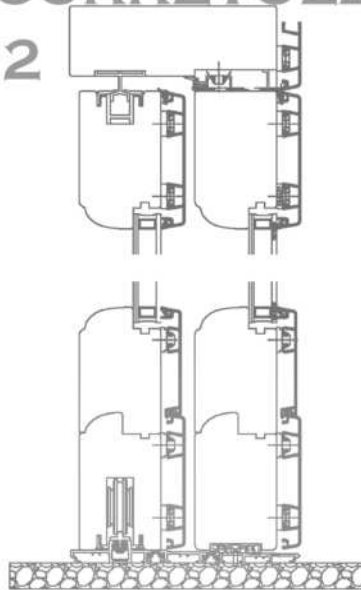

SYSTEM

ALL

OLTRE  
CIO' CHE VEDI!



ALZANTE SCORREVOLE ANTA FISSA-APRIBILE

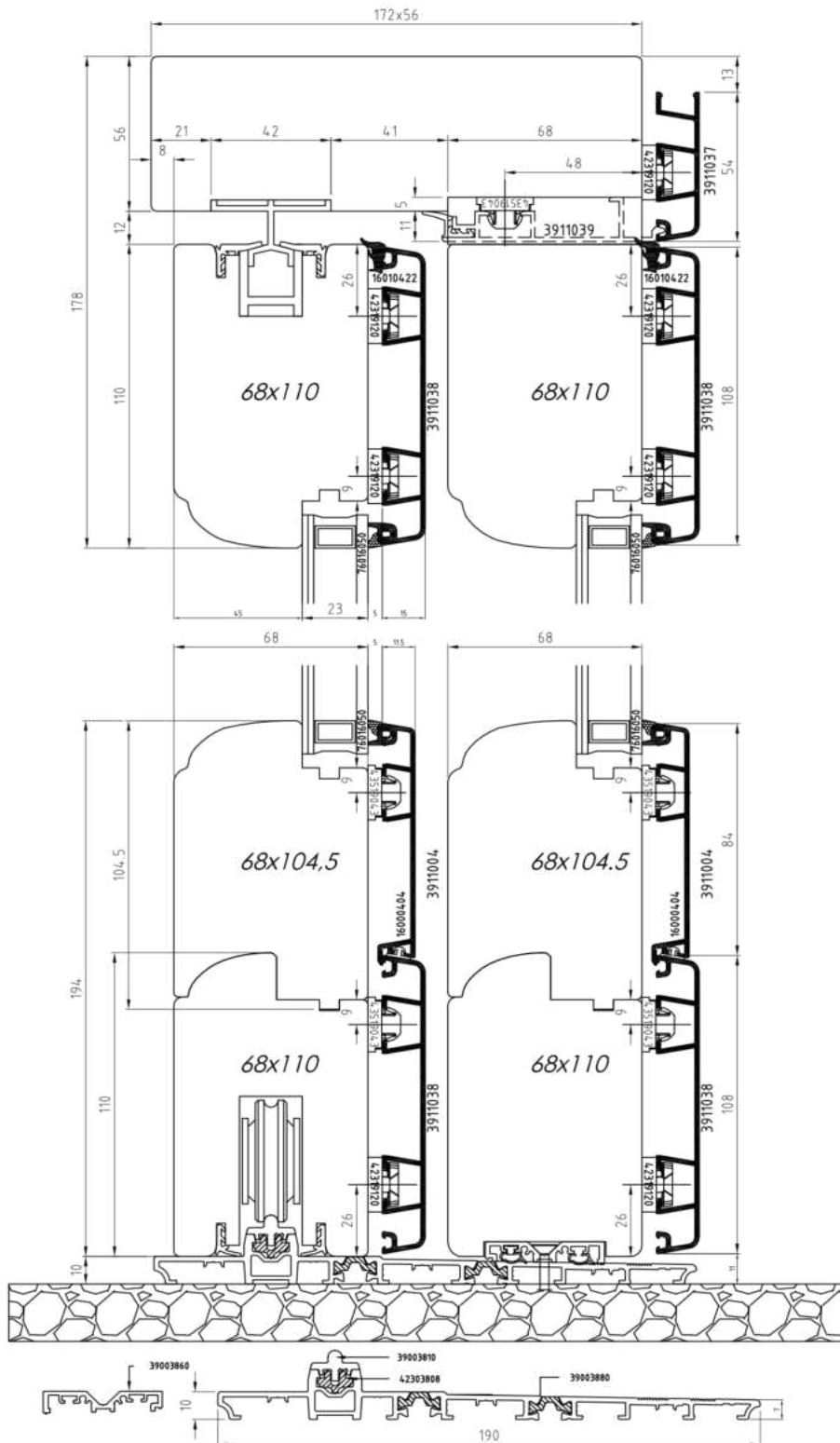
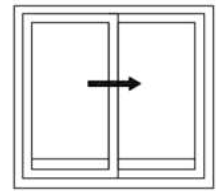

Sistema: <b>ASTRO 1</b>	Scala: <b>1:2.5</b>	Revisione e data :	Tavola: <b>HS100</b>
Descrizione : <b>SEZIONE VERTICALE ALZANTE SCORREVOLE</b>			
Data emissione:	Nome File: <b>ALZ_REV.01</b>	n° Pagina <b>pag. 4</b>	

ALZANTE SCORREVOLE ANTA FISSA-APRIBILE

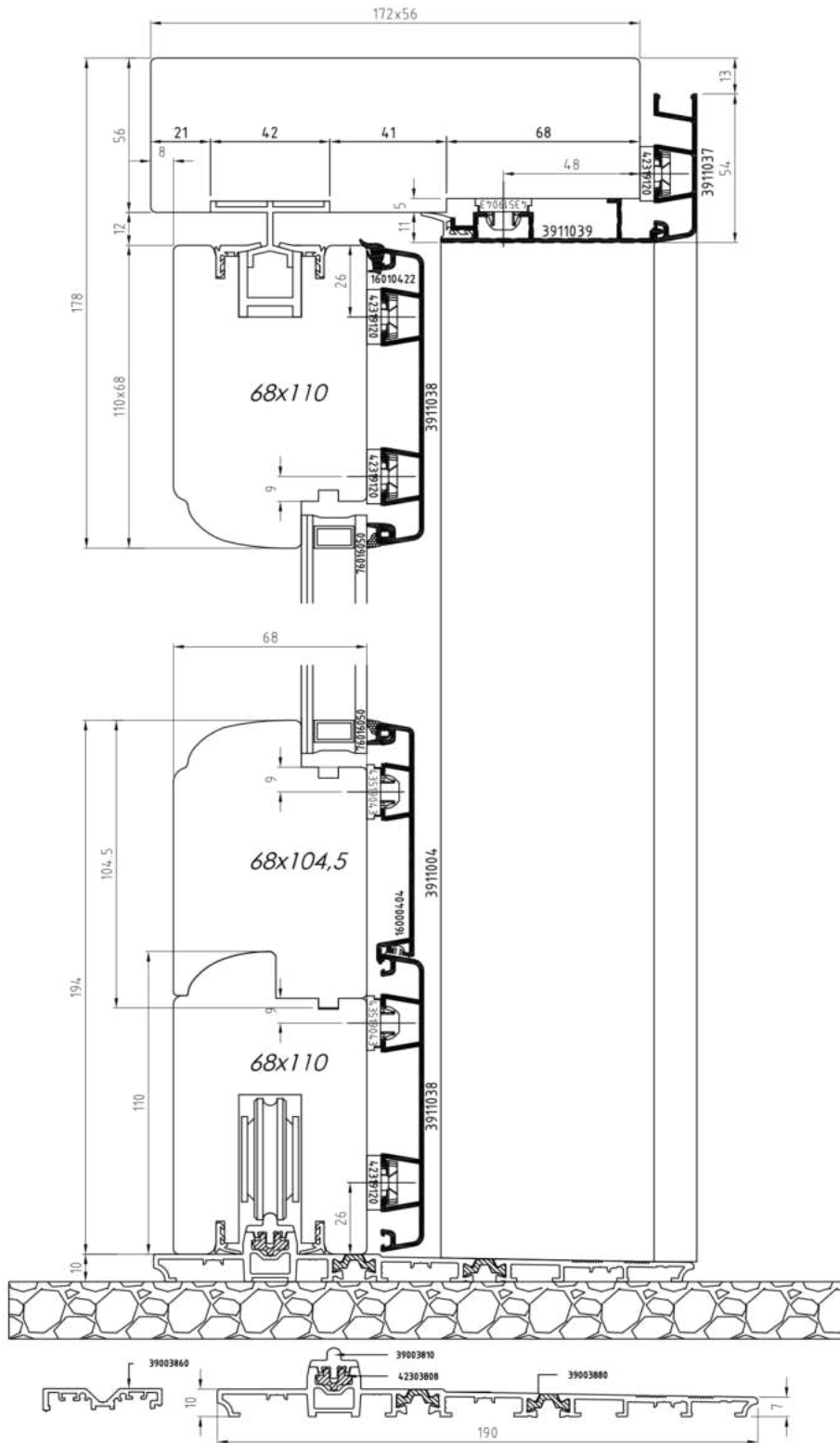
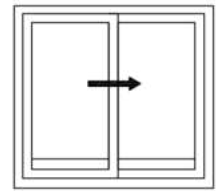

Sistema:

**ASTRO 1**

Scala:

**1:2.5**

Revisione e data :

Tavola:

**HS200**

Descrizione :

**SEZIONE VERTICALE ALZANTE SCORREVOLE**

Data emissione:

Nome File:

**ALZ\_REV.01**

n° Pagina

**pag. 5**

ALZANTE SCORREVOLE ANTA FISSA-APRIBILE

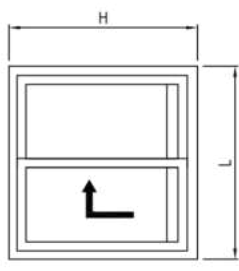
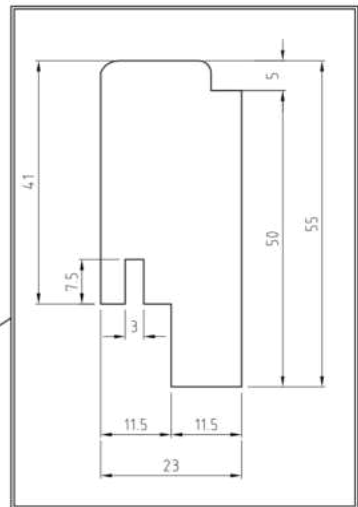
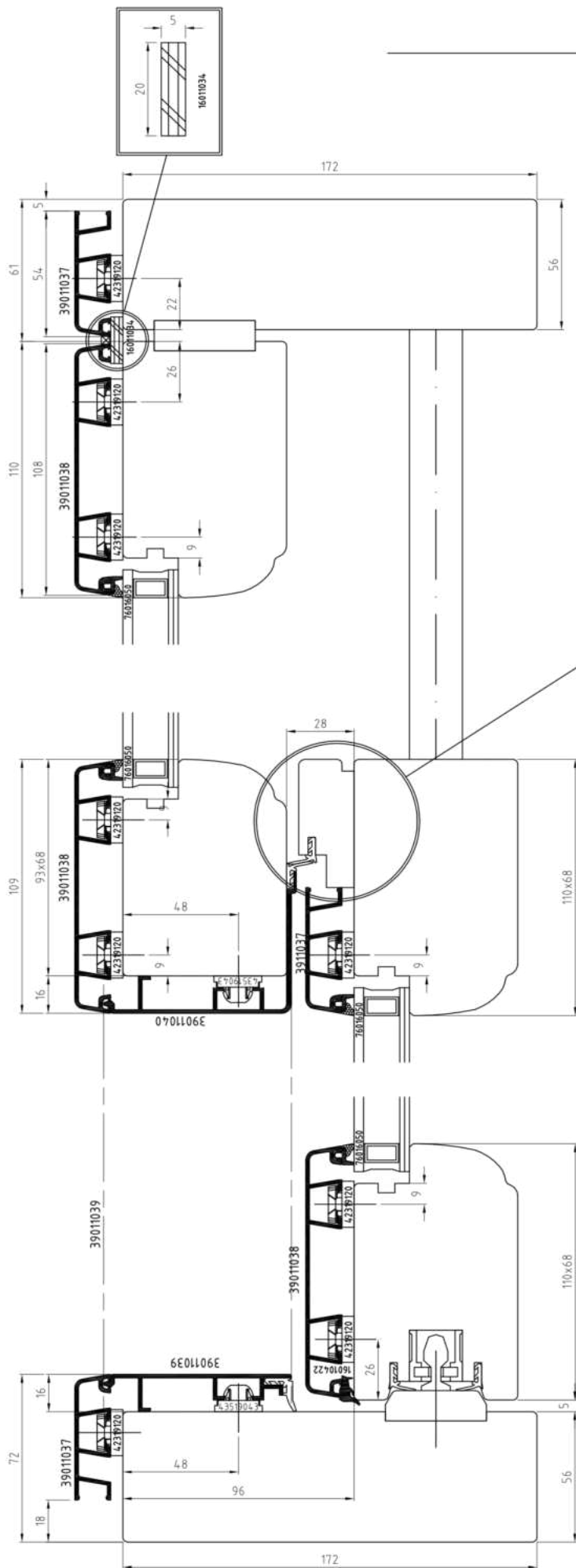

ASTRO 1 - sezioni

Alzante scorrevole  
anta fisso - apribile

Sistema:	ASTRO 1	Revisione e data :	Tavola:
Descrizione :	SEZIONE ORIZZONTALE ALZANTE SCORREVOLE	Scala:	HS300
Data emissione:	ALZ_REV.01	Nome File:	n° Pagina





# ALZANTE SCORREVOLE

H 27

W  
O  
O  
D

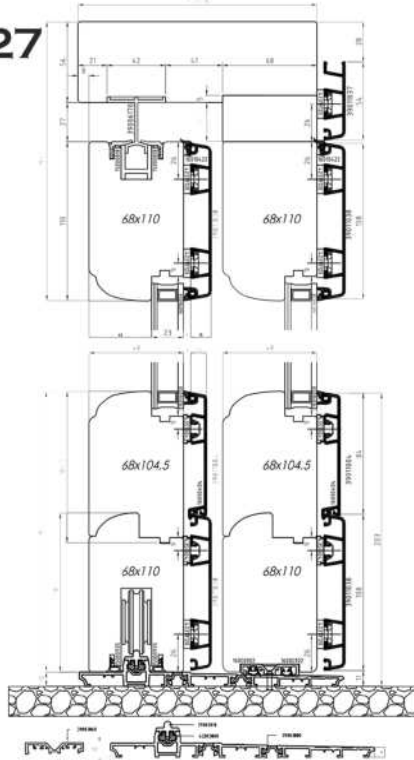

ALL

SYSTEM

OLTRE  
CIO' CHE VEDI!

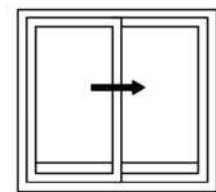
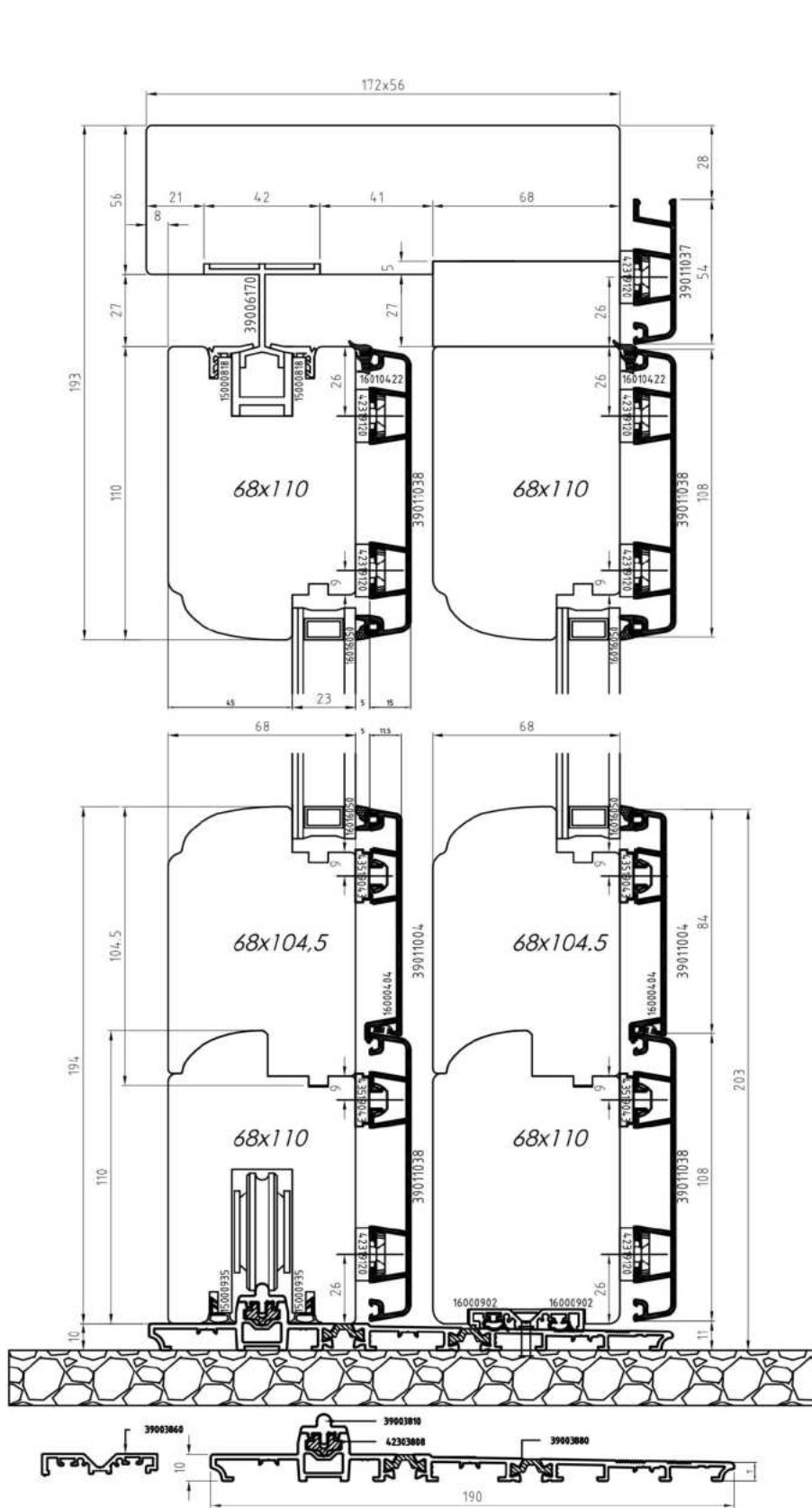

Sistema: <b>ASTRO 1</b>	Scala: <b>1:2.5</b>	Revisione e data :	Tavola: <b>HS110</b>
Descrizione : <b>SEZIONE VERTICALE ALZANTE SCORREVOLE</b>			
Data emissione:	Nome File: <b>ALZ_REV.07</b>	n° Pagina	





ALZANTE SCORREVOLE ANTA FISSA-APRIBILE

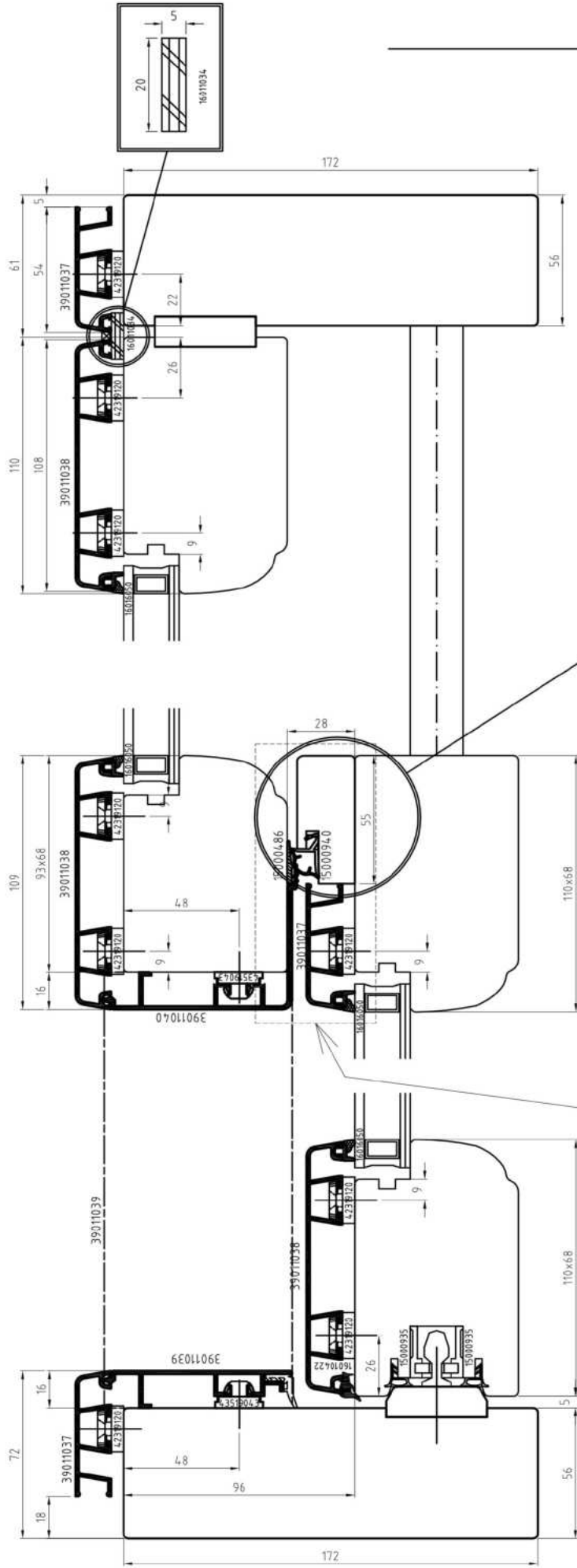

ASTRO 1 - sezioni

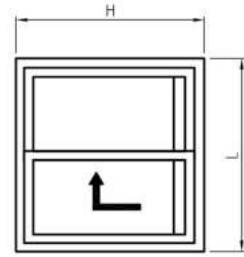

Alzante scorrevole  
anta fisso - apribile

Sistema:	ASTRO 1	Scala:	1:2.5	Revisione e data :	Tavola:
Descrizione :	SEZIONE ORIZZONTALE ALZANTE SCORREVOLE				HS310
Data emissione:	ALZ_REV.07				n° Pagina





ALZANTE SCORREVOLE ANTA APRIBILE-APRIBILE

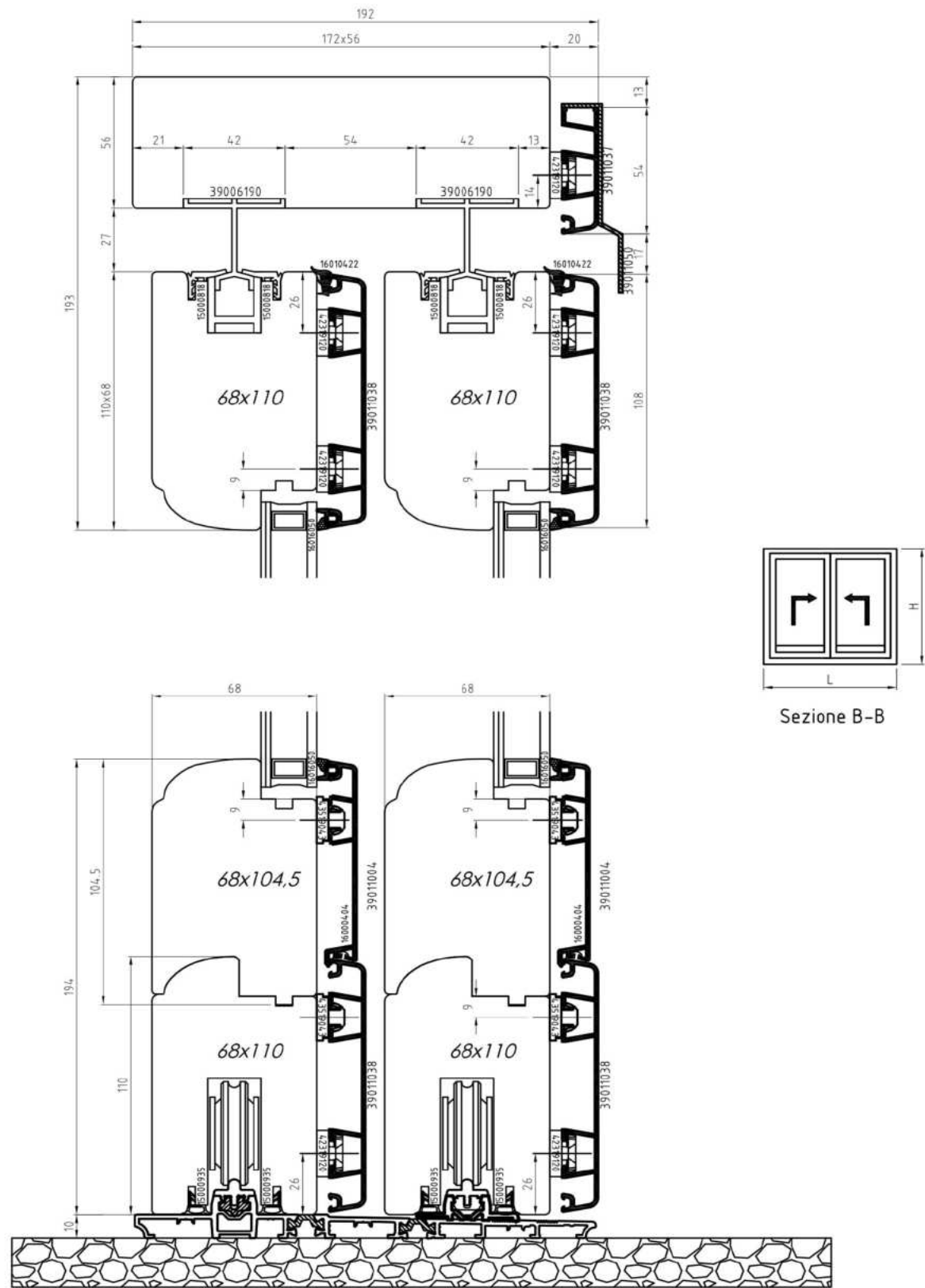

Sezione B-B



Sistema: <b>ASTRO 1</b>	Scala: <i>F.Scala</i>	Revisione e data :	Tavola: <b>HS510</b>
Descrizione : <b>SEZIONE VERTICALE ALZANTE SCORREVOLE</b>			
Data emissione:	Nome File: <b>ALZ_REV.07</b>	n° Pagina	



ALZANTE SCORREVOLE ANTA APRIBILE-APRIBILE

ASTRO 1 - sezioni

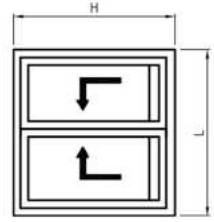
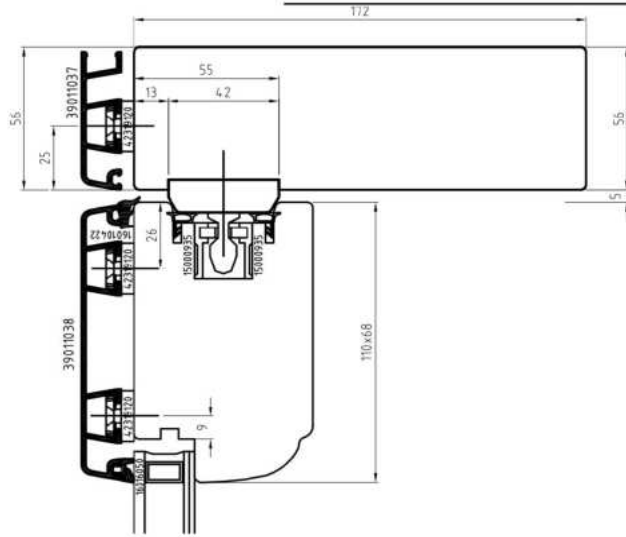
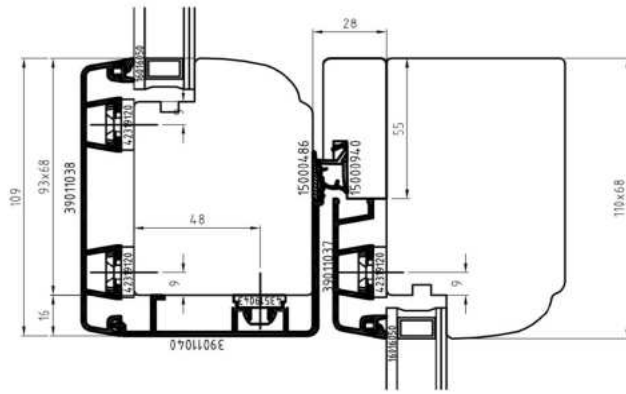
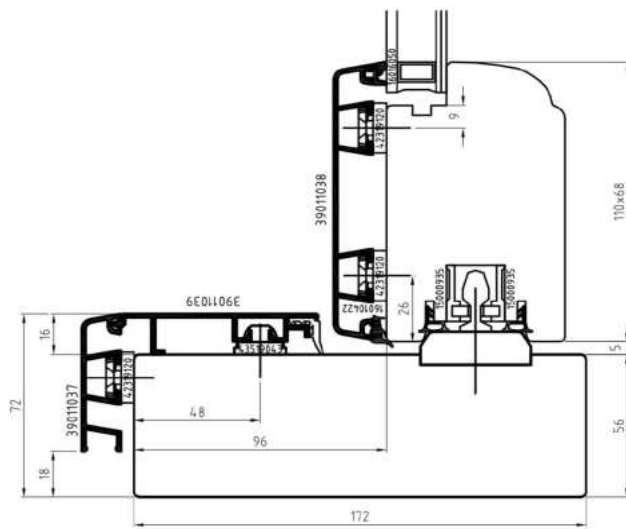

	Sistema:	ASTRO 1	Scala:	1:2.5	Revisione e data :	Tavola:	HS710
	Descrizione :	SEZIONE ORIZZONTALE ALZANTE SCORREVOLE					
	Data emissione:	08/04/2014	Name File:	ALZ_REV.07	n° Pagina		
	© Riproduzione e trasmissione vietata a terzi						

Profilo Telaio

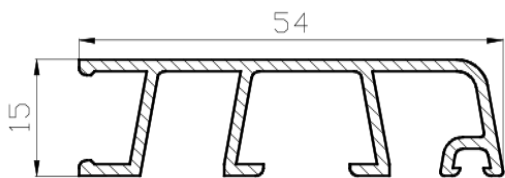

39011037

Profilo Anta

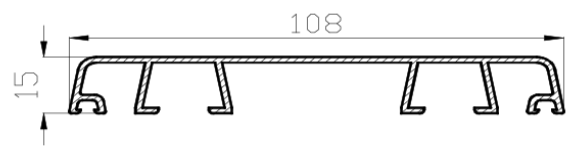

39011038

Profilo Telaio Monoclip

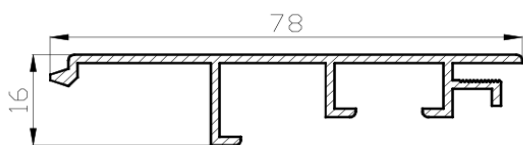

39011039

Profilo Montante centrale

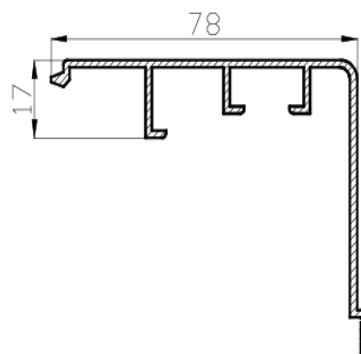

39011040



Accessori

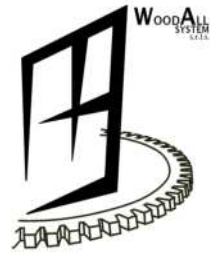

W  
O  
O  
D

SYSTEM

ALL

OLTRE  
CIO' CHE VEDI!

Squadretta bassa con viti

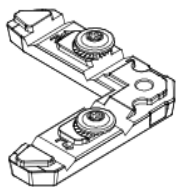

49010026,20

Squadretta con viti regolabile

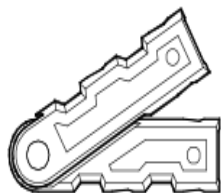

49010046,20

Squadretta a cianfrinare

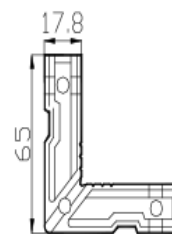

40011021,12

Squadretta di allineamento

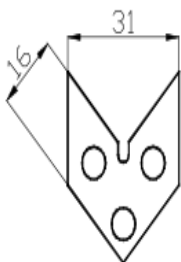

49011026,20

Terminale per profilo 16003

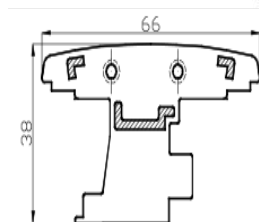

41416022,12

Terminale per profilo 16005

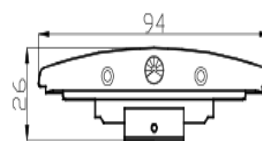

41416023,12

Squadretta sistemi astro meccanica ad avvitare

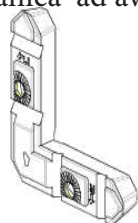

49016026,20

Clip automatica bianca sp.3mm

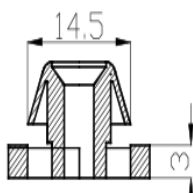

42916043,13

Squadretta allineamento astro 6

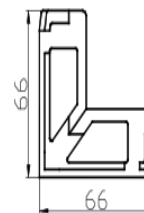

42616045,20

Squadretta di allineamento anta portoncino astro 6

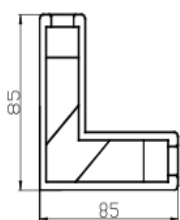

42616046,20

Squadretta di aggancio per zoccolo

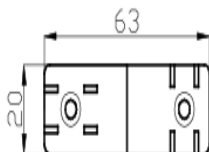

42616051,20

Dado di fissaggio filettato

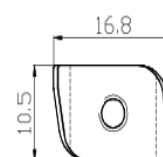

42616059,20

Terminale per profilo 16113

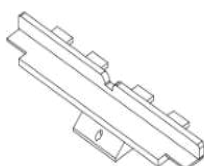

41416132,12

Squadretta di allineamento anta astro 6 diamante astro 6 quadra



49016145,20

Terminale per profilo 19003

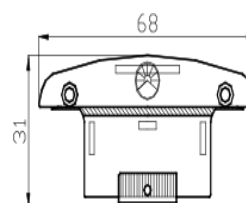

41419022,12

Terminale per profilo 19103

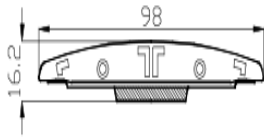

41419023,12

Clip automatica marrone sp.5mm

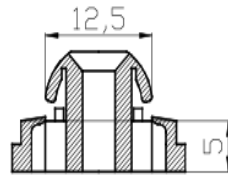

43519043,11

Clip manuale nera sp.5mm

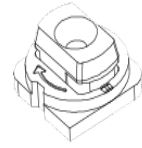

42319120,12

Guarnizioni



◀ W  
O  
O  
D

SYSTEM

ALL

OLTRE  
CIO' CHE VEDI!

Guarnizione giunto aperto

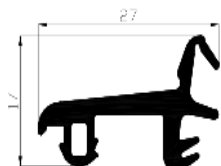

16016027.12

Guarnizione esterno vetro 3mm

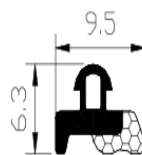

16016038.13

Guarnizione interna vetro 3mm

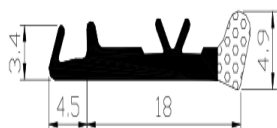

16016032.12

Guarnizione montante centrale

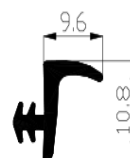

16016042.12

Guarnizione interna vetro 3mm

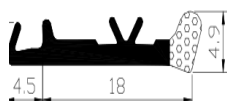

16016032.13

Angolo termosaldato per 16027 a giunto aperto

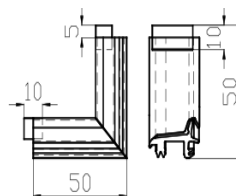

16016048.12

Guarnizione sormonto anta

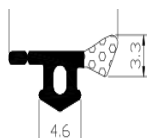

16016034.12

Guarnizione esterna vetro 5 mm

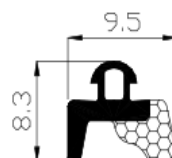

16016050.12

Guarnizione giunto aperto



16016036.12

Guarnizione tamponamento anta

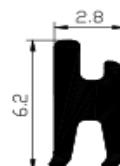

16019040.12

Guarnizione esterno vetro 3mm

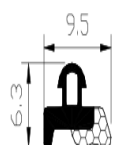

16016038.12

Angolo termosaldato per 16036 a giunto aperto

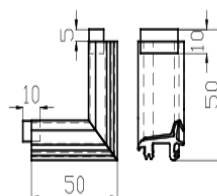

16016058.12













OLTRE  
CIO' CHE VEDI!

ZONA INDUSTRIALE UNICA CENTER  
STRADA STATALE CONSORTILE - 81032 CARINARO (CE) LOTTO 10/11  
TELEFONO: +39 0818191546  
TELEFONO MAGAZZINO: +39 3298478786