

The real 'dirt' about

“GROUND”

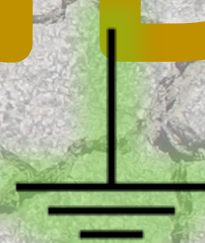

...and why you need to care

Antenna Counterpoise or Station Equipment Ground

- In this presentation I will not address antenna counterpoises in detail but what will be discussed can help to improve this part of a ham station.
- I will be addressing the station equipment ground, why it is necessary and how to do it correctly.
- A good reference, if you are a mathematician at heart, is the ARRL Antenna Book, Chapter 1 “Safety First” specifically page 1-8 “Electrical Safety”.
- The ARRL book “Grounding and Bonding for the Radio Amateur” has some very practical solutions to this issue.

What is “Ground”?

- A place to dissipate electrical surges and over-voltage conditions,
- A place to create a mirror image for your antenna,
- A place to direct dangerous lightning strikes,
- A place to grow weeds! 😊



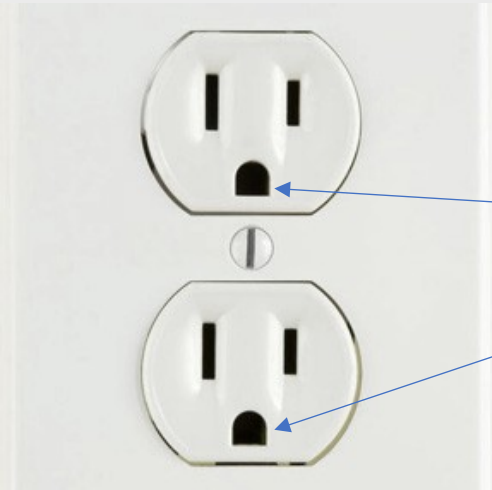

What is “Electrical” Ground?

- Electrical ground is a simple direct connection from a piece of equipment to an electrical ground system, commonly the 3rd prong on a plug or wall jack for household AC current.
- *****DO NOT USE AS AN RF GROUND!!!*****
(More about this later)
- Electrical power distribution systems are often connected to ground to limit the voltage that can appear on distribution circuits. A distribution system insulated from ground may attain a high potential due to transient voltages caused by arcing, static electricity, or accidental contact with higher potential circuits. A ground connection of the system dissipates such potentials and limits the rise in voltage of the grounded system.

Ground

An effective ground system is necessary for every amateur station. The mission of the ground system is twofold. First, it reduces the possibility of electrical shock if something in a piece of equipment should fail and the chassis or cabinet becomes "hot." If connected properly, three-wire electrical systems ground the chassis, but older amateur equipment may use the ungrounded two-wire system. A ground system to prevent shock hazards is generally referred to as "dc ground." The second job the ground system must perform is to provide a low-impedance path to ground for any stray RF current inside the station. Stray RF can cause equipment to malfunction and contributes to RFI problems. This low impedance path is usually called "**RF ground.**" In most stations, DC ground (**not the household electrical ground system!!**) and RF ground are provided by the same system.

The first step in building a ground system is to bond together the chassis of all equipment in your station. Ordinary hookup wire will do for a DC ground, but for a good RF ground you need a low-impedance conductor. Copper strap, sold as "flashing copper," is excellent for this application, but it may be hard to find. Braid from coaxial cable is a popular choice; it is readily available, makes a low-impedance conductor, and is flexible.

Grounding straps can be run from equipment chassis to equipment chassis, but a more convenient approach is illustrated in Fig 13 (next slide). In this installation, a ½-inch diameter copper water pipe runs the entire length of the operating bench. A thick braid (from discarded **RG-8** cable) runs from each piece of equipment to a clamp on the pipe. Copper water pipe is available at most hardware stores and home centers. Alternatively, a strip of flashing copper may be run along the rear of the operating bench.

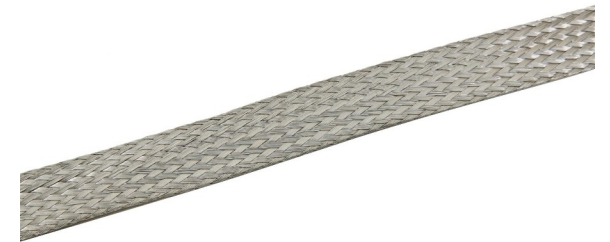

[DX Engineering DXE-TC
B-050 - DX Engineering
Tinned Copper Braid](http://www.dxengineering.com)

**\$0.60 per ft. at
www.dxengineering.com**

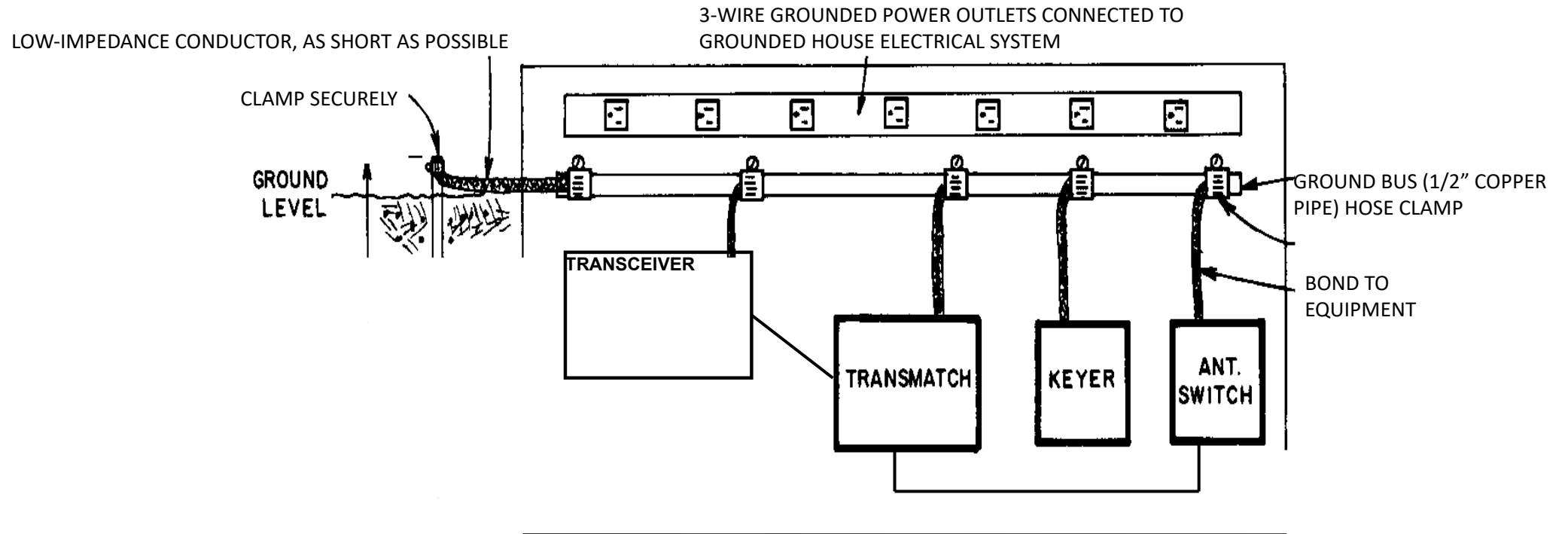

Fig 13-An effective station ground bonds the chassis of all equipment together with low-impedance conductors and ties into a good earth ground

After the equipment is bonded to a common ground bus, the ground bus must be wired to a good earth ground. This run should be made with a heavy conductor (braid is a popular choice, again) and should be as short and direct as possible. The earth ground usually takes one of two forms.

1. In most cases, the best approach is to drive one or more ground rods into the earth at the point where the conductor from the station ground bus leaves the house. The best ground rods to use are those available from an electrical supply house. These rods are 8 to 10 feet long and are made from steel with a heavy copper plating. Do not depend on shorter, thinly plated rods sold by some home electronics suppliers. These rods begin to rust almost immediately after they are driven into the soil, and they become worthless within a short time. Good ground rods, while more expensive initially, offer long-term protection.

If your soil is soft and contains few rocks, an acceptable alternative to "genuine" ground rods is ½-inch diameter copper water pipe. A 6- to 8-foot length of this material offers a good ground, but it may bend while being driven into the earth.

Once the ground rod is installed, clamp the conductor from the station ground bus to it with a clamp that can be tightened securely and will not rust. Copper-plated clamps made especially for this purpose are available from electrical supply houses, but a stainless-steel hose clamp will work too.

Electrical Safety from *The Antenna Book*, pp. 1-8 to 1-16 Copyright © 1997-1998 by the American Radio Relay League, Inc. All rights reserved



ERITECH 1/2 in. x 8 ft. Copper
Ground Rod

Model# 611380UPC

★★★★★ (7)

\$11⁹⁵

2. An ideal signal ground maintains a **fixed potential** (zero) regardless of how much electric current flows into ground or out of ground. Low impedance at the signal frequency of the electrode-to-earth connection determines its quality, and that quality is improved by;

- increasing the surface area of the electrode in contact with the earth,
- increasing the depth to which it is driven,
- using several connected ground rods,
- increasing the moisture content of the soil,
- improving the conductive mineral content of the soil, and
- increasing the land area covered by the ground system.



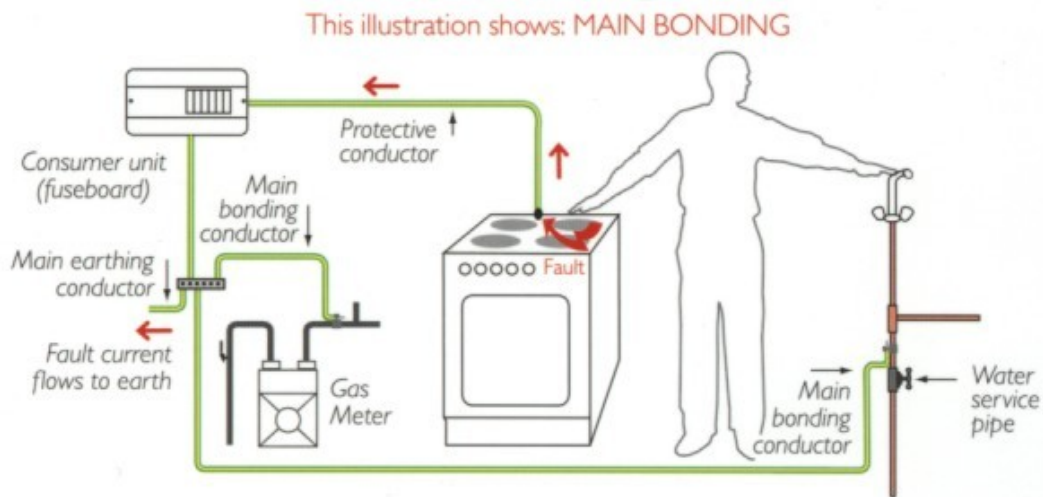

- *Equipment bonding conductors* provide a low impedance path between normally non-current-carrying metallic parts of equipment and one of the conductors of that electrical system's source. If any exposed metal part should become energized (fault), such as by a frayed or damaged conductor, it creates a short circuit, causing the overprotection device (circuit breaker or fuse) to open, clearing (disconnecting) the fault. It is important to note this action occurs regardless of whether there is a connection to the physical ground (earth); the earth itself has no role in this fault-clearing process since current must return to its source; however, the sources are very frequently connected to the physical ground (earth). By bonding (interconnecting) all exposed non-current carrying metal objects together and to other metallic objects such as pipes or structural steel, they should remain near the same voltage potential, thus reducing the chance of a shock. This is especially important in bathrooms where one may be in contact with several different metallic systems such as supply and drain pipes and appliance frames. When a system needs to be connected to the physical ground (earth), the equipment bonding conductor also becomes the equipment earthing conductor (see above).



- A **grounding electrode conductor (GEC)** is used to connect the system grounded ("neutral") conductor, or the equipment to a grounding electrode, or a point on the grounding electrode system. This is called "system grounding" and most electrical systems are required to be grounded. The U.S. NEC and the UK's BS 7671 list systems that are required to be grounded. According to the NEC, the purpose of connecting an electrical system to the physical ground (earth) is to limit the voltage imposed by lightning events and contact with higher voltage lines, and also for voltage stabilization. In the past, water supply pipes were used as grounding electrodes, but due to the increased use of plastic pipes, which are poor conductors, the use of an actual grounding electrode is required. **This type of ground applies to radio antennas** and to lightning protection systems.

- Permanently installed electrical equipment, unless not required to, must have permanently connected grounding conductors. Portable electrical devices with metal cases may have them connected to earth ground by a pin on the attachment plug. The size of power grounding conductors is usually regulated by local or national wiring regulations.
- **It is a good idea to be familiar with the NEC when planning your station grounding system.**

National Electric Code Article 250 – Grounding

[Jon Workman](http://www.acmetools.com/blog/national-electric-code-article-250-grounding/) / October 6, 2016 <http://www.acmetools.com/blog/national-electric-code-article-250-grounding/>

You get reminders every day. Reminders on your phone, reminders in your email, reminders in your texts. Some reminders get kind of annoying, but some reminders are there to keep you safe. If you haven't read article 250.4 – Grounding in the National Electrical Code lately, then consider this a reminder.

According to the US Department of Labor, "Accident statistics compiled by MSHA's Health Safety Analysis Center indicate that approximately 14% of all electrical fatalities occur from improper or inadequate grounding." Grounding and bonding might sound like simple concepts, especially to a journeyman or a master electrician, and it really is SIMPLE, but that doesn't always mean it's easy. There may even be times when you wonder if something needs to be grounded at all. Do you really need to ground everything? During my electrical apprenticeship, one Master that I worked under told me not to land the ground wires on the switches when we would wire houses. "It's too much hassle, the boxes are too tight, and the ground wire always ends up touching one of the hots, so just don't worry about it. No one ever gets hurt anyway....." Really?

Article 250 – Grounding

Article 250 of the National Electrical Code covers grounding and bonding in great detail, and with all that detail, it can be easy to get lost or confused and forget that the code is there to help you accomplish something. That something is to keep those who use the electrical equipment safe and to protect property from electrical hazards. Let's cover a sub-section that is especially important to keeping clients and loved ones safe.

"250.4(A)(3) Bonding of Electrical Equipment. Normally Non-current carrying conductive materials enclosing electrical conductors or equipment or forming part of such equipment should be connected together and to the electrical supply source in a manner that establishes an effective ground-fault current path."

Let's break this down....

Enclosures

What are “Normally Non-current carrying conductive materials enclosing electrical conductors”? That’s a fancy way of saying, “materials that you would pull wire (conductors) through (enclosing them) that have the ability to conduct electricity, but that you don’t want to use to conduct electricity. Typically this is something made of some type of metal, like conduit, or cable tray, or maybe even unistrut. You use these items as raceways, but not conductors.

Equipment Parts

How about Normally non-current carrying “equipment or forming part of such equipment”? That might cover items like panelboard enclosures and covers, light fixture housings, a motor housing, and even the metal piece on a switch or your HF rig’s chassis. This article continues to tell us that “equipment should be connected together and to the electrical supply source in a manner that establishes an effective ground-fault current path.” An effective ground-fault current path is absolutely critical and this article reminds us that everything that is metallic, and contains conductors, whether it be wire or bussing, must be connected together (bonded) and be connected to the source, whether it be a transformer, generator, or photovoltaic system, providing an uninterrupted path to ground for any faults that might occur.

Potential Tragedy

Think of what would happen if you have a piece of conduit or an enclosure that isn't bonded to the rest of the grounding system, and it's not going to ground anywhere else. Let's say a ground fault occurs in that enclosure or piece of pipe. Nothing would happen at first because, remember, it's not going to ground anywhere. You're essentially just adding length to the conductor. But when someone comes up and touches that piece of metal, they become the ground path, and they won't enjoy what happens.... **If they live through it.**

How to visualize proper bonding

If you struggle to understand what proper bonding is, then here's a way to help you visualize how it would look. Set your multimeter to the continuity setting. Now, imagine taking one lead and touching any metal component of one circuit. It could be a four square box, enclosure, conduit, locknut, appliance frame, etc. Now take the other lead anywhere in the building (yes, it would have to be extremely long). Touch another metal component used either in the same or different circuit. If you have bonded properly, the tester would show continuity between the two metal pieces you're touching with your meter probes. All of the metal components have basically become "one unit." That's the reason every connection in a circuit is critical. This ground-fault path goes through conduits, locknuts, wiring, light fixture bodies, pull boxes, etc. It only takes one loose screw in a terminal bar or a loose locknut or wire nut to break a link in the fault current chain leaving the fault current to find a new path to ground.

RF Ground

- RF “ground” or ‘station ground’ is a path for RF to return to the feed point, although it can be the same potential as a DC ground. Think of ALL antennas as a form of dipole, it needs a good mirror image to operate efficiently. An RF ground can be at any elevation and does not necessarily need to be at DC ground. [How do antennas work on the ISS?](#)

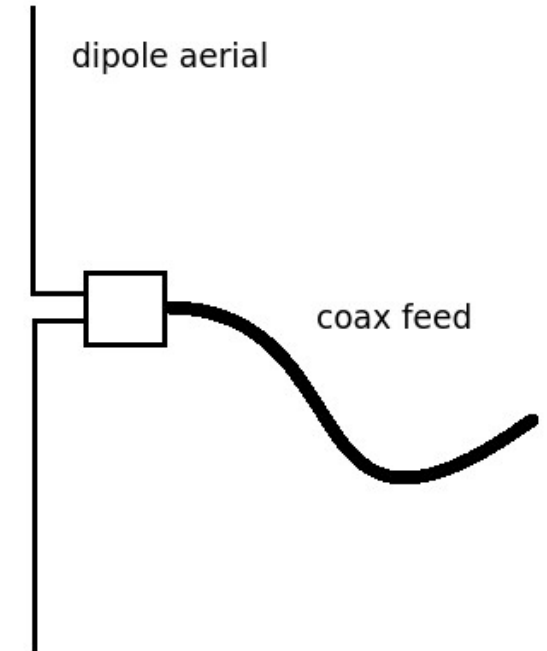
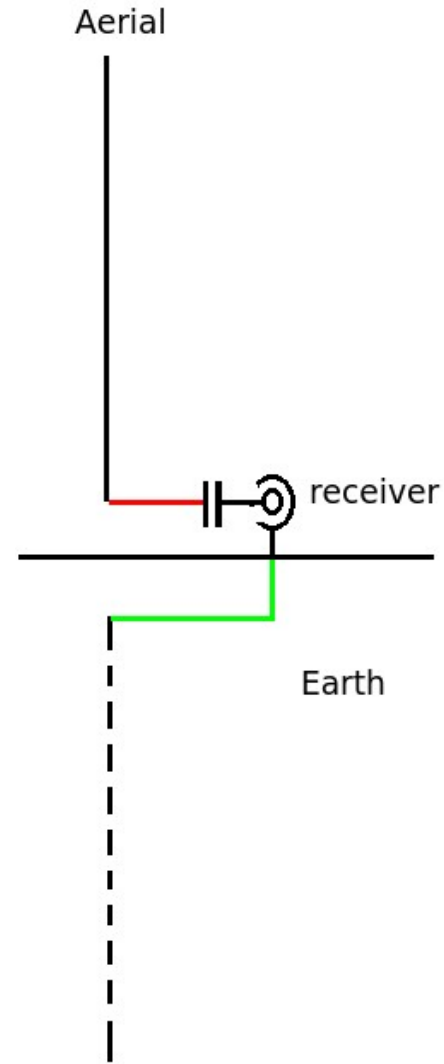

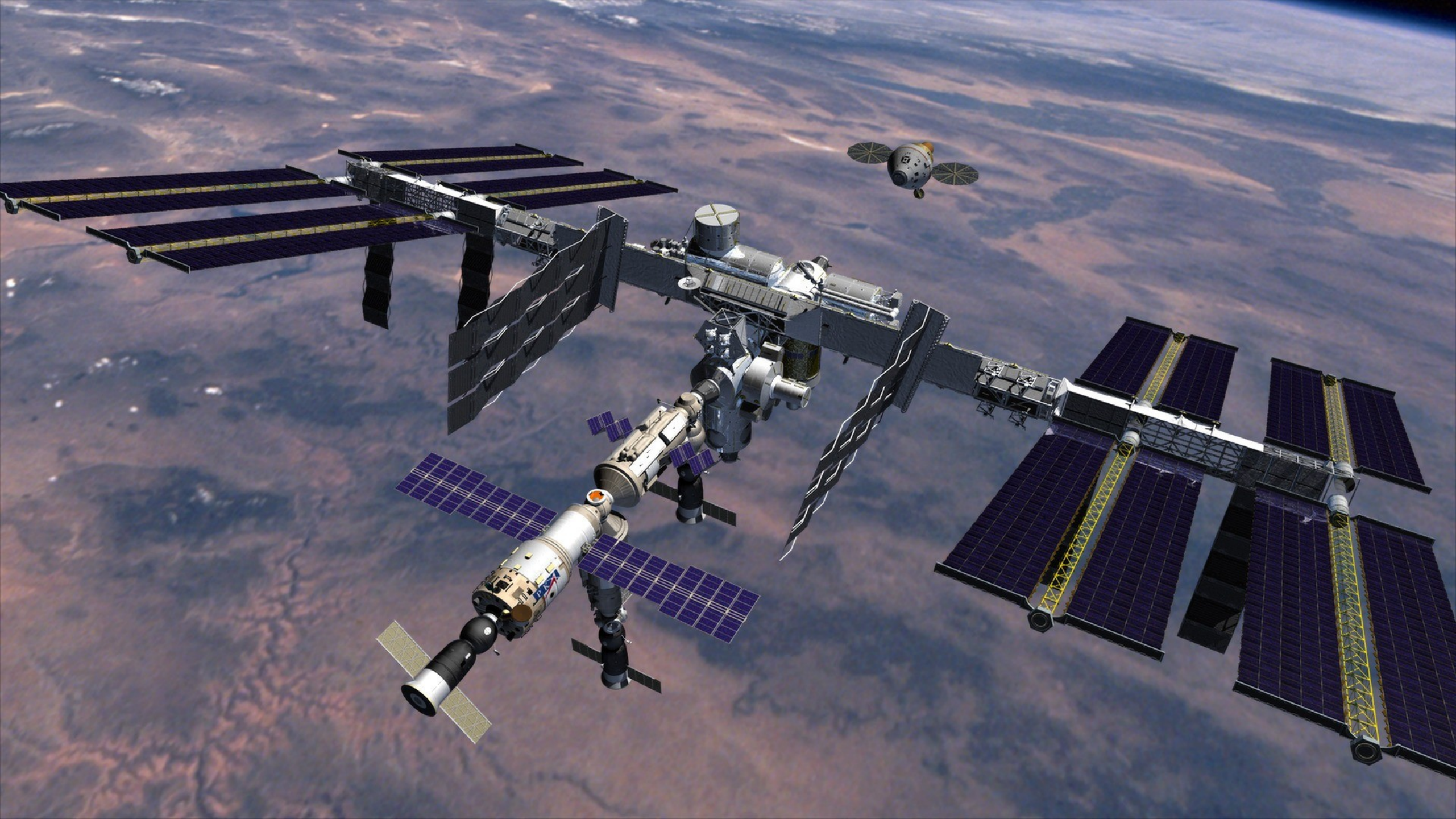

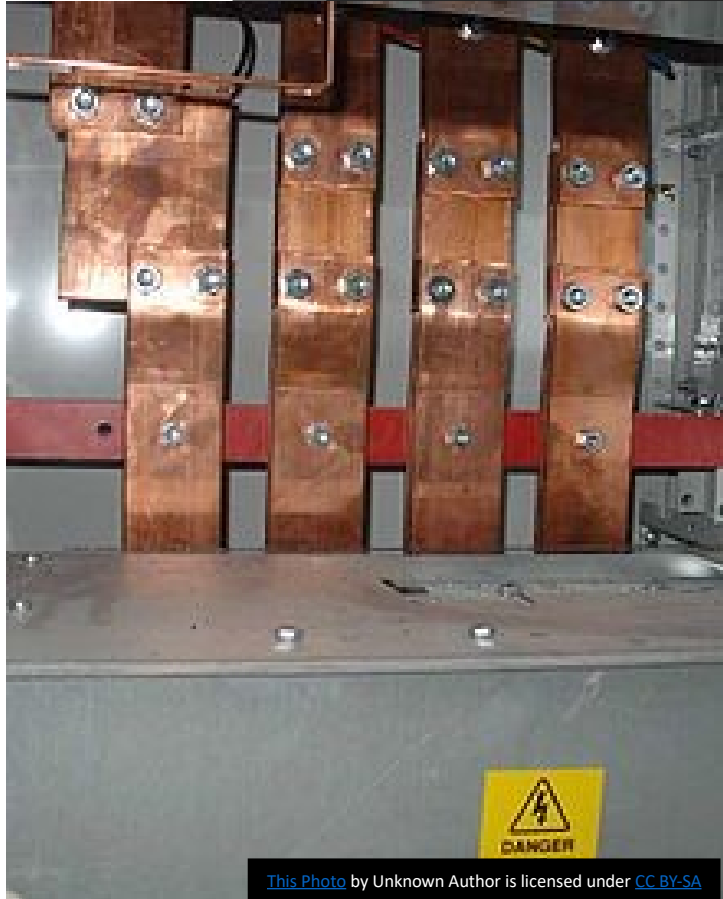

[This Photo](#) by Unknown Author is licensed under [CC BY-SA](#)

- An electrical connection to earth can be used as a reference potential for radio frequency signals for certain kinds of antennas. The part directly in contact with the earth - the "earth electrode" - can be as simple as a metal rod or stake driven into the earth, or a connection to buried metal water piping (the pipe must be conductive). Because high frequency signals can flow to earth due to capacitive effects, capacitance to ground is an important factor in effectiveness of signal grounds. Because of this, a complex system of buried rods and wires can be effective.

Ground Loops (and the worst case scenario)

Ground loops are a major concern and worry to be dealt with as you lay out an RF ground system! Lets lay out a worst possible case scenario of what would be a terrible way to ground a 20 meter (and all harmonically related bands) home station.

Lets say that our 20 meter Ham has his "Ham Shack" in approximately the middle of his house, up on the second floor. He uses a nice low resistance and low inductance flat braided strap (lets let him do at least one thing right), which runs from his 1500 Watt amplifier to **a 2 foot deep ground rod in his front yard**. This braided conductor runs between the floor of the second story and the ceiling of the lower story. It then runs down the outside of his **stucco covered home** to the ground rod. Its **total length is 33 feet** long from the amplifier to the ground rod.

Fifty feet (15.24 meters) of coaxial cable goes up between the walls of the second story, is draped over to the top of his tower, and terminates at his TH6DXX beam on this 65 foot tall tower. Does his beam have any effect on his transmitted signal?

Analysis

Our rueful Ham friend is using a ground conductor that is almost exactly **one half wavelength** long and is raised in the air by the buildings structure. Even if this length were reduced to about a quarter wavelength, it would still very nicely couple energy into other wiring in the house, and the wire mesh beneath the stucco walls. This other wiring could be telephone wires, television cabling, and the 110 volt power wiring in the house. His coax cable's shield is a nice "**odd order harmonic**" radiator, as it is $3/4$ wavelength long! The ungrounded tower is about a half wavelength tall.

This last point about the tower must be viewed carefully. He might want to ground it as an RF consideration, and he might not! Think about it this way. One ground rod is in the front yard at the end of a half wavelength wire. The shield of the coax cable ultimately goes to ground in the back yard at the tower base at an electrical length of about 7 quarter wavelengths ($50 + 65 = 115$ feet). This makes another sort of odd order harmonic radiator! If you add into this loop circuit the length of the front yard ground rod conductor, the loop circumference becomes 9 quarter wavelengths. **Yet another odd order radiator dimension!**

My assessment of this Ham's station would inform me that he is throwing away some of the advantage of his beam and the height of his tower because, all of the radiating conductors strung around the house raise the "**angle of radiation**" considerably higher than it could otherwise be! He is also enhancing the prospects of "**audio rectification**" to his own and to neighbors telephones. He is also enhancing the possibility of "**TVI**" to his television, and maybe to the neighbors as well if they all use a cable TV system.

The Absolute Worst Thing To Do

Maybe though this isn't the worst case scenario? The worst case would be the Ham that tries to use the 3rd wire ground within the 110 volt AC power system that runs through his house. Then he could really couple RF energy around his house and the neighborhood!

!!!!Never ever use this third wire ground as an RF ground!!!!

How Should our Ham have done it

- 1)** His station should be on the **ground floor** of the house.
- 2)** His low inductance low resistance grounding conductor should have considerably less than a quarter wavelength of total length between his amplifier and the first ground rod.
- 3)** If the soil or other conditions in his yard allowed only short length rods, **he should have used several of them** all tied to a common point, and ultimately connected to a "**grounding cage**" or rods near the **outside** of the tower's concrete base.

Important Tip: Don't install the ground cage within the concrete! One reason is that it is connected to the earth via the high resistance of the concrete. The other reason is that a lightning strike to the tower may well blow the concrete block to bits!

When Should an RF Ground Be Used and When is it a Bad Thing

With the advent of the many new MF/HF/VHF transceivers on the market these days, Hams are flocking to frequency bands on which they have little or no experience. Additionally because of the licensing structure, one of the most popular Ham bands in use is the 10 Meter band (This was written in the late 70's.

Propagation has changed this to be the 2 meter band). I'm sure also that within the coming years, 6 Meters will become even more popular. On 6 meters at least, RFI is very simply controlled.

On one of these two mentioned bands, and also on most bands above 20 Meters, television interference from harmonic radiation becomes a concern that grounding will not fix. In fact most practical possibilities for grounding systems at a typical residential home, will enhance this TVI (Television Interference) problem!

On lower frequency bands, both RF noise level, and also "**ground wave**" signal propagation become an important concern. Just to give you a clue, AM broadcast stations invest huge amounts of money in designing and installing their antenna grounding systems. Of course, we are nearby neighbors, almost kissing cousins you might say of the Broadcast band that ends just below 160 meters! On this band doing everything you can to enhance the signal is preeminent within the stations design. It even becomes easier to install a good grounding system than it is to install good antennas!

Think about it. Even if you could put an antenna that is 260 feet long, 100 feet above the ground, it would still be only .19 wavelengths above the ground. That would be the equivalent of installing a 2 meter antenna at about 15.6 inches above the ground!

Think about it this way, the second harmonic of the 28 MHz. band falls right at TV channel 2 ($2 \times 28 = 56$ MHz.)! This is the fourth harmonic of the 20 Meter band ($4 \times 14 = 56$ MHz.)! From this description and the other worst case scenarios that I outlined, you may be thinking, so is he saying not to bother with installing a ground system? Well, that's not at all what I'm saying! I am telling you though that you must appreciate and design your grounding system so that it cannot possibly contribute to either "**fundamental frequency**" radiation, and also not contribute to the re-radiation of harmonics of these upper HF bands.

The prime methods for accomplishing this are to;

- (1) keep the ground conductor shorter than a quarter wavelength on 10 Meters, which is of course the highest frequency HF band.
- (2) Next, we must make this conductor be at the lowest AC resistance (impedance) possible! We do this by using large surface area (fat) conductors, and **SOLDER** all connections. After soldering, seal them from the eroding effects of weather by using electricians tape and silicon sealers. Anti-oxidizing compounds such as "No-Ox", which are available at most electrical suppliers, are a must for any connection of dissimilar metals! A simpler way to deal with this last mentioned concern is to simply use non-alloy baring copper for the entire system. Copper tubing typically used for plumbing meets all of the above requirements perfectly. Don't use steel or iron pipe for ground rods!.
- (3) Always connect multiple ground rods in a line. This line can bend or zigzag but, it must extend from the nearest to the furthest ground rod or screen in a line.
- (4) The last physical consideration is to cover as much ground surface area as is practical within the constraints of your yard or acreage. A minimum RF ground system will use at least three 8 foot or longer ground rods. If you can't sink a rod that long, than you must use many more shorter rods, or bury a splayed out radial system of wires. In this last case you must terminate this wire radial screen within less than a quarter wavelength at 29.7 MHz. (which is 94.5 inches or 2.4 meters). Thinking conversely, if a grounding system becomes a touchy prospect at the higher bands, might it be a better consideration and benefit at the lower bands such as 160 meters? If you answered this question absolutely, you win a gold star, and Ham of the year award!

Single point ground strategy

- Typical Station

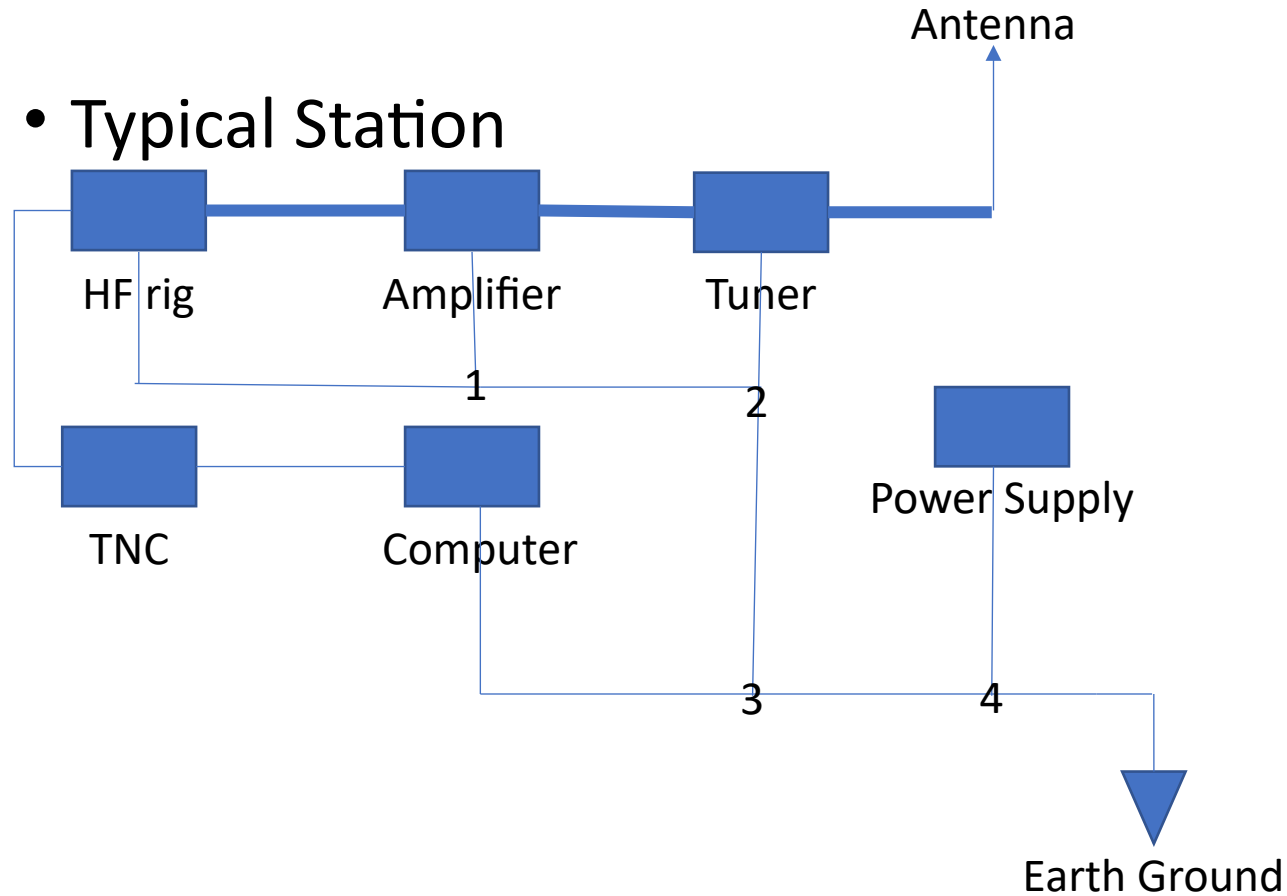

“Ground Loops; HF Rig to Amp, Amp to Tuner and others”.

ALL wire has **resistance**.

ALL wire has **capacitance**.

ALL wire has **inductance**.

Ground loops can use these properties to create resonant circuits within the ground system.

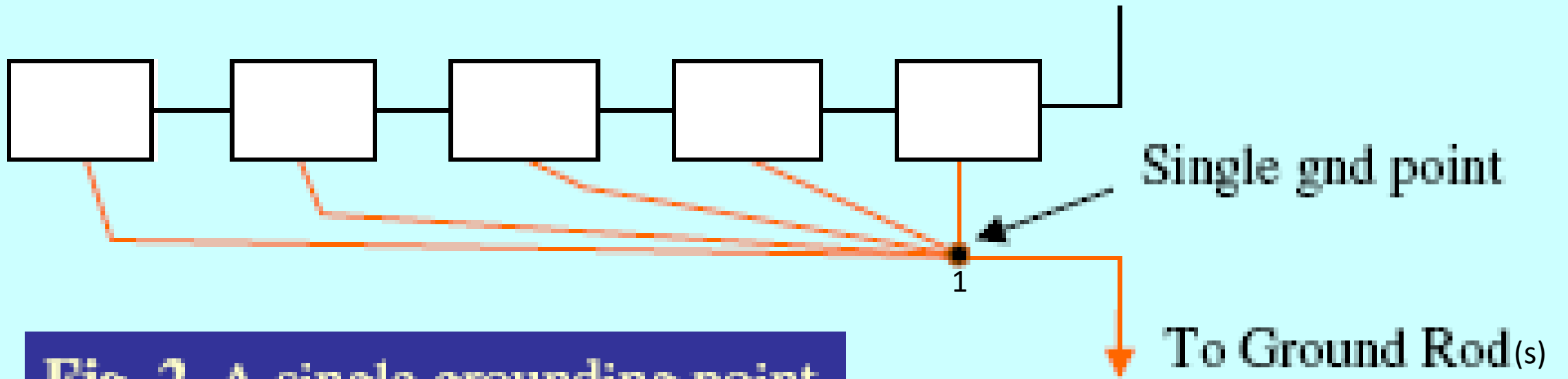
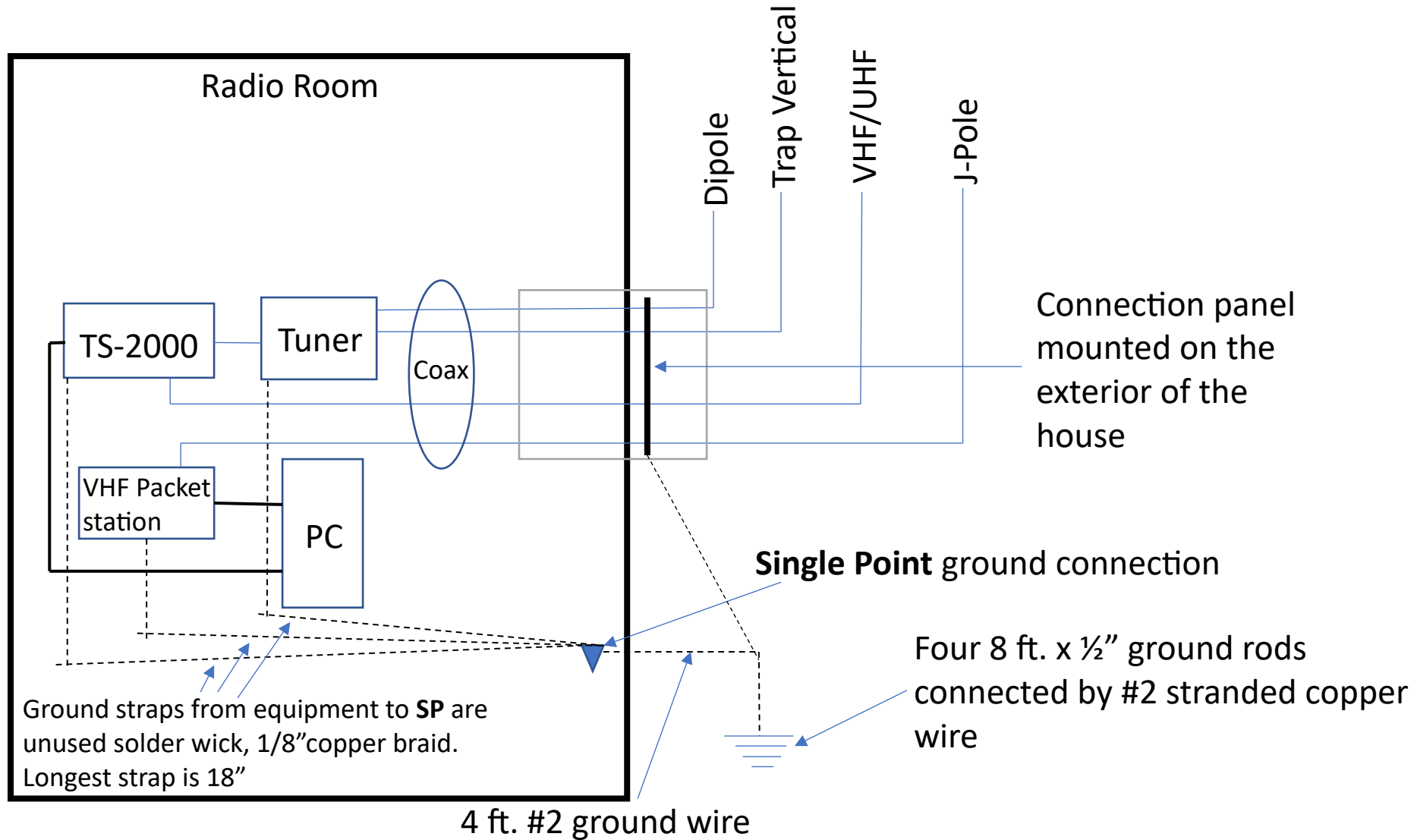

Fig. 2. A single grounding point to prevent ground loops

A single-point ground system tends to neutralize the effects of R, C, and L in ground loops.

My Station Ground W7PLC





Sawhorse to hold and align ground rods



Ground wire from shack

Ran into rock shelf at 6.5 ft. so this is the finished project. Dug a 1 ft. hole and filled it with water 4 times to “soak” the rods. Tested in the shack and no more RF problems. Cage is temporary, kids were playing in the yard next-door. I planted a bush in the center of the rods to hide them, wife was pleased.



As you can see from my experience, no installation is perfect. The only place a “perfect ground” exists is in theory.

That being said, we can simply do what we can with what we have.

Don't make the mistakes I made when I installed my first ground system. As it turned out, my previous ground system was nothing more than a multi-band antenna laying on the ground. This new one is a vast improvement but is far from perfect.



- Check all your grounding and improve where needed.
- Questions?
- On the web:
 - http://www.w8ji.com/house_ground_layouts.htm
 - <http://www.arrl.org/grounding>
 - <http://www.bwcelectronics.com/articles/WP30A190.pdf>
 - <https://helpdesk.flexradio.com/hc/en-us/articles/204779159-Grounding-Systems-in-the-Ham-Shack-Paradigms-Facts-and-Fallacies>

