

SP-41-00

# FIS GAS SENSOR SP-41-00

## for REFRIGERANT DETECTION: HCFCs (R-22)

The SP-41 is a tin di-oxide semiconductor gas sensor which has a high sensitivity to HCFCs (e.g. Freon: R-22) with reduced sensitivity to other gases such as alcohol.

### Structure

Gas sensitive semiconductor material is formed on the alumina substrate on which the gold electrodes are printed. A thick film heater of ruthenium oxide is printed on the reverse of the substrate and placed in the plastic housing (Fig 1).

### Operating conditions

Fig 2 shows the standard operating circuit for this model. The change of the sensor resistance ( $R_S$ ) is obtained as the change of the output voltage across the fixed or variable resistor ( $R_L$ ). In order to obtain the best performance and specified characteristics, the values of the heater voltage ( $V_H$ ) circuit voltage ( $V_C$ ) and load resistance ( $R_L$ ) must be within the range of values given in the standard operating conditions shown in the Specification table on the next page.

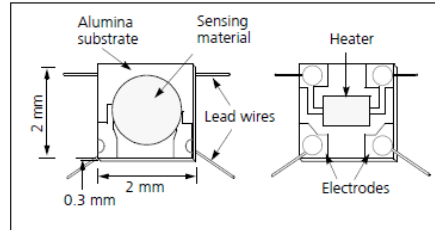

Fig 1a. Sensing element

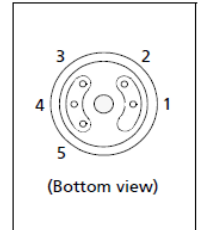

Fig 1c. Pin Layout

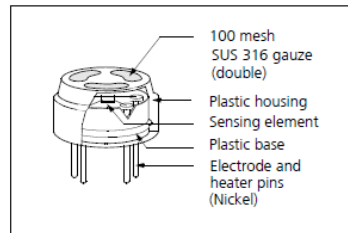

Fig 1b. Configuration

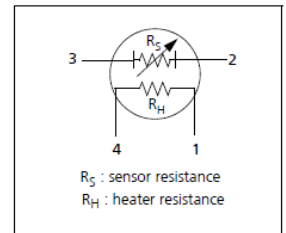

Fig 1d. Equivalent circuit

### Sensitivity characteristics

Fig 3 shows the sensitivity characteristics curves of the SP-41 (typical data). Sensitivity characteristics of our gas sensors are expressed by the relationship between the sensor resistance and gas concentration. The sensor resistance decreases with an increase of gas concentration based on a logarithmic function.

The sensitivity characteristics of the SP-41 is specified by the following parameters.

- Sensor resistance level: at R-22 1000 ppm
- Sensor resistance change ratio: between R-22 1000ppm and 3000 ppm

See the specification table on the next page for further details.

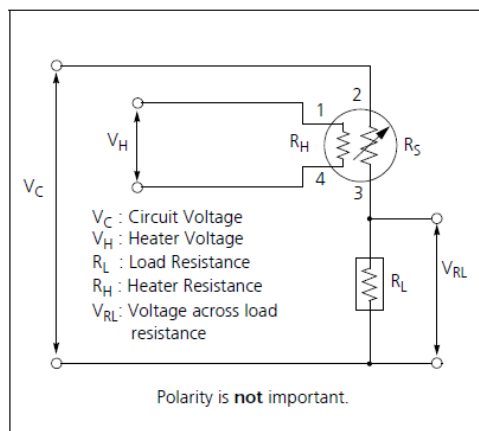

Fig 2. Standard circuit

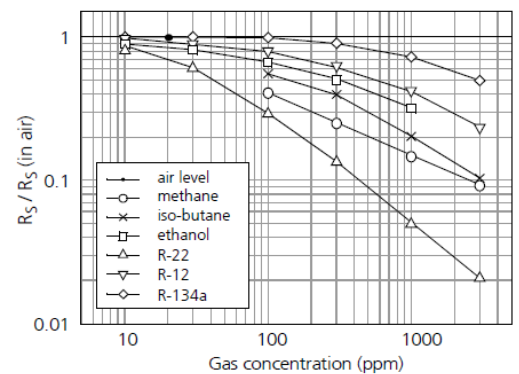

Fig3. Sensitivity characteristics

# Specifications: SP-41-00

## A. Standard Operating conditions

Symbol	Parameter	Specification	Conditions etc.
VH	Heater voltage	5.0 V ± 4%	AC or DC
VC	Circuit voltage	5.0 V ± 4%	AC or DC
RL	Load resistance	Variable	P <sub>s</sub> < 15 mW
RH	Heater resistance	56Ω ± 2Ω	at room temperature
IH	Heater current	63 mA (Typical value)	IH = VH / RH
PH	Heater power consumption	315 mW (Typical value)	PH = VH <sup>2</sup> / RH
PS	Power dissipation of sensing element	Less than 15 mW	$P_s = \frac{(V_C - V_{RL})^2}{R}$

## B. Environmental conditions

Symbol	Parameter	Specification	Conditions etc.
T <sub>ao</sub>	Operating temperature	-10 °C to 50 °C	
T <sub>as</sub>	Storage temp	-20 °C to 60 °C	
RH	Relative humidity	Less than 95%RH	
(O <sub>2</sub> )	Oxygen concentration	21% ± 1% (Standard condition)  The sensitivity characteristics are influenced by the variation in oxygen concentration. Please consult us for details.	Absolute minimum level : more than 18%.

## C. Sensitivity characteristics

Model	SP-41-00		
Symbol	Parameter	Specification	Conditions etc.
R <sub>s</sub>	Sensor resistance	1k to 10kΩ	at R-22 of 1000 ppm
β	Sensitivity slope	0.25 to 0.55	$\frac{R_s \text{ at 3000 ppm of R-22}}{R_s \text{ at 1000 ppm of R-22}}$
Standard Test Conditions:		Temp: 20 °C ± 2 °C Humidity: 65% ± 5% (in clean air) Pre-heating time: more than 48 hours	VC: 5.0V ± 1% VH: 5.0V ± 1% RH: 10.0 kΩ ± 5%

## D. Mechanical characteristics

Items	Conditions	Specifications
Vibration	Frequency: 100cpm Vertical amplitude: 4mm Duration: 1hour	Should satisfy the specifications shown in the sensitivity characteristics after test.
Drop	Acceleration: 100 G Number of impacts: 5 times	

## Dimensions

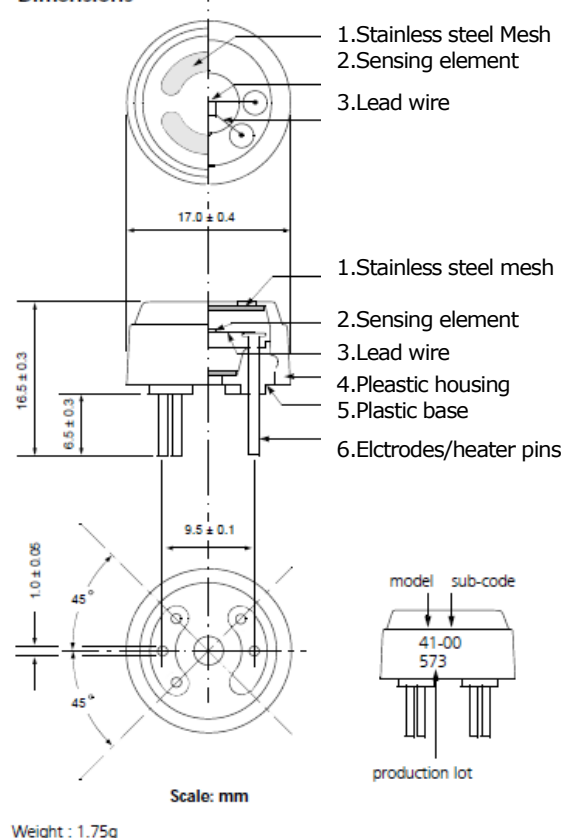

## E. Parts and Materials

No.	Parts	Materials
1	Stainless steel mesh	SUS 316 (100 mesh, double)
2	Sensing element	Tin dioxide (SnO <sub>2</sub> )
3	Lead wire	Gold alloy (Au-Pd-Mo)
4	Plastic housing	Nylon 46 (UL94HB)
5	Plastic base	Nylon 66 (UL94HB)
6	Heater/electrode pins	Nickel

Please contact

Dec. 2021 Revised

Nissha FIS, Inc.  
2-4-28, Tagawa  
Yodogawa, Osaka  
532-0027 Japan

Tel: +81 6-7176-3911  
Fax: +81 6-7176-3912  
<http://www.fisinc.co.jp>

In the interest of continued product improvement, we reserve the right to change design features without prior notice.

@nissha