



basic education

Department:
Basic Education
REPUBLIC OF SOUTH AFRICA

NATIONAL SENIOR CERTIFICATE

GRADE 12

PHYSICAL SCIENCES: PHYSICS (P1)

NOVEMBER 2022

MARKS: 150

TIME: 3 hours

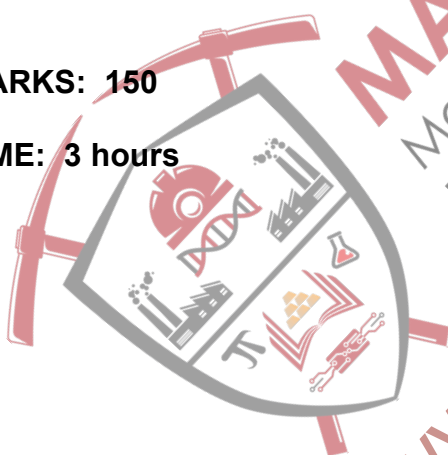

This question paper consists of 18 pages and 3 data sheets.

INSTRUCTIONS AND INFORMATION

1. Write your centre number and examination number in the appropriate spaces on the ANSWER BOOK.
2. This question paper consists of 10 questions. Answer ALL the questions in the ANSWER BOOK.
3. Start EACH question on a NEW page in the ANSWER BOOK.
4. Number the answers correctly according to the numbering system used in this question paper.
5. Leave ONE line between two subquestions, e.g. between QUESTION 2.1 and QUESTION 2.2.
6. You may use a non-programmable calculator.
7. You may use appropriate mathematical instruments.
8. Show ALL formulae and substitutions in ALL calculations.
9. Round off your FINAL numerical answers to a minimum of TWO decimal places.
10. Give brief motivations, discussions, etc. where required.
11. You are advised to use the attached DATA SHEETS.
12. Write neatly and legibly.



MANDISA SHICEKASOS
Maths, Science & ICT
Focus: Mining & Manufacturing

www.mandisashicekasos.com

QUESTION 1: MULTIPLE-CHOICE QUESTIONS

Various options are provided as possible answers to the following questions. Each question has only ONE correct answer. Choose the answer and write only the letter (A–D) next to the question numbers (1.1 to 1.10) in the ANSWER BOOK, e.g. 1.11 E.

- 1.1 Which ONE of the following combinations consists of only SCALAR quantities?
- A Velocity, speed and time
- B Time, distance and speed
- C Acceleration, speed and distance
- D Displacement, velocity and acceleration (2)

- 1.2 The acceleration due to gravity on Earth is g .
- Which ONE of the following represents the acceleration due to gravity on a planet that has TWICE the mass and HALF the radius of the Earth?
- A $-g$
- B $2g$
- C $4g$
- D $8g$ (2)

- 1.3 A ball is projected vertically upwards from the ground and reaches its maximum height after a while.
- Ignore the effects of air friction.

How will the ACCELERATION and TOTAL MECHANICAL ENERGY of the ball at its maximum height compare to that immediately after it was projected?

	ACCELERATION	TOTAL MECHANICAL ENERGY
A	Equal to	Equal to
B	Greater than	Smaller than
C	Equal to	Greater than
D	Smaller than	Equal to

(2)

- 1.4 A car travels at **CONSTANT VELOCITY** along a horizontal road. A constant frictional force acts on the car during its motion.

Which **ONE** of the following statements about the power dissipated by the engine of the car during the motion is **CORRECT**?

The power ...

- A is zero.
- B increases.
- C decreases.
- D remains constant.

(2)

- 1.5 Block X is placed on a horizontal table and is connected to block Y by a light inextensible string passing over a frictionless pulley, as shown below.

A constant frictional force acts on block X while it moves to the right.

P, **Q** and **R** are points on the table such that the distance from **P** to **Q** is equal to that from **Q** to **R**.

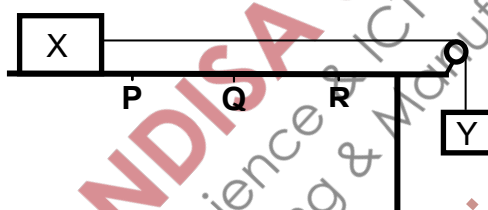

When block X reaches point **Q**, the string is cut and block X continues to move towards point **R**. Ignore the effect of air friction.

Consider the following statements:

- (i) The work done by the frictional force acting on block X is greater when the block moves from point **P** to point **Q** than when the block moves from point **Q** to point **R**.
- (ii) Both the momentum and kinetic energy of block X decrease when the block moves from point **Q** to point **R**.
- (iii) The total mechanical energy of block X remains constant when the block moves from point **Q** to point **R**.

Which of the statements above is/are **CORRECT** as block X moves from point **Q** to point **R**?

- A (i) only
- B (ii) only
- C (i) and (ii) only
- D (ii) and (iii) only

(2)

- 1.6 Light emitted from a distant star contains a spectral line X of frequency f . The spectral lines of this star when observed on Earth are red shifted.

Which ONE of the following combinations of the OBSERVED FREQUENCY of spectral line X and the MOTION OF THE STAR is CORRECT?

	OBSERVED FREQUENCY	MOTION OF THE STAR
A	Greater than f	Away from Earth
B	Greater than f	Towards Earth
C	Smaller than f	Away from Earth
D	Smaller than f	Towards Earth

(2)

- 1.7 A proton and an electron are a distance r apart. The magnitude of the electrostatic force that they exert on each other is F .

Which ONE of the following graphs shows the relationship between F and r^2 as the proton and the electron approach each other?

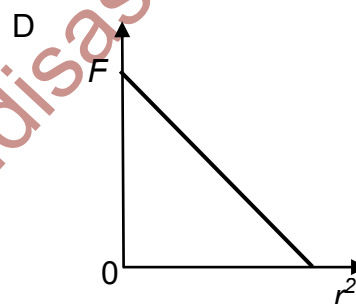
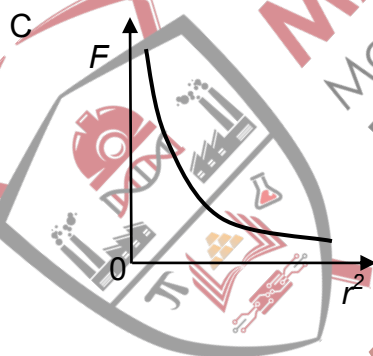
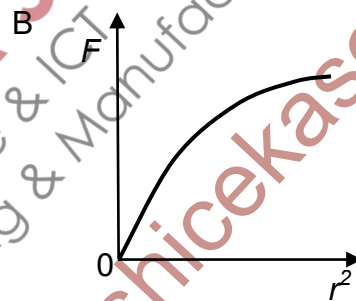
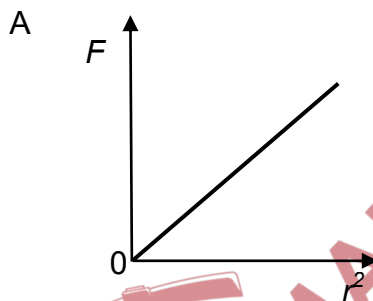

(2)

- 1.8 The emf of a battery is \mathcal{E} and its internal resistance is r . The battery is connected to three resistors and four voltmeters, as shown below. The resistance of the conducting wires is negligible, while the voltmeters have very high resistances.

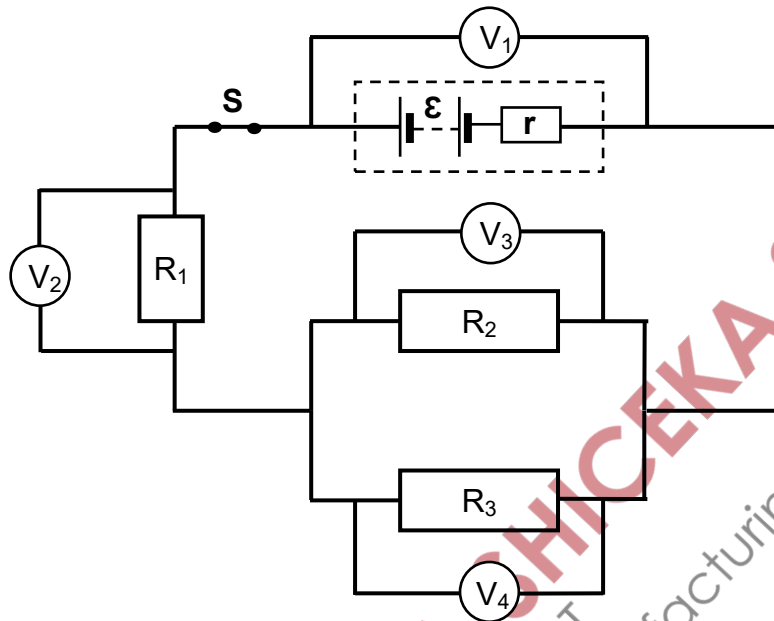

Which ONE of the following equations represents the reading on voltmeter V_1 in terms of the readings on the other voltmeters?

- A $V_1 = V_2 + V_3$
 B $V_1 = V_2 + -V_3$
 C $V_1 = V_2 + V_3 + V_4$
 D $V_1 = V_2 + 2V_3$

(2)

1.9 An AC generator consists of a coil which is rotated in a magnetic field. The emf time graph for one complete rotation of the coil is shown below.

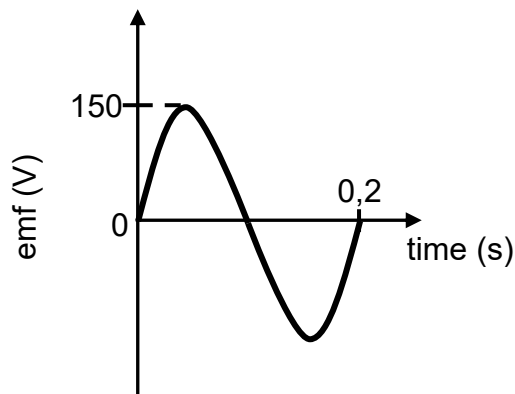

If the speed of rotation of the coil is now DOUBLED, which ONE of the following graphs is CORRECT for one complete rotation of the coil?

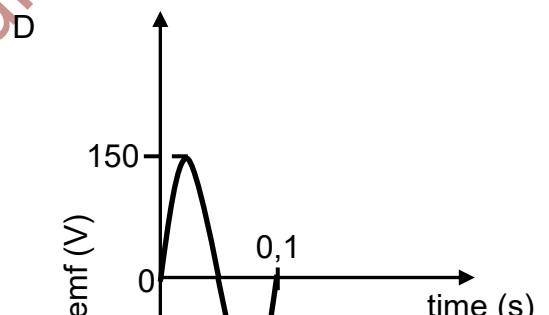
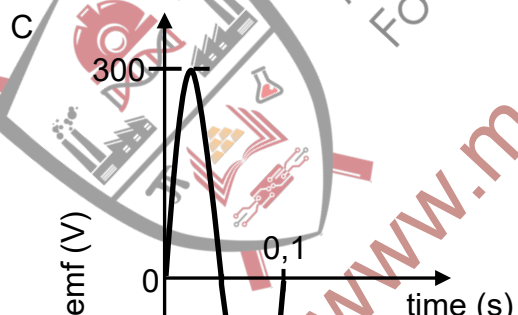
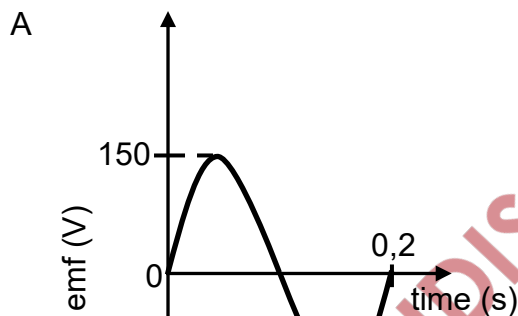

(2)

- 1.10 White light is passed through a cold gas and then through a prism, as shown below. A line spectrum is observed on the screen.

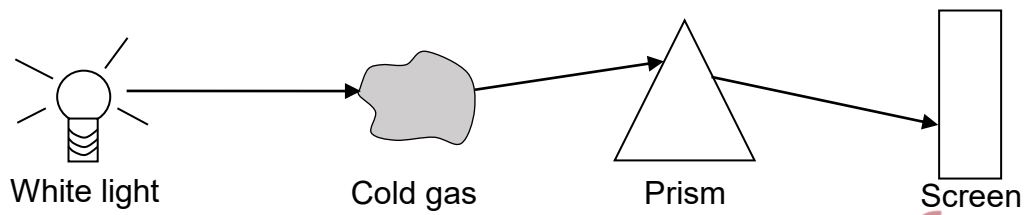

Which ONE of the following correctly describes the ENERGY TRANSITION of the atoms of the gas and the TYPE OF LINE SPECTRUM observed on the screen?

	ENERGY TRANSITION	TYPE OF LINE SPECTRUM
A	Higher to lower energy level	Emission
B	Lower to higher energy level	Emission
C	Higher to lower energy level	Absorption
D	Lower to higher energy level	Absorption

(2)
[20]



QUESTION 2 (Start on a new page.)

Crate **P** of mass 1,25 kg is connected to another crate, **Q**, of mass 2 kg by a light inextensible string. The two crates are placed on a rough horizontal surface. A constant force **F** of magnitude 7,5 N, acting at angle θ to the horizontal, is applied on crate **Q**, as shown in the diagram below.

The crates accelerate at $0, \text{ m}\cdot\text{s}^{-2}$ to the right.



Crate **P** experiences a constant frictional force of 1,8 N and crate **Q** experiences a constant frictional force of 2,2 N.

- 2.1 State Newton's Second Law of Motion in words. (2)
- 2.2 Draw a labelled free-body diagram for crate **P**. (4)
- 2.3 Calculate the magnitude of:
- 2.3.1 The tension in the string (4)
- 2.3.2 Angle θ (3)
- [13]**

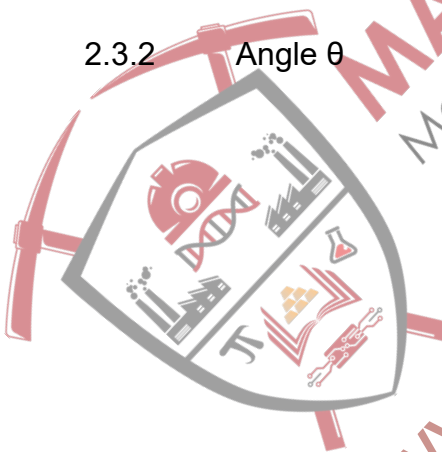

Maths, Science & Manufacturing
Focus: Mining & Manufacturing

QUESTION 3 (Start on a new page.)

A ball is thrown vertically upwards from the top of a building of height 25 m with a velocity of $\text{m}\cdot\text{s}^{-1}$. On its way down, the ball passes a door which has a height of 1,9 m and then strikes the ground, as shown in the diagram below.

Ignore the effects of air friction.

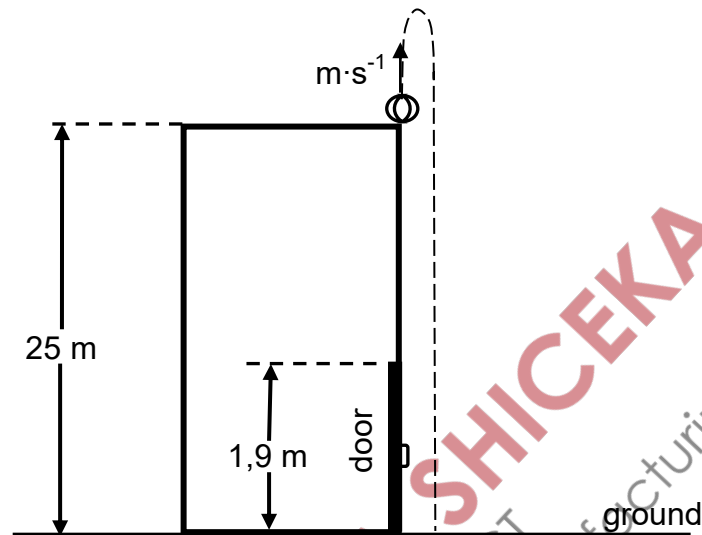

- 3.1 Define the term *free fall*. (2)
- 3.2 Calculate the:
- 3.2.1 Time taken for the ball to reach its maximum height (3)
- 3.2.2 Velocity with which the ball strikes the ground (4)
- 3.2.3 Time it took the ball to move from the top of the door to the ground (4)
- 3.3 Draw a velocity versus time graph for the motion of the ball from the moment that the ball is thrown upwards until it strikes the ground. Use the ground as zero reference. (3)
- Clearly indicate the following on your graph:
- The velocity with which the ball was thrown upwards
 - Time taken by the ball to reach its maximum height
 - The velocity with which the ball strikes the ground
- [16]

QUESTION 4 (Start on a new page.)

Trolley X of mass $1,2 \text{ kg}$ travels at $8 \text{ m}\cdot\text{s}^{-1}$ east and collides with trolley Y of mass $0,5 \text{ kg}$ which is initially at rest.

Ignore all frictional effects.

The velocity-time graph below shows the velocity of trolley X before, during and after the collision with trolley Y.

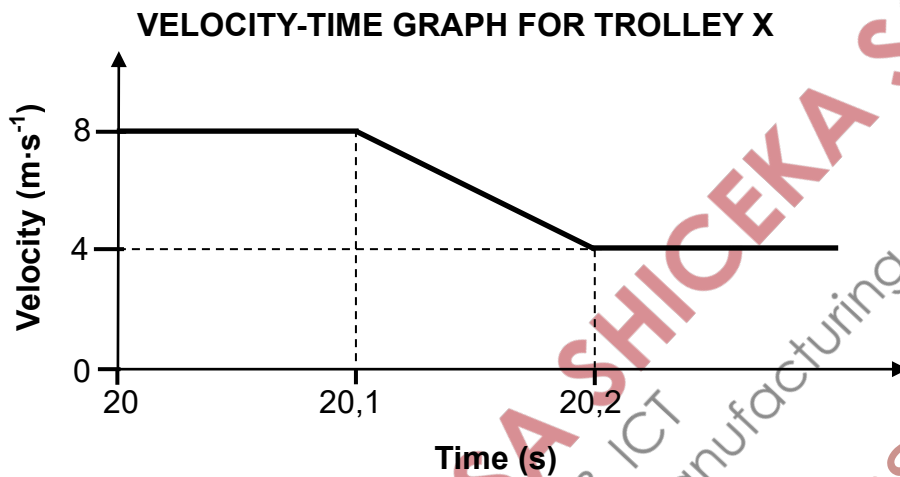

- 4.1 State the *principle of conservation of linear momentum*. (2)
- 4.2 Calculate the magnitude of the:
- 4.2.1 Velocity of trolley Y immediately after the collision (4)
- 4.2.2 Average net force that trolley X exerts on trolley Y during the collision (3)
- 4.3 Is the collision ELASTIC or INELASTIC? (5)
Explain the answer by means of suitable calculations. [14]

QUESTION 5 (Start on a new page.)

A 12 kg block is initially at rest at point **A** at the bottom of a ROUGH inclined plane. The block is pulled up the incline by a constant force **F** acting parallel to the incline. The block reaches point **B**, which is at a vertical height of 4,5 m above the horizontal, with a speed of $2,25 \text{ m}\cdot\text{s}^{-1}$. See the diagram below.

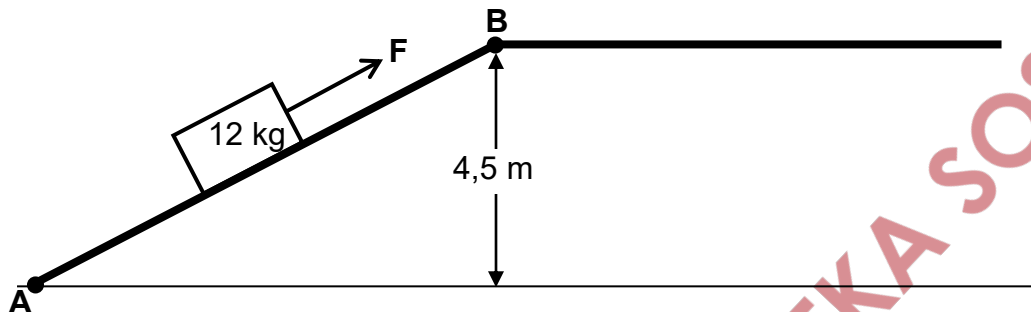

- 5.1 Define the term *non-conservative force*. (2)
- 5.2 Draw a labelled free-body diagram for the block when it is pulled up the inclined plane. (4)
- 5.3 Calculate the total work done on the block by the NON-CONSERVATIVE forces when the block moved from point **A** to point **B**. (4)

The same constant force **F** now moves the block at a CONSTANT VELOCITY across a rough horizontal surface from point **B** to point **C**, as shown below. Force **F** acts parallel to the horizontal surface.

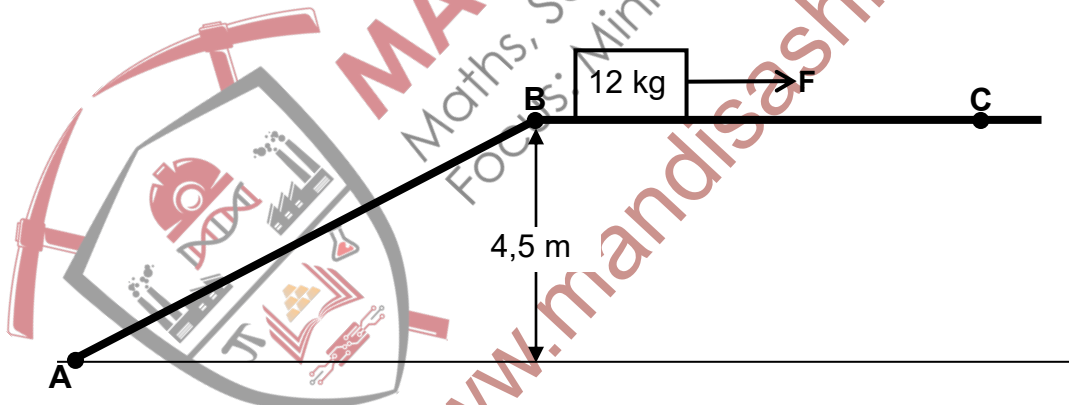

The magnitude of the constant frictional force acting on the block while moving from point **B** to point **C** is 42 N LARGER than the magnitude of the constant frictional force acting on the block when it moves from point **A** to point **B**.

- 5.4 Calculate the distance from point **A** to point **B**. (5)
[15]

QUESTION 6 (Start on a new page.)

A learner investigates the relationship between the observed frequency and the frequency of sound waves emitted by a stationary source.

The learner moves towards the source at a constant velocity and records the observed frequency (f_L) for a given source frequency (f_s). This process is repeated for different frequencies of the source, with the learner moving at the same constant velocity each time.

The graph below shows how the observed frequency changes as the frequency of sound waves emitted by the source changes.

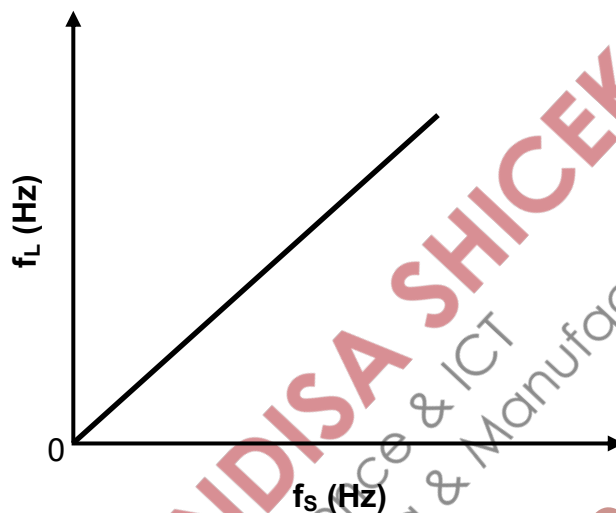

- 6.1 Name the phenomenon illustrated by the graph. (1)
- 6.2 Name ONE application in the medical field of the phenomenon in QUESTION 6.1. (1)
- 6.3 Write down the type of proportionality that exists between f_L and f_s , as illustrated by the graph. (1)
- 6.4 The gradient of the graph obtained is found to be 1,06.
If the speed of sound in air is $340 \text{ m}\cdot\text{s}^{-1}$, calculate the magnitude of the velocity at which the learner approaches the source. (5)
- The investigation is now repeated with the learner moving at a HIGHER constant velocity towards the sound source.
- 6.5 Copy the graph above in your ANSWER BOOK and label it as **A**. On the same set of axes, sketch the graph that will be obtained when the learner is moving at the HIGHER velocity. Label this graph as **B**. (2)

[10]

QUESTION 7 (Start on a new page.)

A charged sphere **M** is suspended from a ceiling by a light inextensible, insulated string.

Another charged sphere **N**, of mass $2,04 \times 10^{-3}$ kg and carrying a charge of $+ 8,6 \times 10^{-8}$ C, hangs STATIONARY vertically below sphere **M**. The centres of the spheres are 0,3 m apart, as shown in the diagram below.

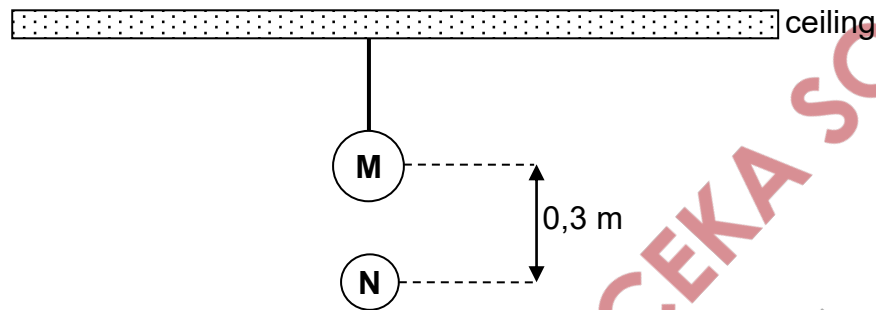

- 7.1 State Coulomb's law in words. (2)
- 7.2 State whether the charge on sphere **M** is POSITIVE or NEGATIVE. (1)
- 7.3 Draw a labelled free-body diagram for sphere **N**. (2)
- 7.4 Calculate the magnitude of the charge on sphere **M**. (5)
- 7.5 How does the electrostatic force that sphere **M** exerts on sphere **N** compare to that exerted by sphere **N** on sphere **M** with respect to:
- 7.5.1 Magnitude (1)
- 7.5.2 Direction (1)

Point **X** is 0,1 m vertically below the centre of sphere **N**, as shown below.

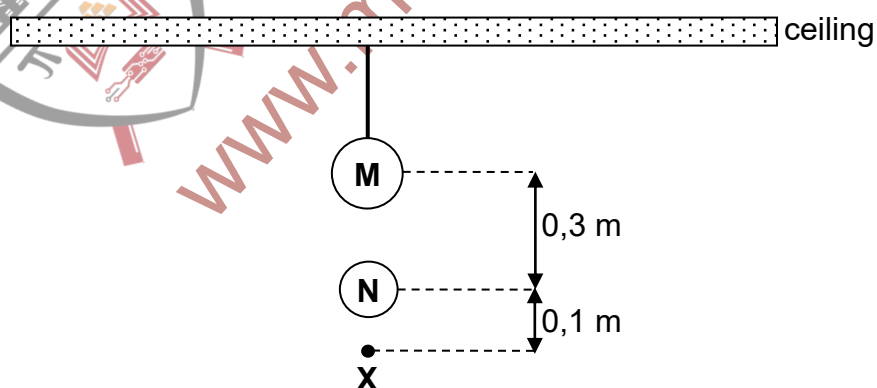

- 7.6 Calculate the net electric field at point **X**. (5)
- [17]**

QUESTION 8 (Start on a new page.)

The circuit diagram below shows four resistors connected to a battery of emf \mathcal{E} and internal resistance r . The resistances of the ammeter and the connecting wires are negligible, while the voltmeters have very high resistances.

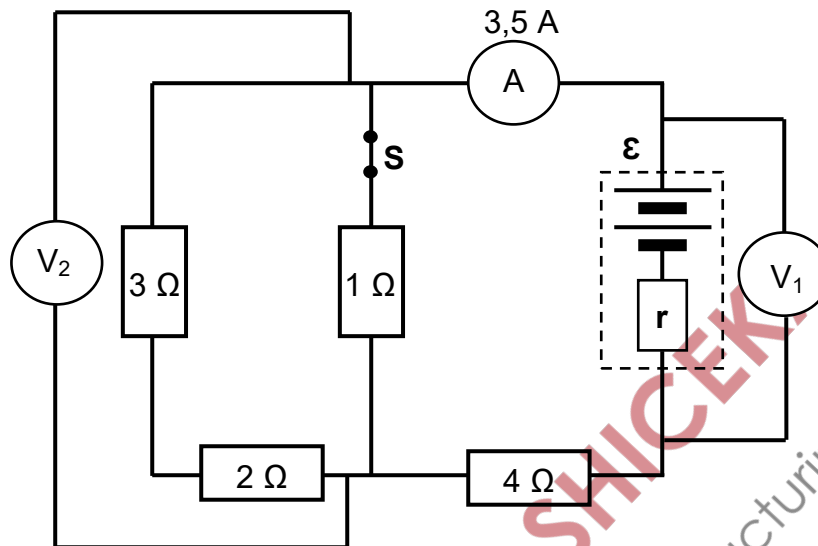

- 8.1 State Ohm's law in words. (2)
- Switch **S** is CLOSED.
- 8.2 The reading on the ammeter is 3,5 A.
- 8.2.1 Calculate the total external resistance of the circuit. (4)
- 8.2.2 Calculate the reading on voltmeter V_1 . (3)
- 8.2.3 How does the reading on voltmeter V_2 compare to the reading on voltmeter V_1 ? Choose from SMALLER THAN, EQUAL TO or GREATER THAN. (1)
- 8.3 A learner concludes that the emf of the battery is equal to the reading on voltmeter V_1 .
- 8.3.1 Define the term *emf*. (2)
- 8.3.2 Is the learner's conclusion CORRECT? Choose from YES or NO. (1)
- 8.3.3 Give a reason for the answer to QUESTION 8.3.2. (1)

Switch **S** is now removed and replaced by voltmeter V_2 , as shown in the circuit diagram below.

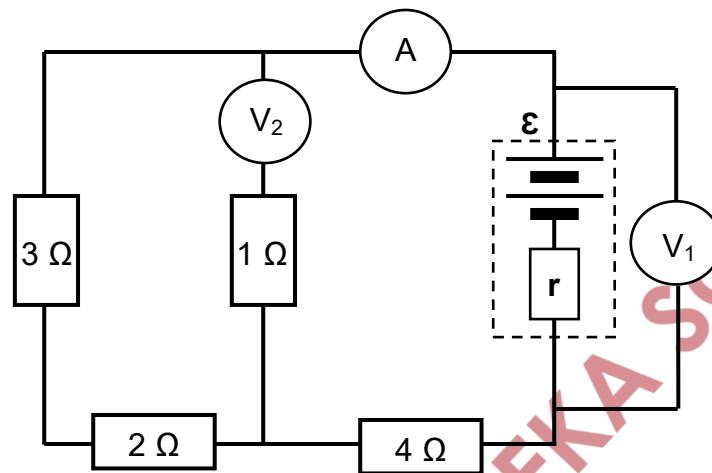

8.4 How will EACH of the following change?

(Choose from INCREASES, DECREASES or REMAINS THE SAME.)

8.4.1 The power dissipated by the $4\ \Omega$ resistor (1)

8.4.2 The reading on voltmeter V_1 (1)

8.5 Explain the answer to QUESTION 8.4.2. (4)
[20]



Maths, Science & ICT
Focus: Mining & Manufacturing

www.mandisashicekasos.com

QUESTION 9 (Start on a new page.)

- 9.1 The diagram below shows the initial position of the coil in a simple DC generator. The coil is rotated in an anticlockwise direction, as shown.

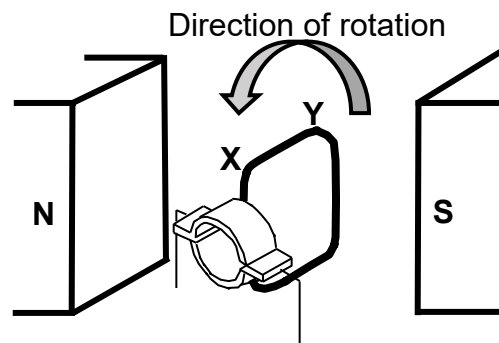

- 9.1.1 Name the component in this generator that ensures that the induced current in the external circuit is in one direction only. (1)
- 9.1.2 Is the direction of the induced current from **X to Y** or from **Y to X**? (1)

A maximum voltage of 90 V is generated when the coil is rotating at a frequency of 20 Hz.

- 9.1.3 Write down the time taken for the coil to complete ONE rotation. (1)
- 9.1.4 The coil starts rotating from the initial position, as shown in the diagram above.

Sketch a graph of output voltage versus time for one complete rotation of the coil. Indicate the maximum voltage and the relevant time values on the graph. (4)

- 9.2 Wall sockets supply rms voltage and current.

A 220 V AC voltage is supplied from a wall socket to an electric kettle having a resistance of 32 Ω .

Calculate the average energy dissipated by the kettle in TWO minutes. (4)
[11]

QUESTION 10 (Start on a new page.)

Light is incident on the cathode of a photoelectric cell connected to a battery and a sensitive ammeter, as shown below.

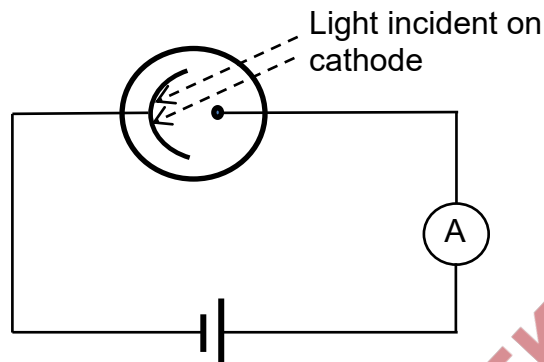

- 10.1 What conclusive evidence about the nature of light is provided by the photoelectric effect? (1)

The cathode has a work function of $3,42 \times 10^{-19}$ J.

- 10.2 Define the term *work function*. (2)

Light of frequency $5,96 \times 10^{14}$ Hz is shone onto the cathode.

- 10.3 Calculate the maximum kinetic energy of an electron ejected from the cathode. (4)

- 10.4 The ammeter registers a constant current of 0,012 A.

Calculate the minimum number of photons of light that strike the cathode in a 10 s period. (4)

- 10.5 The intensity of the incident light is now INCREASED. How will this change affect the reading on the ammeter?

Choose from INCREASES, DECREASES or REMAINS THE SAME. Explain the answer. (3)

[14]

TOTAL: 150

**DATA FOR PHYSICAL SCIENCES GRADE 12
PAPER 1 (PHYSICS)**

**GEGEWENS VIR FISIESTE WETENSKAPPE GRAAD 12
VRAESTEL 1 (FISIKA)**

TABLE 1: PHYSICAL CONSTANTS/TABEL 1: FISIESTE KONSTANTES

NAME/NAAM	SYMBOL/SIMBOOL	VALUE/WAARDE
Acceleration due to gravity <i>Swaartekragversnelling</i>	g	9,8 m·s ⁻²
Universal gravitational constant <i>Universele gravitasiekonstant</i>	G	6,67 x 10 ⁻¹¹ N·m ² ·kg ⁻²
Radius of the Earth <i>Radius van die Aarde</i>	R _E	6,38 x 10 ⁶ m
Mass of the Earth <i>Massa van die Aarde</i>	M _E	5,98 x 10 ²⁴ kg
Speed of light in a vacuum <i>Spoe van lig in 'n vakuum</i>	c	3,0 x 10 ⁸ m·s ⁻¹
Planck's constant <i>Planck se konstante</i>	h	6,63 x 10 ⁻³⁴ J·s
Coulomb's constant <i>Coulomb se konstante</i>	k	9,0 x 10 ⁹ N·m ² ·C ⁻²
Charge on electron <i>Lading op elektron</i>	e	-1,6 x 10 ⁻¹⁹ C
Electron mass <i>Elektronmassa</i>	m _e	9,11 x 10 ⁻³¹ kg



MANDISA SHICEKA
Maths, Science & ICT
Focus: Mining & Manufacturing
www.mandisashiceka.co.za

TABLE 2: FORMULAE/TABEL 2: FORMULES**MOTION/BEWEGING**

$v_f \square v_i \square a \square t$	$\Delta x \square v_i \Delta t \square \frac{1}{2} a \Delta t^2$ or/of $\Delta y \square v_i \Delta t \square \frac{1}{2} a \Delta t^2$
$v_f^2 \square v_i^2 \square 2a \square x$ or/of $v_f^2 \square v_i^2 \square 2a \square y$	$\Delta x \square \frac{v_i \square v_f}{2} \Delta t$ or/of $\Delta y \square \frac{v_i \square v_f}{2} \Delta t$

FORCE/KRAG

$F_{net} \square ma$	$p \square mv$
$f_s^{max} = \mu_s N$	$f_k = \mu_k N$
$F_{net} \Delta t = \Delta p$ $\Delta p = mv_f - mv_i$	$w \square mg$
$F = G \frac{m_1 m_2}{d^2}$ or/of $F = G \frac{m_1 m_2}{r^2}$	$g \square G \frac{M}{d^2}$ or/of $g \square G \frac{M}{r^2}$

WORK, ENERGY AND POWER/ARBEID, ENERGIE EN DRYWING

$W = F \Delta x \cos \square$	$U \square mgh$ or/of $E_p \square mgh$
$K \square \frac{1}{2} mv^2$ or/of $E_k \square \frac{1}{2} mv^2$	$W_{net} \square \square K$ or/of $W_{net} \square \square E_k$ $\square K \square K_f \square K_i$ or/of $\square E_k \square E_{kf} \square E_{ki}$
$W_{nc} \square \square K \square \square U$ or/of $W_{nc} \square \square E_k \square \square E_p$	$P \square \frac{W}{t}$
$P_{ave} = Fv_{ave}$ / $P_{gemid} = Fv_{gemid}$	

WAVES, SOUND AND LIGHT/GOLWE, KLANK EN LIG

$v \square f \square \square$	$T \square \frac{1}{f}$
$f_L \square \frac{v \square v_L}{v \square v_s} f_s$ / $f_L \square \frac{v \square v_L}{v \square v_b} f_b$	$E \square hf$ or/of $E \square \frac{hc}{\square}$
$E \square W_o \square E_{k(max)}$ or/of $E \square W_o \square K_{max}$ where/waar	
$E \square hf$ and/en $W_o \square hf_o$ and/en $E_{k(max)} \square \frac{1}{2} mv_{max}^2$ or/of $K_{max} \square \frac{1}{2} mv_{max}^2$	

ELECTROSTATICS/ELEKTROSTATIKA

$F \propto \frac{kQ_1Q_2}{r^2}$	$E \propto \frac{kQ}{r^2}$
$V \propto \frac{W}{q}$	$E \propto \frac{F}{q}$
$n = \frac{Q}{e}$ or/of $n = \frac{Q}{q_e}$	

ELECTRIC CIRCUITS/ELEKTRIESE STROOMBANE

$R \propto \frac{V}{I}$	emf (ϵ) = I(R + r) emk (ϵ) = I(R + r)
$R_s \propto R_1 \propto R_2 \propto \dots$ $\frac{1}{R_p} \propto \frac{1}{R_1} \propto \frac{1}{R_2} \propto \dots$	$q \propto I \Delta t$
$W = Vq$ $W = VI \Delta t$ $W = I^2 R \Delta t$ $W = \frac{V^2 \Delta t}{R}$	$P \propto \frac{W}{\Delta t}$ $P = VI$ $P \propto I^2 R$ $P \propto \frac{V^2}{R}$

ALTERNATING CURRENT/WISSELSTROOM

$I_{rms} \propto \frac{I_{max}}{\sqrt{2}}$ / $I_{wgk} \propto \frac{I_{maks}}{\sqrt{2}}$	$P_{ave} \propto V_{rms} I_{rms}$ / $P_{gemid} \propto V_{wgk} I_{wgk}$
$V_{rms} \propto \frac{V_{max}}{\sqrt{2}}$ / $V_{wgk} \propto \frac{V_{maks}}{\sqrt{2}}$	$P_{ave} \propto I_{rms}^2 R$ / $P_{gemid} \propto I_{wgk}^2 R$
	$P_{ave} \propto \frac{V_{rms}^2}{R}$ / $P_{gemid} \propto \frac{V_{wgk}^2}{R}$