



basic education

Department:
Basic Education
REPUBLIC OF SOUTH AFRICA

SENIOR CERTIFICATE EXAMINATIONS/ NATIONAL SENIOR CERTIFICATE EXAMINATIONS

PHYSICAL SCIENCES: PHYSICS (P1)

2023

MARKS: 150

TIME: 3 hours

This question paper consists of 16 pages and 3 data sheets.

INSTRUCTIONS AND INFORMATION

1. Write your centre number and examination number in the appropriate spaces on the ANSWER BOOK.
2. This question paper consists of 10 questions. Answer ALL the questions in the ANSWER BOOK.
3. Start EACH question on a NEW page in the ANSWER BOOK.
4. Number the answers correctly according to the numbering system used in this question paper.
5. Leave ONE line between two subquestions, e.g. between QUESTION 2.1 and QUESTION 2.2.
6. You may use a non-programmable calculator.
7. You may use appropriate mathematical instruments.
8. Show ALL formulae and substitutions in ALL calculations.
9. Round off your FINAL numerical answers to a minimum of TWO decimal places.
10. Give brief motivations, discussions, etc. where required.
11. You are advised to use the attached DATA SHEETS.
12. Write neatly and legibly.



MANDISA CHICEKA SOS
Maths, Science & ICT
Focus: Mining & Manufacturing

www.mandisachicekasos.com

QUESTION 1: MULTIPLE-CHOICE QUESTIONS

Various options are provided as possible answers to the following questions. Each question has only ONE correct answer. Choose the answer and write only the letter (A–D) next to the question numbers (1.1 to 1.10) in the ANSWER BOOK, e.g. 1.11 E.

- 1.1 Which ONE of the following quantities is the tendency of an object to resist a change to its state of motion?
- A Inertia
B Impulse
C Momentum
D Acceleration (2)
- 1.2 A ball is dropped from rest at a height above a concrete floor. The ball strikes the floor and bounces vertically up and down on the same spot on the floor.

The velocity-time graph for the bouncing ball is shown below, with points **P**, **Q**, **R** and **S** representing different times during the motion.

Ignore the effects of air resistance.

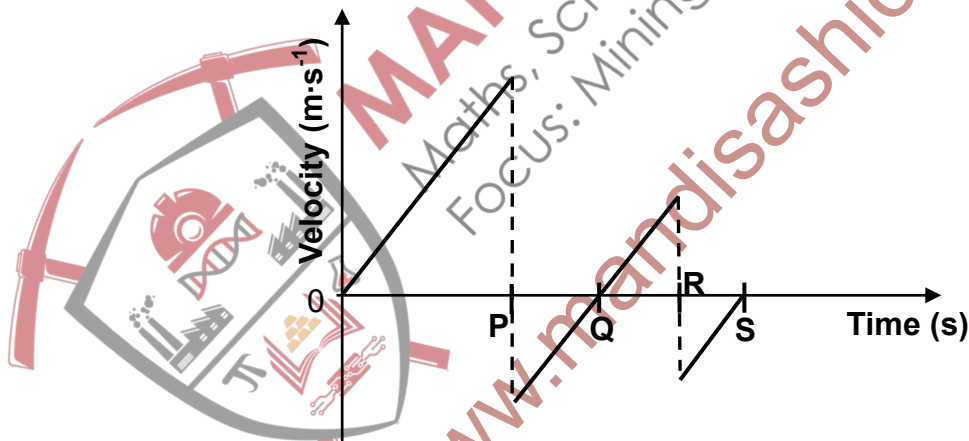

At which time does the ball reach its maximum height after the first upward bounce?

- A P
B Q
C R
D S (2)

- 1.3 Two blocks, **P** and **Q**, of masses m_1 and m_2 respectively, are held at rest on a frictionless horizontal floor with a compressed spring between them, as shown below.

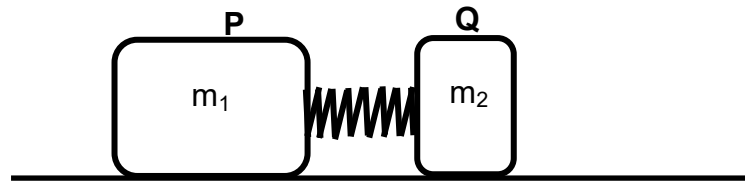

When the blocks are released and the spring drops to the floor, block **Q** moves to the right with velocity v .

Which ONE of the following represents the momentum of block **P** after the blocks are released?

- A m_1v to the right
- B m_2v to the right
- C m_1v to the left
- D m_2v to the left

(2)

- 1.4 The magnitude of the gravitational force that spheres **X** and **Y** exert on each other is F .

The mass of sphere **X** is now doubled while the mass of sphere **Y** and the distance between the centres of the spheres remain the same.

Which ONE of the following combinations is CORRECT for the magnitude of the forces that the spheres now exert on each other?

| | FORCE THAT X EXERTS ON Y | FORCE THAT Y EXERTS ON X |
|---|--------------------------|--------------------------|
| A | F | F |
| B | F | $2F$ |
| C | $2F$ | F |
| D | $2F$ | $2F$ |

(2)

- 1.5 A hot-air balloon is moving vertically downwards at a CONSTANT SPEED. Assume that the mass of the hot-air balloon remains constant.

Which ONE of the following physical quantities associated with the hot-air balloon changes during the motion?

- A Weight
 - B Momentum
 - C Kinetic energy
 - D Potential energy
- (2)

- 1.6 A learner standing at a roadside records the frequency of sound waves produced by the siren of an ambulance. The ambulance is moving at constant velocity along a straight horizontal road.

The frequency-time graph for the detected sound is shown below.



Which ONE of the following statements concerning the motion of the ambulance is CORRECT?

The ambulance...

- A approaches the learner and then passes the learner.
 - B moves away from the learner, then turns and approaches the learner.
 - C approaches the learner, then turns and moves away from the learner.
 - D moves away from the learner and then stops.
- (2)

- 1.7 Two identically charged spheres, **X** and **Y**, carry charges of $+2q$ and $-6q$ respectively.

Sphere **X** experiences an electrostatic force **F** to the right when the distance between their centres is r .

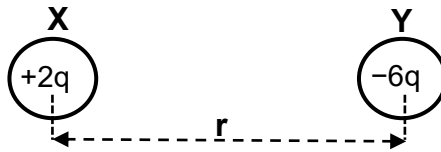

The spheres are brought into contact and are then returned to their original positions.

Which ONE of the following represents the magnitude of the electrostatic force that sphere **X** experiences now?

- A $-F$
 B $-F$
 C $4F$
 D $12F$

(2)

- 1.8 In the circuit diagram below, R_1 , R_2 and R_3 are identical resistors. The battery has negligible internal resistance.

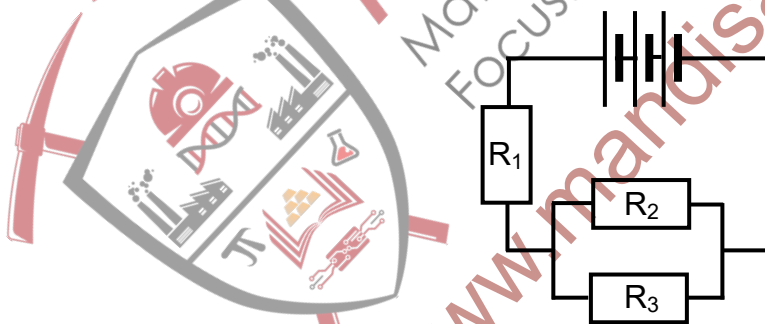

The power dissipated by R_1 is P .

Which ONE of the following is the power dissipated by R_2 ?

- A $-P$
 B $\frac{P}{2}$
 C $2P$
 D $4P$

(2)

1.9 The simplified diagram below represents a DC motor.

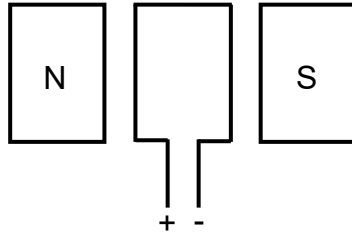

The diagrams below indicate some changes made to the above motor.

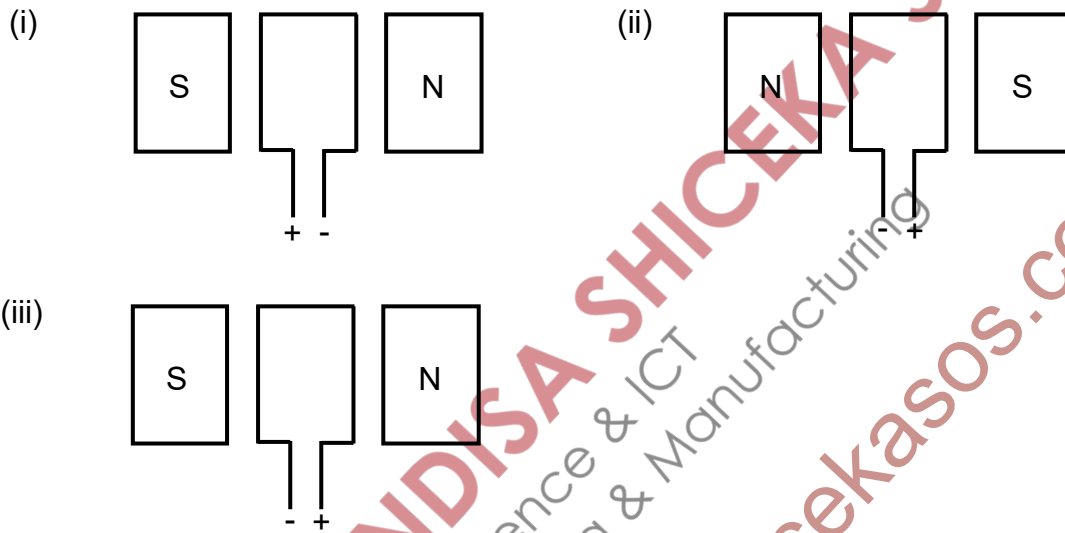

Which of the changes to the motor above will change the original direction of rotation of the coil?

- A (i) and (ii) only
 B (i) and (iii) only
 C (ii) and (iii) only
 D (iii) only

(2)

1.10 An atom has a ground state energy of x . When the atom moves to a higher energy state y , a line spectrum is observed.

Which ONE of the following combinations is CORRECT for the ENERGY CHANGE of the atom and the TYPE OF LINE SPECTRUM observed during the transition?

| | ENERGY CHANGE | TYPE OF LINE SPECTRUM |
|---|---------------|-----------------------|
| A | $y - x$ | Emission |
| B | $x - y$ | Emission |
| C | $x - y$ | Absorption |
| D | $y - x$ | Absorption |

(2)
[20]

QUESTION 2 (Start on a new page.)

Block **A** of mass m is connected to block **B** of mass $7,5 \text{ kg}$ by a light inextensible rope passing over a frictionless pulley. Block **B** is initially held at a height of $1,5 \text{ m}$ above the ground, while block **A** is initially stationary on the ground, as shown in the diagram below.

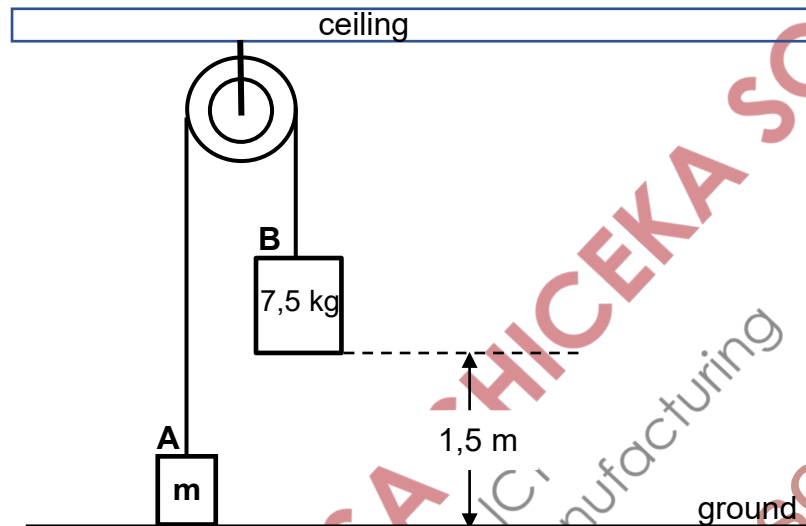

When block **B** is released, it moves vertically downwards and strikes the ground with a velocity of $3,41 \text{ m}\cdot\text{s}^{-1}$.

Ignore the effects of friction.

- 2.1 Show, by means of a calculation, that the magnitude of the acceleration of block **B** was $3,88 \text{ m}\cdot\text{s}^{-2}$ while the block was moving vertically downwards. (3)
- 2.2 Draw a labelled free-body diagram showing ALL the forces acting on block **B** immediately after it was released. (2)
- 2.3 State Newton's Second Law of Motion in words. (2)
- 2.4 Calculate the value of m by applying Newton's Second Law to EACH BLOCK while they are in motion. (5)
- 2.5 Calculate the maximum height above the ground reached by block **A**. (5)

[17]

QUESTION 3 (Start on a new page.)

Ball **A** is dropped from rest from the top of a building 15,2 m high.

After ball **A** has fallen 3,2 m, a second ball **B** is projected vertically upwards from the ground. After a while, the two balls strike the ground at the SAME time.

Ignore the effects of air resistance.

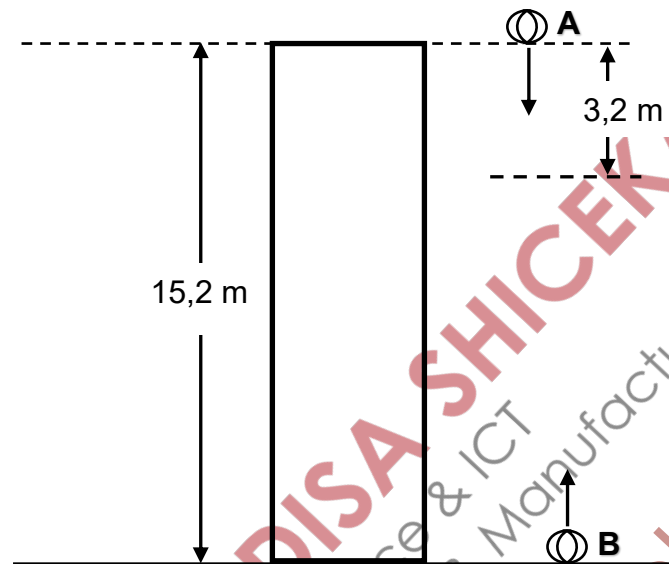

3.1 Define the term *free fall*. (2)

3.2 Calculate the:

3.2.1 Time taken for ball **A** to strike the ground (3)

3.2.2 Magnitude of the velocity with which ball **B** was projected from the ground (5)

3.3 On the same system of axes, draw position-time graphs to show the motions of both ball **A** and ball **B** from the instant ball **A** is dropped until the time it reaches the ground.

Take the ground as the zero position.

Label the graphs **A** and **B**.

Clearly indicate the following on the graphs:

- The starting time for each ball
- The initial position of each ball
- The time when the balls strike the ground

(5)
[15]

QUESTION 4 (Start on a new page.)

Trolley **A** of mass 7,2 kg moves to the right at $0,4 \text{ m}\cdot\text{s}^{-1}$ in a straight line on a horizontal floor. It collides with a stationary trolley **B** of mass 5,3 kg.

After the collision, the trolleys lock together and move to the right, as shown in the diagram below.

Ignore any frictional effects.



- 4.1 State the *principle of conservation of linear momentum* in words. (2)
- 4.2 Calculate the magnitude of the:
- 4.2.1 Velocity of the trolleys immediately after the collision (3)
- 4.2.2 Average net force exerted by trolley **A** on trolley **B** during the collision, if the collision time is 0,02 s (3)
- [8]

QUESTION 5 (Start on a new page.)

An electric motor pulls a 20 kg crate from rest at point **A** up an inclined plane by means of a light inextensible rope. The inclined plane makes an angle of 18° with the horizontal. **B**, **C** and **D** are points on the inclined plane and the distance between points **A** and **C** is 15,6 m, as shown in the diagram below.

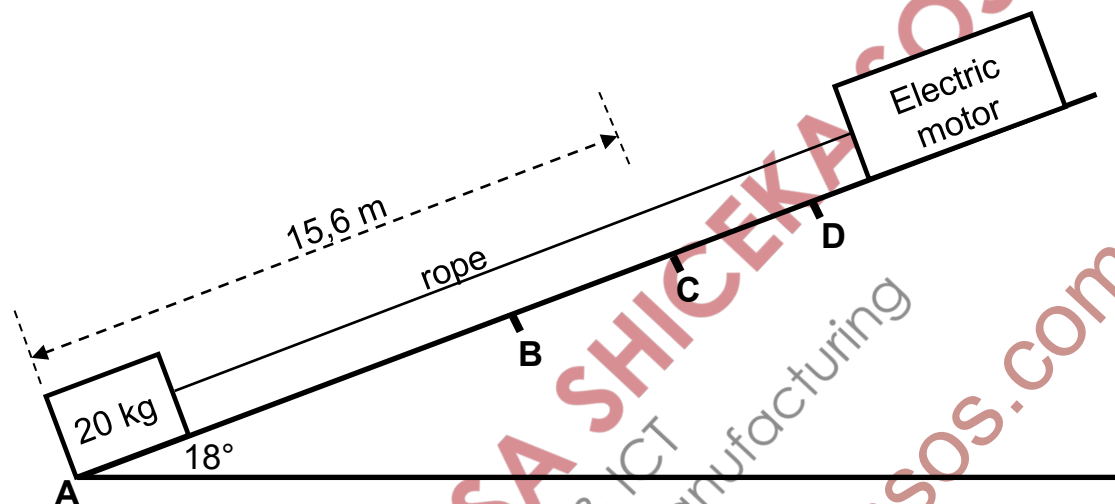

The motor exerts a constant force of 96,8 N parallel to the inclined plane on the rope.

A constant frictional force of 13,5 N acts on the crate as it moves on the inclined plane.

- 5.1 Define a *non-conservative force*. (2)
- 5.2 Use ENERGY PRINCIPLES to calculate the speed of the crate when it reaches point **C**. (5)
- 5.3 Calculate the minimum average power dissipated by the electric motor to pull the crate from point **A** to point **C**. (3)

When the crate reaches point **C**, the rope breaks. The crate continues moving up the inclined plane, comes to a stop at point **D**, and then slides down the plane past point **B**.

- 5.4 Draw a labelled free-body diagram for the crate as it slides down the plane past point **B**. (3)
- 5.5 Draw a velocity-time graph for the entire motion of the crate starting from point **A** until it passes point **B** again on its motion down the inclined plane. (4)
- [17]

QUESTION 6 (Start on a new page.)

- 6.1 A car moves at a constant velocity of $22 \text{ m}\cdot\text{s}^{-1}$ on a straight horizontal road TOWARDS a stationary device, which can both emit and detect sound waves.

The device emits sound waves with a frequency of 24 000 Hz. These sound waves are reflected off the car and the reflected sound waves are then detected by the device, as shown in the diagram below.

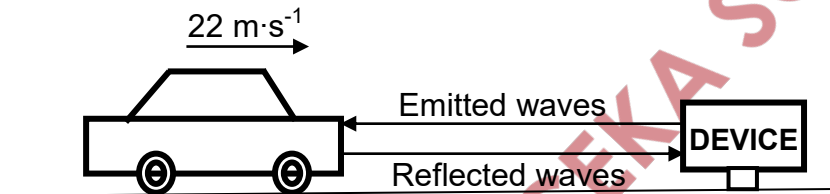

- 6.1.1 State the *Doppler effect* in words. (2)
- 6.1.2 If the speed of sound in air is $340 \text{ m}\cdot\text{s}^{-1}$, calculate the frequency of the reflected sound waves detected by the device. (6)
- 6.2 The spectral lines observed for a distant star show that the star is moving away from Earth. Explain, by referring to frequency, how one can deduce that the star is moving away from Earth. (2)

[10]

QUESTION 7 (Start on a new page.)

Two point charges, **X** and **Y**, are held 0,03 m apart, as shown in the diagram below. The charge of **X** is $-7,2 \times 10^{-9}$ C, while the charge of **Y** is $+7,2 \times 10^{-9}$ C.

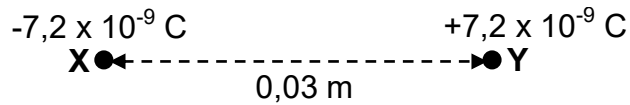

- 7.1 State Coulomb's law in words. (2)
- 7.2 Draw the net electric field pattern due to the two point charges. (3)
- 7.3 Calculate the magnitude of the electrostatic force that **Y** exerts on **X**. (3)

A third point charge, **Z**, of unknown positive charge, is positioned 0,01 m to the left of point charge **X** on the line joining point charges **X** and **Y**, as shown in the diagram below.

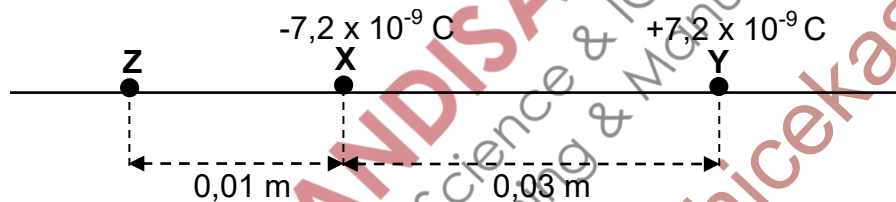

- 7.4 Draw a labelled vector diagram to show the directions of the electric fields at the point where **X** is positioned. (2)
- 7.5 The magnitude of the resultant electric field at the point where **X** is positioned is $4,91 \times 10^5$ N·C⁻¹. Calculate the magnitude of charge **Z**. (5)

[15]

QUESTION 8 (Start on a new page.)

A battery with unknown emf (\mathcal{E}) and unknown internal resistance (r) is connected to three resistors, a high-resistance voltmeter, two switches and two ammeters of negligible resistance, as shown below.

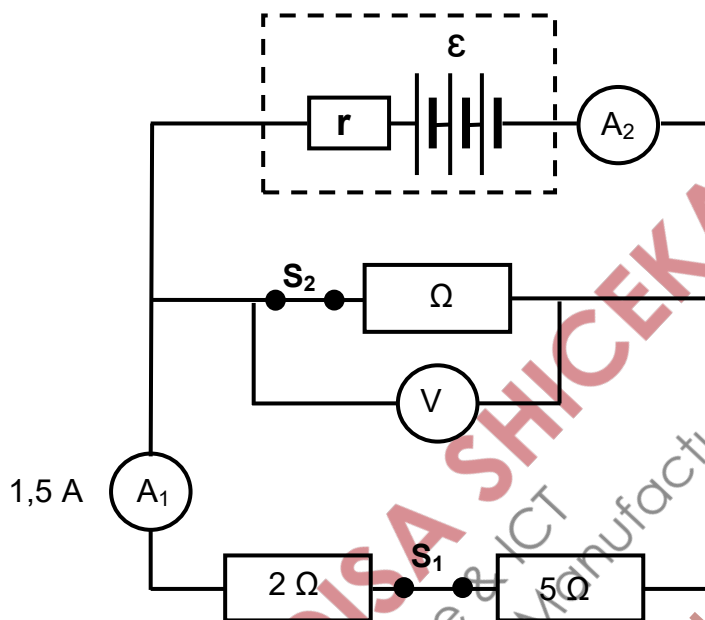

8.1 State Ohm's law in words. (2)

Both switch S_1 and switch S_2 are CLOSED. The reading on ammeter A_1 is 1,5 A.

8.2 Calculate the:

8.2.1 Reading on the voltmeter (3)

8.2.2 Reading on ammeter A_2 (4)

8.2.3 Power dissipated in the 3Ω resistor (3)

Switch S_1 is now OPENED, while switch S_2 remains CLOSED. The reading on ammeter A_2 is now 3,64 A.

8.3 Calculate the emf of the battery. (5)

Switch S_2 is now OPENED, while switch S_1 is CLOSED.

8.4 How does the voltmeter reading change? Choose from INCREASES, DECREASES or REMAINS THE SAME.

Explain the answer.

(4)
[21]

QUESTION 9 (Start on a new page.)

- 9.1 The simplified sketch below represents an AC generator with the coil initially horizontal between the poles of a magnet. **X** and **Y** are two points on the coil, while **A** is one of the poles of the magnet.

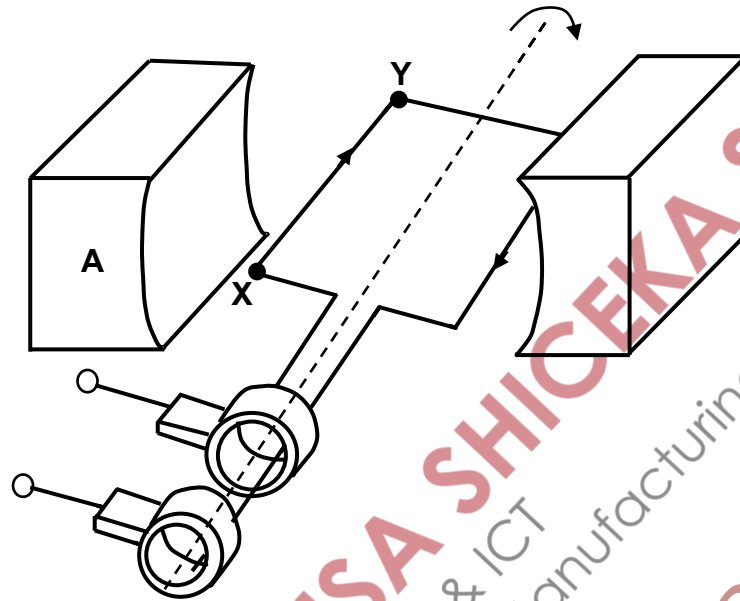

When the coil of the generator rotates clockwise between the two poles of the magnet, the direction of the induced current is from **X** to **Y**, as shown above.

- 9.1.1 Is **A** the NORTH POLE or the SOUTH POLE of the magnet? (1)
- 9.1.2 The coil is now rotated through 180° .
Will the direction of the current be from **X** to **Y** or from **Y** to **X**? (1)
- 9.1.3 Sketch an emf-time graph for TWO complete rotations of the coil, starting from the position of the coil as shown in the diagram above. (3)
- 9.2 An electrical device is connected to an AC generator. The rms potential difference across the device is 200 V and the maximum current passing through the device is 6 A.
- Calculate the:
- 9.2.1 Resistance of the device (4)
- 9.2.2 Energy consumed by the device in two hours (4)
- [13]

QUESTION 10 (Start on a new page.)

In a photoelectric investigation, light of different frequencies was radiated on each of two metals, **A** and **B**. The graph of maximum kinetic energy of the ejected electrons from metal **A** and the frequency of the incident photons is shown below.

Point **X** on the graph represents an unknown maximum kinetic energy.

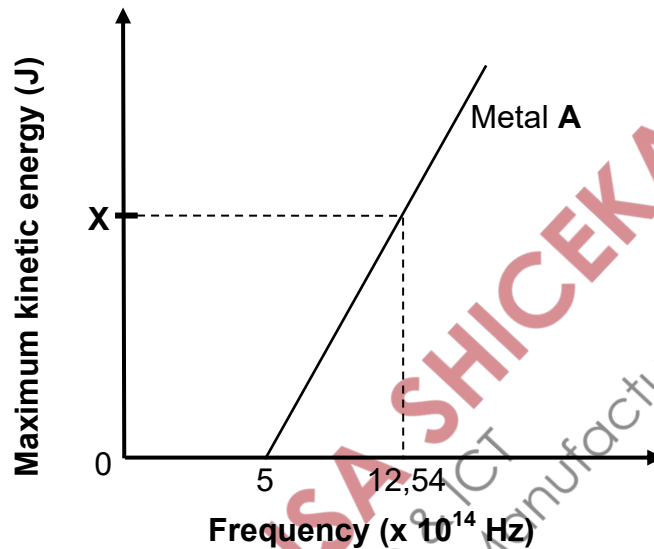

- 10.1 Write down the numerical value of the gradient of the graph. (1)
- 10.2 Define the term *work function*. (2)
- 10.3 Calculate the:
- 10.3.1 Work function of metal **A** (3)
- 10.3.2 Value of **X** shown on the graph (4)
- 10.4 How will EACH of the following be affected if light of frequency $12,54 \times 10^{14}$ Hz, but of higher intensity, is used?
Choose from INCREASES, DECREASES or NO EFFECT.
- 10.4.1 The value of **X** (1)
- 10.4.2 The number of photoelectrons emitted per unit time (1)

Metal **B** has a larger work function than metal **A**.

- 10.5 Redraw the graph above in your ANSWER BOOK. (Do NOT include values on the axes.) Label this graph as **A**.

On the SAME set of axes, sketch the graph for metal **B**. Label this graph as **B**.

(2)
[14]

TOTAL: 150

**DATA FOR PHYSICAL SCIENCES GRADE 12
PAPER 1 (PHYSICS)**

**GEGEWENS VIR FISIESTE WETENSKAPPE GRAAD 12
VRAESTEL 1 (FISIKA)**

TABLE 1: PHYSICAL CONSTANTS/TABEL 1: FISIESTE KONSTANTES

| NAME/NAAM | SYMBOL/SIMBOOL | VALUE/WAARDE |
|--|----------------|---|
| Acceleration due to gravity <i>Swaartekragversnelling</i> | g | 9,8 m·s ⁻² |
| Universal gravitational constant <i>Universele gravitasiekonstant</i> | G | 6,67 x 10 ⁻¹¹ N·m ² ·kg ⁻² |
| Radius of the Earth <i>Radius van die Aarde</i> | R _E | 6,38 x 10 ⁶ m |
| Mass of the Earth <i>Massa van die Aarde</i> | M _E | 5,98 x 10 ²⁴ kg |
| Speed of light in a vacuum <i>Spoed van lig in 'n vakuum</i> | c | 3,0 x 10 ⁸ m·s ⁻¹ |
| Planck's constant <i>Planck se konstante</i> | h | 6,63 x 10 ⁻³⁴ J·s |
| Coulomb's constant <i>Coulomb se konstante</i> | k | 9,0 x 10 ⁹ N·m ² ·C ⁻² |
| Charge on electron <i>Lading op elektron</i> | e | -1,6 x 10 ⁻¹⁹ C |
| Electron mass <i>Elektronmassa</i> | m _e | 9,11 x 10 ⁻³¹ kg |

TABLE 2: FORMULAE/TABEL 2: FORMULES**MOTION/BEWEGING**

| | |
|---|---|
| $v_f \square v_i \square a \square t$ | $\Delta x \square v_i \Delta t \square \frac{1}{2} a \square t^2$ or/of $\Delta y \square v_i \Delta t \square \frac{1}{2} a \square t^2$ |
| $v_f^2 \square v_i^2 \square 2a \square x$ or/of $v_f^2 \square v_i^2 \square 2a \square y$ | $\Delta x \square \frac{v_i \square v_f}{2} \square \Delta t$ or/of $\Delta y \square \frac{v_i \square v_f}{2} \square \Delta t$ |

FORCE/KRAG

| | |
|--|---|
| $F_{\text{net}} \square ma$ | $p \square mv$ |
| $f_s^{\text{max}} = \mu_s N$ | $f_k = \mu_k N$ |
| $F_{\text{net}} \Delta t = \Delta p$ $\Delta p = mv_f - mv_i$ | $w \square mg$ |
| $F = G \frac{m_1 m_2}{d^2}$ or/of $F = G \frac{m_1 m_2}{r^2}$ | $g \square G \frac{M}{d^2}$ or/of $g \square G \frac{M}{r^2}$ |

WORK, ENERGY AND POWER/ARBEID, ENERGIE EN DRYWING

| | |
|---|--|
| $W = F \Delta x \cos \square$ | $U \square mgh$ or/of $E_p \square mgh$ |
| $K \square \frac{1}{2} mv^2$ or/of $E_k \square \frac{1}{2} mv^2$ | $W_{\text{net}} \square \square K$ or/of $W_{\text{net}} \square \square E_k$ $\square K \square K_f \square K_i$ or/of $\square E_k \square E_{kf} \square E_{ki}$ |
| $W_{\text{nc}} \square \square K \square \square U$ or/of $W_{\text{nc}} \square \square E_k \square \square E_p$ | $P \square \frac{W}{\square t}$ |
| $P_{\text{ave}} = Fv_{\text{ave}}$ / $P_{\text{gemid}} = Fv_{\text{gemid}}$ | |

WAVES, SOUND AND LIGHT/GOLWE, KLANK EN LIG

| | |
|---|---|
| $v \square f \square \square$ | $T \square \frac{1}{f}$ |
| $f_L \square \frac{v \square v_L}{v \square v_s} f_s$ or/of $f_L \square \frac{v \square v_L}{v \square v_b} f_b$ | $E \square hf$ or/of $E \square \frac{hc}{\square}$ |
| $E = W_0 + E_{k(\text{max})}$ or/of $E = W_0 + K_{\text{max}}$ where $E \square hf$ and $W_0 \square hf_0$ and $E_{k(\text{max})} \square \frac{1}{2} mv_{\text{max}}^2$ or $K_{\text{max}} \square \frac{1}{2} mv_{\text{max}}^2$ | |
| $E = W_0 + E_{k(\text{maks})}$ of $E = W_0 + K_{\text{maks}}$ waar $E \square hf$ en $W_0 \square hf_0$ en $E_{k(\text{maks})} = \frac{1}{2} mv_{\text{maks}}^2$ of $K_{\text{maks}} = \frac{1}{2} mv_{\text{maks}}^2$ | |

ELECTROSTATICS/ELEKTROSTATIKA

| | |
|---|----------------------------|
| $F \propto \frac{kQ_1Q_2}{r^2}$ | $E \propto \frac{kQ}{r^2}$ |
| $V \propto \frac{W}{q}$ | $E \propto \frac{F}{q}$ |
| $n = \frac{Q}{e}$ or/of $n = \frac{Q}{q_e}$ | |

ELECTRIC CIRCUITS/ELEKTRIESE STROOMBANE

| | |
|--|---|
| $R \propto \frac{V}{I}$ | emf (ϵ) = I(R + r) emk (ϵ) = I(R + r) |
| $R_s \propto R_1 \propto R_2 \propto \dots$ $\frac{1}{R_p} \propto \frac{1}{R_1} \propto \frac{1}{R_2} \propto \dots$ | $q \propto I \cdot t$ |
| $W = Vq$ $W = VI \cdot t$ $W = I^2R \cdot t$ $W = \frac{V^2 \Delta t}{R}$ | $P \propto \frac{W}{\Delta t}$ $P = VI$ $P = I^2R$ $P \propto \frac{V^2}{R}$ |

ALTERNATING CURRENT/WISSELSTROOM

| | |
|--|---|
| $I_{rms} \propto \frac{I_{max}}{\sqrt{2}}$ / $I_{wgk} \propto \frac{I_{maks}}{\sqrt{2}}$ | $P_{ave} \propto V_{rms} I_{rms}$ / $P_{gemiddeld} \propto V_{wgk} I_{wgk}$ |
| $V_{rms} \propto \frac{V_{max}}{\sqrt{2}}$ / $V_{wgk} \propto \frac{V_{maks}}{\sqrt{2}}$ | $P_{ave} \propto I_{rms}^2 R$ / $P_{gemiddeld} \propto I_{wgk}^2 R$ |
| | $P_{ave} \propto \frac{V_{rms}^2}{R}$ / $P_{gemiddeld} \propto \frac{V_{wgk}^2}{R}$ |