

PLAN VIEW

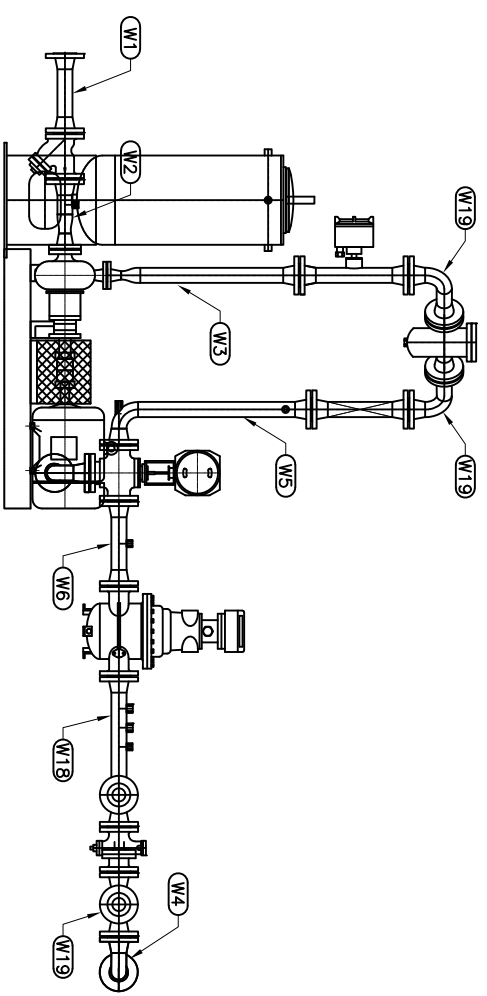

ELEVATION

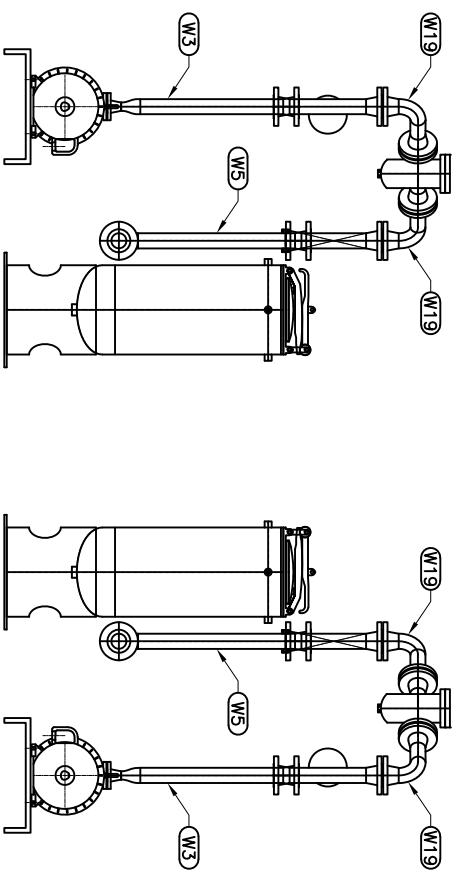

END VIEW

NO.	GENERAL NOTES	REFERENCE NUMBER	REFERENCE DRAWING	REV.	DATE	REVISION	DRAWN	CHK'D	APPR.
1.	ALL DIMENSIONS IN INCHES			A					
2.	MATERIAL = VARIES			B					
3.	GENERAL TOLERANCES = ±1/8"			C					
4.				D					
5.				E					
6.				F					
7.				G					

 <p>3421 N. SYLVANIA AVE FORT WORTH, TX 76111 FAX (817) 744-8242 WWW.UMC-PPA.COM</p>	<p>CLIENT:</p> <p>RESOURCES</p> <p>SCALE: N.T.S.</p> <p>CHECKED: -</p>	<p>TITLE:</p> <p>2" - 150# ANSI LACT UNIT PROCESS PIPING ASSEMBLY & DETAILS</p> <p>SHEET -</p> <p>UMC-50195-PPA</p>
--	--	---