

PLAN VIEW

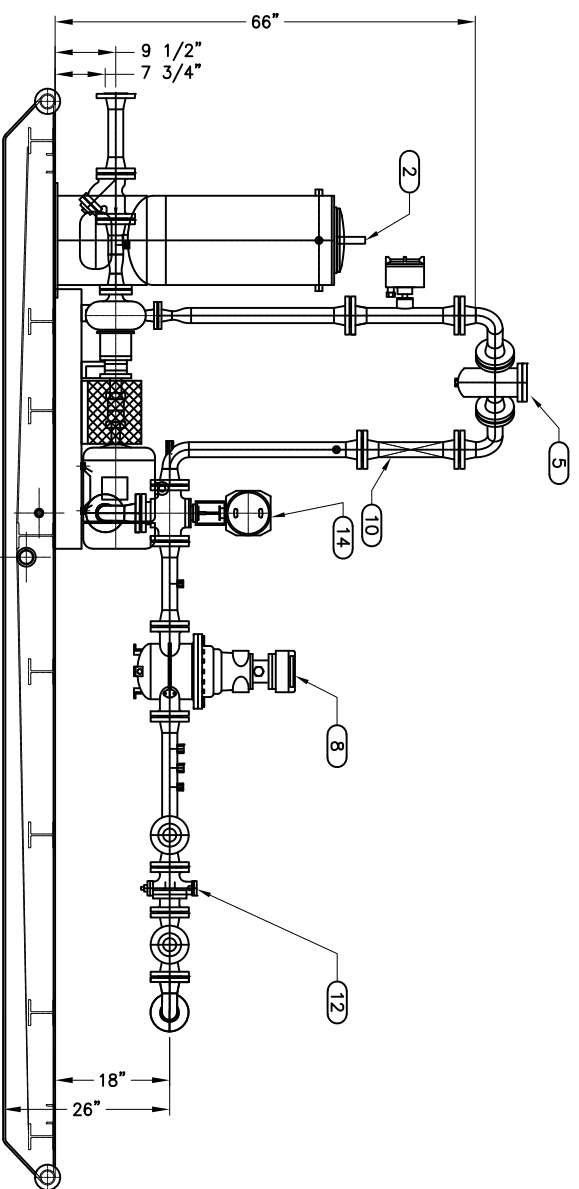

ELEVATION

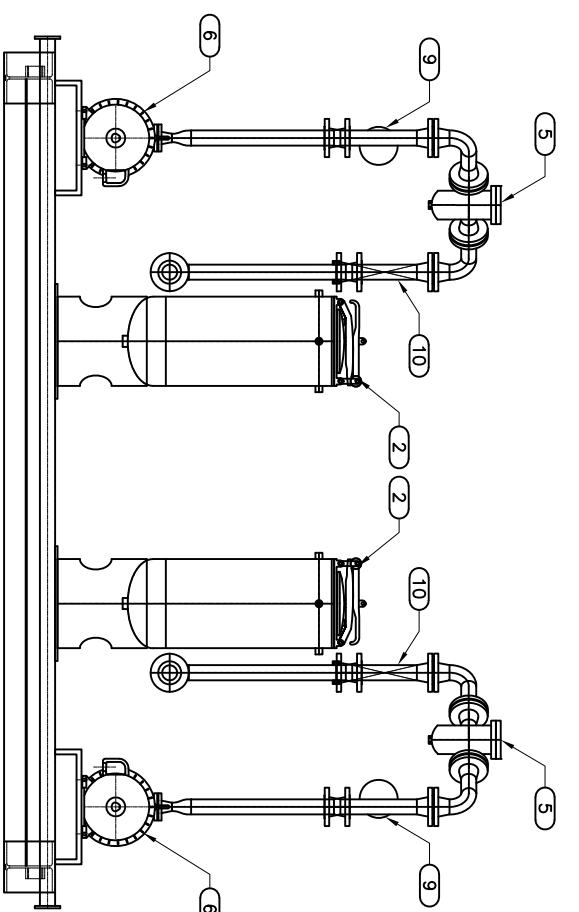

SECTION B-B

MAJOR EQUIPMENT LISTING		WEIGHT EACH	TOTAL WEIGHT
ITEM QTY.	DESCRIPTION		
1	STRUCTURAL SKID ASSY	3307.00lb	3307 lb
2	SAMPLE RECEIVER 15 GAL (SAMPLE POT) ASSY	201.00lb	402 lb
3	SAMPLE CIRCULATION PUMP & MOTOR ASSY	*80.00lb	160 lb
4	PROVER BOX ASSY (NOT SHOWN)	*100.00lb	200 lb
5	LACT STRAINER UMC 2"x6"-150# FLANGED	*85.00	170 lb
6	LACT PUMP 1 1/2"x1" FLANGED	*460.00lb	920 lb
7	AIR ELIMINATOR ASSY	2.00lb	4 lb
8	METER FMC/SMITH G2-S3 2"-150# W/RT. ANGLE DRIVE & COUNTER WPULSER	130.00lb	260 lb
9	PROBE BS&W 2"-150# FLANGED	*20.00lb	40 lb
10	STATIC MIXER UMC 2"-150# TWO ELEMENT W/ FLOW STRAIGHTENING VANE	*16.00lb	32 lb
11	VALVE BP 2" 150# FLANGED	*40.00lb	160 lb
12	VALVE 2" DB&B 150# FLANGED	*47.50lb	96 lb
13	VALVE BALL 2" 150# FLANGED	*47.50lb	192 lb
14	VALVE DIVERT 2" 3-WAY 150# FLANGED W/ACTUATOR	*70.00lb	140 lb
15	VALVE CHECK 2" 150# FLANGED	*35.00lb	70 lb
16	STRAINER Y 2" 150# FLANGED	*30.00lb	60 lb
17	PROCESS PIPE ASSY 3" 150# FLANGED	*358.00lb	716 lb
18	STRAINER/AIR ELIMINATOR PROCESS PIPE ASSY (NOT SHOWN)	*20.00lb	40 lb
18	FIBERGLASS BUILDING (NOT SHOWN)	*2500.00lb	2500 lb
18		TOTAL ESTIMATED WEIGHT	9469 lb

NO.	GENERAL NOTES	REFERENCE NUMBER	REFERENCE DRAWING	REV.	DATE	REVISION	DRAWN	CHK'D	APPR.
1.	ALL DIMENSIONS IN INCHES			A					
2.	MATERIAL = ?			B					
3.	GENERAL TOLERANCES = ±			C					
4.				D					
5.				E					
6.				F					
7.				G					

3421 N. SYLVANIA AVE
FORT WORTH, TX 76111
FAX (817) 744-8242
WWW.UMC-ENERGY.COM

CLIENT: _____

SCALE: N.T.S. _____

CHECKED: _____

DATE: 7/24/13

DRAWN: DOF _____

DATE: _____

SHEET _____

RESOURCES

2" - 150# ANSI LACT UNIT

GENERAL ASSEMBLY

UMC-50196-GA