

Flow Transmitter for Liquids / Gases (W2, W2-1, W3 & W3-1 Options)

An integrated construction using a wet/wet DP sensor protected by a stainless-steel diaphragm which provide a 4-20mA output signal.

Features and Benefits

- 3.5" (90mm) 270° analog dial for reading at a glance
- 2-Wire loop Powered 4-20mA (linear or non-linear) Output Signals
- Measures 6:1 range with $\pm 3\%$ F.S. accuracy
- Liquid flow ranges from 4 GPH (15 l/h) in 1/2" flow meter to 3000 GPM (12000 l/m) in 8" flow meter.
- Gas flow ranges from 40 SCFH (1 Nm³/h) in 1/2" flow meter to 20,000 SCFM (600Nm³/m) in 8" flow meter.

Applications

- Compressed Gas Monitoring
- Chillers and Process Cooling Systems
- Pre-Conditioned Air Handlers (Airport Jetways)



Principle of Operation

Our differential pressure flow meters are based on the premise that the pressure drop across the meter is proportional to the square of the flow rate. The flow rate is obtained by measuring the pressure differential and extracting the square root. A pair of metal bellows and piezoresistive wet/wet differential pressure sensor (linear or non-linear 4-20mA output signal) is used to sense the differential pressure across a calculated flow nozzle.

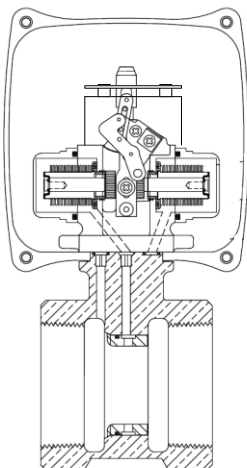

Specifications

	Standard	Options
Housing (W2 / W2-1)	Polycarbonate	Aluminum
Housing (W3 / W3-1)	Aluminum	n/a
Body	Bronze 316 SS	
Bellows	Bronze 316 SS	Inconel
DP Sensor	316 SS	n/a
Seals	Buna-N	Viton
Crystal	Polycarbonate	Glass Plastic
Gear Movement	Bronze	316 SS
Pressure		
Maximum	180 psig	400 psig
Minimum	10 psig	10 psig
Temperature		
Maximum	212°F	350°F
Minimum	-30°F	-80°F

Transmitter

Accuracy	$\pm 3\%$ F.S. Above 15% F.S.
Repeatability	$\pm 1\%$ F.S.
Ambient Temp.	120°F, 50°C
Current Output	2-wire loop powered 4-20mA DC
Response Time	(10% ~ 90%) : ≤ 1 ms
Static Pressure	20MPa max.
Position Effect	Deviate 90° from any orientation, zero change $\leq 0.2\%$ F.S.
Power Supply	2-wire 15 ~ 28 VDC (not included option PS-24)

Model Number System

The example **1/2"-71-R-10-ADW2** describes a 1/2" pipe size, 7000 series threaded connection, bronze material, flow from left to right, flow rate of 10 GPM, Options - Viton seals (A), Gasket case (D) and 4-20mA output signal (W2).

<u>1/2"</u>	-	<u>7</u>		<u>1</u>	-	<u>R</u>	-	<u>10</u>	-	<u>ADW2</u>
Pipe Size		Series		Material		Flow Direction		Flow Rate		Options
1/4"	(8mm)	7000 Series		1 - Bronze		L – Right to Left		See Flow Chart		See Table
1/2"	(15mm)	8000 Series		2 - Monel		R – Left to Right				
3/4"	(20mm)			3 - SST		VUR – Vertical Up Flow Dial Right				
1"	(25mm)					VUL - Vertical Up Flow Dial Left				
1 1/2"	(40mm)					VDR - Vertical Down Flow Dial Right				
2"	(50mm)					VDL - Vertical Up Flow Dial Left				
2 1/2"	(65mm)									
3"	(80mm)									
4"	(100mm)									
5"	(125mm)									
6"	(150mm)									
8"	(200mm)									

Table of Options

A	Viton Seals
C	Calibrated for Specific Gravity
D	Gasketed Case
D2	Gasketed Case w/Condulet
E	Non-Standard Flow Rate
ES	Low Flow Rate (Below 2 GPM)
F	Aluminum Housing w/Plastic Dial Crystal
F2	Aluminum Housing w/Glass Dial Crystal
G	Custom Scales and Dials
H	High Pressure Service (400 psig max.)
I	Compressed Gas Service
P	Panel Mount
R2	Remote Readout, Brass (Mech. Indicator)
R3	Remote Readout, 316 SS (Mech. Indicator)
T	Expanded Temperature (-80°F-350°F max.)
V	High Viscosity Service (5-500 cps)
W2	4-20mA dc (non-linear w/ local mechanical indicator)
W2-1	4-20mA dc (linear + Hart w/local mechanical indicator)
W3	4-20mA dc (non-linear blind transmitter)
W3-1	4-20mA dc (linear + Hart blind transmitter)

Flow Ranges – Series 7000 & 8000

	Size	Liquids				Gases				
		GPM	LPM	SCFM	Nm³/h	GPM	LPM	SCFM	Nm³/h	
	1/4	2	8	10	15	2 1/2	60	240	600	1000
	1/4	3	10	20	30	2 1/2	100	400	800	1200
	1/4	4	15	30	50	2 1/2	150	600	1000	1500
						2 1/2	200	800	1200	2000
	1/2	2	8	10	15	3	200	800	1000	1500
	1/2	3	10	20	30	3	300	1000	2000	3000
	1/2	4	15	30	50	3	400	1500	3000	5000
	1/2	6	25	40	80	3	500	2000	4000	6000
	1/2	10	40	60	100				SCFM	Nm³/m
	3/4	6	25	60	100	4	300	1000	1500	50
	3/4	10	40	100	150	4	400	1500	3000	100
	3/4	15	60	150	200	4	600	2400	5000	150
	3/4	20	80	200	300	4	800	3000	6000	200
	1	15	60	150	250	5	300	1000	1500	50
	1	20	80	200	400	5	400	1500	3000	100
	1	30	120	300	500	5	600	2400	5000	150
	1	40	150	400	600	5	800	3000	6000	200

Low Flow Rates – Option ES

Size	GPH	l/h	cc/m	1 1/2	30	120	300	500	6	600	2400	3000	100
1/2	4	15	200	1 1/2	40	150	400	600	6	800	3000	5000	150
1/2	6	20	300	1 1/2	60	240	600	1000	6	1000	4000	8000	250
1/2	10	40	400	1 1/2	100	400	800	1200	6	2000	8000	15000	400
1/2	15	60	600	2	40	150	400		8	600	2400	5000	150
1/2	20	80	1000	2	60	240	600		8	1000	4000	8000	250
1/2	30	120	2000	2	100	400	800		8	2000	8000	15000	400
1/2	40	150	3000	2	150	600	1000		8	3000	12000	20000	600
1/2	60	240	4000	2	200	800	1200						
1/2	100	400	6000										

Note: Available with 1/2" 7000 Series Only

7000 Series – 1/4" to 3" Connections

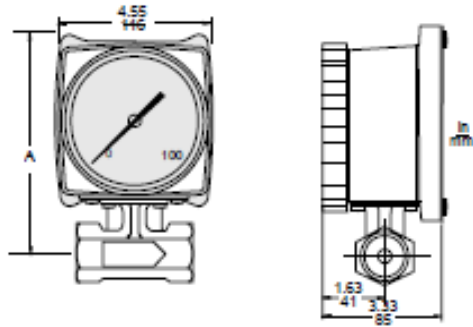

8000 Series – 1/2" to 8" Connection

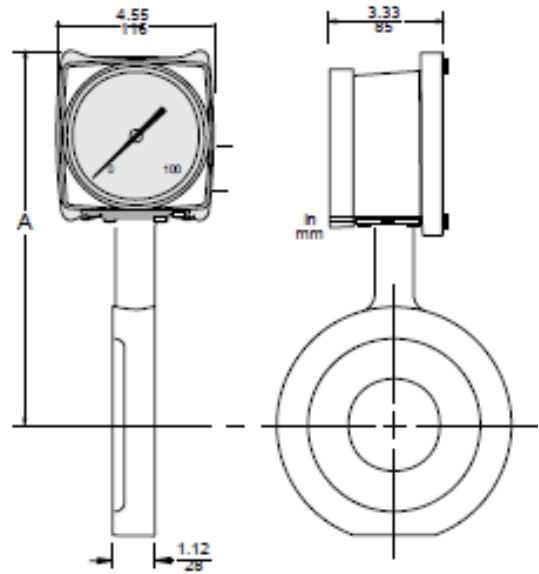

Dimensions

Nominal Sizes		Series 7000 – A		Series 8000 - A	
In	mm	In	mm	in	mm
1/4	08	5.95	151	n/a	n/a
1/2	15	5.95	151	6.62	168
3/4	20	5.95	151	7.06	179
1	25	6.07	154	7.25	184
1 1/2	40	6.39	162	7.81	198
2	50	6.80	172	8.00	203
2 1/2	65	n/a	n/a	8.54	217
3	80	7.48	190	8.87	225
4	100	n/a	n/a	9.95	252
5	125	n/a	n/a	10.36	263
6	150	n/a	n/a	11.05	280
8	200	n/a	n/a	12.30	311

Note: Dimensions are based on bronze meters.

Piping Requirements

The site selected should provide at least 10 pipe diameters of straight meter sized pipe between the meter inlet and any upstream fitting such as elbow, tee or valve.

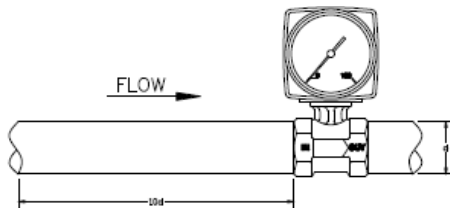

Pressure Drop Characteristics

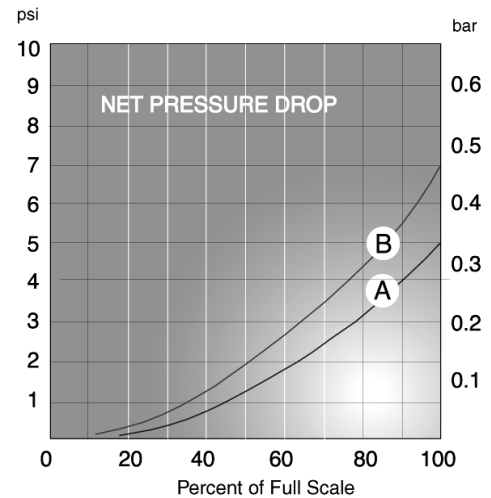

Curve A – Bronze Bellows
Curve B – Monel, SS, Inconel Bellows

RCM Industries, Inc.

110 Mason Circle Concord, CA 94520-1238 USA
Ph. 925.687.8363 Toll Free 888-flo-gage Fax 925.671.9636
e-mail : sales@flo-gage.com <http://www.flo-gage.com>