

FLO-Gard II

1000 / 2000 Series

Flow Switches for Liquids / Gases (HAZ LOC) (-1S2-IS, -2S2-IS or -1S2-IS-LED, -2S2-IS-LED Options)

Sturdy in-line metal construction (Brass or SST) are fitted with 1 (option 1S2) or 2 (option 2S2) single pole double throw reed switches for safety interlock or control circuits.

Features and Benefits

- Suitable for use with opaque and clear fluids or gases
- CSA / KEMA Approved for Hazardous Location
- Liquid flow ranges from 4 GPH (15 l/h) in 1/2" flow meter to 3000 GPM (12000 l/m) in 8" flow meter.
- Gas flow ranges from 40 SCFH (1 Nm³/h) in 1/2" flow meter to 20,000 SCFM (600Nm³/m) in 8" flow meter.

Applications

- Chillers
- Liquid Cooled UHF TV Transmitters
- Industrial Energy & Utilities



Principle of Operation

Our differential pressure flow meters are based on the premise that the pressure drop across the meter is proportional to the square of the flow rate. The flow rate is obtained by measuring the pressure differential and extracting the square root. Our single pole double throw switches can be adjusted independently from 30% to 90% of full scale.

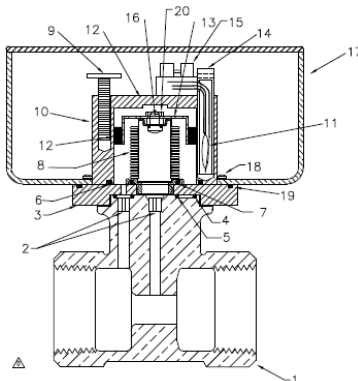

- 1 – 1000 Series Body
- 2 – Pulsation Snubbers
- 3 – Adapter Block
- 4 – O24 O-Ring
- 5 – O16 O-Ring
- 6 – O27 O-Ring
- 7 – O16 O-Ring
- 8 – Bellows (Brass or SST)
- 9 – Adjustment Screw
- 10 – Body Block
- 11 – Reed Switches
- 12 – Magnets
- 13 – Magnet Holder
- 14 – Reed Switch Housing
- 15 – Terminal Block
- 16 – 6-32 x 5/15" Seal Screw
- 17 – Aluminum Housing
- 18 – 4-40 x 1/4" Screw
- 19 – O37 O-Ring
- 20 – 6-32 Jam Nut

Specifications

	Standard	Options
Housing	Aluminum	n/a
Body	Bronze 316 SS	n/a
Bellows	Bronze 316 SS	n/a
Seals	Buna-N	Viton EPR Teflon
Pressure		
	Maximum 400 psig	n/a
	Minimum 10 psig	n/a
Temperature		
	Maximum 212°F	350°F
	Minimum -30°F	-80°F

Reed Switches (Intrinsically Safe)

Setability	± 5% F.S.
Repeatability	± 1% F.S.
Hysteresis	7 to 13% F.S.
Entity Parameters	V _{max} = 28V I _{max} = 110mA P _{max} = 1.2W C _i = 0uF L _i = -uH
LED Rating	0.50 Watts 24V, 20mA

Hazardous Location Approval

CSA / NRTL/c:

AEx ia IIC: Class I, Division I, Groups A, B, C, and D
Class II, Division I, Groups E, F, and G

KEMA: Ex ia IIC: Zone 0, II 1G T4 0° ≤ Ta ≤ 50°C
ATEX EC Type Examination

Model Number System

The example **1/2"-11-10-2S2-IS** describes a 1/2" pipe size, 1000 series threaded connection, bronze material, flow rate of 10 GPM, Options – 2 single pole double throw (2S2 option) and Intrinsic Safe Approval (-IS).

<u>1/2"</u>	-	<u>1</u>	-	<u>1</u>	-	<u>10</u>	-	<u>2S2-IS</u>
Pipe Size		Series		Material		Flow Rate		Options
1/4"	(8mm)	1000		1 - Bronze		See Flow Chart		See Table
1/2"	(15mm)	2000		2 - Monel				
3/4"	(20mm)			3 - SST				
1"	(25mm)							
1 1/2"	(40mm)							
2"	(50mm)							
2 1/2"	(65mm)							
3"	(80mm)							
4"	(100mm)							
5"	(125mm)							
6"	(150mm)							
8"	(200mm)							

Table of Options

A	Viton Seals
B	EPR Seals
B2	Teflon Seals
ES	Low Flow Rate (Below 2 GPM)
I	Compressed Gas Service
1S2	1 Single Pole Double Throw Switch
2S2	2 Single Pole Double Throw Switches
-IS	Intrinsic Safe Approval
-LED	Light Emitting Diode

Flow Ranges – Series 7000 & 8000

Size	Liquids				Gases				
	GPM	LPM	SCFM	Nm ³ /h	Size	GPM	LPM	SCFM	Nm ³ /h
1/4	2	8	10	15	2 1/2	60	240	600	1000
1/4	3	10	20	30	2 1/2	100	400	800	1200
1/4	4	15	30	50	2 1/2	150	600	1000	1500
2 1/2	200	800	1200	2000					
1/2	2	8	10	15	3	200	800	1000	1500
1/2	3	10	20	30	3	300	1000	2000	3000
1/2	4	15	30	50	3	400	1500	3000	5000
1/2	6	25	40	80	3	500	2000	4000	6000
1/2	10	40	60	100					
								SCFM	Nm³/m
3/4	6	25	60	100	4	300	1000	1500	50
3/4	10	40	100	150	4	400	1500	3000	100
3/4	15	60	150	200	4	600	2400	5000	150
3/4	20	80	200	300	4	800	3000	6000	200

Low Flow Rates – Option ES

Size	GPH	l/h	cc/m	1	15	60	150	250	5	300	1000	1500	50
1/2	4	15	200	1	20	80	200	400	5	400	1500	3000	100
1/2	6	20	300	1	30	120	300	500	5	600	2400	5000	150
1/2	10	40	400	1	40	150	400	600	5	800	3000	6000	200
1/2	15	60	600	1 1/2	30	120	300	500	6	600	2400	3000	100
1/2	20	80	1000	1 1/2	40	150	400	600	6	800	3000	5000	150
1/2	30	120	2000	1 1/2	60	240	600	1000	6	1000	4000	8000	250
1/2	40	150	3000	1 1/2	100	400	800	1200	6	2000	8000	15000	400
1/2	60	240	4000	2	40	150	400	600	8	600	2400	5000	150
1/2	100	400	6000	2	60	240	600	1000	8	1000	4000	8000	250
				2	100	400	800	1200	8	2000	8000	15000	400
				2	150	600	1000	1500	8	3000	12000	20000	600
				2	200	800	1200	2000					

Note: Available with 1/2" 7000 Series Only

7000 Series – 1/4" to 3" Connections

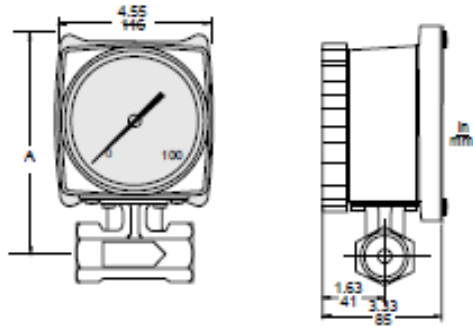

8000 Series – 1/2" to 8" Connection

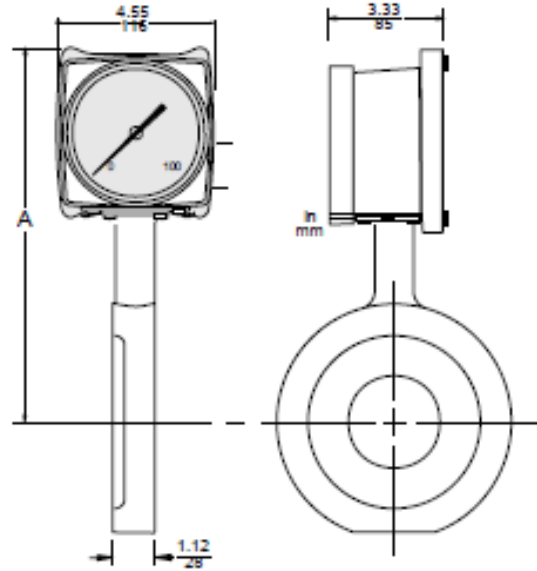

Dimensions

Nominal Sizes		Series 7000 – A		Series 8000 - A	
In	mm	In	mm	in	mm
1/4	08	5.95	151	n/a	n/a
1/2	15	5.95	151	6.62	168
3/4	20	5.95	151	7.06	179
1	25	6.07	154	7.25	184
1 1/2	40	6.39	162	7.81	198
2	50	6.80	172	8.00	203
2 1/2	65	n/a	n/a	8.54	217
3	80	7.48	190	8.87	225
4	100	n/a	n/a	9.95	252
5	125	n/a	n/a	10.36	263
6	150	n/a	n/a	11.05	280
8	200	n/a	n/a	12.30	311

Note: Dimensions are based on bronze meters.

Piping Requirements

The site selected should provide at least 10 pipe diameters of straight meter sized pipe between the meter inlet and any upstream fitting such as elbow, tee or valve.

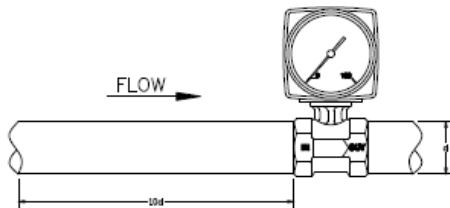

Pressure Drop Characteristics

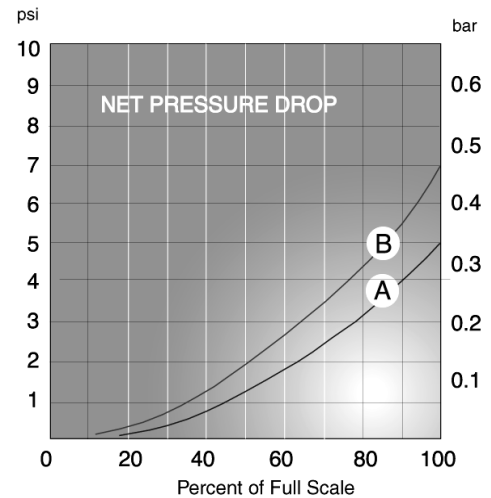

Curve A – Bronze Bellows
Curve B – Monel, SS, Inconel Bellows

RCM Industries, Inc.

110 Mason Circle Concord, CA 94520-1238 USA
Ph. 925.687.8363 Toll Free 888-flo-gage Fax 925.671.9636
e-mail : sales@flo-gage.com <http://www.flo-gage.com>